



# Avalon Bay



## Air Fryer Product Guide (AB-Airfryer230B)

## Introduction

This Air Fryer is used for cooking food, such as meat, fish, side dishes, and vegetables. This Air Fryer is not designed for commercial use or operation in a company. This Air Fryer may only be used for private purposes, as any other use is not as intended. Furthermore, the Air Fryer may not be used outdoors, or in tropical climates. This Air Fryer meets all relevant norms and standards in relation to CE conformity. In the event of any modification to the Air Fryer that was not approved by the manufacturer, compliance with these standards is no longer guaranteed. The manufacturer does not accept any liability for any resulting damage or faults in such cases.

Please observe the regulations and laws in the country of use.



**Before using your Air Fryer, please read this manual carefully. Incorrect operation can result in serious damage or injury.**

## Need to Contact Us?

<b>WEBSITE:</b>	<a href="http://www.avalon-bay.com">http://www.avalon-bay.com</a>
<b>SUPPORT EMAIL ADDRESS:</b>	<a href="mailto:support@avalon-bay.com">support@avalon-bay.com</a>
<b>TELEPHONE NUMBER:</b>	1-844-528-2566

## Thank You for Choosing the Avalon Bay Air Fryer

Please read this manual thoroughly and follow all instructions and safety guidelines. With proper care and maintenance, this appliance will provide you with many years of trouble-free use.

For future reference, we recommend you attach a copy of your sales receipt below and record the following information, located on the manufacturer's nameplate on the rear of the unit. You will need this information if it becomes necessary to contact the manufacturer for service inquiries.

**Date of Purchase:** \_\_\_\_\_

**Serial Number:** \_\_\_\_\_

**Model Number:** \_\_\_\_\_

## Contents

Introduction .....	2
Need to Contact Us? .....	2
General Description .....	4
Important Safety Precautions .....	5
Getting to Know Your Avalon Bay Air Fryer .....	7
Prior to Use .....	7
First Use .....	7
Using the Appliance .....	7
Settings .....	10
Automatic Programming.....	10
Cooking Tips.....	10
Caring For Your Air Fryer.....	13
Maintenance.....	13
Cleaning .....	13
Storage.....	14
Environmental and Disposal Information .....	14
Troubleshooting.....	15
Limited Manufacturer’s Warranty .....	17
Warranty Terms .....	17

## Product Specifications

<b>MODEL:</b>	AB-Airfryer230B
<b>POWER SUPPLY:</b>	120v ~60hZ
<b>POWER CONSUMPTION:</b>	1400W
<b>TEMPERATURE RANGE:</b>	160° to 400° F (+/- 15°F)
<b>TIMER FUNCTION:</b>	Up to 60 minutes
<b>BASKET VOLUME:</b>	Up to 3.7 quarts
<b>cETL Certified:</b>	Yes
<b>Non-Stick:</b>	Yes
<b>Dishwasher-Safe:</b>	Yes

## General Description

### Supplied Items

- AB-Airfryer230B
- These operating instructions, which have a fold-out cover. The Air Fryer is illustrated with numbers below. The numbers indicate the following:

1. Carrying handle
2. Display (including touch operation)
3. Basket
4. Pan
5. Release button (including cover)
6. Handle
7. Ventilation slots (bottom)
8. Ventilation slots (rear)

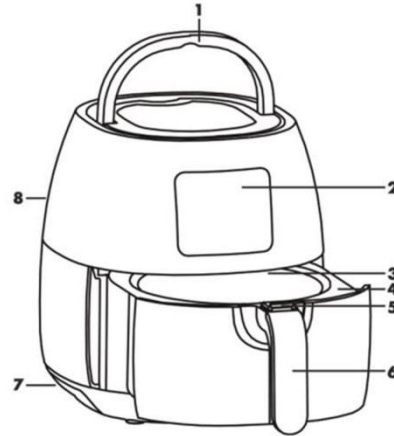

### Display

9. Temperature
10. Automatic programs
11. "Increase temperature"
12. "Reduce temperature"
13. "On/standby"
14. Fan
15. Heating
16. "Start/pause"
17. Timer
18. "Program selection"
19. "Reduce minutes"
20. "Increase minutes"

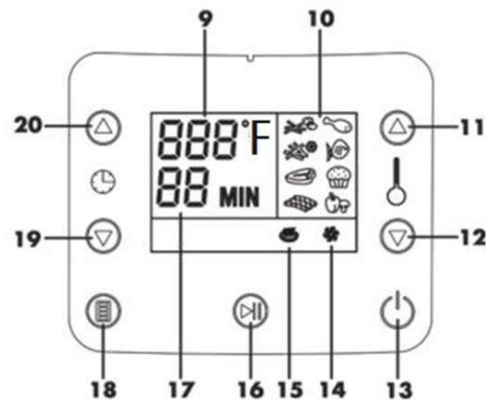

## Important Safety Precautions

Before using the Air Fryer for the first time, read the following instructions and pay attention to all warnings, even if you are familiar with handling electronic devices. Store these operating instructions in a safe place for future reference. If you sell the Air Fryer, or pass it on, always include these instructions. They are an integral part of the product.

### Symbols Used and Their Meaning



**WARNING!** This symbol indicates important information for safe operation of the Air Fryer and the safety of the user.



**DANGER!** This symbol warns about injuries or burns associated with hot surfaces of the Air Fryer.



This symbol indicates other important information on the topic.

### Warning

- The Air Fryer is not intended to be operated with an external time switch, or a separate remote control system. Never leave the Air Fryer unattended when it is switched on. It poses a fire hazard!
- This Air Fryer can be used by children ages eight and older, and by persons with reduced physical, sensory or mental abilities, or lack of experience and knowledge, if they are supervised or have been instructed on the safe use of the device and understand the resulting risks. Children must not play with the Air Fryer. Cleaning and user maintenance must not be carried out by children without supervision. Always keep plastic packaging away from children. It poses a suffocation risk.
- If smoke is produced, or there are any unusual sounds or smells, switch off the Air Fryer immediately and remove the main plug from the socket. In these cases, the Air Fryer should not be used until it has been inspected by authorized service personnel. Never inhale smoke from a potential device fire. If you have inhaled smoke, consult a doctor. The inhalation of smoke can be harmful.
- Never touch the main cable and the Air Fryer with wet hands because there is a risk of an electric shock!
- The Air Fryer must not be covered, to avoid overheating. Covering it poses a fire hazard!
- Always place the Air Fryer on a flat, heat-resistant surface and not in the vicinity of heat sources and flammable materials, liquids, or gases. Leave at least 19.7 inches clearance all around the

Air Fryer to prevent contact with flammable and combustible materials, because there is a risk of fire!

- The Air Fryer must not be damaged, in order to prevent hazards.
- Ensure that no fire sources (i.e., burning candles) are placed on or near the Air Fryer. It poses a fire hazard!
- Do not leave the Air Fryer unattended when it is operating. Always switch off the Air Fryer when it is not in use and remove the main plug from the socket. Put away the Air Fryer only when it has completely cooled down. It poses a fire hazard!
- Remove the main plug from the socket to disconnect the Air Fryer completely from the power supply.
- The Air Fryer must never be exposed to any direct heat sources (i.e., heaters), or direct sunlight, or bright artificial light. Also, avoid contact with dripping water and splashes and corrosive liquids. Do not use their Air Fryer near water. In particular, the Air Fryer should never be submerged in liquid. Do not place any items filled with liquid (i.e., vases or drinks) on the Air Fryer. Also, ensure that the Air Fryer is never subjected to excessive shocks and vibrations. Furthermore, no foreign objects may penetrate the device, otherwise the Air Fryer could be damaged.



**CAUTION: FIRE HAZARD! Never use the Air Fryer in the vicinity of flammable materials, such as curtains, drapes, etc.**

## Main Cable

---

- Always handle the main cable by the main plug and do not pull on the cable itself.
- Do not place the Air Fryer, furniture, or any other heavy objects on the main cable and ensure that it is not kinked.
- Never tie a knot in the main cable and do not tie cables together. Ensure that the main cable is placed so that no one can tip over it and it does not cause an obstruction.
- Make sure that the main cable does not touch any hot surfaces of the Air Fryer.
- Do not use adapter plugs or extension cables that do not comply with applicable safety standards, and do not make any alterations to the main cable! If the main cable is damaged, it must be replaced by the manufacturer, or its customer service representative, or a similarly qualified person to prevent any safety hazards.

## Getting to Know Your Avalon Bay Air Fryer

### Prior to Use

Take the Air Fryer out of the packaging and remove the packaging material completely. Check the Air Fryer for signs of damage. The Air Fryer must not be used if it is damaged. Prior to its initial use, clean the Air Fryer, as described in the section “CLEANING.”

### First Use



**Place the Air Fryer on a flat, heat-resistant surface. If the surface is sensitive, place a heat-resistant board under the Air Fryer.**



**There is a risk of burns! The temperature of the accessible surfaces may be very high when the device is operating. Hot steam continues to escape from the ventilation slots during operation. Hot steam may also escape when you open the air fryer. To remove the food, just touch the handle and do not touch the pan, basket, or the inside of the Air Fryer.**



**The accessible surfaces of the Air Fryer can become very hot. Use potholders or oven gloves to prevent burns. There is a risk of injury.**



**The food to be fried may be placed only in the basket. The basket may be filled up the “MAX” marking at most.**



**CAUTION: FIRE HAZARD! The pan and the basket must never be filled with oil.**

### Using the Appliance

To cook food in the Air Fryer, proceed as follows:

- Remove the pan and the basket by lifting them from the Air Fryer by the handle.
- Place the food in the basket.
- Insert the pan and basket into the Air Fryer.
- Insert the main plug into a socket that is always easily accessible. A beep sounds twice.
- Press “OVEN/STANDBY” to switch on the Air Fryer. Each touch operation is confirmed by a beep.

- The temperature is at 360°F. Set the desired temperature in steps of 5°F by pressing “INCREASE TEMPERATURE”, or “REDUCE TEMPERATURE”. To start the progress of numbers, you can keep the button “INCREASE TEMPERATURE”, “REDUCED TEMPERATURE” pressed.
- The timer is set for fifteen minutes. Set the desired time by pressing “REDUCE MINUTES” or “INCREASE MINUTES”. To start the quick progress of numbers, you can keep the button “REDUCE MINUTES” or “INCREASE MINUTES” pressed.
- Press “START/PAUSE” to start the heating process. The timer indicates the remaining minutes. The symbols fan and heating are displayed in animated form in operating mode. If the set temperature has been reached, the heating symbol lights up continuously. You can pause the heating process by pressing “START/PAUSE” and restart it by pressing the button again.
- The Air Fryer switches off automatically upon expiry of the time indicated by the timer and a beep sounds several times.
- Remove your food by lifting up the pan by the handle.



**There is a risk of burns! Do not touch the pan, basket, or the inside of the Air Fryer directly.**

- Place the pan on a flat, heat-resistant surface.
- Slide the cover to one side, and then press the “RELEASE” button to detach the basket from the pan. Now place the food in a bowl or on a plate.
- The Air Fryer switches automatically to standby mode after a short time. You can also set the Air Fryer to standby mode by pressing “ON/STANDBY”.
- Clean the Air Fryer as described in section “CLEANING”.



Some food should be shaken halfway through the cooking time to ensure that it is cooked evenly. To do so, lift the pan and basket by the handle from the Air Fryer and shake the food. Re-insert the pan and basket into the Air Fryer. The Air Fryer switches itself off automatically when you remove the pan and basket. Once the pan and basket are correctly re-inserted, the Air Fryer switches itself on again automatically until the timer expires.



If you are cooking food that should be shaken halfway through the cooking time, you can also set the timer to half the cooking time. Thus, a beep sounds when you need to shake the food. After shaking the food, set the timer to the remaining cooking time to complete the full cooking time.



You can also preheat the Air Fryer without food. If the food is not fully cooked after the specified cooking time, re-insert the pan and basket correctly into the Air Fryer. Set the timer to a few extra minutes.



Place the food in a bowl, or on a plate, if you have already detached the pan from the basket. Otherwise, the excess oil that has collected in the pan will be poured over the



food.











You can also keep your ingredients warm by setting a low temperature (i.e., 180°F).

## Settings

### Automatic Programming

You can also use the Air Fryer with an automatic program. The temperature and the timer are already pre-programmed in the automatic programs. Proceed as follows to start an automatic program:

- Press “ON/STANDBY” to switch on the Air Fryer.
- By repeatedly pressing “PROGRAM SELECTION”, you can go from one automatic program to another. The following automatic program can be selected:

		Quantity	Cooking time	Temperature
	Homemade chips*	10.6-24.5	18 minutes	360 °F
	Chicken leg*	3.5-18.5	20 minutes	360 °F
	Frozen chips	10.6-18.5	16 minutes	400 °F
	Fish (fish fingers)	3.5-14	12 minutes	400 °F
	Steak / chop*	3.5-18.5	15 minutes	360 °F
	Muffins	10.5	20 minutes	400 °F
	Sausages*	3.5-18.5	10 minutes	400 °F
	Peppers / mushrooms*	3.5-14	15 minutes	400 °F

\*fresh

- Press “START/PAUSE” to start the heating process with the selected automatic program. The timer indicates the remaining minutes. The symbols fan and heating are displayed in animated form in operating mode. You can pause the heating process by pressing “START/PAUSE” and restart it by pressing the button again.
- The Air Fryer switches off automatically upon completion of the automatic program and a beep sounds.

### Cooking Tips

- Do not overfill the basket with food, for better cooking results. The basket may be filled up to the “MAX” marking at most.
- To avoid an excessively long cooking time, your food should not be too thick.

	Min-Max Amount (ounces)	Time (min)	Temp (°F)	Shake	Extra Information
<b>Potatoes &amp; Fries</b>					
Thin frozen fries	10.5-24.5	12-16	400	Shake	
Thick frozen fries	10.5-24.5	12-20	400	Shake	
Home-made fries (.3"x.3")	10.5-28	18-25	360	Shake	Add ½ tbsp. of oil
Home-made potato wedges	10.5-28	18-22	360	Shake	Add ½ tbsp. of oil
Home-made potato cubes	10.5-26.5	12-18	360	Shake	Add ½ tbsp. of oil
Rosti	9	15-18	360		
Potato gratin	18	18-22	360		
<b>Meat &amp; Poultry</b>					
Steak	3.5-18	8-22	360		
Pork chops	3.5-18	10-14	360		
Hamburger	3.5-18	7-14	360		
Sausage roll	3.5-18	13-15	360		
Drumsticks	3.5-18	18-22	360		
Chicken breast	3.5-18	10-15	360		
<b>Snacks</b>					
Spring rolls	3.5-14	8-10	400	Shake	Use oven-ready
Frozen chicken nuggets	3.5-14	6-10	400	Shake	Use oven-ready
Frozen fish fingers	3.5-14	6-10	400		Use oven-ready
Frozen bread crumbled cheese snacks	3.5-14	10	360		Use oven-ready
Stuffed vegetables	3.5-14	10	320		
<b>Baking</b>					
Cake	10.5	20-25	360		Use baking tray
Quiche	14	20-22	360		Use baking tray/oven dish
Muffins	10.5	15-18	360		Use baking tray
Sweet snacks	14	20	360		Use baking tray/oven dish

The specified times are only guide values. They may be longer or shorter, depending on the nature of the ingredients and your personal preferences.

- We recommend that you cook fourteen ounces of chips for approximately sixteen to eighteen minutes without preheating until the desired browning level has been reached to ensure that they are cooked evenly. You should shake the chips after 2/3 of the cooking time. When shaking, make sure that the chips are well mixed and thus cooked evenly. To do so, lift the pan and basket by the handle from the Air Fryer and shake the food. The Air Fryer switches itself off

automatically when you remove the pan and basket. Once the pan and basket are correctly re-inserted, the Air Fryer switches itself on again automatically until the timer expires.

- This food should be shaken halfway through the cooking time to ensure that it is cooked evenly. To do so, lift the pan and basket by the handle from the Air Fryer and shake the food. The Air Fryer switches itself off automatically when you remove the pan and basket. Once the pan and basket are correctly re-inserted, the Air Fryer switches itself on again automatically until the timer expires.
- These ingredients should be mixed with a tablespoon of oil when preparing the food in a bowl. Never pour the oil directly into the pan or basket.
- Never place dough directly in the pan or basket! Place the dough only in a suitable, heat-resistant container or baking tin (i.e., muffin tin). Place the container or baking tin in the basket.



The cooking time is extended by approximately two to three minutes if the Air Fryer has not been preheated.

## Caring for Your Air Fryer

### Maintenance

Servicing is necessary if the Air Fryer has been damaged, or if liquids or objects have penetrated the housing, if the Air Fryer has been exposed to rain or moisture, or if it does not work correctly, or has been dropped. If smoke is produced, or there are any unusual sounds or smells, switch off the Air Fryer immediately and remove the main plug from the socket. In these cases, the Air Fryer should not be used until it has been inspected by authorized service personnel. Only have qualified personnel carry out the servicing on the device. Never open the housing of the Air Fryer.

### Cleaning



**Remove the main plug from the socket before cleaning, as there is a risk of an electric shock.**



**Wait until the Air Fryer has cooled down completely. Otherwise, there is a risk of burns.**



**The Air Fryer itself must not be immersed in water, as there is a risk of an electric shock.**

- The pan and the basket can be removed for cleaning. To do so, lift the pan and basket by the handle from the Air Fryer. Slide the cover to one side, then press the “RELEASE” button to detach the basket from the pan. First, remove large remaining food particles. The pan and basket can then be cleaned in a basin of warm water and liquid soap. Rinse the pan and basket with clear water afterwards and dry them completely before inserting them again. Never use a wire brush, or other abrasive objects.
- The pan and basket are dishwasher-safe. Use a slightly damp cloth with some liquid soap, if necessary, to clean the inner and outer surfaces, and never use any solvent or cleaner that would corrode the plastic materials.
- Insert the pan and basket again after cleaning. Proceed as follows:
  - Re-insert the basket into the pan until it snaps into place.
  - Insert the pan and basket into the Air Fryer until they snap into place.

## Storage

---

If you do not want to use the Air Fryer, remove the main plug from the socket. You can store the main cable in the cable storage compartment by simply sliding it into the compartment. Ensure that the Air Fryer is kept in a clean, dry location without direct sunlight.

## Environmental and Disposal Information

---



When this symbol appears on a product, this indicates that the product is subject to the European Directive 2012/19/EU. All electrical and electronic devices must be disposed of separately from household waste at designated disposal points. Disposal of old devices in this manner will prevent harm to the environment and human health hazards. For further information regarding disposal of old devices in accordance with the directive, contact your local authorities, waste disposal office, or the shop where you bought the device.

Dispose of the packaging in an environmentally compatible manner. Cardboard can be put out for municipal paper collections, or brought to public collection points for recycling. Films and plastic used for packaging the device are collected by your local disposal services and disposed of in an environmentally compatible manner.

## Troubleshooting

### My Air fryer doesn't turn on

Problem	Possible cause	Solution
<b>Fryer does not work</b>	<ul style="list-style-type: none"> <li>You did not plug in the appliance.</li> <li>You did not set the timer.</li> </ul>	<ul style="list-style-type: none"> <li>Put the cord into a standard electrical outlet.</li> <li>Set the timer to the required time and press "Start/pause".</li> </ul>

### The pan doesn't slide into my Air fryer

Problem	Possible cause	Solution
<b>Pan does not slide into the appliance properly</b>	<ul style="list-style-type: none"> <li>You put too much food in the basket.</li> <li>You did not place the basket in the pan correctly.</li> </ul>	<ul style="list-style-type: none"> <li>Do not fill the basket beyond the MAX indicator.</li> <li>Push the basket down into the pan until it clicks.</li> </ul>

### White smoke is coming out of my Air Fryer

Problem	Possible cause	Solution
<b>White smoke comes out of the appliance</b>	<ul style="list-style-type: none"> <li>You are preparing greasy food.</li> <li>The pan still contains grease residue from a previous use.</li> </ul>	<ul style="list-style-type: none"> <li>When frying greasy food, a large amount of oil will leak into the pan. The oil produces white smoke &amp; the pan may heat up more than usual. This will not affect the appliance or the end result.</li> <li>White smoke is caused by grease heating up in the pan. Make sure you clean the pan properly after each use.</li> </ul>

### My food isn't cooking correctly

Problem	Possible cause	Solution
<b>Food is undercooked</b>	<ul style="list-style-type: none"> <li>You put too much food in the basket.</li> <li>You set the Air Fryer temperature too low.</li> </ul>	<ul style="list-style-type: none"> <li>Put smaller batches of food in the basket. Smaller batches are fried more evenly.</li> <li>Set the temperature control to the required temperature setting.</li> </ul>

Problem	Possible cause	Solution
<b>Food is fried unevenly</b>	<ul style="list-style-type: none"><li>• Certain types of food require shaking halfway through the preparation time.</li></ul>	<ul style="list-style-type: none"><li>• Food that lies on top of or across each other (e.g., fries) need to be shaken halfway through the preparation time. See <i>Settings</i> for preparation information.</li></ul>
<b>Fried snacks are not crispy</b>	<ul style="list-style-type: none"><li>• You used a type of snack meant to be prepared in a traditional deep fryer.</li></ul>	<ul style="list-style-type: none"><li>• Use oven snacks or lightly brush some oil onto the snacks for a crispier result.</li></ul>
<b>Fresh fries are fried unevenly</b>	<ul style="list-style-type: none"><li>• You did not use the right potato type.</li><li>• You did not rinse the potato sticks properly before you fried them</li></ul>	<ul style="list-style-type: none"><li>• Use fresh potatoes and make sure that they stay firm during frying</li><li>• Rinse the potato sticks again to remove starch from the outside of the sticks.</li></ul>
<b>Fresh fries are not crispy</b>	<ul style="list-style-type: none"><li>• The crispiness of the fries depends on the amount of oil and water in the fries.</li></ul>	<ul style="list-style-type: none"><li>• Make sure you dry the potato sticks properly before you add the oil. Cut the potato sticks smaller. Add slightly more oil.</li></ul>



## Limited Manufacturer's Warranty

This appliance is covered by a limited manufacturer's warranty. For one year from the original date of purchase, the manufacturer will repair or replace any parts of this appliance that prove to be defective in materials and workmanship, provided the appliance has been used under normal operating conditions as intended by the manufacturer.

### Warranty Terms

During the first year, any components of this appliance found to be defective due to materials or workmanship will be repaired or replaced at the manufacturer's discretion, and at no charge to the original purchaser. The purchaser will be responsible for any removal or transportation costs.

### Exclusions

The warranty will **not** apply if damage is caused by any of the following:

- Power failure
- Damage in transit or when moving the appliance
- Improper power supply, such as low voltage, defective household wiring, or inadequate fuses
- Accident, alteration, misuse, or abuse of the appliance, such as using non-approved accessories, inadequate air circulation in the room or abnormal operating conditions (extreme temperatures)
- Use in commercial or industrial applications
- Fire, water, damage, theft, war, riot, hostility, or acts of God, such as hurricanes, floods, etc.
- Use of force or damage caused by external influences
- Partially or completely dismantled appliances

### Obtaining Service

When making a warranty claim, please have the original bill of purchase with purchase date available. Once confirmed that your appliance is eligible for warranty service, all repairs will be performed by an Avalon Bay authorized repair facility. The purchaser will be responsible for any removal or transportation costs. Replacement parts and/or units will be new, re-manufactured, or refurbished and are subject to the manufacturer's discretion. Do not use an unauthorized person to replace or fix a damaged main cord.

For technical support and warranty service, please email [support@avalon-bay.com](mailto:support@avalon-bay.com).

## Free Manuals Download Website

<http://myh66.com>

<http://usermanuals.us>

<http://www.somanuals.com>

<http://www.4manuals.cc>

<http://www.manual-lib.com>

<http://www.404manual.com>

<http://www.luxmanual.com>

<http://aubethermostatmanual.com>

Golf course search by state

<http://golfingnear.com>

Email search by domain

<http://emailbydomain.com>

Auto manuals search

<http://auto.somanuals.com>

TV manuals search

<http://tv.somanuals.com>