

HITACHI

DIGITAL CAMERA

S-3000W / S-3000

OPERATING INSTRUCTIONS

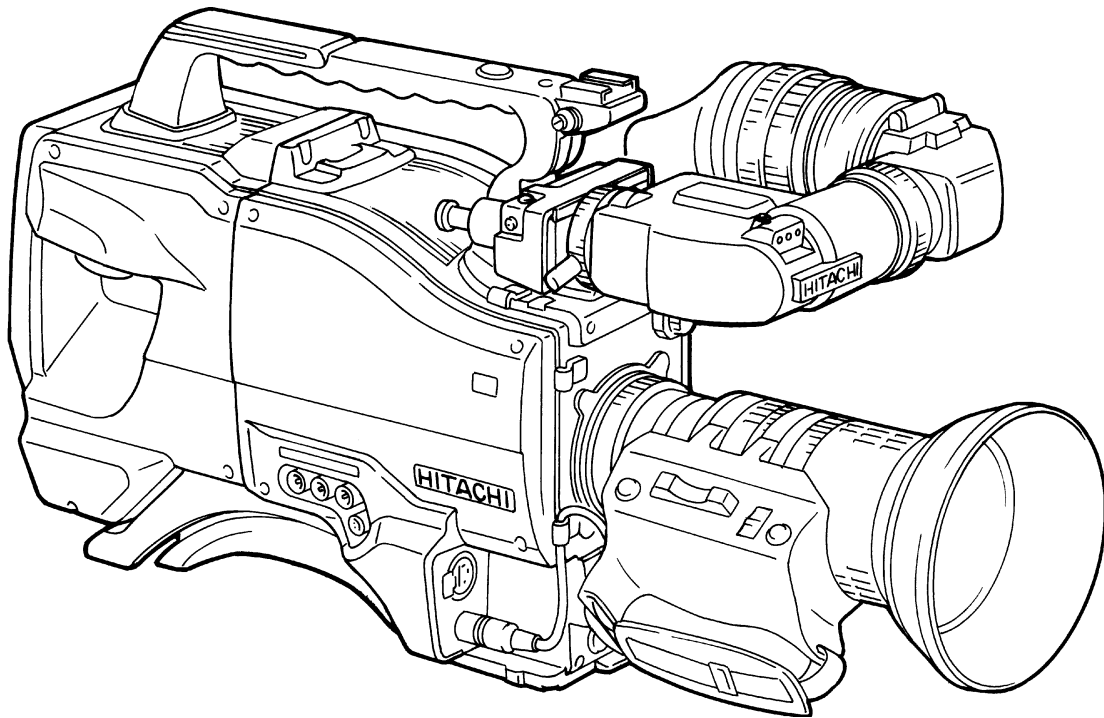

Please read this operating instructions carefully for proper operation, and keep it for future reference.

Hitachi Denshi, Ltd.

IMPORTANT SAFETY INSTRUCTIONS

1. Read Instructions

All the safety and operating instructions should be read before the product is operated.

2. Retain Instructions

The safety and operating instructions should be retained for future reference.

3. Heed Warnings

All warnings on the product and the operating instructions should be adhered to.

4. Follow Instructions

All operating and use instructions should be followed.

5. Cleaning

Unplug this product from the wall outlet before cleaning. Do not use liquid cleaners or aerosol cleaners. Use a damp cloth for cleaning.

6. Attachments

Do not use attachments not recommended by the product manufacturer as they may cause hazards.

7. Water and Moisture

Do not use this product near water - for example, near a bath tub, wash bowl, kitchen sink, or laundry tub; in a wet basement; or near a swimming pool; and the like.

8. Accessories

Do not place this product on an unstable cart, stand, tripod, bracket, or table. The product may fall, causing serious injury to a child or adult, and serious damage to the product. Use only with a cart, stand, tripod, bracket, or table recommended by the manufacturer, or sold with the product. Any mounting of the product should follow the manufacturer's instructions, and should use a mounting accessory recommended by the manufacturer.

9. Moving

A product and cart combination should be moved with care.

Quick stops, excessive force, and uneven surfaces may cause the product and cart combination to overturn.

10. Ventilation

Slots and openings in the cabinet are provided for ventilation and to ensure reliable operation of the product and to protect it from overheating, and these openings must not be blocked or covered.

The openings should never be blocked by placing the product on a bed, sofa, rug, or other similar surface. This product should not be placed in a built-in installation such as a bookcase or rack unless proper ventilation is provided or the manufacturer's instructions have been adhered to.

11. Power Sources

This product should be operated only from the type of power source indicated on the marking label. If you are not sure of the type of power supply to your home, consult your product dealer or local power company. For products intended to operate from battery power, or other sources, refer to the operating instructions.

12. Grounding or Polarization

This product is equipped with a three-wire grounding-type plug a plug having a third (grounding) pin. This plug will only fit into a grounding-type power outlet. This is a safety feature. If you are unable to insert the plug into the outlet, contact your electrician to replace your obsolete outlet. Do not defeat the safety purpose of the grounding-type plug.

13. Power-Cord Protection

Power-supply cords should be routed so that they are not likely to be walked on or pinched by items placed upon or against them, paying particular attention to cords at plug, convenience receptacles, and the point where they exit from the product.

14. Lightning

For added protection for this product during a lightning storm, or when it is left unattended and unused for long periods of time, unplug it from the wall outlet. This will prevent damage to the product due to lightning and power-line surges.

15. Overloading

Do not overload wall outlets, extension cords or integral convenience receptacles as this can result in a risk of fire or electric shock.

16. Object and Liquid Entry

Never push objects of any kind into this product through openings as they may touch dangerous voltage points or short-out parts that could result in a fire or electric shock. Never spill liquid of any kind on the product.

17. Inflammable and Explosive Substance

Avoid using this product where there are gases, and also where there are inflammable and explosive substances in the immediate vicinity.

18. Heavy Shock or Vibration

When carrying this product around, do not subject the product to heavy shock or vibration.

19. Servicing

Do not attempt to service this product yourself as opening or removing covers may expose you to dangerous voltage or other hazards. Refer all servicing to qualified service personnel.

20. Damage Requiring Service

Unplug this product from the wall outlet and refer servicing to qualified service personnel under the following conditions:

- a. When the power-supply cord or plug is damaged.
- b. if liquid has been spilled, or objects have fallen into the product.
- c. If the product has been exposed to rain or water.
- d. If the product does not operate normally by following the operating instructions. Adjust only those controls that are covered by the operating instructions as an improper adjustment of other controls may result in damage and will often require extensive work by a qualified technician to restore the product to its normal operation.
- e. If the product has been dropped or damaged in any way.
- f. When the product exhibits a distinct change in performance-this indicates a need for service.

21. Replacement Parts

When replacement parts are required, be sure the service technician has used replacement parts specified by the manufacturer or have the same characteristics as the original part.

Unauthorized substitutions may result in fire, electric shock, or other hazards.

22. Safety Check

Upon completion of any service or repairs to this product, ask the service technician to perform safety checks to determine that the product is in proper operating condition.

23. Wall or Ceiling Mounting

The product should be mounted to a wall or ceiling only as recommended by the manufacturer.

24. Heat

The product should be situated away from heat sources such as radiators, heat registers, stoves, or other products (including amplifiers) that produce heat.

WICHTIGE SICHERHEITSANWEISUNGEN

1. Alle Anweisungen lesen.

Vor Betrieb des Erzeugnisses sollten alle Sicherheits- und Bedienungsanleitungen gelesen werden.

2. Die Anweisungen aufbewahren.

Die Sicherheits- und Bedienungsanleitungen sollten fünftigen Bezug aufbewahrt werden.

3. Warnungen beachten.

Die Warnungen auf dem Erzeugnis und in den Bedienungsanleitungen sollten beachtet werden.

4. Anweisungen befolgen.

Alle Bedienungsanleitung- und Verwendungsanweisungen sollten befolgt werden.

5. Reinigung

Den Stecker des Geräts vor Reinigung aus der Steckdose ziehen. Keine flüssigen Reinigungsmittel oder Aerosolreiniger verwenden. Zum Reinigen einen feuchten Lappen verwenden.

6. Zubehör

Nur vom-Hersteller des Erzeugnisses empfohlenes Zubehör verwenden, da es sonst zu Störungen kommen kann.

7. Wasser und Feuchtigkeit

Dieses Erzeugnis nicht in der Nähe von Wasser verwenden - z.B, in der Nähe einer Badewanne, eines Waschbeckens, einer Küchenspüle, eines Waschzubers, in einem nassen Keller, in der Nähe eines Schwimmbeckens usw.

8. Aufstellung

Das Erzeugnis nicht auf einen instabilen Wagen, Stand, Dreifuß, Träger oder Tisch stellen.

Das Erzeugnis kann sonst herunterfallen und ein Kind oder einen Erwachsenen schwer verletzen.

Außerdem kann das Gerät schwer beschädigt werden. Nur mit einem Wagen, Stand, Dreifuß, Träger oder Tisch verwenden, der vom Hersteller empfohlen oder mit dem Erzeugnis verkauft worden ist. Für jegliche Anbringung sollten die Anweisungen des Herstellers befolgt werden, und das vom Hersteller empfohlene Anbringungszubehör sollte verwendet werden.

9. Eine Kombination von Erzeugnis und Wagen sollte vorsichtig bewegt werden.

Schneller Halt, übermäßige Krafteinwirkung und unebene Oberflächen können Umkippen der Kombination von Erzeugnis und Wagen verursachen.

10. Ventilation

Schlitze und Öffnungen im Gehäuse dienen der Ventilation. Sie sind für zuverlässigen Betrieb des Gerätes und Schutz vor Überhitzung erforderlich und dürfen nicht blockiert oder abgedeckt werden.

Die Öffnungen sollten niemals dadurch blockiert werden, daß, das Gerät auf ein Bett, ein Sofa, einen Teppich oder eine ähnliche Oberfläche gestellt wird.

Das Gerät sollte nur dann in Einbauinstallation wie in einem Bücherschrank oder einem Gestell verwendet werden, wenn angemessene Ventilation vorgesehen ist bzw. Die Anweisungen des Herstellers befolgt worden sind.

11. Stromversorgung

Dieses Erzeugnis sollte nur an der auf dem Typenschild angegebenen Stromversorgungsart betrieben werden. Wenn Sie nicht sicher sind, was für eine Stromversorgung Sie haben, so wenden Sie sich bitte an Ihren Erzeugnishändler oder an das lokale Elektrizitätswerk. Beziehen Sie sich für Batteriebetrieb oder andere Stromquellen vorgesehene Erzeugnisse bitte auf die Bedienungsanleitungen.

12. Erdung oder Polarisierung

Dieses Erzeugnis ist mit einem Schutzkontaktstecker mit drei Leitern ausgerüstet, mit einem Erdungskontakt. Dieser Stecker paßt nur in ein schuko-Steckdose. Dies ist eine Sicherheitsmaßnahme. Wenn Sie den Stecker nicht in die Steckdose stecken können, so wenden Sie sich bitte an ihren Elektriker, damit er die veraltete Schutz des Schutzkontaktsteckers unwirksam.

13. Netzkabelschutz

Netzkabel sollten so verlegt werden, daß möglichst nicht darauf getreten wird und daß sie nicht eingeklemmt werden, mit besonderer Beachtung der Kabel an Stackern, Verlängerungskabeln und dem Austritt des Kabels aus dem Erzeugnis.

14. Blitzschlag

Für zusätzlichen Schutz des Erzeugnisses während eines Gewitters oder bei Nichtverwendung für lange Zeit den Stecker aus der Steckdose ziehen. Dies verhindert Beschädigung durch Blitzschlag und Netzspannungstöße.

15. Überlastung

Wandsteckdosen, Verlängerungskabel und eingebaute Bequemlichkeitssteckdosen nicht überlasten, da dies Feuer oder elektrischen Schlag verursachen kann.

16. Eindringen von Fremdkörpern und Flüssigkeit

Niemals Objekte irgendwelcher Art durch die Öffnungen in das Gerät schieben, da diese unter hoher Spannung stehende Teile berühren oder kurzschließen können, wodurch es zu Feuer oder elektrischem Schlag kommen kann. Niemals Flüssigkeiten irgendwelcher Art auf das Erzeugnis verschütten.

17. Entflammbare und explosive Substanzen

Vermeiden Sie Verwendung dieses Erzeugnisses an Orten mit Gasen bzw. entflammbaren oder explosiven Substanzen in der direkten Umgebung.

18. Starke stöße oder Vibrationen

Setzen Sie das Erzeugnis beim Transport nicht starken Stößen oder Vibrationen aus.

19. Wartung

Versuchen Sie nicht, dieses Erzeugnis selbst zu warten, da Sie sich durch Öffnen bzw. Entfernen von Abdeckungen hohen Spannungen und sonstigen Gefährdungen aussetzen können.

Beziehen Sie sich für jegliche Wartung auf qualifiziertes Wartungspersonal.

20. Beschädigung, die Wartung erfordert

Ziehen Sie den Stecker dieses Erzeugnisses aus der Steckdose und wenden Sie sich an qualifiziertes Wartungspersonal, wenn eine der folgenden Bedingungen vorliegt:

- a. Wenn das Netzkabel oder der Stecker beschädigt ist.
- b. Bei Eindringen von Flüssigkeit oder Fremdkörpern in das Gerät.
- c. Wenn das Erzeugnis Regen oder Wasser ausgesetzt worden ist.
- d. Wenn das Erzeugnis bei Befolgen der Bedienungsanleitungen nicht normal funktioniert.

Nur die Regelelemente verstellen, die in den Bedienungsanleitungen behandelt werden, da unangemessene Einstellung anderer Regelelemente Beschädigung verursachen kann und oft beträchtliche Arbeit durch einen qualifizierten Techniker erfordert, um das Erzeugnis wieder, zu normalem Betrieb zurückzubringen.

- e. Wenn das Erzeugnis fallen gelassen oder beschädigt worden ist.
- f. Wenn das Erzeugnis eine klare Änderung in der Leistung zeigt-dies weist darauf hin, daß Wartung erforderlich ist.

21. Ersatzteile

Wenn Ersatzteile erforderlich sind, darauf achten, daß der Wartungstechniker nur die vom Hersteller festgelegten Ersatzteile oder Teile mit den gleichen Charakteristiken wie die ursprünglichen Teile verwendet. Unautorisierte Ersatzteile können Feuer, elektrischen Schlag oder sonstige Gefährdungen verursachen.

22. Sicherheitsprüfung

Bitten Sie den Wartungstechniker nach der Vollendung von Wartung oder Reparaturarbeiten an diesem Erzeugnis um die Durchführung von Sicherheitsprüfungen, um zu bestimmen, daß das Erzeugnis im angemessenen Betriebszustand ist.

23. Anbringung an der Wand oder an der Decke

Das Erzeugnis sollte nur entsprechend den Empfehlungen des Herstellers an einer Wand oder an der Decke angebracht werden.

24. Wärme

Das Erzeugnis sollte fern von Wärmequellen wie Radiatoren, Heizwiderständen, Öfen und anderen Wärme erzeugenden Erzeugnissen (einschließlich Verstärkern) aufgestellt werden.

MISES EN GARDE IMPORTANTES

1. Lire les instructions

Lire toutes les instructions de sécurité et de fonctionnement avant de faire fonctionner l'appareil.

2. Conserver ces instructions

Conserver les instructions de sécurité et de fonctionnement à des fins de référence ultérieure.

3. Tenir compte des avertissements

Tous les avertissements qui figurent sur l'appareil et dans le mode d'emploi devront être respectés.

4. Observer les instructions

Observer toutes les instructions de fonctionnement et d'utilisation.

5. Nettoyage

Avant de procéder au nettoyage, débrancher l'appareil de la prise secteur. Ne pas utiliser de produits de nettoyage liquides ou en aérosol.

Nettoyer l'appareil avec un chiffon humide.

6. Fixations

Ne pas utiliser de fixations non recommandées par le fabricant de l'appareil car elles pourraient être source de danger.

7. Eau et humidité

Ne pas utiliser l'appareil à proximité d'eau-par exemple près d'une baignoire, d'un lavabo, d'un évier ou d'un bac à lessive, dans un sous-sol humide, ou près d'une piscine, etc.

8. Accessoires

Ne pas placer l'appareil sur un chariot, un socle, un pied, un support ou une table instables. L'appareil pourrait tomber, blessant grièvement des enfants ou des adultes, et étant sérieusement endommagé.

Utiliser exclusivement le chariot, le socle, le pied, le support ou la table recommandés par le fabricant, ou vendus avec l'appareil. Pour tout montage de l'appareil, respecter les instructions du fabricant, et utiliser à cette fin l'accessoire de montage recommandé par le fabricant.

9. L'appareil monté sur son chariot devra être déplacé avec précaution.

Des arrêts brusques, une force excessive et des surfaces irrégulières pourraient provoquer le renversement de l'ensemble appareil-chariot.

10. Ventilation

Les fentes et les ouvertures du coffret sont prévues pour la ventilation ainsi que pour garantir un fonctionnement en toute sécurité de l'appareil et le protéger de toute surchauffe, et ces ouvertures ne devront donc être ni obstruées ni recouvertes. Ne jamais obstruer les ouvertures en plaçant l'appareil sur un lit, un sofa, un tapis ou toute surface similaire. Ne jamais placer l'appareil dans un support confiné, par exemple une bibliothèque ou une étagère, sans ventilation suffisante ou sans respecter les instructions du fabricant.

11. Sources d'alimentation

L'appareil devra être alimenté exclusivement sur le type d'alimentation indiqué sur l'étiquette signalétique. Si l'on n'est pas sûr du type d'alimentation du local, consulter le revendeur de l'appareil ou la compagnie d'électricité locale. Pour les appareils qui fonctionnent sur batterie ou sur d'autres sources, voir le mode d'emploi.

12. Mise à la terre ou polarisation

L'appareil est doté d'une fiche trifilaire avec mise à la terre, dont la troisième broche assure la mise à la terre. Cette fiche ne rentrera que dans les prises trifilaires de mise à la terre. Ceci est une mesure de sécurité. Si la fiche ne rentre pas dans la prise, faire remplacer la prise défectueuse par un électricien.

Ne pas rendre vaine la mesure de sécurité assurée par cette prise avec mise à la terre.

13. Protection du cordon d'alimentation

Acheminer les cordons d'alimentation de façon qu'on ne risque pas de marcher dessus ou de les coincer sous un objet placé dessus ou contre eux.

Faire particulièrement attention aux fiches des cordons, à la proximité des prises, et à l'endroit où ils ressortent de l'appareil.

14. Foudre

Pour renforcer la protection de l'appareil pendant un orage, ou si l'on s'en éloigne ou qu'on reste longtemps sans l'utiliser, le débrancher de la source d'alimentation. Ceci permettra d'éviter tout dommage de l'appareil dû à la foudre et aux surtensions de ligne.

15. Surcharge

Ne pas surcharger les prises, rallonges et prises multiples car cela pourrait entraîner un risque de feu ou de choc électrique.

16. Pénétration d'objets et de liquides

Ne jamais enfoncer d'objets d'aucune sorte dans les ouvertures de l'appareil car ils pourraient toucher des points de tension dangereuse ou court-circuiter des pièces, ce qui pourrait provoquer un feu ou un choc électrique. Ne jamais renverser de liquide d'aucune sorte sur l'appareil.

17. Substances inflammables et explosives

Eviter d'utiliser l'appareil en présence de gaz, ainsi qu'à proximité immédiate de substances inflammables et explosives.

18. Chocs ou vibrations violents

Lorsqu'on transporte l'appareil, ne pas le soumettre à des chocs ou des vibrations violents.

19. Réparations

Ne pas tenter de réparer l'appareil soi-même car le fait d'ouvrir ou de retirer les caches risque d'exposer l'utilisateur à des tensions dangereuses notamment. Confier toute réparation à un personnel qualifié.

20. Dommages nécessitant réparations

Débrancher l'appareil de la source d'alimentation et confier les réparations à un personnel qualifié dans les cas suivants:

- a. Lorsque le cordon d'alimentation ou sa fiche sont endommagés
- b. Si du liquide s'est renversé sur l'appareil ou que des objets sont tombés dedans
- c. Si l'appareil a été exposé à la pluie ou à l'eau.
- d. Si l'appareil ne fonctionne pas normalement lorsqu'on observe les instructions d'utilisation.

Ne régler que les commandes couvertes par le mode d'emploi ; en effet, un réglage incorrect des autres commandes pourrait entraîner des dommages et nécessiteront souvent des travaux de réparation coûteux par un technicien qualifié pour remettre l'appareil en état de marche.

e. Si l'appareil est tombé ou qu'il a été endommagé.

f. Si l'appareil affiche une nette modification de ses performances, cela signifie qu'il a besoin d'être réparé.

21. Pièces de rechange

Si l'on a besoin de pièces de rechange, veiller à ce que le technicien de réparation utilise exclusivement les pièces de rechange spécifiées par le fabricant ou des pièces ayant les mêmes caractéristiques que les pièces d'origine. Les pièces de rechange non autorisées risquent de provoquer un feu, un choc électrique et autres dangers.

22. Vérification de sécurité

Après tout travail d'entretien ou de réparation de l'appareil, demander au technicien de réparation d'effectuer les vérifications de sécurité pour s'assurer que l'appareil est en bon état de marche.

23. Montage au mur ou au plafond

L'appareil ne pourra être monté au mur ou au plafond que de la manière recommandée par le fabricant.

24. Chaleur

Eloigner l'appareil des sources de chaleur, telles que radiateurs, appareils de chauffage, cuisinières, et de tout produit engendrant de la chaleur (y compris les amplificateurs).

Contents

Composition(including accessories).....	1	Video Gain Selection	34
Outline and features	2	White and black balance adjustment.....	35
Warnings and cautions when using	4	Electronic Shutter setting.....	40
Note when using	5	Scene File.....	42
Facility names and functions	6	Camera ID setting	43
Lens installation	13	Genlock.....	44
Lens flangeback adjustment	14	Setup Card	45
White shading adjustment	15	Viewfinder Indications.....	48
Camera adapter installation.....	17	Status Indication of Viewfinder Screen ..	49
Microphone installation	18	Status indication of viewfinder Screen...	53
Tripod mounting.....	19	Function menu Screen	54
Shoulder pad position	20	Studio system operation.....	66
Anton-bauer battery pack.....	21	System configuration	70
GM-51 5inch viewfinder attachment.....	22	Service Information	71
VTR connection	24		
Power supply	27		
Viewfinder adjustment.....	28		
Iris Adjustment	31		
Zoom and Macro operation	32		
Optical Filter Selection	33		

Composition (including accessories)

When unpacking the camera, check for the following items and accessories.

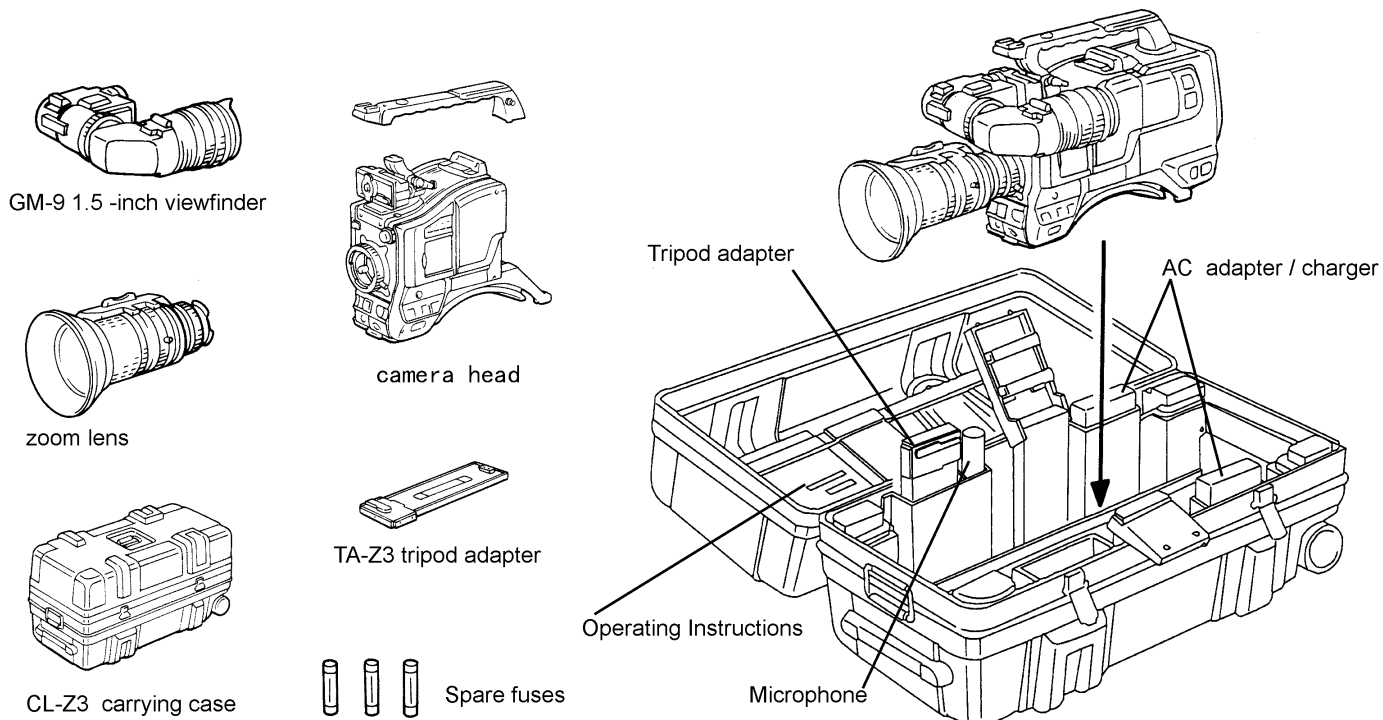

Outline and features

The S-3000W/S-3000 is a new concept 2/3-inch CCD camera that stresses fundamental camera performance.

Advanced functions are realized by the new single chip digital signal processor that improves gradation response, color reproducibility and perceived resolution. The DSP is fully digitized from processor to encoder and incorporates a built-in noise reducing function.

The design fully comprehends the needs of on-site camerawork, with a rugged diecast frame that is light, has a low center of gravity and is convenient to operate.

Premier Performance Starring the Hitachi V-21W / V-21 Digital Camera.

Outstanding Features

Resolution

Horizontal resolution of 750 / 900 TV lines is achieved by the 2/3 inch 600,000 / 620,000 pixel CCDs with microlenses and digital double speed signal processing circuit.

Switchable 16:9 / 4:3 (S-3000W only)

The aspect ratio is switchable between 16:9 and 4:3

to provide broad freedom for program production. Picture quality is also preserved by using digital system.

Newly crafted DSP

Hitachi's pinnacle holding LSI technology combines the entire system from processor to encoder into a single chip to even further reduce the size and power consumption, while enhancing stability.

The 10 bit A/D converter and 13 to 18 bit processor promote high S/N and wide dynamic range.

Signal to noise ratio

An S/N rating of 63 dB is attained by adding low noise circuit technology to a newly developed digital noise reduction circuit. Even at high gain, clear low noise images can be obtained.

Sensitivity (standard 2000 lux, F11)

High gain (+24 dB) and Ultra-Gain (+12 dB) can be combined for up to +36 dB gain increase.

Operation is enabled down to 0.5 lux (F1.4) and 0.8 lux (F1.8).

Setup card

Camera setup data can be saved to a setup card (Compact Flash) and recalled when required.

Flexibility is offered to meet a wide assortment of scene environments.

Versatile CCD drive functions

Preset type 5-step electronic shutter speeds.

Lock Scan to image computer monitors without flicker.

Auto electronic shutter (AES) mode for maintaining a fixed video level.

CC frame mode for improved vertical resolution.

Better picture quality from digital processing

Highlight chroma and auto knee

Color reproduction of highly luminous signals is improved by the highlight chroma circuit, while auto knee automatically compresses high luminosity signals. These add up to wide dynamic range.

Flesh tone detail

Smoothed and softened complexion flatters the talent without sacrificing overall scene detail
Variable detail boost frequency

The center frequency of the detail compensation signal is variable to allow selecting the proper signal to match the scene.

6-vector and linear matrix

Full colorimetry control is built in with linear matrix compensation for color reproduction plus independently variable hue and saturation for six colors to provide wide latitude for subjective expression

Special gamma

Adjusts the gamma rising gain to improve reproduction of dark scene components.

Flare compensation

Outline and features

Extensive operational convenience

Programmable operation switches with functions assigned according to application.

Auto white and shading compensation coupled with lens extender.

Gain, detail, gamma and other settings can be stored in 4 scene files for easy recall. Each optical filter has four white balance memories. A total of 8 memories are used in two white balance memory systems.

Menu screen settings for iris level (fine adjust) and iris peak/average

Computer chip detects scene color temperature changes in real-time and automatically compensates white balance.

Camera ID, date and time mixable with color bar display.

Audio test tone (1 kHz) mixable with color bar.

Microphone input compatible with "phantom" power supply.

Microphone level control when docked with Betacam.

Viewfinder display functions

Settings from tree type menu screen.

Self-diagnostic and display check functions available.

Two mode zebra

Selectable for over-level and within range indication.

Battery remaining

Indicated as a percent when used with Anton/Bauer Digital Magnum series battery.

Safety zone and center mark display

Audio level indicator

REC time display when combined with VTR.

High performance viewfinder (GM-9)

With 600 TV lines resolution for easy focus adjustment.

Large aperture lens for comfortable eye relief.

Front-rear, left-right, and tilt mechanisms allow adjustment to best angle.

Bayonet mount for direct connection to camera without cable.

Rotate 90 degrees upward for convenient carrying.

new low CG design

Main operation switches are grouped forward for easy use.

The low center of gravity design is light (camera head 2.6 kg) and conveniently portable.

Adjustable shoulder pad position plus non-slip finish for comfortable and confident carrying.

combine with assorted VTR models

Adapters and inner modules are available (options) that enable docking and combined use with a flexible choice of video tape recorders.

Combine with portable VTR by using VTR cable.

suggested system configurations

Studio system: RU-Z2/RU-Z3 Camera Base Station, CA-Z32 Camera Adaptor, RC-Z2A/RC-Z21A Camera Control Panel, GM-51 5-inch viewfinder

Small scale studio system: RU-Z1 Remote Operation Unit, CA-Z31 Camera Adaptor, RC-Z1/RC-Z11 Camera Control Panel, GM-51 5-inch viewfinder

Control from personal computer: JU-C20 or JU-Z2, remote control via RS-232C. The JU-Z2 allows controlling multiple cameras from a single computer.

Genlock is applied to the camera even when docked with a VTR. Operation as a video system is enabled while the VTR is recording.

Warnings and cautions when using



WARNING

Viewfinder lens hazard

Do not point the eyelens toward the sun or other bright light source. There is danger of physical burns and loss of eyesight.

Do not place the viewfinder with the lens pointed toward the sun. There is risk of burn damage to the viewfinder interior.



CAUTION

Power supply

The specified power supply input voltage of this camera is 12 VDC. Be sure to use the designated power supply.

Do not disassemble or modify

The camera contains precision internal components. Do not open the cover or disturb switches and controls other than designated. There is risk of impaired performance and damage.

Keep foreign object out of interior

Entry of water, metallic or other foreign materials can cause failure and damage.

Select use and storage locations carefully

Avoid using or storing the equipment in the following types of locations. Impaired performance and damage can be caused.

Extremely hot or cold locations (exceeding -10 to 45 °C), such as in enclosed vehicles.

Subject to strong vibration.

Humid or dusty locations.

Salt spray or corrosive gases.

Strong electromagnetic fields (e.g., near TV or radio transmitters).

Where exposed to rain.

Do not cover or otherwise obstruct camera heat dissipation during operation.



WARNING

Viewfinder high voltage

Do not open the viewfinder cover. There is danger of touching internal high voltage components.



CAUTION

When connecting and disconnecting lens, microphone and other cables, grasp the connector by the body, not the attached cable. Cables can be damaged by pulling on them.

Note when transporting

When transporting by hand, use the carrying case. If shipping by truck or other means, pack in the carrying case, then use further cushioning and pack in a sturdy carton.

Tripod

Use a recommended tripod and install the camera correctly.

Cleaning

Use a photographers air blower to clear dust from the lens and filters. Wipe the case with a soft dry cloth. Do not use volatile solvents, as these may deform the materials.

Fuse replacement

Important: Although spare fuses are provided, the fuse must be replaced only by a qualified service technician.

In event of difficulty: Disconnect from power and contact the nearest Hitachi Denshi service agency.

Note when using

NOTE

***** **CCD characteristic phenomena** *****

The following types of phenomena are innate characteristics of a charge coupled device (CCD) and are not malfunctions. Be aware of these when using a CCD camera for broadcast or other demanding applications.

Smear

When a bright object is picked up, thin trails appear above and below the image. The effect is more pronounced at high electronic shutter speeds.

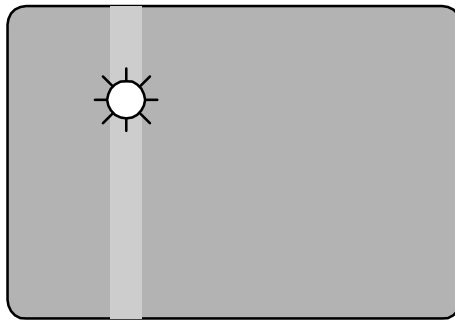

Fixed pattern

When operate at high temperature, a fixed pattern (vertical stripes, white dots) can appear. The pattern is more easily seen when the camera sensitivity is raised.

Facility names and functions

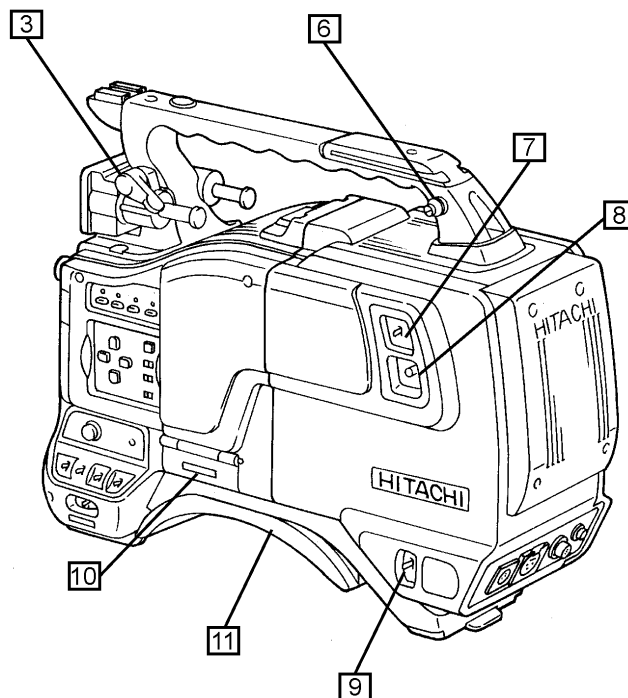
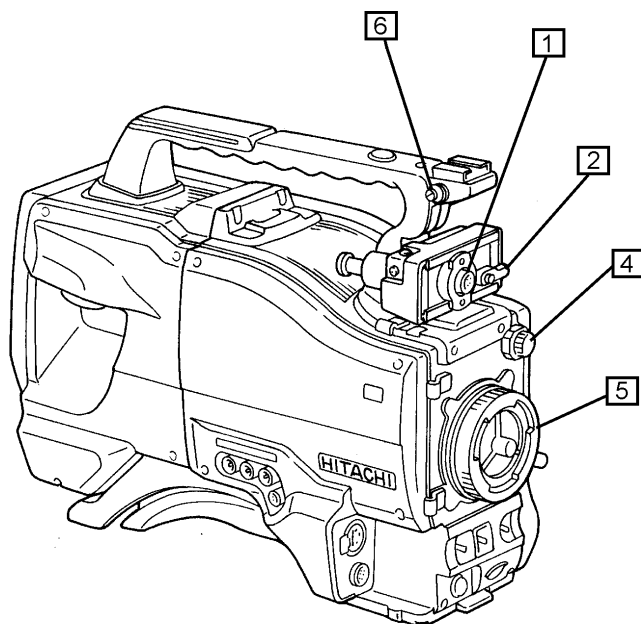

1 Viewfinder connector

Connect the accessory 1.5-inch viewfinder or the separately sold GM-51 5-inch viewfinder.

2 Viewfinder horizontal lock lever

Secures the side to side position adjustment of the 1.5-inch viewfinder.

3 Viewfinder front to rear lock screw

Secures the front to rear position adjustment of the 1.5-inch viewfinder

4 CC/ND filter select knob

Selects filter to match the light source of the scene.

5 Lens mount

Bayonet type lens mount.

6 Shoulder belt hook

Attachment for separately sold shoulder belt.

7 Talk on/off switch

Intercom microphone on/off when connected into a system with the RU-Z2/RU-Z1.

8 Intercom level control

Intercom sound level (volume) adjustment when connected into a system with the RU-Z2/RU-Z1.

9 Power select switch

[BATT-CCU/VTR-EXT]

BATT : When power is supplied via the BATT12V IN connector.

CCU/VTR : When power is supplied via the connector for camera base station or VTR.

EXT : When power is supplied via the DC IN connector.

10 Setup card slot

Slot for inserting setup card.

11 Shoulder pad

Adjustable shoulder pad for comfortable operation. Loosen the 2 screws and adjust the front to rear position.

Facility names and functions

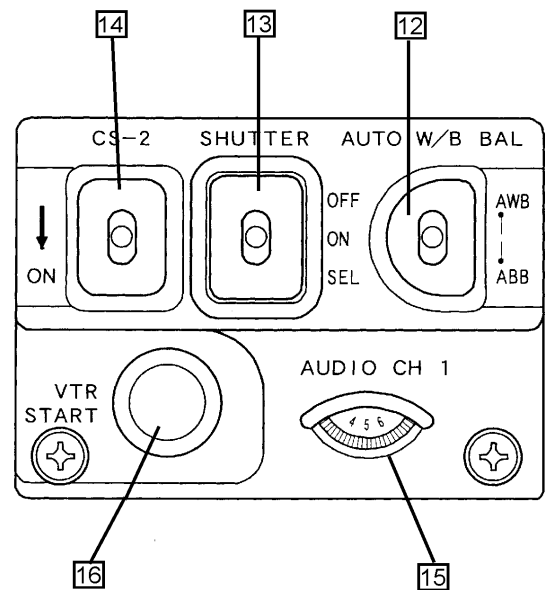
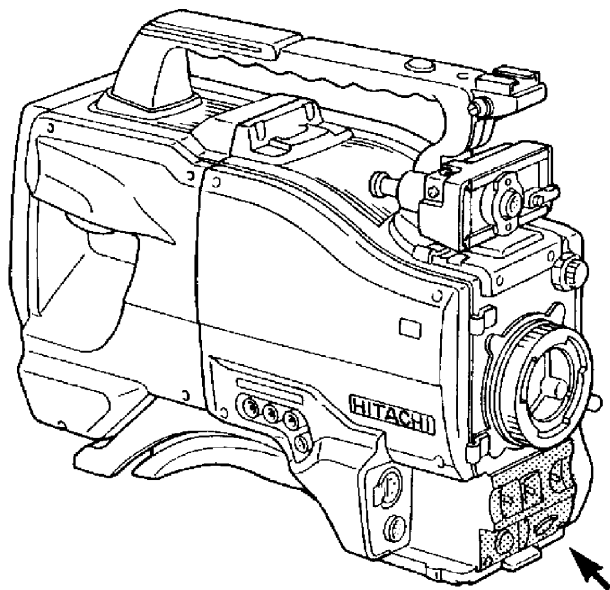

12 Auto white/black balance switch

AWB: Select for automatic white balance adjustment. Set the WHITE BAL switch **20** to A or B to store the adjustment in respective memory A or B.

ABB: Select for automatic black balance adjustment. The adjustment is stored in a special memory.

13 Shutter switch

Set to on to use the electronic shutter. At the SEL position, the shutter speed and mode are changed in the range set beforehand at the setting menu.

14 CS-2 switch

On/off switching for function set at menu.

15 Audio channel 1 recording level control

The audio recording level can be adjusted (only) when connected to a Betacam VTR (BVV-1 or BVV-5).

16 VTR start button

When connected to a VTR in the recording mode, press the button once to start recording, press again to stop recording. Functions as Call button when connected to the RU-Z1/RU-Z2.

Facility names and functions

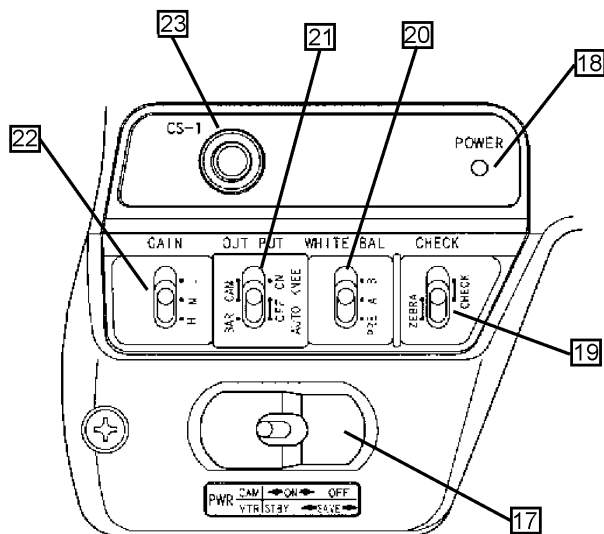
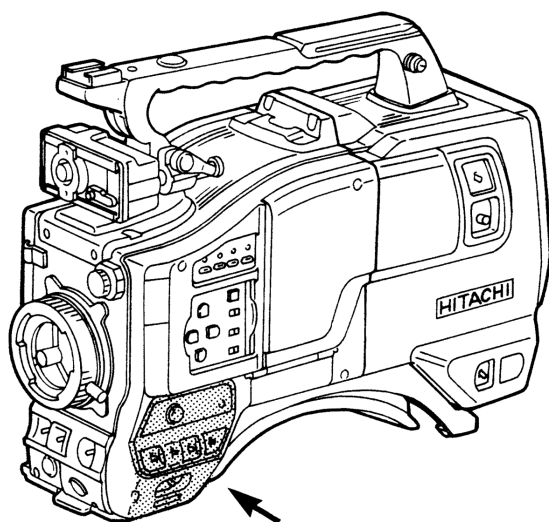

17 Power switch

[VTR STDBY/SAVE、CAM ON/OFF]

Left: (VTR:STDBY、CAM:ON)

Both camera and VTR power on and recording starts.

Center: (VTR:SAVE、CAM:ON)

Camera power on, VTR power save mode

Right: (VTR:SAVE、CAM:OFF)

Camera power off, VTR power save mode.

18 Power LED

Off : Camera power not supplied.

Lights (green): Camera power supplied, but power switch is off.

Lights (red) : Camera power switch on.

19 Check switch

At the Check setting, the viewfinder indicates the status of the camera operating switches, recording elapsed time, audio level and other information.

The Zebra position provides a zebra signal for checking the video signal level on the viewfinder screen.

20 White balance memory switch

PRE: Set to this position when circumstances such as time do not allow adjusting the white balance.

The white balance is set to the memory value for 3200 K.
A or B
When the AUTO W/B BAL switch [12] is set to AWB, the white balance is adjusted automatically according to the Filter knob [4] setting. The adjustment is stored in the selected memory A or B.

21 Output/Auto Knee switch

BARS: Color bar signal output.

Cam, Auto Knee Off

Pickup signal from camera not produced. Auto knee circuit inoperative.

CAM,AUTO KNEE ON

Pickup signal from camera obtained. Auto knee circuit operates.

22 Gain switch

Selects video circuit gain according to scene brightness. Low, medium and high are indicated beforehand in the setting menu. The initial settings are L = 0 dB, M = 9 dB, H = 18 dB.

23 CS-1 switch

On/off for function set by menu.

Facility names and functions

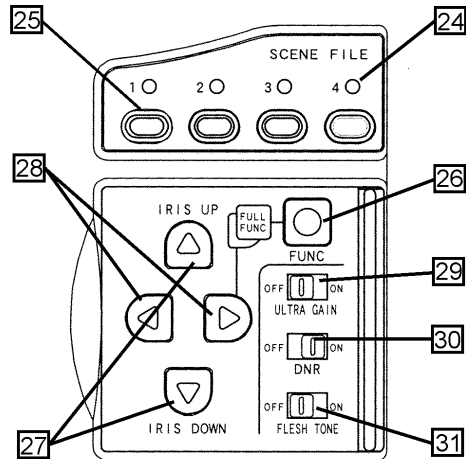
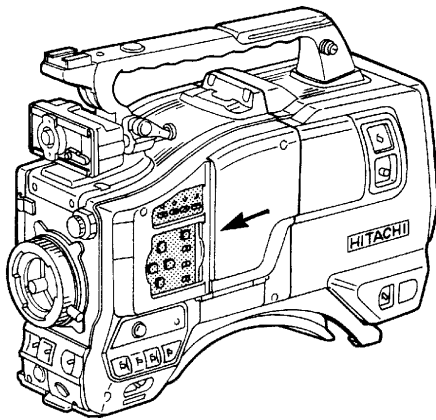

24 Scene file LEDs

Light to indicate the scene file selected by the Scene File buttons **25**.

25 Scene File buttons

Select from among 4 scene files.

26 Function button

Used for changing settings (e.g., detail amount).

27 Up/down buttons

Change the setting selected by the Function button **26**.

28 Left/right buttons

Change the setting selected by the Function button **26**. In the lock scan mode, use for adjusting the shutter speed.

29 Ultra gain on/off switch

ON : Increase sensitivity about 12 dB. Operates only when the sensitivity is above +12 dB (some loss of horizontal resolution).

OFF : Normal mode operation.

30 Digital noise reduction (DNR) on/off switch

ON : Reduces noise during high gain.

OFF : Normal mode operation.

31 Fleshtone on/off switch

ON : Fleshtone detail is moderated. Fleshtone setting is at the DTL sub-menu.

OFF : Normal mode operation.

Facility names and functions

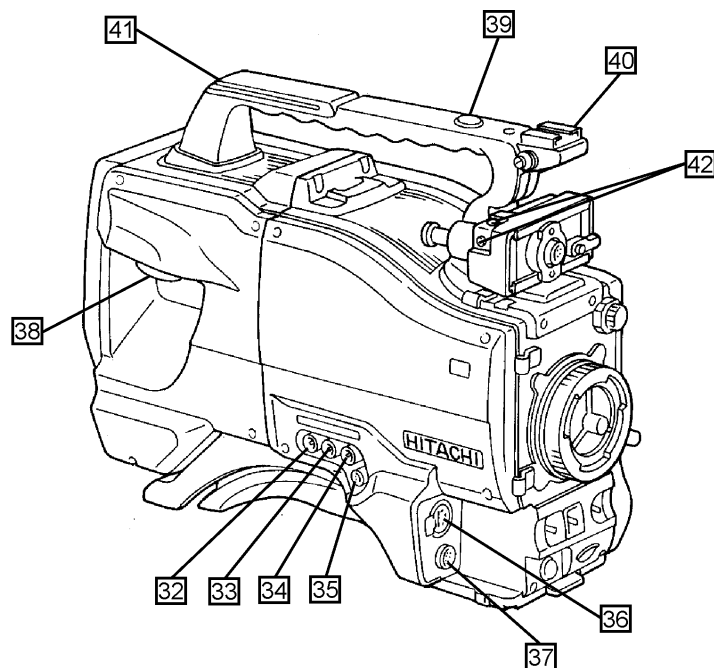

- 32** Video output connector (BNC)
Composite video signal output (1 Vp-p/75Ω).
- 33** Monitor output connector (BNC)
Video signal output for monitor (1 Vp-p/75Ω).
The same character signal as the viewfinder is superimposed on the video signal to allow checking the setting menu from the monitor screen.
- 34** Genlock In connector (BNC)
Reference signal input for applying genlock to the camera.
- 35** Remote control connector (4 pin)
Connection for RC-Z1, RC-Z11, RC-Z2A , RC-Z21A or RC-Z3 camera remote control panel or a personal computer.
- 36** Microphone connector (XLR, 3P)
Connection for separately sold microphone.
Microphone power is supplied from this connector.
- 37** Lens connector (12 pin)
Connection for lens cable.
- 38** CCU/VTR connector (28 pin for CA-Z31, 26 pin for CA-Z32)
Use separately sold cable to connect a portable VTR or RU-Z1/RU-Z2/RU-Z3 camera base station.
- 39** Lighting shoe screw hole (1/4-inch 20UNC)
- 40** Accessory shoe
A small spotlight can be attached without the light striking the lens, viewfinder or microphone.
- 41** 5-inch viewfinder attachment
The GM-51 5-inch viewfinder can be attached by using the AT-30 adapter.
- 42** Mic holder screw hole
A separately sold MH-Z3 mic holder can be attached.

Facility names and functions

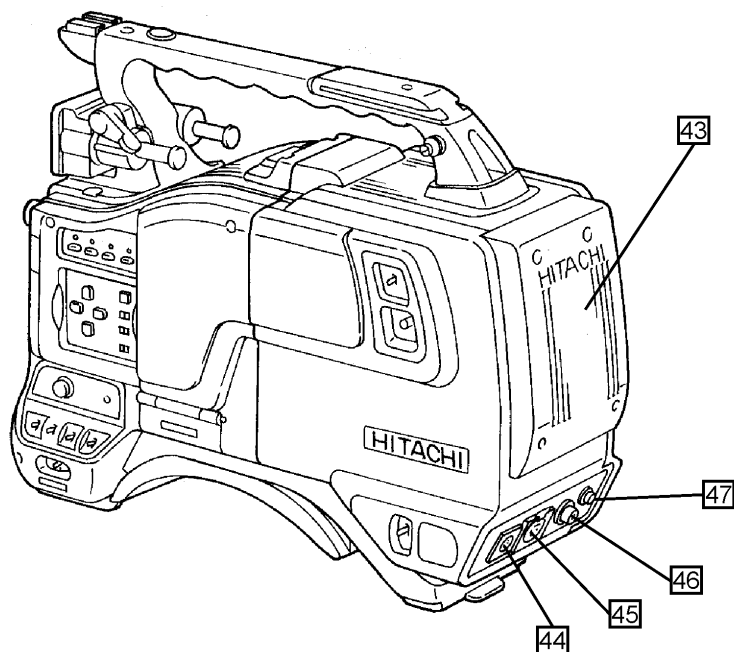

43 Rear cover

Contains connections for battery and extension adapter, etc.

44 DC IN connector (XLR, 4P)

Connect the separately sold AC adapter for operating from AC power.

45 Intercom connector (XLR, 5P)

Connect intercom headset (MT-12MF) when using the RU-Z1/RU-Z2/RU-Z3

46 150 V Out connector (5 pin, CA-Z32 only)

Connect 150 V to 12 V power supply adapter when using a large size lens.

47 Audio monitor connector (minijack)

Connect an earphone (8 to 10 Ω) to monitor microphone or VTR playback sound.

Facility names and functions

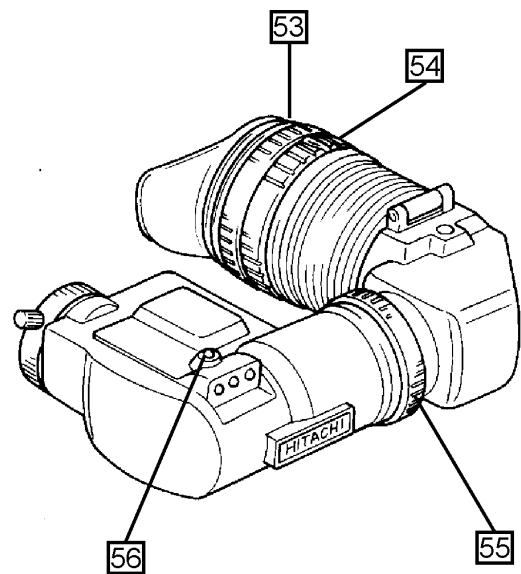
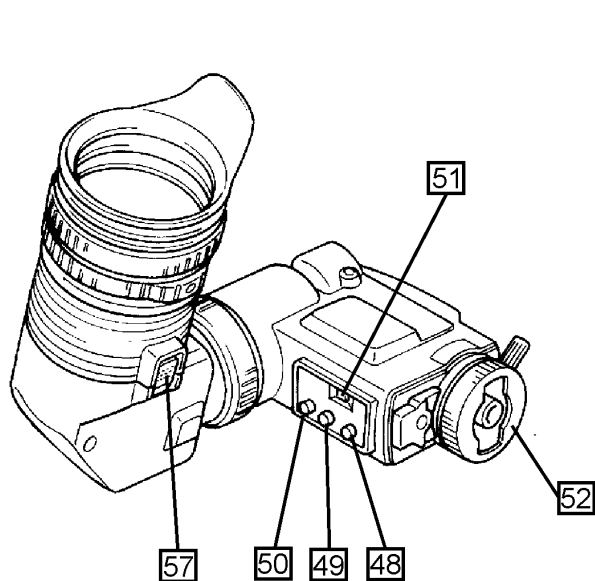

48 Brightness control

Adjusts viewfinder screen brightness. Does not affect camera output signal.

49 Contrast control

Adjusts viewfinder screen contrast. Does not affect camera output signal.

50 Peaking control

Adjusts viewfinder video contours for easier focus adjustment. Does not affect camera output signal.

51 External tally switch

ON : External tally lamp lights.

OFF : External tally lamp does not light.

52 Camera connector

Connects viewfinder to camera.

53 Eyecup

54 Visibility adjust ring/knob

Adjust for best viewfinder image clarity according to the operator.

55 Tightening ring

Secures eyecup after adjusting the vertical angle.

56 External tally indicator

When the external tally switch **51** is on, lights in conjunction with the viewfinder screen tally.

57 Flip-up button

Lens installation

1. Raise the lens lever and remove the mount cap.

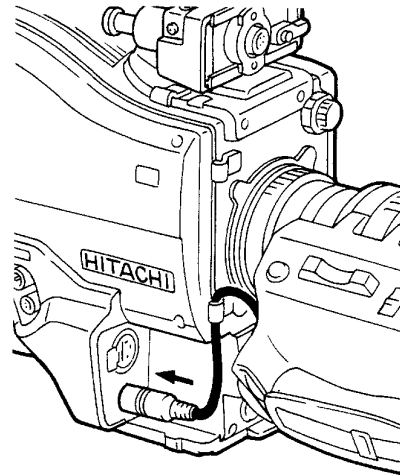
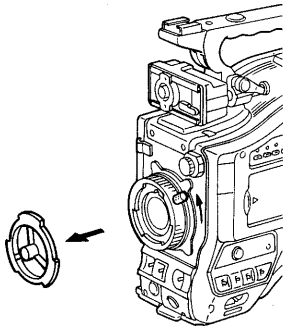

2. Align the lens center mark with the indent at the upper part of the lens mount and install the lens

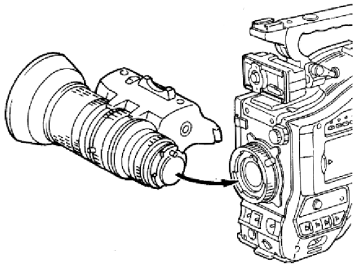

Refer to the lens instructions when using the lens.

Notes:

The following adjustments may be required according to the type of lens.

- 1 . Lens flangeback
- 2 . Lens auto iris speed
- 3 . Lens white shading (with camera)

3. Lower the lens lever to secure the lens.

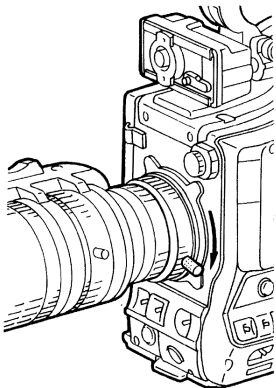

4. Engage the cable with the cable clamp and connect it to the lens connector.

Lens flangeback adjustment

When operating a zoom lens, if the focus is not precisely aligned at both the telephoto and wide angle extremes of the lens, the flangeback (distance from the lens mounting plane to the focal plane) is adjusted. This adjustment is generally required only once unless the lens is replaced.

Reference

Refer to the lens operating instructions regarding the component positions for flangeback adjustment.

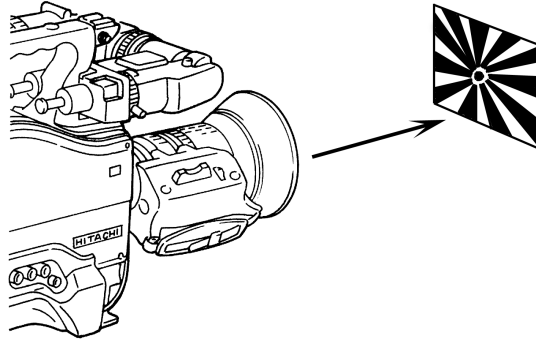

Flangeback adjustment

1. Set the lens iris for manual operation.
2. Open the iris. Set a flangeback adjusting chart about 3 meters distant and adjust the lighting to obtain the correct video output level. If the video level is too high, use a CC/ND filter or electronic shutter.
3. Loosen the Ff ring setscrew.
4. By hand or motor, set the zoom ring to the telephoto position.
5. Observe the flangeback chart image and turn the distance ring to adjust the focus.
6. Set the zoom ring to the wide angle position.
7. Turn the Ff ring and adjust the focus. Use care not to turn the distance ring.
8. Repeat this process until focus is obtained at both telephoto and wide angle settings.
9. Securely tighten the Ff ring setscrew.

Also, see the lens operating instructions.

White shading adjustment

White shading adjustment is recommended after replacing the lens. The adjustment relates to the camera vertical coloration. If the lens includes an extender, the shading can be optimized for both extender on and off modes.

(Vertical coloration refers to an effect whereby the image of an overall white sheet of paper tends toward green at the top and magenta at the bottom, or vice versa.)

Adjustment steps



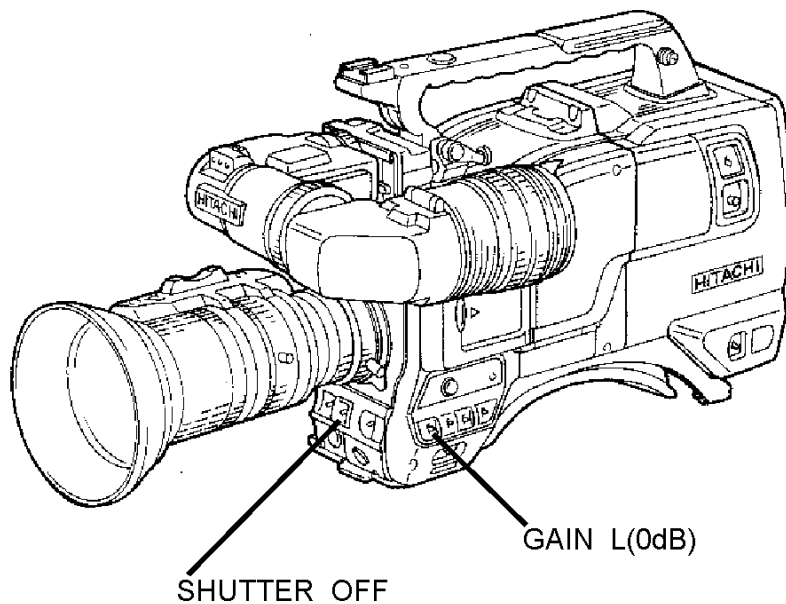

1. Install the lens on the camera (be sure to connect the lens cable).
2. Set the electronic shutter to off and the gain to L (0 dB).



3. If provided, set the lens extender to off.
4. Notice that flicker can occur with fluorescent or mercury lighting. Therefore, use sunlight or halogen as the light source.

In the auto iris mode, check that the iris is between F4 and F11. If necessary, adjust the light source position (be sure the electronic shutter is off).

White shading adjustment

5. **FUNC**     Operate the Function buttons to produce the Full Function mode Special Set page, then shift to the WHT Shading page.
6. At the WHT Shading page, shift the cursor to Auto Setup.
7. Press the < direction button for about 1 second to conduct AWB. Then press the > direction button for about 1 second to adjust white shading. The viewfinder top and bottom cursors flash to indicate automatic white shading adjustment in progress. The cursors extinguish at the end of adjustment.
8. Set the extender (if provided) to on and repeat the above step.
9. Close the Function menu.

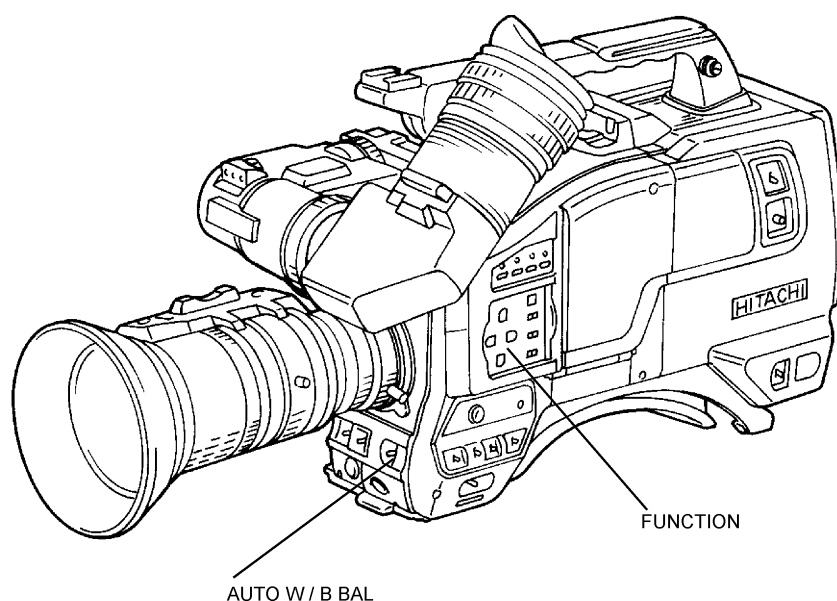

White shading adjustment is completed by the above. The adjustment is stored in a nonvolatile memory and ordinarily does not need to be repeated even if the power is switched off.

Notes:

1. Precise adjustment may not be obtainable with some special lenses.
2. Even after adjustment, some coloration may occur near the open iris setting. This is due to lens and optical system characteristics and is not a malfunction.

Camera adapter installation



1. Align the adapter with the camera guide and guide pin. Attach the adapter and engage the connector.
2. Tighten the screws provided with the handle to secure the camera adapter to the camera.
3. Install the handle with two screws.

CAUTION

Tighten the screws completely. Check for absence of wobble between the camera and adapter.

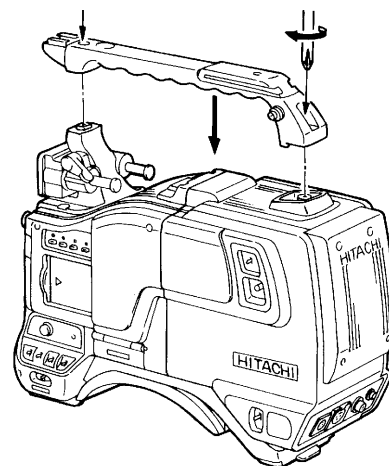

Microphone installation

Mic holder attachment

Attach the MH-Z3 microphone holder (separately sold).

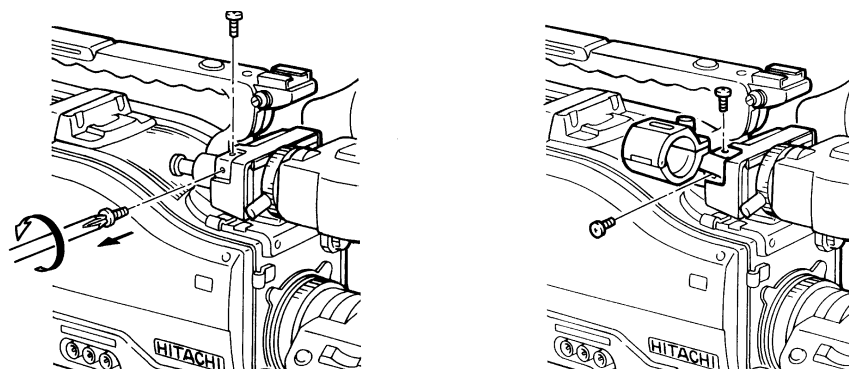

Microphone

Install the (separately sold) MC-Z2/Z3 microphone and C-300MA microphone cable as follows.

1. Attach the MC-Z2/Z3 microphone to the mic holder.
2. Connect the C-300MA mic cable to the microphone.
3. Secure the cable in the cable clamp and connect to the MIC IN connector.

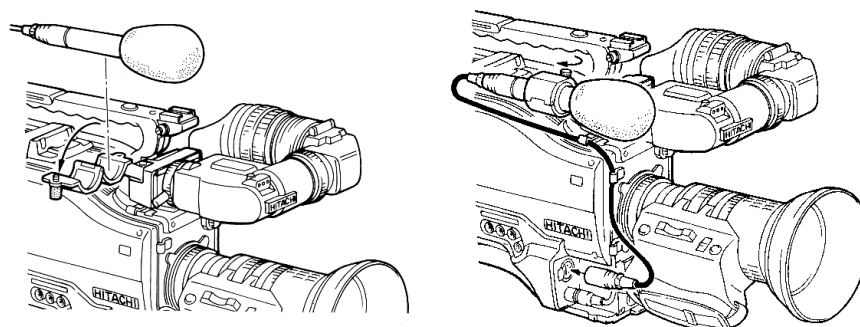

Microphone power and sensitivity

Set from Function 2 menu screen.

1. Phantom power (+48 V) can be supplied. Set to on for the MC-Z2/Z3 or ME-66. Set to off for an internal battery or dynamic type microphone.
2. Select the microphone sensitivity.

FUNCTION 2	
M. BLACK	:0
DYNA CHROMA	:ON
DNR MODE	:MODE1
ZEBRA TYPE	:1
LEVEL	:MID
CS-1 SW	:QUICK FOCUS
CS-2 SW	:CONTRAST
MIC SENSE	:MID
PHANTOM	:OFF
F.AUTO SEL	:->

Earphone connection

Sound can be monitored by connecting a conventional earphone (8 to 10Ω) to the AUDIO MON jack.

Tripod mounting

Use the accessory TA-Z3 tripod adapter to mount the camera on a tripod.

1. Securely attach the tripod adapter to the tripod. Shift the adapter screw position to obtain the best balance. The adapter can accept two types of screws. Use the screw hole that matches the tripod.
2. Secure the camera on the tripod adapter. Align the hooks of the camera and adapter, then turn the lock lever in the direction indicated by the arrow. A click sound can be heard at the locked position.
3. Slightly loosen the tripod screw and again check the balance. Shift the adapter to the optimum position and securely tighten the tripod screw.

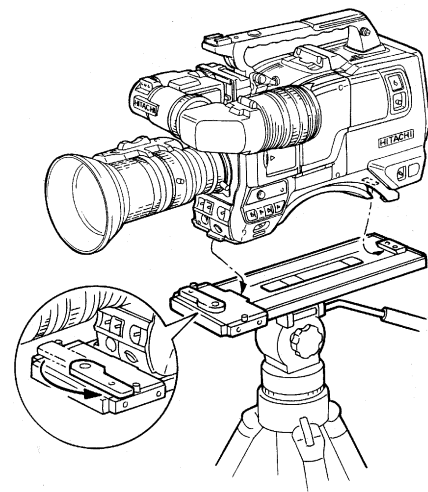
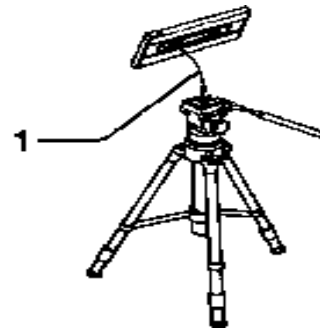

Detaching

Press the red lock pin and turn the lever in the arrow direction. Remove the camera

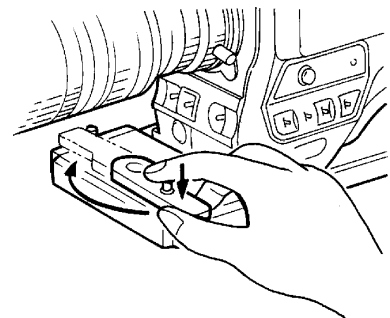
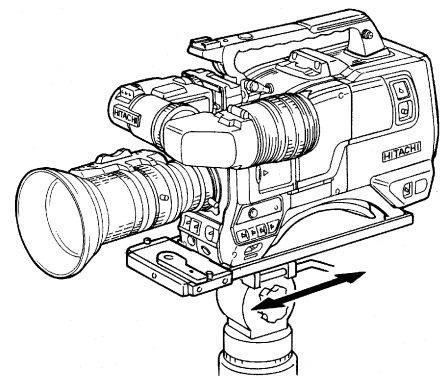

CAUTION

1. The weight can exceed 5 kg with the lens and 10 kg with a VTR. Use a sturdy tripod that can support more than 10 kg. A large size tripod can provide both stability and smooth operation.
2. A screw hole is located near the camera tripod adapter hook. Do not use this hole for attaching to the tripod. There is risk of dropping.

Shoulder pad position

The shoulder pad can be shifted up to 15 mm in either direction from the center (factory) position. The position can be adjusted for comfortable operation.

1. Loosen 2 screws.
2. Slide the pad forward or rearward to the best position.
3. Tighten the 2 screws.

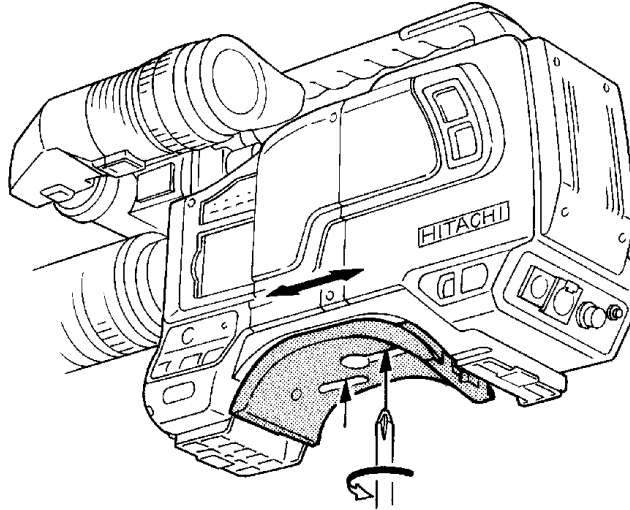

Anton-Bauer battery pack

Anton-Bauer battery pack

Procure the separately sold battery holder to operate the camera from an Anton-Bauer battery.

1. Use 4 screws to attach the battery holder to the rear of the camera adapter.

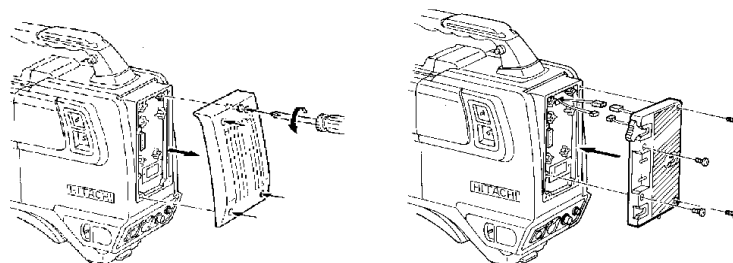

Note: The optional battery holder connecting cable is required. Consult Hitachi denshi service center.

2. Attach the battery pack. Insert and slide the battery pack.

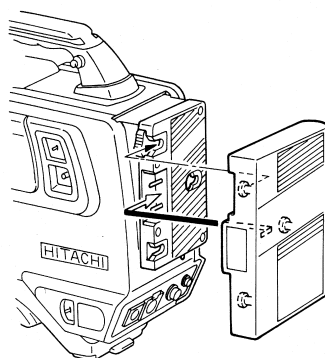

3. Set the camera adapter Power Select switch to BATT.
4. To remove the battery, set the battery holder detaching lever fully downward, then slide the battery as shown by the arrow to remove it.

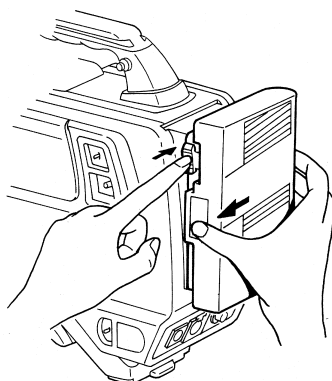

Note:

The intelligent/ultra basketry can also be used. The intelligent battery can automatically detect battery remaining of more than 10 %. The viewfinder indicates battery remaining as a percent. Below 10 %, the indication is voltage.

If external power is supplied after detection, the indication is intelligent battery remaining amount.

GM-51 5-inch viewfinder attachment

Use the separately sold AT-30 viewfinder adapter when installing the GM-51 5-inch viewfinder.

1. Raise the lock lever of the AT-30 horizontally and remove the viewfinder mounting screw from the AT-30. Insert this screw in the bottom of the GM-51. Insert the screw together with the GM-51 into the AT-30 and set the lock lever forward, then turn the lever clockwise to secure it.

Warning: Be sure to tilt the lock lever forward and turn it clockwise to tighten it. If tightening is overlooked, the GM-51 can drop and pose a risk of injury.

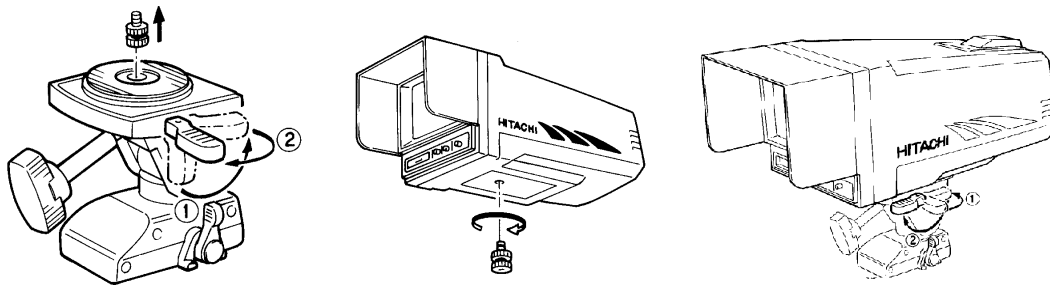

2. Insert the GM-51 and AT-30 into the slot at the rear of the handle and slide them forward until a latching sound is heard from the release knob.

Warning: Press the release knob to where a latching sound is audible. If not securely attached, the entire viewfinder can drop and pose a risk of injury.

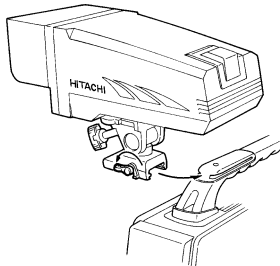

Set lock lever B of the AT-30 rearward.

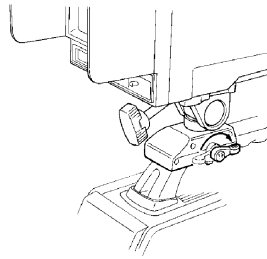

Turn lock lever B clockwise and check for absence of wobble at the AT-30 mounting.

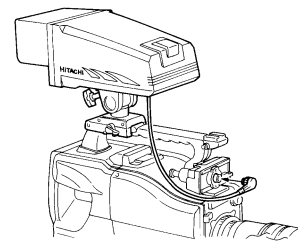

Connect the viewfinder cable to the camera viewfinder connector.

GM-51 5-inch viewfinder attachment

3. Removal

Disconnect the viewfinder cable.

Turn the AT-30 lock lever B counter-clockwise and pull the release knob to allow removing both the GM-51 and AT-30.

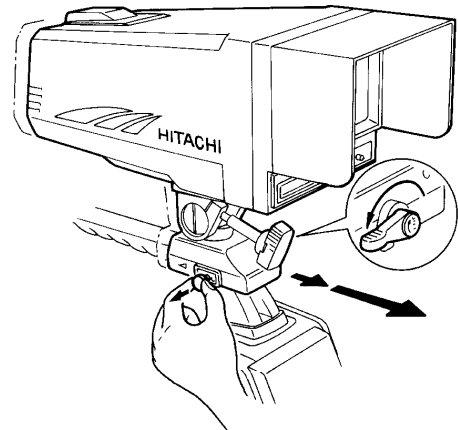

VTR connection

VTR docking

Examples of compatible VTRs

Sony	DNV-5 (BETACAM SX)
	BVV-5 (BETACAM)
	PVV-3 (BETACAM SP2000PRO)
	DSR-1 (DVCAM)
Matsushita (Panasonic)	AJ - 45H (M Promind)
	AJ-D90 (DVCPRO)
JVC	BR-S422 (S-VHS)
	BR-D40 (DIGITAL-S)

Note:
VTR examples are shown only for general reference. Model names and specifications are subject to change.

Required inner modules (separately sold)

Note:

Refer to the VTR and inner module instructions for details regarding installation.

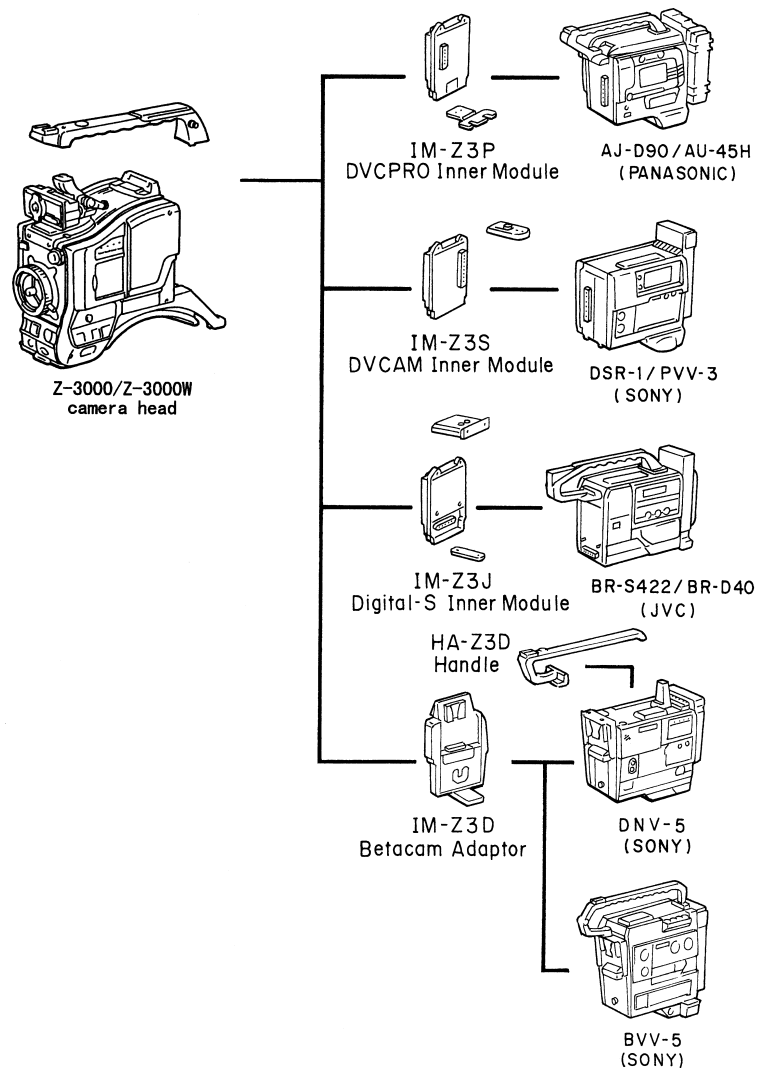

VTR connection

VTR types and connections

System	Camera setting (see Note)		VTR cable		VTR inner module	Main VTR
	VIDEO(VTR)	AUDIOLEVEL	CA-Z31	CA-Z32		
BETACAM	COMP	-60dB	- - -	- - -	IM-Z3D	BVV-5, DNV-5
			- - -	- - -	IM-Z3S	PVV-3
			C-201TE C-501TE	C-201TB C-501TB	- - -	BVW-50
DVCAM	COMP	-60dB	- - -	- - -	IM-Z3S	DSR-1
M2	COMP	-60dB	- - -	- - -	IM-Z3P	AU-45H
			C-201TE C-501TE	C-201TB C-501TB	- - -	AU-520
			- - -	- - -	IM-Z3P	AJ-D90
DVCPRO	COMP	-60dB	- - -	- - -	IM-Z3P	AJ-D90
S-VHS	Y/C	-20dB	- - -	- - -	IM-Z3P	BR-S422
			C-201TD	C-301TF	- - -	(AG-7400) (BR-S400)
DIGITAL-S	COMP	-20dB	- - -	- - -	IM-Z3P	BR-D40
U-matic	VBS	-60dB	C-201TD	C-301TF	- - -	VO-8800

- Note:
- Set at the System sub-menu of the Function menu screen.
 - When using a dockable VTR with inner module, camera setting is unnecessary. The System sub-menu indicates Auto.

SYSTEM	
VF DTL CONT	:MENU
VIDEO(VTR)	:AUTO
AUDIO LEVEL	:AUTO
CLOSE LIMIT	:
IRIS SPEED	:0
REMOTE	:9600BPS
BATT TYPE	:12V
ALARM SET	:11.5V

VTR connection

VTR power save

When the camera PWR switch is set to VTR Save, the VTR types operate as follows.

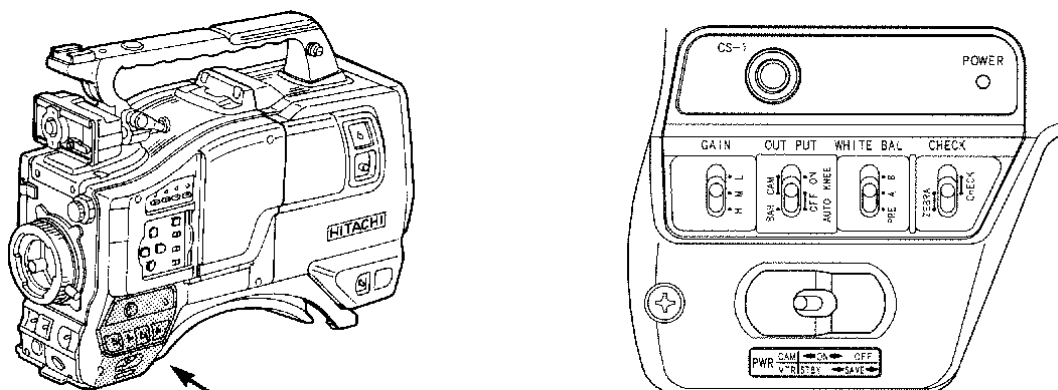

VTR	Operation
DNV-5, BVV-5, PVV-3, DSR-1, AU-45H, AJ-D80,	The VTR goes to power save mode to avoid battery depletion
BR-S422, BR-D40	All VTR operations inhibited.

REC review and playback monitor

When the VTR includes a recording review function, in the VTR REC Pause mode, press the lens RET button to view the final few seconds of the recording in the viewfinder. By setting the VTR to the playback mode, the playback image automatically appears in the viewfinder, while the sound can be heard with an earphone.

If the VTR does not have a REC review function, the playback mode image can be seen while the RET button is held depressed.

Operation differs according to the VTR.

Power supply

When the CA-Z31/CA-Z32 is installed, power can be supplied as follows. Set the Power Select switch accordingly.

1. Connect the separately sold AP-60 AC adapter to the DC IN connector.
2. Connect the camera base station or VTR to the CCU/VTR connector.
3. Connect Anton-Bauer battery.

(Note)

When a Betacam type VTR is directly connected to the camera, power is supplied from the VTR.

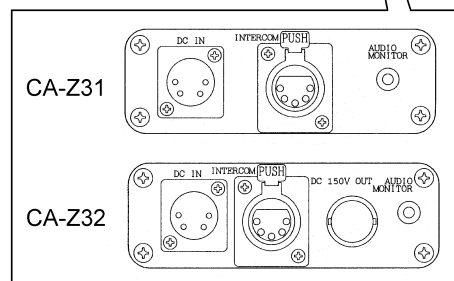
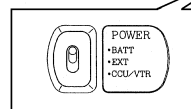
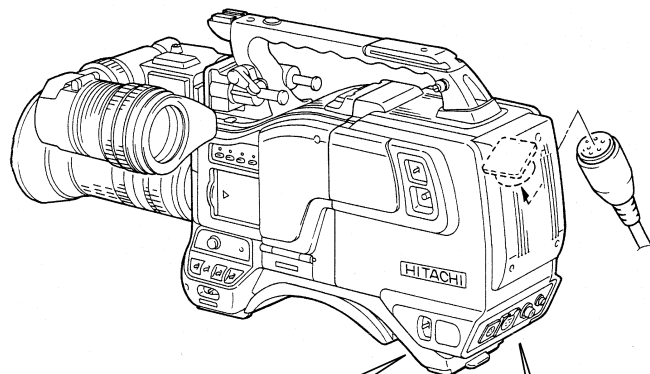

Caution

1. The DC IN connector can accept 10.5 to 17 VDC. However, use a designated power supply of 12 to 13 VDC. Voltage exceeding 17 VDC can cause damage.
2. In not using the equipment for an extended period of time, set the AC adapter switch to off. If a battery is connected, remove the battery.

Voltage down display

As the voltage declines, B lights in the viewfinder. The System sub-menu of the Special Set menu sets the battery type.

Alarm Set adjusts the voltage at which B lights.

Battery type	Alarm operating voltage
12.0V	10.5V ~ 11.6V
13.5V	11.7V ~ 12.8V
14.4V	12.9V ~ 14.0V

Power Select switch positions

Power supply	Setting position
1	EXT
2	EXT
3	CCU/VTR
4	BATT

SYSTEM

VF DTL CONT : MENU
 VIDEO(VTR) : COMP
 AUDIO LEVEL : -60dB
 CLOSE LIMIT :
 IRIS SPEED : 0
 REMOTE : 9600BPS
 BATT TYPE : 12V
 ALARM SET : 11.5V

Viewfinder adjustment

Viewfinder installation

1. Turn the lock lever as indicated by the arrow to secure the viewfinder guide.
2. Turn the viewfinder lock lever fully counter-clockwise.
3. Align the 2 viewfinder guide pins with the camera guide holes and insert the viewfinder.
4. Secure the lock lever firmly in the arrow direction.

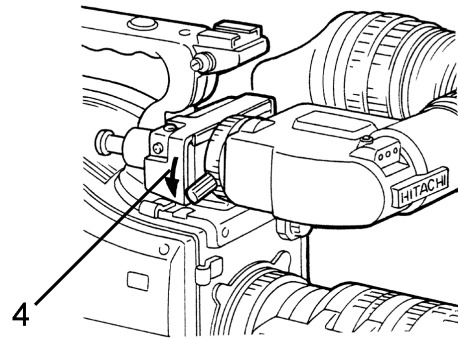
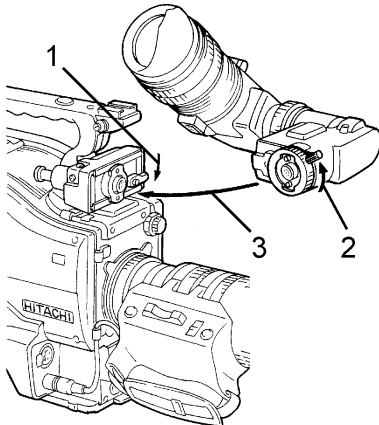

 **CAUTION**

Connect the viewfinder correctly and securely to the viewfinder connector.

Viewfinder adjustment

Position adjustment

1. Turn the lock lever in the arrow direction to loosen the horizontal lock.
2. Turn the lock screw in the arrow direction to loosen the front to rear lock.
3. Adjust the viewfinder left to right and front to rear positions for comfortable viewing.
4. Tighten the lock screw firmly.
5. Tighten the lock lever securely.

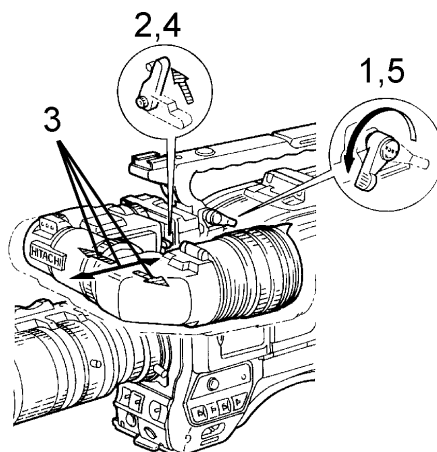

Eyepiece angle adjustment

1. Turn and loosen the securing ring.
2. Adjust the eyepiece vertical angle for comfortable viewing.
3. Firmly tighten the securing ring.

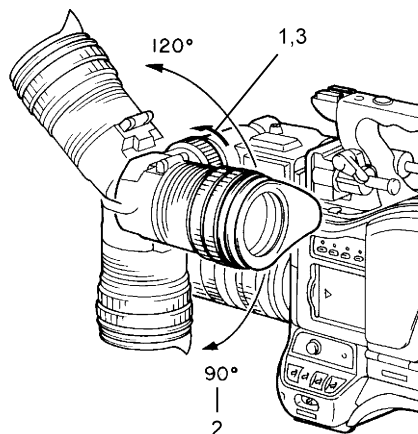

Viewfinder adjustment

Visibility adjustment

The focus can be fine adjusted to individual preference.

1. Adjust the camera focus.
2. Turn the visibility ring to adjust the focus of the viewfinder image.

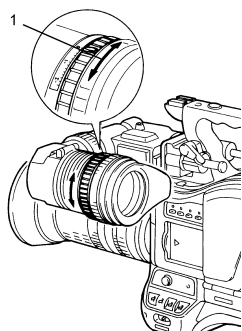

Press the Flip-up button and raise the eyecup.

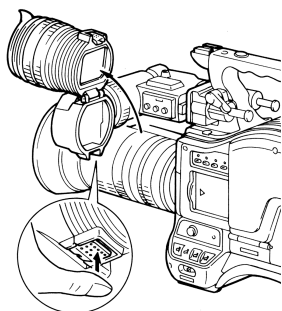

Note:

Transporting the camera

Stand the viewfinder vertically as shown in the figure for ease of carrying about.

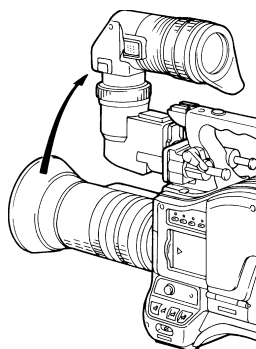

Screen adjustments

As required, adjust the brightness, contrast and peaking controls.

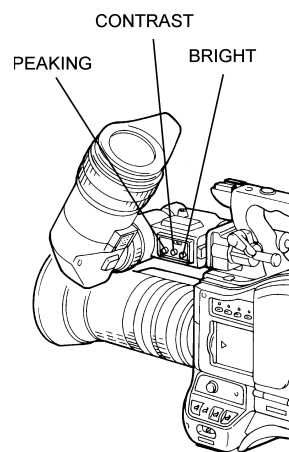

! WARNING

When the hood is raised, do not look at the sun or other bright light through and eyepiece lens. There is danger of eye damage.

When the hood is raised, do not place the camera where sunlight can pass through the eyepiece lens.

There is risk of damage to the camera and peripheral equipment, as well as a hazard of fire.

- ③ Do not place with the viewfinder pointed toward the sun. Sunlight can be focused by the eyepiece lens and damage the viewfinder interior.

Iris adjustment

Auto, manual and instant auto are selectable. Instant auto functions during manual operation to adjust the iris automatically while the button is pressed.

1. Automatic

Set the lens Iris switch to A. The iris is adjusted automatically to accommodate camera video signal changes.

2. Manual

Set the switch to M. The iris is adjusted by manually turning the iris ring.

3. Instant automatic

With the Iris switch at M, pressing the button instantly and automatically adjusts the iris.

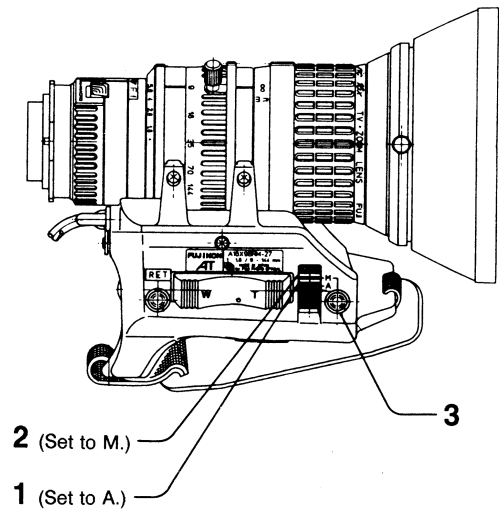

< Notes >

1 . Set the iris response (peak/average) from the Function 1 menu screen.

2 . While the menu screen is not displayed, fine adjust the auto iris by pressing the buttons.

The adjustment range using the buttons is indicated below.

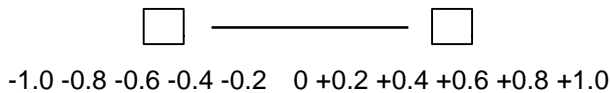

Closed about 1 F stop.

Opened about 1 F stop.

The adjustment can be used if portions of interest in the scene are too dark or too light.

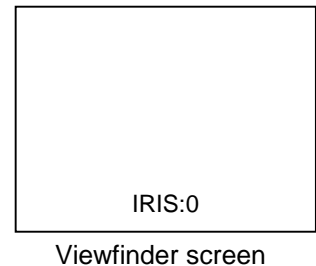

3 . Zebra pattern

When set to on, a zebra pattern appears on the viewfinder screen. The pattern can be used as a reference for manual iris adjustment.

Zoom and macro operation

Zoom operation

Zoom operation can be set for motorized or manual.

1. Motorized zoom
Set the zoom switch to S (servo) and operate the T-W switch. Press W for wide angle and T for telephoto. Press strongly for fast and gently for slow operation.
2. Manual zoom
Set the zoom switch to M (manual) and manually operate the zoom lever.

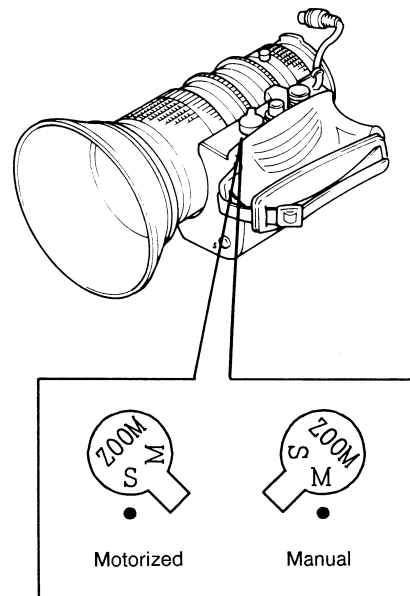

Macro operation

Use this function when the camera subject is closer than 1.1 meters from the lens.

1. Approach the camera subject for the required size image.
2. Set the focus ring to infinity (∞).
3. Set the zoom switch to M.
4. Set the macro ring to macro and fine adjust the focus with the zoom lever.

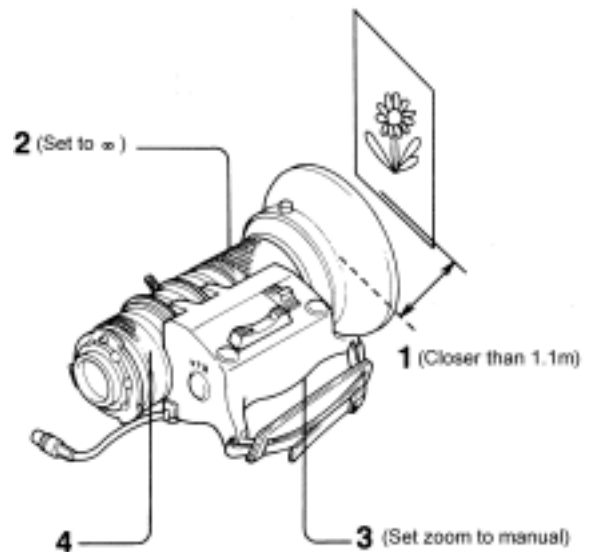

(Note)

Focus ring setting other than ∞ can darken the picture edges.

Optical filter selection

The correct optical filter according to the scene light source needs to be selected in order to obtain correct white balance. Set the CC/ND filter knob as follows.

No	Filter	Light source
1	3,200K	Studio (tungsten or halogen) Sunrise, sunset
2	5,600K+1/16ND	Outdoors clear sky
3	5,600K	Fluorescent lighting Outdoor cloudy or rainy
4	5,600K+1/64ND	Outdoors clear sky

Video gain selection

The gain can be raised to enable images in locations with inadequate lighting. Notice that noise increases as the gain is raised.

1. The viewfinder image darkens when lighting is insufficient. If the lens is auto iris, the iris opens completely. The iris setting can be checked from the viewfinder screen.
2. When the gain switch is set to M or H, an exclamation point (!) appears in the viewfinder to advise of high gain mode.

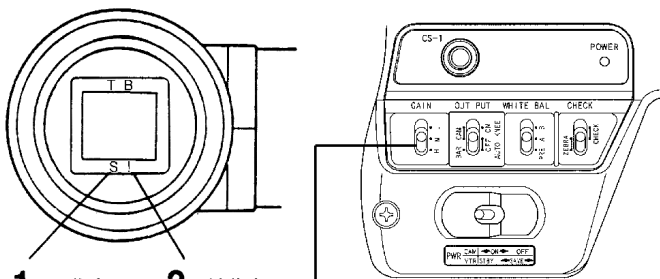
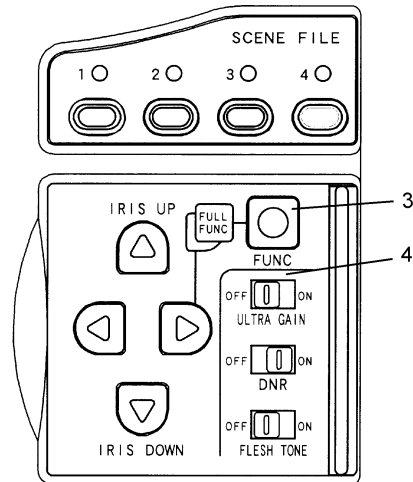

- L: standard (normal) gain (0, -3dB)
- M: (6, 9, 12dB)
- H: (12, 18, 24dB)

3. Gain values at L, M and H switch positions are set at the Function 1 page.

FUNCTION 1	SCENE 1
CONTRAST	:OFF
AUTO IRIS	:AVERAGE
GAIN LOW	:0dB
MID	:9dB
HIGH	:18dB
DTL	:->
MASKING	:PRESET
GAMMA	:PRESET
INITIALIZE	

GAIN switch	Gain value
L(LOW)	-3dB , 0dB
M(MID)	6dB, 9dB, 12dB
H(HIGH)	12dB, 18dB, 24dB

4. ULTRA GAIN

When the gain setting is above +12 dB, set the Ultra Gain switch to on to increase the sensitivity about 12 dB further. Notice this reduces the horizontal resolution by about half. Normally set the switch to off.

White and black balance adjustment

White balance adjustment

White balance is best adjusted in the sequence AWB (auto white balance), ABB (auto black balance), then again AWB.

Readjustment is normally not required even at power off/on.

Be sure to adjust the white balance after changes in the lighting conditions.

White and black balance adjustment progress can be observed from the viewfinder screen.

< Note >

The white and black balance cannot be adjusted while the setting menu is displayed on the viewfinder screen. Be sure to exit the setting menu before these adjustments.

1. Set the switches indicated in the figure.

Select a Scene File from 1 to 4. Gain and White Balance switch settings are indicated on the viewfinder screen (when VF Display menu is on).

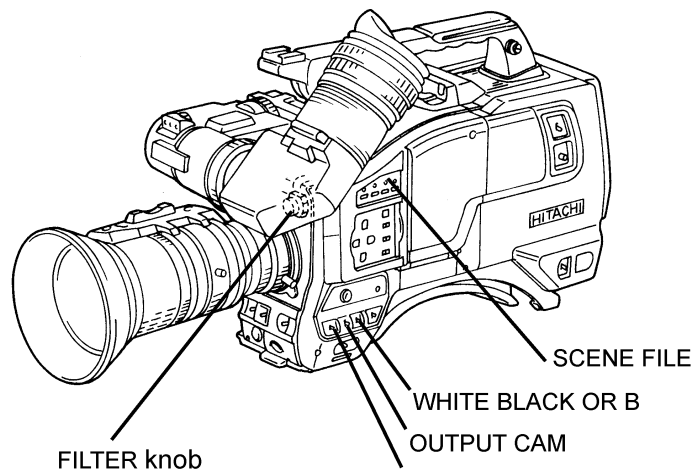

Set GAIN to as small a gain value as possible

2. Set the Filter knob according to lighting conditions.

See Optical filter selection. When changed, the new setting is indicated in the viewfinder for about 3 seconds.

3. Place a white pattern at a location subject to the same lighting conditions as the scene. Use the zoom so that the screen is white. A white object (e.g., cloth, wall) placed near the scene of interest can be used provided the size is adequate (see figure).

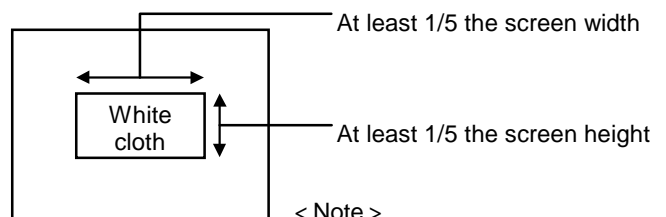

< Note >

Use care a high luminosity light source, such as a spotlight, does not enter the screen area.

White and black balance adjustment

4. Adjust the lens iris.
5. Set the White BAL switch to A or B, then set the Auto W/B BAL switch to AWB. The switch returns to center and white balance is adjusted automatically.

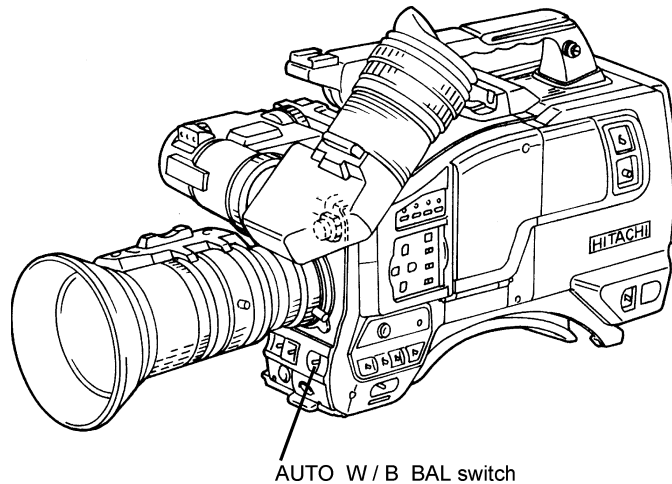

6. During adjustment, the following messages appear on the viewfinder screen.
7. Adjustment is completed in about 1 second, after which the adjustment value is automatically stored in the selected Scene File memory (A or B).

AUTO WHITE :

Adjustment in progress

AUTO WHITE : OK
FILTER: 3200K
C. TEMP: 3500K

Adjustment complete

Filter position and
illumination color
temperature.

< Note >

"Hunting" can occur if an auto iris type zoom lens is used. Adjust the lens iris gain (see lens operating instructions).

(Note 1) Hunting: Undesirable oscillation of an automatic control system, wherein the controlled variable swings on both sides of its desired value. [Dictionary of Scientific and Technical Terms, McGraw-Hill]

White and black balance adjustment

Auto white balance error messages

If auto white balance adjustment fails, the following error messages appear on the viewfinder screen for about 6 seconds.

Message	Cause	Correction
AUTO WHITE : NG CHANGE TO CAM TRY AGAIN	Output switch set to BAR.	Change switch setting to CAM and readjust.
AUTO WHITE : NG CHANGE WHITE BAL TO A/B TRY AGAIN	White BAL switch at PRE, or Full Auto is on (local mode).	Set White BAL switch to A or B, or Full Auto to off, then readjust.
AUTO WHITE : NG CHANGE WHITE BAL TO MEM TRY AGAIN	White BAL switch not at MEM (remote mode).	Set switch to MEM and readjust.
AUTO WHITE : NG LOW LIGHT TRY AGAIN	Lighting insufficient for adjustment.	Increase the lighting or set the Gain switch to M or H. If manual iris lens, adjust the lens. Then repeat white balance adjustment.
AUTO WHITE : NG LEVEL HIGH TRY AGAIN	Excessive lighting for adjustment.	Set Gain switch to a lower position. If manual iris lens, adjust the lens. Then repeat white balance adjustment.
AUTO WHITE : NG C.TEMP HIGH CHANGE FILTER TRY AGAIN	Color temperature too high for adjustment.	Change optical filter and readjust.
AUTO WHITE : NG C.TEMP LOW CHANGE FILTER TRY AGAIN	Color temperature too low for adjustment.	
AUTO WHITE : TALLY ON EXECUTE?	Tally lamp lighted.	While lighted, again set the Auto W/B BAL switch to AWB and begin adjustment.

When the above error messages appear, correct the settings and repeat white balance adjustment.

White balance memory

The adjustment values for each folder can be automatically stored in the respective memory (A or B) according to the White BAL switch setting. The total of 4 folders allows storing 8 adjustment values.

White and black balance adjustment

Black balance adjustment

Black balance requires adjustment in the following situations.

- Equipment being used for the first time
- Equipment idle for an extended period
- Large change of ambient temperature
- Gamma setting changed

Auto black balance adjustment

1. Set the switches as indicated in the figure.
2. Set the Auto W/B BAL switch to ABB and release the switch.

The switch returns to center for adjustment.

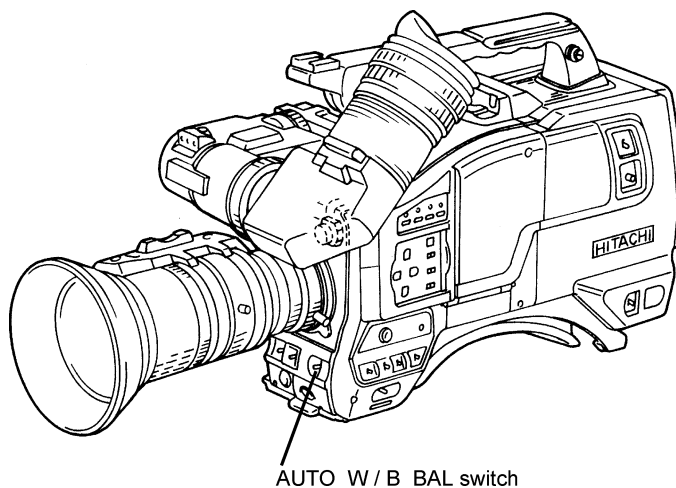

Displays the FILTER position and the color temperature of the lighting.

3. The viewfinder displays the following messages during adjustment.
The lens iris is automatically closed.
4. Adjustment is completed in several seconds and automatically stored in memory.

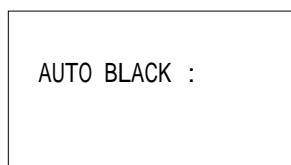

Adjustment in progress

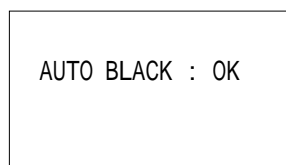

Adjustment completed

White and black balance adjustment

< Note >

Observe that the lens connector is engaged and the iris is closed.

The iris closes automatically to block the light during black balance adjustment.

During black balance adjustment, the gain circuit is switched automatically.

Although flicker or noise may appear on the viewfinder screen, these are not malfunctions.

White and black balance cannot be adjusted while the setting menu appears on the viewfinder screen. Be sure to first close the menu.

Auto black balance error messages

If auto black balance adjustment fails, the following error messages appear on the viewfinder screen for about 6 seconds.

Message	Cause	Correction
AUTO BLACK : NG CHANGE TO CAM TRY AGAIN	Output switch at BAR.	Change switch to CAM.
AUTO BLACK : NG IRIS NOT CLOSE TRY AGAIN	Iris is not closed.	See Note 1.
AUTO BLACK : TALLY ON EXECUTE?	Tally lamp lighted.	While lighted, again set the Auto W/B BAL switch to ABB and begin adjustment.
AUTO BLACK : NG ??? TRY AGAIN	Range exceeded, cannot adjust.	See Note 2.

(Notes)

- 1.The lens iris is automatically closed during black balance adjustment. If the iris control is manual, open the iris after adjustment.
- 2.Check lens connection. If ok, fault is in lens or camera. Consult service.

Electronic shutter setting

Shutter modes

The selectable electronic shutter modes and speeds are as follows.

Mode	Shutter speeds	Applications
Standard	1/60, 1/250, 1/500, 1/1000 and 1/2000 second	Clear images of quickly moving objects
LOCK SCAN (Lockscan)	1/50.14 to 1/2000 second (1H steps)	Reduce horizontal streaking in images of computer monitor
CC FRM (CC frame)		Increased vertical resolution

< Note >

Camera sensitivity declines as shutter speed increases.

An auto iris lens iris opens at increased shutter speed, while the depth of focus decreases.

Shutter mode and speed settings

1. Shift the Shutter switch from ON to SEL to change the shutter speed. The viewfinder screen indicates speed change and new shutter speed.

Example: 1/100, CCFRM

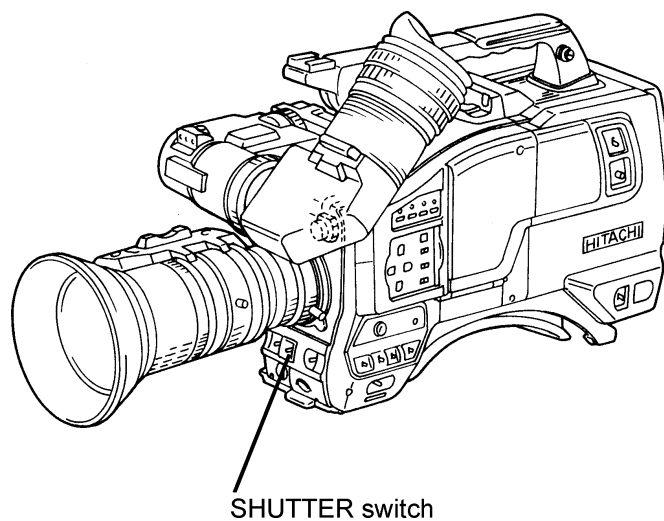

Electronic shutter setting

2. The mode and speed change sequence is indicated below.

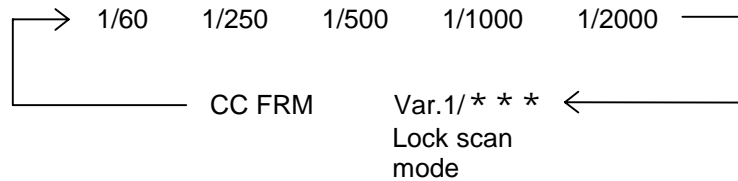

Lock scan mode setting

The lock scan mode avoids flicker in scenes showing a computer monitor screen.

1. Set the Shutter switch to SEL to produce the lock scan mode (viewfinder screen indicated in figure).
2. While Var.1/*** is indicated (about 6 seconds) set the shutter speed with the

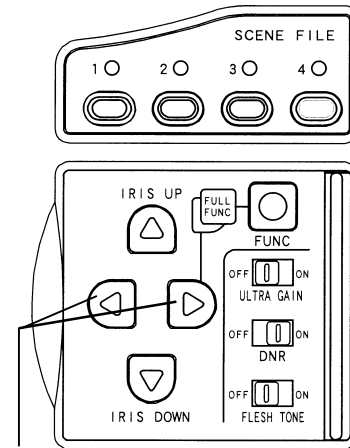
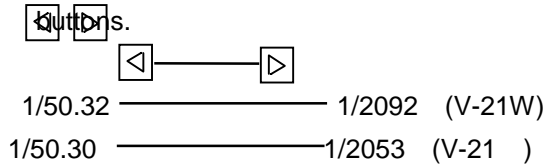

Shutter speed buttons during lock scan mode.

3. The image of a computer screen having a different scanning frequency includes a light or dark bar rolling up or down through the image. Adjust the buttons to minimize the bar.



(Note) Flicker cannot be corrected when the display screen scanning frequency is below 50.30 Hz.

CC frame mode

Increases vertical resolution, but sensitivity is reduced 1 F stop.

Operation with RU-Z1, RC-Z1/RC-Z11

1. Press the Shutter button to select the shutter mode in the following sequence.

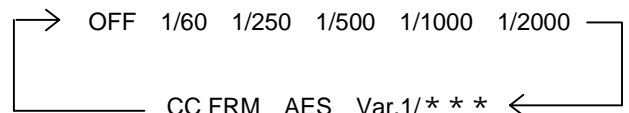

2. In the lock scan mode, the shutter speed can be set with the up/down buttons in the same manner as the camera.

Scene file

When taking scenes having different conditions, the settings need to be optimized for each scene. The scene file function enables setting the conditions for each scene beforehand and storing them in memory for instant recall at the required time. The 4 scene files can be used for storing 4 sets of scene conditions.

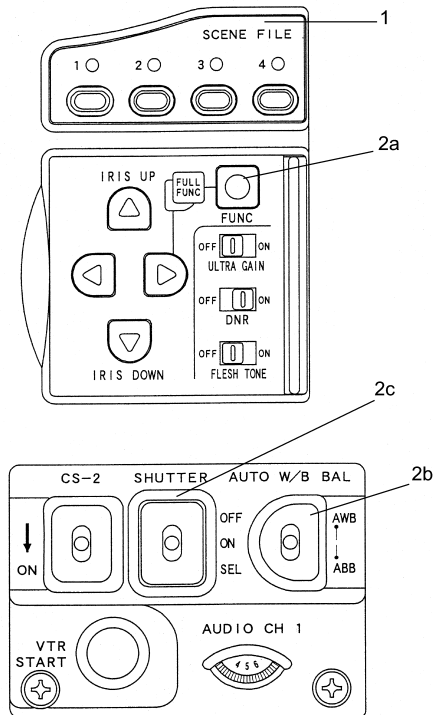

File storage items

Type	Item	Details
2a	CONTRAST	OFF, NORM, HIGH
	AUTO IRIS	AVERAGE, PEAK
	GAIN LOW	-3,0dB
	GAIN MID	+6,+9,+12dB
	GAIN HIGH	+12,+18,+24dB
	MASKING	OFF, PRESET, MEMORY
	GAMMA	OFF, PRESET, MEMORY
	DTL LEVEL	OFF,-128,...+127
	DTL FREQ	SOFT, STANDARD, SHARP
	FLESH TONE GAIN	-128,...+127
FLESH TONE PHASE	-128,...+127	
FLESH TONE WIDTH	-128,...+127	
2b	White balance data (each filter)	(Remote mode)
2c	SHUTTER SELECT	1/100,1/250,... Var, AES, CC FRM

Setting steps

1. Select the file number with the Scene File switch (adjust camera to the status previously stored in the memory).
2. Set the file storage items (if changing the memory contents).
 - a . Set the Function 1 page items from the setting menu. (See page 45.)
 - b . Operate auto white balance and store the adjustment in memory (one memory is provided for each of the 4 filters). (See page 39.)
 - c . Set the shutter and store the setting in memory. (See page 41.)

```

FUNCTION 1  SCENE 1
CONTRAST   :OFF
AUTO IRIS  :AVERAGE
GAIN LOW   :0dB
           MID   :9dB
           HIGH  :18dB
DTL        :->
MASKING    :PRESET
GAMMA      :PRESET
INITIALIZE
    
```

```

DTL        SCENE 1
DTL LEVEL  :0
DTL FREQ   :STANDARD
FLESH TONE
LEVEL      :-128
AUTO SETUP:
PHASE      :97
WIDTH      :0
    
```

Note) Data are stored in the selected file simultaneously with setting.

Camera ID setting

An identification (ID) designation for the camera can be assigned by using the ID SET page of the setting menu.

ID No. : A 3 place alphanumeric code assigned to each camera. Convenient when controlling multiple cameras from a single personal computer. A specific camera can be accessed from the computer by entering its ID number. ID number is not displayed in the color bar.

ID DISP : An up to 14 place alphanumeric message displayed at the bottom right of the screen during camera color bar output. Can be used to indicate title or other information.

< Note >

The camera ID is not indicated at Video Out even during the color bar while the setting menu is displayed.

Setting steps

1. Set the Output/Auto Knee switch to Bar and press the Function button. The Bar Function page appears in the viewfinder.
2. Press the button to position the cursor to ID SET, then press the button to open the ID SET page.

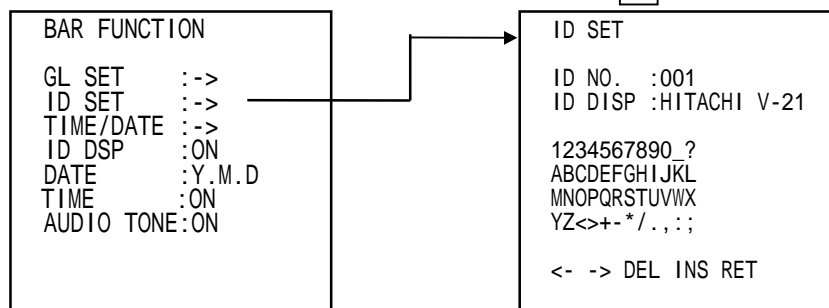

While the cursor is at the ID SET line, press the button to begin setting from ID No. 1 (setting position flashes).

Select the desired character with the buttons (character flashes).

Press the FUNC button to enter the selected character (character cursor shifts place).

Repeat the above steps and to enter the ID No. and ID DISP characters.

Set the cursor to the final line and press FUNC for special functions.

: Shift the character cursor 1 place to the left.

: Shift the character cursor 1 place to the right.

del : Delete the character at the cursor position and close the space

ins : Insert a space at the cursor position and adjust the remainder of the line.

ret : Shift cursor to the ID SET title line. Afterwards, press the FUNC button to end the function mode.

Notes

To set the ID when using the remote mode, set the Control switch of the remote operation unit to off, then set the ID with the camera controls.

Display on/off

ID display on/off can be selected at the Bar Function menu ID DISP item.

Genlock

The camera can be operated from external synchronization. The mode is automatically switched from internal to external sync when an external sync signal is supplied.

Setting

1. Set the Output/Auto Knee switch to Bar and press the Function button to display the Bar Function page in the viewfinder.
2. Press the button to position the cursor to GL SET, then press the button to show the GL SET page.

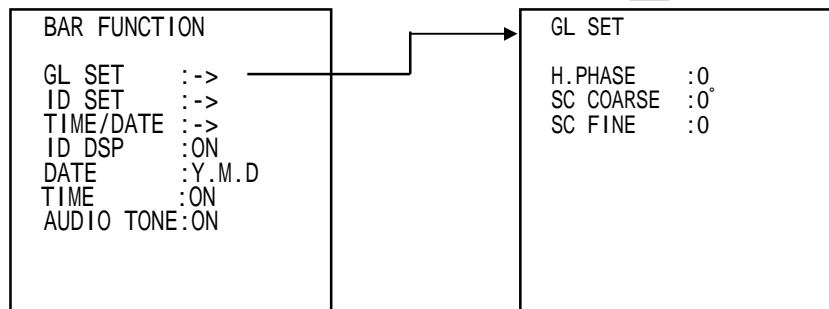

3. Adjust the horizontal phase with H PHASE and the subcarrier phase with SC COARSE and SC FINE.

Connection example

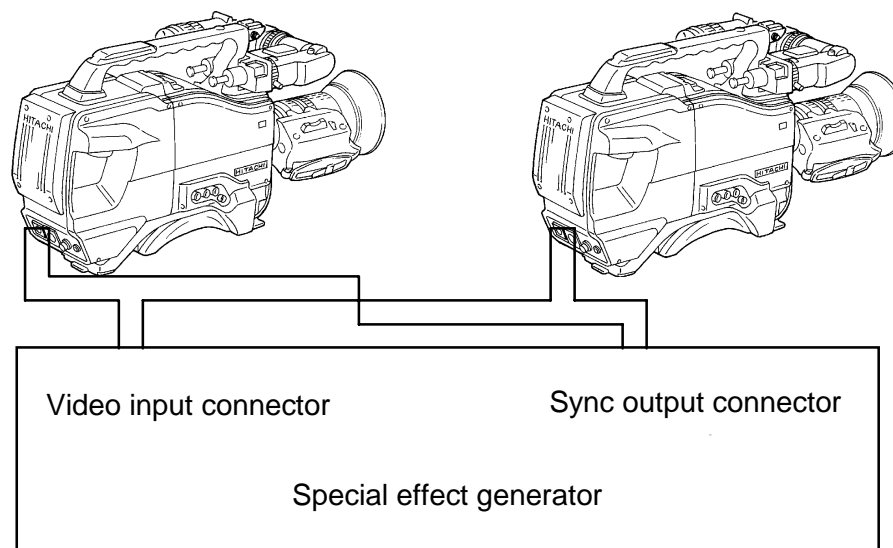

< Note >

Genlock

When two or more cameras and other equipment, such as a special effect amplifier, are connected into a system, the horizontal sync and subcarrier phase of all equipment must be aligned. Genlock applies a reference signal to the cameras to synchronize operation.

Setup card

A separately sold setup card can be used for storing the setting menu data. The data can then be used to quickly restore the proper setup.

A small size general purpose memory card (Compact Flash 2M) can be used as the setup card.

Handling

The setup card can be inserted and removed regardless of power on or off. However, avoid inserting or removing while recording is in progress, since operating error can occur.

Inserting

Position the logo side upward, insert the setup card and close the cover.

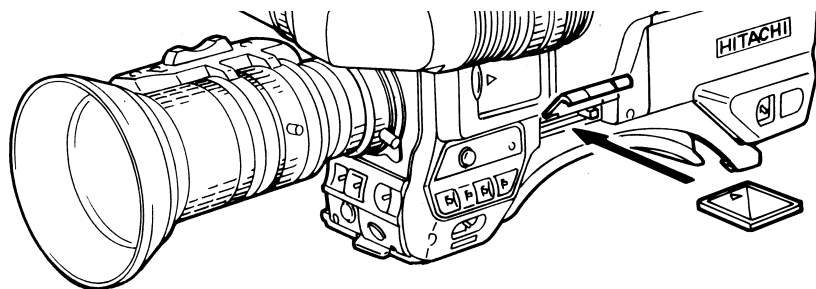

< Note >

Observe the logo is face up and label is correctly oriented when inserting the card. If difficult to insert, the card is probably upside down or backwards. Carefully check the card positioning when inserting.

Removal

Open the cover by raising the bottom edge and press the button to remove the setup card.

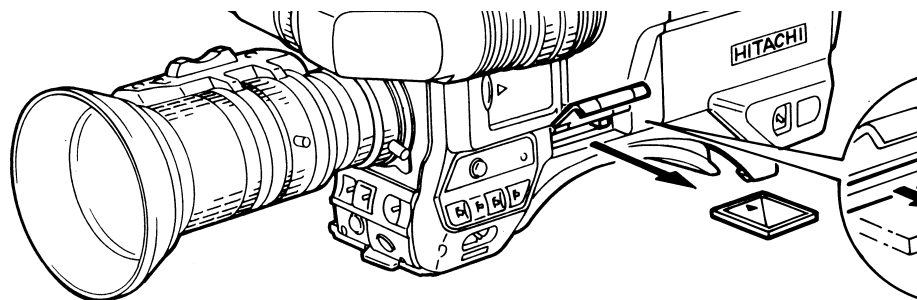

< Note >

Avoid touching the terminals at the leading edge of card.

Use and storage

Avoid the following when using and storing the card.

- High temperature and humidity
- Water drops
- Electric fields

Setup card

Setup card data operation

The Memory Card page of the setting menu is used for storing and retrieving setup card data.

< Note >

The Memory Card page cannot be used during camera control panel operation.

Saving data to card

1. Insert the setup card and press the Function button.
2. The following Setup Card page is displayed.

```
SETUP CARD

FILE NO DATE    TIME
  1  97.01.01 12:00
  2  97.06.01 12:00
  3  97.02.22 12:00
  4  97.03.01 12:00

LOAD FILE->PUSH ▷(RIGHT)
SAVE FILE->PUSH ◀◀(LEFT)
FORMAT->PUSH CHECK+▷
```

3. Shift the cursor to the desired File No. with the buttons.
4. Press the button to display the following message.

```
SETUP CARD

FILE NO DATE    TIME
  1  97.01.01 12:00
  2  97.06.01 12:00
  3  97.02.22 12:00
  4  97.03.01 12:00

SAVE FILE?
YES  ->PUSH ◀(LEFT)
CANCEL->PUSH △(UP)
```

5. If the File No. is correct, press the button for Yes. If incorrect, press the button for Cancel, then set the correct File No. The following message is indicated at the

completion of save. Press the button to return to the Memory Card Top menu, then press the Function button to exit the menu.

```
SETUP CARD

FILE NO DATE    TIME
  1  97.01.01 12:00
  2  97.06.01 12:00
  3  97.02.22 12:00
  4  97.03.01 12:00

SAVE OK
TOP MENU->PUSH ◀(LEFT)
```

If Save Error is displayed, the data were not stored. The card could possibly be defective. After replacing the card, if Error still occurs, consult for service.

Retrieving data from card

1. Insert the setup card and press the Function button.
2. The Setup Card page is displayed.

```
SETUP CARD

FILE NO DATE    TIME
  1  97.01.01 12:00
  2  97.06.01 12:00
  3  97.02.22 12:00
  4  97.03.01 12:00

LOAD FILE->PUSH ▷(RIGHT)
SAVE FILE->PUSH ◀◀(LEFT)
FORMAT->PUSH CHECK+▷
```

3. Press the keys to position the cursor to the desired File No. for readout.
4. Press the button to display the following message.

Setup card

```
SETUP CARD
FILE NO DATE      TIME
  1  97.01.01 12:00
  2  97.06.01 12:00
  3  97.02.22 12:00
  4  97.03.01 12:00

      SAVE FILE?
YES   ->PUSH <(LEFT)
CANCEL->PUSH △(UP)
```

5. If the cursor is positioned at the correct File No., press the button for Yes. If the number is incorrect, press the button for Cancel and return to the Memory Card Top menu, then press the button. To end the menu, press the Function button once.

```
SETUP CARD
FILE NO DATE      TIME
  1  97.01.01 12:00
  2  97.06.01 12:00
  3  97.02.22 12:00
  4  97.03.01 12:00

      SAVE OK
TOP MENU->PUSH <(LEFT)
```

Formatting the card

```
SETUP CARD
FILE NO DATE      TIME
  1  97.01.01 12:00
  2  97.06.01 12:00
  3  97.02.22 12:00
  4  97.03.01 12:00

      FORMAT FILE?
YES   ->PUSH CHECK+▷
CANCEL->PUSH △(UP)
```

```
SETUP CARD
FILE NO DATE      TIME
  1  97.01.01 12:00
  2  97.06.01 12:00
  3  97.02.22 12:00
  4  97.03.01 12:00

      FORMAT OK
TOP MENU->PUSH ▷(RIGHT)
```

Data load failure

If Load Error is displayed at above step 5, data were not successfully loaded. The card may be formatted incorrectly or defective. Check and if there is no problem with the card, consult a Hitachi Denshi service representative.

Viewfinder indications

In addition to the video image, the viewfinder displays messages related to camera settings and operating status, center and safety zone markers and other information.

When set to on at the setting menu VF Display page, setting items are indicated at the top and bottom edges of the screen.

Messages regarding switch changes and adjustments are shown for about 3 seconds at the center of the screen.

CAM mode

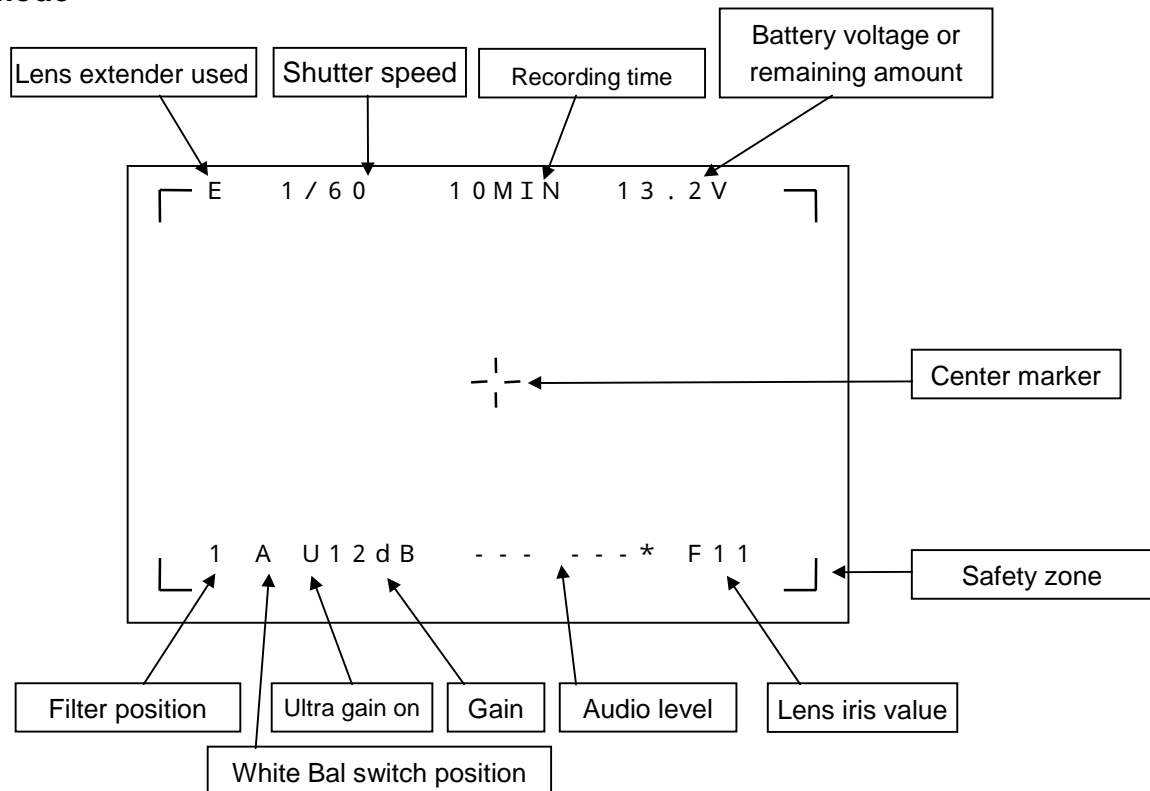

The above items are indicated only when set to on at the setting menu VF Display page.

Viewfinder indications

Display description

Item	Description	
Extender	(No indication) E W	: Extender off : Extender on : Wide setting (× 0.8) on
Shutter speed	OFF 1/60, 1/250, 1/500, 1/1000, 1/2000 1/50.14 to 1/2083 CC FRM AES	: Shutter off : Preset shutter : Lock scan mode : CC frame mode : Auto electronic shutter mode
REC Time	000 MIN to 255 MIN	Cumulative recording time. To reset, simultaneously press the ◀ ▶ buttons during REC Time display.
Battery voltage	12.0 to 13.2 V	Indicates voltage being supplied to camera
Battery remaining	MAX, 90 %, 70 %, 50 %, 30 %, 20 %, 10 %, EMP	Battery remaining amount indicated as a percentage (when using Anton/Bauer Digital Magnum series battery).
Filter position	E 1 2 3 4	: Error, filter position not set correctly : Filter 1 selected : Filter 2 selected : Filter 3 selected : Filter 4 selected
White BAL switch and full auto white balance	A B P F	: White BAL switch position A : White BAL switch position B : White BAL switch position PRE : FAW (Function 2 setting menu) on
Ultra-gain	(No indication) U	: Off : On
Gain	-3, 9, 6, 9, 12, 18, 24 dB	
Audio level	- - - - - * - - - - -	: Exceeds standard level : Standard level
Iris value	Open F2 to F22 CLS ***	: Iris open : Iris value : Iris closed : Incompatible lens (e.g., 6 pin lens)

Viewfinder indications

Check mode

Set the switch to Check and press the Check button. The CAM mode is returned about 3 seconds after releasing the button.

All items of the CAM mode are indicated at the top and bottom edges of the screen (see CAM mode description).

The center of the screen shows the DTL, Flesh tone and other switch setting states.

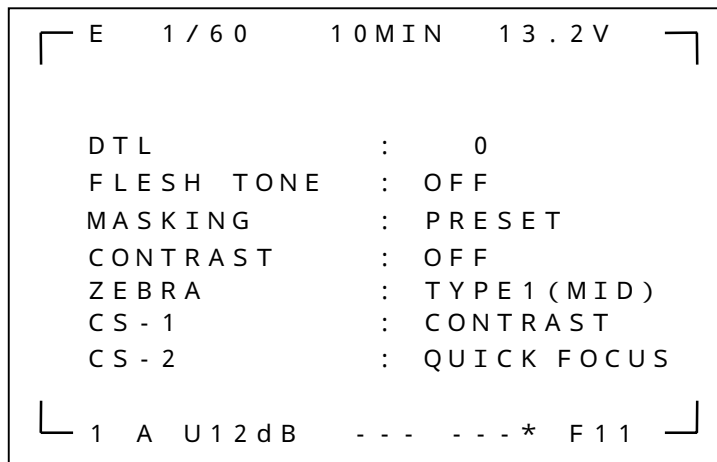

Display description

Item	Description	
DTL level	DTL	: OFF, -128.....0.....+127
Flesh tone	FLESH TONE	: ON, OFF
Masking	MASKING	: OFF, PRESET, MEMORY
Contrast	CONTRAST	: OFF, NORMAL, HIGH
Zebra type	ZEBRA	: OFF, TYPE1(LOW), TYPE1(MID), TYPE1(HIGH) TYPE2(LOW), TYPE2(MID), TYPE2(HIGH)
CS-1 switch functions	CS-1	: CONTRAST, QUICK FOCUS, FULL AUTO
CS-2 switch functions	CS-2	: CONTRAST, QUICK FOCUS, FULL AUTO

Viewfinder indications

One line indicating mode

The switch operation effect is indicated at the 2nd line from the bottom.

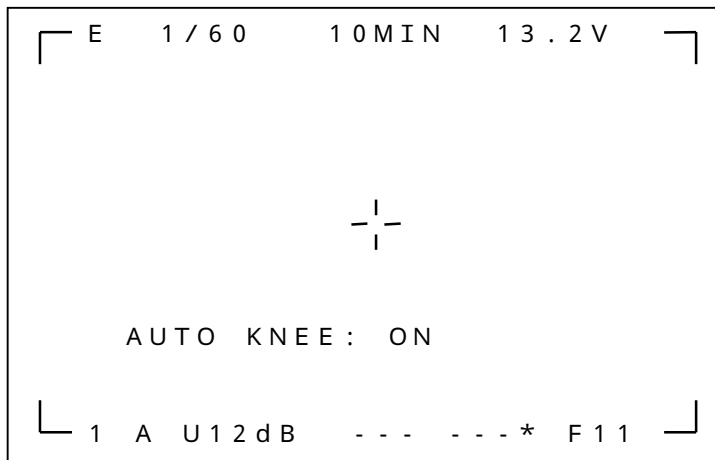

Display description

Switch	Description	
Effect (set to Zebra)	ZEBRA :	ON, OFF
ULTRA GAIN	ULTRA GAIN :	ON, OFF
FLESH TONE	FLESH TONE :	ON, OFF
DNR	DNR :	ON, OFF
CS-1, CS-2	CONTRAST :	OFF, NORMAL, HIGH
	QUICK FOCUS :	ON, OFF
	FULL AUTO :	ON, OFF
OUTPUT(AUTO KNEE)	AUTO KNEE :	ON, OFF
CC/ND FILTER	FILTER :	3200K, 5600K+1/16ND, 5600K, 5600K+1/64ND
<input type="checkbox"/> <input type="checkbox"/>	IRIS :	+1.0, +0.8, +0.4, +0.2, 0, -0.2, -0.4, -0.8, -1.0 (*1)
<input type="checkbox"/> <input type="checkbox"/> (VAR select by Shutter switch)	SHUTTER Var :	50.32 to 2092 (V-21W) (*1) 50.30 to 2053 (V-21) (*1)

*1 Iris and Shutter settings only are displayed for about 6 seconds.

Status Indication of Viewfinder Screen

BARS mode

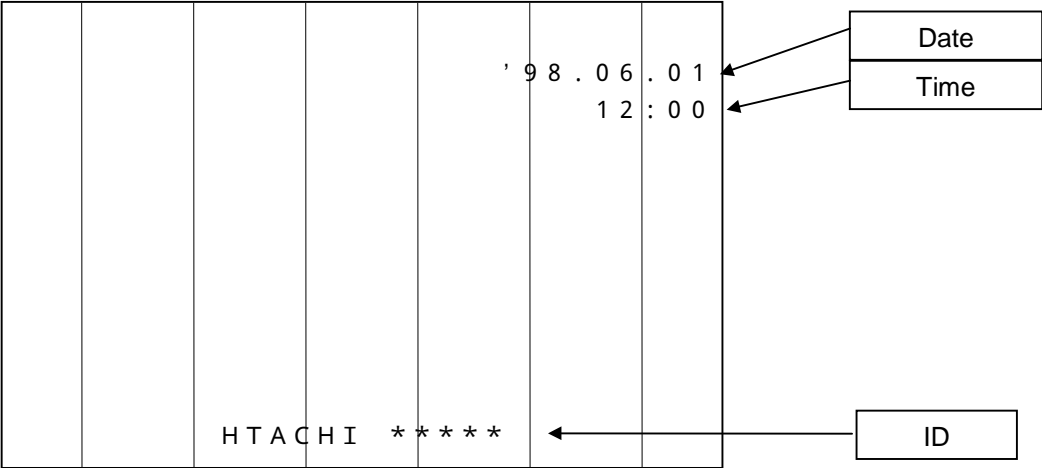

(Note) Above items are set at the Function (BAR mode) menu.

Function menu screen

Settings with Function menu

Preparation menu

Settings can be changed by using the Function menu. The principal settings are as follows.

Mode	Menu	Description
1)	CAM Setup Card	Settings when using setup card
2)	CAM Function 1	Memory items for each scene file
3)	CAM Function 2	Other memory items
4)	CAM VF Display	Viewfinder display selection
5)	BAR Bar Function	Main menu for Bar mode
6)	BAR GL Set	Genlock adjustment
7)	BAR ID Set	Identification code input
8)	BAR Time/Date	Time and date setting
9)	CAM Special Set	Use for detailed settings
	Masking	Masking adjustment
	DTL	Detail adjustment
	Gamma	Gamma adjustment
	Knee/Clip	Knee and white clip adjustments
	White Shading	White shading adjustment
	Flare	Flare adjustment
	System	System adjustment

Operation and menu screens

Operation is from the function and direction buttons.

FUNC : Function screen on/off.

◀ ▶ : • Change page when cursor is at 1st line. When a sub-menu is displayed, press **◀** return to the main menu.

When the cursor is at the 2nd line or lower, use the buttons to change the item setting or shift to a sub-menu.

At the main menu, press **▶** to display a designated sub-menu.

At the Initialize line, press both buttons simultaneously to initialize the settings.

□ □ : Shift the cursor vertically.

To display the full menu, hold the **▶** button pressed and press the Func button.

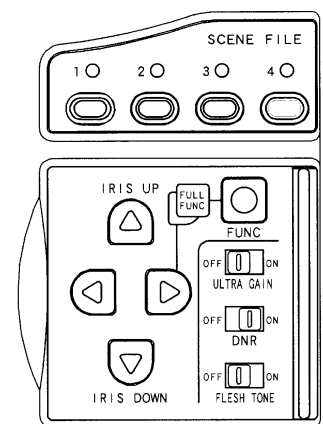

Function menu screen

CAM mode (Output switch)

Standard menu

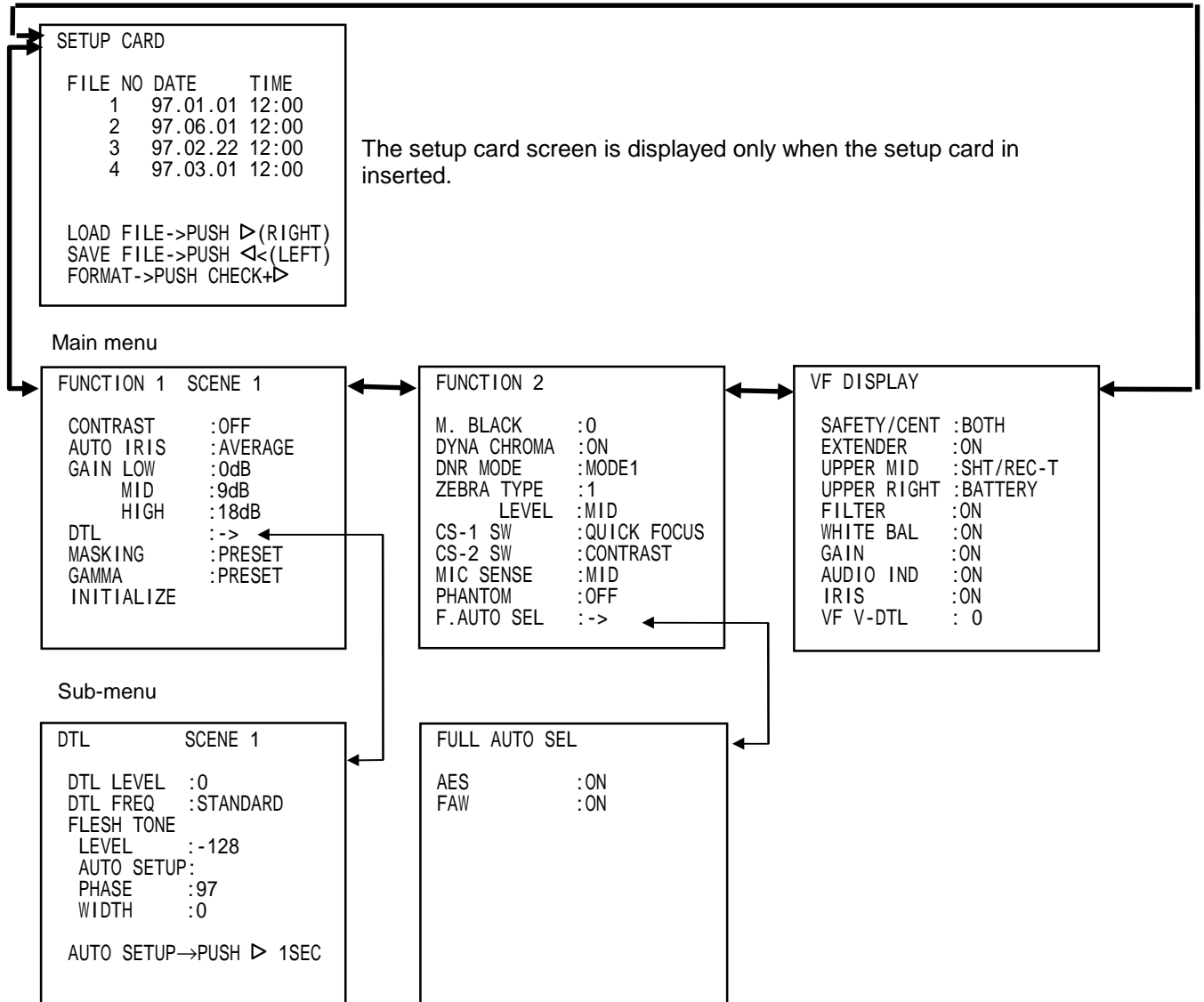

Function menu screen

CAM mode (Output switch)

Full menu

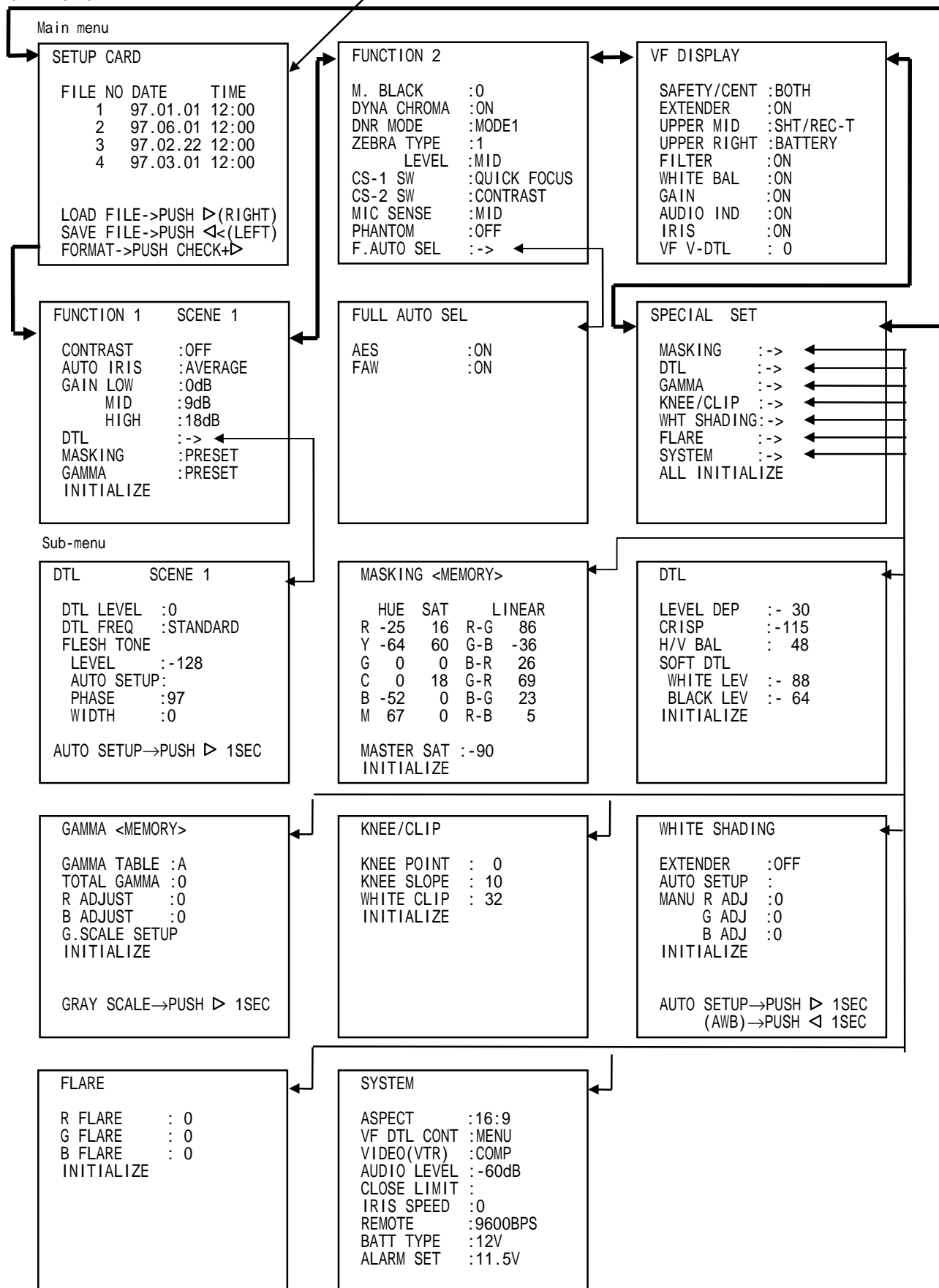

Function menu screen

Setup card menu detail

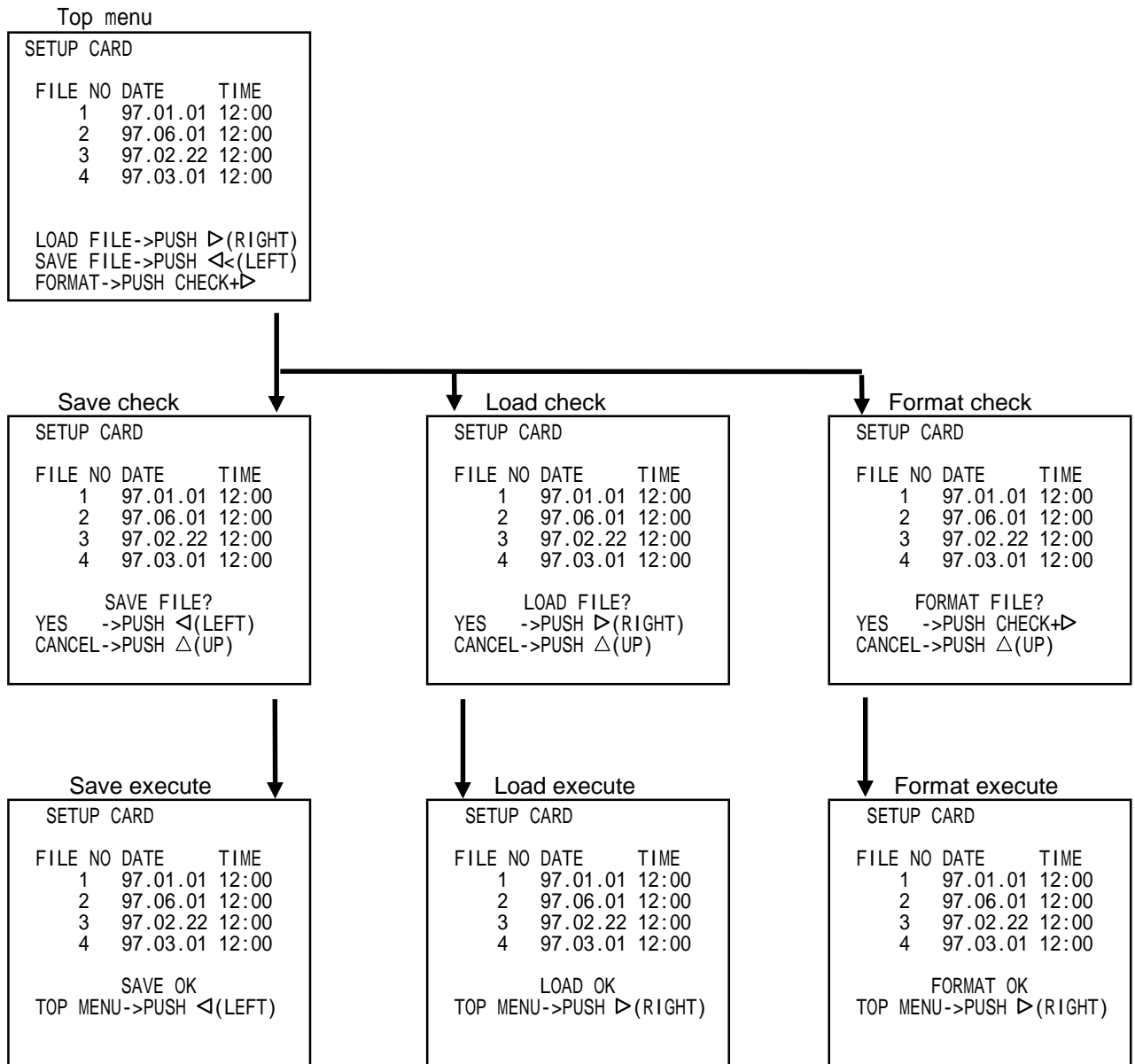

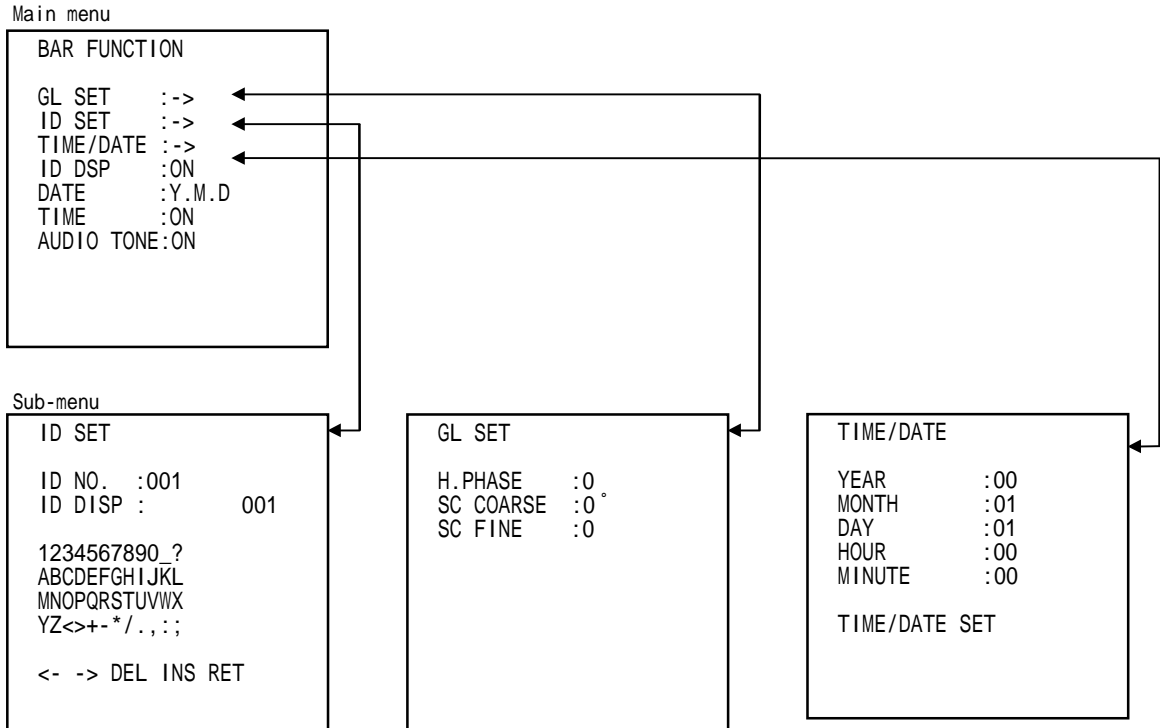

Function menu screen

BAR mode (Output switch)





Function menu screen

Function menu setting items

Rectangles indicate initialized settings (press   buttons simultaneously).

1. Function 1 (Scene 1 to 4) main menu (corresponds to scene file)

CONTRAST	<input type="checkbox"/> OFF	NORMAL	HIGH	Select Normal or High when dark scene components are difficult to see due e.g., to backlighting.	
AUTO IRIS	<input type="checkbox"/> AVERAGE	PEAK		Selects signal level detecting method for auto iris operation. AVERAGE: Easily viewed background when the scene contains bright components. PEAK: Effective for distinguishing clouds or other bright components.	
GAIN	LOW	-3dB	<input type="checkbox"/> 0dB	Select -3 dB or 0 dB (local mode only).	
	MID	6dB	<input type="checkbox"/> 9dB	12dB	Select 6, 9 or 12 dB (local mode only).
	HIGH	12dB	<input type="checkbox"/> +18dB	24dB	Select 12, 18 or 24 dB (local mode only).
DTL				Display detail sub-menu.	
MASKING	OFF	<input type="checkbox"/> PRESET	MEMORY	OFF: Color correction off. PRESET: Standard type color correction. MEMORY: Color correction set at Masking sub-menu.	
GAMMA	OFF	<input type="checkbox"/> PRESET	MEMORY	OFF: Gamma set to 1. PRESET: Standard type gamma correction MEMORY: Gamma correction set at Gamma sub-menu	
INITIALIZE				Simultaneously press the   buttons to set items of the Function 1 and DTL menus to initial values as shown in rectangles. There are 4 items per scene file and the present scene file is initialized.	

Note: Gain (LOW), (MID), (HIGH): Only in local mode

Function menu screen

1.1 DTL (Scene 1 to 4) sub-menu (corresponds to scene file)

DTL LEVEL	OFF - 128 <input type="text" value="0"/> + 127	Sets detail amount.
DTL FREQ	SOFT <input type="text" value="STANDARD"/> SHARP	SOFT: Set to low detail frequency STANDARD: Set to standard detail frequency SHARP: Set to high detail frequency
FLESHTONE	<input type="text" value="OFF"/> ON	Set to on to moderate flesh tone detail amount. Color setting is at the DTL sub-menu. (Operates only during remote control.)
LEVEL	<input type="text" value="- 128"/> 0 + 127	Adjusts flesh tone detail amount for a soft image.
AUTO SETUP		Press the <input type="text" value="▶"/> button for 1 second to detect the color phase at the center of the image and set to the optimum position.
PHASE	- 128 0 <input type="text" value="+97"/> + 127	Adjusts color phase to flesh tone. The flesh tone detection range is indicated. (The indication signal is overlapped on the video output. Use care not to operate this function while ON AIR.)
WIDTH	- 128 <input type="text" value="0"/> + 127	

2. Function 2 main menu

M.BLACK	- 128 <input type="text" value="0"/> + 127	Sets the master black value.
DYNA CHROMA	<input type="text" value="OFF"/> ON	
DNR MODE	<input type="text" value="MODE1"/> MODE2	
ZEBRA	TYPE <input type="text" value="1"/> 2	
	LEVEL LOW <input type="text" value="MID"/> HIGH	
CS-1 SW	CONTRAST <input type="text" value="QUICK FOCUS"/> FULL AUTO	
CS-2 SW	<input type="text" value="CONTRAST"/> QUICK FOCUS FULL AUTO	
MIC SENSE	LOW <input type="text" value="MID"/> HIGH	Set according to microphone sensitivity. Normally set to MID.
PHANTOM	<input type="text" value="OFF"/> ON	
F.AUTO SEL	<input type="text" value="➡"/>	

2-1 Full Auto SEL sub-menu







AES	OFF <input type="text" value="ON"/>	
FAW	OFF <input type="text" value="ON"/>	

Function menu screen



3. VF Display menu

SAFETY/CENT	OFF SAFETY CENTER <input type="checkbox"/> BOTH	
EXTENDER	OFF <input type="checkbox"/> ON	
UPPER MID	OFF ZOOM SHUTTER REC TIME <input type="checkbox"/> SHT/REC-T	
UPPER RIGHT	OFF FOCUS <input type="checkbox"/> BATTERY	
FILTER	OFF <input type="checkbox"/> ON	
WHITE BAL	OFF <input type="checkbox"/> ON	
GAIN	OFF <input type="checkbox"/> ON	
AUDIO IND	OFF <input type="checkbox"/> ON	
IRIS	OFF <input type="checkbox"/> ON	

4. Special Set menu

MASKING		Change screen to masking sub-menu.
DTL		Change screen to DTL sub-menu.
GAMMA		Change screen to gamma sub-menu.
KNEE/CLIP		Change screen to knee/clip sub-menu.
WHT SHADING		Change screen to white shading sub-menu.
FLARE		Change screen to flare sub-menu.
SYSTEM		Change screen to system sub-menu.
ALL INITIALIZE		

4-1 Masking Memory sub-menu

HUE	R: <input type="text" value="-25"/> , G: <input type="text" value="0"/> , B: <input type="text" value="-52"/> - 128 + 127 Y: <input type="text" value="-64"/> , C: <input type="text" value="0"/> , M: <input type="text" value="67"/>	6 vector independent masking. Adjust Hue and Saturation independently for red (R), yellow (Y), green (G), cyan (C), blue (B) and magenta (M).
SAT	R: <input type="text" value="16"/> , G: <input type="text" value="0"/> , B: <input type="text" value="0"/> - 128 + 127 Y: <input type="text" value="60"/> , C: <input type="text" value="18"/> , M: <input type="text" value="0"/>	
LINEAR	- 128 <input type="text" value="0"/> + 127	R-G, G-B, B-R, B-G, R-B (linear matrix) Sets linear matrix between respective colors.
MASTER SAT	- 128 <input type="text" value="-90"/> 0 + 127	
INITIALIZE		Simultaneously press the   buttons to initialize masking sub-menu items to values shown in rectangles.

Function menu screen

4-2 DTL sub-menu

LEVEL DEP	- 128	<input type="text" value="- 90"/>	0	+ 127	Dark component detail can be set in the range of -128 to +127.
CRISP	- 128	<input type="text" value="- 110"/>	0	+ 127	Average component detail can be set in the range of -128 to +127.
H/V BAL	- 128	0	<input type="text" value="+ 48"/>	+ 127	Adjust balance between horizontal and vertical detail.
SOFT DTL	WHITE LEV	- 128	<input type="text" value="- 88"/>	0	Reduce excess detail signal at strong contrast edges for a softened image. White and black direction detail signals are separately adjustable.
	BLACK LEV	- 128	<input type="text" value="- 64"/>	0	
INITIALIZE					Simultaneously press the <input type="text" value="◀"/> <input type="text" value="▶"/> buttons to initialize DTL sub-menu items to values shown in rectangles.

4-3 Gamma Memory sub-menu

GAMMA TABLE	<input type="text" value="A"/>	B	C	Selects gamma rise inclination. (Special gamma) A: Standard value B: Reduces dark component gradation C: Raises dark component gradation	
TOTAL GAMMA	- 128	<input type="text" value="0"/>	+ 127	Gamma correction can be changed from the standard setting.	
R ADJUST	- 128	<input type="text" value="0"/>	+ 127	Total, R and B gamma can be finely adjusted.	
B ADJUST	- 128	<input type="text" value="0"/>	+ 127		
G.SCALE SETUP					Position the marker on the chart and push the <input type="text" value="▶"/> button for 1 second to automatically execute the gray scale automatic setup.
INITIALIZE					Simultaneously press the <input type="text" value="◀"/> <input type="text" value="▶"/> buttons to initialize Gamma sub-menu items to values shown in rectangles.

Function menu screen

4-4 Knee/clip sub-menu

KNEE POINT	- 128	<input type="text" value="0"/>	+ 127	Sets the level where knee function begins operating.	
KNEE SLOPE	- 128	0	<input type="text" value="+10"/>	+ 127	Sets knee response slope.
WHITE CLIP	- 128	0	<input type="text" value="+32"/>	+ 127	Sets the white clip level.
INITIALIZE				Simultaneously press the <input type="button" value="◀"/> <input type="button" value="▶"/> buttons to initialize Knee/clip sub-menu items to values shown in rectangles.	

4-5 White shading sub-menu

Corrects vertical white shading due to the lens.

EXTENDER	OFF	ON	On is indicated when using a lens provided with an extender (indication only). White shading is set respectively for extender on and off.		
AUTO SETUP	Automatic white shading adjustment. Start by adjusting the green channel shading with MANU G ADJ. Next, adjust the auto white by pushing the <input type="button" value="◀"/> button for 1 second. Then, adjust the auto white by pushing the <input type="button" value="▶"/> button for 1 second.				
MANU	R ADJ	- 128	<input type="text" value="0"/>	+ 127	Use when adjusting white shading manually.
	G ADJ	- 128	<input type="text" value="0"/>	+ 127	
	B ADJ	- 128	<input type="text" value="0"/>	+ 127	
INITIALIZE				Simultaneously press the <input type="button" value="◀"/> <input type="button" value="▶"/> buttons to initialize White Shading sub-menu items to values shown in rectangles.	

4-6 Flare sub-menu

R FLARE	- 128	<input type="text" value="0"/>	+ 127	Adjust red signal flare correction.
G FLARE	- 128	<input type="text" value="0"/>	+ 127	Adjust green signal flare correction.
B FLARE	- 128	<input type="text" value="0"/>	+ 127	Adjust blue signal flare correction.
INITIALIZE				Simultaneously press the <input type="button" value="◀"/> <input type="button" value="▶"/> buttons to initialize Flare sub-menu items to values shown in rectangles.



Function menu screen

4-7 System sub-menu

ASPECT	<input type="text" value="16:9"/> 4:3	V-21W only								
VF DTL CONT	<input type="text" value="MENU"/> AUTO									
VIDEO(VTR)	COMP Y/C VBS RGB Also Auto (when inner module is connected)	Select according to connected VTR. 1.COMPONENT 2.Y/C(S-VHS) 3.VBS(U-matic) 4.R,G,B								
AUDIO LEVEL	<input type="text" value="- 60dB"/> - 20dB Also Auto (when inner module is connected)	Set the audio level to -60 or -20 dB according to the combined VTR.								
CLOSE LIMIT	Hunting can occur when using an auto iris lens under unusually bright conditions, where the iris is nearly closed. This adjustment avoids the hunting phenomenon. When AES is on, the AES operates when the light is greater than the close limit value. When the cursor is shifted to Close Limit, the lens iris is automatically set to the close limit value. When replacing the lens, set the value to F16.									
IRIS SPEED	- 128 <input type="text" value="0"/> + 127	Adjust when using a 6 pin type lens (for a 12 pin type, use adjustment provided with the lens). The auto iris response speed increases toward the + side. Adjust to where hunting does not occur.								
REMOTE	62500BPS <input type="text" value="9600BPS"/>	Select communication rate. 62500BPS: RU-Z1, RC-Z1 and RC-Z11 9600BPS : RU-Z2, RC-Z2A and RC-Z21A								
BATT TYPE	<input type="text" value="12.0V"/> 13.2V 14.4V	Select from 3 voltages according to battery type.								
ALARM SET	<table border="1"> <thead> <tr> <th>BATT TYPE</th> <th>Alarm operating voltage</th> </tr> </thead> <tbody> <tr> <td>12.0V</td> <td>10.5V, <input type="text" value="11.0V"/>, 11.6V</td> </tr> <tr> <td>13.2V</td> <td>11.7V, <input type="text" value="12.2V"/>, 12.8V</td> </tr> <tr> <td>14.4V</td> <td>12.9V, <input type="text" value="13.4V"/>, 14.0V</td> </tr> </tbody> </table>	BATT TYPE	Alarm operating voltage	12.0V	10.5V, <input type="text" value="11.0V"/> , 11.6V	13.2V	11.7V, <input type="text" value="12.2V"/> , 12.8V	14.4V	12.9V, <input type="text" value="13.4V"/> , 14.0V	Adjust voltage at which battery alarm lights.
BATT TYPE	Alarm operating voltage									
12.0V	10.5V, <input type="text" value="11.0V"/> , 11.6V									
13.2V	11.7V, <input type="text" value="12.2V"/> , 12.8V									
14.4V	12.9V, <input type="text" value="13.4V"/> , 14.0V									

Function menu screen

5. BARS Function sub-menu

GL SET		Execute GL SET sub-menu.
ID SET		Execute ID IND sub-menu.
TIME/DATE		Execute TIME/DATE sub-menu.
ID DSP	OFF <input type="checkbox"/> ON <input type="checkbox"/>	
DATE	OFF <input type="checkbox"/> Y.M.D <input type="checkbox"/> M.D.Y D.M.Y	
TIME	OFF <input type="checkbox"/> ON <input type="checkbox"/>	
AUDIO TONE	OFF <input type="checkbox"/> ON <input type="checkbox"/>	



5-1 GL SET sub-menu

H . PHASE	- 128 + 127	Adjust horizontal phase during genlock operation.
SC COARSE	0 ° 90 ° 180 ° 270 °	Adjust subcarrier coarse during genlock operation.
SC FINE	- 128 + 127	Adjust subcarrier fine during genlock operation.

5-2 ID SET sub-menu

ID No.	3 place alphanumeric code	Set camera identification number and a desired title. (See page 44.)
ID DISP	Up to 14 place alphanumeric code	

5-3 TIME/DATE sub-menu

YEAR	00 . . 99	
MONTH	01 . . 12	
DAY	01 . . 31	
HOUR	00 . . 23	
MINUTE	00 . . 59	
TIME/DATE SET		Simultaneously press the   buttons to activate the time and date setting

Studio system operation

Connection with RU-Z2/RU-Z3 system

The camera can be connected into a system comprising an RU-Z2/Z3 camera base station and RC-Z2A / Z21A/Z3 camera control panel to enable remote operation of the camera control functions. The camera and RU-Z2/RC-Z3 can be separated by up to 300 meters, while a 5-inch viewfinder can be used in place of the 1.5-inch viewfinder.

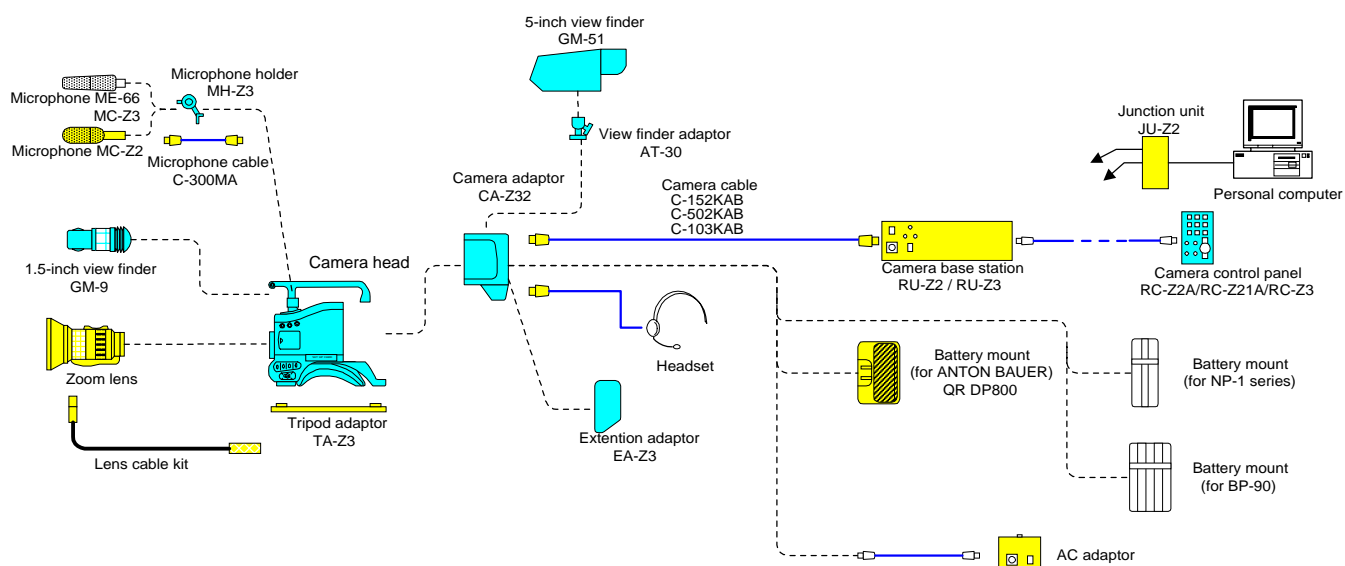

Refer to the RU-Z2/Z3 Camera Base Station and RC-Z2A/Z21A/Z3 operation manual for detailed operating instructions.

ROU adaptor unit

When connecting the RU-Z2/RU-Z3, install the RU-Z2/Z3 accessory ROU adaptor unit in CA-Z32 camera adaptor as indicated in the figure.

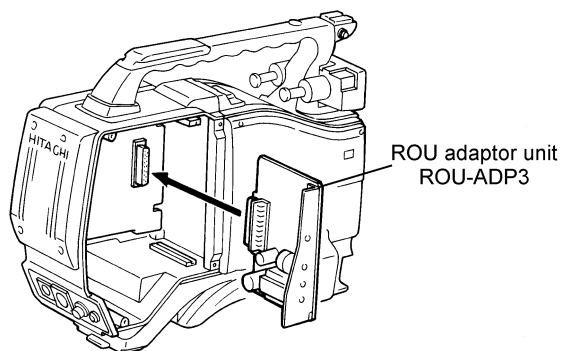

Power select switch setting

Set the power select switch to CCU / VTR.

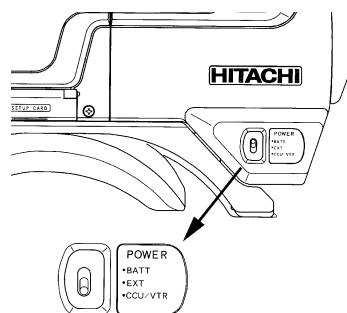

Note: The unit is not interchangeable with the ROU-ADP2 for the CA-Z31.

Studio system operation

Camera control from personal computer

The camera can be controlled by RS-232C signals from a personal computer. In this case, the JU-C20 RS-232C Level Converter or the JU-Z2 Junction Unit is required.

Since camera control software is not supplied, refer to the protocol technical data and compile a suitable program according to the computer being used.

Technical data are available regarding the software protocol for controlling the camera. Please consult a Hitachi Denshi representative.

Technical data

- 1) Remote control protocol
- 2) Remote control command list

Studio system operation

Connection with RU-Z1 system

The camera can be connected into a studio system comprising an RU-Z1 remote operation unit and RC-Z1A /Z11 camera control panel to enable remote operation of the camera control functions. The camera and RU-Z1 can be separated by up to 300 meters, while a 5-inch viewfinder.

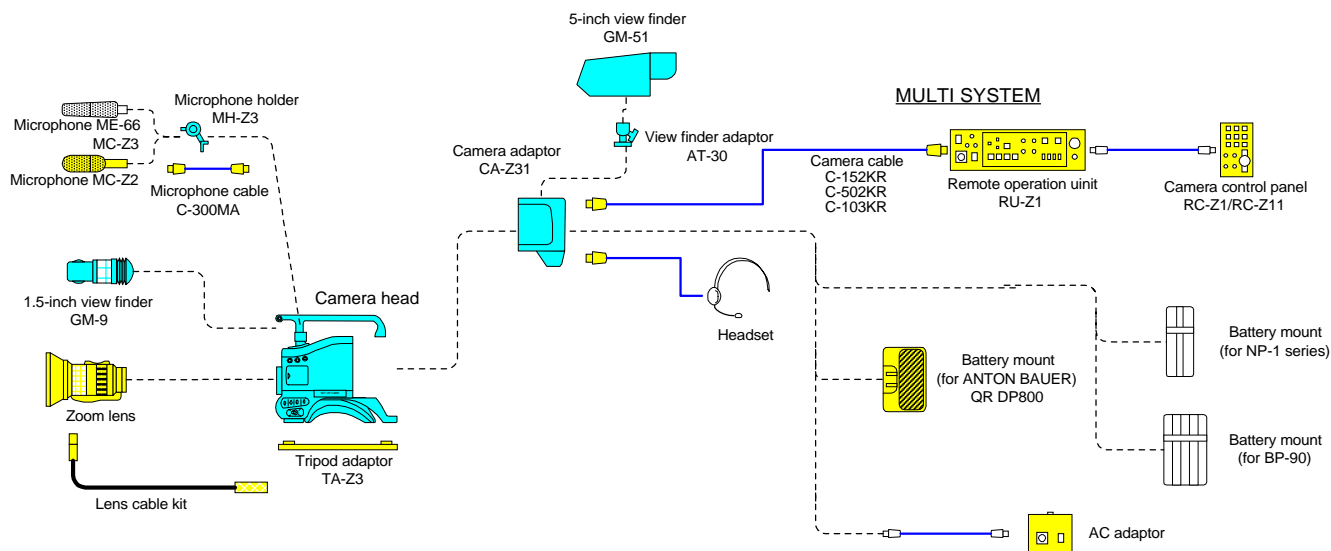

Refer to the RU-Z1 Remote Operation Unit and RC-Z1A / Z11A operation manuals for detailed operating instructions.

ROU adaptor unit

When connecting the RU-Z1, install the RU-Z1 accessory ROU adaptor unit in the CA-Z31 camera adaptor as indicated in the figure.

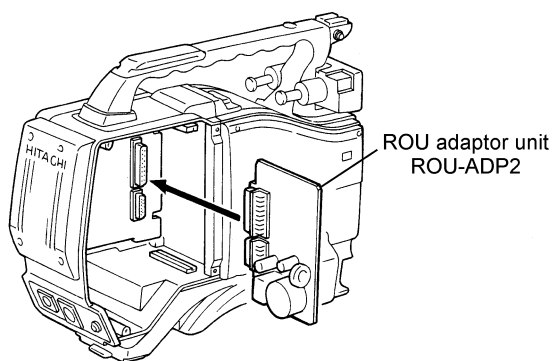

POWER select switch setting

Set the power select switch to CCU / VTR.

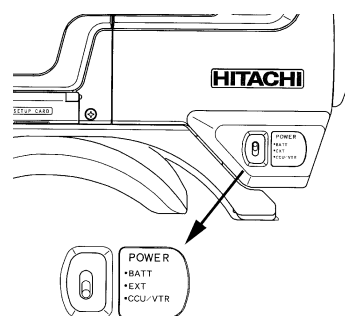

Note: The unit is not interchangeable with the ROU-ADP3 for the CA-Z32

Studio system operation

Auto setting with RU-Z3 / RU-Z2 / RU-Z1 (plug & play)s

No	System	Baud rate	Audio level	Video output	Battery type
1	RU-Z1	62.5K(* 1)	-20db(* 1)	RGB COMP100 COMP75 YC, VBS (* 2)	12.0V(* 1) (* 3)
2	RU-Z2 /RC-Z3	9600(* 1)			
	(TU-Z3 system) (COMP TRIAX)	9600(* 1)			
3	TU-Z2 inner module via IM-Z3B	9600(* 1)			
4	Self-contained inner module operation M-Z3B (Betacam)	62.5K, 9600	AUTO(* 4)	AUTO(* 4)	12.0V 13.2V 14.4V
	M-Z3P (DVCPRO)				
	IM-Z3S (BetaPRO)				
	IM-Z3J (Digital-S)				
5	Self-contained Camera adapter operation CA-Z31/32 (portable VTR)	62.5K 9600	-60dB -20dB	COMP100, COMP75, YC, VBS, RGB	

Notes:

- When RU-Z1/Z2/Z3 (RC-Z1/Z2A/Z3) remote control is off, although settings can be changed at the camera head full menu, the I initial settings are returned at resupply of power.
- When RU-Z1/Z2/Z3 (RC-Z1/Z2A/Z3) remote control is off, settings can be changed at the camera head full menu. Settings are stored as common setting values in the RU-Z1/Z2/Z3 (RC-Z1/Z2A/Z3) memory.
- With RU-Z1/Z2A, Alarm Set is fixed at 11.0 V.
- When Auto is indicated, settings are automatic at the inner module.

RU-Z2(RU-Z1)RGB connector signal output

The signals indicated in the table can be selected for output from the RU-Z2(RU-Z1)RGB connector.

- Set the RC-Z2A / Z21A/Z3(RC-Z1 / Z11) remote control switch to off. Control shifts from the RC to the camera.
- Select the SYSTEM sub-menu from the Function menu, then select the output signal at the VIDEO <VTR> item.

Note: When the RBG connector output is other than RGB, the RU-Z2 waveform monitor (WFM OUT) display does not operate correctly.

connector	Output signal			
	RGB	Component	Y / C	VBS
R	R	R-Y	C	-
G	G	Y	Y	VBS
B	B	B-Y	-	-

SYSTEM

```

VF DTL CONT : MENU
VIDEO(VTR)  : COMP100%
AUDIO LEVEL : -60dB
CLOSE LIMIT :
IRIS SPEED  : 0
REMOTE      : 9600BPS
BATT TYPE   : 12V
ALARM SET   : 11.5V
    
```

System configuration

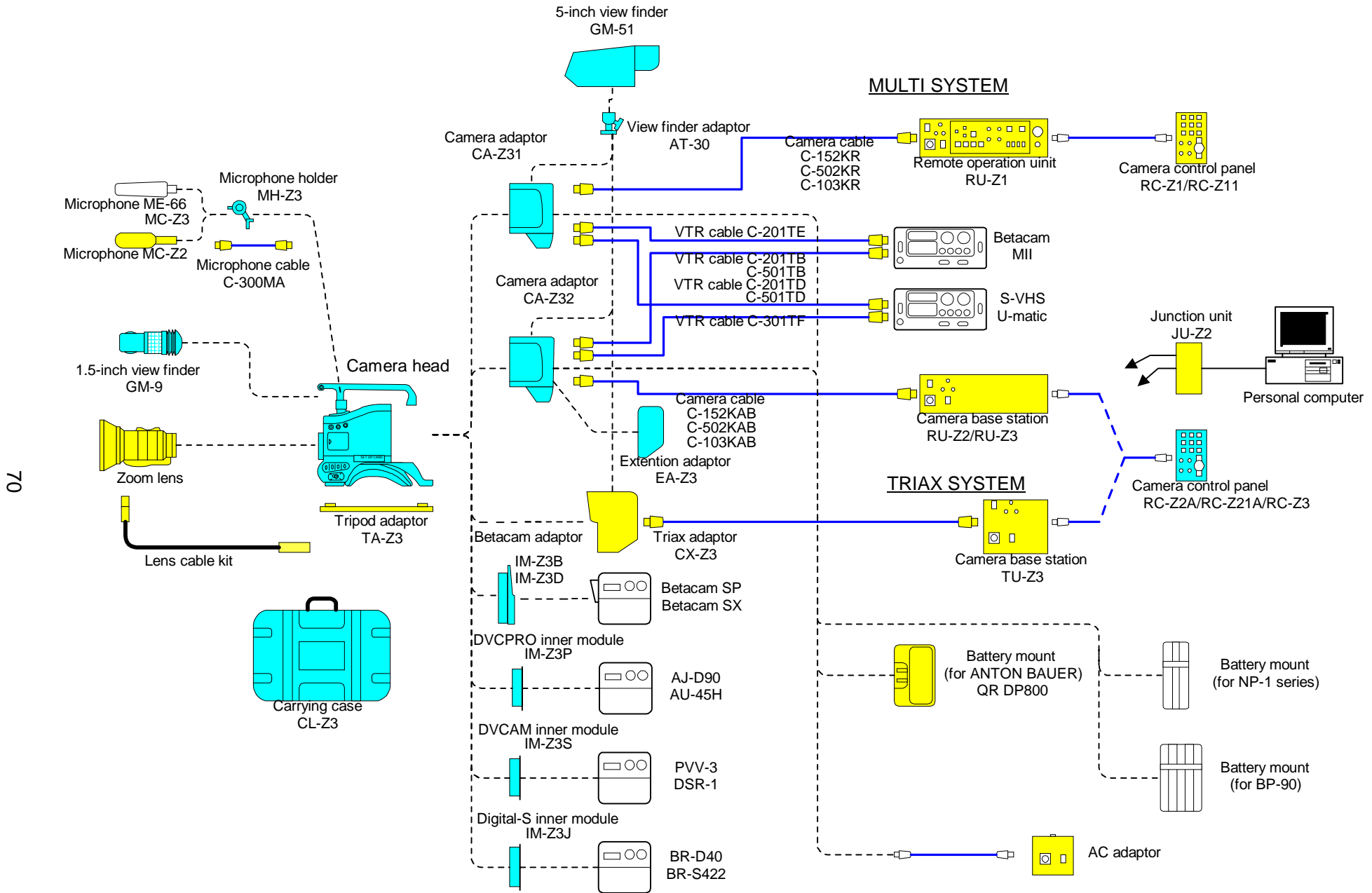

70

Service information

Connector pin diagrams

Camera

Remote (4 pin female)

Pin	Signal
1	+9V output
2	SD input
3	SD output
4	SD ground

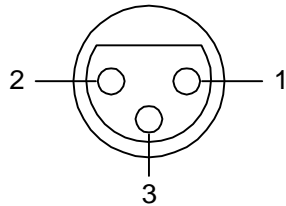
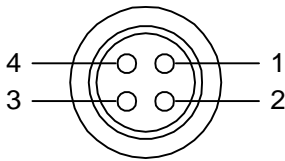

MIC IN (3 pin female)

Pin	Signal
1	MIC GND
2	MIC(H) IN
3	MIC(C) IN

LENS (12 pin female)

Pin	Signal
1	AUX SW
2	CALL TRG
3	GND
4	ENF AUTO
5	IRIS CONTROL
6	+12V
7	IRIS POSITION
8	NC
9	NC
10	NC
11	NC
12	NC

VF (8 pin male)

Pin	Signal
A	B LED(C)
B	! LED
C	VF 9V
D	+12V
E	S LED
F	VF VIDEO(Y)
G	GND
H	T LED

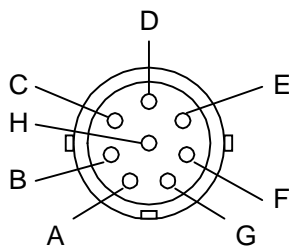
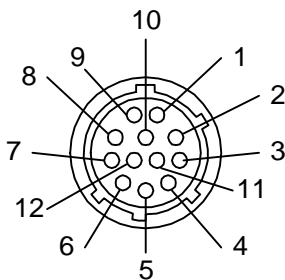

Camera adapter (CA-Z31/CA-Z32)

DC IN (4 pin male)

Pin	Signal
1	GND
2	NC
3	NC
4	+12V input

INTERCOM (5 pin male)

Pin	Signal
1	SHIELD
2	T
3	GND
4	R
5	R

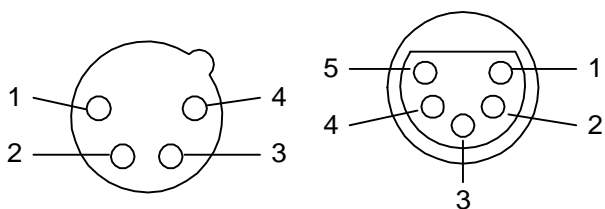

Service information

CCU/VTR (28 pin male) < CA-Z31 >

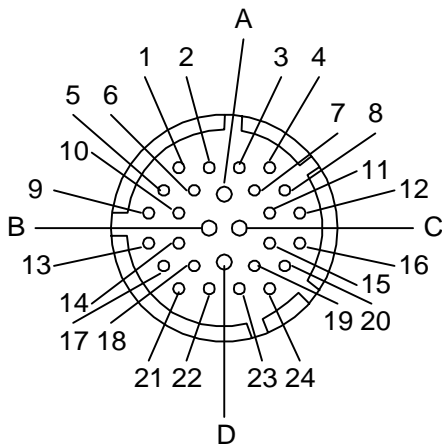

Pin	Signal	Pin	Signal
A	+12V	11	COLOR FRAME
B	+40V	12	VBS VIDEO
C	SHIELD GND	13	VTR SAVE
D	POWER GND	14	BATT ALM
1	GL GND	15	SD GND
2	GL	16	VBS GND
3	R.G.B GND	17	INCOM L1
4	R/R-Y/C	18	CALL/TRIG
5	VTR TRG	19	SYNC CHR
6	REC/TALLY	20	AUX GND
7	G/Y/VBS	21	SYNC CHR GND
8	B/B-Y	22	INCOM L2
9	AUDIO(+)	23	SD
10	AUDIO(-)	24	AUX VIDEO

CCU/VTR (26 pin male) < CA-Z32 >

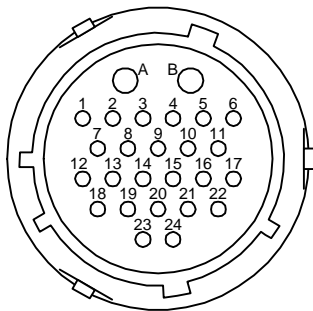

Pin	Signal	Pin	Signal
A	+150V/+12V	12	PROMPT GND
B	POWER GND	13	PROMPT VIDEO
1	VBS	14	INTER LOCK
2	VBS GND	15	INCOM2
3	G/Y/VBS GND	16	GL
4	G/Y/VBS	17	INCOM GND
5	R/R-Y/C	18	AUX VIDEO
6	R/R-Y/C GND	19	AUX GND
7	B/B-Y	20	INCOM1
8	B/B-Y GND	21	GL GND
9	MIC(H)	22	SD2
10	MIC(C)	23	SD1
11	MIC GND	24	SD GND
			VTR TRIG
			BATT ALM
			TAPE IND
			REC/TALLY
			RET V CONT
			PB VIDEO
			PB GND
			VTR SAVE/ AUDIO MON
			TAPE REMAIN
			C.F. PULSE
			VD
			C.SYNC

150 V OUT (5 pin male) < CA-Z32 >

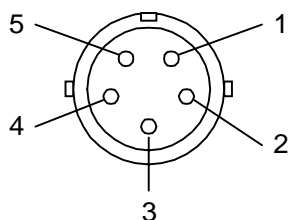

Pin	Signal
1	NC
2	RLY CONT
3	RLY CONT GND
4	+150V OUT
5	0V

SAFETY INSTRUCTIONS

Carefully read all safety messages in this manual and safety instructions on your equipment.
Follow recommended precautions and safe operating practices.

SAFETY ALERT SYMBOL



This is the "Safety Alert Symbol." This symbol is used to call your attention to items or operations that could be dangerous to you or other persons using this equipment. Read these messages and follow these instructions carefully.

It is essential that you read the instructions and safety regulations before you attempt to assemble or use this equipment.

The definitions of signal words are as follows:



WARNING: Personal danger

Warning notes indicate any condition or practice, which if not strictly observed, could result in personal injury or possible death.



CAUTION: Possible damage to equipment

Caution notes indicate any condition or practice, which if not strictly observed or remedied, could result in damage or destruction of the equipment.

NOTE

NOTE: Notes indicate an area or subject of special merit, emphasizing either the product's capabilities or common errors in operation or maintenance.



TO REDUCE THE RISK OF FIRE OR ELECTRIC SHOCK, DO NOT EXPOSE THIS COLOR CAMERA TO RAIN OR MOISTURE.

AVERTISSEMENT

Afin d'éviter tout risque d'incendie ou d'électrocution, ne pas exposer l'appareil à la pluie ou à l'humidité.

Afin d'écarter tout risque d'électrocution, garder le coffret fermé. Ne confier l'entretien de l'appareil qu'à un personnel qualifié.

VORSICHT

Um Feuergefahr und die Gefahr eines elektrischen Schlags zu vermeiden, darf das Gerät weder Regen noch Feuchtigkeit ausgesetzt werden.

Um einen elektrischen Schlag zu vermeiden, darf das Gehäuse nicht geöffnet werden. Überlassen Sie Wartungsarbeiten stets nur einem Fachmann.

Note: The model and serial numbers of your color camera are important for you to keep for your convenience and protection. These numbers appear on the nameplate located on the topframe of the color camera. Please record these numbers in the spaces provided below, and retain this manual for future reference.

Model No. _____

Serial No. _____

HITACHI DENSHI, LTD.

1, Kanda Izumi-cho Chiyoda-ku, Tokyo 101-0024, Japan
Phone: 03-5821-5311, FAX: 03-5821-5394

HITACHI DENSHI AMERICA, LTD.*

Headquarters and New York Office

150 Crossways Park Drive, Woodbury, New York 11797, U.S.A.
Phone: 516-921-7200, FAX: 516-496-3718

Chicago Office

450 East Devon Ave., Suite 110 Itasca, IL 60143, U.S.A.
Phone: 630-250-8050, FAX: 630-250-8054

Los Angeles Office

371 Van Ness Way, Suite 120 Torrance, CA. 90501, U.S.A.
Phone: 310-328-6116, FAX: 310-328-6252

Dallas Office

2100 West N. W. Highway Suite 1145 Grapevine, TEXAS 76051, U.S.A.
Phone: 817-488-4528, FAX: 817-488-4714

Atlanta Office

3039 Amwiler Roed, Suite 118 Atlanta, Georgia 30360, U.S.A.
Phone: 404-242-3636, FAX: 404-263-8838

HITACHI DENSHI CANADA, LTD.*

Head Office

1 Select Avenue Unit#14 Scarborough, Ontario CANADA M1V 5J3.
Phone: 416-299-5900, FAX: 416-299-0450

Eastern Office

5795 Chemin St. Francois St. Laurent, Quebec CANADA H4S 1B6
Phone: 514-332-6687, FAX: 514-335-1664

Ottawa Office

9 Antares Drive, Nepean Ontario, K2E 7V5, Canada
Phone: 613-727-3930, FAX: 613-825-4253

HITACHI DENSHI (EUROPA) GmbH*

Head Office

Wesikircher Straße 88, Jüesheim D-63110 Rodgau, Germany
Phone: 06106-6992-0, FAX: 06106-16906

HITACHI DENSHI (U.K.) LTD.*

Head Office

14 Garrick Industrial Centre, Irving Way, Hendon, London NW96 AQ, United Kingdom
Phone: 0181-202-4311, FAX: 0181-202-2451

HITACHI DENSHI, LTD. BEIJING OFFICE

100004 Beijing Fortune Building 5,
Dong San Huan Bei-lu, Chao Yang District, Beijing China
Phone: 010-6590-8755/8756, FAX: 010-6590-8757

Beijing Service Center

B19, Bei San Huan Middle Road Beijing China
Phone: 010-6204-3901, FAX: 010-6204-3902

HITACHI DENSHI, LTD. SINGAPORE BRANCH

10 Anson Road #20-15 International Plaza singapore 079903
Phone: 65-223-0030, FAX: 65-223-0206

* Subsidiaries of Hitachi Denshi, Ltd.

Hitachi Denshi, Ltd.

9908 15③

Free Manuals Download Website

<http://myh66.com>

<http://usermanuals.us>

<http://www.somanuals.com>

<http://www.4manuals.cc>

<http://www.manual-lib.com>

<http://www.404manual.com>

<http://www.luxmanual.com>

<http://aubethermostatmanual.com>

Golf course search by state

<http://golfingnear.com>

Email search by domain

<http://emailbydomain.com>

Auto manuals search

<http://auto.somanuals.com>

TV manuals search

<http://tv.somanuals.com>