

Warranty

Knoll Systems warrants WTA-PACKs sold in the USA and Canada by authorized Knoll dealers to be free of defects in materials and workmanship. This warranty extends for three full years from the date of purchase by the original consumer. Any products returned to Knoll Systems and found to be defective by Knoll Systems within the warranty period will be repaired or replaced at Knoll Systems option, at no charge. Knoll Systems will not be responsible for the actual cost of installation or removal of the product, nor for any incidental or consequential damages. Some states do not allow the exclusion or limitation of incidental or consequential damages, so the above limitation may not apply to you. This warranty gives you specific legal rights. You may have additional legal rights that vary from state-to-state.

Specifications:

Frequency response	20 Hz – 20 kHz
Transmission frequency	2400 mHz – 2483 mHz
Distortion	0.3% @ 1 kHz
Output power	25 watts RMS per channel (4 ohms)
Peak output power	30 watts per channel (4 ohms)
Ideal impedance	4 - 8 ohms
SNR	95 dB
Transmitter output	0 – 18 dBm
Amplifier power	14 VDC
Transmitter power	3.6 – 6 VDC
Transmitter dimensions	3-1/2 x 2-3/4 x 1" (89 x 70 x 25 mm)
Amplifier dimensions	5-1/2 x 4-1/4 x 1-1/8" (140 x 108 x 29 mm)

Knoll Systems

145 Tye Drive Point Roberts, WA 98281
12140 Horseshoe Way, Richmond, BC V7A 4V5
Tel: (604) 272 4555, fax (604) 272 5595

Made in China



WRA-50 Amplifier WTA-PACK



50 Watt wireless stereo 2.4 GHz, 30 channel system Installation Instructions v1.0

Warning: To be installed and/or used in accordance with appropriate electrical codes and regulations.

Description: The WTA-PACK consists of a 50 watt WRA-50 amplifier and a WLT-02 transmitter. This system boasts a 64k sampling rate (higher than CD's 44.1k quality) and 2.4 GHz transmission. When multiple stereo transmissions are required, up to 30 WTA-PACK's can operate at the same time, in the same space without sound quality or overlap issues. Transmission distances can vary and should be tested. The WTA-PACK system can go thorough most walls and be reliable up to 100' (30 m) and 150' (45 m) outdoor line of sight. The shorter the transmission distance, the more reliable it will be. Transmitter remote control included.



- Small size, HUGE sound. Fits almost anywhere!
- Stereo amplifier has 25 watt RMS per channel rating.
- Up to 30 different stereo channels can operate in the same space at the same time.
- Transmission distances up to 100' (30 m)
- Super high quality due to 64k sampling rate with a latency of less than 0.5 msec.
- Transmitter remote control included.

Installation:

The maximum transmission distance can vary depending on several factors, including how much WI-FI traffic is taking place in the space at any given time and how much iron and steel is nearby. The rule of thumb is a maximum of 100' (30 m) through walls and 150' (45 m) outdoor in direct line of sight. In certain instances this system will encounter so much interference it may not work at all. We always suggest experimenting to see if it will work satisfactorily.

Connect the Knoll WRA-50 amplifier to the stereo speakers with 14-18 gauge wires. Plug the 14 VDC power supply into the power outlet with the WRA-50 power switch in the off position.

Connect the WLT-02 transmitter to the stereo source using the supplied RCA to 3.5mm stereo cord provided or another cord. Plug the 3.5 mm stereo jack into the WLT-02 jack labeled AUDIO. Plug the 3.6-6 VDC power supply into the power outlet with the WLT-02 power switch in the off (left) position.

transmitter using the remote or the WLT-02 CHANNEL SELECT push buttons to channel 25.

In most stand alone systems we suggest starting with channel 25, as this is at the high end of the WI-FI band and is generally less used by other WI-FI users. If a great deal of interference is detected this system is designed to temporarily mute or "dip out". If this happens repeatedly, try experimenting with other channels.

Turn the WLT-02 volume using the pushbuttons or remote control until it is mid way (about level 16 of 32). Make sure the WLT-02 gain set switch is in the left MUSIC position. Turn the WRA-50 amp volume up to about 1/3. Next push the WRA-50 CH+ button slowly to change channels until the correct channel is chosen and you can hear the source. Adjust the volume to a comfortable level and enjoy. Try experimenting with the transmitter and amplifier volume settings until the best quality sound is produced.

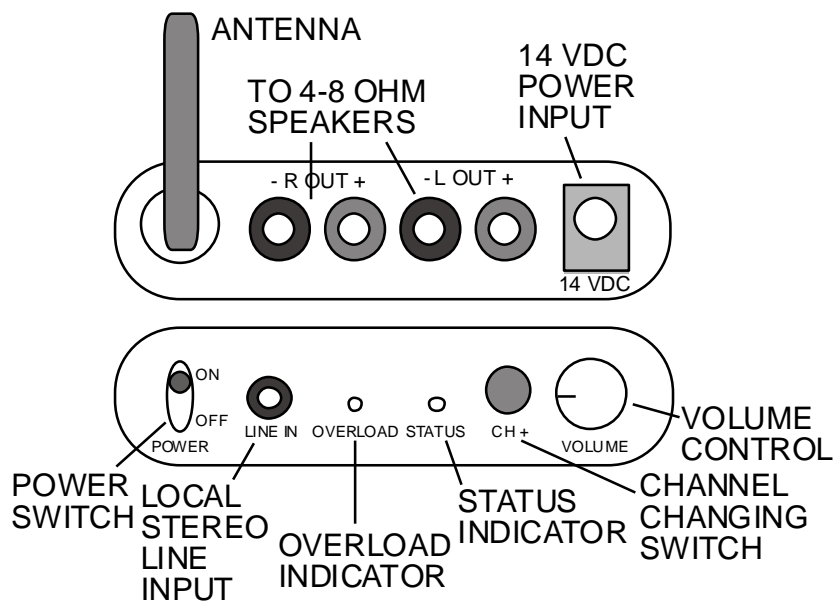

Fig. 1 WRA-50 AMPLIFIER

Operation:

Turn the stereo source music (iPod, CD player, stereo receiver etc.) on to a mid comfortable volume setting if it has a control. Move the switch on the rear of transmitter two clicks right to the ON position. Turn the WRA-50 amplifier power switch to the on position. If this transmitter is the only one in the area, change the

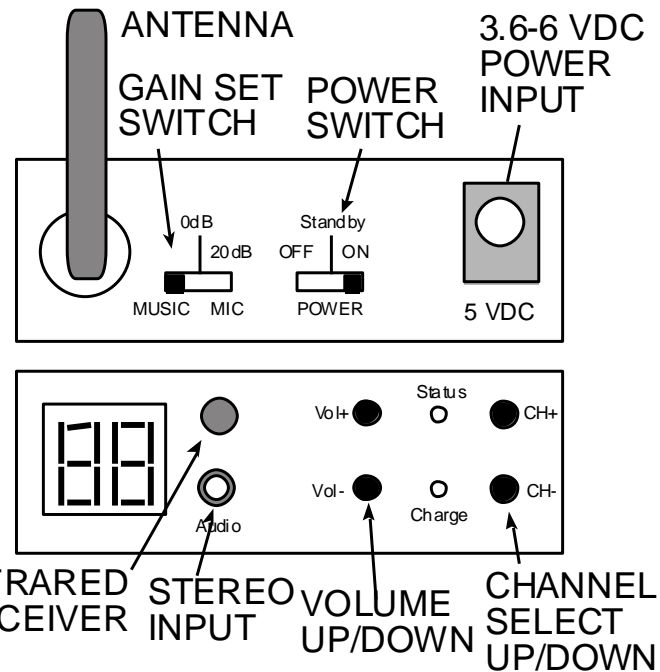

Fig 2: WLT-02 TRANSMITTER

The Knoll tech support line is (604) 272 4555 and is available from 8:30 to 5 PM Monday to Fridays Pacific time.

Free Manuals Download Website

<http://myh66.com>

<http://usermanuals.us>

<http://www.somanuals.com>

<http://www.4manuals.cc>

<http://www.manual-lib.com>

<http://www.404manual.com>

<http://www.luxmanual.com>

<http://aubethermostatmanual.com>

Golf course search by state

<http://golfingnear.com>

Email search by domain

<http://emailbydomain.com>

Auto manuals search

<http://auto.somanuals.com>

TV manuals search

<http://tv.somanuals.com>