

# **SERVICE MANUAL**

**FOR JACKSON MODEL:**

**MODEL 150B/PRB**

**FOR MODELS MAUFACTURED  
BETWEEN 1983 & 1989**



# TABLE OF CONTENTS

<u>SECTION</u>	<u>DESCRIPTION</u>	<u>PAGE</u>
I.	<b>GENERAL SECTION</b> Specifications	3
II.	<b>INSTALLATION &amp; OPERATION SECTION</b> General Instructions Dimensions Installation of Detergent Dispenser and/or Rinse Injection Equipment Operation Instructions	5 6 7 8
III.	<b>TROUBLESHOOTING/MAINTENANCE</b> General Instructions (Preventive Maintenance) Removal of Rinse and/or Wash Head Assemblies Timer for Model 150 Dishwashers Defective Timer Motor Function of Switches, Circuit Breaker and Indicating Lights Replacement of Switches in Control Panel Thermostat Adjustment Service Instructions (Incoming Water Solenoid Valve) Rinse Tank Heater System Wash Tank Heater System Replacing Seal and Ceramic on Wash Pumps Replacing Seal and Ceramic on Rinse Pumps Instructions for Adjusting Tension of Cantilever Applying Nylatron Strip to 150 Series Door Water Level Control (for Rinse Tank) Water Level Control (Initial Fill and Heat Circuits) Trouble Shooting Guide Front View Back View Right Side View Left Side View Bottom View High Level Probe/Low Level Probe/Vacuum Breaker/Incoming Plumbing Wash Sump Booster Tank Heaters Power Box Model 150: 208V - 220V/60 Hz/1 Phase Schematic Model 150B: 208V - 220V/60 Hz/1 Phase Schematic Model 150B: 208V - 220V/60 Hz/3 Phase Schematic Model 150PRB: 208V - 220V/60 Hz/1 Phase Schematic Model 150PRB: 208V - 220V/60 Hz/3 Phase Schematic	9 10 12 13 14 15 16 17 18 20 22 24 26 28 29 30 32 39 40 41 42 43 44 45 46 47 48 49 50 51 52 53

# SPECIFICATIONS

SPECIFICATIONS 150 SERIES ITEM # \_\_\_\_\_

MODEL	150	150B	150PRB
<b>Operating Capacity</b>			
Racks per hour (NSF Rated)	57	57	55
Dishes per hour	1425	1425	1375
Glasses per hour	1425	1425	1375
<b>Operating Cycle</b>			
Wash Time-Sec	45	45	45
Rinse Time-Sec	11	11	11
Total Cycle-Sec	60	60	60
<b>Wash Tank Capacity</b>			
Gallons	12	12	12
<b>Rinse Tank Capacity</b>			
Gallons	N/A	3	3
<b>Wash Pump Capacity</b>			
Gal Per Min	188	188	188
<b>Thermometers</b>			
Wash — °F	140-160	140-160	140-160
Rinse — °F	180-195	180-195	180-195
<b>Water Requirements (NSF Rated)</b>			
Inlet Temperature — °F	180	140	140
Gal per hour	99.7	99.7	97
Flow Pressure PSI	15-25	15-25	10-25
Flow Pressure PSI (Optimum)	20	20	20
Flow GPM	9.6	9.6	10.5
Inlet - I.P.S.	¾"	¾"	¾"
Drain - I.P.S.	1-½"	1-½"	1-½"
<b>Wash Pump Motor</b>			
Horsepower	1	1	1
<b>Rinse Pump Motor</b>			
Horsepower	N/A	N/A	½
<b>Electric Heat Wash</b>			
KW	1.5	1.5	1.5
<b>Electric Heat Rinse</b>			
KW	N/A	12.3 @ 220V 11.0 @ 208V	12.3 @ 220V 11.0 @ 208V

**Specifications 150 Series, cont'd**

<b>Dimensions</b>			
Length	24"	24"	24"
Width	24"	24"	24"
Height	63"	63"	63"
Standard table height	34"	34"	34"
Maximum Clearance for Dishes	15"	15"	15"
<b>Standard Eq. Racks</b>			
Dish 19- <sup>3</sup> / <sub>4</sub> x 19- <sup>3</sup> / <sub>4</sub>	2	2	2
Combination	2	2	2
<b>Shipping Weight</b>			
Approximate basic model	400	400	400
<b>Electrical Rating</b>			
<b>Model</b>	<b>Volts</b>	<b>Phase</b>	<b>Approximate Total Load Amps</b>
150	208V or 220V	1	16
150B	208V	1	65
150B	220V	1	68
150PRB	208V	1	65
150PRB	220V	1	68
150B	208V	3	38
150B	220V	3	40
150PRB	208V	3	38
150PRB	220V	3	40

**Specifications subject to change without notice.**

# GENERAL INSTRUCTIONS

(INSTALLATION/DIMENSIONS) FOR 150B, PRB SERIES

**NOTE:** Read the following instructions carefully. Proper installation of your Jackson Dishwasher will assure proper machine operation.

1. Open side doors, the front door (hook open) and remove dish, cup, and glass racks, and set to one side for later use. Remove the tape holding the overflow strainer, the pump intake strainer, the wash head assembly and the rinse head that are inside the machine.
2. Cut straps holding machine to base of crate, ease machine onto floor and slide into place of installation.
3. Connect drain to bottom of machine (1½" IPS female fitting on bottom of wash sump) with proper slope to conform with local and/or national codes. Drain is a gravity feed system from machine.
4. **The incoming water line to the unit must be ¾" with the capacity to supply 10.5 gallons per minute with a flow rate of 20 PSI. The temperature at the unit must be 140° F.** This connection is just before the Y-strainer. Connect to conform with local and/or national codes (STANDARDS).
5. Electrical connections should be made through hole in bottom of power box to terminal board inside (to the right lower side of control box). This terminal board is accessible by removing the lower cover plate on control box. The terminals are marked L1, L2 (requiring 208—230V, single phase), or L1, L2, L3 (requiring 208—230V, three phase). There is a grounding lug inside of the power box on the bottom left. Be sure all connections made are tightened properly. Refer to data plate for Voltage and Amperage totals.
6. Install the proper circuit breaker, wire, and conduit size to conform with local and/or national codes. Refer to data plate for electrical loads.
7. **DO NOT APPLY POWER UNTIL STEP 10.**
8. Insert pump intake strainer and overflow strainer, then close door.
9. Turn on hand valve controlling water supply to machine; check for any leaks in plumbing and connections.
10. To energize electrically, proceed as follows:
  - a. Turn on customer's circuit breaker controlling machine.
  - b. Check voltage at incoming terminal L1, L2, and L3 (if applicable). It should match data plate voltage. Voltage at L1 and L2 should be checked to ground individually to ensure that a high (or wild) leg is not connected to L1 or L2. (Voltage exceeding 150V to ground would indicate high leg).
  - c. If voltages are in required range, turn on 15 amp circuit breaker on side of power box. The 15 amp circuit breaker protects and controls the motors and control circuit only; it is not meant to protect or control the rinse heaters.
  - d. Insert a rack into the machine and close all doors.
  - e. Turn on the power switch; this supplies voltage to the operating controls. Then depress the rinse/fill switch. The unit will automatically fill the wash tub with water to a specific level.
  - f. Open the front door and check the water level. It should be ¼" below overflow level. If not, check the incoming water line making sure that the solenoid valve fully opens and closes as the switch is turned on and off.
  - g. If the water is at the proper level, close the front door and observe the temperature gauges; the rinse temperature should rise to the specified level of 180° within five minutes if the incoming water temperature is 140° to the booster tank.
  - h. The wash heater will take longer to reach 150°F, as the element is designed for maintaining temperature, not heating.
  - i. Turn the manual wash switch on with the door closed. You should hear the water being pumped as it strikes the top of the machine. Turn off the manual wash switch.
  - j. The unit is now ready to proceed with the washing of dishes in accordance with the operating instructions in this manual and the instruction sticker on the front door of the dishwasher.

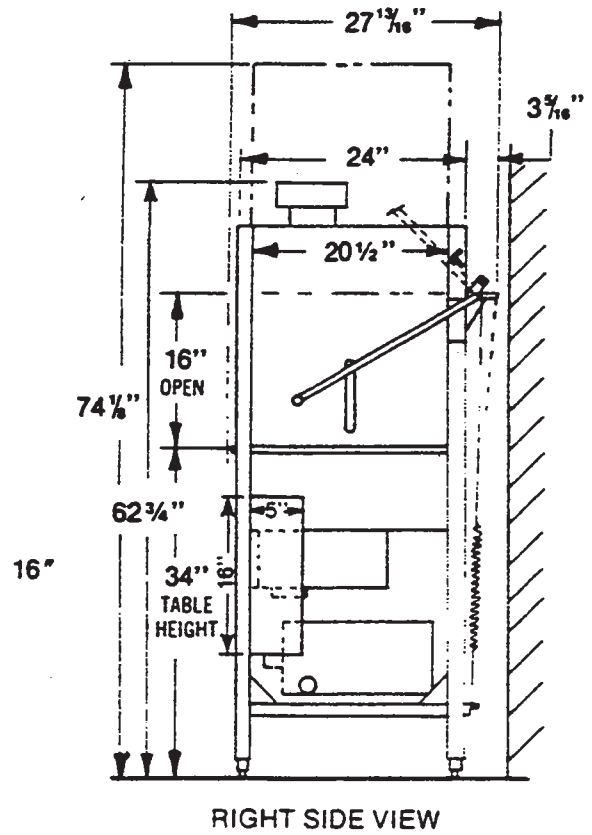
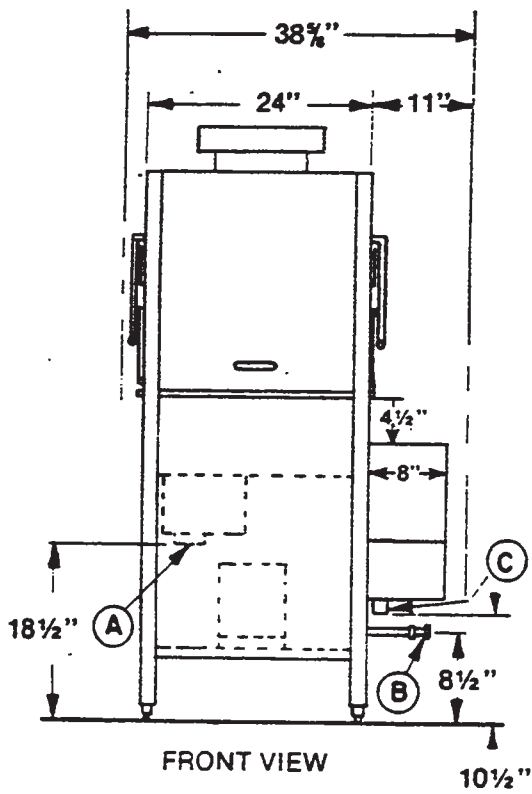
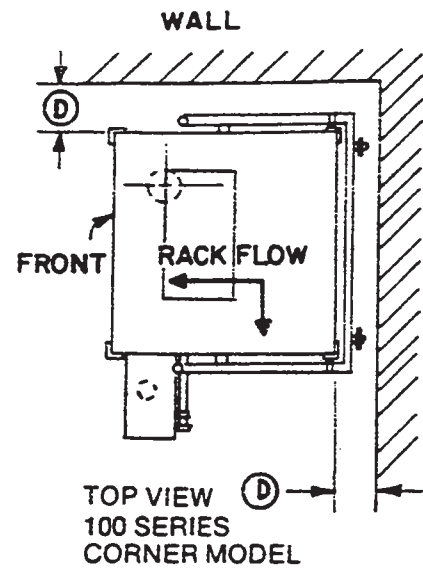
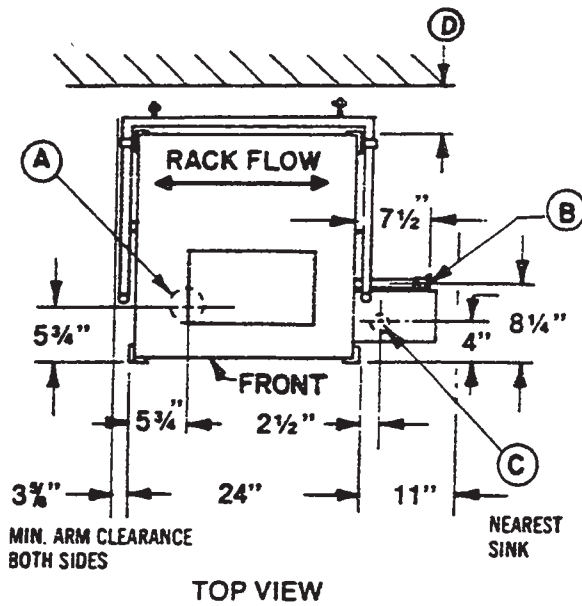

**NOTES:**

- A—Drain 1 1/2", I.P.S.
- B—Water Inlet 3/4", I.P.S.
- C—Electrical Connection
- D—Standard Wall Clearance W/Dishtable 3 3/8"

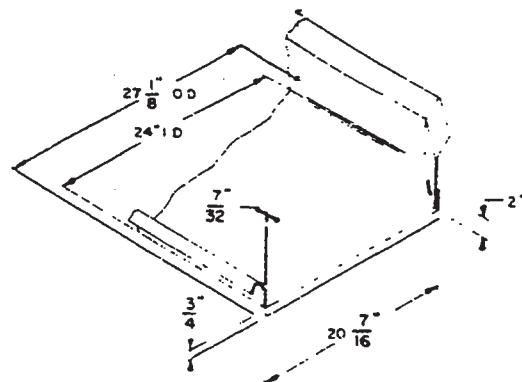

**150 SERIES TABLE CONNECTION**

# **INSTALLATION of DETERGENT DISPENSER and/or RINSE INJECTION EQUIPMENT**

Located in the back of the control box on top of the machine is a knockout which is provided for a ½" conduit fitting. Terminals DT-1 and DT-2 provide line voltage (208/220VAC) during the machine cycle. Equipment connected **must not exceed 0.5KVA**. Connections **MUST** be made with suitable materials and **MUST** be in accordance with all applicable codes. **ALL ELECTRICAL CONNECTIONS MUST BE MADE BY QUALIFIED PERSONNEL**.

Two fuses are needed to meet the requirements of the dispensing equipment being put on the unit. These fuses should be sized to meet the requirements of the dispensing equipment, however, they should not exceed 2.5 amps.

Located on both sides of the machine are nylon bulkhead fittings either of which must be removed or modified for the detergent entry port.

Located on the bottom of the wash tank of the machine is a nylon bulkhead fitting which must be removed in order to install the detergent equipment sensing probe.

Located in the fitting adjacent to the vacuum breaker is a pipe plug which must be removed in order to install a rinse agent dispensing devise.

# GENERAL INSTRUCTIONS

(OPERATION) 150B, PRB

**READ INSTRUCTIONS CAREFULLY:** Proper operation of your Jackson Dishwasher will assure clean and sanitized glasses and dishes at optimum efficiency.

## DISH PREPARATION

1. Scrape the dishes thoroughly.
2. Pre-rinse the dishes by soaking or by spraying off with a pre-rinse hose.
3. Place the dishes and cups in the dish rack with the cups upside down.
4. Place the glasses and silverware in the combination glass-silverware rack with the glasses upside down. Scatter the silverware loosely on the bottom of the rack. Do not put glasses on top of the silverware.

**NOTE:** When silverware is in an upright position, it washes and rinses better than lying flat. These compartment silverware racks are available through your dealer or service agency.

## MACHINE OPERATION

1. Open the front door and insert the pump intake strainer and overflow strainer.
2. Close all of the doors.
3. Turn the power switch on. Depress the rinse/fill switch and release. The machine will now automatically fill the wash tank and energize the wash and rinse heater control circuit.
4. Allow the temperature to rise to the required temperatures on the wash (150°) and rinse (180—195°) gauges.
5. Raise up the side doors. Slide in a rack of dirty dishes.
6. Add detergent\* (see Detergent Recommendation). If an automatic detergent dispenser is used, follow the manufacturer's instructions.
7. Lower all of the doors.
8. Start the automatic wash and rinse cycle of the dishwasher by depressing the start switch (right-hand side) and releasing. Cycle will continue with switch in center (auto) position. Left-hand position of switch (manual) is intended for use if timer is inoperable. Panel light will indicate cycle function.
9. When the ready light comes on, open the side doors, slide out the rack of clean dishes, slide in another rack of dirty dishes, and then repeat steps 6, 7, and 8.
10. At the end of a meal period or the end of the day, shut off the power switch. Drain the machine by removing the overflow strainer. Clean both strainers, the overflow and the inside strainer, of all foreign debris and build-up and flush out the unit.

**\*DETERGENT RECOMMENDATION AND RINSE ADDITIVES:** We suggest you contact your local detergent specialists for the correct detergent and rinse additives for the area. To help until one can be reached, we suggest that you use a non-foaming dishwasher detergent, approximately one-quarter cup in wash tank, when machine is filled the first time, then one level tablespoon each cycle (or load) thereafter. This may have to be increased or decreased to obtain satisfactory results.

When manually dispensing powdered detergent in wash tub, always distribute over a sufficient area to prevent build-up. Some detergent, when dispensed in a small or concentrated area, may cause deterioration of the stainless tub or sump.



# GENERAL INSTRUCTIONS

## (PREVENTIVE MAINTENANCE)

(The following is to be performed as needed.)

**READ CAREFULLY:** Proper maintenance of your Jackson Dishwasher will insure optimum service with a minimum of down time.

1. To remove all lime and corrosion deposits.
  - a. Fill the machine with wash water as would ordinarily be done for washing.
  - b. Open door and place one cup or less of de-liming compound into the water (be sure to follow their directions if they vary from these being given) which is available from your detergent supplier.
  - c. Turn on the manual wash switch and allow to wash for five minutes.
  - d. Open door and examine the interior. All lime should be removed and parts should be shiny. If not, allow to wash for longer period.
  - e. After the interior is clean, empty the wash water by removing overflow strainer.
  - f. Replace overflow strainer. Refill machine and allow to run for two minutes, then, again drain the wash reservoir.
  - g. Refill as it is ready for regular operation.
2. Clean strainers.
  - a. Clean around overflow and pump intake strainer holes.
  - b. Clean around pump intake (toothbrush makes excellent tool for cleaning).
3. Clean Y-strainer on incoming water line. (Water to machine must be turned off for this operation.)
  - a. Remove plug and clean strainer.
4. Clean rinse tubes.
  - a. Remove end plugs on lower and upper rinse.
  - b. Clean all rinse tubes with special brush supplied.
  - c. If spray holes in the rinse tubes are clogged, they may be cleaned with a pointed tool.
5. Clean wash head assembly.
  - a. If spray jets are plugged, use pointed tool to dislodge and flush with water.
  - b. If lodged items still remain in wash tubes, remove wash assembly by first removing rinse assembly.
  - c. Clean assembly at sink by flushing water through spray jets.
  - d. Reinstall wash and rinse assemblies. (See page with instructions.)
6. Clean any deposits which may have built up on exterior moving parts.

# REMOVAL of RINSE and/or WASH HEAD ASSEMBLIES

## GENERAL INSTRUCTIONS

1. Turn power switch to off position.
2. Open door and drain machine by lifting overflow strainer.
3. When empty, replace overflow strainer.
4. With wrench, remove pipe fitting holding lower rinse feed pipe to machine and remove feed pipe and rinse head assembly.
5. Locate Allen head set screw in wash head cap, insert Allen wrench and loosen screw by turning counterclockwise.
6. Turn wash head cap counterclockwise until cap is removed, and put cap in safe place.
7. Remove ¼" stainless ball bearings carefully and put in a receptacle in a safe place. If any should drop in machine, you will be able to locate and retrieve if you left the overflow strainer in as suggested in step #3 above.
8. Lift and remove small manifold with short tubes. Put in safe place.
9. Remove ¼" ball bearing in similar method to step #7.
10. Lift and remove large manifold with long length tubes similar to step #8.
11. The lower fixed race may be left in place.
12. Clean ball bearings by soaking in de-liming solution.
13. Ball bearing race ways may be cleaned by either brushing with de-liming solution (toothbrush makes excellent tool) or gently clean by rubbing with fine sandpaper or emery cloth.
14. Rinse ball bearings and manifolds thoroughly.
15. To reassemble, first, fill lower race to capacity with ¼" ball bearings then remove one. This will give proper movement needed during rotation of assembly.
16. Replace lower manifold and fill race fully with ¼" ball bearings. Repeat, removing one only.
17. Replace upper manifolds and repeat necessary parts of step #15.
18. Replace wash cap by screwing on center shaft clockwise, finger tight.
19. Back off wash cap about ¼ turn and tighten Allen set screw.
20. Rotate manifolds in opposite directions; see if they rotate freely. A rule of thumb is to select the longest tube in the bottom manifold and make sure it moves up and down at least ¼" and no more than ¼".

21. Replace rinse assembly and feed pipe.
22. Close all doors and refill dishwasher.
23. Run through several cycles and recheck wash arms for easy movement. Adjust if necessary.
24. If removal of upper wash or rinse assembly is necessary, then extra care must be taken to support assembly. It will drop as one unit, but will be subject to falling apart as wash cap is removed.

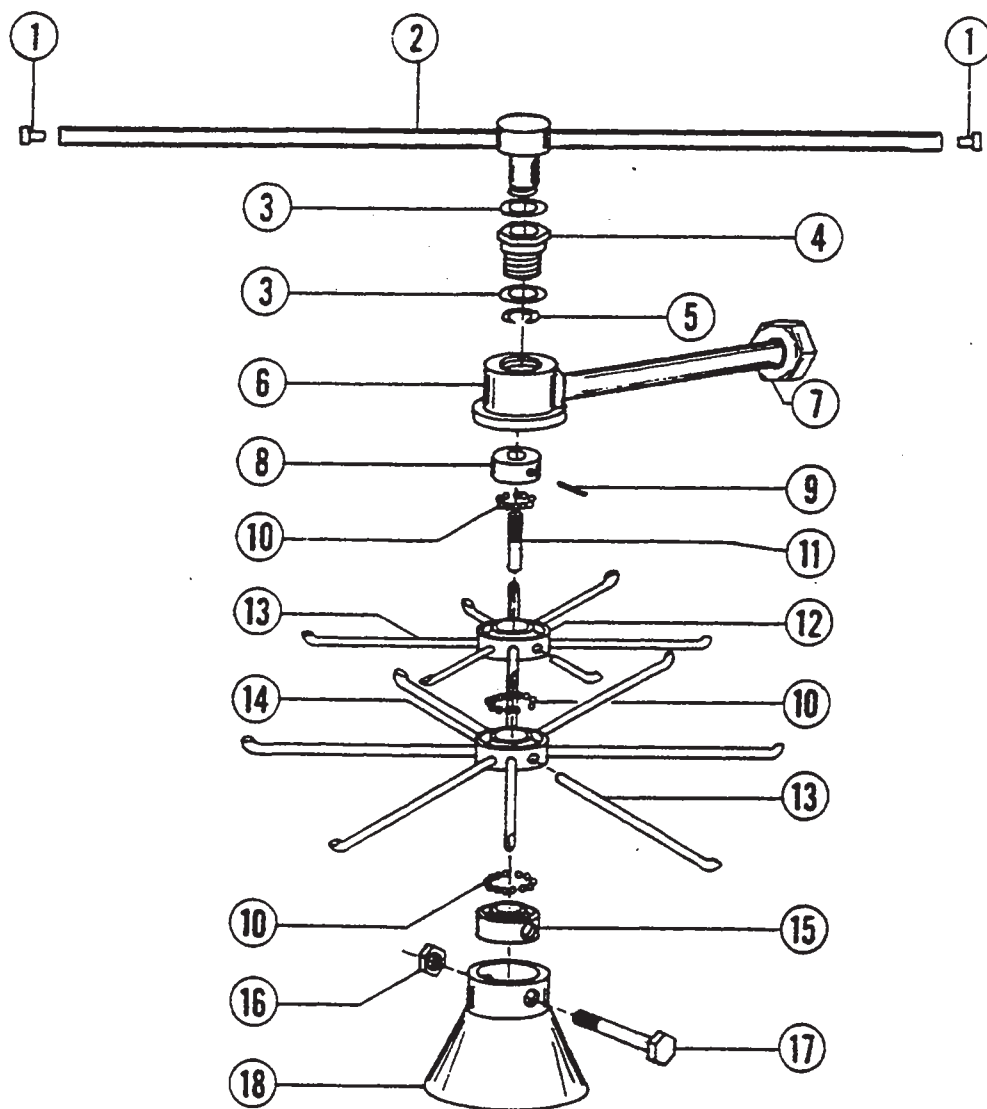

ITEM	P/N	DESCRIPTION
1	0126800	END PLUG
2	0136000	RINSE ARM BODY
3	0133000	NYLATRON WASHER (2 PLACES)
4	0132500	HEX NUT
5	0133500	SNAP RING
6	0137000	LOWER RINSE FEED PIPE
7	0137000	RINSE FEED PIPE COUPLING OR NUT
8	0186500	WASH CAP
9	0187000	WASH CAP SET SCREW

ITEM	P/N	DESCRIPTION
10	0194000	BALL BEARINGS (3 PLACES)
11	0187500	CENTER SHAFT
12	0200500	SMALL MANIFOLD
13	0194500	SPRAY TUBE (16 PLACES)
14	0201000	LARGE MANIFOLD
15	0193500	FIXED RACE
16	0044700	HOLDING NUT
17	0188500	HOLDING BOLT (BEFORE S/N 4105)
17A	0188601	HOLDING PIN (AFTER S/N 4105)
18		WASH HEAD BASE

# TIMER FOR MODEL 150 DISHWASHERS

## General Description

The timer is a self-contained (frame-mounted) timer of the repeating cycle type. It is mounted in the control box of Jackson Automatic Dishwashing machines to control the automatic functions of these machines. It consists of a clock motor which operates on 60 cycle AC, 208/220 VAC. In addition to the clock motor, the timer also contains a driven cam arrangement which operates four micro switches.

## Principle of Operation

The timer controls various operations of the automatic washers as per wiring diagram for each machine, however, the timing cycle and the micro switches are the same for each model. The time for ONE COMPLETE REVOLUTION of the cam shaft is approximately 60 seconds, allowing one wash and one rinse operation for each complete revolution of the cam shaft. The micro switch nearest the timer motor is the hold circuit and uses both the NO and NC contacts. The second micro switch is the total cycle circuit and uses both the NO and NC contacts. The third micro switch controls the wash and uses both the NO and NC contacts. The micro switch farthest away from the timer motor controls the rinse and uses just the NC contact.

## Service Instructions

**CAUTION: ALWAYS REMOVE THE POWER TO THE MACHINE BEFORE WORKING IN THE CONTROL BOX OR WHILE SERVICING THE COMPONENTS IN THE POWER BOX. ALL ELECTRICAL CHECKS SHOULD BE MADE BY QUALIFIED PERSONNEL**

Timer operation can be observed after removing the covers from the control box by loosening the two screws holding each cover in place.

If it is determined that the timer is defective, it is recommended that a new timer be installed. However, limited field maintenance can be accomplished as follows:

A frozen contact on a micro switch will be indicated by one function being executed all the time or the absence of a click when the switch arm is actuated. The micro switch is replaced by:

### For Bristol-Saybrook Timer:

Remove micro switch by moving terminal end of switch away from cams about ¼" and pulling switch straight out. Replace new switch in reverse order.

### For Eagle Signal Timer:

1. Remove all wires from the timer, properly tag them to assure proper replacement.
2. Remove the two screws which hold the timer to the control box.
3. One screw holds the micro switches, cams and actuating arms in the frame. This screw is seen on the side opposite the motor. Remove this screw. NOTE: Be sure to note which cam goes with which micro switch.
4. The unit can now be taken apart and the defective micro switch replaced.
5. Reassemble. NOTE: The flanges on the cams are such that they only mesh in one direction. The shorter flange on the cams always points toward the drive motor.

The timers cam drive system is equipped with a clutch to enable one to view the operations of the cams and micro switches. Remove power to machine BEFORE touching timer. Rotate cams by turning with fingers; cams will turn in one direction only. Do not force them. As cams actuate switches, listen for the click of the switch or test the switches with an ohmmeter.

# DEFECTIVE TIMER MOTOR

A defective motor is indicated by the fact that the cams do not rotate or the machine does not perform the automatic operations or performs a specific part of the cycle continuously, but works okay on manual. Remember, the timer motor is controlled by the start switch and the hold micro switch, check this complete circuit before changing motor. The motor is replaced by:

1. Remove motor leads from connection points.
2. Remove the two screws which hold the motor.
3. Replace the new motor.
4. Re-connect motor leads to proper points.

**NOTE:** It may be necessary to remove complete timer to replace motor; if so, follow steps 1 and 2 on previous page.

## TYPICAL TIMER SWITCH P/N 0177500

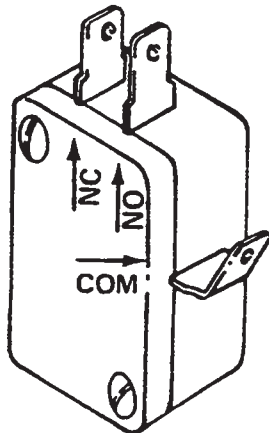

**TIMER P/N 0173900**

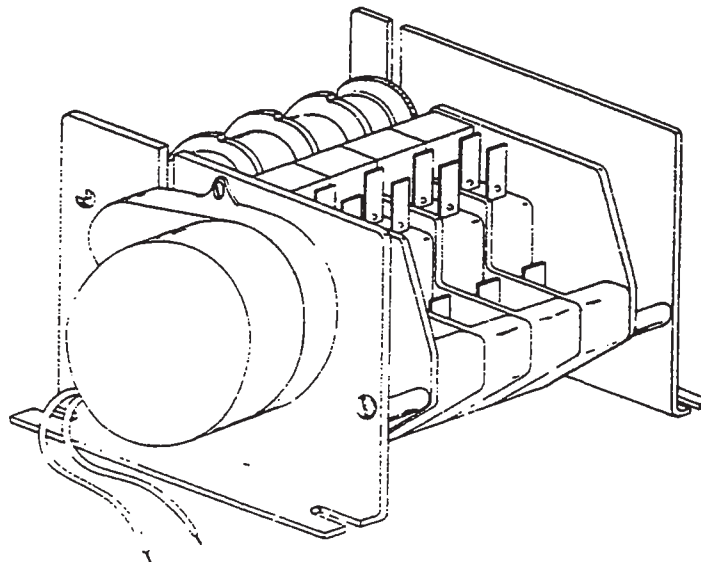

# FUNCTION of SWITCHES, CIRCUIT BREAKER and INDICATING LIGHTS

<b>Circuit breaker</b> P/N 0012000	Rated 15 amps, controls power to control circuit only, I.E. timer, relays, solenoid valve, water-level control and motors. Circuit breaker does not cut off power in power unit box at incoming terminal board and rinse heater or its relay contacts. Power is still applied to them when the circuit breaker is in "off" position.
<b>Power switch</b> P/N 0162000	This switch interrupts all power going to the control circuit; this means that all switches on control panel are inoperable until switch is turned "on."
<b>Cycle switch</b> P/N 0158900	This switch controls the timer motor and has three positions. The start position (right-hand side) is spring-loaded and is used to initiate the automatic cycle. In the event of timer failure, the left side of the switch must be engaged to disable the timer for manual mode of operation.
<b>Manual Cycle Switch</b> P/N 0155600	This switch is used to initiate either a manual wash or rinse operation as well as initiate the initial fill of the machine. Depressing the left side of this switch will cause the wash pump to run until returned to the center position. The prime purpose of this switch position is to extend the wash period for extremely soiled dishes before putting them through its normal automatic cycle. The right side of this switch is spring-loaded and must be held down for manual rinse operation; it however needs only to be depressed momentarily to initiate the automatic fill of the machine. Either position may also be used as an emergency back-up should the timer fail to operate, in which case the cycle switch should be placed in the manual mode.
<b>Power light</b> P/N 0083518	This red indicating light remains lit whenever the power switch is on.
<b>Ready light</b> P/N 0083507	This green light comes on only when automatic cycle is ready to start and extinguishes during cycle.
<b>Wash light</b> P/N 0083501	This amber indicating light comes on during the wash cycle.
<b>Rinse light</b> P/N 0083501	This amber indicating light comes on during the rinse cycle.

# REPLACEMENT of SWITCHES in CONTROL PANEL

There are three switches installed in the control box front panel. These are the power, cycle, and manual wash-rinse/fill switches.

Before working on machine, it is important that power be turned off at customer's circuit breaker. To prevent the possibility of electrical shock, trip breaker to "off" position. Then turn machine breaker "off" located right side of power box.

Remove the cover from the control box by removing the two screws holding it in place. Remove the electrical cover from within the control box by removing the two screws holding it in place.

If the switch is found to be defective, insert a new one into the cutout in the control box. Replace the wires from the used switch terminal by terminal onto the new switch.

Power can now be applied to the dishwasher and run through cycles checking all operations.

1. CONNECTION TERMINALS
2. RETAINING CLIPS
3. FRONT PANEL
4. SWITCH BEZEL
5. ROCKER BUTTON

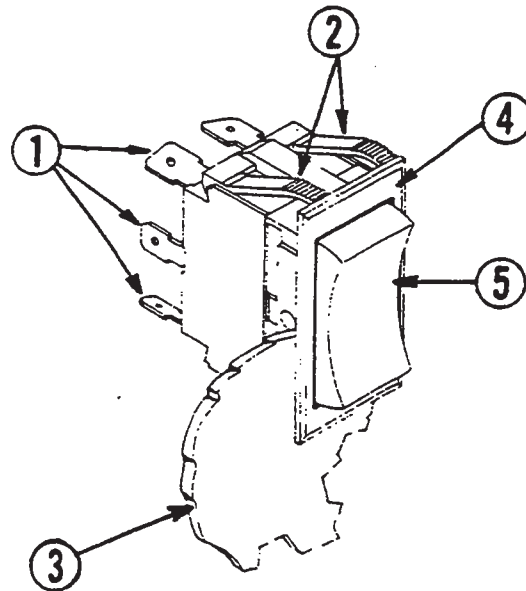

# THERMOSTAT ADJUSTMENT

The thermostat can be adjusted by turning screw #1 (see picture) on the thermostat control box cover. (Remember the present setting, in case the problems are elsewhere in the control circuit.) A CW rotation is used to obtain a lower temperature setting and a CCW rotation is used to obtain a higher temperature setting. A  $\frac{1}{4}$  turn of screw #1 changes the temperature approximately 4°F. If screw #1 is turned all the way to its stop in either direction, adjust screw #2 as follows. **DO NOT TOUCH THE SCREW SEALED WITH RED PAINT.** When adjusting screw #2, power should be disconnected during adjustment.

Set screw #1 so that it can be turned equal distances in either direction, then:  
—if screw #1 stopped while turning in CW direction, turn screw #2 in CW direction slowly and only  $\frac{1}{8}$  of a turn or less per complete cycle of the unit.

—if screw #1 stopped while turning in CCW direction, turn screw #2 in CCW direction slowly and only  $\frac{1}{8}$  of a turn or less per complete cycle of the unit.

Three-fourth's of a turn will bring the thermostat to approximately the same setting obtained where screw #1 stopped. Check the present temperature setting before attempting any further adjustments. Use screw #1 for any further adjustments.

**NOTE:** Making large moves in adjusting may cause misalignment, thus increasing the chances that further adjustment cannot be made and the thermostat will have to be replaced.

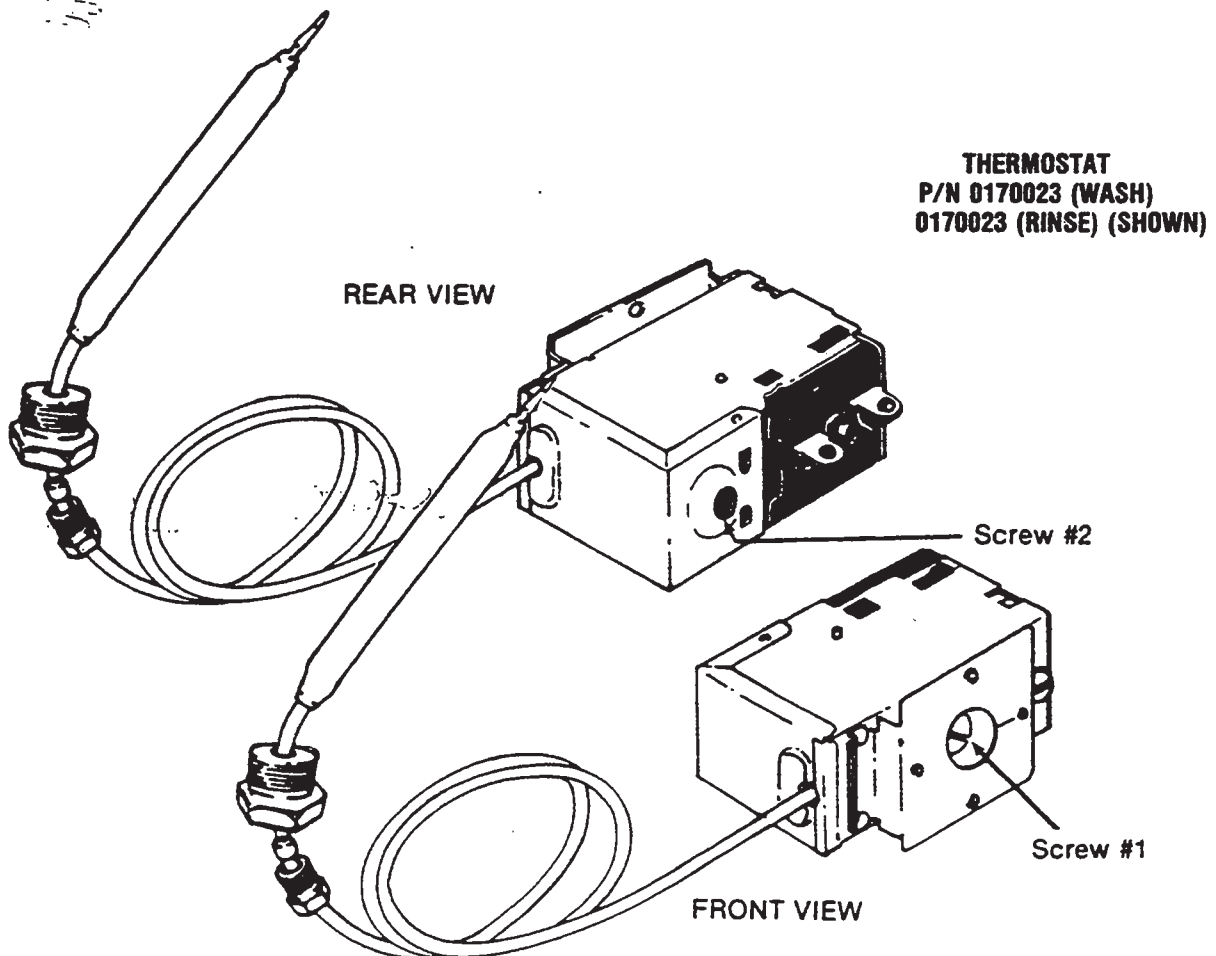



# SERVICE INSTRUCTIONS

(INCOMING WATER SOLENOID VALVE)

## SOLENOID VALVE

### TO TAKE THE VALVE APART

**DISASSEMBLY** - These valves may be taken apart by unscrewing the bonnet and the enclosing tube assembly from the valve body assembly. See Fig. 3. After unscrewing, carefully lift off the bonnet and enclosing tube assembly. Don't drop the plunger. The "O" ring seal and diaphragm cartridge can now be lifted out.

Be careful not to damage the machined faces while the valve is apart.

**TO REASSEMBLE** - Place the diaphragm cartridge in the body with the pilot port extension UP. Hold the plunger with the synthetic seat against the pilot port. Make sure the "O" ring is in place, then lower the bonnet and enclosing tube assembly over the plunger. Screw bonnet assembly snugly down on the body assembly.

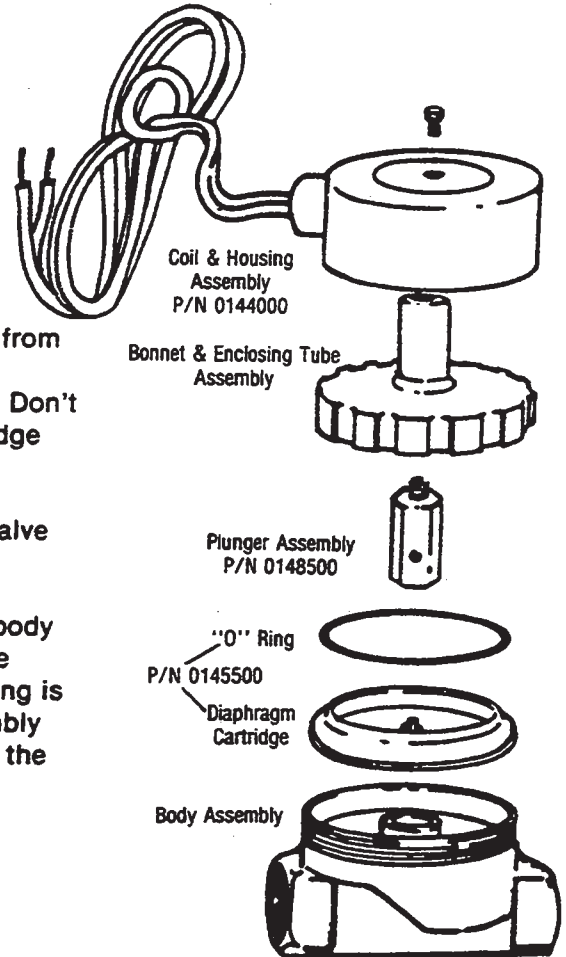
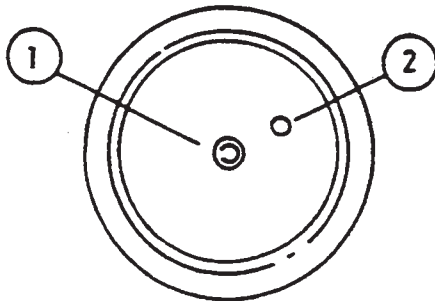

FIG. 3

### DIAPHRAGM CARTRIDGE P/N 0145500



### POSSIBLE PROBLEMS

**Pilot Port extension #1 clogged**

**Hole #2 clogged**

### REMEDY

**Pass heated straight pin through hole #2  
or clean hole #1**

# RINSE TANK HEATER SYSTEM

## FUNCTION

The Rinse Tank Heater System is electrically connected in the circuit so that it is dependent upon the dishwasher being properly filled with and maintaining a safe water level. The automatic fill system, therefore, should operate properly before the heat system can be engaged. The circuit is controlled by a power switch (mounted on the front control panel), a thermostat (mounted behind the lower front panel), a water level control (mounted in the control box), and a heater relay (mounted in the control box), with the coil being activated by the thermostat.

## INDICATORS OF POSSIBLE MALFUNCTION

Once the machine has been properly filled, the heat circuit should operate by merely turning on the power switch. Should the rinse tank heat, be it either too high, too low, or no indication of temperature at all, the following checkouts should be made.

## CHECKOUT OF HEATER SYSTEM FOR RINSE TANK (Refer to drawing, figure 1)

**NOTE: THE FOLLOWING CHECKOUTS SHOULD BE DONE BY A QUALIFIED SERVICE PERSON OR ELECTRICIAN.**

1. If temperature is too high: adjust thermostat, using thermostat instructions in this manual.
2. If temperature is too low, adjust thermostat as above, then:
  - a. Turn off power to machine by tripping customer circuit breaker to "off" position. Turn off machine circuit breaker located on right side of power box.
  - b. Remove lower cover plate on power box (held by single screw).
  - c. Make sure rinse temperature is below 180° (preferably about 140°).
  - d. Turn on both circuit breakers. Observe heat relay (3 or 4 pole, mounted lower left inside power box) while power switch is turned "on" and "off." If relay contacts move in and out, see instructions under "B"; if not, proceed with "A."

**A:** If heat relay does not close:

1. There is an insulated movable bar on the relay across the top of the four contacts. With insulated probe, depress this bar and observe the rinse thermometer; the temperature should rise noticeably in a minute or two. If it moves very slowly, it would indicate that one or more elements are faulty. If it moves constantly higher at a good rate, elements are okay.

**NOTE:** A check with an amp probe (if available) at position shown in fig. 1, can be made. Each element should draw 26-28 amps with a total approximate amperage draw of 52-56 amps for both elements. (Single phase). Replace any defective elements.

- A. 2. With power switch on:
  - a. Check position 1, figure 1. Voltage should be 208-230; if not, checkout heat switch and replace if necessary.
  - b. Check position 2; there should be no voltage. If there is, readjust thermostat per thermostat adjustment instructions.
  - c. Check position 3; voltage should be approximately 120V to ground.
  - d. If voltage being applied on positions 1, 2, and 3 checks out okay, then the relay should be replaced. Coil is probably defective.

If heat relay closes:

1. Check power supply at incoming terminal board L1 and L2. It should be 208-230V, approximately.
2. Check power at positions 4 and 5, fig. 1. Voltage should read approximately 208-230V; if not, check wires for breaks or bad connections.
3. Check power at positions 6 and 7. Voltage should be approximately 208-230V. If not, check wires for breaks or bad connections.
4. Temperature should rise as explained in A1 and amperages may be checked according to those instructions. Replace any defective elements.

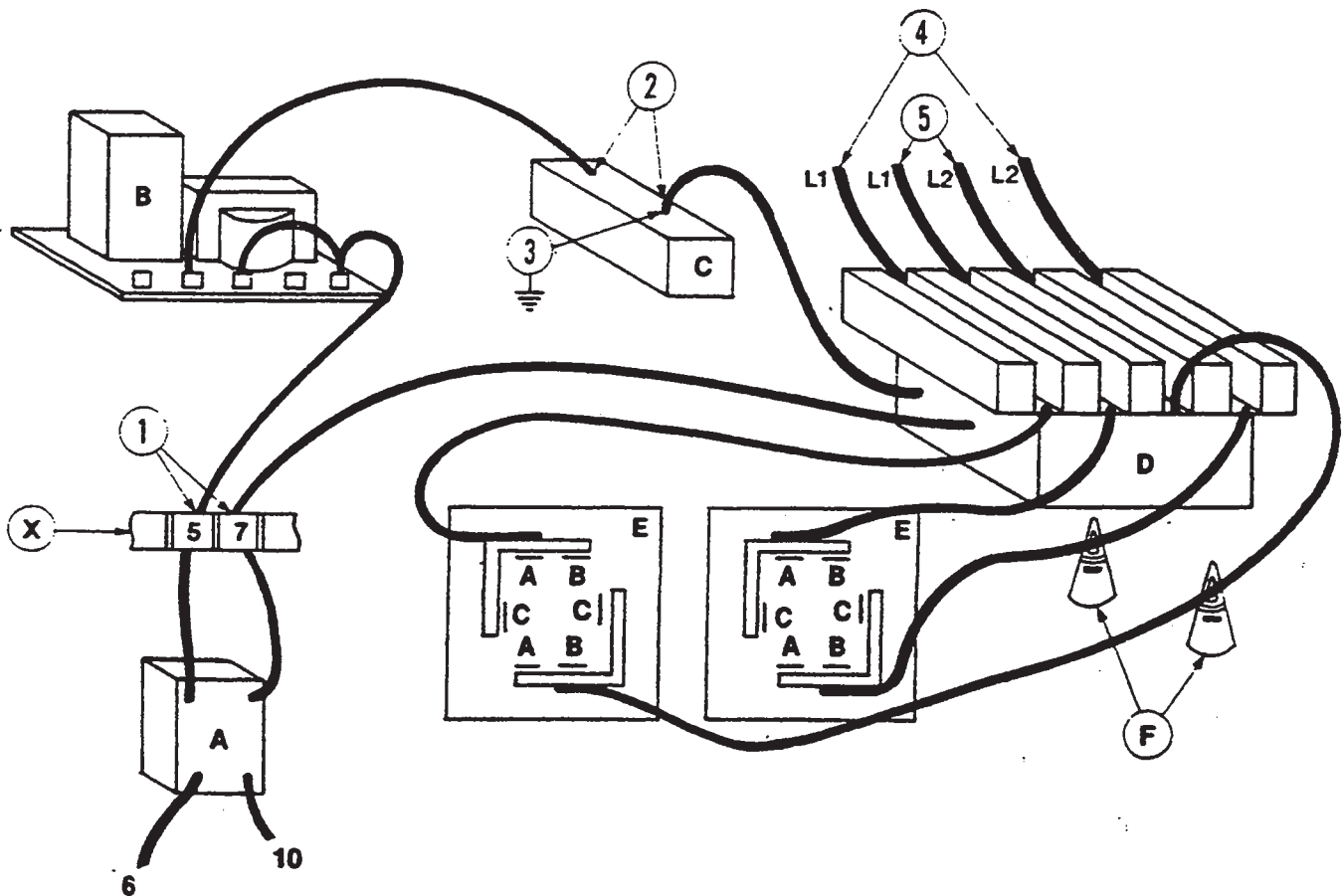

**FIGURE NO. 1 RINSE HEATER SYSTEM      SINGLE PHASE**

- A. POWER SWITCH**
- B. WATER LEVEL CONTROL**
- C. THERMOSTAT**
- D. HEATER RELAY**
- E. RINSE TANK HEATERS**
- F. AMPROBE TEST POSITION**
- X. TERMINAL BOARD (9 TERMINALS)**

# WASH TANK HEATER SYSTEM

## FUNCTION

The Wash Tank Heater System is electrically connected in the circuit so that it is dependent upon the dishwasher being properly filled with and maintaining a safe water level. (As an additional safety precaution, never leave the machine turned on without adequate water nor drain the machine without first turning off the power switch.) The circuit is controlled by a power switch (mounted on the front control panel), a water level control (mounted in the power unit box), a thermostat (mounted behind the lower front panel), and a heater relay (mounted in the power unit box), with the coil being activated by the thermostat.

## INDICATORS OF POSSIBLE MALFUNCTION

Once the machine has been properly filled and the heat system engaged, the heat circuit should operate by merely turning on the power switch. Should the wash tank be either too high, too low, or no indication of temperature at all, the following checkouts should be made.

## CHECKOUT OF HEATER SYSTEM FOR WASH TANK (Refer to drawing, fig. 2)

**NOTE: THE FOLLOWING CHECKOUTS SHOULD BE DONE BY A QUALIFIED SERVICE PERSON OR ELECTRICIAN.**

1. If temperature is too high: adjust thermostat, using thermostat instructions in this manual.
  2. If temperature is too low: adjust thermostat, using thermostat instructions in this manual.
  3. If step one or two does not correct the problem, proceed as follows:
    - a. Turn off power to machine by tripping customer circuit breaker to "off" position. Turn machine circuit breaker on right side of power unit box to "off."
    - b. Remove cover from power unit box.
    - c. Reapply power to unit.
    - d. Wash tank must be emptied, then refilled for each checkout.
    - e. Wash temperature must be 130 degrees or less. Observe wash heater open switching relay (two pole), located top relay on left side. Turn power switch on and off; if relay contacts move in and out, see instructions under BB, if not, proceed.
- AA. If heat relay doesn't close:
1. There's an insulated bar across the top of two contacts. With insulate probe, depress this bar and observe wash thermometer; temperature should rise slowly. Watch for approximately five minutes; if temperature doesn't rise, replace element. If amprobe E is used, the element should draw approximately 7 amps.
  2. With power switch on:
    - a. Check position 1, figure 2. Voltage should be 208-230V. If not, check out and replace heat switch.
    - b. Check position 2; there should be no voltage. If there is, readjust thermostat per thermostat adjustment instructions.
    - c. Check position 3; voltage should be approximately 120V to ground.
    - d. If voltage being applied on positions 1, 2, and 3 checks out okay, then the relay should be replaced. Coil is probably defective.

**BB. If heat relay does close:**

1. Check power supply at terminal board #2 between terminals #5 and #7; it should be approximately 208-230V.
2. Check power at position 4; there should be no voltage.
3. Check position 5; voltage should be approximately 120V to ground.
4. Check power at position 6; voltage should be 208-230V approximately; if not, check wires for breaks and bad connections.
5. Temperature should rise as explained in AA1 and amperages may be checked according to those instructions. Replace any defective elements.

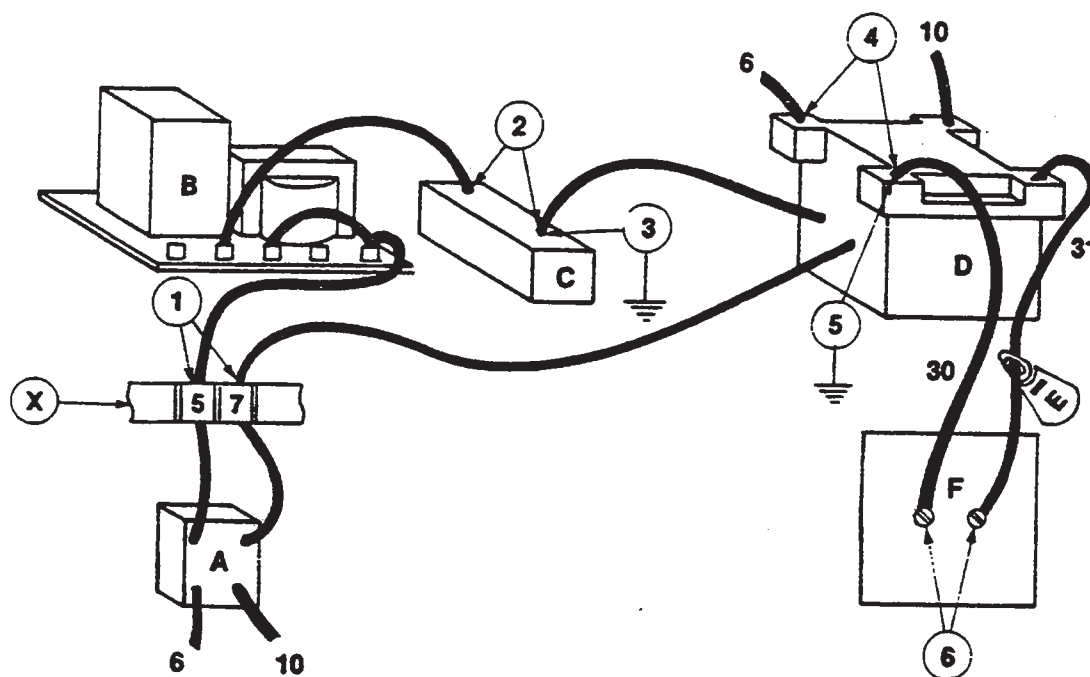

**FIGURE NO. 2 WASH HEATER SYSTEM**

**A. POWER SWITCH  
B. WATER LEVEL CONTROL  
C. THERMOSTAT**

**D. HEATER RELAY  
E. AMPROBE TEST POSITION  
F. WASH TANK HEATER**

**X. TERMINAL BOARD (9 TERMINALS)**

# REPLACING SEAL and CERAMIC on WASH PUMPS

## FUNCTION

The pump is part of the total motor-pump system and utilizes one shaft seal and ceramic to prevent the pump from leaking around the impeller and shaft. One gasket is used to prevent leakage between the pump mounting plate and the machine pump plate.

## REPLACEMENT OF SEAL AND/OR CERAMIC

1. Remove the power source to the machine by turning the circuit breaker to its "off" position on the side of the power unit box.
  2. Drain the machine by removing the overflow strainer in the wash tank.
  3. Support the motor—remove the four nuts holding the pump/motor to the machine's pump plate.
  4. Carefully pull motor outward, move from side to side as required to remove from machine.
  5. Set motor and pump on a sturdy stand close to machine or remove wires and conduit to allow motor/pump to be moved to a better work station.
  6. Insert a firm object into the blades of the fan and use a  $\frac{5}{16}$ " ratchet to remove bolt holding impeller. After the bolt is removed, pull the impeller up and off of the shaft.
  7. The ceramic is embedded in the pump mounting plate and usually does not need replacement, but the seal normally would when water leaks around the motor shaft area. If replacement of either is required, proceed as follows:
    - a. Remove the four bolts holding the pump mounting plate to the motor.
    - b. Slide the mounting plate up and off of the shaft and motor. The embedded ceramic and shaft seal will be removed with the mounting plate.
    - c. Turn over the plate and push the seal and/or ceramic out of the housing carefully. It may be necessary to break the ceramic to remove it.
    - d. Clean the hole where the ceramic was installed.
    - e. Lightly coat with a lubricant around the new ceramic's edges and "O" ring. Gently press the ceramic into place against the snap ring in the housing. Make sure that the grooved side of the ceramic faces the motor and housing snap ring, leaving the smooth side toward the impeller.
    - f. Make sure that the woodruff key is in place in the shaft and then set the plate back on the motor over the shaft.
- NOTE:** A field tool can be made (to ease installation of seal) from a pipe or tube ( $\frac{3}{4}$ " CPVC typical example) that has proper outside and inside dimensions. It must fit over step down in shaft, but be close to larger shaft size on outside. To accommodate woodruff, cut long slot in tube. Lubricate tube slip seal over tube onto shaft.
- g. Lightly coat with a lubricant the new seal face, and gently press it into place over the shaft with the seal face against the ceramic. SEE NOTE ABOVE.
  - h. Place the spring over the shaft with the metal cap up. Press the impeller down onto the shaft, aligning the keyway of the impeller with the woodruff key.
  - i. Tighten the impeller washer, lockwasher, and bolt into place. Replace the four bolts that hold the mounting plate to the motor.
8. Reinstall the pump and motor in the unit by reversing steps one through eight (it is suggested that a new pump gasket be installed).

## IMPELLER ROTATION:

WHEN FACING THE IMPELLER AFTER MOUNTING IT ON THE MOTOR SHAFT, THE IMPELLER SHOULD TURN IN A CCW DIRECTION.

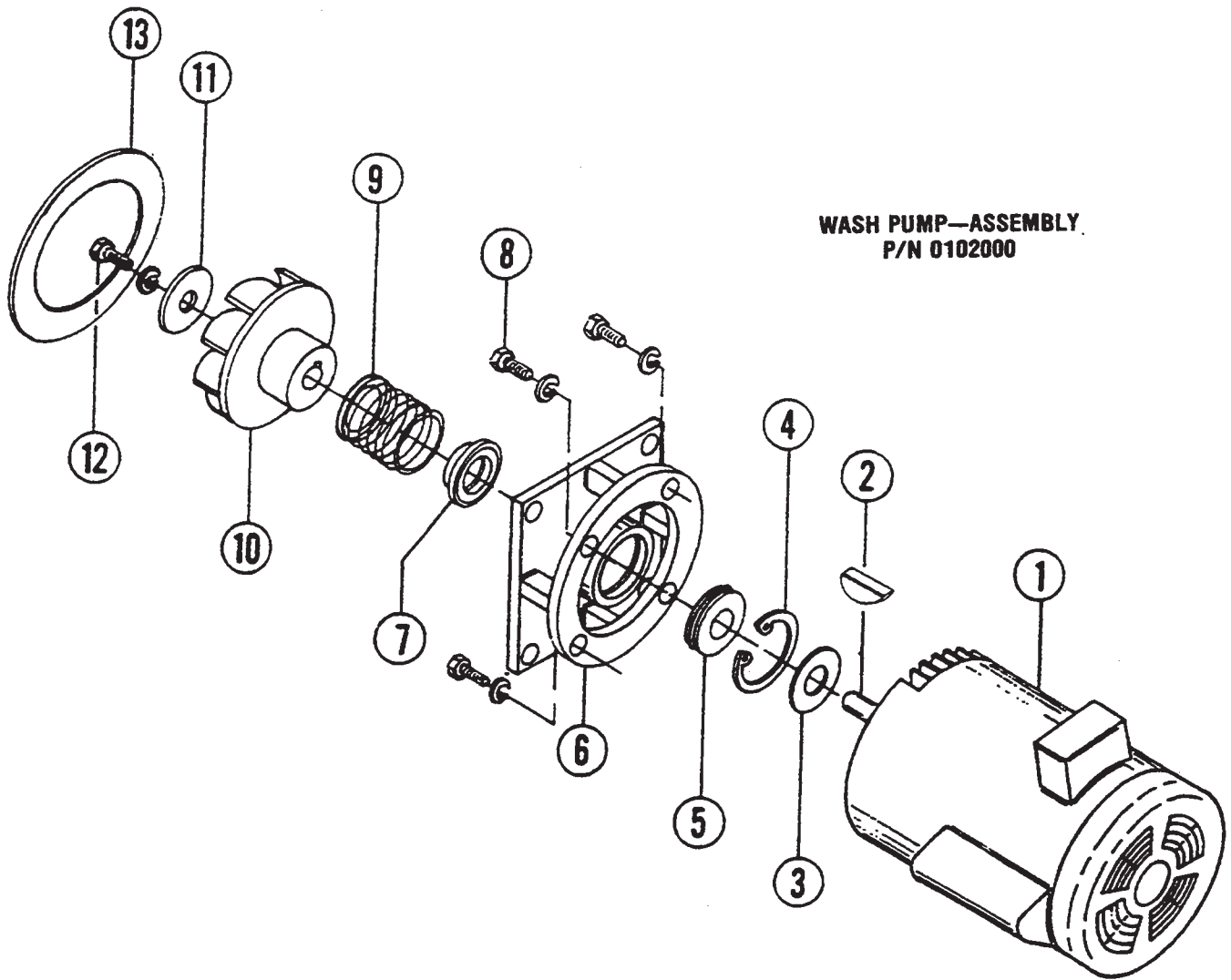

**WASH PUMP—ASSEMBLY  
P/N 0102000**

ITEM	P/N	DESCRIPTION
1	0102700	PUMP MOTOR
2	0106500	WOODRUFF KEY
3	3691300	WASHER, RUBBER
4	0108000	SNAP RING
5	0105000	CERAMIC FACE w/"O" RING
6	0104500	PUMP MOUNTING PLATE
7	0105000	SEAL FACE
8		PLATE TO MOTOR MOUNTING BOLTS & LOCKWASHERS
9	0105000	SEAL ASSEMBLY (SEAL SPRING & CUP WASHER)
10	0105500	PUMP IMPELLER
11	0107500	IMPELLER WASHER
12	0107000	IMPELLER BOLT & LOCKWASHER
13	0106000	PUMP MOUNTING GASKET

# REPLACING SEAL and CERAMIC on RINSE PUMPS

## FUNCTION

The pump is part of the total motor-pump system and utilizes one seal and ceramic to prevent the pump from leaking around the impeller and shaft. One gasket is used to prevent leakage in between the pump mounting plate and the machine pump plate.

## REPLACEMENT OF SEAL AND/OR CERAMIC

1. Remove power source to machine by turning circuit breaker to its off position on side of power unit box.
2. Drain machine by removing overflow strainer in wash tank.
3. Support motor - remove the four nuts holding the pump/motor to the machine's pump plate.
4. Carefully pull motor outward, move from side to side as required to remove from machine.
5. Set motor and pump on a sturdy stand close to machine or remove wires and conduit to allow motor/pump to be moved to a better work station.
6. Remove dust cap over end of motor shaft (opposite impeller end). This can be done by wedging with a screwdriver.
7. Remove impeller - hold shaft by inserting screwdriver in slotted end of shaft and unscrew impeller in counterclockwise direction.
8. The ceramic is embedded in the impeller and normally does not need replacement, but it should be checked for cracks or a worn out surface. If ceramic does need replacement, proceed as follows.
  - (a) With a pointed, flat tool, work the ceramic and rubber cup out of groove in impeller.
  - (b) Clean groove of all residue.
  - (c) Apply small amount of adhesive in groove.
  - (d) Press new ceramic gently into groove with rubber cup leading the way. (NOTE: THE CERAMIC HAS ONE SIDE THAT IS GROOVED. THIS SIDE SHOULD BE FACING DOWN INTO THE RUBBER CUP. THE SMOOTH SURFACE SHOULD BE FACING UP.)
9. The seal is embedded in the pump mounting plate and usually will need replacement when water leaks around motor shaft area. If replacement is required, proceed as follows.
  - (a) Remove four bolts holding pump mounting plate to motor, must be done with Allen wrench.
  - (b) Slide mounting plate up off of shaft and motor.
  - (c) Press seal out of housing carefully.
  - (d) Clean hole where seal was installed.
  - (e) Apply a small amount of non-hardening sealant to back side of seal. Insert new seal with a seal driver to prevent ruffling the edges of seal. Never use screwdriver or similar tool to alternately force edge of seal in place.
10. Reassemble pump and motor by reversing the above procedure.



**PUMP & MOTOR ASSEMBLY  
P/N 0085000**

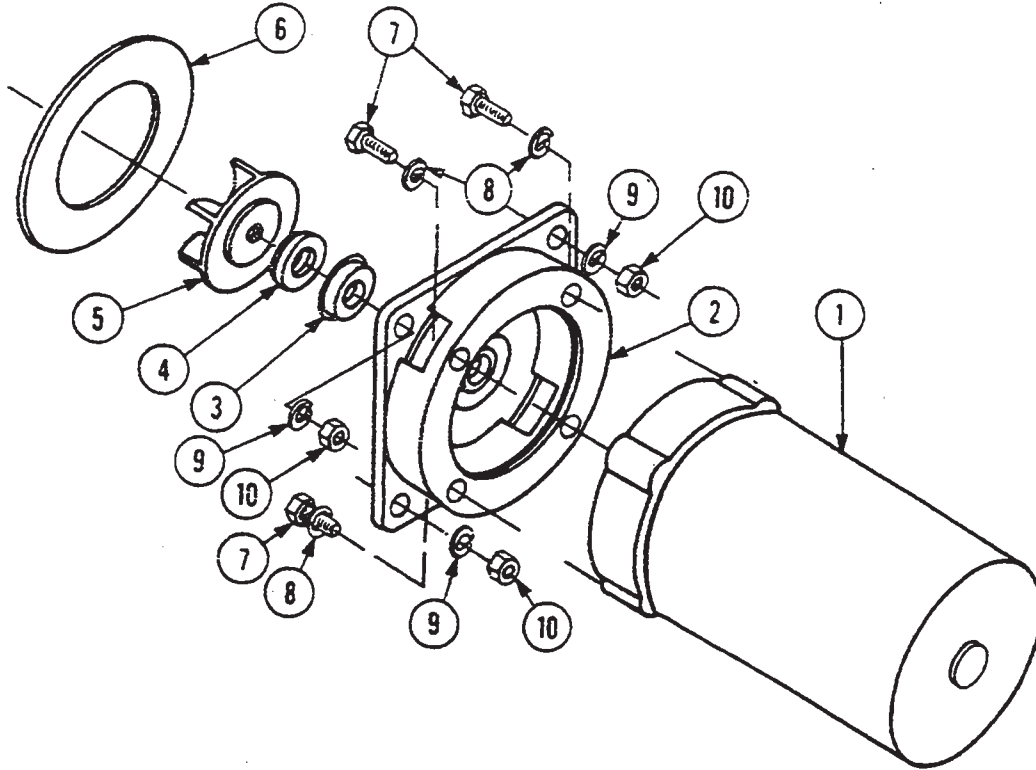

ITEM	P/N	DESCRIPTION
1	0086000	PUMP MOTOR
2	0088000	PUMP MOUNTING PLATE
3	0089000	PUMP CERAMIC FACE W/RETAINER CUP
4	0087500	PUMP IMPELLER SEAL
5	0089500	PUMP IMPELLER
6	0090000	PUMP MOUNTING GASKET

ITEM	P/N	DESCRIPTION
7	0090500	PUMP PLATE TO MOTOR MOUNTING BOLTS
8	0091000	MOUNTING PLATE LOCKWASHERS
9	0091000	PUMP MOUNTING PLATE TO BASE LOCKWASHERS
10	0091500	PUMP MOUNTING PLATE TO BASE NUTS

# INSTRUCTIONS for ADJUSTING TENSION of CANTILEVER

**PROBLEM:** Doors raise hard, but lower easily.

- SOLUTION:**
1. Back off (loosen) upper adjusting nuts (F) on both eyebolts (E) about two or three complete turns.
  2. Tighten lower adjusting nuts (G) on both eyebolts (E) a complete turn.
  3. Check door for easy operation. Adjust further, if necessary.
  4. When adjustment is completed, tighten upper adjusting nuts (F) down against angle to lock in position. Check both eyebolts.

**PROBLEM:** Doors raise easily, but lower hard.

- SOLUTION:**
1. Back off lower adjusting nuts (G) carefully, making sure there is still some thread on eyebolt available (both eyebolts).
  2. Check door for easy operation. Adjust further, if necessary.
  3. When adjustment is complete, tighten upper adjusting nuts (F) down against angle to lock in position. Check both eyebolts.

**PROBLEM:** Doors sticking, or are hard to move up and down.

- SOLUTION:**
1. Raise doors.
  2. Clean inside door channels on machine with a good cleaning compound. It may be necessary to remove doors to completely clean channel. If so, remove only one door at a time. Make sure cantilever has stop to prevent pulling other door up and out of channel. If it does not have stop, secure cantilever arm to machine with doors in the closed position.
  3. Build-up should be completely removed so it may be necessary to use an abrasive pad (non-metallic) to clean.
  4. While you have the door out of channel, make sure it is not dented or crooked. If channel is crooked or dented, use ½" wide block to spread to proper opening.
  5. Clean nylatron runners on the doors or replace nylatron, if excessively worn. See instructions on door runners.
  6. Check door channels on machine for evenness and burrs.
  7. After replacing doors, check for proper operation by raising and lowering with cantilever.

**PROBLEM:** One side of door higher than other and does not close completely.

- SOLUTION:**
1. Straighten cantilever arm.
  2. This can sometimes be accomplished while arm is on machine by forcing down on the arm connected to the high door while the other side of the cantilever is pulled up.
  3. If step two cannot be accomplished on machine, cantilever will have to be removed and straightened.

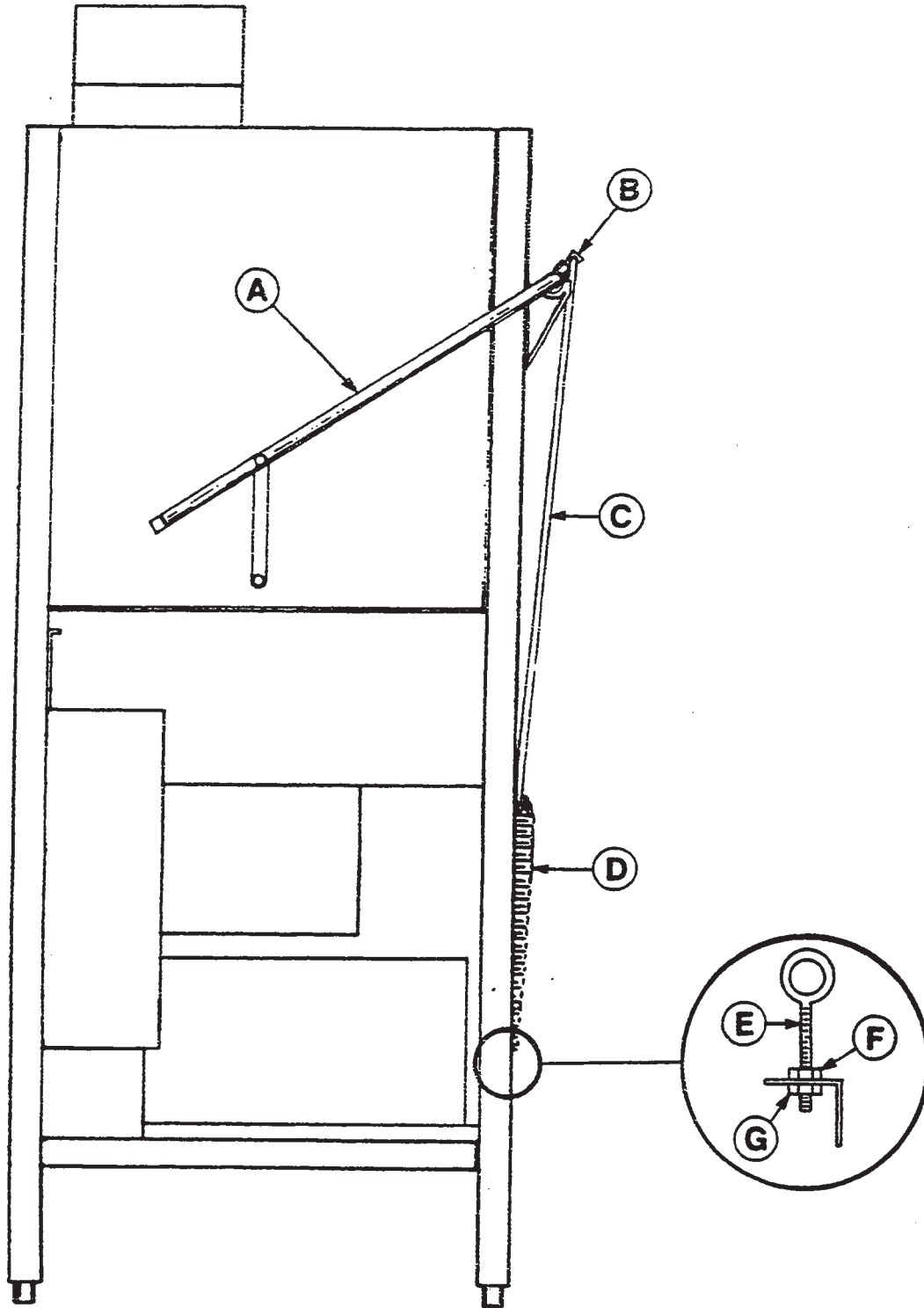

# APPLYING NYLATRON STRIP TO 150 SERIES DOOR

P/N 0051800

## INSTRUCTIONS FOR INSTALLING NEW DOOR GUIDES

IT'S IMPORTANT WHEN REMOVING THE OLD DOOR GUIDES THAT THE SURFACE BE CLEANED THOROUGHLY. THIS CAN BE DONE WITH A SOLVENT THAT WILL DISSOLVE THE REMAINING GLUE AND/OR THE USE OF A FINE SANDPAPER TO SCRATCH THE SURFACE WHERE THE DOOR GUIDE WOULD MAKE CONTACT WITH THE STAINLESS STEEL DOOR.

AFTER THIS IS ACCOMPLISHED AND YOU ARE QUITE CONVINCED THAT THE SURFACE IS CLEANED OF ALL OIL, GLUE, DIRT, DETERGENT, ETC., THEN THE DOOR GUIDE SHOULD BE PLACED ON A FLAT SURFACE AND A BEAD OF A SILICONE ADHESIVE OR ANY GOOD NON-HARDENING GLUE SHOULD BE LAID ON THE INSIDE OF THE DOOR GUIDE'S SURFACE (TOP AND BOTTOM, MAKING SURE THAT NONE OF THE EXPOSED SURFACE TO THE OUTSIDE HAS ANY GLUE ON IT).

TAKE THE DOOR GUIDE AND SNAP IT OVER THE DOOR'S EDGE AS DESCRIBED IN THE ATTACHED SKETCH. DO NOT SLIDE UP THE EDGE. LET THIS DOOR SET FOR AT LEAST ONE HOUR BEFORE USE SO THAT THE GLUE OR ADHESIVE HAS A CHANCE TO SET SOMEWHAT.

IF THESE INSTRUCTIONS ARE FOLLOWED, THE DOOR GUIDES SHOULD ADHERE TO THE DOOR.

**Fig. 1 - PUT A STREAM OF SILASTIC OR NON-HARDENING ADHESIVE IN INSIDE CORNER OF STRIP.**

**Fig. 2 - SIDE VIEW OF NYLATRON STRIP.**

**Fig. 3 - SNAP STRIP ON DOOR LIP.**

**NOTE: DO NOT SLIDE STRIP FROM END; ALWAYS SNAP ON.**

**Fig. 4 - PRESS DOWN WITH THUMB AND INWARD WITH FINGERS.**

**Fig. 5 - FINISHED APPLICATION - END VIEW.**

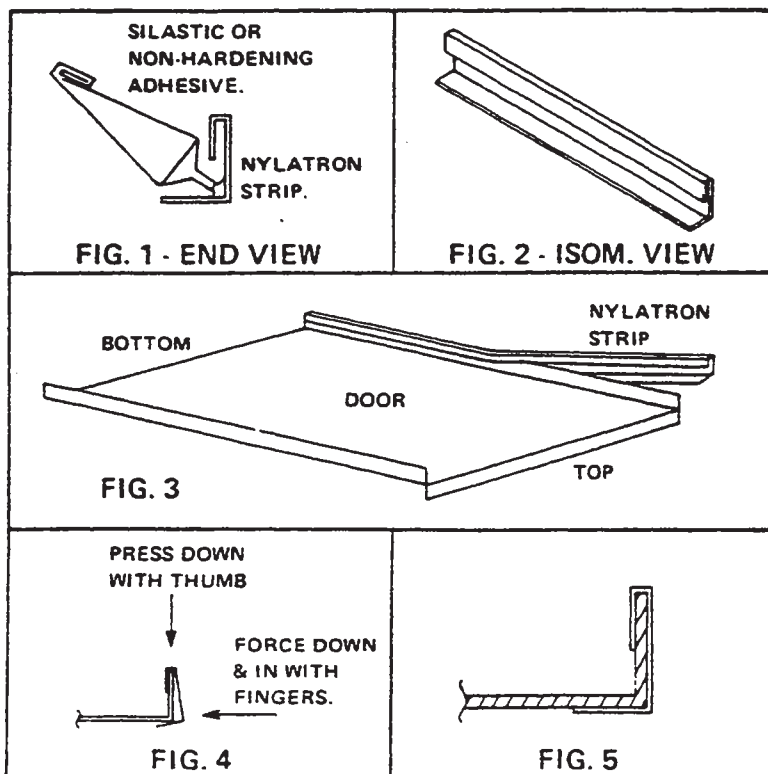

# WATER LEVEL CONTROL (ELS)

(FOR RINSE TANK) P/N 0205000

## FUNCTION

The Water Level Control device utilized on power rinse (PRB) models only, automatically maintains the water level in the rinse tank. The rinse tank water level control is energized by the power switch. The control is designed to sense when the proper water level is maintained. At this time, the relay in the clear plastic case will activate, opening the normally closed circuit to the solenoid, which stops the water flow to the rinse tank.

When water is removed from the tank by the rinse pump, the sensing probe will alert the water level control by signal to deactivate and return the contact points on relay (in clear plastic case) to the normally closed position, allowing power to be reapplied to the solenoid valve. Water will again flow into rinse tank until proper level is reached and maintained.

## CHECKOUT

**NOTE: ALL ELECTRICAL CHECKS SHOULD BE MADE BY QUALIFIED SERVICE PERSONNEL OR ELECTRICIAN.**

If one of the following problems exist, this control should be checked out as shown below:

1. Water to rinse tank runs continually with the power switch on.
2. Water does not flow into rinse tank when required.

## PROCEED WITH CHECKOUTS:

1. Remove power source to machine by moving breaker to "off" position.
2. Remove 2 screws holding cover on power unit box and remove cover.
3. Locate the water level control for the rinse tank circuit (sketch below). Remove, mark, and insulate for easy replacement wires going to letters C and H on control.
4. Reapply power and turn on power switch.
5. With insulated wire, connect jumper wire between terminals C and H (24 Volt system).
6. If relay (inside clear plastic case marked "X" on drawing below) operates, then the water level control action can be deemed operational, and other causes should be explored (see trouble shooting section).
7. If relay doesn't operate, then check relay coil continuity. Replace relay or complete control, as necessary.
8. Remove power source once again and replace wires removed in (3) to original terminals or new control, if replacement was made.

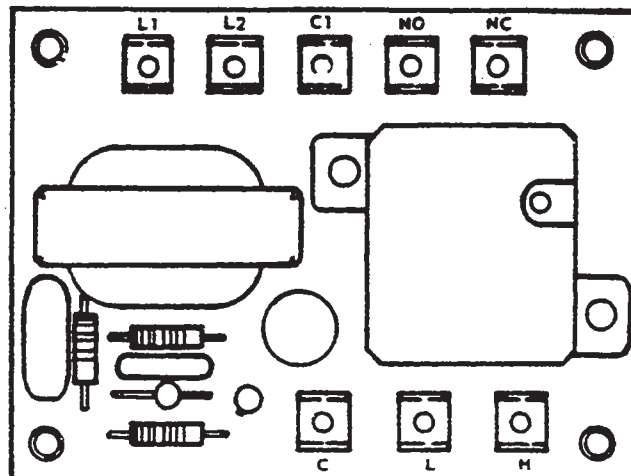

# **WATER LEVEL CONTROL (ELS)**

**(INITIAL FILL AND HEAT CIRCUITS) P/N 0205000**

## **FUNCTION**

This control is activated when the power switch is turned on. The primary function is to automatically control the proper initial filling of the wash tank, then to activate the wash and rinse tank heat circuit. It will also provide cutoff of the wash and rinse heat circuit, should the water be accidentally drained from the machine (with the power switch still on). The power switch should always be turned off before draining.

This water level control is used in conjunction with two probes (sensors), power switch, fill switch, rinse relay, thermostat(s), heat relay(s), solenoid or rinse motor.

When the power switch is turned on, the normally closed circuit in the plug-in relay is energized. As the fill switch is depressed and released, the rinse relay contacts close, and the solenoid (or rinse pump on PRB model) opens and water flows into wash tub. As the water rises in the wash tub, it will cover first the lower probe (directly above wash element) then reach the upper probe. At this time, the plug-in relay coil will be activated and open the normally closed contacts, de-energizing the solenoid (or rinse pump). Simultaneously, the contacts will close on the normally open circuit, energizing the wash-rinse heat circuit. (Checkout and information concerning that part of the circuit are in the wash heater system or rinse heater system instruction page of this manual.)

If the water should be drained from the machine while the power switch is still on, the lower probe will sense the lack of water and de-energize the plug-in relay, which will de-energize the wash-rinse heat circuit. **DO NOT DEPEND ON THIS—always turn power switch off before draining.**

## **SYMPTOMS OF LEVEL CONTROL FAILURE:**

1. Fill does not take place unless rinse switch is depressed until full.
2. Initial fill does not stop when it reaches overflow, but continues.
3. Wash-rinse heat circuit does not activate.
4. Wash heater remains on (if wash water accidentally emptied with power switch on.)

## **PROCEED WITH CHECKOUT:**

1. Remove power to machine by turning customer circuit breaker to its "off" position. Turn machine circuit breaker, located on right side on power unit box, to "off."
2. Remove 2 screws holding cover on power unit box and remove cover.
3. Locate initial fill and wash-heat circuit water level control board and disconnect wires going to terminals marked C, H, and L. Mark and insulate wires for replacement.
4. Be sure wash tank is empty and power switch is off. Carefully reapply power to machine. Begin by turning power switch on. With an insulated jumper wire, touch jumper between terminals C & H; relay in clear plastic cube should activate as wire is touched to terminals. Observe relay contacts—they should pull in. If they do, remove wire and they should return to original position. Repeat several times to verify action. Reconnect wires removed.

5. If relay operates, the control can be deemed operational and other causes should be explored.

- EXAMPLES:
1. Loose or broken wire to probe or ground (green wire).
  2. Dirty probe(s).
  3. Solenoid faulty (see instruction page concerning solenoid).
  4. Thermostat faulty or needs adjustment (see instruction page concerning thermostat).
  5. Wash element faulty (see instruction page concerning wash-heat checkout).

6. If relay does not operate, check voltage being applied to L1 - L2 marked on control. It should be 208-230V. Replace control, if necessary.

7. In any case, always locate sensor (probes) inside wash tub and clean off all deposits (instruct customer; this should be at least a weekly project).

8. Remove power to machine and replace panel and any wires that were not replaced previously.

# TROUBLE SHOOTING GUIDE

PROBLEM	CAUSE	SOLUTION
Nothing on machine operates.	<ol style="list-style-type: none"> <li>1. No Voltage to dishwasher               <ol style="list-style-type: none"> <li>a. Customer's fuse blown or circuit breaker tripped.</li> </ol> </li> <li>2. Machine circuit breaker tripped or turned off.</li> <li>3. Voltage to machine low or circuit to machine broken.</li> </ol>	<ol style="list-style-type: none"> <li>a. Replace or reset.</li> <li>2. Turn on or reset.</li> <li>3. Contact your electrician and/or power company for repair.</li> </ol>
Will not fill with electrical power applied even though other components work. (B Model)	<ol style="list-style-type: none"> <li>1. Water hand valve off.</li> <li>2. Power switch not on or faulty.</li> <li>3. Fill switch faulty or loose wire connection.</li> <li>4. Solenoid valve does not operate.</li> <li>5. Water level control faulty.</li> <li>6. Y-strainer clogged.</li> </ol>	<ol style="list-style-type: none"> <li>1. Turn hand valve on.</li> <li>2. Turn on or replace.</li> <li>3. Replace switch or wire or connection terminal.</li> <li>4. See instruction page concerning the Solenoid Valve.</li> <li>5. See page on Water Level Control.</li> <li>6. Turn water to machine off, remove plug &amp; strainer screen, clean &amp; replace.</li> </ol>
Will not fill with electrical power applied even though other components work. (PRB Model)	<ol style="list-style-type: none"> <li>1. Customer's water hand valve off.</li> <li>2. Power switch not on or faulty.</li> <li>3. Fill switch faulty or loose wire connection.</li> <li>4. Rinse motor not operating.</li> <li>5. Water level control does not maintain the water level in the rinse tank.</li> <li>6. Solenoid Valve does not operate.</li> <li>7. Y-strainer clogged.</li> </ol>	<ol style="list-style-type: none"> <li>1. Turn hand valve on.</li> <li>2. Turn on or replace.</li> <li>3. Replace switch or wire or connection terminal.</li> <li>4. Check connection and voltage to motor. Repair or replace as necessary.</li> <li>5. See instruction page concerning the Water Level Control for PRB Models.</li> <li>6. See instruction page concerning Solenoid Valve.</li> <li>7. Turn off water to machine, remove plug, prepare to catch hot water &amp; strainer screen, clean &amp; replace.</li> </ol>



# TROUBLE SHOOTING GUIDE

PROBLEM	CAUSE	SOLUTION
Fills slowly and/or rinse is weak.	<ol style="list-style-type: none"> <li>1. Low water pressure.</li> </ol>	<ol style="list-style-type: none"> <li>1. Check water pressure by:               <ol style="list-style-type: none"> <li>a. Turn power switch off.</li> <li>b. Empty wash tub.</li> <li>c. Replace overflow strainer, close doors.</li> <li>d. Turn on power switch.</li> <li>e. As you depress fill switch, time the seconds it takes to fill machine to within ¼" of top of the overflow tube. It should be 60 seconds. Any more than 5 seconds longer indicates the water supply &amp; pressure insufficient.</li> </ol> </li> </ol>
Rinse water runs continuously with power on.	<ol style="list-style-type: none"> <li>2. Rinse head assemblies limed up or clogged with other deposits.</li> </ol> <ol style="list-style-type: none"> <li>1. Rinse switch sluggish or faulty.</li> <li>2. Solenoid Valve dirty or faulty.</li> <li>3. Water level control faulty (PRB Models only).</li> <li>4. Rinse tank probe coated (PRB Model).</li> <li>5. Breather tube plugged or bent closed (PRB Model only).</li> </ol>	<ol style="list-style-type: none"> <li>2. Clean rinse head tubes. See instruction page on Preventive Maintenance.</li> </ol> <ol style="list-style-type: none"> <li>1. Replace.</li> <li>2. See special instruction page concerning Solenoid Valve.</li> <li>3. See special instructions page concerning Water Level Control for PRB Models.</li> <li>4. Remove &amp; clean probe, then replace.</li> <li>5. Clean tube or repair.</li> </ol>
Rinse water runs with no electrical power applied to solenoid (power switch off).	<ol style="list-style-type: none"> <li>1. Water pressure excessive.</li> </ol> <ol style="list-style-type: none"> <li>2. Solenoid Valve diaphragm breather hole clogged.</li> </ol>	<ol style="list-style-type: none"> <li>1. Check using pressure gauge during flow period (solenoid valve open) should read 20 PSI, if in excess installation of a Pressure Reducer can reduce pressure.</li> <li>2. See instruction page concerning Solenoid Valve.</li> </ol>

# TROUBLE SHOOTING GUIDE

PROBLEM	CAUSE	SOLUTION
<p>Machine won't work on automatic. Wash and rinse work only on manual.</p>	<ol style="list-style-type: none"> <li>1. Timer motor faulty.</li> <li>2. Power switch faulty.</li> <li>3. Cycle switch in manual (left-hand) position.</li> </ol>	<ol style="list-style-type: none"> <li>1. Remove control box covers and observe timer operation. See instruction page for Changing Timer Motor.</li> <li>2. Replace switch.</li> <li>3. Position switch in center position and depress start.</li> </ol>
<p>Machine will not automatically fill.</p>	<ol style="list-style-type: none"> <li>1. Power is off.</li> <li>2. Wire loose or broken to L1 and L2.</li> <li>3. Power switch faulty.</li> <li>4. Water level control faulty.</li> <li>5. High fill probe.</li> <li>6. Electric solenoid valve not opening.</li> </ol>	<ol style="list-style-type: none"> <li>1. Check incoming line fuses circuit breakers.</li> <li>2. Check line voltage at L1 and L2 on water level control and control panel.</li> <li>3. Replace.</li> <li>4. To check water level control, see special instructions on Water Level Control.</li> <li>5. Clean or short out probe end to tank; this will cause the relay on the water level control to close and return. If this does not happen, check for loose wire especially a loose ground wire.</li> <li>6. Check electric solenoid valve, see special information section under Solenoid Valve.</li> </ol>
<p>Wash motor does not operate on automatic or manual, but machine rinses properly.</p>	<ol style="list-style-type: none"> <li>1. Broken or loose wire from terminal board to motor.</li> <li>2. Wash motor faulty.</li> </ol>	<ol style="list-style-type: none"> <li>1. Check for loose or broken short circuit.</li> <li>2. Repair or replace.</li> </ol>

# TROUBLE SHOOTING GUIDE

PROBLEM	CAUSE	SOLUTION
<p>Wash motor does not operate on automatic, but rinses on automatic and washes on manual.</p>	<ol style="list-style-type: none"> <li>1. Wash micro switch in timer faulty.</li> </ol>	<ol style="list-style-type: none"> <li>1. Check timer, see instruction page on Timer.</li> </ol>
<p>Machine begins to wash when power switch is turned on without operating start switch.</p>	<ol style="list-style-type: none"> <li>1. Timer motor, micro switch faulty.</li> <li>2. Start switch faulty.</li> <li>3. Cycle relay faulty.</li> </ol>	<ol style="list-style-type: none"> <li>1. Check timer, see instruction page on Timer.</li> <li>2. Replace.</li> <li>3. Replace.</li> </ol>
<p>Machine goes through entire cycle and shuts off but washes through complete cycle.</p>	<ol style="list-style-type: none"> <li>1. Wash micro switch faulty.</li> </ol>	<ol style="list-style-type: none"> <li>1. Check timer, see instruction page on Timer.</li> </ol>
<p>Wash reservoir does not remain full.</p>	<ol style="list-style-type: none"> <li>1. Large overflow strainer not properly seated.</li> <li>2. Bottom of strainer (conical end of tube) bent out of shape.</li> <li>3. Dirt or mineral deposits in strainer hole.</li> </ol>	<ol style="list-style-type: none"> <li>1. Check 'O' ring in drain fitting - Put strainer in tightly.</li> <li>2. Replace strainer.</li> <li>3. See instruction page on Preventive Maintenance.</li> </ol>
<p>Wash motor runs, but machine fails to wash satisfactorily.</p>	<ol style="list-style-type: none"> <li>1. Wash temperature of 150°-160° is not maintained.</li> <li>2. Inadequate or improper detergent being used.</li> <li>3. Pump intake strainer is dirty.</li> <li>4. Wash tubes not turning.</li> </ol>	<ol style="list-style-type: none"> <li>1. Adjust thermostat on wash tank, check wash heater element.</li> <li>2. Use recommended detergent, see Machine's Operation instructions.</li> <li>3. See Preventive Maintenance.</li> <li>4. The wash assembly can usually be freed by bearing down on the wash assembly and rotating back and forth. If the assembly can't be freed in this manner, take the wash assembly apart and the bearing races, using care not to lose the bearings or drop them into the machine. Clean scale off part with recommended scale solvent. See Preventive Maintenance &amp; instruction for Removal of Wash Head Assemblies.</li> </ol>

# TROUBLE SHOOTING GUIDE

PROBLEM	CAUSE	SOLUTION
Wash Pump leaks.	<ol style="list-style-type: none"> <li>1. Impeller seal is worn (leaks around shaft).</li> <li>2. Pump assembly is not seated to base of machine (leaks around mounting plate).</li> </ol>	<ol style="list-style-type: none"> <li>1. Remove and inspect pump and motor assembly, see instruction page on Pump Seals and Ceramic Replacement.</li> <li>2. Replace gasket. Make sure mounting nuts are tight.</li> </ol>
Rinse and fill switch is on, but water does not come through rinse tubes.	<ol style="list-style-type: none"> <li>1. Valve in water line is not open.</li> <li>2. Rinse tubes are clogged.</li> <li>3. Strainer in water line is full of scale.</li> <li>4. Rinse and fill switch faulty.</li> <li>5. Electric solenoid diaphragm or plunger not operating.</li> <li>6. Coil on the solenoid valve is burned out.</li> <li>7. Insufficient or excessive pressure.</li> </ol>	<ol style="list-style-type: none"> <li>1. Check to make sure all valves are open.</li> <li>2. See Preventive Maintenance.</li> <li>3. See Preventive Maintenance.</li> <li>4. Check rinse and fill switch.</li> <li>5. Remove diaphragm and plunger, flush and clean, see instruction page on Solenoid Valves.</li> <li>6. See #5 above.</li> <li>7. Check flow pressure which should not exceed 25 PSI or go below 15 PSI.</li> </ol>
When power switch is on, rinse runs continually.	<ol style="list-style-type: none"> <li>1. Water level control faulty.</li> </ol>	<ol style="list-style-type: none"> <li>1. Check instruction page on water level controls.</li> </ol>
Machine goes through entire cycle and shuts off, but rinses throughout the cycle.	<ol style="list-style-type: none"> <li>1. Defective rinse micro switch.</li> </ol>	<ol style="list-style-type: none"> <li>1. Check Timer instruction page.</li> </ol>
Power switch off, rinse runs continually as soon as power is applied to machine.	<ol style="list-style-type: none"> <li>1. Power &amp; rinse switch faulty.</li> <li>2. Loose green ground wire from water level control.</li> </ol>	<ol style="list-style-type: none"> <li>1. Replace rinse and/or power switch.</li> <li>2. Tighten ground wire or see instruction page on Solenoids.</li> </ol>
Extremely high rinse temperature indication.	<ol style="list-style-type: none"> <li>1. Thermostat set too high.</li> <li>2. Thermostat faulty.</li> </ol>	<ol style="list-style-type: none"> <li>1. Adjust thermostat control, see instruction page on Thermostat.</li> <li>2. Replace.</li> </ol>

# TROUBLE SHOOTING GUIDE

PROBLEM	CAUSE	SOLUTION
<p>Low rinse temperature indication.</p>	<ol style="list-style-type: none"> <li>1. Machine using more water than normal by rinse running throughout wash cycle, caused by faulty rinse micro switch in timer.</li> <li>2. Incoming water supply not hot enough.</li> <li>3. Power switch faulty.</li> <li>4. Setting on thermostat control has been moved from original factory setting.</li> <li>5. Thermostat faulty.</li> <li>6. Heater faulty.</li> <li>7. Contactor faulty.</li> <li>8. Thermometer faulty.</li> </ol>	<ol style="list-style-type: none"> <li>1. If this trouble occurs, it should be determined that the rinse is running during the wash cycle by inspecting the rinse solenoid and by disconnecting the wash motor lead at the terminal board on the control panel. See instruction page on Timer.</li> <li>2. Provide adequate supply of hot water, see specifications sheet.</li> <li>3. Check power switch.</li> <li>4. Try new setting. Move the thermostat control counter-clockwise for higher setting.</li> <li>5. Check thermostat, see instruction page.</li> <li>6. Check heater, see instruction page.</li> <li>7. Check contactor, see instruction page.</li> <li>8. Remove thermometer and check in hot water against an accurate thermometer.</li> </ol>
<p>Water leaks from top of door.</p>	<ol style="list-style-type: none"> <li>1. Spray arms are not moving freely or ends bent downward.</li> </ol>	<ol style="list-style-type: none"> <li>1. See instruction page on preventive maintenance - pull upward on ends of longest wash spray arms ½".</li> </ol>
<p>Machine wash and rinse do not operate.</p>	<ol style="list-style-type: none"> <li>1. Timer defective and stopped in timed cycle.</li> </ol>	<ol style="list-style-type: none"> <li>1. Move cycle switch to left-hand position (cycle switch is three position) RIGHT - Start, CENTER - Auto, LEFT - Manual. See instruction page on Timer.</li> </ol>
<p>Machine does not operate at all.</p>	<ol style="list-style-type: none"> <li>1. Circuit breaker tripped.</li> </ol>	<ol style="list-style-type: none"> <li>1. Reset circuit breaker on wall panel. Check voltage to machine at 6 and 10 at terminal board #TB2.</li> </ol>

# TROUBLE SHOOTING GUIDE

PROBLEM	CAUSE	SOLUTION
Rinse pump leaks. PRB Models only.	<ol style="list-style-type: none"> <li>1. Impeller seal is worn.</li> <li>2. Impeller ceramic is worn or scored.</li> </ol>	<ol style="list-style-type: none"> <li>1. See instruction page on Ceramic Replacement.</li> <li>2. Same as 1.</li> </ol>
Indicator light(s) does not glow at any time.	<ol style="list-style-type: none"> <li>1. Light(s) faulty or poor connection.</li> </ol>	<ol style="list-style-type: none"> <li>1. Replace or correct connection.</li> </ol>
None of the automatic functions work (wash, rinse).	<ol style="list-style-type: none"> <li>1. Start switch faulty.</li> <li>2. Wire connections poor.</li> <li>3. Timer rinse or wash micro switch faulty.</li> </ol>	<ol style="list-style-type: none"> <li>1. Check switch. Replace if necessary, see instructions page concerning Replacement of Switches in Control Panel.</li> <li>2. Correct connections.</li> <li>3. See instruction page concerning Timer &amp; Motor.</li> </ol>
Vacuum breaker leaks.	<ol style="list-style-type: none"> <li>1. Limed up.</li> <li>2. Faulty.</li> </ol>	<ol style="list-style-type: none"> <li>1. Disassemble:               <ol style="list-style-type: none"> <li>a. Remove top using flat jaw wrench or channel locks.</li> <li>b. Remove poppet.</li> <li>c. Clean poppet &amp; V.B. top &amp; body.</li> <li>d. Replace parts removed.</li> </ol> </li> <li>2. Replace needed parts or whole VB.</li> </ol>

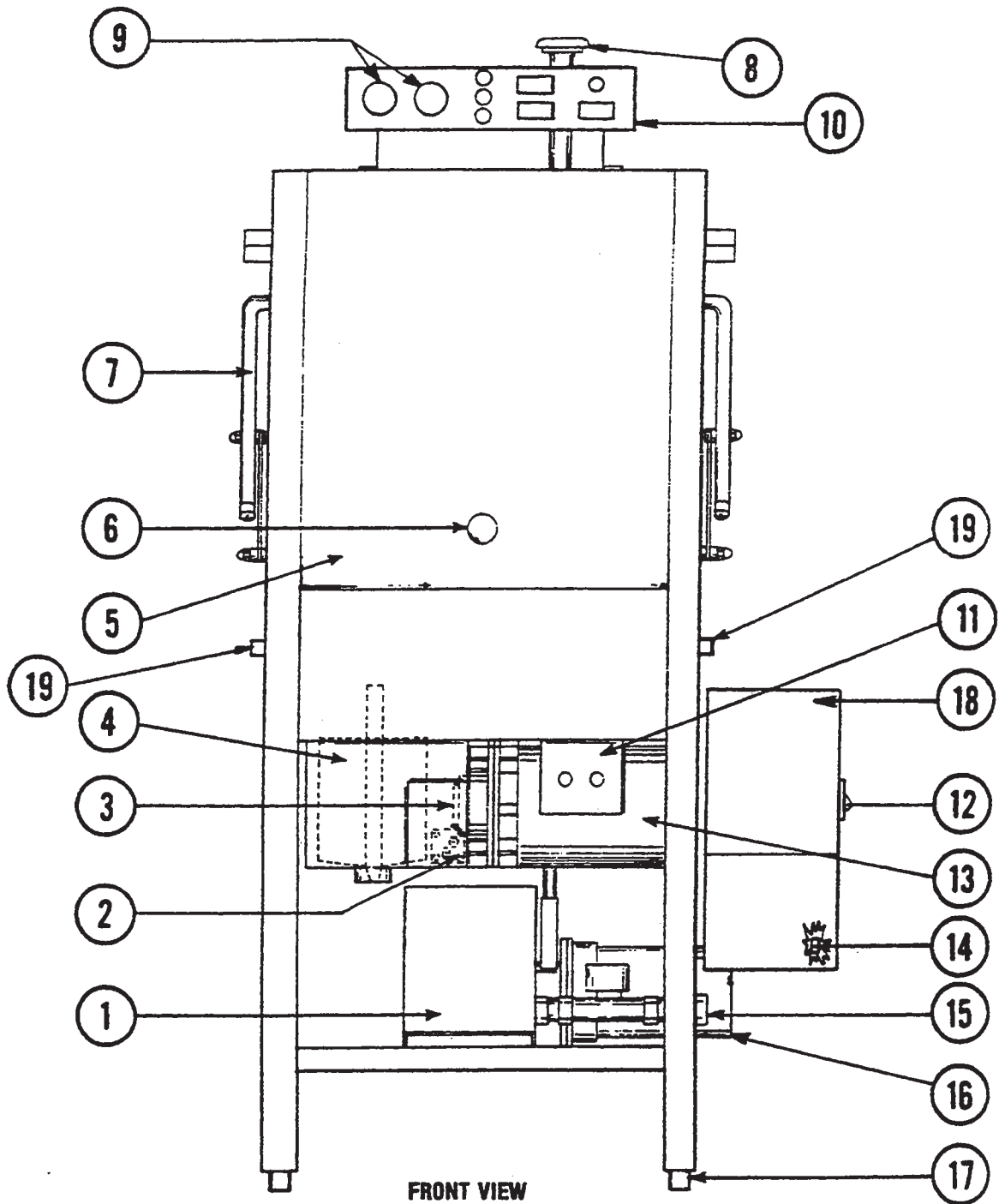

FRONT VIEW  
150PRB

ITEM	P/N	DESCRIPTION	ITEM	P/N	DESCRIPTION
1	0006901	BOOSTER TANK	12	0012000	CONTROL CIRCUIT PROTECTION DEVICE
2	0058000	WASH TANK HEATER	13	0102000	WASH PUMP & MOTOR
3	0151000	INSIDE PUMP STRAINER	14	0165500	CUSTOMER'S ELECTRICAL CONNECTION
4	0152000	LARGE OVERFLOW STRAINER	15		CUSTOMER'S WATER CONNECTION
5	0047500	FRONT DOOR	16	0085000	RINSE PUMP & MOTOR (PRB ONLY)
6	0050900	DOOR HANDLE	17	0083300	ADJUSTABLE FOOT
7	0008901	CANTILEVER ARM	18	0030600	POWER BOX B
	0184301	VACUUM BREAKER		0030700	POWER BOX PRB
	0169200	WASH & RINSE THERMOMETERS	19		DETERGENT DISPENSER FITTING
0	0020400	CONTROL BOX & PANEL			
11	0169400	THERMOSTAT BOX			

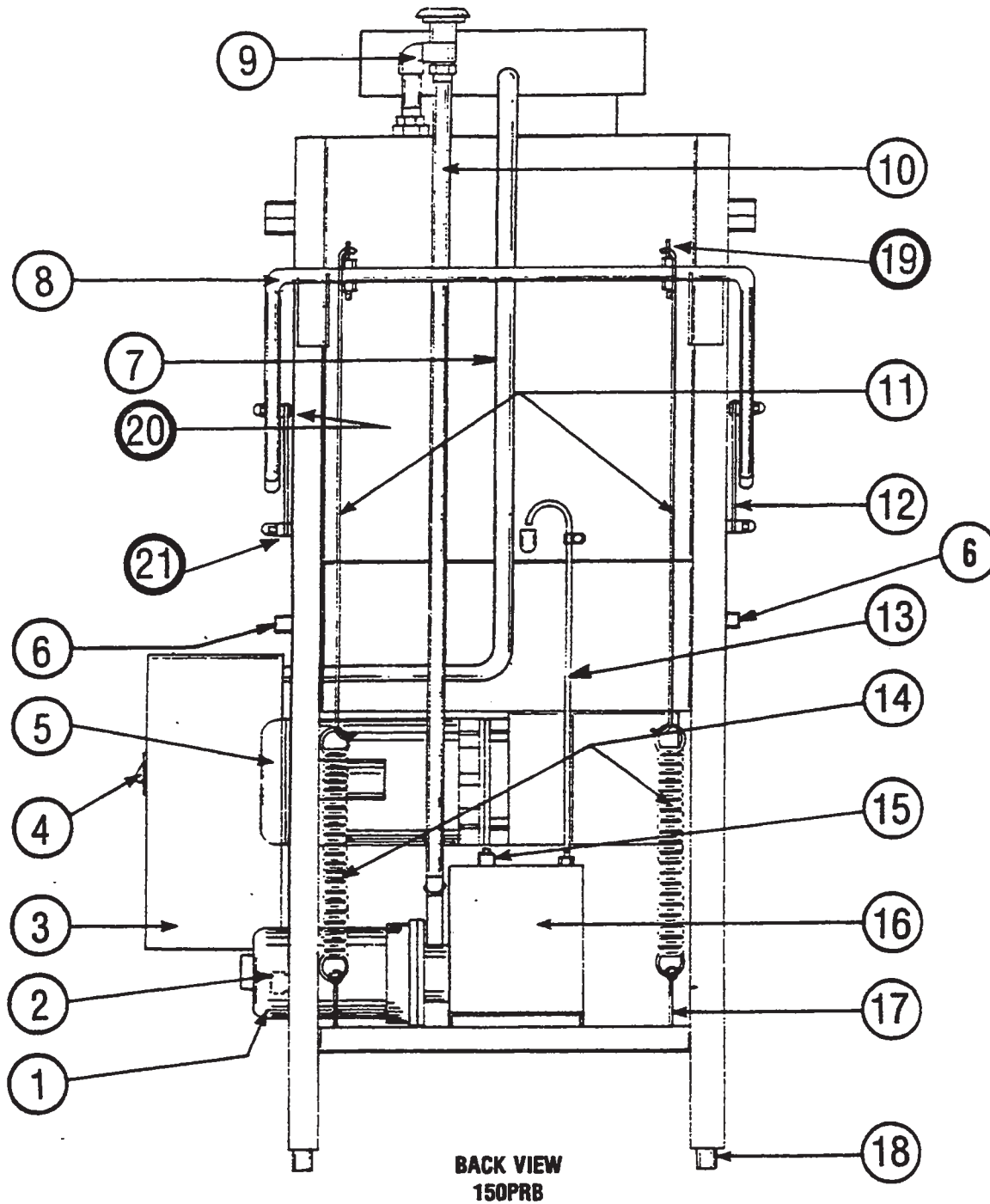

ITEM	P/N	DESCRIPTION	ITEM	P/N	DESCRIPTION
1	0085000	RINSE PUMP & MOTOR (PRB ONLY)	12	0011500	CANTILEVER DOOR COUPLER
2		CUSTOMER'S WATER CONNECTION	13	0007500	BREATHER TUBE (PRB ONLY)
3	0030700	POWER BOX	14	0009000	CANTILEVER SPRING
4	0012000	CONTROL CIRCUIT PROTECTION DEVICE	15	0084500	WATER LEVEL PROBE (PRB ONLY)
5	0102000	WASH PUMP & MOTOR	16	0006901	BOOSTER TANK
6		DETERGENT DISPENSER FITTING	17	0009400	CANTILEVER EYE BOLTS
7		CONTROL BOX CONDUIT	18	0083300	ADJUSTABLE FOOT
8	0008901	CANTILEVER ARM	19	0009100	YOKE ASSEMBLY
9	0184301	VACUUM BREAKER	20	0010000	SLEEVE
10		EXTERNAL VACUUM BREAKER PIPING	21	0049000	SPACER
11	0008700	CANTILEVER SPRING RODS			



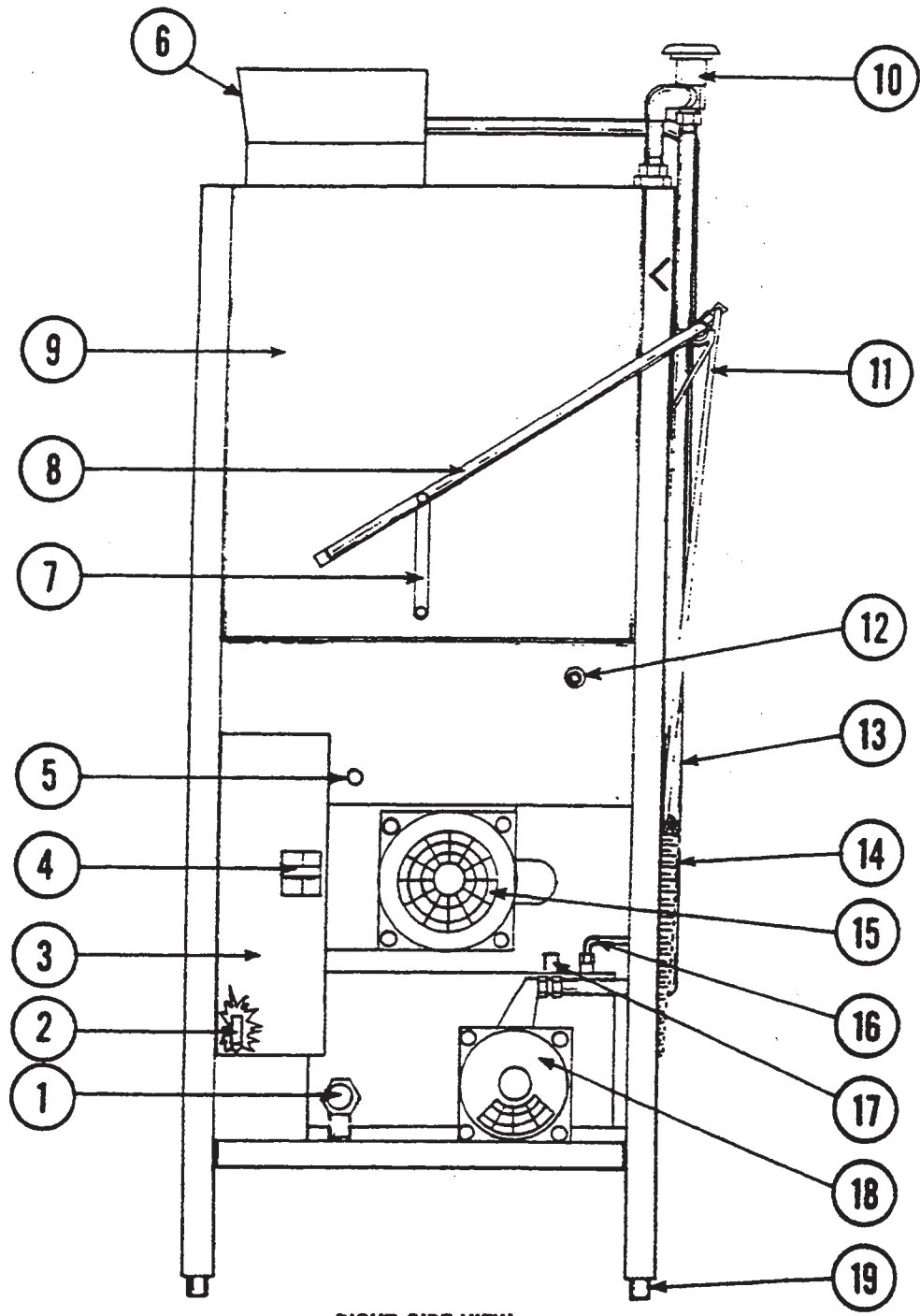

RIGHT SIDE VIEW  
150PRB

ITEM	P/N	DESCRIPTION
1		CUSTOMER'S WATER CONNECTION
2	0165500	CUSTOMER'S ELECTRICAL CONNECTION
3	0030700	POWER BOX
4	0012000	CONTROL CIRCUIT PROTECTION DEVICE
5	0084300	HIGH WATER PROBE
6	0169200	WASH & RINSE THERMOMETERS
7	0011500	CANTILEVER DOOR COUPLER
8	0008901	CANTILEVER ARM
9	0047500	SIDE DOOR
10	0184301	VACUUM BREAKER

ITEM	P/N	DESCRIPTION
11	0008700	CANTILEVER SPRING ROD
12		DETERGENT DISPENSER FITTING
13		EXTERNAL VACUUM BREAKER PIPING
14	0009000	CANTILEVER SPRING
15	0102000	WASH PUMP & MOTOR
16	0007500	BREATHING TUBE (PRB ONLY)
17	0084500	WATER LEVEL PROBE (PRB ONLY)
18	0085000	RINSE PUMP & MOTOR (PRB ONLY)
19	0083300	ADJUSTABLE FOOT

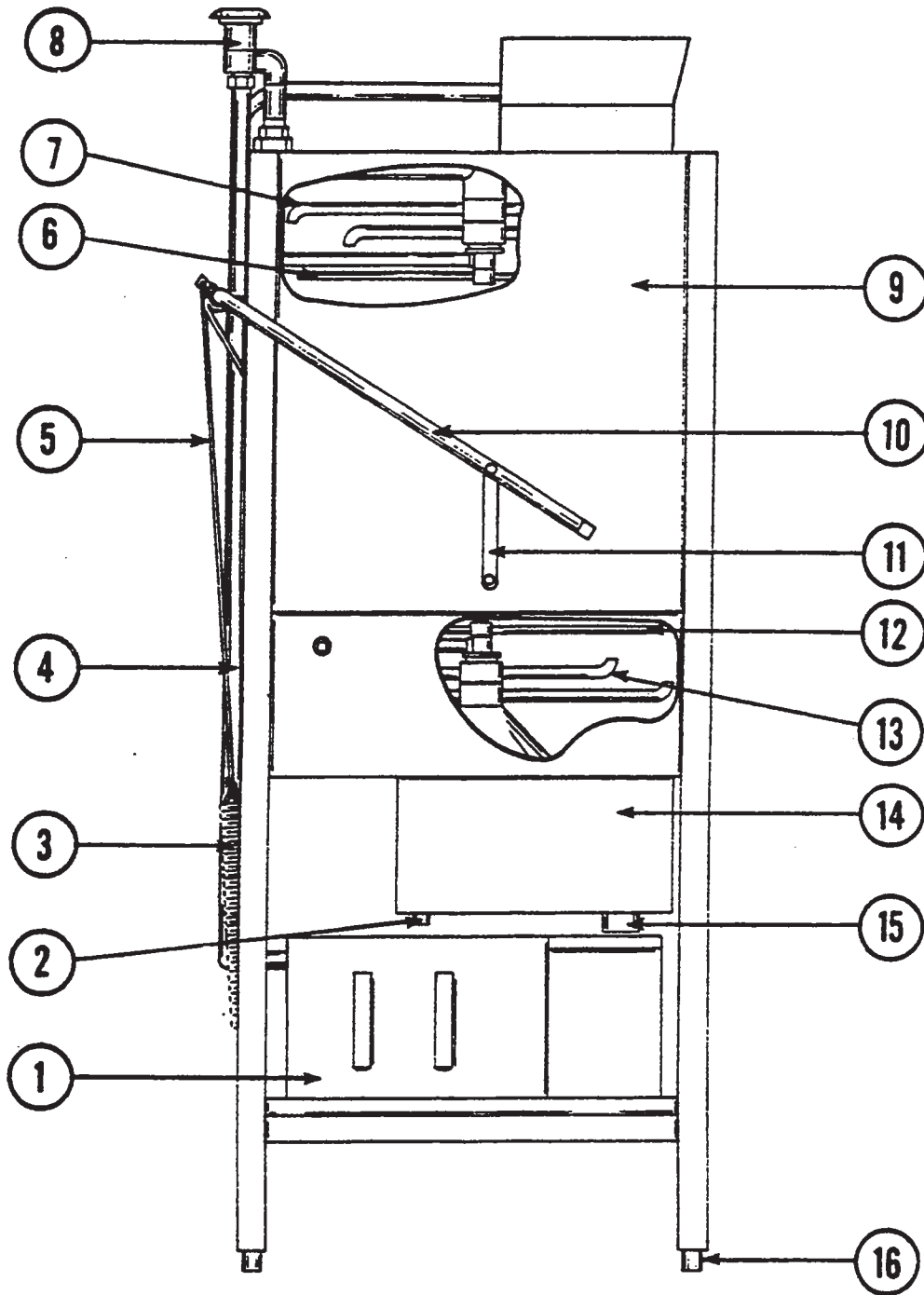

LEFT SIDE VIEW  
150PRB

ITEM	P/N	DESCRIPTION
1	0006901	BOOSTER TANK
2		DETERGENT SENSOR FITTING
3	0009000	CANTILEVER SPRING
4		EXTERNAL VACUUM BREAKER PIPING
5	0008700	CANTILEVER SPRING ROD
6	0136000	UPPER RINSE HEAD ASSEMBLY
7	0200000	UPPER WASH HEAD ASSEMBLY
8	0184300	VACUUM BREAKER

ITEM	P/N	DESCRIPTION
9	0047500	SIDE DOOR
10	0008901	CANTILEVER ARM
11	0011500	CANTILEVER DOOR COUPLER
12	0136000	LOWER RINSE HEAD ASSEMBLY
13	0200000	LOWER WASH HEAD ASSEMBLY
14		WASH TANK
15		DRAIN OUTLET
16	0083300	ADJUSTABLE FOOT

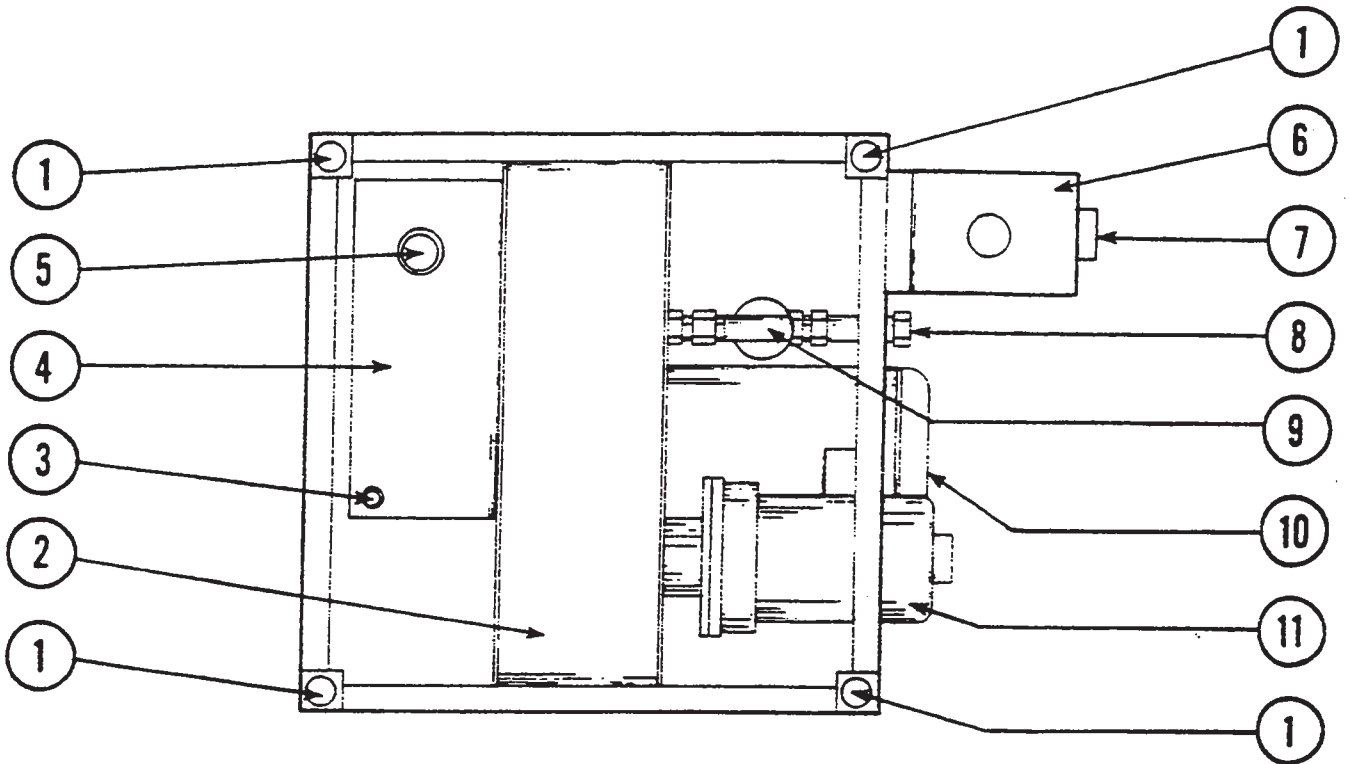

**BOTTOM VIEW .**  
**150PRB**

ITEM	P/N	DESCRIPTION
1	0083300	ADJUSTABLE FOOT
2	0006901	BOOSTER TANK
3		DETERGENT SENSOR FITTING
4		WASH TANK
5		DRAIN OUTLET
6	0030700	POWER BOX

ITEM	P/N	DESCRIPTION
7	0012000	CONTROL CIRCUIT PROTECTON DEVICE
8	0153700	"Y" STRAINER
9	0143000	SOLENOID VALVE
10	0102000	WASH PUMP & MOTOR
11	0085000	RINSE PUMP & MOTOR

**HIGH LEVEL PROBE  
P/N 0084300**

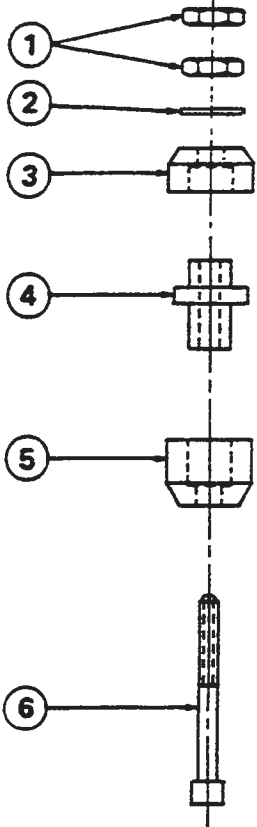

- 1 NUT, 6/32 S/S
- 2 WASHER RUBBER
- 3 PORCELAIN, OUTER
- 4 INSERT, SILASTIC
- 5 PORCELAIN, INNER
- 6 STEM

**LOW LEVEL PROBE  
P/N 0084500**

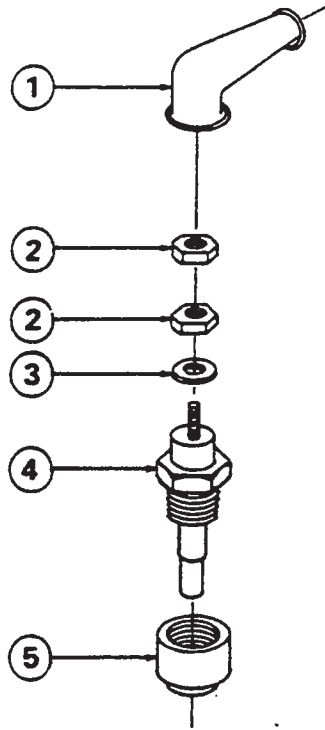

- 1 PROBE BOOT
- 2 NUTS
- 3 LOCKWASHER
- 4 PROBE
- 5 TANK COUPLING

**VACUUM BREAKER P/N 0184301**

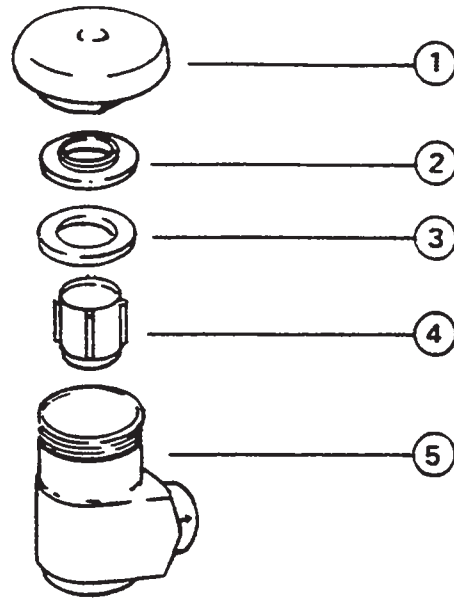

- | ITEM | P/N     | DESCRIPTION |
|------|---------|-------------|
| 1    |         | BONNET      |
| 2    | 0184700 | DISK        |
| 3    | 0184700 | GASKET      |
| 4    | 0184700 | POPPET      |
| 5    |         | BODY        |

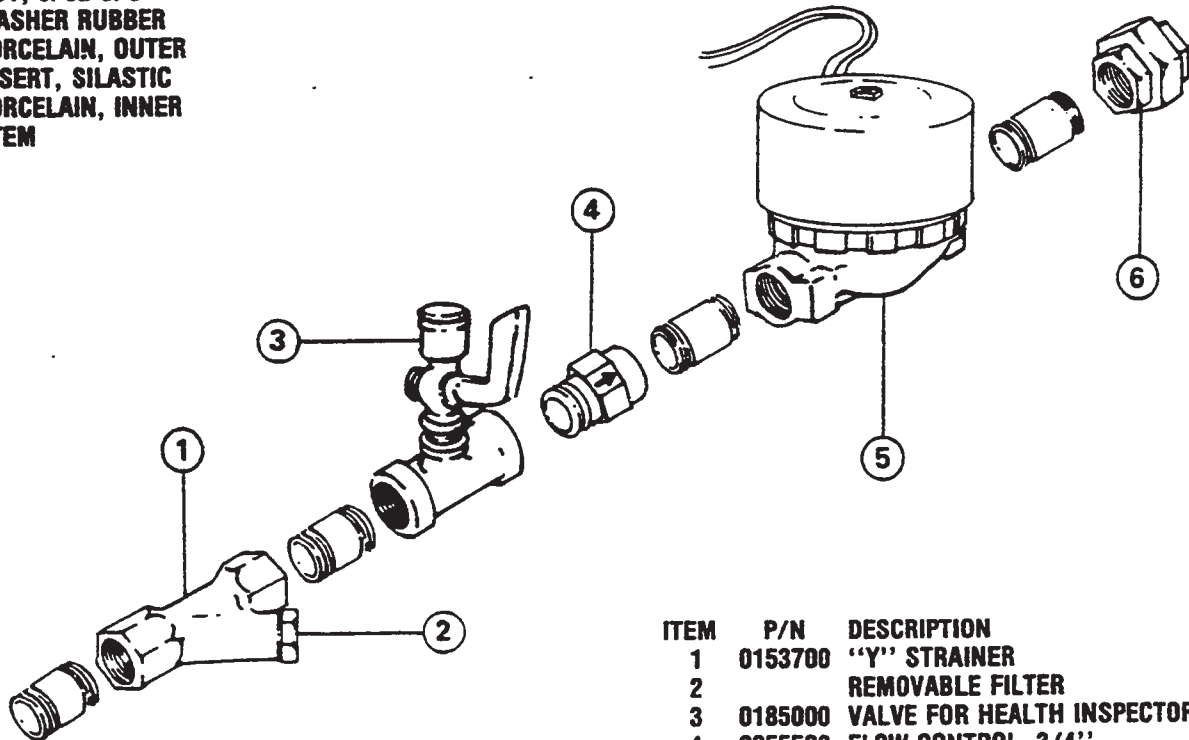

- | ITEM | P/N     | DESCRIPTION                |
|------|---------|----------------------------|
| 1    | 0153700 | "Y" STRAINER               |
| 2    |         | REMOVABLE FILTER           |
| 3    | 0185000 | VALVE FOR HEALTH INSPECTOR |
| 4    | 0055500 | FLOW CONTROL, 3/4"         |
| 5    | 0143000 | SOLENOID VALVE 3/4"        |
| 6    |         | PIPE UNION                 |

**CUTAWAY VIEW OF WASH SUMP**

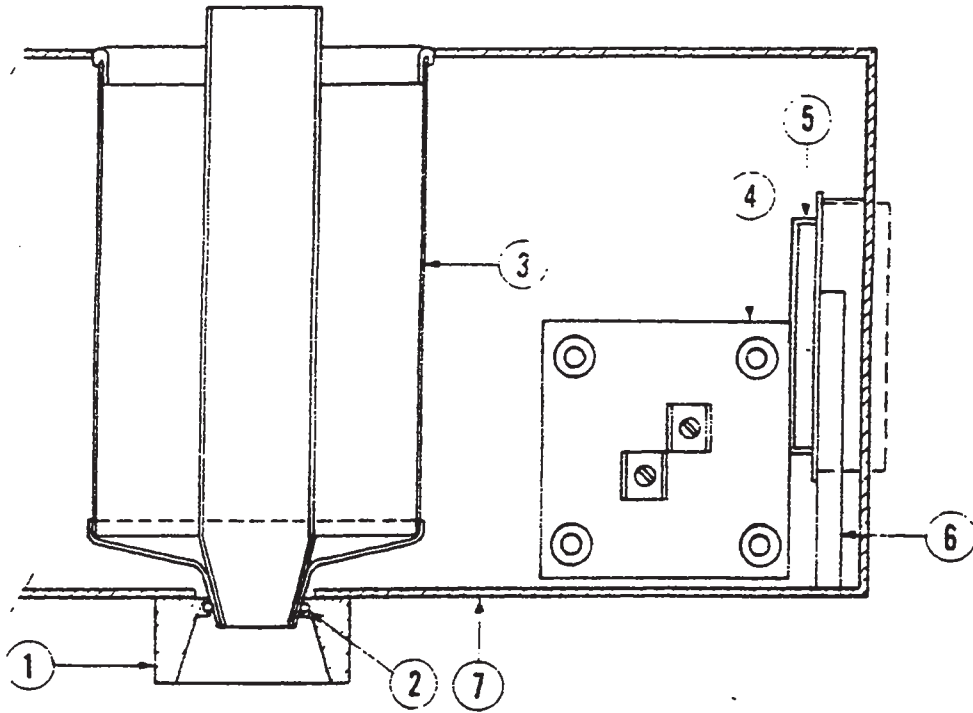

ITEM	P/N	DESCRIPTION
1		DRAIN FITTING
2	0054000	DRAIN "O" RING
3	0152000	OVERFLOW STRAINER
4	0058000	WASH TANK HEATER ELEMENT
5	0151000	INSIDE PUMP STRAINER
6		WASH TANK THERMOSTAT SHEATH
7		SUMP WALL

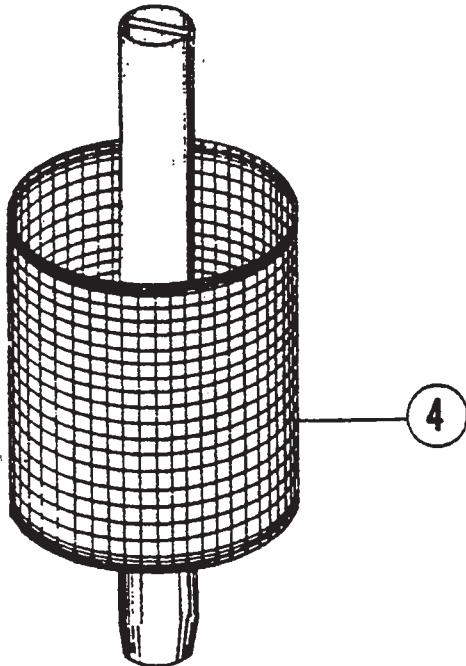

ITEM	P/N	DESCRIPTION
1		DRAIN FITTING WELDED TO WASH SUMP BOTTOM
2	0054000	DRAIN "O" RING
3	0151000	INSIDE PUMP STRAINER
4	0152000	LARGE OVERFLOW STRAINER

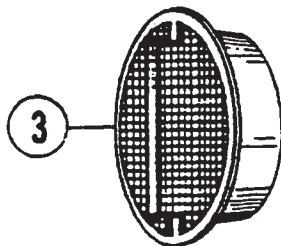
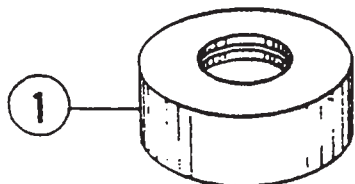

ITEM	P/N	DESCRIPTION
1	0006801	BOOSTER TANK (B MODEL)
2		EXTERNAL VACUUM BREAKER FITTING
3		THERMOSTAT PROBE, FITTING LOCATED ON SIDE
4	0058602	HEATER BUS BARS (1 PHASE CONNECTION)
5	0058600	HEATER ELEMENTS (2 EACH)
6	0058601	HEATER GASKETS (2 EACH)

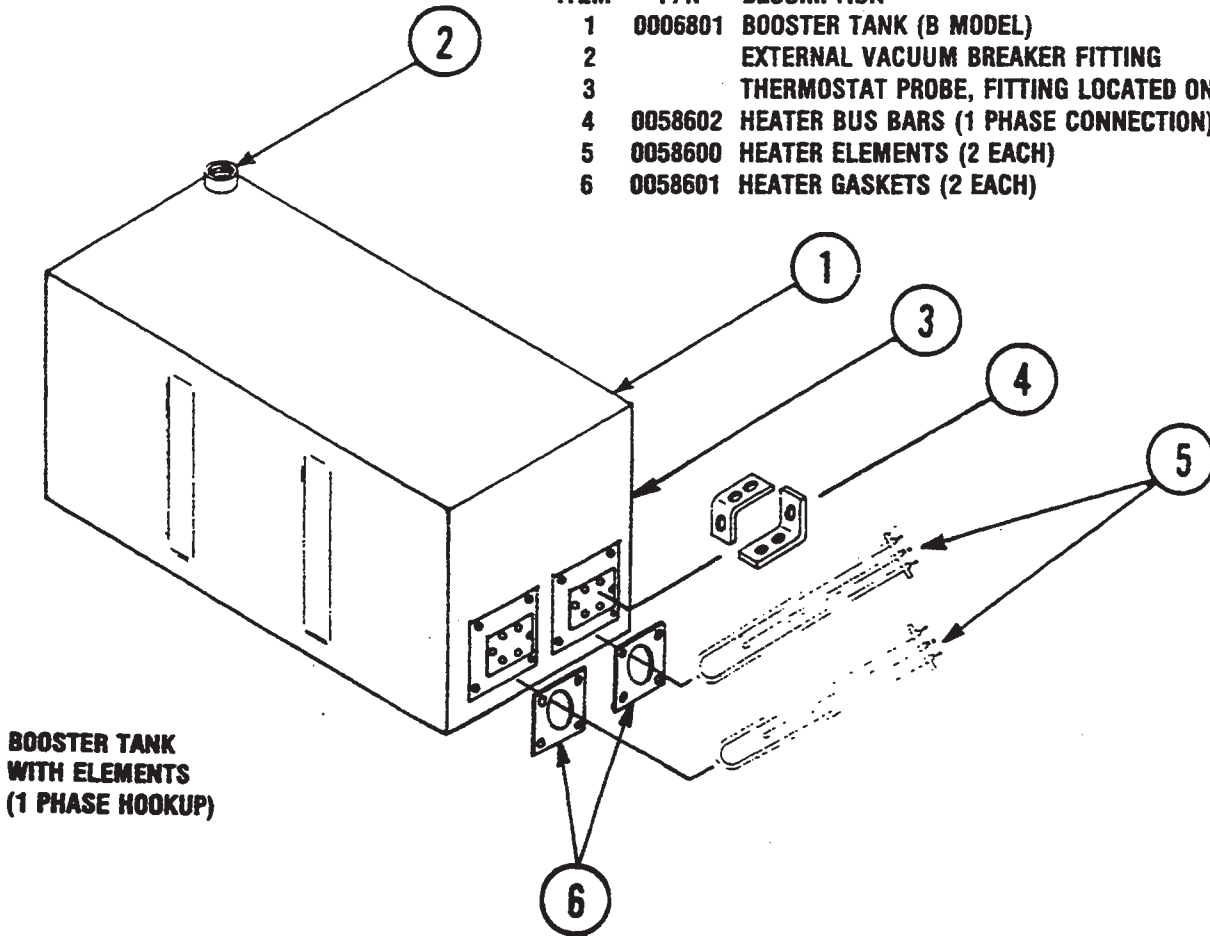

**END VIEW BOOSTER TANK (3 PHASE HOOKUP)**

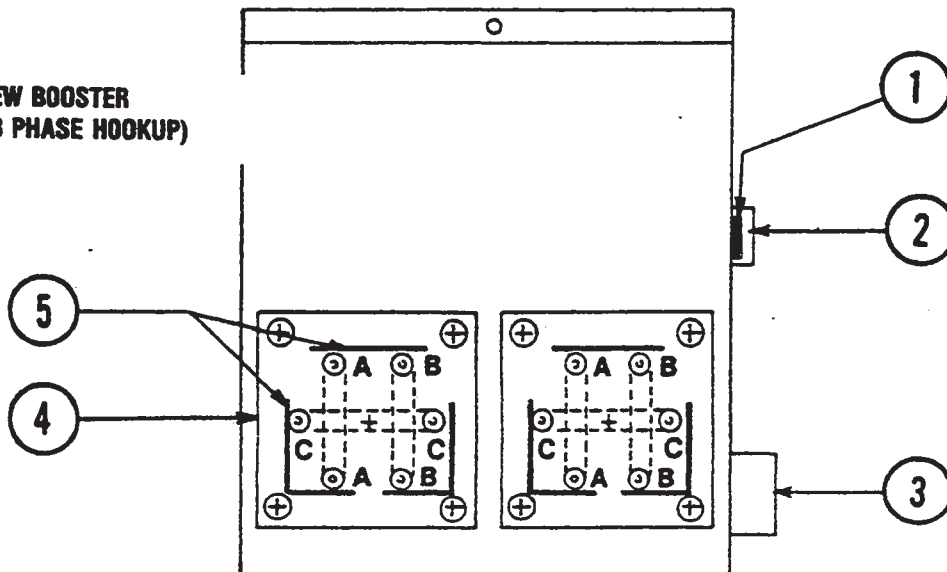

ITEM	P/N	DESCRIPTION
1		THERMOSTAT PROBE FITTING
2		THERMOMETER PROBE FITTING
3		INCOMING WATER FITTING
4	0058600	BOOSTER HEATER ELEMENTS
5	0058603	HEATER ELEMENT BUS BARS (3 PHASE CONNECTION)

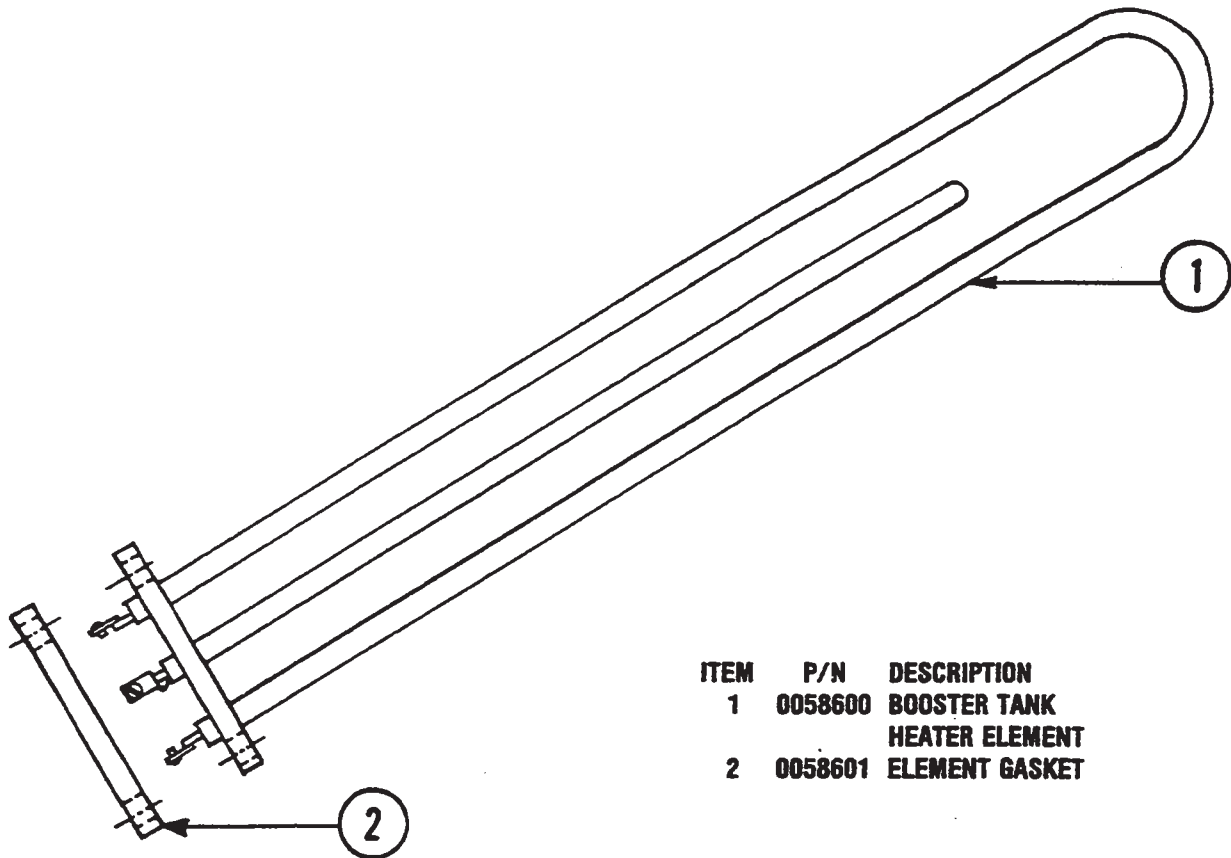

ITEM	P/N	DESCRIPTION
1	0058600	BOOSTER TANK HEATER ELEMENT
2	0058601	ELEMENT GASKET

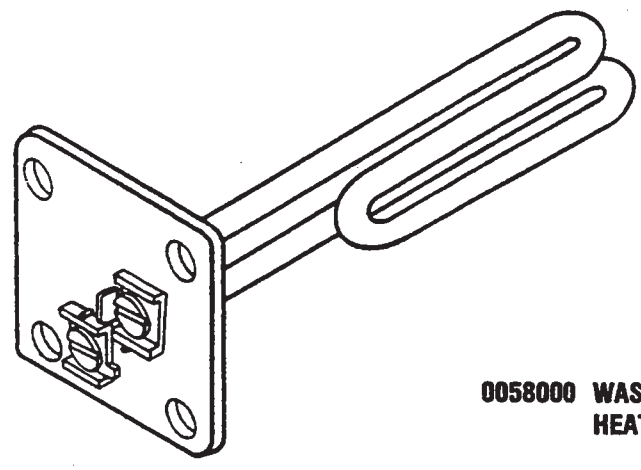

**0058000 WASH TANK  
HEATER ELEMENT**

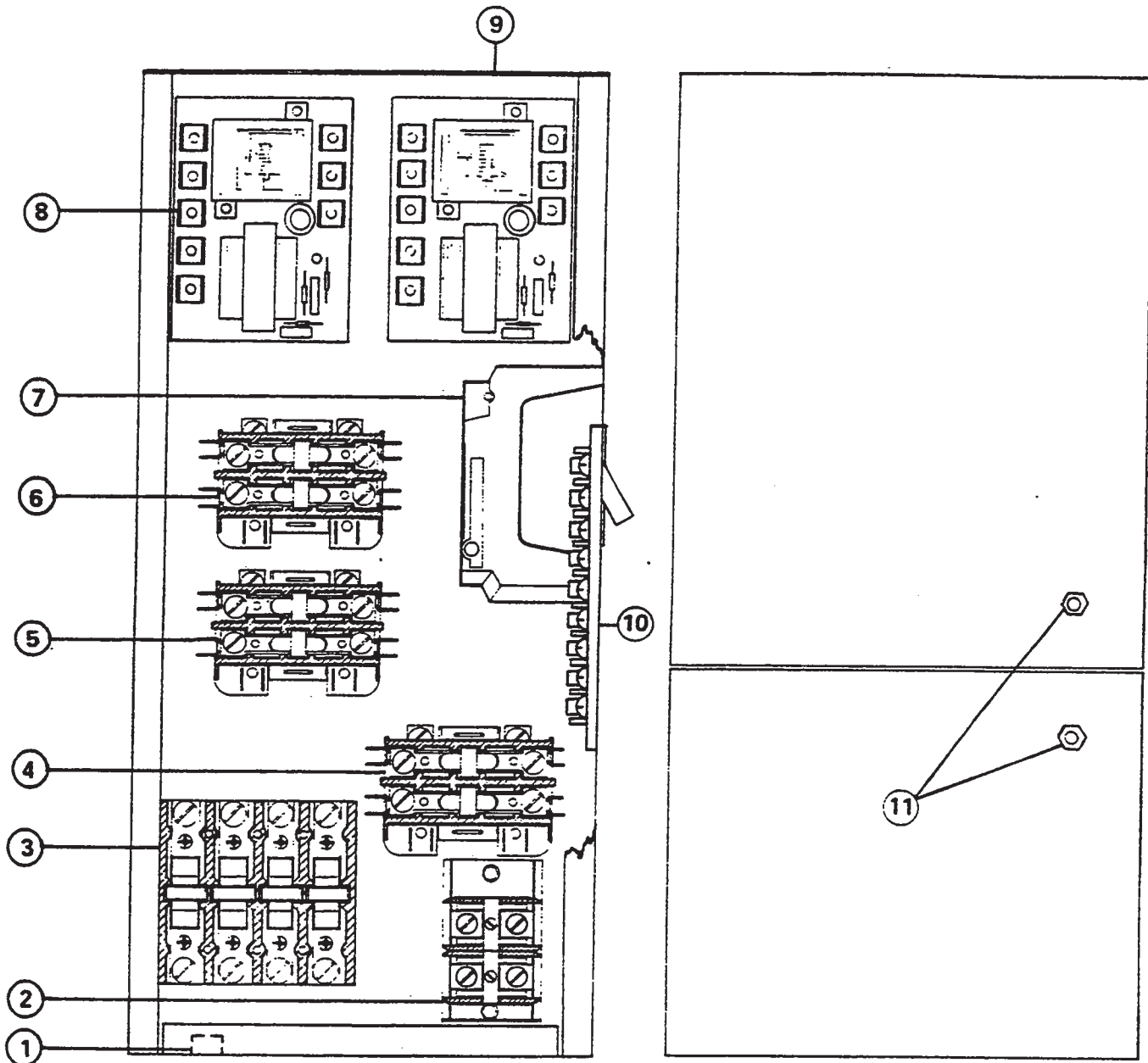

### POWER BOX AND COMPONENTS

ITEM	P/N	DESCRIPTION
1		GROUNDING LUG
2	0165500	CUSTOMER'S ELECTRIC CONNECTION
3	0123000	HEATER RELAY (3 POLE/3 PHASE)
	0124000	(4 POLE/1 PHASE)
4	0121000	RINSE/FILL RELAY
5	0121000	WASH MOTOR RELAY
6	0122000	WASH WATER RELAY
7	0012000	CONTROL CIRCUIT PROTECTION DEVICE
8	0205000	RINSE TANK WATER LEVEL CONTROL (PRB ONLY)
9	0205000	WASH HEATER WATER LEVEL CONTROL
10	0167000	TERMINAL BOARD
11		GROUNDING STUD



#1. CUSTOMER FURNISHED

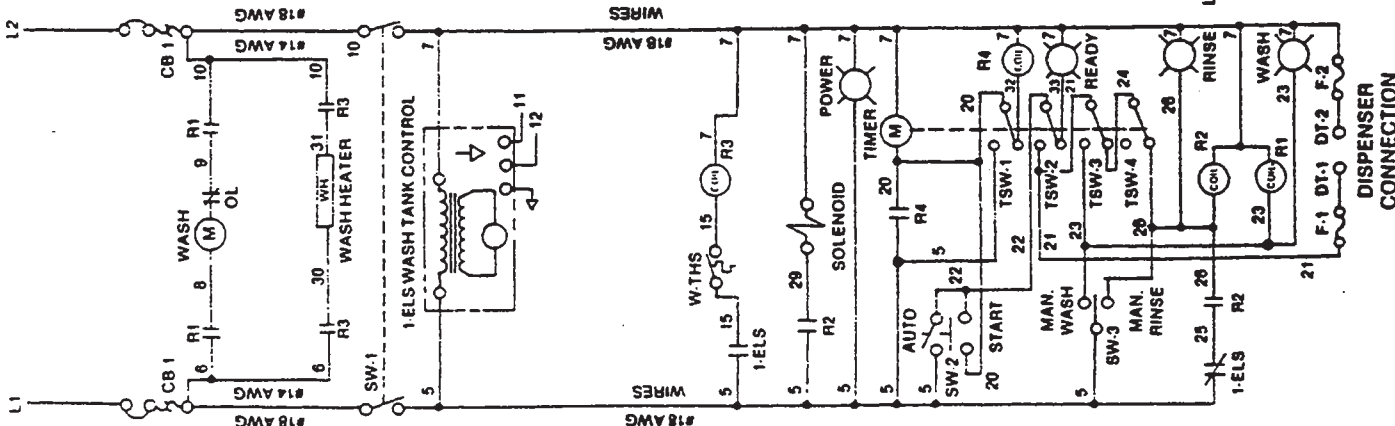

CONTROL UNIT

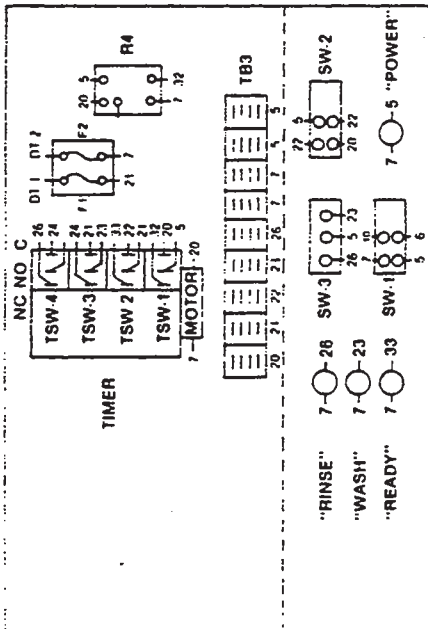

- WH: Wash Heaters (1) 1500W
- CB 1: Overcurrent, current circuit breaker, 15 amp rating
- R-1: Wash Motor Contactor
- R-2: Rinse Cycle Contactor
- R-3: Wash Heat Contactor
- R-4: Timer Holding Relay
- SW-1: Power Switch, On-Off
- SW-2: Cycle Switch selects manual, auto, & start functions
- SW-3: Manual Switch, selects manual wash or fill & manual runs
- TSW-1: Timer Switch, runs timer 1-complete cycle
- TSW-2: Timer Switch, controls power to TSW-3, TSW-4, Relay & Accessory Dispenser Connection
- TSW-3: Timer Switch, controls wash cycle
- TSW-4: Timer Switch, controls rinse cycle
- 1 ELS: Control, High Level Fill, Low Level cut off in wash tank heat, Low Voltage Sensor, 24V Probe
- W-THS: Independent T'stat control, wash tank heat
- DT 1&2: Dispenser Connection
- WM: Wash Motor

POWER UNIT

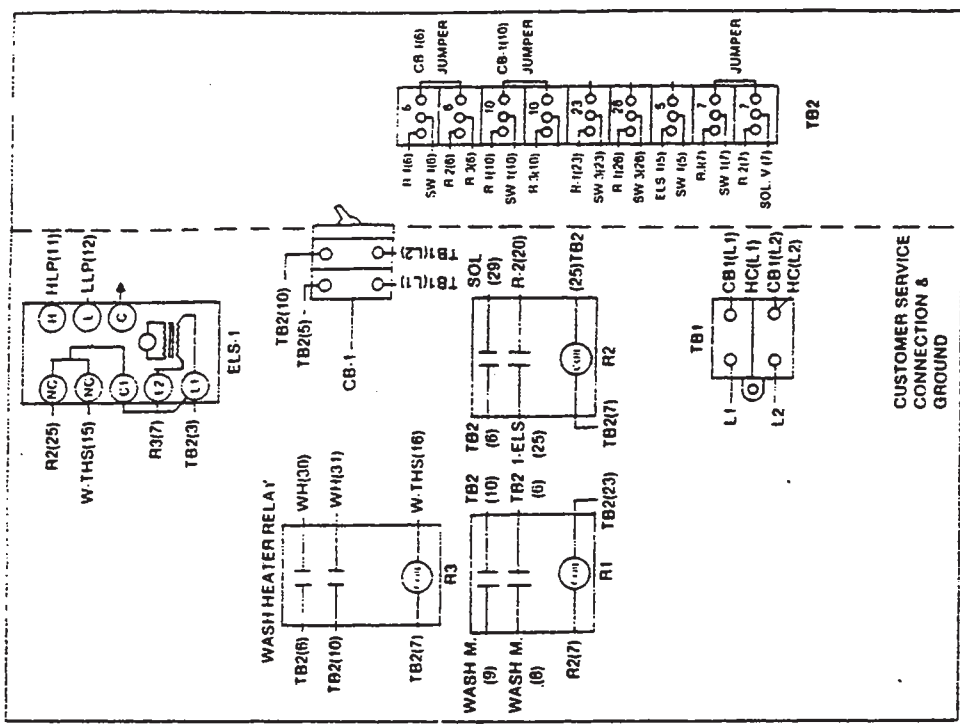

CUSTOMER SERVICE CONNECTION & GROUND

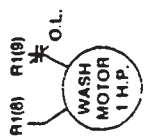

SCHEMATIC & WIRING DIAGRAM  
150  
208-220V  
60 CY 1 PH

#4 AWG CUSTOMER FURNISHED

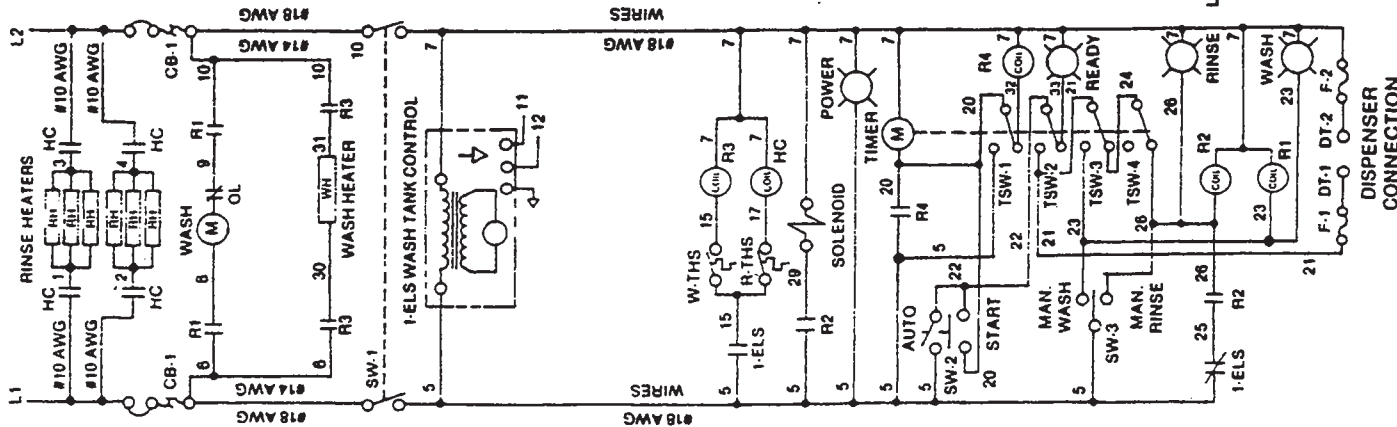

CONTROL UNIT

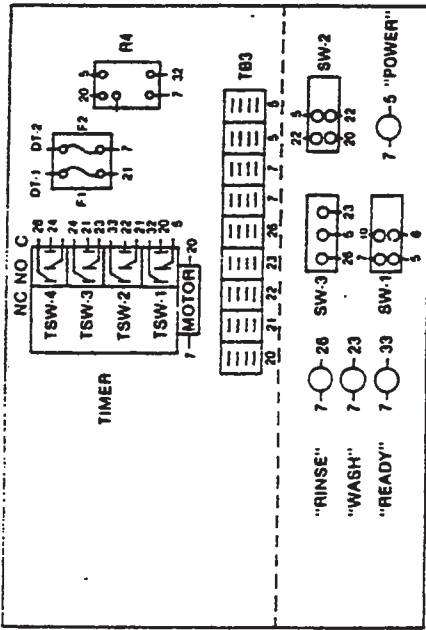

- HC: Contactor (Heater, Rinse)
- RH: Rinse Heaters (2) 6700W
- WH: Wash Heaters (1) 1500W
- CB-1: Overcurrent, current circuit breaker, 15 amp rating
- R-1: Wash Motor Contactor
- R-2: Rinse Cycle Contactor
- R-3: Wash Heat Contactor
- R-4: Timer Holding Relay
- SW-1: Power Switch, On-Off
- SW-2: Cycle Switch, selects manual, auto, & start functions
- SW-3: Manual Switch, selects manual wash or fill & manual runs
- TSW-1: Timer Switch, runs timer 1-complete cycle
- TSW-2: Timer Switch, controls power to TSW-3, TSW-4, Relay & Accessory Dispenser Connection
- TSW-3: Timer Switch, controls wash cycle
- TSW-4: Timer Switch, controls rinse cycle
- 1-ELS: Control, High Level Fill, Low Level cut-off in wash & runs tank heat, Low Voltage Sensor 24V Probe
- W-THS & R-THS: Independent T-stat control, wash & runs tank heat
- DT-1&2: Dispenser Connection
- WM: Wash Motor

POWER UNIT

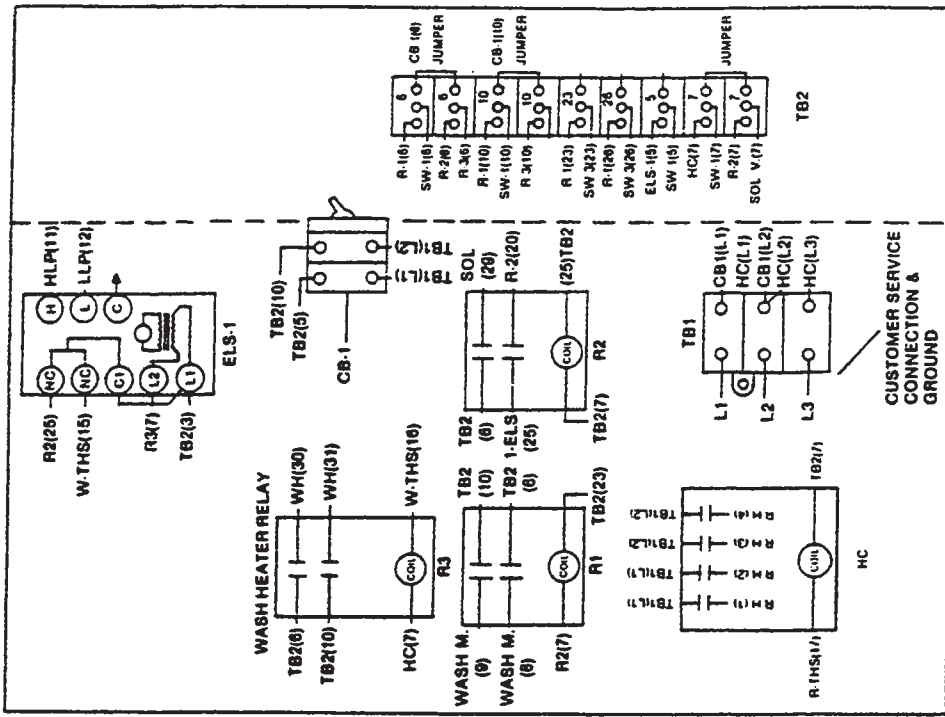

SCHEMATIC & WIRING DIAGRAM  
150B  
208-220V  
60 CY 1 PH

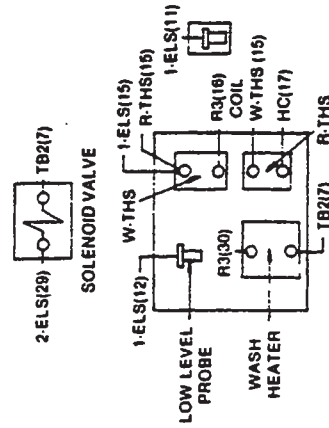
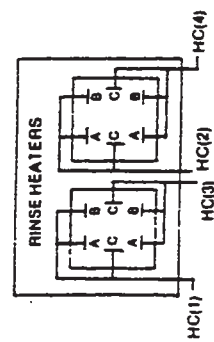
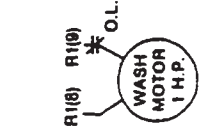

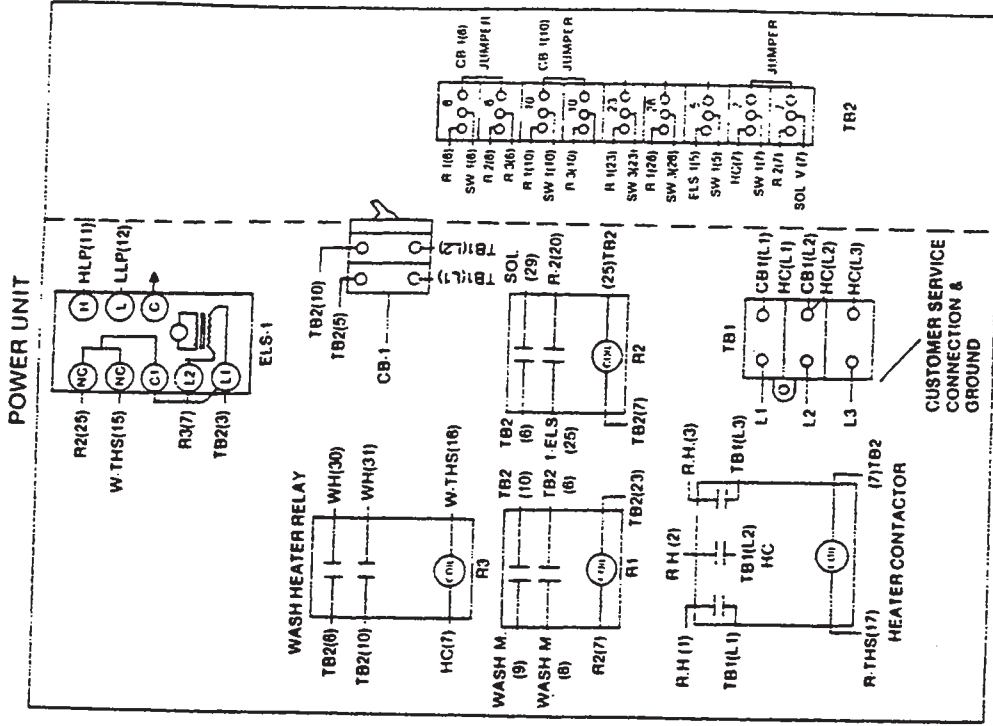
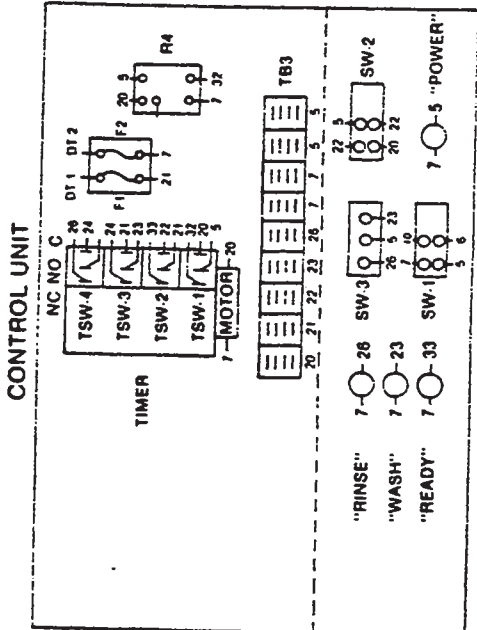
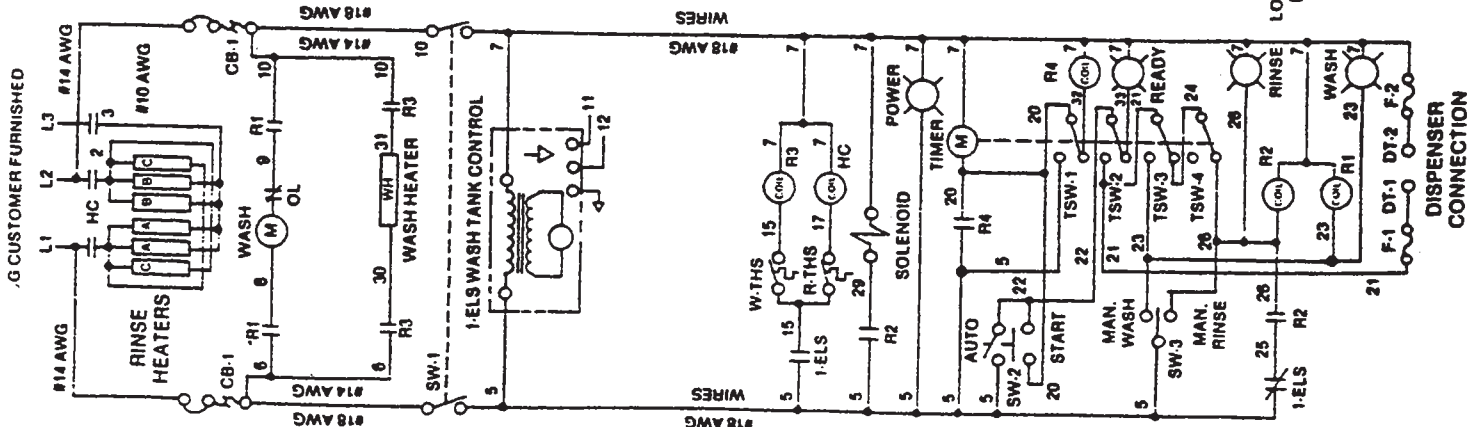

- HC: Contactor (Heater, Rinse)
- RH: Rinse Heaters (2) 6700W
- WH: Wash Heaters (1) 1500W
- CB-1: Overcurrent, current circuit breaker, 15 amp rating
- R-1: Wash Motor Contactor
- R-2: Rinse Cycle Contactor
- R-3: Wash Heat Contactor
- R-4: Timer Holding Relay
- SW-1: Power Switch, On-Off
- SW-2: Cycle Switch selects manual, auto, & start functions
- SW-3: Manual Switch, selects manual wash or fill & manual runs
- TSW-1: Timer Switch, runs timer 1-complete cycle
- TSW-2: Timer Switch, controls power to TSW-3, TSW-4, Relay & Accessory Dispenser Connection
- TSW-3: Timer Switch, controls wash cycle
- TSW-4: Timer Switch, controls rinse cycle
- 1-ELS: Control, High Level Fill, Low Level cut off in wash & runs tank heat.
- W-T.H.S. & R-T.H.S. Independent float control, wash & runs tanks heat
- DT-1&2: Dispenser Connection
- WM: Wash Motor

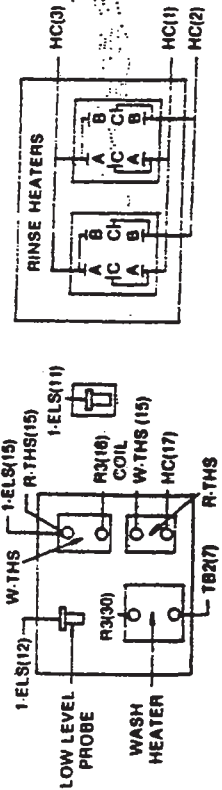

SCHEMATIC & WIRING DIAGRAM  
150B  
208-220V  
60 CY 3 PH

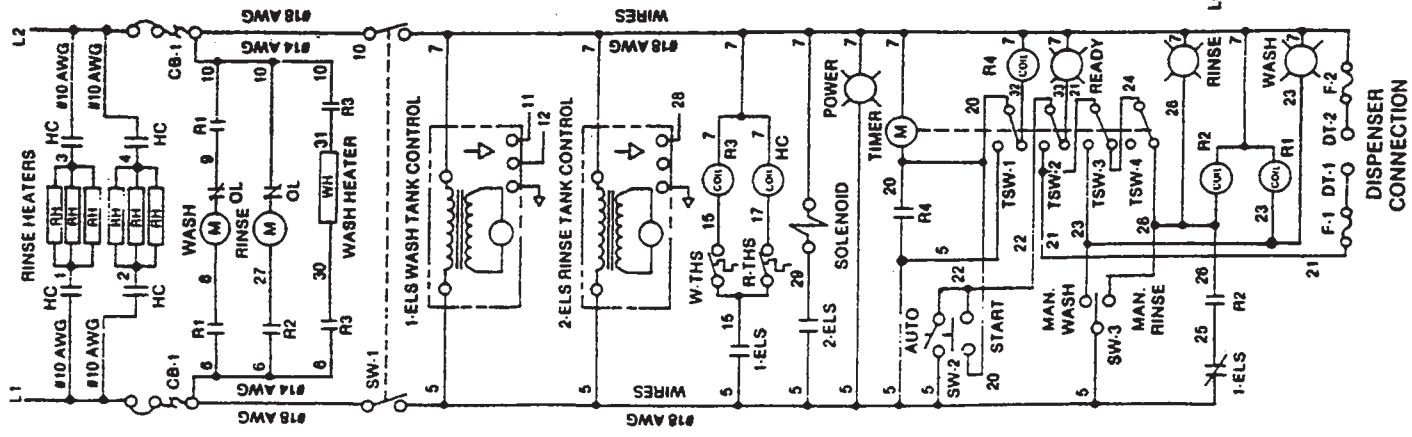

**CONTROL UNIT**

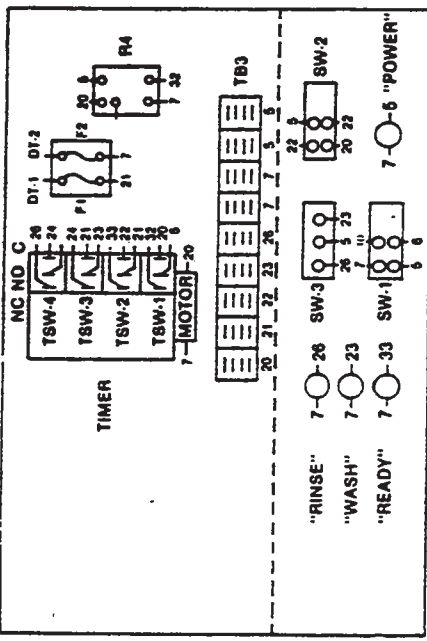

- HC: Contactor (Heater, Rinse)
- RH: Rinse Heaters (2) 8700W
- WH: Wash Heaters (1) 1500W
- CB-1: Overcurrent, current circuit breaker, 15 amp rating
- R-1: Wash Motor Contactor
- R-2: Rinse Cycle Contactor
- R-3: Wash Heat Contactor
- R-4: Timer Holding Relay
- SW-1: Power Switch, On-Off
- SW-2: Cycle Switch selects manual, auto, & start functions
- SW-3: Manual Switch, selects manual wash or fill & manual runs
- SW-4: Timer Switch, runs timer 1-complete cycle
- TSW-1: Timer Switch, controls power to TSW-3, TSW-4, Relay & Accessory Dispenser Connection
- TSW-2: Timer Switch, controls wash cycle
- TSW-3: Timer Switch, controls rinse cycle
- TSW-4: Timer Switch, independent rinse cycle
- 1-ELS: Control, High Level Fill, Low Level cut-off in wash & runs tank heat, Low Voltage Sensor 24V Probe
- 2-ELS: Control, Rinse Tank Water Level, Low Voltage Sensor 24V Probe
- W-THS & R-THS: Independent T'sial control, wash & runs tanks heat
- DT 1&2: Dispenser Connection
- RM: Rinse Motor
- WM: Wash Motor

**POWER UNIT**

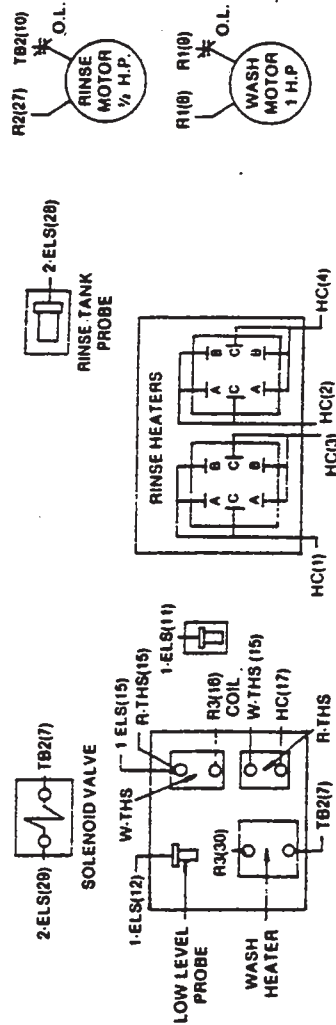
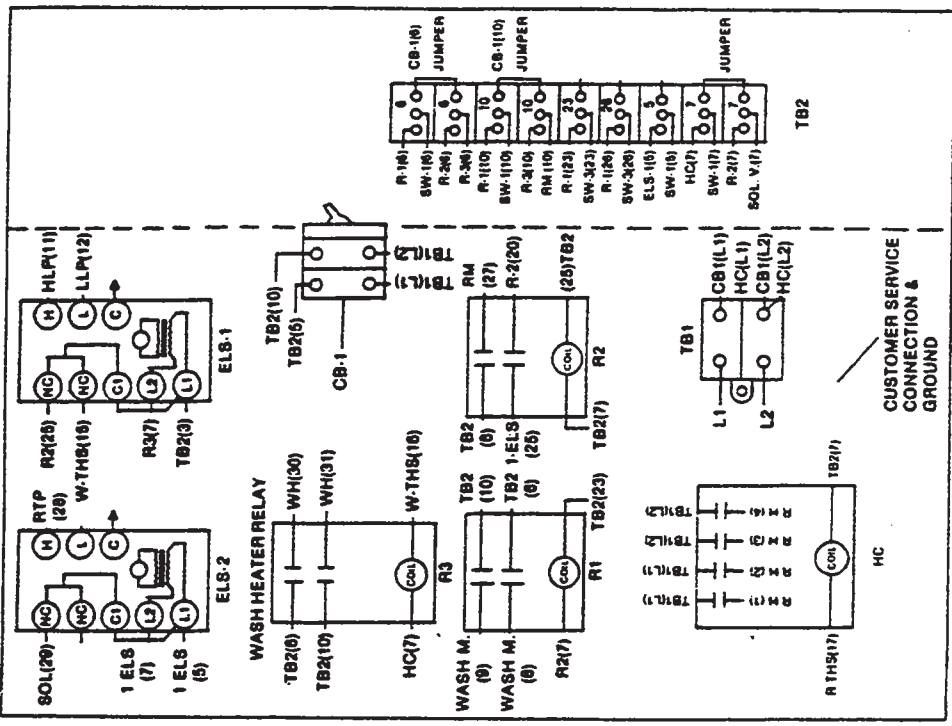

SCHEMATIC & WIRING DIAGRAM  
150PRB  
208-220V  
60 CY 1 PH

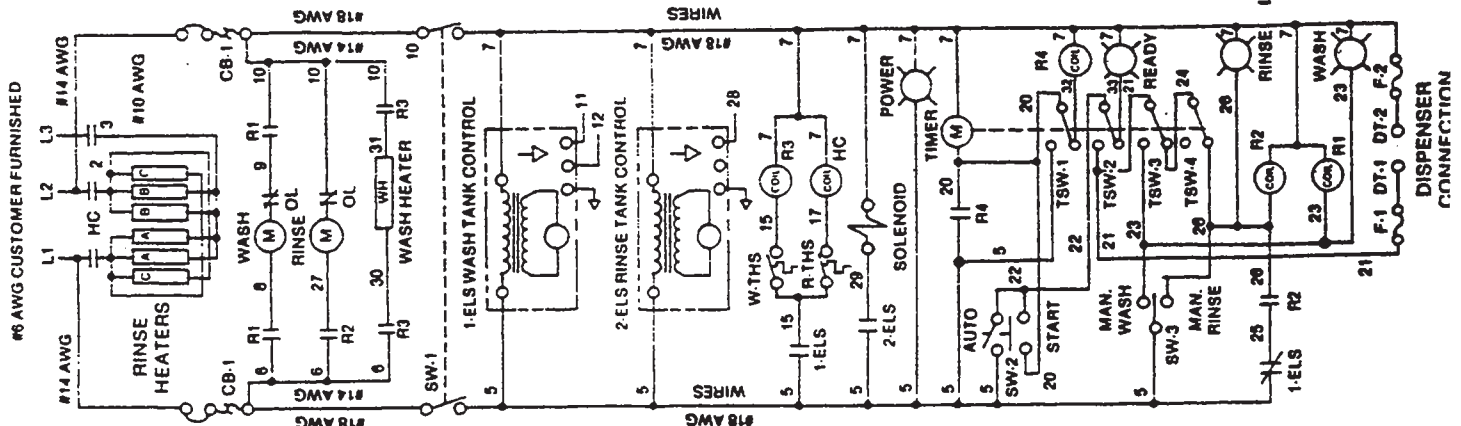

**CONTROL UNIT**

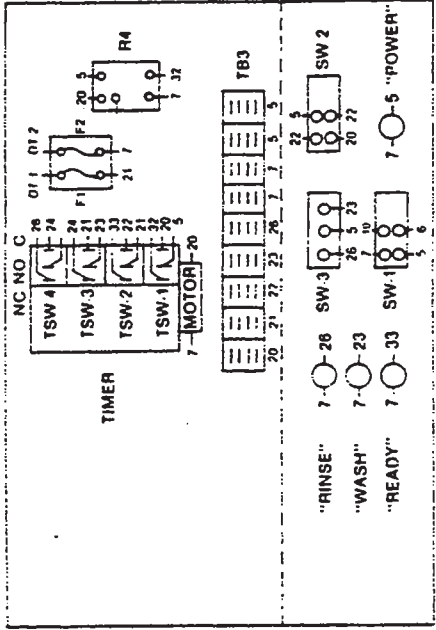

**POWER UNIT**

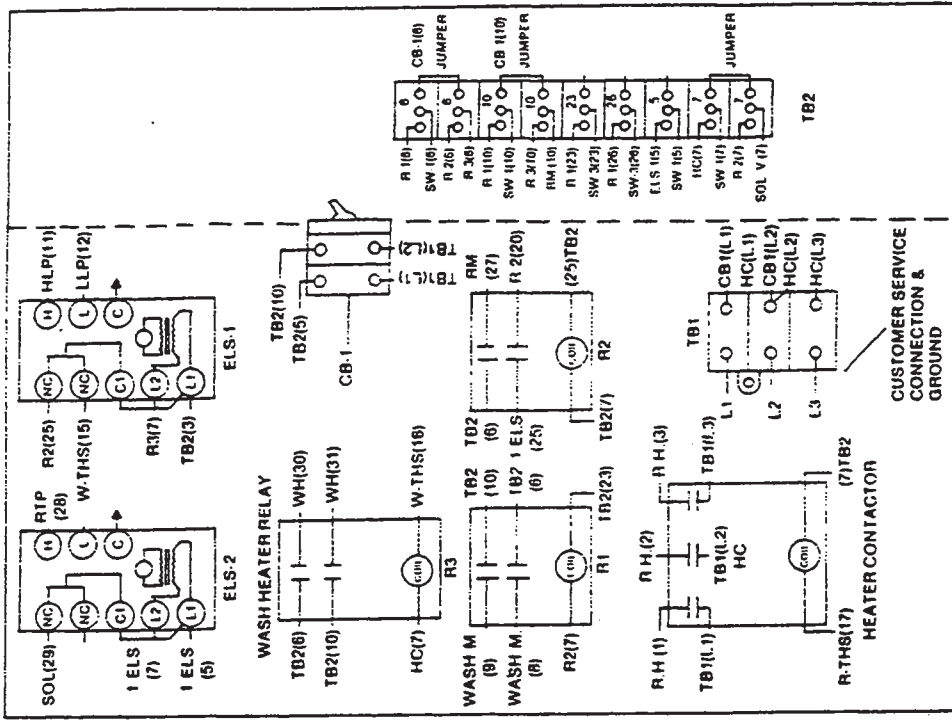

- HC: Contactor (Heater, Rinse)
- RH: Rinse Heaters (2) 6700W
- WH: Wash Heaters (1) 1500W
- CB-1: Overcurrent, current circuit breaker, 15 amp rating
- R-1: Wash Motor Contactor
- R-2: Rinse Cycle Contactor
- R-3: Wash Heat Contactor
- R-4: Timer Holding Relay
- SW-1: Power Switch, On Off
- SW-2: Cycle Switch selects manual, auto, & start functions
- SW-3: Manual Switch, selects manual wash or fill & manual runs
- TSW-1: Timer Switch, runs timer 1-complete cycle
- TSW-2: Timer Switch, controls power to TSW-3, TSW-4, relay & Accessory Dispenser Connection
- TSW-3: Timer Switch, controls wash cycle
- TSW-4: Timer Switch, controls rinse cycle
- 1-ELS: Control, High Level Fill, Low Level cut off in wash & runs tank heat, Low Voltage Sensor 24V Probe
- 2-ELS: Control, Runs Tank Water Level, Low Voltage Sensor 24V Probe
- W.THS & R.THS: Independent float control, wash & runs tanks heat
- DT-1&2: Dispenser Connection
- RM: Rinse Motor
- WM: Wash Motor

SCHEMATIC &  
WIRING DIAGRAM  
150PRB  
208-220V  
60 CY 3 PH

# PARTS LIST FOR MODEL 150 B/PRB DISHWASHERS

PART NUMBER	DESCRIPTION	SERIAL NUMBERS	150
0006801	Booster tank for machine (stripped) B	All	1
0006900	Booster tank for machine (stripped) PRB	All	1
0008900	Cantilever Assy. Comp. (incls. parts 0008901, 0008902, 0008700, 0009000, 0009400, 0009600, 0010000, 0010300, 0010600, 0010900, 0011200)	All	1
89A	Cantilever Arm, ONLY 1" dia. (use 0008901)	All	1
89B	Cantilever Handle Grips (use 0008902)	All	1
0008700	Cantilever Spring Rods	All	1
0008800	Cantilever, removable tabs, w/nuts	All	2
90A	Cantilever Springs Corner & Straight thru (use 0009001)	All	2
0009400	Cantilever Eye Bolts	All	2
0009600	Cantilever nuts, for eye bolts	All	4
0010000	Cantilever sleeve	All	2
0010300	Cantilever bolt, for sleeve 1/4" x 1 3/8"	All	2
0010600	Cantilever washer flat, for sleeve bolt 1/4"	All	4
0010900	Cantilever acorn nut, for sleeve bolt 1/4"	All	2
0011200	Cantilever lockwasher, for sleeve bolt 1/4"	All	2
0011500	Cantilever coupler door, to cantilever	All	2
0012000	Circuit Breaker, 15 amp (specify number from Part)		1
0020400	Control Box Complete wired, Upper, B/PRB		1
0021800	Control Box (stripped) ONLY, Upper		1
0030600	Control Power Box, Lower, B		1
0030700	Control Power Box, Lower, PRB		1
0027400	Control Panel only wired, Upper, B/PRB	All	1
0047000	Door, front, standard model (use 0047500)	All	1
0047500	Door, front, and sides	All	1
0048000	Door, side (use 0047500)	All	2
0048500	Door catch, front	All	1
0049000	Door spacer, side	All	2
0049500	Door screw, for spacer 1/4" x 1 3/8"	All	2
0010600	Door washer flat, 1/4", s/s	All	2
0010900	Door acorn nut, for spacer 1/4", s/s	All	2
0050900	Door knob (front w/screw)	All	1
0051800	Door strips or guides	All	6
0053100	Door ONLY (false panel for corner model)	All	1
0054000	Drain 'O' ring		1
0055500	Flow Control, 11.5 gpm, 3/4"		1
0056000	Gauge, pressure, 0-60, bottom connection	All	1
0058000	Heater element, Immersion, flange type, w/gasket, 220V, 1500W	All	1
0058500	Heater gasket, immersion element flange type, above	All	1w
586A	Heater element, flange type, gasket (use 0058601)		2
586B	Heater bus bars, single phase, set (use 0058602)	All	2
586C	Heater bus bars, three phase, set (use 0058603)	All	2
0058600	Heater element, Immersion, flange type, 208/230V, 6700W	All	2
835A	Light indicator, Amber (use 0083501)	All	2
835G	Light indicator, Green (use 0083507)		1
835R	Light indicator, Red (use 0083518)		1
0084300	Probe; small Lundy		2w
0084500	Probe; large Warrick Hi-level	All	1R
0084700	Probe; cover rubber (for 845)	All	1R

# PARTS LIST FOR MODEL 150 B/PRB DISHWASHERS

PART NUMBER	DESCRIPTION	SERIAL NUMBERS	150
0085000	Pump assy. comp. w/motor, 1/2 HP, 3450 RPM, Rinse (PRB Only)		1R
0086000	Pump, motor 115/230V 1/2 HP, 3450 RPM, JET, Rinse (PRB Only)	All	1R
0087500	Pump seal (for pump parts 850-863-920-925)	All	1R
0088000	Pump mounting plate (for pump parts 850-863)		1R
0089000	Pump ceramic face w/retainer cup (for pump parts 850-863-920-925)	All	1R
0089500	Pump impeller 2 3/4" dia. 7/16" tap (for pump 850-863)		1R
0090000	Pump gasket (for pump parts 850-863) (mounting)	All	1R
0090500	Pump bolts (for pump parts 850-863)	All	1R
0091000	Pump lockwashers (for pump Parts 850-863-920-925)	All	4X
0091500	Pump nuts (for pump parts 863-862-920-925)	All	4X
0102000	PUMP ASSEMBLY, COMPLETE, JET 1 HP 1725 RPM	All	1W
0102700	Pump motor, JET, 100/208V-230V, 1 HP 1725 RPM	All	1W
0104500	Pump mounting plate (for part 1020)	All	1W
0105000	Pump seal and ceramic (for part 1020)	All	1W
0105500	Pump impeller (for part 1020)	All	1W
0106000	Pump gasket, square (for part 1020) (mounting)	All	1W
0106500	Pump, Woodruff Key (for part 1020)	All	1W
0107000	Pump bolt, Impeller, s/s 5/16"-18 x 1" (for part 1020)	All	1W
0107500	Pump washer, Impeller (for part 1020)	All	1W
0108000	Pump snap ring (for part 1020)	All	1W
00	Pump bolts, 3/18-16 x 1 1/4" Cap HH (for part 1020)	All	4W
00	Pump lockwashers (for part 1020)	All	8W
0117500	Rack, SQUARE, 19 3/4" x 19 3/4" (cup, bowl & glass) moulded		1
0117800	Rack, SQUARE, 19 3/4" x 19 3/4" (dish) moulded		1
0121000	Relay, 220V, 2-pole, HW (used on rinse & wash circuit)		1
0122000	Relay 220V, 2-pole wash heater		
0123000	Relay, 220V, 3-pole, HW (used on heat circuit, three phase)	All	1
0123300	Relay, Timer holding (SPDT) 220V		1
0124000	Relay, 220V, 4-pole, HW (used on heat circuit, single phase)	All	1
0127000	Rinse Head, End plug (nylon)	All	4
0132500	Rinse head hex bushing, s/s	All	2
0133000	Rinse head nylatron washer	All	2
0133500	Rinse head snap rings, s/s	All	2
0134000	Brush, tube cleaning, large	All	1
0136000	Rinse head upper & lower interchange	All	2
0136500	Rinse head feed pipe, Upper	All	1
0137000	Rinse head feed pipe, Lower	All	1
0143000	Solenoid valve, 3/4", 220V, JE	All	1
0143100	Solenoid valve, 3/4", 220V, JE, GP (use 0143000)		1
0144000	Solenoid valve coil, 220V, JE (for 1/2" & 3/4")		1
0145500	Solenoid valve diaphragm cartridge, and 'O' ring, 3/4", JE	All	1
0145600	Solenoid valve diaphragm cartridge, 3/4" JE, GP		1
0148000	Solenoid valve 'O' ring, 3/4", JE	All	1
0148500	Solenoid valve, plunger assembly, for 1/2" and 3/4", JE		1
0148600	Solenoid valve plunger assembly, 1/2" & 3/4", JE, GP		1
0150000	Solenoid valve strainer screen, 3/4" JE	All	1
0	Solenoid valve gasket, 3/4" JE, GP		1
0151000	Strainer, small pump intake	All	1
0152000	Strainer, large overflow	All	1
0153700	Strainer, 'Y', 3/4"	All	1
0155600	Switch, manual wash/rinse-fill, rocker type		1
0158900	Switch, automatic, start, manual mode, rocker type		1

# PARTS LIST FOR MODEL 150 B/PRB DISHWASHERS

PART NUMBER	DESCRIPTION	SERIAL NUMBERS	150
0162000	Switch, power, on/off, rocker type .....		1
0165500	Terminal Board, 3-pole, complete .....	All	1
0167000	Terminal Board, 9-pole, complete slip terminal .....		1
0169200	Thermometer, wash or rinse, 6 ft. cap .....	All	2
1700R	Thermostat, rinse, 180-195° (use 0170018) .....	All	1
1700W	Thermostat, wash, 150-160° (use 0170023) .....		1
0173900	Timer, 220V, 60 sec., 4 cam .....		1
1739A	Timer motor, 220V (use 0173901) .....		1
0177500	Timer micro switches, plastic module type .....	All	3
0179000	Track, standard, front or back (use 0180000) .....	All	1
0180000	Track, corner model, convertable .....	All	1
0184300	Vacuum breaker, 3/4" Sloan (use 0184301) .....		1
0184700	Vacuum Breaker Kit (float & seal) 3/4" Sloan .....		1
0185000	Valve, 1/4" (for Health Inspector's gauge) .....	All	1
0186500	Wash head cap w/race .....		1
0187000	Wash head cap set screw .....		2
0187500	Wash head center shaft .....		2
0188500	Wash head holding bolt .....		2
0044700	Wash head nut for holding bolt (nylon insert) .....		2
0193500	Wash head fixed race .....		2
0194004	Wash head bearings, 1/4", s/s .....	All	114
0194500	Wash head spray tube ONLY, long length .....	All	(as reqd/rep)
0200000	WASH HEAD ASSY., UPPER & LOWER INTERCHANGE .....	All	2
0200500	Wash head, small manifold w/tubes .....	All	2
0201000	Wash head, large manifold w/tubes .....	All	2
0205000	Water level control, Curtis, 220V .....		1
0205500	Water level control, relay ONLY, Curtis .....		1
0206000	Water level control, printed board ONLY, Curtis .....		1
0009459	Rack support rod (vee shape) rod only		
0180001	Rack support rod assembly		
0008201	Cantilever arm support bracket		
0009100	Cantilever arm yoke assembly		
0058200	Heater element flange 208V, 1500W		
0051900	Door plugs black plastic		
0008501	Cantilever arm plugs		
0055100	Bottom front panel		
0136700	Vertical feed pipe (upper and lower rinse feed pipe)		
0163700	Front door switch (some models) 3 term.		
0163800	Side door switch (some models) 6 term.		
0048801	Spacer kit door wraparound		
0138900	Rinse feed pipe support		
0049800	Door wraparound		
6047603	Conversion kit straight thru to corner		





## Free Manuals Download Website

<http://myh66.com>

<http://usermanuals.us>

<http://www.somanuals.com>

<http://www.4manuals.cc>

<http://www.manual-lib.com>

<http://www.404manual.com>

<http://www.luxmanual.com>

<http://aubethermostatmanual.com>

Golf course search by state

<http://golfingnear.com>

Email search by domain

<http://emailbydomain.com>

Auto manuals search

<http://auto.somanuals.com>

TV manuals search

<http://tv.somanuals.com>