



# TempStar™ HH

Project \_\_\_\_\_  
 Item \_\_\_\_\_  
 Quantity \_\_\_\_\_  
 CSI Section 11400 \_\_\_\_\_  
 Approval \_\_\_\_\_  
 Date \_\_\_\_\_

## Models

- TempStar™ HH (70°F-rise Booster)     TempStar™ HH (40°F-rise Booster)     TempStar™ HH with No Booster



### Standard Features

- Sani-Sure™ feature assures proper rinse water temperature
- Multi-cycle timer (Extra Heavy, Heavy, Medium, Normal)
- Extended 15 sec. high-temperature rinse provides superior coverage and rapid drying
- 20 3/4" (527 mm) wide x 27" (686 mm) high opening accommodates 18" (457) X 26" (660 mm) sheet pans and 60-quart mixing bowls
- Auto-fill / auto-start
- Safety door switch
- Delime/manual wash switch
- Low-watt density electric wash tank heater
- Hi-limit thermostat and low-water protection
- Adjustable bullet feet
- Uses standard 20" x 20" (508 mm x 508 mm) racks
- Front dress panel
- Detergent/rinse additive signal connection fuse box
- Built-in 70°F(21°C)-rise booster heater is part of Sani-Sure™ feature and standard
- Lower counterrotating wash arms and upper wash arm provide optimum spray coverage and superior cleaning action
- Self-draining stainless steel pump
- Split-door design accommodates installations with low ceilings
- Large scrap tray

### Mandatory Specs

- Specify voltage
- Specify booster size
- Specify electric or steam

### Optional Features

- 40°F- (4.5°C- ) rise booster heater available at no additional cost if specified at time of order
- With no booster heater
- Drain quench system
- Scaltrol
- Flanged feet
- Water hammer arrestor

### Accessories

- 36" (914 mm) compartment rack 4 1/6" (4 mm) tall
- 36" (914 mm) compartment rack 5 5/8" (16 mm) tall
- 36" (914 mm) compartment rack 7" (178 mm) tall
- Combination rack
- Peg rack
- Sheet pan rack (18" x 26"/ 457 mm x 660 mm baking pans)

## Specifications

Uses 1.36 gallons (5 liters) of 180°F (82°C) water per rack

Total automatic (normal) cycle - 62 seconds

53 racks per hour normal cycle

2 HP wash pump motor

Single-point connections for all utilities

Built-in water pressure regulator and gauge

Field convertible from straight-through to corner operations

Heavy duty stainless steel construction



#### SHIPPING ADDRESS

6209 North U.S. Highway 25E  
Gray, KY 40734

#### MAILING ADDRESS

P. O. Box 1060  
Barbourville, KY 40906

Tel: 606-523-9795

Tel: 1-888-800-5672

Fax: 606-523-1799

[www.jacksonmsc.com](http://www.jacksonmsc.com)

E-mail: [customerservice@jacksonmsc.com](mailto:customerservice@jacksonmsc.com)

07610-002-66-60B (11/08)



**LEGEND**

- A - DRAIN 1 1/2" IPS
- B - WATER INLET 3/4" IPS
- C - ELECTRICAL CONNECTION

All vertical dimensions are +/- 1/2" due to adjustable bullet feet.

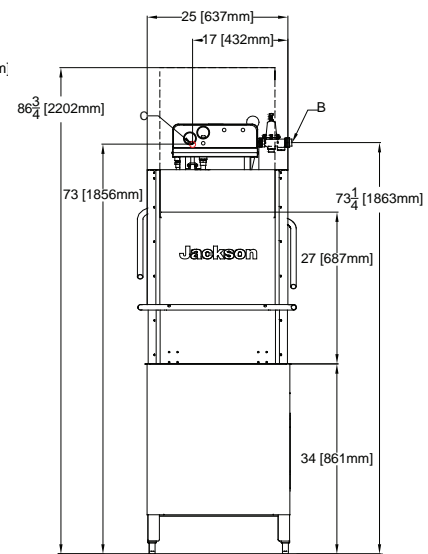
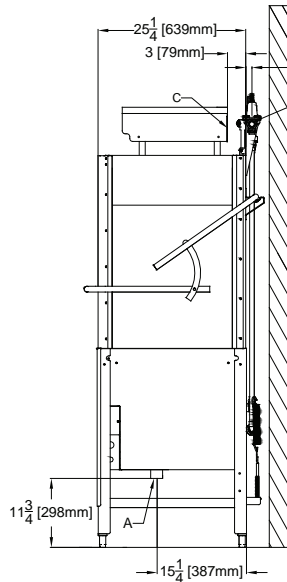
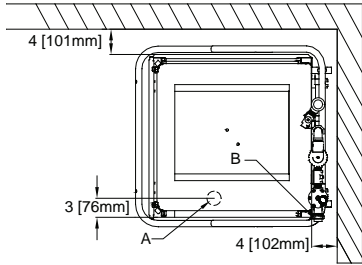

**DIMENSIONS--STANDARD MODEL**

MODEL NO.	SIZE			DRAIN HEIGHT	SHIPPING INFO			DIMENSIONS		
	HEIGHT	WIDTH	DEPTH		WEIGHT	CLASS	CUBE	HEIGHT	WIDTH	DEPTH
TempStar™HH	76-3/4" (1949 mm)	25-1/4" (641 mm)	25-1/4" (641 mm)	11-3/4" (298 mm)	420 lbs (191 kg)	92.5	71.4 cu. ft.	85" (2159 mm)	44" (1118 mm)	33" (838 mm)

**DIMENSION REQUIREMENTS**

Minimum Ceiling Height (Recommended)	88" / (2 meters)
Wall Clearance (Minimum)	4" / (102 mm)
Standard Table Height	34" / (864 mm)
Inside Clearance	17-1/4" / (438 mm)

**STEAM REQUIREMENTS**

Steam Flow Pressure (PSIG)	15-20
Consumption @ 15 PSIG (lbs/hr)	45

**OPERATING CAPACITY**

Racks per Hour	Normal 53	Medium 28	Heavy 19	Extra Heavy 11
OPERATING CYCLE (sec)	Wash	Rinse	Dwell	Total Cycle
Normal	45	15	2	62
Medium	103	15	2	120
Heavy	163	15	2	180
Extra Heavy	283	15	2	300

**WATER REQUIREMENTS**

Inlet Temperature	
40°F / (4°C) Rise	140°F / (82°C)
70°F / (21°C) Rise	110°F / (60°C)
Gallons per hour	72.1 / 273 Ltr.
Gallons per rack	1.36 / 5 Ltr
Waterline Size IPS (Minimum-inches)	3/4
Drainline Size IPS (Minimum-Inches)	1-1/2
Waterline Flow Rate (GPM)	5.44
Flow Pressure (PSI)	15-25
Tank Capacity	3 gals / (11 ltrs)
Wash Tank	8 Gal. / (30 ltr)
Booster Tank	3 Gal. / (11 ltr)

**OPERATING TEMPERATURES**

Wash (Minimum)	150°F / (66°C)
Rinse (Minimum)	180°F / (82°C)

**WASH PUMP MOTOR**

Wash Pump Motor Horsepower	2 HP		
	Volts	KW	
Electric Wash Tank Heater	208V	4.1	
	230V	5.0	
	460V	5.0	
Electric Rinse Tank Heater	40°F (4°C) Rise	208V	9.0
		230V	11.0
		460V	11.0
	70°F (21°C) Rise	208V	10.5
		230V	12.9
		460V	12.9

**APPROXIMATE LOAD AMPS**

	No Booster	40°F (4°C) Rise	70°F (21°C) Rise
Power Supply	AMPS	AMPS	AMPS
208V/60HZ/1PH	31	74.2	81.4
208V/60HZ/3PH	23	47.6	51.8
230V/60HZ/1PH	33	80.9	89.0
230V/60HZ/3PH	24	51.4	56.2
460V/60HZ/3PH	10	23.4	25.8

How To Specify - TempStar™ HH

**SHIPPING ADDRESS**  
6209 North U.S. Highway 25E  
Gray, KY 40734

**MAILING ADDRESS**  
P. O. Box 1060  
Barbourville, KY 40906

**Tel: 606-523-9795**  
**Tel: 1-888-800-5672**  
**Fax: 606-523-1799**

**www.jacksonmsc.com**  
**E-mail: customerservice@jacksonmsc.com**  
**07610-002-66-60B (11/08)**



## Free Manuals Download Website

<http://myh66.com>

<http://usermanuals.us>

<http://www.somanuals.com>

<http://www.4manuals.cc>

<http://www.manual-lib.com>

<http://www.404manual.com>

<http://www.luxmanual.com>

<http://aubethermostatmanual.com>

Golf course search by state

<http://golfingnear.com>

Email search by domain

<http://emailbydomain.com>

Auto manuals search

<http://auto.somanuals.com>

TV manuals search

<http://tv.somanuals.com>