

TECHNICAL MANUAL

**INSTALLATION MANUAL FOR EXPORT UNITS
SERVICE MANUAL FOR DOMESTIC UNITS**

FOR JACKSON MODEL:

TEMPSTAR TGP



June 24, 2004
P/N 7610-001-98-99 (Revision C)

Jackson MSC, Inc.
P.O. BOX 1060
HWY. 25E
BARBOURVILLE, KY. 40906
FAX (606) 523-9196
PHONE (606) 523-9795
www.jacksonmsc.com

TABLE OF CONTENTS

GENERAL	PAGE
Specifications	1
INSTALLATION	
Unpacking.....	2
Plumbing Connections.....	2
Electrical Connections.....	2
Gas Connection.....	3
OPERATING INSTRUCTIONS	
Preparation.....	4
Power Up.....	4
Initial Fill.....	4
Preparing the Dishes.....	4
Daily Machine Preparation.....	4
Washing a Rack of Ware.....	4
Shut Down and Cleaning.....	4
OVERVIEW OF OPERATION.....	5
THERMOSTAT ADJUSTMENT PROCEDURE.....	7
AUTO-CALIBRATION PROCEDURE.....	8
ELECTRONIC CONTROL BOARD (ECB).....	9
TESTING THERMISTORS.....	10
CONTROL BOARD LED LIGHT INDICATIONS.....	11
TROUBLESHOOTING.....	12
DIMENSIONS.....	19
TABLE DIMENSIONS.....	20
PHOTOGRAPHS	
Main Assembly.....	21
Control Box Assembly-Front View.....	22
Control Box Assembly-Top View.....	23
Hood Assembly.....	24
Cantilever Arm Assembly.....	25
Tub Assembly.....	26
Back of Tub, & Drain Assembly.....	27
Lower Assembly (Right Side).....	28
Incoming Plumbing Assembly.....	29
Gas Pack Assembly.....	31
Upper Wash, & Rinse Arm Assembly.....	32
Lower Wash, & Rinse Arm Assembly.....	33
Steam Coil Assembly.....	34
Rinse Tank Assembly.....	36
Electronic Control Drawer Components.....	37
METRIC CONVERSION.....	38
SCHEMATICS	
208/240 Volt Schematic.....	39

SPECIFICATIONS OF THE TEMPSTAR TGP

PERFORMANCE/CAPABILITIES	VOLTS	PHASE	AMPS
OPERATING CAPACITY (RACKS/HOUR)	208 - 240	1	6.7
RACKS PER HOUR	57		
DISHES PER HOUR	1425		
GLASSES PER HOUR	1425		
OPERATING CYCLE (SECONDS)			
WASH TIME	45		
RINSE TIME	11		
DWELL TIME	2		
TOTAL CYCLE TIME	60		
TANK CAPACITY (GALLONS)			
WASH TANK (MINIMUM)	8.0		
BOOSTER TANK	3.0		
TANK CAPACITY (LITERS)			
WASH TANK (MINIMUM)	30.28		
BOOSTER TANK	11.36		
WASH PUMP CAPACITY			
GALLONS PER MINUTE	150		
LITERS PER MINUTE	567.81		
TEMPERATURES			
WASH ---°F (MINIMUM)	150		
WASH ---°C (MINIMUM)	65.56		
RINSE ---°F	180		
RINSE ---°C	82.22		
ELECTRICAL REQUIREMENTS			
WASH PUMP MOTOR HP	3/4		
CIRCULATOR PUMP MOTOR HP	1/12		
		WATER REQUIREMENTS	
		INLET TEMPERATURE	70 -140°F
		INLET TEMPERATURE	21.11-60°C
		GALLONS PER HOUR	52.0
		LITERS PER HOUR	196.84
		WATER LINE SIZE I.P.S. (Minimum)	3/4"
		WATER LINE SIZE I.P.S. (Minimum)	1.9 CM
		DRAIN LINE SIZE I.P.S. (Minimum)	1-1/2"
		DRAIN LINE SIZE I.P.S. (Minimum)	3.81 CM
		FLOW PRESSURE P.S.I. (Optimum)	20
		GAS REQUIREMENTS	
		BTU INPUT RATE	55,000
		INLET LINE PRESSURE (TOWN GAS)	4-6" wci
		MANIFOLD PRESSURE (MINIMUM)	.25 wci
		(MAXIMUM)	2.3 wci
		FRAME DIMENSIONS	
		WIDTH	25 3/4"
		WIDTH	65.4 CM
		DEPTH	25 1/4"
		DEPTH	64.14 CM
		HEIGHT	56 3/4"
		HEIGHT	144.15 CM
		STANDARD TABLE HEIGHT	34"
		STANDARD TABLE HEIGHT	86.36 CM
		MAXIMUM INSIDE CLEARANCE	17 1/4"
		MAXIMUM INSIDE CLEARANCE	43.82 CM
		RACKS	
		DISH 20" X 20" (50.8 CM X 50.8 CM)	OPTIONAL
		GLASS & SILVER 20" X 20" (50.8 CM X 50.8 CM)	OPTIONAL

INSTALLATION INSTRUCTIONS

VISUAL INSPECTION: Before installing the unit, check the container and machine for damage. A damaged container is an indicator that there may be some damage to the machine. If there is damage to both the container and machine, do not throw away the container. The dishmachine has been inspected and packed at the factory and is expected to arrive to you in new, undamaged condition. However, rough handling by carriers or others may result in there being damage to the unit while in transit. If such a situation occurs, do not return the unit to Jackson; instead, contact the carrier and ask them to send a representative to the site to inspect the damage to the unit and to complete an inspection report. You must contact the carrier within 48 hours of receiving the machine. Also, contact the dealer through which you purchased the unit.

UNPACKING THE DISHMACHINE: Once the machine has been removed from the container, ensure that there are no missing parts from the machine. This may not be obvious at first. If it is discovered that an item is missing, contact Jackson immediately to have the missing item shipped to you.

LEVEL THE DISHMACHINE: The dishmachine is designed to operate while being level. This is important to prevent any damage to the machine during operation and to ensure the best results when washing ware. The unit comes with adjustable bullet feet, which can be turned using a pair of channel locks or by hand if the unit can be raised safely. Ensure that the unit is level from side to side and from front to back before making any connections.

PLUMBING THE DISHMACHINE: All plumbing connections must comply with all applicable local, state, and national plumbing codes. The plumber is responsible for ensuring that the incoming water line is thoroughly flushed prior to connecting it to any component of the dishmachine. It is necessary to remove all foreign debris from the water line that may potentially get trapped in the valves or cause an obstruction. Any valves that are fouled as a result of foreign matter left in the water line, and any expenses resulting from this fouling, are not the responsibility of the manufacturer.

CONNECTING THE DRAIN LINE: The drain for the Tempstar-TGP is a gravity discharge drain. All piping from the 1 1/2" FNPT connection on the waste accumulator must be pitched (1/4" per foot) (2.083 cm per meter) to the floor or sink drain. All piping from the machine to the drain must be a minimum 1 1/2" I.P.S. and shall not be reduced. There must also be an air gap between the machine drain line and the floor sink or drain. If a grease trap is required by code, it should have a flow capacity of 5 gallons (18.93 liters) per minute.

WATER SUPPLY CONNECTION: Ensure that you have read the section entitled "PLUMBING THE DISHMACHINE" above before proceeding. Install the water supply line (3/4" pipe size minimum) to the dishmachine line strainer using copper pipe. It is recommended that a water shut-off valve be installed in the water line between the main supply and the machine to allow access for service. The water supply line is to be capable of 20 PSI "flow" pressure at the recommended temperature indicated on the data plate.

In areas where the water pressure fluctuates or is greater than the recommended pressure, it is suggested that a water pressure regulator be installed.

Do not confuse static pressure with flow pressure. Static pressure is the line pressure in a "no flow" condition (all valves and services are closed). Flow pressure is the pressure in the fill line when the fill valve is opened during the cycle.

It is also recommended that a shock absorber (not supplied with the Tempstar-TGP model) be installed in the incoming water line. This prevents line hammer (hydraulic shock), induced by the solenoid valve as it operates, from causing damage to the equipment.

PLUMBING CHECK: Slowly turn on the water supply to the machine after the incoming fill line and the drain line have been installed. Check for any leaks and repair as required. All leaks must be repaired prior to placing the machine in operation.

ELECTRICAL POWER CONNECTION: Electrical and grounding connections must comply with the applicable portions of the National Electrical Code ANSI/NFPA 70 (latest edition) and/or other electrical codes.

Disconnect electrical power supply and place a tag at the disconnect switch to indicate that you are working on the circuit.

The dishmachine data plate is located on the right side and to the front of the machine. Refer to the data plate for machine operating requirements, machine voltage, total amperage load and serial number.

To install the incoming power lines, open the control box. This will require taking a phillips head screwdriver and removing the one(1) screw on the front cover of the control box. Install 3/4" conduit into the pre-punched holes in the back of the control box. Route power wires and connect to power block and grounding lug. Install the service wires (L1 &L2) to the appropriate terminals as they are marked on the terminal block. Install the grounding wire into the lug provided. Tighten the connections and perform the "pull test". The tightened wires should remain in place after giving the wires a moderate pull to see if they will come loose.

It is recommended that "DE-OX" or another similar anti-oxidation agent be used on all power connections.

VOLTAGE CHECK: Ensure that the power switch is in the OFF position and apply power to the dishmachine. Check the incoming power at the terminal block and ensure it corresponds to the voltage listed on the data plate. If not, contact a qualified service agency to examine the problem. Do not run the dishmachine if the voltage is too high or too low. Shut off the service breaker and mark it as being for the dishmachine. Advise all proper personnel of any problems and of the location of the service breaker. Replace the control box cover and tighten down the screws.

GAS CONNECTION

It is very important that the type and inlet pressure of the gas used corresponds to the machine data plate. This machine is equipped with a 1/2" female line for connection of gas. The gas line used should be of the type approved for use with natural gas or propane, depending on the gas selected to be used in this machine. The gas line should be sized to carry the maximum flow of 55,000 BTUs. Too small of a gas line will result in poor performance. A manual gas shut-off valve must be installed in the gas line, located within an accessible area of the machine. The gas line should be kept as short as possible and installed in a way to protect it from damage.

When making pipe connections, use an AGA approved pipe dope, being careful not to use excessive amounts as to foul the gas valve or clog the gas line. When tightening the gas line always support the gas valve to avoid damage to the gas train.

When making the connection to the booster unit, take care to start the gas line fitting by hand and tighten by hand to avoid cross threading. Tighten fitting with a wrench, taking care not to damage any internal components of the unit.

After making a final connection of gas, with power to the unit turned off, check all gas line fittings for leaks, using a liquid test solution.

WARNING

ENSURE THAT THERE IS NO ELECTRICAL POWER APPLIED TO THE MACHINE WHEN MAKING GAS CONNECTION.

CHECK ALL GAS CONNECTIONS FOR LEAKS PRIOR TO APPLYING POWER.

**THE GASES USED FOR COMBUSTION IN THIS DISH MACHINE ARE HIGHLY FLAMMABLE.
DO NOT SMOKE AROUND THIS MACHINE.**

ENSURE THAT THE AREA WHERE THIS MACHINE IS TO BE INSTALLED IS WELL-VENTILATED TO PREVENT THE BUILD-UP OF COMBUSTIBLE GASES.

ENSURE THAT ALL LOCAL HEALTH, FIRE, AND BUILDING CODES ARE BEING ADHERED TO WHEN INSTALLING THIS MACHINE. VERIFY WITH LOCAL OFFICIALS IF THERE ARE ANY QUESTIONS.

INSTALL A SHUT-OFF VALVE AT THE GAS SOURCE AND SUPPLY THE MACHINE USING A 1/2" LINE. CONNECT TO THE 1/2" NPT FITTING ON THE MACHINE.

OPERATION INSTRUCTIONS

PREPARATION: Before proceeding with the start-up of the unit, verify the following:

1. The pump intake, and wash tank strainers are in place and is clean.
2. The drain stopper is installed.
3. That the wash and rinse arms are screwed securely into place and that their endcaps are tight. The wash and rinse arms should rotate freely.

POWER UP: To energize the unit, turn on the power at the service breaker. The voltage should have been previously verified as being correct. If not, the voltage will have to be verified.

FILLING THE WASH TUB: Ensure that the delime switch is in the NORMAL position, and place the power switch into the ON position. The Tempstar-TGP should fill automatically and shut off when the appropriate level is reached (just below the wash tank strainer). Verify that the drain stopper is preventing the wash tub water from pouring out excessively. There will probably be some slight leakage from the drain hole. Verify that there are no other leaks on the unit before proceeding any further. The wash tub must be completely filled before operating the wash pump to prevent damage to the component. Once the wash tub is filled, the unit is ready for operation.

The water level was set at the factory. If the water level is not at the level noted above, it will require adjustment. Check to ensure that the recommended water pressure is being supplied to the machine (20 PSI). If the water pressure is correct then the fill valve will need adjustment. Use the following steps to adjust the cam. Turn power off at the machine circuit breaker. Open the control box cover. Locate the timer fill valve cam (Cam 4 from the timer motor). Locate the spanner wrench taped to the electrical panel. The spanner wrench is used to adjust the cam.

WARE PREPARATION: Proper preparation of ware will help ensure good results and less re-washes. If not done properly, ware may not come out clean and the efficiency of the dish-machine will be reduced. It is important to remember that a dish-machine is not a garbage disposal and that simply throwing unscrapped dishes into the machine simply defeats the purpose altogether of washing the ware. Scraps should be removed from ware prior to being loaded into a rack.

Pre-rinsing and pre-soaking are recommended, especially for silverware and casserole dishes. Place cups and glasses upside down in racks so that they do not hold water during the cycle. The dish-machine is meant not only to clean, but to sanitize as well, to destroy all of the bacteria that could be harmful to human beings. In order to do this, ware must be properly prepared prior to being placed in the machine.

DAILY MACHINE PREPARATION: Refer to the section entitled "PREPARATION" at the top of this page and follow the instructions there. Afterwards, check that all of the chemical levels are correct and/or that there is plenty of detergent available for the expected workload.

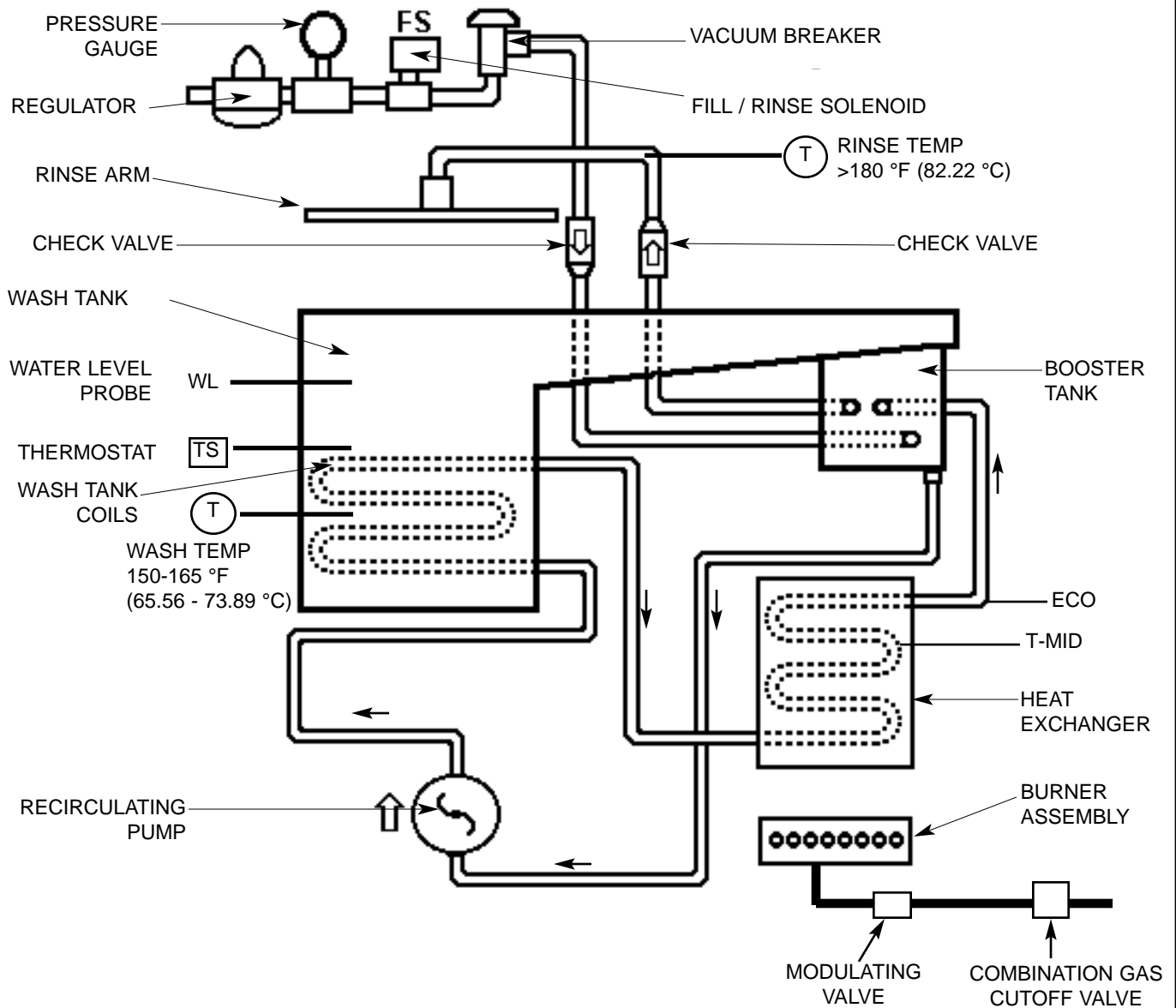
WARM-UP CYCLES: For a typical daily start-up, it is recommended to run the machine through 3 cycles to ensure that all of the cold water is out of the system and to verify that the unit is operating correctly. To cycle the machine, ensure that the power is on and that the tub has filled to the correct level. Lift the doors and the cycle light will illuminate. When the light goes out, close the doors, the unit will start, run through the cycle, and shut off automatically. Repeat this two more times. The unit should now be ready to proceed with the washing of ware.

WASHING A RACK OF WARE: To wash a rack, open the doors completely (being careful for hot water that may drip from the doors) and slide the rack into the unit. Close the doors and the unit will start automatically. Once the cycle is completed, open the door (again watching for the dripping hot water) and remove the rack of clean ware. Replace with a rack of soiled ware and close the doors. The process will then repeat itself.

OPERATIONAL INSPECTION: Based upon usage, the wash tank strainer may become clogged with soil and debris as the workday progresses. Operators should regularly inspect the wash tank strainer to ensure it has not become clogged. If the strainer does, it will reduce the washing capability of the machine. Instruct operators to clean out the wash tank strainer at regular intervals or as required by work load.

SHUTDOWN AND CLEANING: At the end of the workday, close the doors. When the unit completes the cycle, turn the power switch to the OFF position and open the doors. Manually remove the drain stopper from the tub and allow the tub to drain (NOTE: the wash tank water will be hot so caution is advised). Once the wash tub is drained, remove the wash tank strainer and the pump suction strainer. Remove soil and debris from the strainer and set to the side. Unscrew the wash and rinse arms from their manifolds. Remove the endcaps and flush the arms with water. Use a brush to clean out the inside of the arms. If the nozzles appear to be clogged, use a toothpick to remove the obstruction. Wipe the inside of the unit out, removing all soil and scraps. Reassemble the wash and rinse arms and replace them in the unit. The arms only need to be hand tight, do not use tools to tighten them down. Reinstall the strainers and close the doors.

OVERVIEW OF OPERATION



The Tempstar TGP heating system is designed to heat and maintain the wash tank water temperature at a minimum of 150 °F (65.56 °C) as well as providing a constant 180 °F (82.22 °C) rinse water temperature. Incoming water is supplied at a pressure of 20psi and between 70-140 °F (21.11 - 60 °C). Incoming gas pressure should be between 4.0-6.0 WCI for town gas. The sequence of operation is as follows (please refer to the above diagram):

When the power is turned on at the ON/OFF switch the water level control board will sense a low water level in the wash tank and the unit will begin to fill. This occurs as the rinse solenoid valve opens, allowing connected water to fill the booster tank, heat exchanger and the rest of recirculating system, once the booster tank is full, water will fill the wash tank until the water level control system is satisfied. Simultaneously with the fill, the rinse recirculating pump and the gas burner assembly is energized, to begin heat up of the unit. A transformer in the main control box supplies +12vdc to the electronics control drawer location in the lower section of the unit. The electronics control board (ECB) is the brain of the system. The ECB receives various inputs and determines the amount of heating required.

When energized the ECB receives input from the T-mid thermistor indicating a low water temperature in the recirculating system. The ECB will power the ignition relay on the board, which in turn provides +12vdc to the direct spark ignition board (DSI). The DSI sends +12vdc to the combination gas cutoff valve to open it. This will supply gas to the burner assembly. The DSI begins sparking the igniter probe, and monitors the flames presence. If the flame is not sensed during the ignition attempt, then the DSI will lockout until the software resets the DSI approximately 60 seconds later.

OVERVIEW OF OPERATION (CONTINUED)

The operator may turn the power off at the ON/OFF switch for approximately 5 seconds, and then back on. This will also reset the ECB and the DSI. If flame is lost during normal burn, the DSI will attempt a reignition.

The ECB monitors the 12vdc signal from the DSI to the combination gas cutoff valve. The software in the ECB also reads the temperature at the middle of the heat exchanger with the T-mid thermistor. After the 5.5 second ignition time, the software will increase gas flow to the burner to minimum burn by increasing voltage to the modulating valve (MV). If the heat exchanger temperature is far away from the stabilization temperature, the software will increase gas flow to maximum burn.

Once the heat exchanger temperature nears the stabilization temperature the gas flow is slowly reduced until the minimum burn is attained. The software will keep the unit in minimum burn until the heat exchanger temperature exceeds stabilization temperature when the gas will be shut off. Over many minutes, the software will turn the burner off and on repeatedly until all the water in the system reaches the stabilization temperature. At this point the software will only turn the burner on every 1-2 minutes to maintain the stabilization temperature. Now the unit is ready for operation.

As the dishwasher pulls water from the tank, the water is replaced with cooler water. The need to heat the new water is sensed by the software and the burner is turned on. The software will modulate the gas flow between minimum and maximum gas flow attempting to recover the stabilization temperature and always keeping the tank temperature above the required temperature.

The stabilization temperature may be adjusted by means of a potentiometer located on the ECB. This is referred to as the T-set. (normally 4.25vdc)

The recirculating pump draws water from the rinse booster tank and circulates it through the wash tank coils where it will heat the water residing in the wash tank. The water then returns to the heat exchanger where it is reheated. This hot water then flows back to the rinse booster tank and repeats the cycle.

The thermostat,(in conjunction with the wash temp relay) is used during idle times to prevent wash tank temperature from exceeding 170° F (76.67°C), during normal operation the wash tank will self regulate between 150-165° F (65.56-73.89 °C). However, when idle, the temperature in the wash tank will slowly rise towards booster tank temperature until the temperature reaches 170° F (76.67°C). The wash tank thermostat will cycle the heat exchanger & recirculating pump off. When the wash tank temperature lowers, the heat exchanger and recirculating pump will energize. This will continue during all idle time. At any time that the unit is placed into operation, the wash temp relay will energize and immediately power the heat exchanger and the recirculating pump, regardless of the thermostats position.

Excessive high temperatures in the system are avoided by the following: 1. high temperature limit control by input from T-mid thermistor, 2. energy cutoff temperature lockout (ECO) by means of a bi-metallic switch independent of the microprocessor which will break voltage to the combination gas cutoff valve if temperature in the system exceeds 210 F (98.89°C).

Excessive high pressures that potentially could be created in the system are vented directly to atmosphere by means of the rinse booster tank and rinse arms.

THERMOSTAT ADJUSTMENT PROCEDURE

- 1) Start up unit
- 2) Allow to fill, and start warm-up
- 3) Turn thermostat trim screw Counter Clockwise (CCW) 2 full revolutions
- 4) Allow wash temperature to reach 170° F on Wash Temperature Gauge
- 5) Turn thermostat trim screw Clockwise (CW) until flashing Green LED on control board turns off. (The recirculating pump will also turn off).
- 6) To ensure that the trim screw has not been turned too far CW, turn CCW very slowly until Green LED turns on and once again turn CW very slowly until Green LED goes out.
- 7) Start normal operation and monitor wash tank temperature.
- 8) If readjustment is needed repeat steps 5 - 7 until wash tank temperature maintains at 170°F (76.67°C), during idle time.

AUTO-CALIBRATION PROCEDURE

Model: TEMPSTAR GP, & TEMPSTAR TGP

This procedure must be completed every time you replace either a control board or a modulating valve.

AUTO - CALIBRATION

1. Turn the unit OFF at the main power switch and let stand for one minute.
2. Remove the lower front panel and set aside.
3. Remove the cover of the rectangular control box.
4. Locate the control board (see figure 1).
5. Locate and remove the jumper labeled ACAL (see figure 1) from the control board. Be careful to remove metal jumper not just the plastic insulator. Make a note of the exact position the jumper was located. Set jumper aside for later reinstallation.
6. With your multi-meter set on DC volts, attach to the molex plug going to the modulating valve.
NOTE: Do not disconnect molex plug. Insert probes in the rear of one side so the contact is made with the metal pins inside of the plug. (see figure 2).
7. Turn dishmachine ON. Burner will ignite and run through a series of steps. Watch the readings of your multi-meter. They will run approximately 11.9 VDC (23 VDC for the TGP) at the highest flame, step down to about 6.0 VDC (12 VDC for the TGP) and then step down again slightly to 5.7 to 5.8 VDC (11.4 to 11.6 VDC for the TGP) before shutting the burner off. This whole process takes about 1 - 2 Minutes.
8. Once the burner goes out, turn dishmachine OFF.
9. Wait one minute.
10. Replace jumper on control board in the exact same place it came off.
11. Turn the dishmachine back ON.

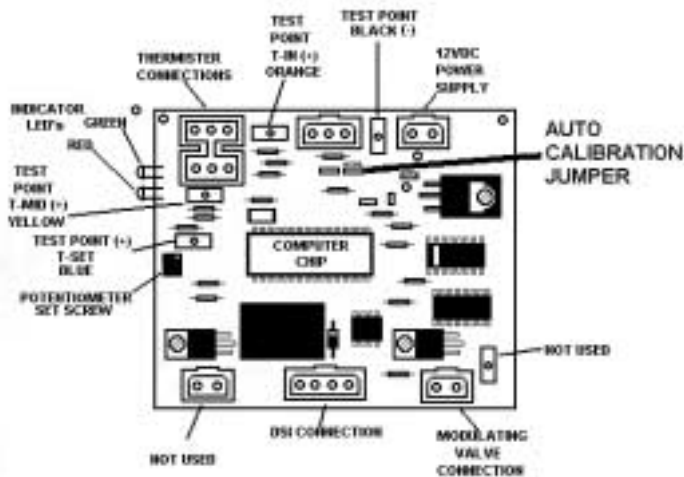


Figure 1

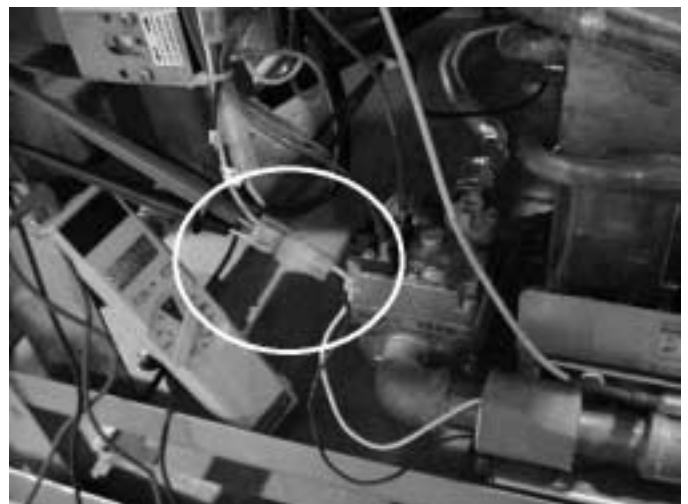
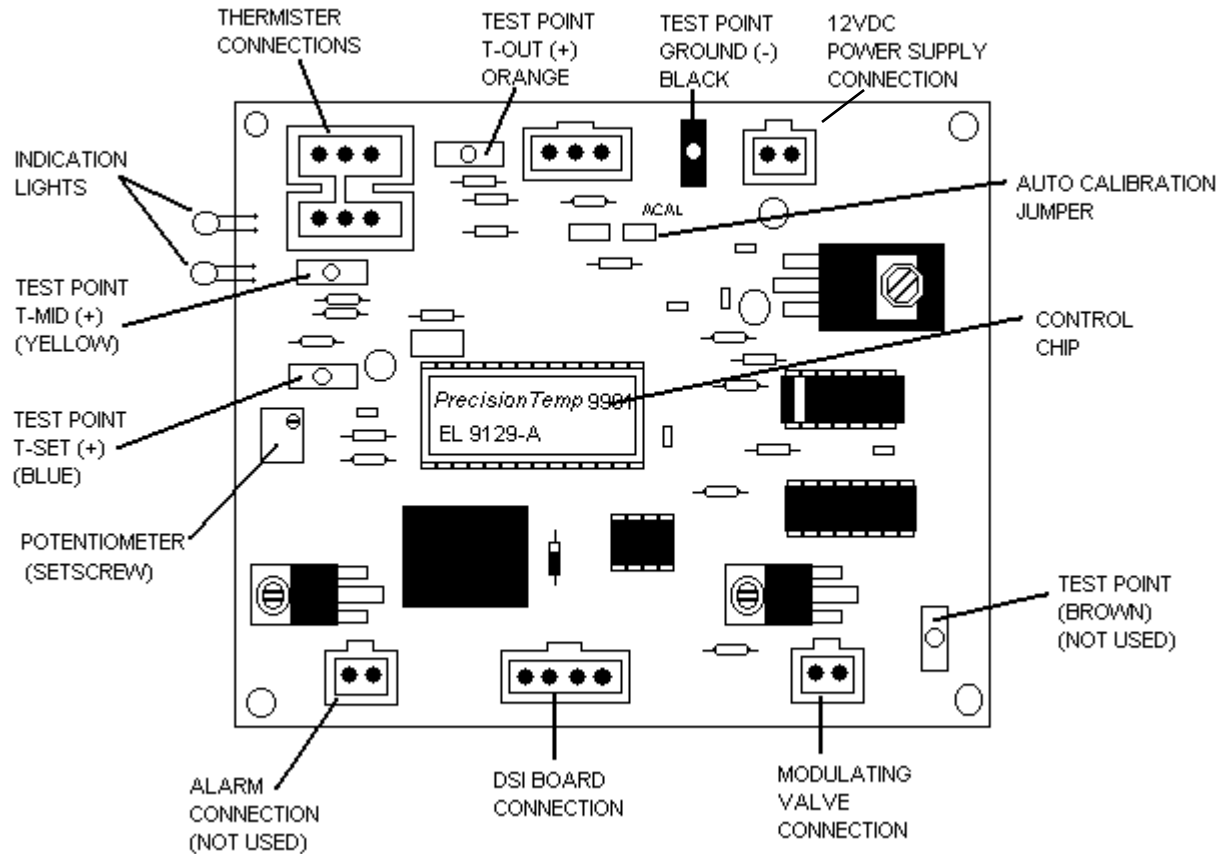


Figure 2

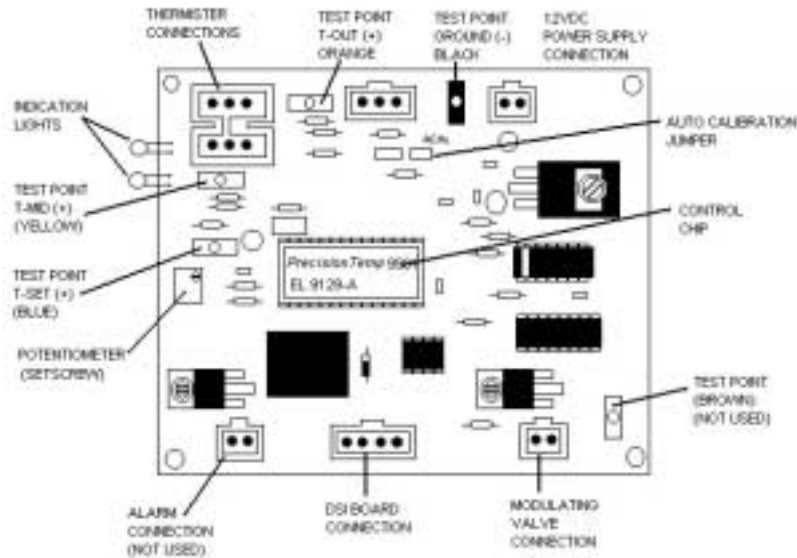
ELECTRONICS CONTROL BOARD (ECB)



Testing and Setting the Set Point Temperature

The Control Board regulates the temperature of the water in the heat exchanger system. This water is also used as the rinse water for the rinse cycle of the dishwasher. It does this by regulating the flame of the burner by increasing or decreasing the voltage to the modulating valve. The modulating valve, in turn, increases or decreases the gas pressure going to the burner manifold depending on the voltage it is getting from the control board. From time to time it may be necessary to check or adjust the setting of this water temperature. To test the setting or to reset the temperature of the rinse water, make sure the unit is on and the green LED on the board is flashing steadily. Insert the NEGATIVE (Black/Common) probe of a multi-meter set on DC volts in the BLACK test point (see above). Insert the POSITIVE (Red) probe of the multi-meter in the BLUE test point. The reading will indicate the set point temperature. The factory setting is **4.25 VDC** which corresponds to 198°F (92°C). Adjustments to the set point are made on the BLUE POTENTIOMETER directly below the BLUE test point. With a very small slotted screwdriver rotate the trim screw on the potentiometer clockwise (CW) to increase the voltage (and Temperature) and counterclockwise to decrease.

TESTING THE THERMISTORS



There are two thermistors that are used in controlling the temperature of the water in the heat exchanger system. The T- in that samples the temperature of the water going into the heat exchanger and the T-Mid that samples the temperature halfway through the heat exchanger. The Control Board constantly monitors the temperature at the T-Mid Thermistor and adjusts the burner pressure by way of the Modulating Valve according to how far away that temperature is away from the set point temperature.

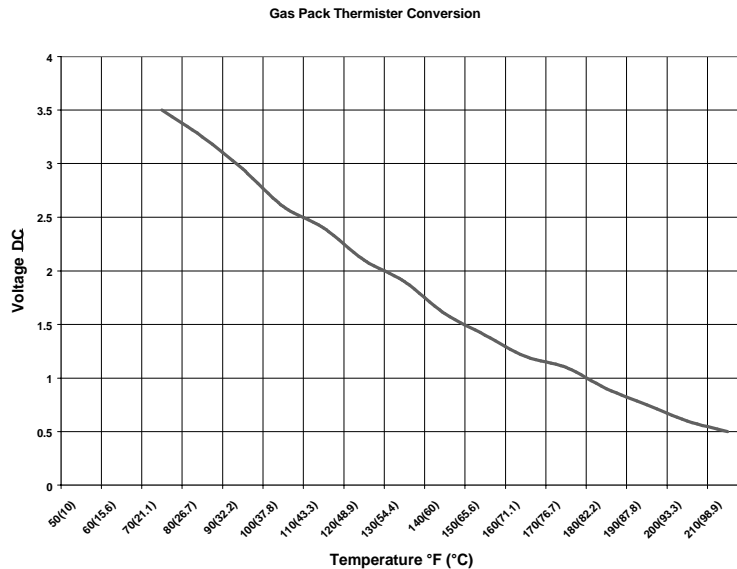
Thermistors are devices that change their resistance value with changes in temperature. By running a constant voltage through the thermistor, one can read the change of voltage caused by the change of resistance thus determining the temperature of the thermistor. There are test points on the control board (see above) that can be read with a multi-meter on the Direct Current Volt (DCV) scale for each thermistor.

To test the temperature at the T-in Thermistor

There is a BLACK test point along the top edge of the control board on the right side of center. This is where the NEGATIVE (Common/Black) probe of a multi-meter is inserted. There is an ORANGE test point along the top edge of the control board on the left side of center. This is where the POSITIVE (Red) probe of a multi-meter is inserted. A DC voltage reading is then taken. Find the voltage on the chart below and find the corresponding temperature.

To test the temperature at the T-Mid Thermistor

Using the same BLACK test point with the NEGATIVE probe of the multi-meters in testing the T-in thermistor above, also find the YELLOW test point on the left side of the board just under the large plug (see above). Insert the positive probe of the multi-meter and read DC Volts. Since the two thermistors have the same values, the same chart is used.



CONTROL BOARD LED LIGHT INDICATIONS

The Electronic Control Board (ECB) has two LED light indicators that can be seen at its upper left hand corner. The following conditions for each light may be seen during operation of the unit.

1) Green LED is off.

- A) Dishmachine is turned off, therefore no power to ECB.
- B) Wash thermostat has cycled off, therefore breaking power to 12 volt transformer in the main control box. This will also disrupt power to the ECB.
- C) ECB may have never recieved an AUTO CALIBRATION.
- D) ECB may be damaged due to high voltage.
- E) Control chip in ECB may be misaligned, not fully inserted, or damaged.

2) Green LED is a illuminated and steady.

- A) ECB has been damaged in some form.

3) Green LED is illuminated and flashing.

- A) This is the normal operating condition.(whether the LED flashes rapidly, or at a slower rate).

4) Red LED is off.

- A) This is the normal operating condition.

5) Red LED is illuminated and steady, or flashing.

- A) This is an indication of a malfunction of the T-MID Thermistor. Thermister may be unplugged, grounded, have frayed wiring, or other damage.

TROUBLESHOOTING SECTION

WARNING: Inspection, testing and repair of electrical equipment should only be performed by a qualified service technician. Many of the tests require that the unit have power to it and live electrical components be exposed. **USE EXTREME CAUTION WHEN TESTING THE MACHINE.**

Symptom	Possible Cause	Action
Dishmachine will not run. No power to the unit.	Service breaker tripped.	Reset breaker. If breaker trips again, immediately contact an electrician.
	Incoming power lines not installed in control box.	Install power lines.
	Incoming power lines connections not tightened.	Tighten connections.
Dishmachine will not run. There is power to the unit.	Door switch shorted out or is disconnected.	Check to ensure door switch wires are connected correctly. If so, replace door switch.
	Misadjusted or faulty "cycle reset" cam microswitch.	Replace microswitch.
Machine runs, but there is not water.	No water supply to machine.	Check to ensure that all water valves are open and that water is being supplied to the machine at 20 PSI.
	Incoming water supply solenoid not operating.	Check to ensure that valve is wired correctly. If so, replace valve.
Dishmachine fills continuously, even when the machine is off.	Incoming water supply solenoid not operating.	Check to ensure that valve is wired correctly. If so, replace valve.
Dishmachine fills continuously, only when the power is on.	Incoming water supply solenoid not operating.	Check to ensure that valve is wired correctly. If so, replace valve.

TROUBLESHOOTING SECTION

WARNING: Inspection, testing and repair of electrical equipment should only be performed by a qualified service technician. Many of the tests require that the unit have power to it and live electrical components be exposed. **USE EXTREME CAUTION WHEN TESTING THE MACHINE.**

Symptom	Possible Cause	Action
Dishmachine fills continuously, only when the power is on.	Faulty fill microswitch.	Replace microswitch.
	Cam timer stalled in fill position.	If cam timer is not rotating, check the voltage to the motor. If voltage is correct, replace timer.
	Shorted out ON/FILL switch.	Check the voltage across the switch. If the voltage is incorrect, replace the switch.
	Shorted/defective liquid level control board or probe.	Check voltage going to each component and ensure they are wired correctly. If satisfactory, replace the defective part.
Dishmachine runs with the door open.	Door switch shorted out/wired incorrectly.	Check the wiring of the door switch, if correct, replace the door switch.
	Faulty wash relay (wash relay welded closed).	Turn machine off, if wash relay doesn't release, replace contactor.
	Faulty control relay.	Measure the continuity between terminals # 6 and #9. If there is no continuity, replace the relay.
Low wash water pressure.	Water level is too low.	Check to ensure that the drain stopper is in and has an O-ring. Check to ensure that the LLC board and probe are functioning properly.
	Pump intake strainer is clogged.	Remove and clean strainer.

TROUBLESHOOTING SECTION

WARNING: Inspection, testing and repair of electrical equipment should only be performed by a qualified service technician. Many of the tests require that the unit have power to it and live electrical components be exposed. **USE EXTREME CAUTION WHEN TESTING THE MACHINE.**

Symptom	Possible Cause	Action
Low wash water pressure.	Wash arms (nozzles) are clogged.	Remove wash arms and clean.
	Pump impeller worn or broken.	Replace pump.
Water leak in the gas booster pack.	Loose compression or NPT fitting.	Check all fittings to ensure that they are tight.
	Compression fitting over-compressed.	Replace compression fitting.
	NPT fitting cross-threaded.	Replace the fitting.
Gas leak. CAUTION: WHEN CHECKING FOR GAS LEAKS DO NOT USE FLAME.	Loose fitting.	Using an approved leak detector, determine which fitting is loose and either tighten or replace.
	Bad thread sealer on fitting.	Remove fitting and apply an AGA approved thread sealer.
	Defective part (has crack, hole, or break in it)	Replace the part.
Low rinse temperature/low wash temperature.	Excessive water flow into machine.	Adjust pressure regulator so that 20 PSI is maintained at gauge. Check for leakage past solenoid valve.

TROUBLESHOOTING SECTION

WARNING: Inspection, testing and repair of electrical equipment should only be performed by a qualified service technician. Many of the tests require that the unit have power to it and live electrical components be exposed. **USE EXTREME CAUTION WHEN TESTING THE MACHINE.**

Symptom	Possible Cause	Action
Low rinse temperature/low wash temperature.	Low inlet water temperature.	Ensure incoming water is 110 F (43.33 C) at incoming point of machine, may need to increase the set point of the supply water heater.
	Low gas pressure.	Check gas supply pressure.
		Ensure proper operation of combination gas cutoff valve.
		Ensure manual gas cutoff valve is open.
		Check gas supply pressure.
	Improper circulation through system.	Check for kinks in flexible gas supply line.
		Check recirculating pump operation. Check for obstructions.
T-set needs adjustment.	Ensure set point is approximately 4.25 VDC.	
Defective T-mid thermistor (Red LED light may be flashing).	Check Ohms reading is between 950 and 1150 Ohms when probe is at room temperature. Check for frayed wiring. Ensure connection to control board.	
	Defective control board (ECB).	Perform auto-calibration. Ensure power supplied to board is +12 VDC. Ensure green LED light is flashing.
High rinse temperature.	T-set needs adjustment.	Ensure set point is approximately 4.25 VDC.
	ECO failure. (Overprotection feature is faulty and does not open at 210 F) (98.89 C).	Remove wire from ECO terminal. If burner unit turns off, ECO may be defective. Replace ECO.

TROUBLESHOOTING SECTION

WARNING: Inspection, testing and repair of electrical equipment should only be performed by a qualified service technician. Many of the tests require that the unit have power to it and live electrical components be exposed. **USE EXTREME CAUTION WHEN TESTING THE MACHINE.**

Symptom	Possible Cause	Action
High wash tank temperature.	Defective thermostat.	If wash tank temperature is greater than 170 F (76.67 C), back thermostat CCW one full turn and restart unit. When cycle completes, set thermostat to 170 F (76.67 C) by turning CW.
	Leak in wash tank heating coil, allowing hot recirculating system water to enter tank.	Empty wash tank and observe coils with recirculating system on.
No Green LED flash and the recirculating pump is running or the Green LED stays on, but does not flash.	New control board placed into system and not calibrated.	Perform auto-calibration.
	Power to control board interrupted.	Check +12 VDC to control board (Voltage should be between 10.8 and 14.4 VDC). Make sure the transformer in main control box is energized. CAUTION: REVERSE POLARITY WILL DAMAGE THE CIRCUIT BOARDS.
	Circuit chip (microprocessor) pins not fully inserted into its sockets.	Check for bent pins. Ensure chip fully inserted by gently pressing with thumb.
Green LED flashes, but no ignition attempt (no igniter, no gas).	T-mid thermistor reading incorrectly. (May be sensing non-existing high temperature.)	Check T-mid voltage reading at test points on control board.
	Ignition relay on control board inoperative.	Place finger on ignition relay and turn power on. Should hear or feel the relay actuating. If not, check circuit chip (microprocessor) fully inserted. If so, replace control board.
	Voltage not being sent from control board to DSI.	Check for 12 VDC at black wire going from control board to DSI. Ensure green wire on DSI cable is grounded.
Green LED flashes, but no ignition. (Igniter sparks, no gas)	ECO defective or not electrically connected.	Check blue wire from DSI connected to one spade terminal of ECO and another blue wire connected from other spade terminal of ECO and to the combination gas cutoff valve.

TROUBLESHOOTING SECTION

WARNING: Inspection, testing and repair of electrical equipment should only be performed by a qualified service technician. Many of the tests require that the unit have power to it and live electrical components be exposed. **USE EXTREME CAUTION WHEN TESTING THE MACHINE.**

Symptom	Possible Cause	Action
Green LED flashes, but no ignition (igniter sparks, no gas).	Gas flow interrupted.	Check manual gas valve is open.
		Check regulated gas pressure. (4.0 -6.0 WCI) for town gas.
		If gas line diameter is less than 1/2" (1.27cm) or gas line greater than 16 feet (4.88m), reduce pressure may result.
	Combination gas cutoff valve is closed.	Ensure 12 VDC to both sides of valve. If not, check ECO and DSI. If yes, valve may have failed shut. Replace valve.
Green LED flashes, but no ignition (no igniter sparks, gas flow and smell present).	Modulating valve forced out of normal range and may be stuck (common occurrence during shipment).	Tap on gas supply line between the combination cutoff valve and the modulating valve. This tapping helps to free the piston.
	Ignition wire loose or broken.	Check wire for continuity. Check connection to both the DSI and spark probe.
	Improper gap on spark probe.	Check height of probe above burner (should be 1/8"(.318 CM)). Check gap between probe ends (1/8"(.318 CM)). Ensure probe is not touching burner.
The unit ignites, but will not rise above ignition burn.	Defective DSI.	Disconnect ignition wire from DSI spade connector. During ignition, a spark should be seen at this spade. If none, replace DSI. If spark exists, replace ignition wire.
	Improper operation of modulating valve.	Check voltage to modulating valve. If greater than 2.0 VDC, modulating valve may have been forced out of its operating range. Tap on gas supply line between the combination cutoff valve and the modulating valve. This tapping helps to free the piston. If less than 2.0 VDC, replace control board.

TROUBLESHOOTING SECTION

WARNING: Inspection, testing and repair of electrical equipment should only be performed by a qualified service technician. Many of the tests require that the unit have power to it and live electrical components be exposed. **USE EXTREME CAUTION WHEN TESTING THE MACHINE.**

Symptom	Possible Cause	Action
The unit ignites, but will not rise above ignition burn.	T-mid thermistor inoperative.	Check T-mid thermistor readings at control board set points.
	T-set too low.	Check T-set is at 4.25 VDC.
	Obstruction in gas burners or gas nozzles.	Remove burner manifold and check for obstructions.
	Control board damaged.	Replace control board.
Exhaust contains dark smoke.	Incorrect gas nozzles for type of gas being used.	Remove burner manifold and check correct nozzle orifice size.
	Gas leak may be present.	Check for localized large yellow flame, or a flame located above the burner.
	Obstruction in heat exchanger vent or air intake.	Check for obstructions.
Ignition attempt with flame already burning.	Flame proofing not occurring.	Check ignition wire. Check that lights above connection point to DSI are dimly lit (proofing signal is present).
Heat exchanger and recirculating pump de-energize at end of rinse cycle with wash tank temperature below 170 F (76.67 C).	Failure or incorrect setting of thermostat.	Back thermostat CCW one full turn and restart unit. When cycle completes, set thermostat to 170 F (76.67 C) by turning CW.

DIMENSIONS

LEGEND

- A** - DRAIN 1 1/2" I.P.S.
- B** - WATER INLET 3/4" I.P.S.
- C** - ELECTRICAL CONNECTION
- D** - STANDARD WALL CLEARANCE WITH DISHTABLE IS 4" (10.16cm)
- E** - GAS INLET

DIMENSIONS LEGEND

LETTER	DIM (IN)	DIM (CM)	LETTER	DIM (IN)	DIM (CM)
A	2 1/2"	6.35	K	6"	15.24
B	2 1/2"	6.35	L	9"	22.86
C	25 1/4"	64.14	M	11 1/2"	29.21
D	28"	71.12	N	16"	40.64
E	32"	81.28	O	60 3/4"	154.31
F	8"	20.32	P	11 1/2"	29.21
G	75"	190.5	Q	3 3/4"	9.53
H	60 3/4"	154.31	R	5 1/2"	13.97
I	17"	43.18	S	9"	22.86
J	34"	86.36	T	16 1/2"	41.91

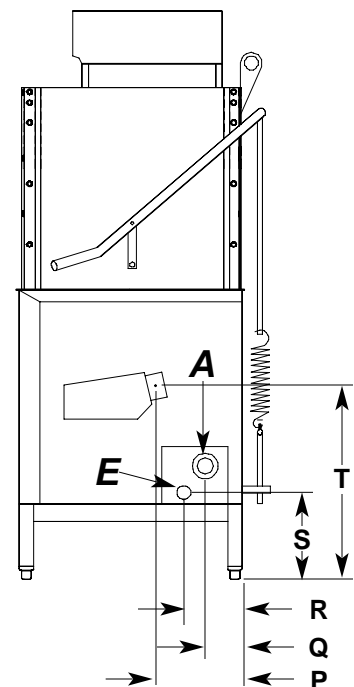
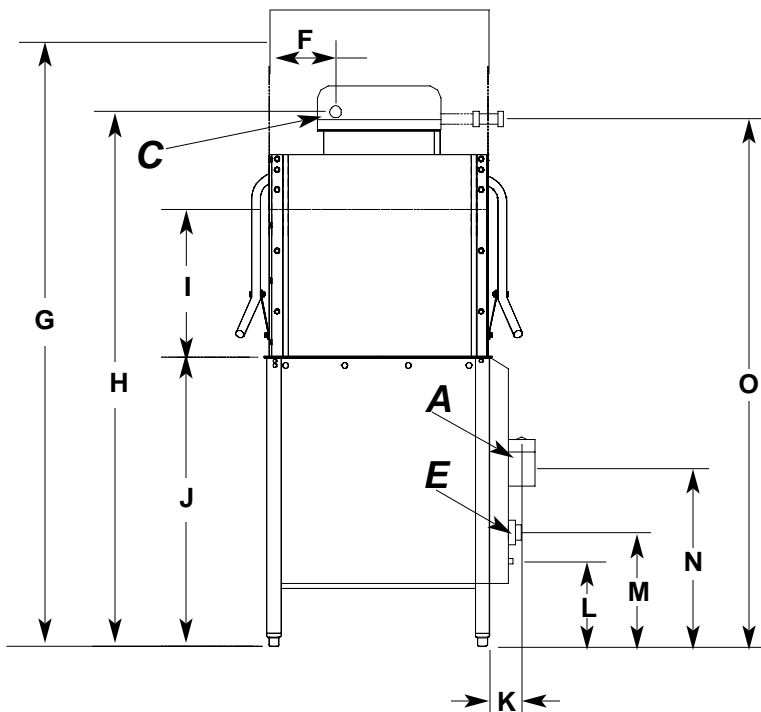
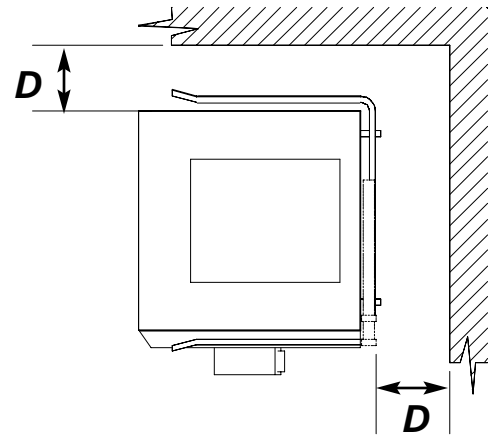
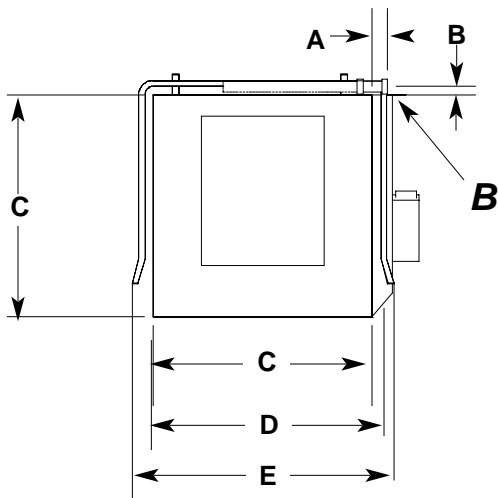
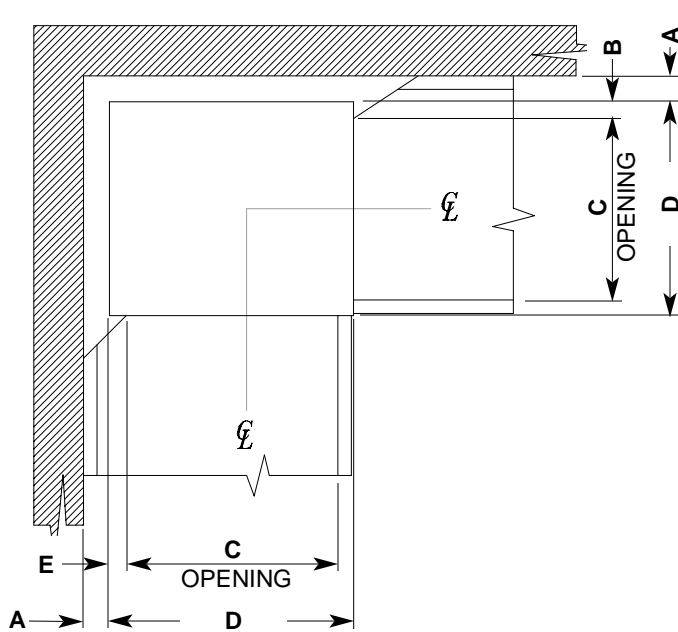
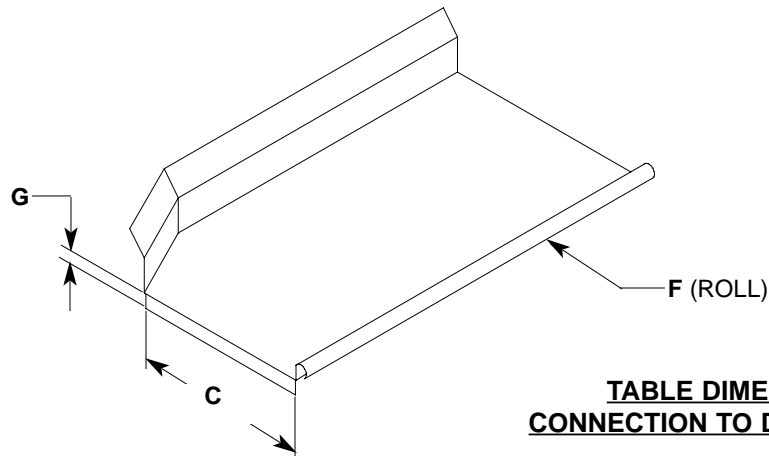


TABLE DIMENSIONS

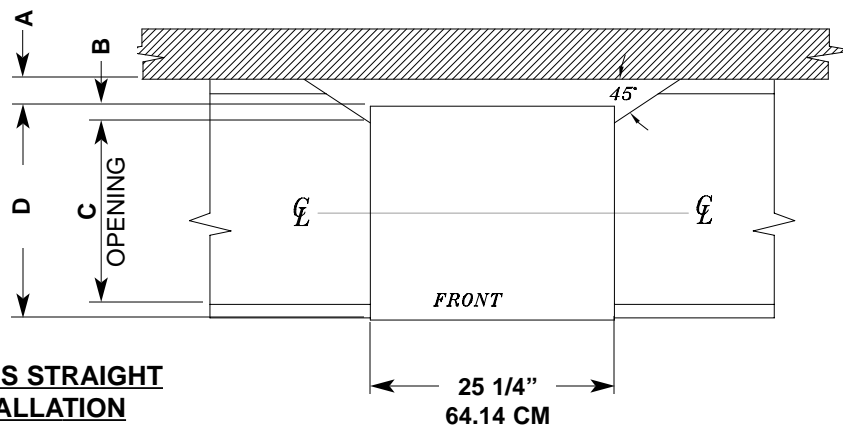


LETTER	DIM (IN)	DIM (CM)
A	4" (MIN)	10.16 (MIN)
B	2-1/2"	6.35
C	20-1/2"	52.07
D	25-1/4"	64.14
E	2-1/4"	5.72
F	1-1/2"	3.81
G	3/4"	1.91

**TABLE DIMENSIONS
CORNER INSTALLATION**

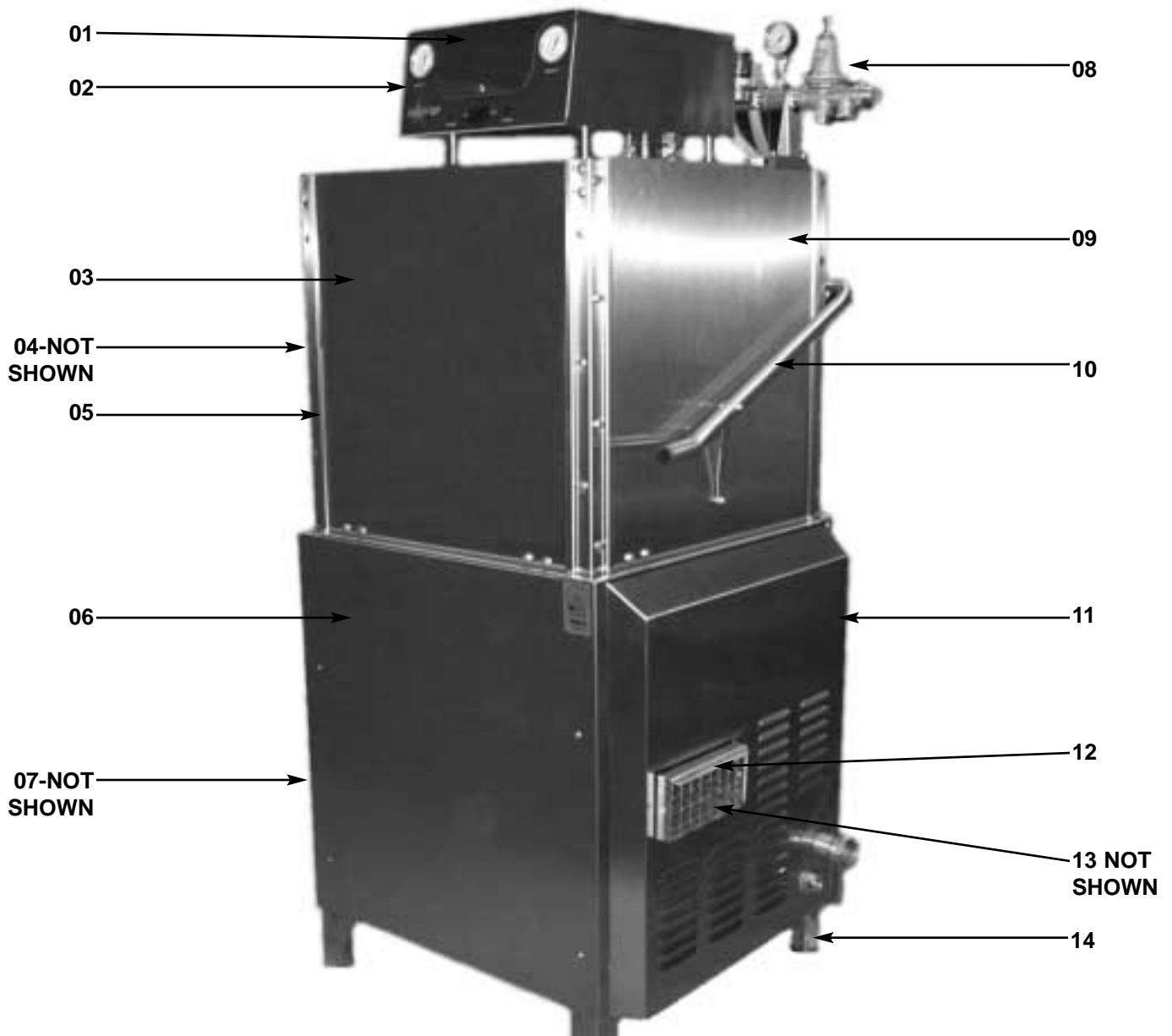


**TABLE DIMENSIONS
CONNECTION TO DISHMACHINE**



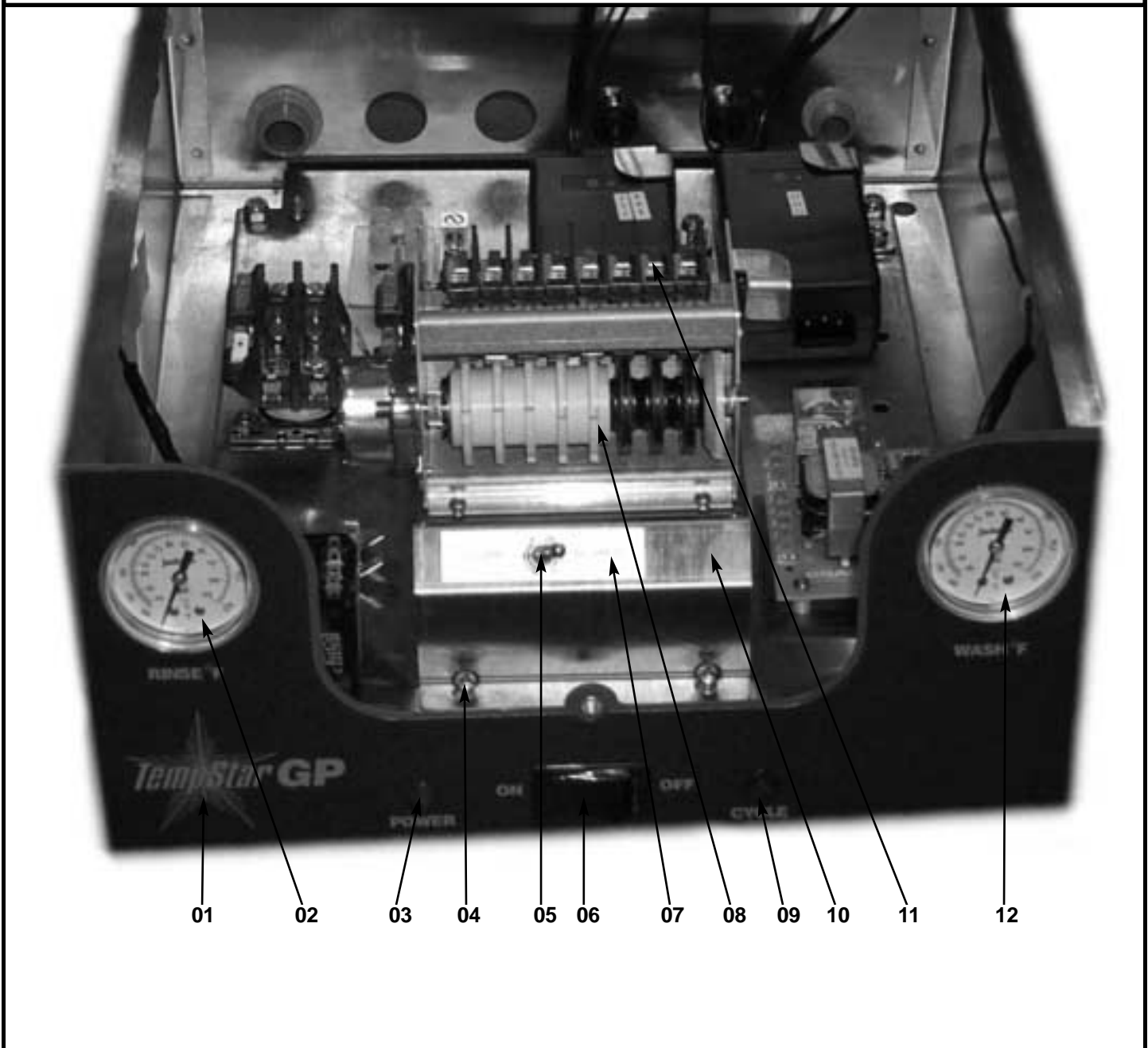
**TABLE DIMENSIONS STRAIGHT
THROUGH INSTALLATION**

MAIN ASSEMBLY



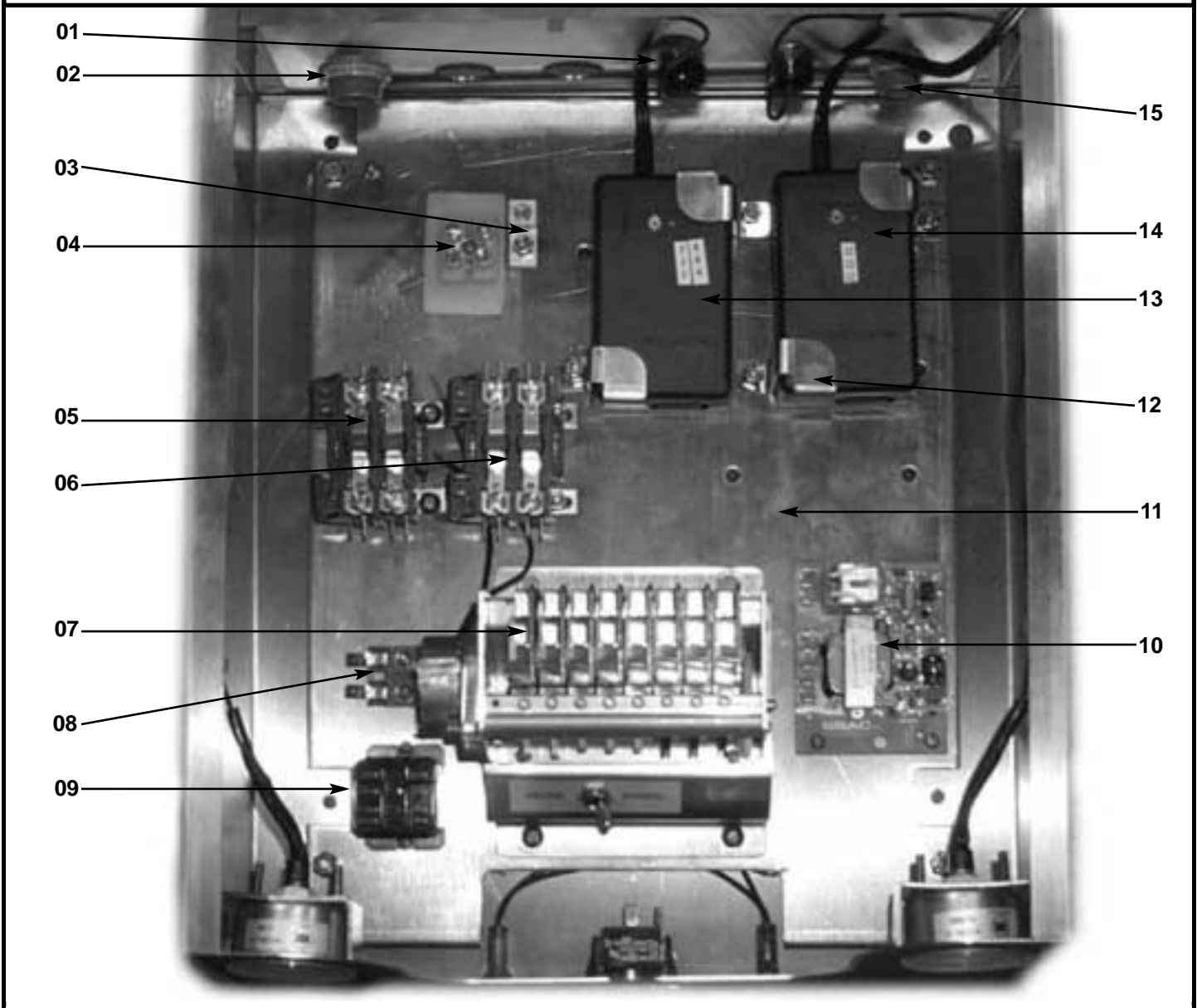
ITEM	QTY	DESCRIPTION	MFG NO.
01	1	Control Box Cover	5700-041-90-72
02	1	Control Box Assembly	Refer To Control Box Page
03	1	Front Door	5700-002-21-15
04	1	Left Door Assembly	5700-002-21-31
05	1	Hood Assembly	5700-002-18-75
06	1	Front Panel	5700-002-19-44
07	1	Left Side Panel	5700-031-89-63
08	1	Incoming Plumbing Assembly (208v)	5700-002-21-09
09	1	Right Door Assembly	5700-002-21-33
10	1	Cantilever Arm Assembly	5700-002-21-34
11	1	Right Side Panel	5700-002-16-32
12	1	Vent Flue Assembly	5700-002-19-45
13	1	Vent Flue Adapter (NOT SHOWN)	5700-002-22-70
14	4	Bullet Feet	5340-108-02-06

CONTROL BOX ASSEMBLY - FRONT VIEW



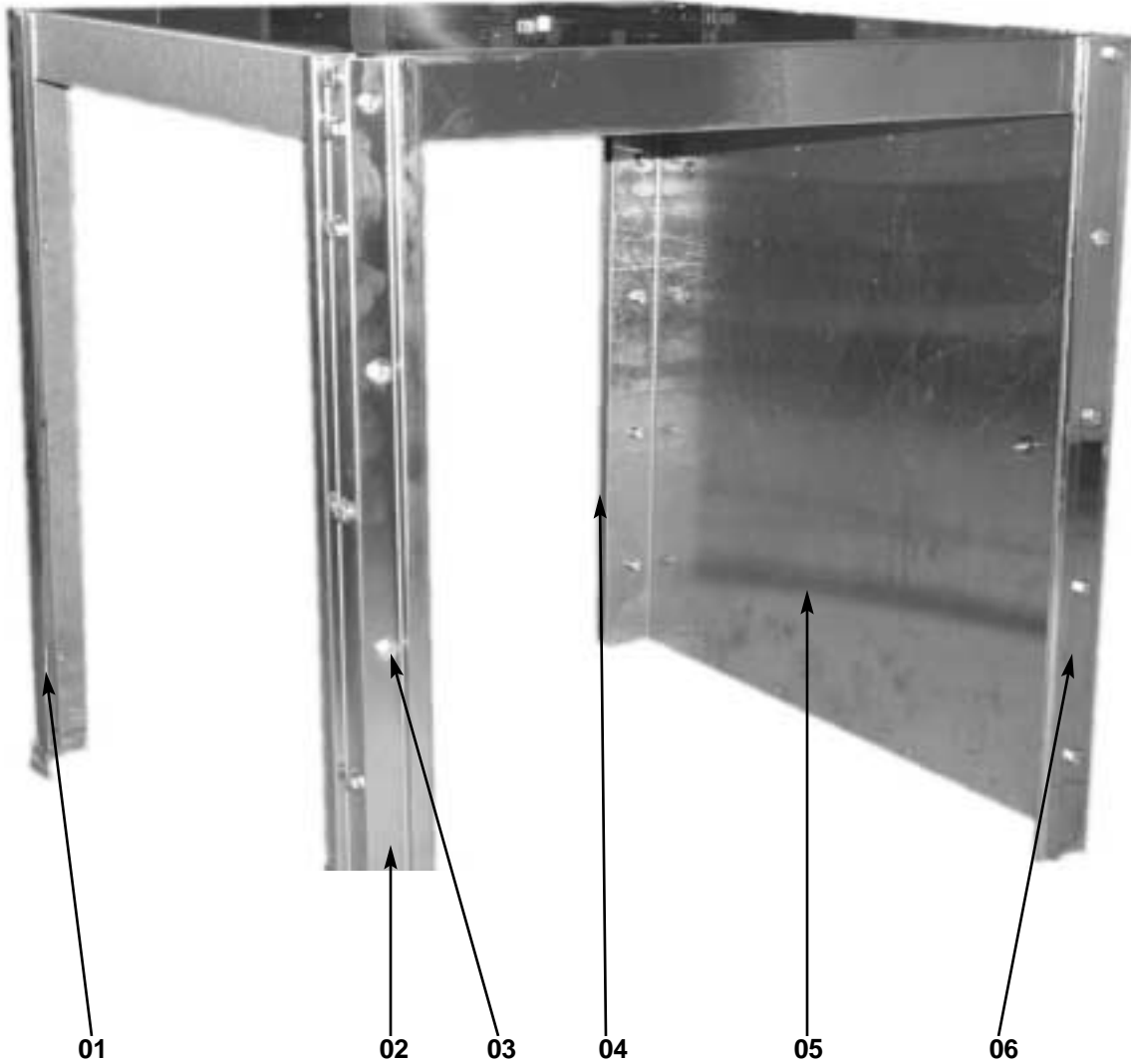
ITEM	QTY	DESCRIPTION	MFG NO.
01	1	Control Box Cover Decal	9905-021-91-15
02	1	Rinse Thermometer, 48" Lead	6685-111-68-48
03	1	Power Light (Red)	5945-504-07-18
04	1	Screw, 10-32 X 3/8" Phillips Truss Head	5305-173-12-00
05	1	Delime (Manual Wash) Switch	5930-301-21-18
06	1	On / Off Power Switch	5930-011-49-55
07	1	Delime/Normal Decal	9905-011-34-96
08	1	Timer, 220v/50, 8 cam	5945-001-99-08
09	1	Cycle Light (Green)	5945-504-08-18
10	1	Timer Mounting Bracket	5700-021-34-54
11	8	Micro Switch	5945-111-68-49
12	1	Wash Thermometer, 96" Lead	6685-111-68-49

CONTROL BOX ASSEMBLY - TOP VIEW



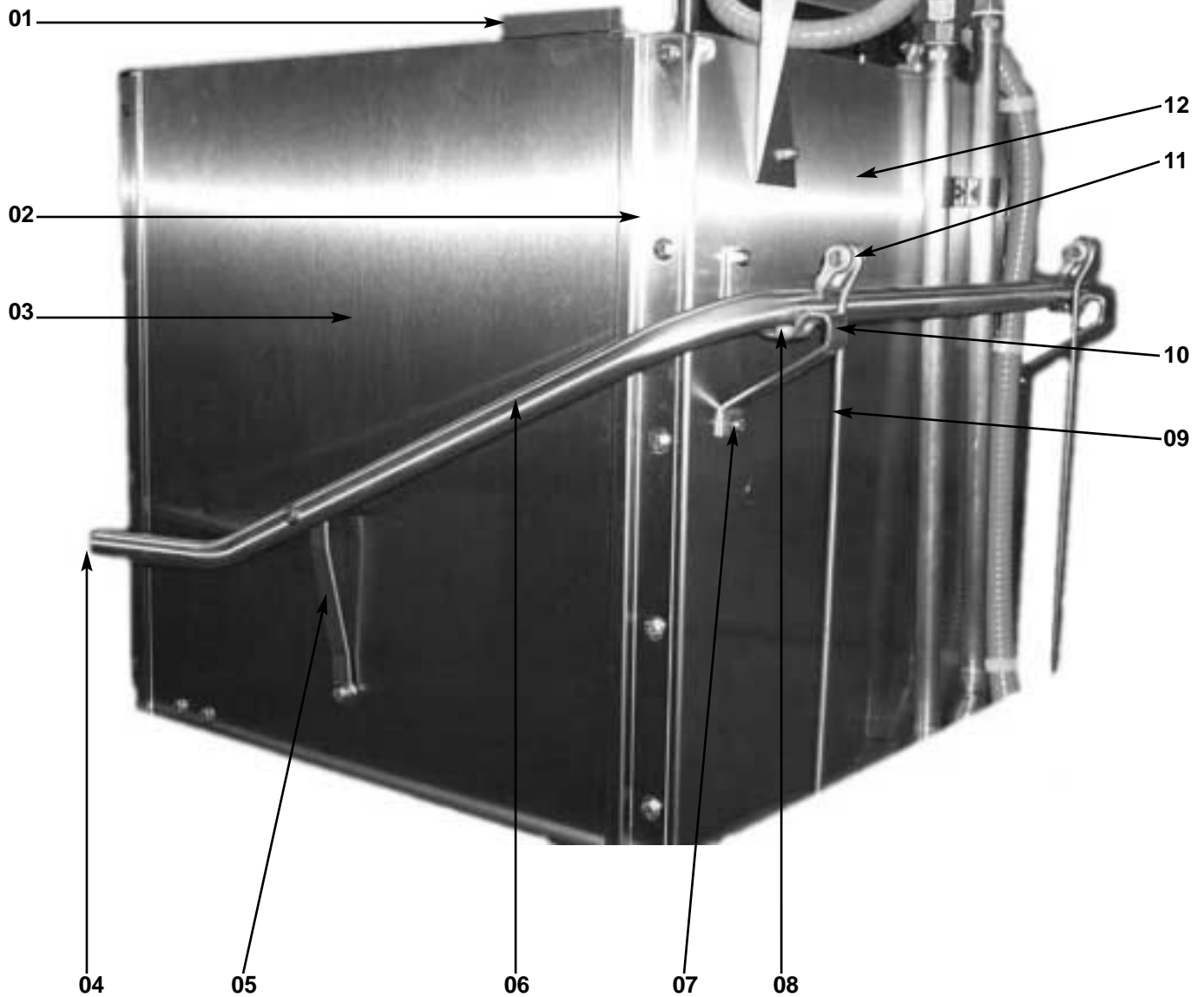
ITEM	QTY	DESCRIPTION	MFG NO.
01	2	Heyco Plug	5975-200-40-00
02	1	Fitting, Co;nduit Non-Metalic, 3/4" x 45	5975-011-47-74
03	1	Ground Lug	5940-200-76-00
04	1	Terminal Block 2 pole	5940-500-09-61
05	1	Contactora, 2 Pole, 220v, 20amp (Wash Motor)	5945-109-03-69
06	1	Contactora, 2 Pole, 220v, 20amp (Wash Temperature)	5945-109-03-69
07	1	Timer, 220v/ 50hz/ 8 Cam	5945-001-99-08
08	1	Fuse Holder	5920-401-03-14
09	1	Relay, Control 240v/ 50-60hz Top Mount	5945-111-47-51
10	1	Liquid Level Control, (220v)	6680-200-08-21
11	1	Inner Control Panel Assembly, TGP 208/50/1	5700-002-21-06
12	4	Transformer Mounting Bracket	5700-002-18-95
13	1	Transformer, 100-240vac to 24vdc	5950-002-19-88
14	1	Transformer, 100-240vac to 12vdc	5950-002-17-87
15	1	Fitting, Conduit Non-Metalic, 1/2" x 90	5975-011-45-14

HOOD ASSEMBLY



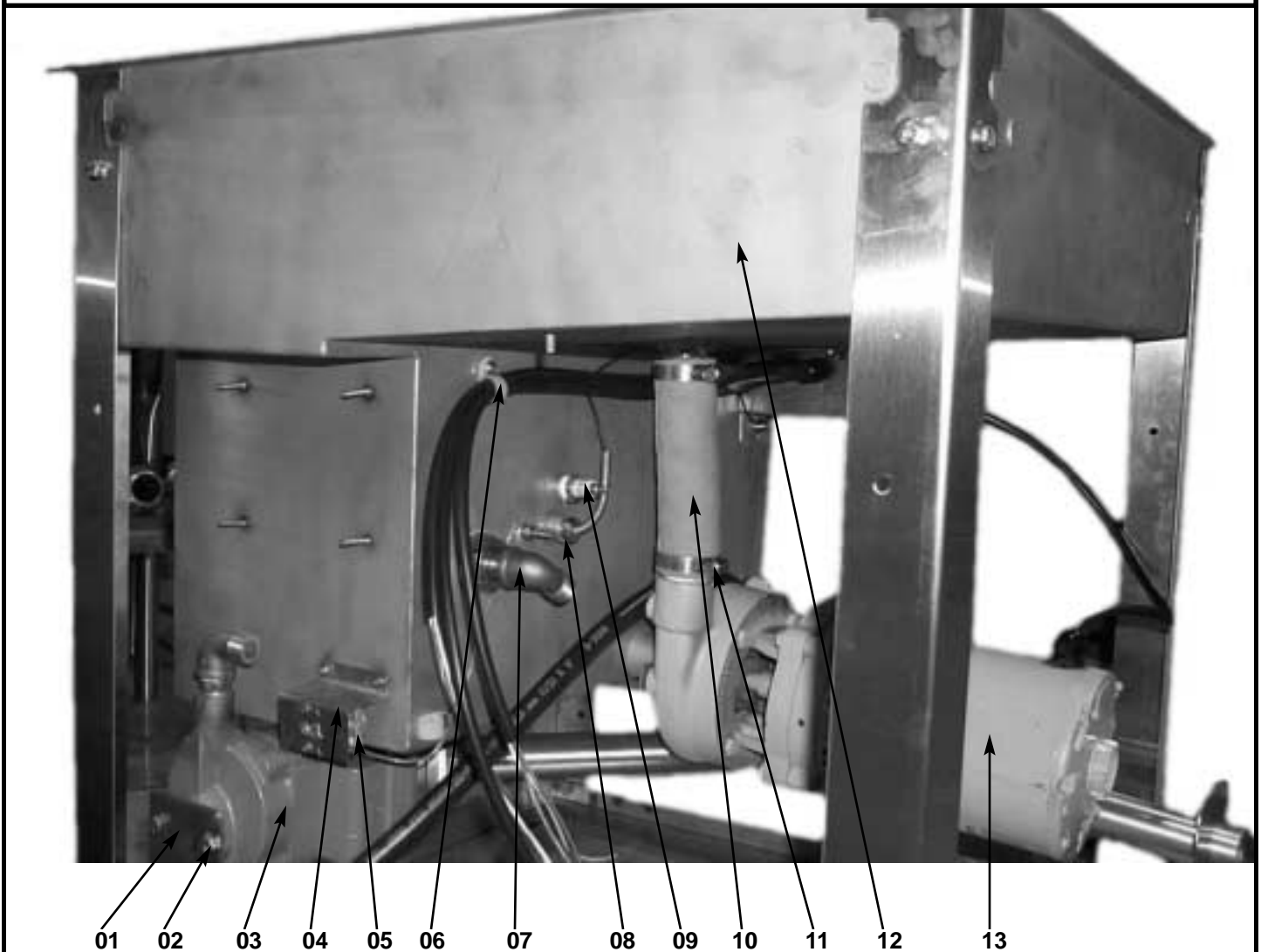
ITEM	QTY	DESCRIPTION	MFG NO.
01	1	Double Door Guide, Left Front	5700-021-33-20
02	1	Double Door Guide, Right Front	5700-021-33-19
03	28	Screw, 1/4"- 20 x 1/2"	5305-274-02-00
03	28	Washer, s/s 1/4" ID	5311-174-01-00
03	28	Locknut, 1/4"- 20 s/s Hex w/Nylon Insert	5310-374-01-00
04	1	Door Guide, Left Rear	5700-021-84-71
05	1	Hood Weldment	5700-002-18-76
06	1	Door Guide, Right Rear	5700-021-84-70

CANTILEVER ARM ASSEMBLY



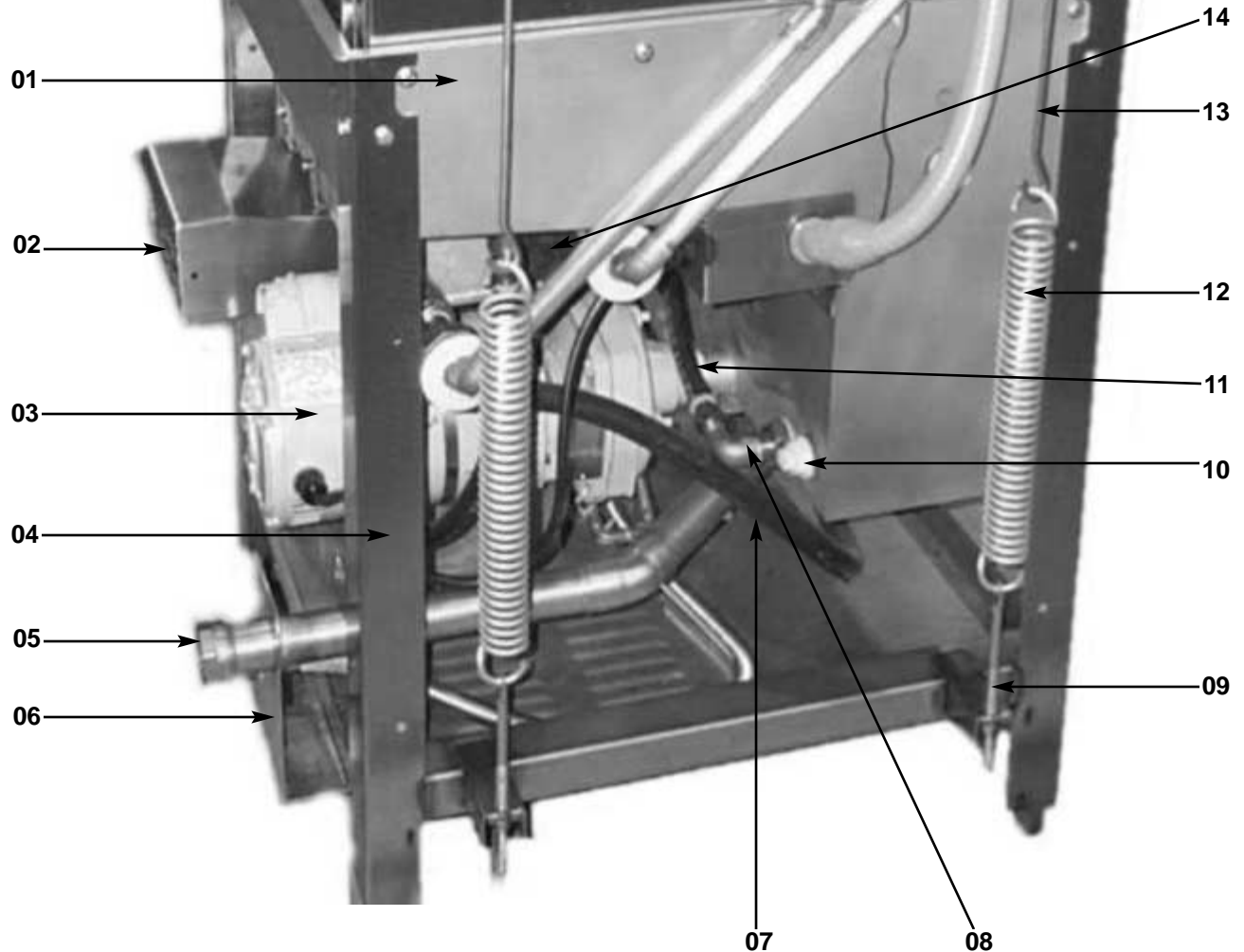
ITEM	QTY	DESCRIPTION	MFG NO.
01	1	Magnet, Reed Switch	5930-111-51-68
02	1	Door Guide, Right Rear	5700-021-84-70
03	1	Door, Right Side Assembly	5700-002-21-33
04	2	Plug, Cantilever	5340-011-35-00
05	2	Cantilever Arm Connector	5700-011-90-99
06	1	Cantilever Arm	5700-031-50-67
07	4	Washer, s/s 1/4" ID	5311-174-01-00
07	4	Locknut, 1/4"- 20 s/s Hex w/Nylon Insert	5310-374-01-00
08	6	Wear Button, 1/2" Dia, UHMW	5700-001-98-69
09	2	Spring Rod	5700-001-28-18
10	2	Cantilever Arm Support Bracket	5700-031-88-00
11	2	Yoke Assembly	5700-000-75-78
12	1	Hood Assembly	5700-041-90-56

TUB ASSEMBLY



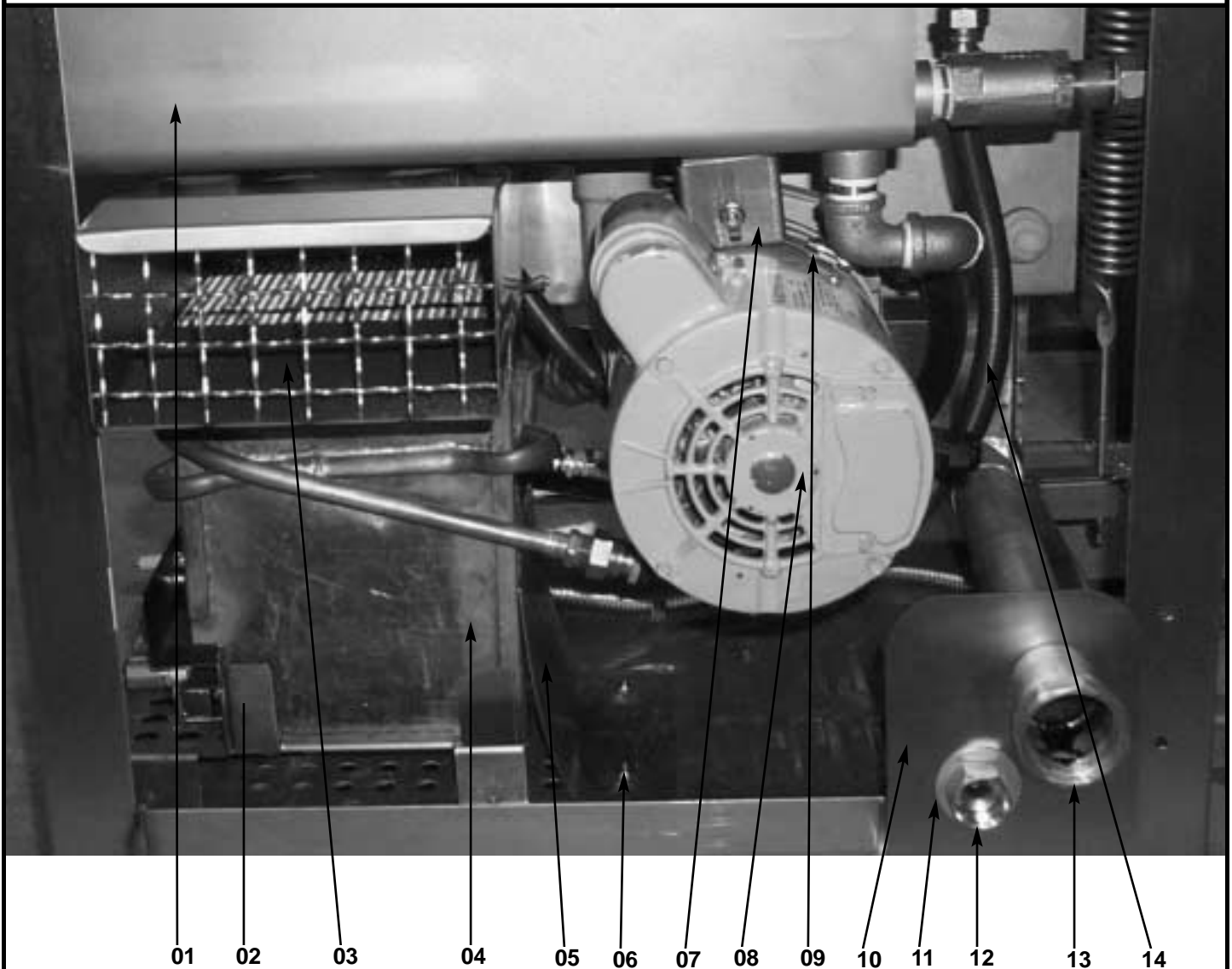
ITEM	QTY	DESCRIPTION	MFG NO.
01	1	Bracket, Recirculating Pump	5700-002-14-85
02	2	Lock Washer, 5/16" s/s Split Ring	5311-275-01-00
02	2	Bolt, Hex Head 5/16"- 18 X 5/8"	5305-275-09-00
03	1	Pump, Recirculating 220v Assembly	5700-002-17-77
04	1	Bracket, Thermostat	5700-011-73-77
05	1	Thermostat, Wash Temperature Over Limit 78 Deg	5930-121-67-72
06	3	Clamp, 5/8" Nylon	4730-011-39-01
07	2	Elbow, 90Deg 1/2" Street Brass	4730-206-08-00
08	1	Thermometer, Wash 96" Lead	6685-111-68-49
09	1	Probe, High Water	6680-200-02-68
10	1	Hose Assembly, Wash Pump Discharge 1 1/4" ID	5700-002-18-85
11	2	Clamp, Reg. Range 1 5/16"- 2 1/4"	4730-719-01-37
12	1	Tub Weldment	5700-002-18-77
13	1	Wash Pump & Motor Assembly, 240v/50hz/1ph	6105-002-19-87

BACK OF TUB, & DRAIN ASSEMBLY



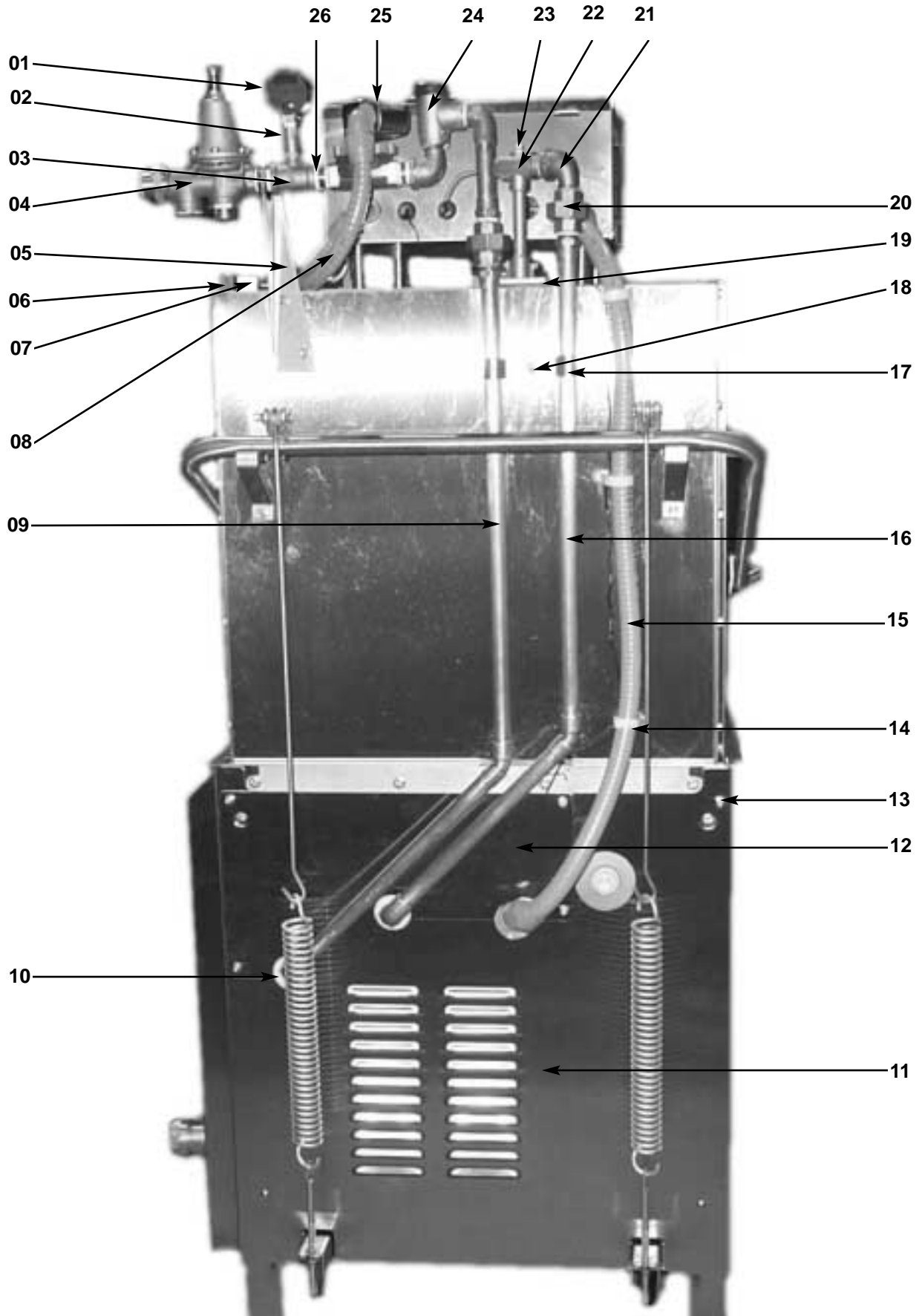
ITEM	QTY	DESCRIPTION	MFG NO.
01	1	Tub Weldment	5700-002-18-77
02	1	Vent Flue Assembly	5700-002-19-45
03	1	Wash Pump & Motor Assembly, 240v/50hz/1ph	6105-002-19-87
04	1	Frame Weldment	5700-002-18-78
05	1	Plumbing, Drain Assembly	5700-002-21-29
06	1	Bracket, Drain Support	5700-002-20-58
07	1	Hose, 3/4" Recirculating Pump Suction	5700-002-17-79
08	2	Elbow, 90 Deg 1/2" Street Brass	4730-206-08-00
09	2	Bolt, Cantilever Hanger Eye 3/8"-16	5306-956-05-00
10	2	Plug, Bulk Head	4730-609-05-00
11	1	Hose, 1/2" Recirculating Pump Discharge	5700-002-17-71
12	2	Spring	5340-109-02-00
13	2	Rod, Spring	5700-001-28-18
14	1	Hose, 1/2" Heat Exchanger Inlet Assembly (not shown)	5700-002-17-73

LOWER ASSEMBLY (RIGHT SIDE)



ITEM	QTY	DESCRIPTION	MFG NO.
01	1	Rinse Tank Assembly	5700-002-17-80
02	1	Saddle, Burner	5700-002-18-74
03	1	Vent Flue Assembly	5700-002-19-45
04	1	Heat Exchanger, Copper	5700-002-20-50
05	1	Air Shield	5700-002-18-27
06	6	Locknut, 10-24 s/s Hex w/Nylon Insert	5310-373-01-00
07	1	Bracket, Pump Support Assembly	5700-002-18-81
08	1	Wash Pump & Motor Assembly, 240v/50hz/1ph	6105-002-19-87
09	1	Clamp, 5 5/8" to 6"	4730-011-34-90
10	1	Bracket, Drain Support	5700-002-20-58
11	2	Washer,	5700-001-17-87
12	1	Hose, Flex Gas s/s Assembly	5700-011-93-95
13	1	Plumbing, Drain Assembly	5700-002-21-29
14	1	Hose, Heat Exchanger Outlet Assembly	5700-002-17-75

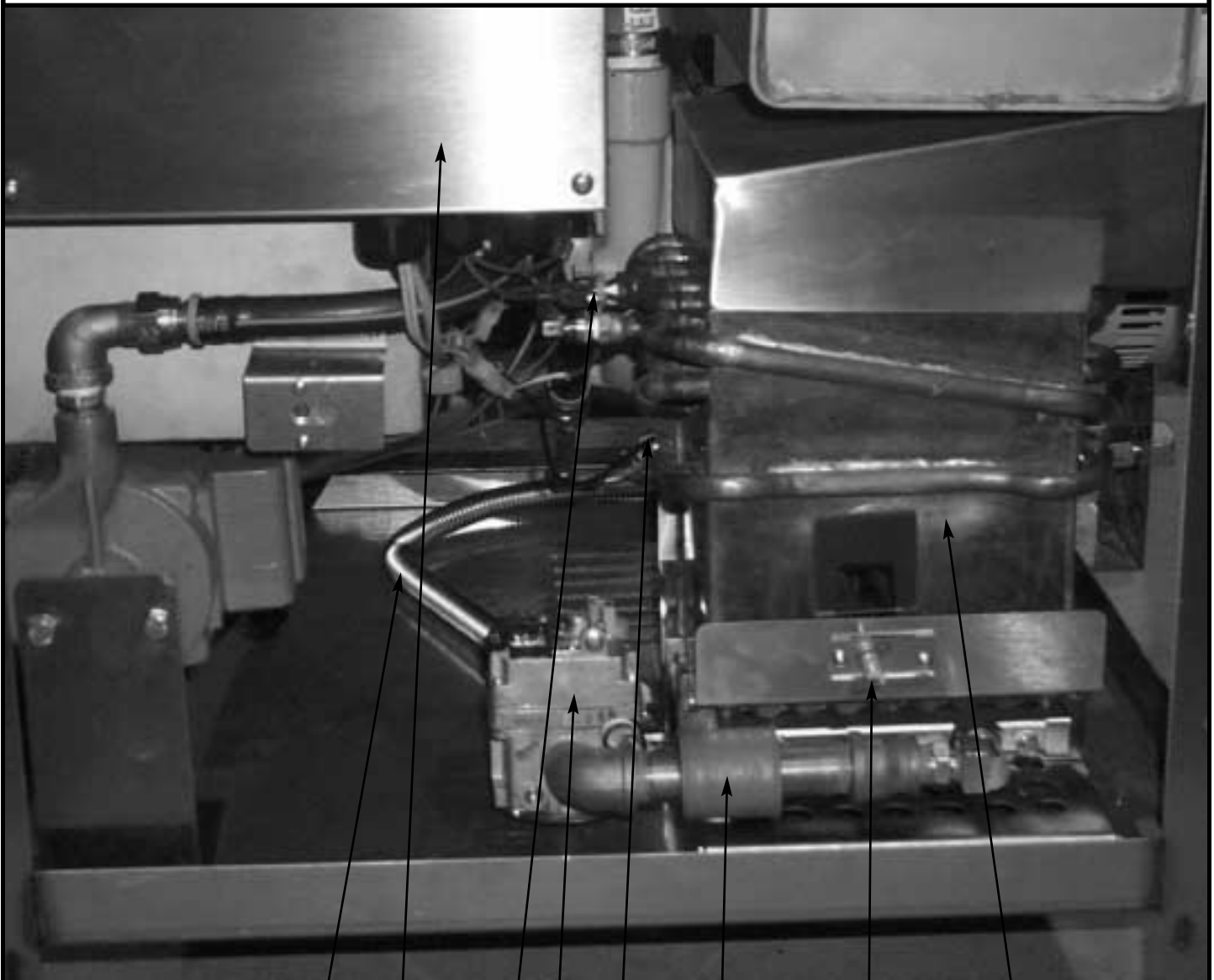
INCOMING PLUMBING ASSEMBLY



INCOMING PLUMBING PARTS LISTS

ITEM	QTY	DESCRIPTION	MFG NO.
01	1	Pressure Guage, 0-100 PSI	6685-111-88-34
02	1	Ball Valve, Test Cock, 1/4" Bronze	4810-011-72-67
03	1	Tee, Brass, 3/4 X 3/4 X 1/4	4730-211-04-00
04	1	Pressure Regulator	6685-011-58-22
05	1	Incoming Plumbing Support Bracket	5700-021-34-02
06	1	Magnet, Reed Switch	5930-111-51-68
07	1	Reed Switch	5930-111-41-70
08	1	Conduit, 1/2" X 14"	5700-011-46-97
09	1	Plumbing Assembly, Inlet to Rinse Tank	5700-002-18-87
10	2	Washer, Teflon	5330-200-11-00
11	1	Panel, Lower Back Cover	5700-002-17-99
12	1	Panel, Upper Back Cover	5700-002-17-98
13	5	Locknut, 10-24 s/s Hex w/Nylon Insert	5310-373-01-00
14	1	Clamp, Nylon 1 1/4"	4730-011-51-16
15	1	Conduit, 3/4" X 37 1/2"	5700-002-19-08
16	1	Plumbing Assembly, Outlet From Rinse Tank	5700-002-18-90
17	1	Clamp, Double Pipe	5700-002-23-89
18	1	Washer, 1/4" ID s/s	5311-174-01-00
18	1	Locknut, 1/4-20 s/s Hex w/Nylon Insert	5310-374-01-00
19	2	Gasket, Vellumoid	5330-111-42-81
20	4	Union, Brass, 3/4"	4730-212-05-00
21	2	Elbow, 3/4" 90 Deg Street Brass	4730-206-04-34
22	1	Rinse Injector SDS Weldment	5700-021-47-65
23	3	Plug, 1/8" NPT Brass	4730-209-07-37
24	1	Vacuum Breaker, 3/4"	4820-300-08-00
25	1	Solenoid Valve, 3/4" 240v	4810-100-03-18
26	3	Close Nipple, 3/4" Brass	4730-207-34-00

GAS PACK ASSEMBLY



01 02 03 04 05 06 07 08

ITEM	QTY	DESCRIPTION	MFG NO.
	1	Gas Pack (TOWNGAS)	5700-002-19-83
01	1	Hose, Flex Gas s/s Assembly	5700-011-93-95
02a	1	Cover, Electronics Drawer w/Sight Glass	5700-002-18-62
02b	1	Electronics Control Drawer Assembly	5700-002-21-10
03	1	T-Mid Thermister Assembly	5700-002-12-22
04	1	Valve, Solenoid,Combination Cut Off	4810-002-20-11
05	1	T-In Thermister Assembly	5700-002-12-23
06	1	Valve, Modulating 24v	4810-002-20-12
07	1	Spark Probe Igniter	6680-002-12-24
08	1	Heat Exchanger (copper)	5700-002-20-50

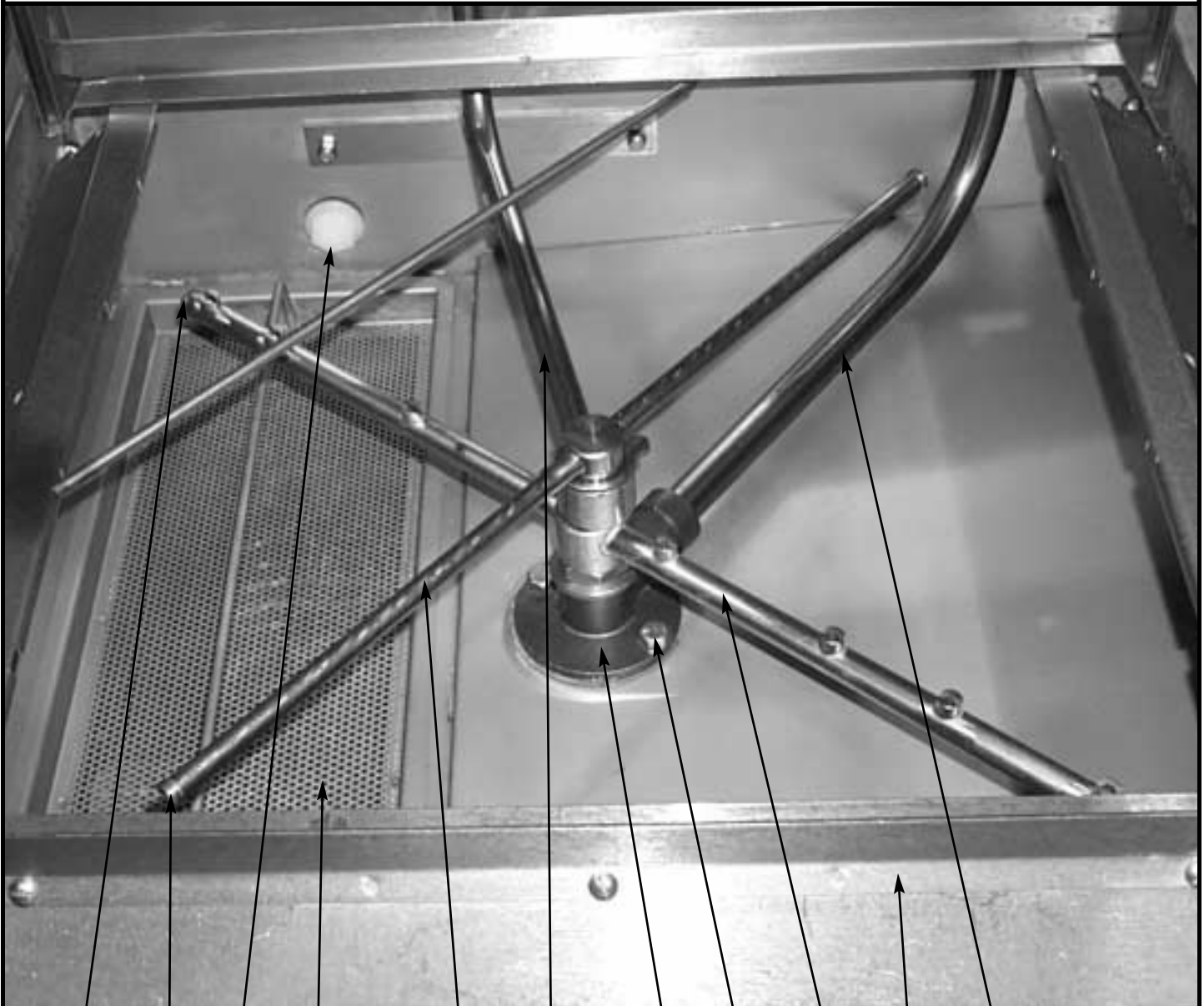
UPPER WASH, & RINSE ARM ASSEMBLY



01 02 03 04 05 06 07 08 09 10 11 12

ITEM	QTY	DESCRIPTION	MFG NO.
01	2	Wash Arm End Plug	5700-011-35-92
02	1	Rinse Manifold Assembly	5700-021-47-61
03	1	Wash Manifold Tube	5700-131-15-07
04	1	Wash Arm	5700-021-35-93
05	2	Nut, 3/8-16 Hex	5310-276-01-00
06	2	Bolt, 3/8-16 X 1-1/4" Long Hex	5305-276-10-00
07	1	Upper Wash Casting	5700-031-34-82
08	1	Rinse Arm	5700-031-50-63
09	8	Locknut, 1/4"- 20 s/s Hex w/Nylon Insert	5310-374-01-00
10	2	Rinse Arm End Plug	4730-609-04-00
11	1	Hood Assembly	5700-041-90-56
12	2	Bracket, Door Connecting	5700-021-33-39

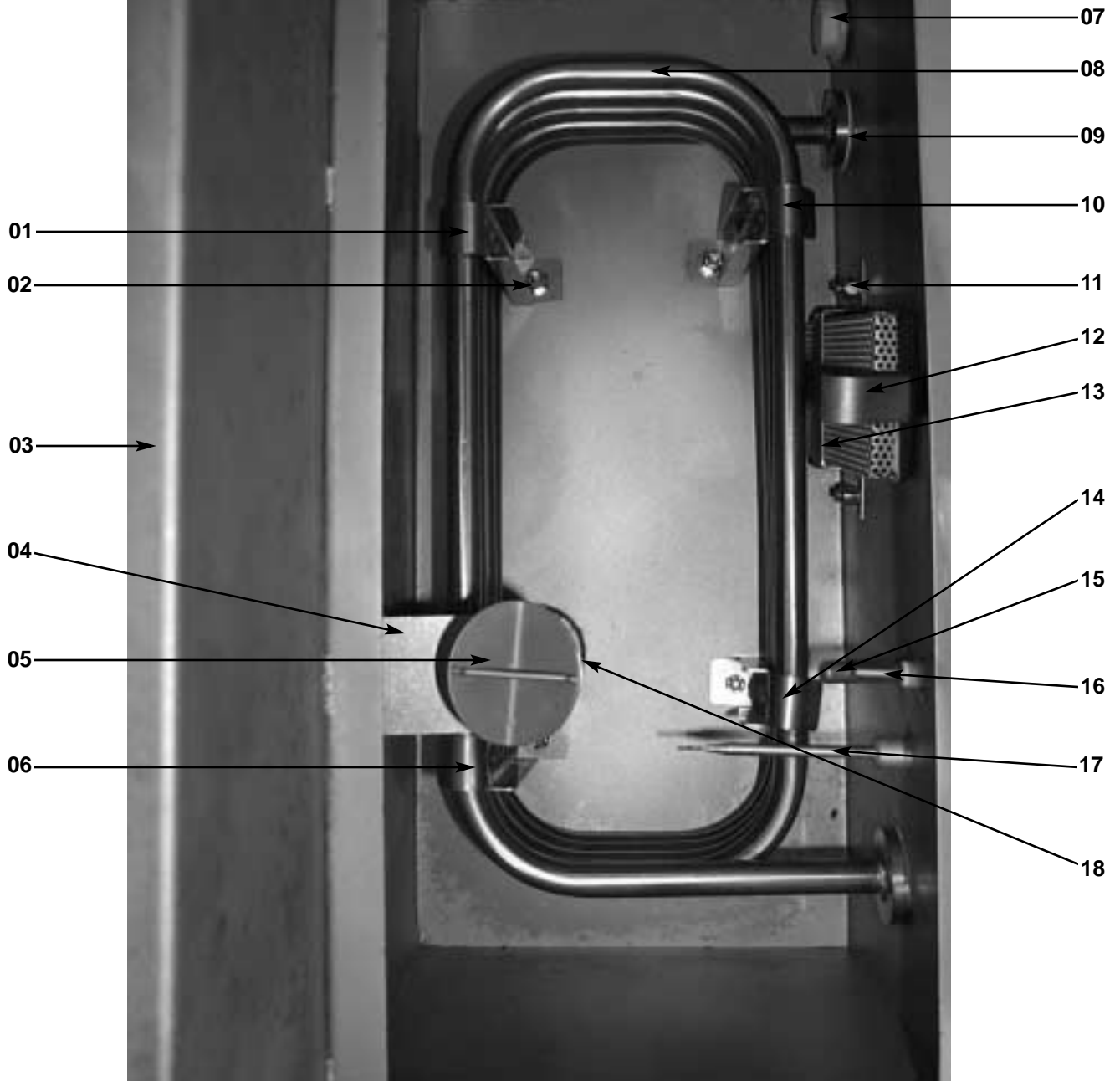
LOWER WASH, & RINSE ARM ASSEMBLY



01 02 03 04 05 06 07 08 09 10 11

ITEM	QTY	DESCRIPTION	MFG NO.
01	2	Wash Arm End Plug	5700-011-35-92
02	2	Rinse Arm End Plug	4730-609-04-00
03	1	Bulk Head Plug	4730-609-05-00
04	1	Strainer Weld Assembly	5700-031-50-07
05	1	Rinse Arm	5700-031-50-63
06	1	Rinse Manifold Assembly	5700-021-47-61
07	1	Lower Wash Casting	5700-031-46-01
08	2	Bolt, 3/8" X 1 1/4" Long	5305-276-10-00
09	1	Wash Arm	5700-021-35-93
10	1	Rack Guide Weldment	5700-002-01-01
11	1	Lower Wash Manifold	5700-002-05-18

STEAM COIL ASSEMBLY

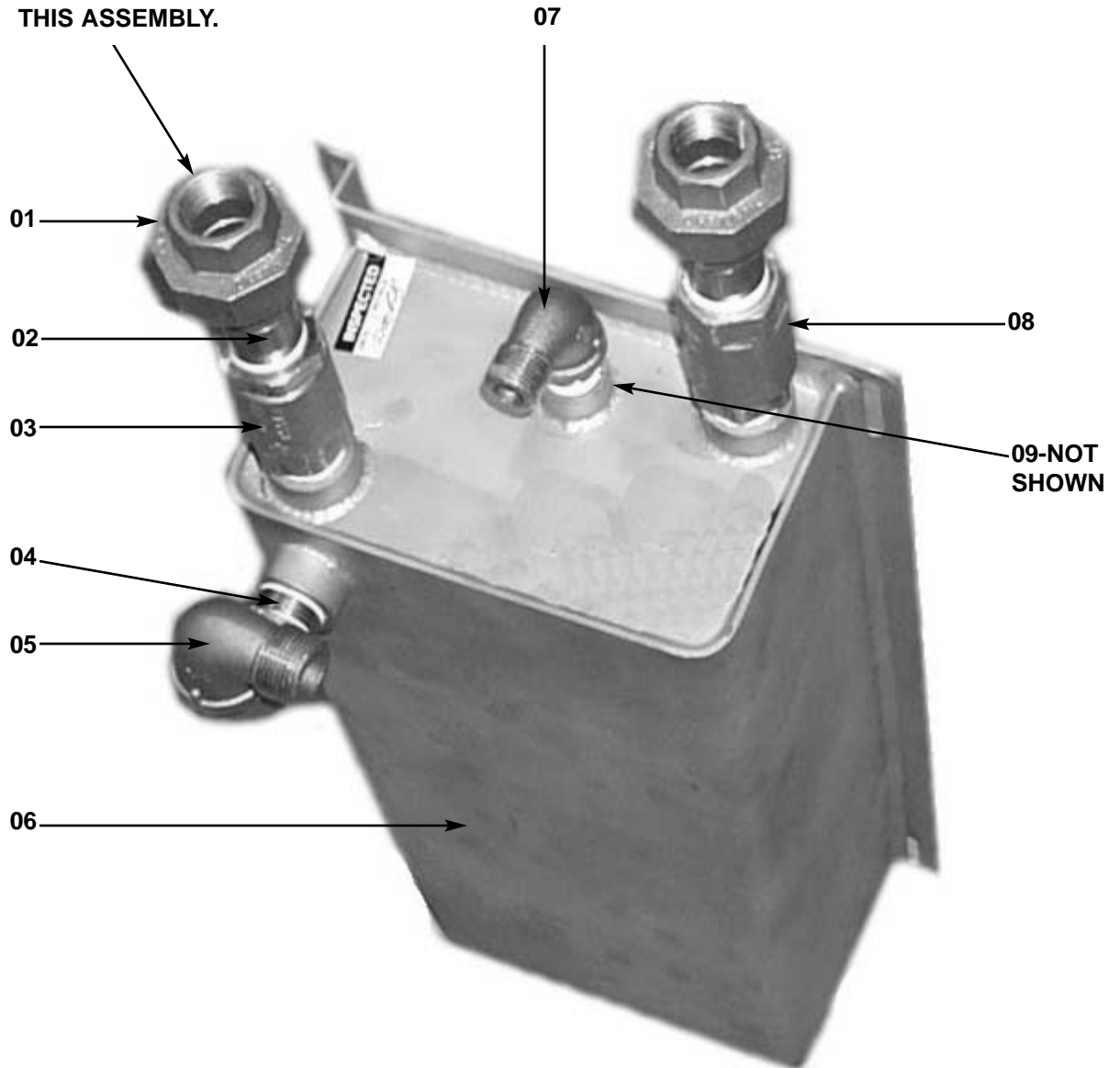


STEAM COIL ASSEMBLY (PARTS LISTS)

ITEM	QTY	DESCRIPTION	MFG NO.
01	1	Stand-D, Steam Coil Support	5700-002-08-53
02	4	Locknut, 1/4-20 s/s Hex w/Nylon Insert	5310-374-01-00
02	4	Washer, s/s 1/4 I.D.	5311-174-01-00
03	1	Tub Weldment	5700-041-90-30
04	1	Overflow Support Bracket	5700-001-27-55
05	1	Wash, Overflow Weldment	5700-001-25-69
06	1	Stand-C, Steam Coil Support	5700-002-08-52
07	1	Bulk Head Plug	4730-609-05-00
08	1	Steam Coil Weldment	5700-021-41-38
09	4	Gasket, Steam Coil	5700-001-17-86
10	1	Stand-A, Steam Coil Support	5700-002-08-50
11	2	Locknut, 1/4-20 s/s Hex w/Nylon Insert	5310-374-01-00
12	1	Suction Strainer Weldment	5700-001-22-23
13	1	Bracket, Suction Strainer	5700-001-22-24
14	1	Stand-B, Steam Coil Support	5700-002-08-51
15	1	Wash Thermometer 96" Lead	5700-111-68-49
16	1	Thermostat, Wash Regulating 78 Deg	5930-121-67-72
17	1	Probe, High Water	6680-200-02-68
18	1	O- Ring, Vitan #03-218	5330-400-05-00

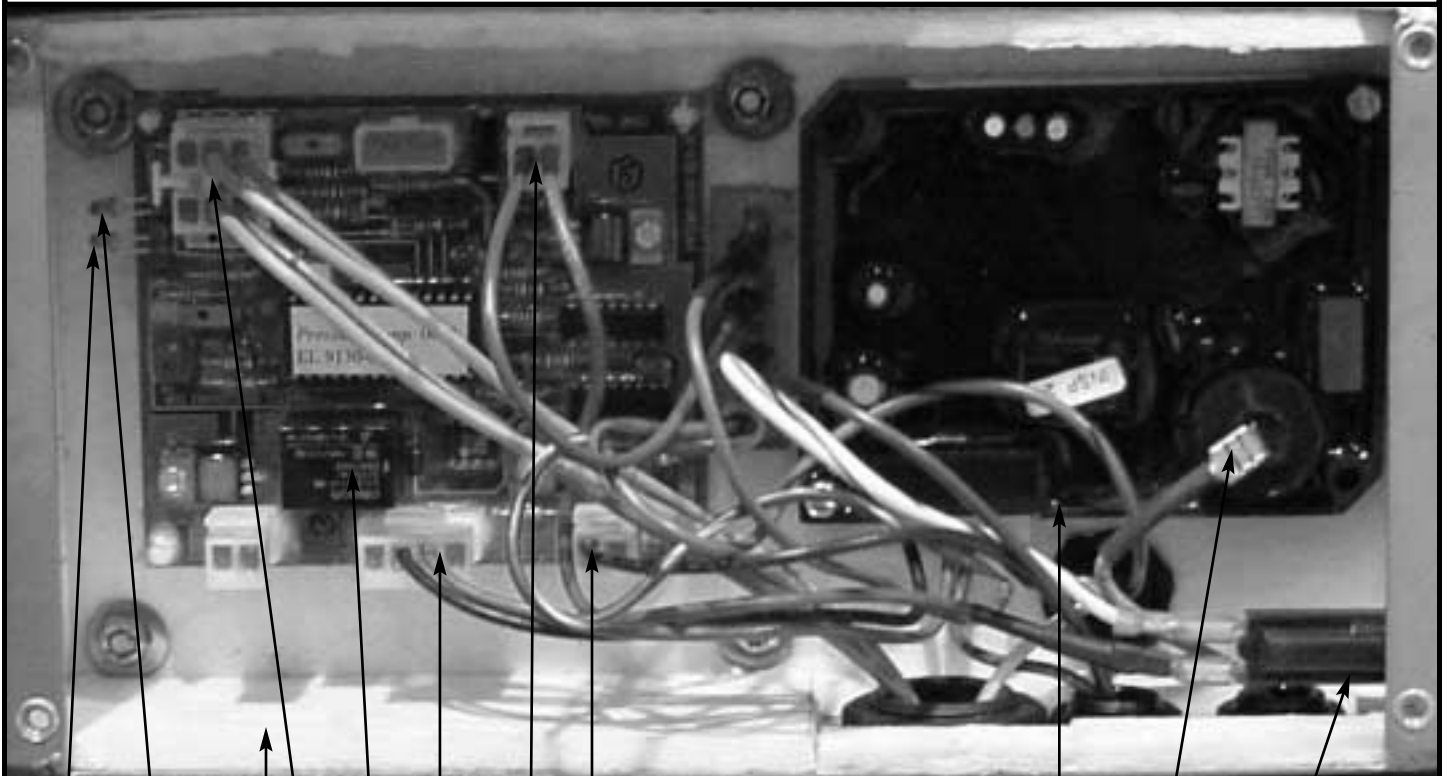
RINSE TANK ASSEMBLY

NOTE: THESE UNIONS ARE NOT INCLUDED WITH THIS ASSEMBLY.



ITEM	QTY	DESCRIPTION	MFG NO.
	1	Rinse Tank Assembly	5700-002-17-80
01	2	Union, Brass (Comes With Incoming Plumbing Assy)	4730-212-05-00
02	2	Nipple, 3/4" X 2"	4730-207-46-00
03	1	Valve, 3/4" NPT Female Check High	4820-002-01-76
04	3	Nipple, 3/4" NPT X 1 3/8" Close Brass	4730-207-34-00
05	2	Elbow, 3/4" Street Brass	4730-206-04-34
06	1	Rinse Tank Weldment	5700-002-17-81
07	1	Elbow, 90 Deg 1/2" Street Brass	4730-206-08-00
08	1	Valve, 3/4" NPT Female Check	4820-011-94-20
09	1	Circulating Return Tube (NOT SHOWN)	5700-021-92-39

ELECTRONIC CONTROL DRAWER COMPONENTS



RED LED
GREEN LED

1 2 3 4 5 6

7 8 9

ITEM	QTY	DESCRIPTION	MFG NO.
01	1	Electronic Control Drawer Assembly	5700-002-21-10
02	1	Wiring Harness-Thermistor Cable	5700-002-12-34
03	1	Electronic Control Board (ECB)	6680-002-12-26
04	1	Wiring Harness-DSI Cable	5700-002-12-36
05	1	Wiring Harness-Power Supply Cable	5700-002-12-35
06	1	Wiring Harness-Modulating Valve (TGP)	5700-002-37-03
07	1	Direct Spark Ignition Board (DSI)	6680-002-12-25
08	1	Ignition Cable	5700-002-12-37
09	1	Circuit Breaker 3 amp	5925-022-36-94

METRIC CONVERSIONS

LENGTH

<u>IMPERIAL</u>	<u>METRIC</u>
1 INCH	2.54 cm
1 FOOT (12 INCHES)	0.3048 m
1 YARD (3 FEET)	0.9144 m
1 MILE (1760 YARDS)	1.6093 km

AREA

<u>IMPERIAL</u>	<u>METRIC</u>
1 SQUARE INCH (in ²)	6.4516 cm ²
1 SQUARE FOOT (ft ²)	0.0929 m ²
1 SQUARE YARD (yd ²)	0.8361 m ²
1 SQUARE MILE	2.59 km ²

TEMPERATURE CONVERSION

$$^{\circ}\text{F} = ^{\circ}\text{C} \times 1.8 + 32$$

$$\text{Example: } ^{\circ}\text{F} = 32^{\circ}\text{C} \times 1.8 + 32 = 89.6^{\circ}\text{F}$$

$$^{\circ}\text{C} = (^{\circ}\text{F} - 32)/1.8$$

$$\text{Example: } ^{\circ}\text{C} = (100^{\circ}\text{F} - 32)/1.8 = 37.8^{\circ}\text{C}$$

FLUID CAPACITY

<u>IMPERIAL</u>	<u>METRIC</u>
1 GALLON (US)	3.785412 L
1 QUART (US)	946.3539 mL
1 PINT (US)	473.1765 mL
1 FLUID OUNCE (US)	29.574 mL

VOLUME

<u>IMPERIAL</u>	<u>METRIC</u>
1 CUBIC INCH (in ³)	16.3871 cm ³
1 CUBIC FOOT (ft ³)	0.02831 m ³
1 CUBIC YARD (yd ³)	0.7645549 m ³

SPEED

<u>IMPERIAL</u>	<u>METRIC</u>
1 FOOT/MINUTE	0.3048 m/m
1 FOOT/SECOND	0.3048 m/s
1 MILE/HOUR	1.609344 km/h

FLOW

<u>IMPERIAL</u>	<u>METRIC</u>
1 GALLON/MINUTE	0.0038 m ³ /min
1 GALLON/HOUR	1.0515 mL/s

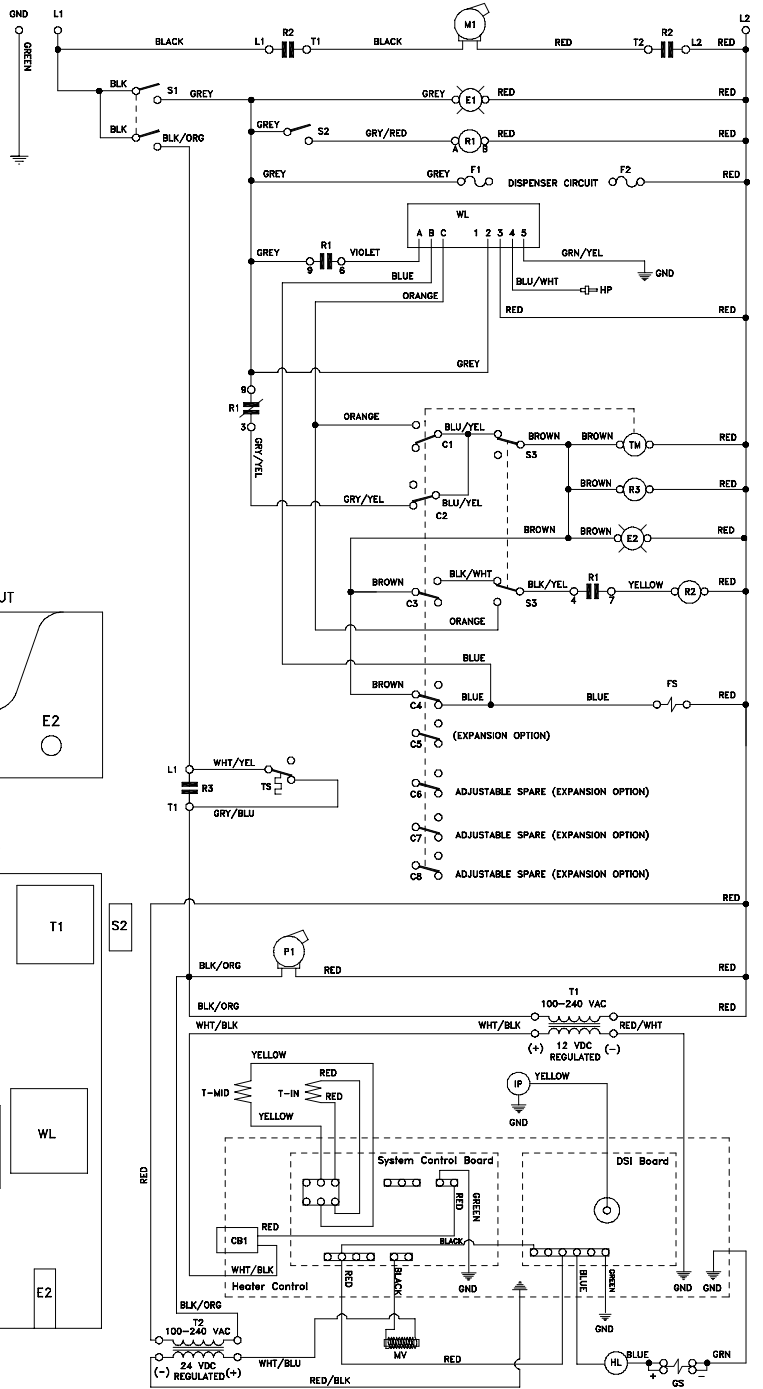
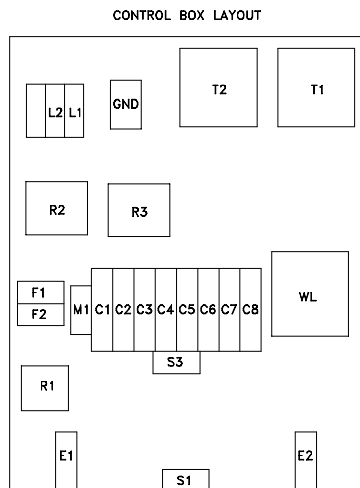
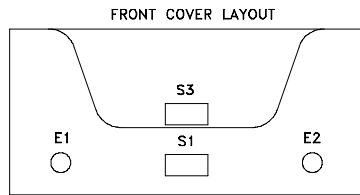
UNITS OF MEASURE

	<u>Length</u>	<u>Weight</u>	<u>Area</u>	<u>Volume</u>	<u>Conveyor Speed</u>
(United States)	In.	lb.	in ²	in ³	ft/min
(Metric)	cm	kg	cm ²	cm ³	m/min

Tempstar TGP ELECTRICAL DIAGRAM 208/240 VOLT - 50 HERTZ - 1 PHASE

LEGEND

- C1 Cycle Switch
- C2 Auto Start Reset Switch
- C3 Wash Cycle Switch
- C4 Rinse/Fill Switch
- C5 Expansion Option Switch
- C6 Expansion Option Switch
- C7 Expansion Option Switch
- C8 Expansion Option Switch
- CB1 Heat Controller Circuit Breaker
- E1 Power Light
- E2 Cycle Light
- F1 Dispenser fuse 1
- F2 Dispenser Fuse 2
- FS Fill Solenoid
- GND Chassis Ground
- GS Gas Solenoid
- HL High Limit
- HP High Level Probe
- IP Ignitor Plug
- M1 Wash Pump Motor
- MV Modulating Valve
- P1 Circulator Pump
- R1 Control Relay
- R2 Wash Motor Contactor
- R3 Wash Temperature Relay
- S1 Power Switch
- S2 Door Switch
- S3 Normal/Delime Switch
- T1 Heat Circuit Power Supply
- T2 Modulating Valve Power Supply
- TS WashThermostat Switch
- TM Timer Motor
- T-MID Thermister Mid
- T-IN Thermister In
- WL Water Level Control



CONDENSED	0	30	60	90	120	150	180	210	240	270	300	330	360	390	420	450	480	510	540	570	600
CYCLE/RESET MICRO	C1	NC	NC	NC	NC	NC	NC	NC	NC	NC	NC	NC	NC	NC	NC	NC	NC	NC	NC	NC	NC
AUTOSTART RESET MICRO	C2	NC	NC	NC	NC	NC	NC	NC	NC	NC	NC	NC	NC	NC	NC	NC	NC	NC	NC	NC	NC
WASH CYCLE MICRO	C3	NC	NC	NC	NC	NC	NC	NC	NC	NC	NC	NC	NC	NC	NC	NC	NC	NC	NC	NC	NC
RINSE/FILL MICRO	C4	NC	NC	NC	NC	NC	NC	NC	NC	NC	NC	NC	NC	NC	NC	NC	NC	NC	NC	NC	NC
NOT USED <C5>	C5	NC	NC	NC	NC	NC	NC	NC	NC	NC	NC	NC	NC	NC	NC	NC	NC	NC	NC	NC	NC
EXPANSION OPTION MICRO	C6	NC	NC	NC	NC	NC	NC	NC	NC	NC	NC	NC	NC	NC	NC	NC	NC	NC	NC	NC	NC
EXPANSION OPTION MICRO	C7	NC	NC	NC	NC	NC	NC	NC	NC	NC	NC	NC	NC	NC	NC	NC	NC	NC	NC	NC	NC
EXPANSION OPTION MICRO	C8	NC	NC	NC	NC	NC	NC	NC	NC	NC	NC	NC	NC	NC	NC	NC	NC	NC	NC	NC	NC

Free Manuals Download Website

<http://myh66.com>

<http://usermanuals.us>

<http://www.somanuals.com>

<http://www.4manuals.cc>

<http://www.manual-lib.com>

<http://www.404manual.com>

<http://www.luxmanual.com>

<http://aubethermostatmanual.com>

Golf course search by state

<http://golfingnear.com>

Email search by domain

<http://emailbydomain.com>

Auto manuals search

<http://auto.somanuals.com>

TV manuals search

<http://tv.somanuals.com>