

MSS530 and MSS630 Loudspeaker Systems



MSS530
MSS630

McIntosh

Thank You

Your decision to own this McIntosh MSS530 or MSS630 Loudspeaker System ranks you at the very top among discriminating music listeners. You now have "The Best." The McIntosh dedication to "Quality," is assurance that you will receive many years of musical enjoyment from this unit.

Please take a short time to read the information in this manual. We want you to be as familiar as possible with all the features and functions of your new McIntosh.

Please Take A Moment

The serial number, purchase date and McIntosh Dealer name are important to you for possible insurance claim or future service. The spaces below have been provided for you to record that information:

Serial Number: _____

Purchase Date: _____

Dealer Name: _____

Technical Assistance

If at any time you have questions about your McIntosh product, contact your McIntosh Dealer who is familiar with your McIntosh equipment and any other brands that may be part of your system. If you or your Dealer wish additional help concerning a suspected problem, you can receive technical assistance for all McIntosh products at:

McIntosh Laboratory, Inc.
2 Chambers Street
Binghamton, New York 13903
Phone: 607-723-3512
Fax: 607-723-3636

Customer Service

If it is determined that your McIntosh product is in need of repair, you can return it to your Dealer. You can also return it to the McIntosh Laboratory Service Department. For assistance on factory repair return procedure, contact the McIntosh Service Department at:

McIntosh Laboratory, Inc.
2 Chambers Street
Binghamton, New York 13903
Phone: 607-723-3515
Fax: 607-723-1917

Table of Contents

Thank You	2
Please Take a Moment	2
Technical Assistance	2
Customer Service	2
Table of Contents	2
Safety Instructions	3
Introduction	4
Performance Features	4
Overall Dimensions	4
Installation	6
How to Connect	8
Specifications	10
Packing Instructions	11

General Notes

- 1. A McIntosh MSS530 Loudspeaker System consists of a pair of MS530 Woofer/Midranges, a pair of MS20 Tweeters and a pair of MN530 Crossover Networks. The McIntosh MSS630 Loudspeaker System consists of a pair of MS630 Woofer/Midranges, a pair of MS20 Tweeters and a pair of MN630 Crossover Networks.*
- 2. Do not exceed the power handling capacity of the MSS530 or MSS630 Loudspeaker System.*
- 3. For additional connection information, refer to the owner's manual(s) for any component(s) connected to the MSS530 or MSS630 Loudspeaker Drivers and Crossover Networks.*
- 4. The Connection Illustrations in this Owner's Manual are only one example of the many different possible combinations. It is recommended that a qualified professional assist you in the choice and installation of a McIntosh Sound System for your vehicle.*
- 5. The MSS530 and MSS630 Loudspeaker Systems are supplied with Mounting Hardware. The Hardware is secured to the inside bottom of the Shipping Carton, refer to the Packing Illustration on page 11.*

IMPORTANT SAFETY INSTRUCTIONS!

PLEASE READ THEM BEFORE OPERATING THIS EQUIPMENT.

General:

1. Read all the safety and operating instructions, contained in this owner's manual, before operating this equipment.
2. Retain this owner's manual for future reference about safety and operating instructions.
3. Adhere to all warnings and operating instructions.
4. Follow all operating and use instructions.
5. **Warning: To reduce risk of fire or electrical shock, do not expose this equipment to rain or moisture. This unit is capable of producing high sound pressure levels. Continued exposure to high sound pressure levels can cause permanent hearing impairment or loss. User caution is advised and ear protection is recommended when playing at high volumes.**

Installation:

6. Do not attempt to install the unit yourself. Please have an authorized dealer install the unit for you.
7. Locate the equipment away from heat sources such as heater ducts.
8. Mount the equipment only as described in this owner's manual.

Connection:

9. Connect this equipment only to the type of power amplifier as described in this owner's manual.
10. Route cords so that they are not likely to be pinched by items placed upon or against them, paying particular attention to the point where they exit from the instrument.

Care of Equipment:

11. Clean the instrument by dusting with a dry cloth.
12. Do not permit objects of any kind to be pushed into and/or fall into the equipment through enclosure openings. Never spill liquids into the equipment through enclosure openings.

Repair of Equipment:

13. Refer servicing to a qualified service personnel under the following conditions:
 - A. The cords or the connectors have been damaged.
 - B. Objects have fallen onto, or liquid has been spilled into the equipment.
 - C. The equipment has been exposed to rain or water.
 - D. The equipment does not operate normally by following the operating instructions contained within this owner's manual.
 - E. The equipment has been dropped or damaged in any way.
 - F. The equipment exhibits a distinct change in performance - this indicates a need for service.
14. When replacement parts are required, be sure the service technician has used replacement parts specified by McIntosh or have the same characteristics as the original part. Unauthorized substitutions may result in fire, electric shock, or other hazards.
15. Upon completion of any service or repairs to this product, ask the service technician to perform safety checks to determine that the product is in proper operating condition.

Introduction

The McIntosh Woofer/Midrange and Tweeter Drivers offer extremely smooth frequency response, low distortion, high sensitivity and high power handling capability. When these Drivers are combined with other McIntosh Vehicle Components, you will enjoy sonically accurate music reproduction in your vehicle which meets McIntosh traditional standards of excellence.

Performance Features

● Patented Technology

The widely acclaimed McIntosh LD/HP® (Low Distortion/High Performance) Magnetic Circuit Design¹ dramatically reduces harmonic distortion.

● Special Woofer/Midrange Driver Design

The Woofer/Midrange Driver utilizes injection molded Black Polypropylene Cones and NBR Rubber Surrounds to provide stable performance in the demanding vehicle environment. Its Die Cast Aluminum Frame ensures excellent rigidity, dimensional integrity and lasting value.

● Special Tweeter Driver Design

The Tweeter Driver utilizes a black, Soft Textile Dome for smooth response and greater sensitivity. It also incorporates a Neodymium Magnet which has the highest flux energy that is currently available. The Tweeter Design utilizes both Tinsel Voice Coil Leads and Magnetic Fluid for improved repetitive high peak power handling capability. Pre-attached leads simplify connection to the Crossover Network.

● Low Distortion Crossover

The Crossover utilizes capacitors with low ESR, coils with low DCR and a 2nd Order Crossover Circuit Design for smooth frequency response. The Crossover allows for three different high frequency response curves to compensate for various automotive environments. It incorporates a self resetting Poly-Switch to provide automatic overload protection to the Loudspeaker System. The Crossover Enclosures are made from a high temperature ABS material capable of withstanding the demanding temperature variations of a vehicle environment.

¹Patent Number 5,151,943

Top View of the MN530 and MN630 Crossover Networks

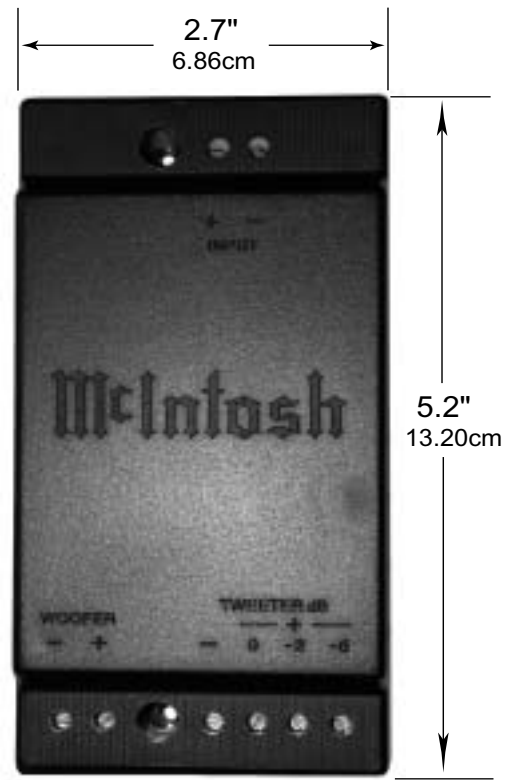

Side View of the MN530 and MN630 Crossover Networks

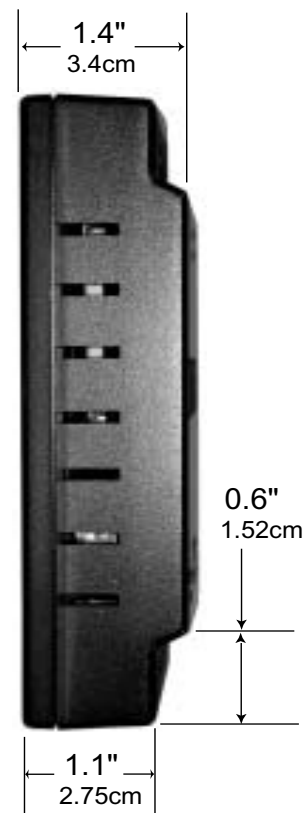

Front View of the MS20 Tweeter Driver

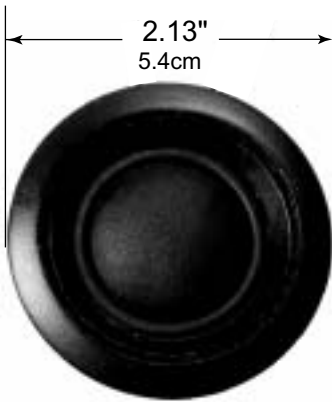

Side View of the MS20 Tweeter Driver



Rear View of the MS20 Tweeter Driver



Front View of the MS530 Woofer/Midrange Driver

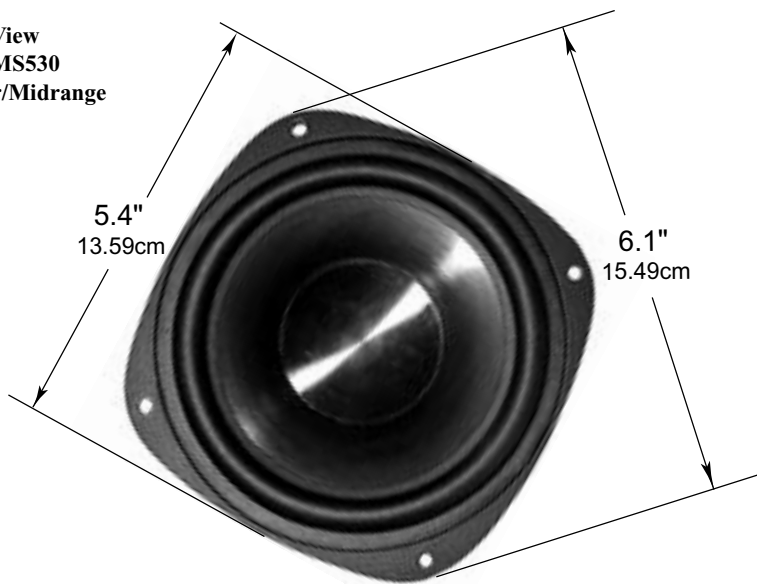

Side View of the MS530 Woofer/Midrange Driver



Front View of the MS630 Woofer/Midrange Driver

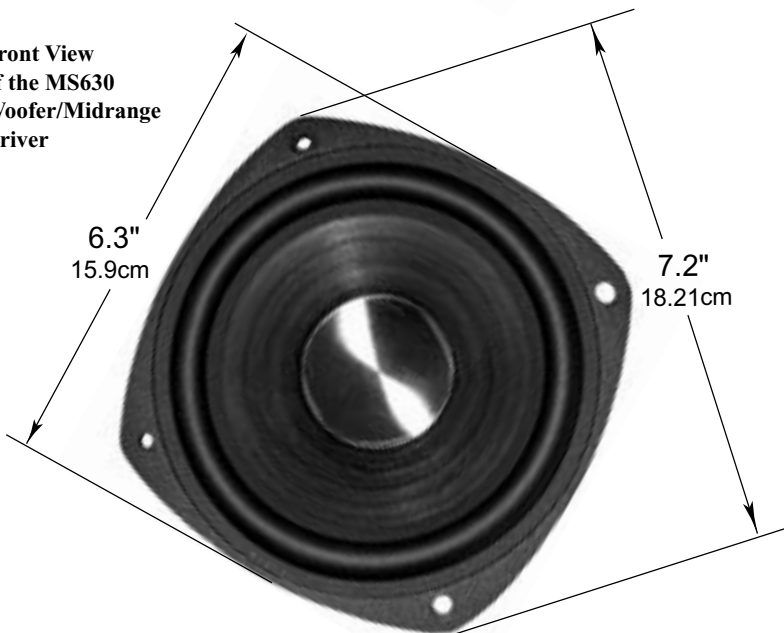

Side View of the MS630 Woofer/Midrange Driver



Installation

It is recommended that a qualified professional install all McIntosh Sound System Products. McIntosh Woofer/Midrange Drivers, Tweeters and Crossover Networks should be used in conjunction with McIntosh Subwoofers and McIntosh Electronics to achieve the best possible performance. McIntosh Subwoofers are designed to operate in the bass frequency range below 120Hz and need not be physically close to Midrange and Tweeter Loudspeakers in order to maintain good imaging and system frequency balance. Another consideration in choosing the location for the Loudspeaker Drivers and Crossover is to mount them away from areas in the vehicle that might have high moisture and temperature.

Mounting the Woofer/Midrange

1. Using the enclosed template as a guide, mark and drill the four pilot holes for the mounting screws. Drill the mounting holes with an appropriate size drill bit.

2. Cut out the marked circle in the template, and using it as a guide, mark and cutout the circular hole for the Loudspeaker in the vehicle panel or suitable enclosure.

3. Place the narrow foam ring gasket in the matching groove of the plastic mounting ring. Refer to figure 1.

4. Carefully lower the Loudspeaker into the plastic mounting ring, with the foam ring side facing the Loudspeaker and making sure the driver mounting holes are aligned with the matching holes in the mounting ring.

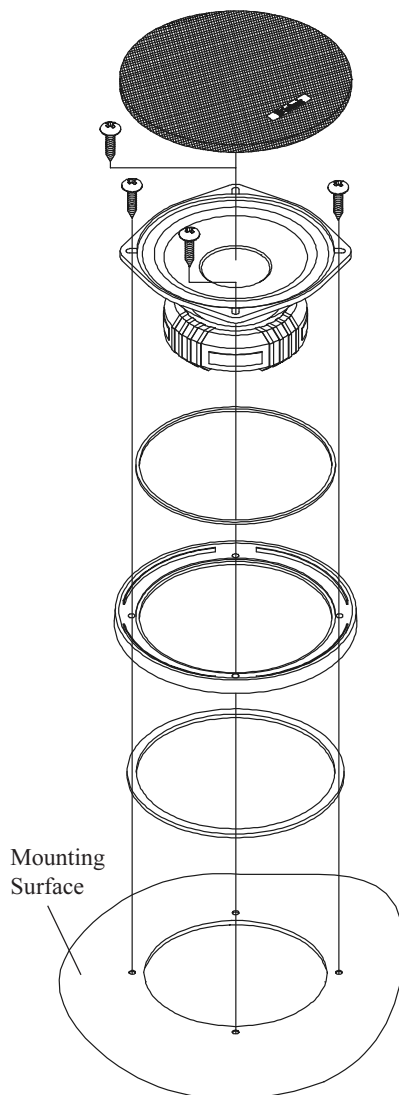

Figure 1

5. Place the wide foam ring gasket on the back side of the plastic mounting ring that will contact the vehicle panel or enclosure.
6. Carefully insert the Loudspeaker and mounting ring assembly into the cutout. Secure the assembly by inserting four of the #8 x 1 inch supplied Sheet Metal Screws, through the driver holes, the plastic mounting ring holes and into the spring clip fasteners previously installed over the mounting holes.
7. Press the metal grille cover into the speaker mounting ring.

Mounting the Tweeter

1. Cut a hole into the mounting surface using the supplied template and then insert the Tweeter Leads into the just cut opening. Refer to figure 2.

Note: If the mounting surface opening is made too large the Tweeter Locking Tabs will be unable to secure the Tweeter to the mounting surface. The minimum mounting surface thickness is 1/16 of an inch. If the Tweeter Leads will not be accessible after inserting them into the mounting opening, then proceed to pages 8 and 9 for connection details before performing the following step.

2. Compress the Locking Tabs as the Tweeter is inserted into the mounting surface.

Note: If it should become necessary to remove the Tweeter from the mounting surface, compress the Locking Tabs at the rear of the Tweeter Magnet Assembly and then push forward on the center of the magnet to extract the Tweeter.

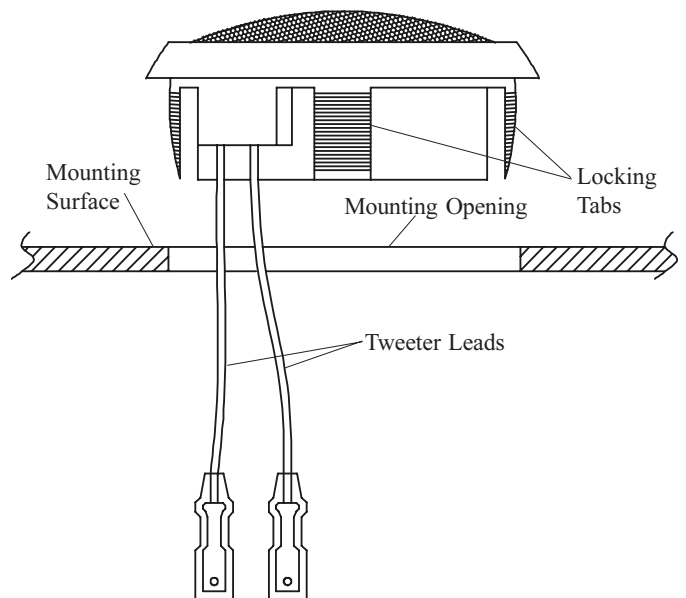

Figure 2

Mounting the Crossover

When selecting a Crossover mounting location, make sure there is adequate room for ventilation (there are openings on both sides of the Crossover) and for making connections to it. Use the supplied screws for mounting the Crossover to the vehicle.

1. Using the Crossover as a template, mark the two locations to drill holes in the mounting surface for the Crossover mounting screws. Drill two holes with an appropriate size drill bit. Refer to figure 3.
2. Secure the Crossover to the mounting surface with the two #6 x 7/8 inch supplied Sheet Metal Screws. Refer to figure 4.
3. Follow instructions for

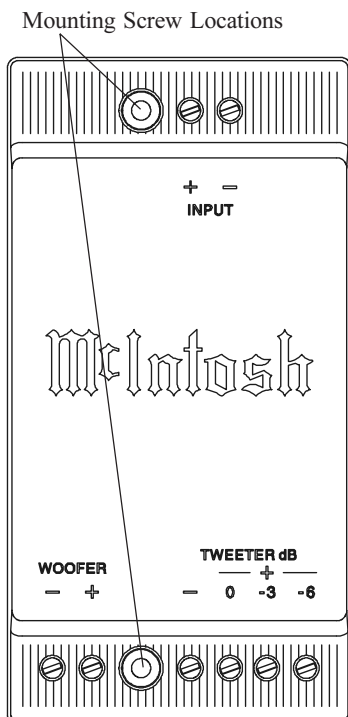

Figure 3

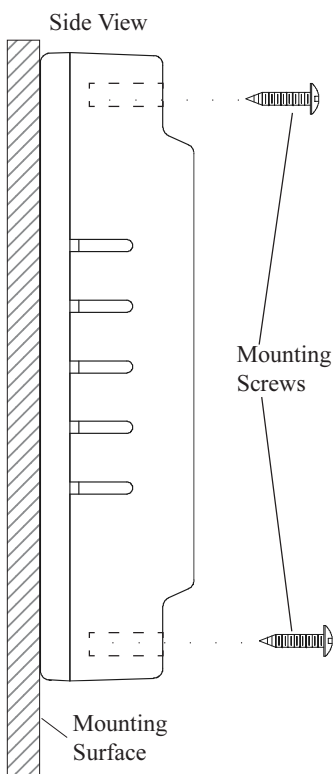
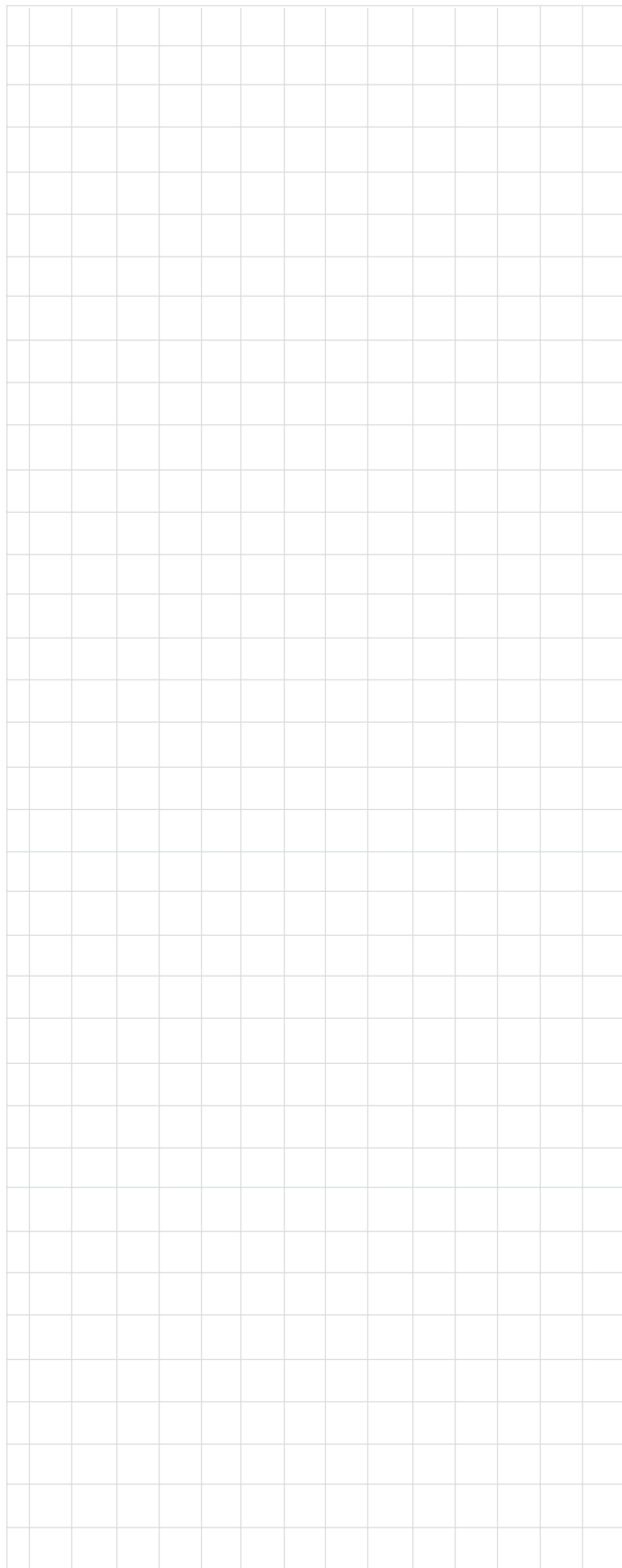

Figure 4

connecting the Crossover to the Loudspeakers on pages 8 and 9.



How to Connect a Two Way System

1. Press the connector ends of the supplied Woofer/Midrange Red/Black cables onto the matching Woofer/Midrange connecting lugs.
2. Attach the other ends of the two Red/Black Woofer/Midrange cables to the Crossover Network WOOFER OUTPUT Terminals. The Black wire connects to a MINUS (-) Terminal and the Red wire to a PLUS (+) Terminal.
3. Attach the connector ends of the supplied Red/Black Tweeter Cables to the Tweeter Leads with connectors, matching the color of the cables.
4. Attach the other ends of the two Red/Black Tweeter Cables to the Crossover Network Tweeter Terminals.

The Black wire connects to a MINUS (-) Terminal and the Red wire to the (0) POSITIVE Terminal.

Note: There are two additional Tweeter Positive Terminal Connections (-3dB and -6dB) that allow for a reduction in High Frequency Output to match the Sound System Environment. Connect the Tweeter Positive (Red) Cable to the -3dB or -6dB Positive Tweeter Output Terminal that produces the preferred sound.

5. Connect the MINUS (-) OUTPUT of a McIntosh 2 Channel Power Amplifier to the Crossover Network MINUS INPUT Terminal and the PLUS (+) OUTPUT to the Crossover Network PLUS (+) INPUT Terminal.

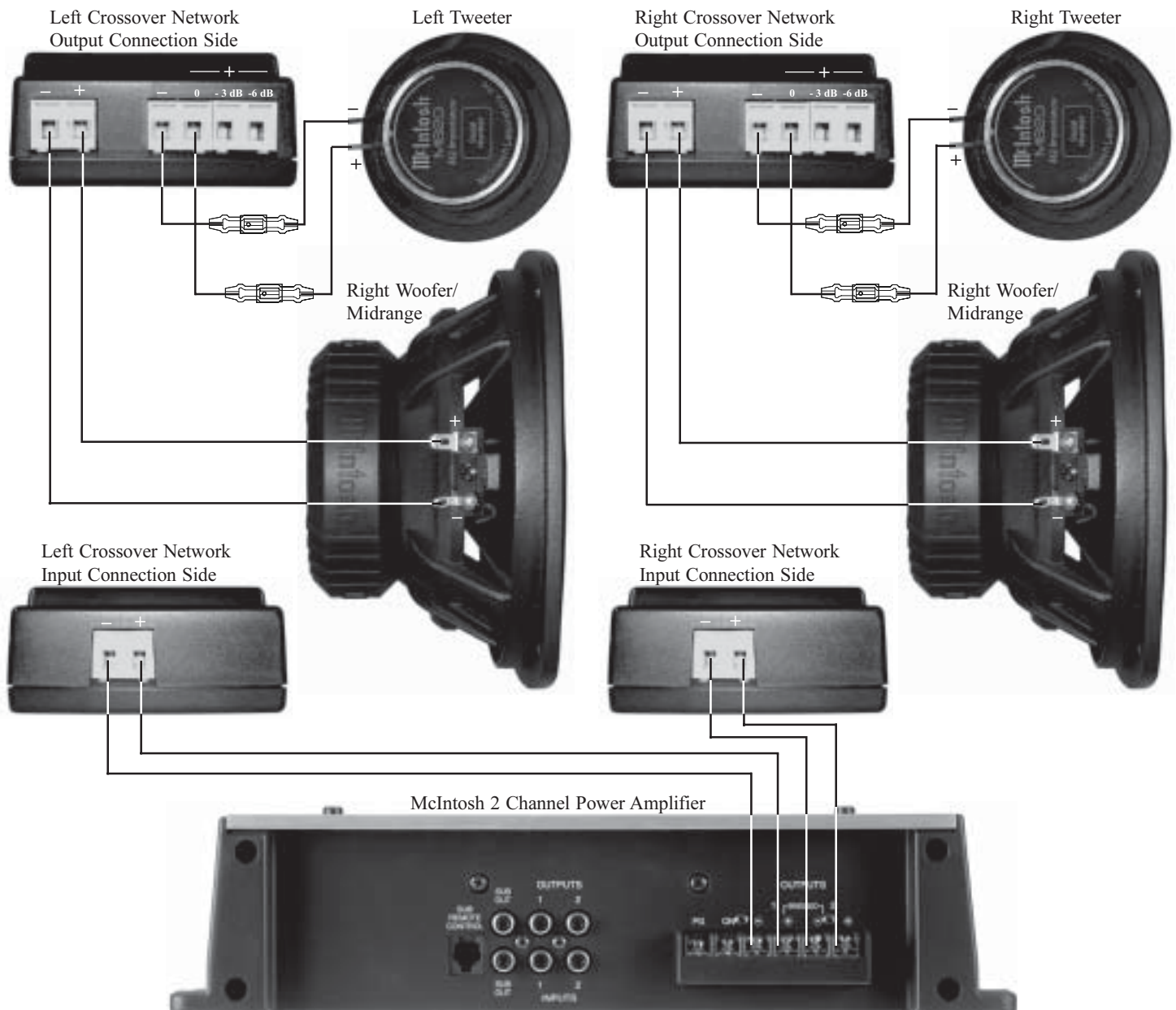

How to Connect a Three Way System

1. Press the connector ends of the supplied Woofer/Midrange Red/Black cables onto the matching Woofer/Midrange connecting lugs.
2. Attach the other ends of the two Red/Black Woofer/Midrange cables to the Crossover Network WOOFER OUTPUT terminals. The Black wire connects to a MINUS (-) Terminal and the Red wire to a PLUS (+) Terminal.
3. Attach the connector ends of the supplied Red/Black Tweeter Cables to the Tweeter Leads with connectors, matching the color of the cables.
4. Attach the other ends of the two Red/Black Tweeter Cables to the Crossover Network Tweeter Terminals.

The Black wire connects to a MINUS (-) Terminal and the Red wire to the (0) POSITIVE Terminal.

Note: There are two additional Tweeter Positive Terminal Connections (-3dB and -6dB) that allow for a reduction in High Frequency Output to match the Sound System Environment. Connect the Tweeter Positive (Red) Cable to the -3dB or -6dB Positive Tweeter Output Terminal that produces the preferred sound.

5. Connect the MINUS (-) OUTPUT of a McIntosh Power Amplifier to the Crossover Network MINUS INPUT Terminal and the PLUS (+) OUTPUT to the Crossover Network PLUS (+) INPUT Terminal.
6. Connect the Optional McIntosh Subwoofer to the appropriate Power Amplifier Output Terminals.

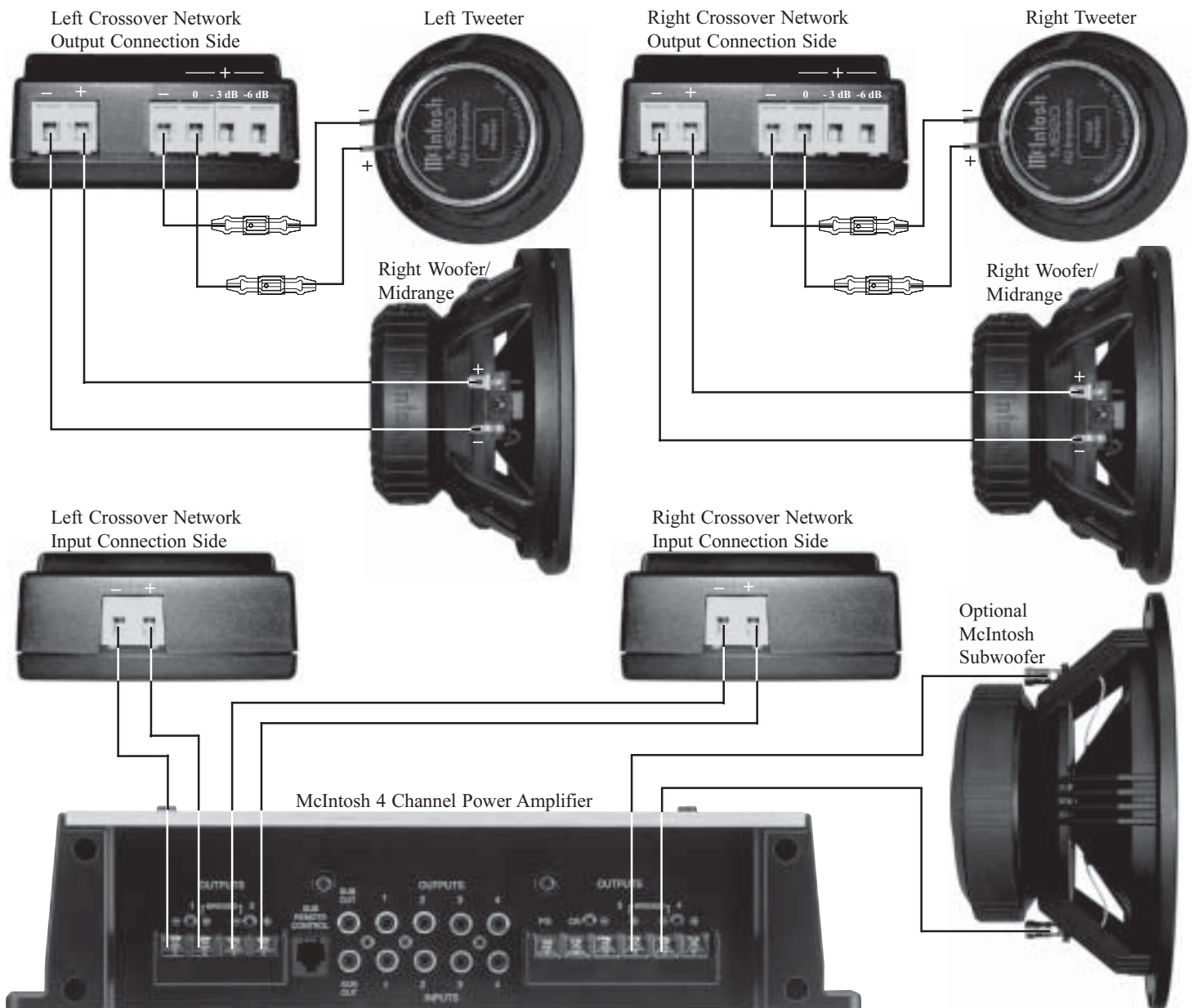

MSS530 System Specifications

System Parameters

Peak Power	120 Watts
Continuous Power (EIA + H.P.)	60 Watts
Frequency Response	80 Hz - 20kHz
System Sensitivity ¹	85 dB
Nominal Impedance (Znom)	4 Ohms
Crossover Frequency	2400 Hz
Low Pass Slope	12 db/oct
High Pass Slope	12 db/oct

MS530 Woofer/Midrange

Mounting Dimensions

Grille Overall (Diameter)	6-9/16" (166.7mm)
Speaker + Grille Overall Depth	3-7/16" (87.3mm)
Speaker Mounting Depth	2-3/4" (70mm)
Mounting Hole Diameter	4-3/4" (121mm)

MS20 Tweeter

Mounting Dimensions

Housing Overall (Diameter)	2-1/8" (54mm)
Speaker + Grille Overall Depth	7/8" (22.2mm)
Speaker Mounting Depth	9/16" (14.2mm)
Mounting Hole Diameter	1-3/4" (44.5mm)

MN530 Crossover

Mounting Dimensions

Width	2.7" (6.86mm)
Height	5.2" (13.20mm)
Depth	1.4" (3.4mm)

MSS530 System Weight

In Shipping Carton (pair)	8.6 lbs.(3.9kg)
---------------------------	-----------------

¹ The System Sensitivity includes the Woofer/Midrange Driver, Tweeter Driver and Crossover Network.

MSS630 System Specifications

System Parameters

Peak Power	120 Watts
Continuous Power (EIA + H.P.)	60 Watts
Frequency Response	80 Hz - 20kHz
System Sensitivity ¹	85 dB
Nominal Impedance (Znom)	4 Ohms
Crossover Frequency	2500 Hz
Low Pass Slope	12 db/oct
High Pass Slope	12 db/oct

MS630 Woofer/Midrange

Mounting Dimensions

Grille Overall (Diameter)	7-5/8" (194mm)
Speaker + Grille Overall Depth	3-15/16" (100mm)
Speaker Mounting Depth	3" (76mm)
Mounting Hole Diameter	5-7/8" (149mm)

MS20 Tweeter

Mounting Dimensions

Housing Overall (Diameter)	2-1/8" (54mm)
Speaker + Grille Overall Depth	7/8" (22.2mm)
Speaker Mounting Depth	9/16" (14.2mm)
Mounting Hole Diameter	1-3/4" (44.5mm)

MN630 Crossover

Mounting Dimensions

Width	2.7" (6.86mm)
Height	5.2" (13.20mm)
Depth	1.4" (3.4mm)

MSS630 System Weight

In Shipping Carton (pair)	9.5 lbs.(4.3kg)
---------------------------	-----------------

¹ The System Sensitivity includes the Woofer/Midrange Driver, Tweeter Driver and Crossover Network.

Packing Instructions

In the event it is necessary to repack the equipment for shipment, the equipment must be packed exactly as shown below. Use the original shipping carton and interior parts only if they are all in good serviceable condition. If a shipping carton or any of the interior part(s) are needed, please call or write Customer Service Repair Department of McIntosh Laboratory.

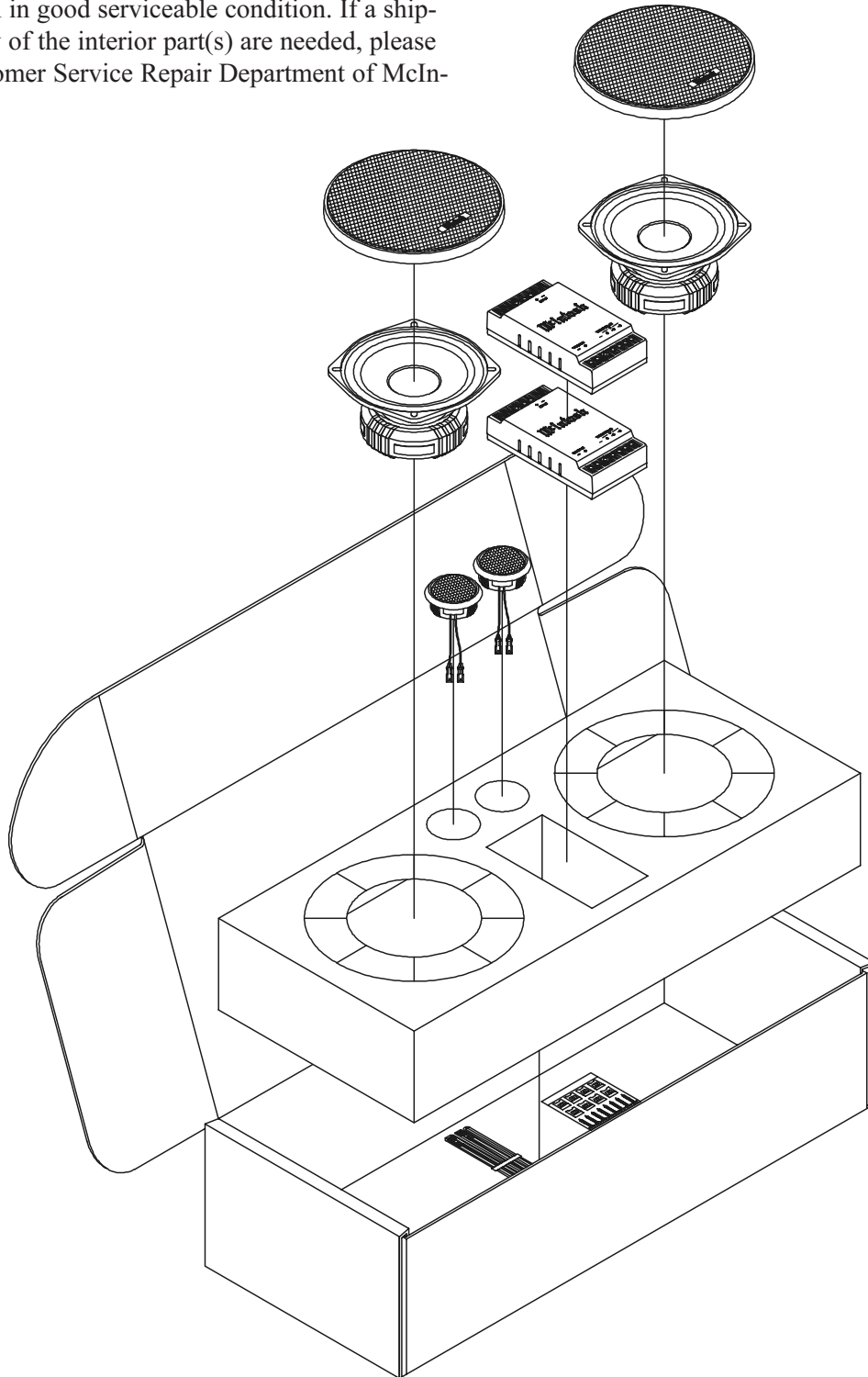

McIntosh[®]

McIntosh Laboratory, Inc.
2 Chambers Street
Binghamton, NY 13903

McIntosh Part No. 040826

Free Manuals Download Website

<http://myh66.com>

<http://usermanuals.us>

<http://www.somanuals.com>

<http://www.4manuals.cc>

<http://www.manual-lib.com>

<http://www.404manual.com>

<http://www.luxmanual.com>

<http://aubethermostatmanual.com>

Golf course search by state

<http://golfingnear.com>

Email search by domain

<http://emailbydomain.com>

Auto manuals search

<http://auto.somanuals.com>

TV manuals search

<http://tv.somanuals.com>