



Integrated Amplifier



MA6600 Owner's Manual

 The HD Radio Ready logo is a proprietary trademark of iBiquity Digital Corp.

The lightning flash with arrowhead, within an equilateral triangle, is intended to alert the user to the presence of uninsulated “dangerous voltage” within the product’s enclosure that may be of sufficient magnitude to constitute a risk of electric shock to persons.



AVIS RISQUE DE CHOC ELECTRIQUE - NE PAS OUVRIR.

The exclamation point within an equilateral triangle is intended to alert the user to the presence of important operating and maintenance (servicing) instructions in the literature accompanying the appliance.

WARNING - TO REDUCE RISK OF FIRE OR ELECTRICAL SHOCK, DO NOT EXPOSE THIS EQUIPMENT TO RAIN OR MOISTURE.

NO USER-SERVICEABLE PARTS INSIDE. REFER SERVICING TO QUALIFIED PERSONNEL.

To prevent the risk of electric shock, do not remove cover or back. No user-serviceable parts inside.

IMPORTANT SAFETY INSTRUCTIONS!

PLEASE READ THEM BEFORE OPERATING THIS EQUIPMENT.

1. Read these instructions.
2. Keep these instructions.
3. Heed all warnings.
4. Follow all instructions.
5. Do not use this apparatus near water.
6. Clean only with a dry cloth.
7. Do not block any ventilation openings. Install in accordance with the manufacturer’s instructions.
8. Do not install near any heat sources such as radiators, heat registers, stoves, or other apparatus (including amplifiers) that produce heat.
9. Do not defeat the safety purpose of the polarized or grounding-type plug. A polarized plug has two blades with one wider than the other. A grounding type plug has two blades and a third grounding prong. The wide blade or the third prong are provided for your safety. If the provided plug does not fit into your outlet, consult an electrician for replacement of the obsolete outlet.
10. Protect the power cord from being walked on or pinched particularly at plugs, convenience receptacles, and the point where they exit from the apparatus.
11. Only use attachments/accessories specified by the manufacturer.
12. Use only with the cart, stand, tripod, bracket, or table specified by the manufacturer, or sold with the apparatus. When a cart is used, use caution when moving the cart/apparatus combination to avoid injury from tip-over. 
13. Unplug this apparatus during lightning storms or when unused for long periods of time.
14. Refer all servicing to qualified service personnel. Servicing is required when the apparatus has been damaged in any way, such as power-supply cord or plug is damaged, liquid has been spilled or objects have fallen into the apparatus, the apparatus has been exposed to rain or moisture, does not operate normally, or has been dropped.
15. Do not expose this equipment to dripping or splashing and ensure that no objects filled with liquids, such as vases, are placed on the equipment.
16. To completely disconnect this equipment from the a.c. mains, disconnect the power supply cord plug from the a.c. receptacle.
17. The mains plug of the power supply cord shall remain readily operable.
18. Do not expose batteries to excessive heat such as sunshine, fire or the like.

Thank You

Your decision to own this McIntosh MA6600 Integrated Amplifier ranks you at the very top among discriminating music listeners. You now have “The Best.” The McIntosh dedication to “Quality,” is assurance that you will receive many years of musical enjoyment from this unit. Please take a short time to read the information in this manual. We want you to be as familiar as possible with all the features and functions of your new McIntosh.

Please Take A Moment

The serial number, purchase date and McIntosh Dealer name are important to you for possible insurance claim or future service. The spaces below have been provided for you to record that information:

Serial Number: _____

Purchase Date: _____

Dealer Name: _____

Technical Assistance

If at any time you have questions about your McIntosh product, contact your McIntosh Dealer who is familiar with your McIntosh equipment and any other brands that may be part of your system. If you or your Dealer wish additional help concerning a suspected problem, you can receive technical assistance for all McIntosh products at:

McIntosh Laboratory, Inc.
2 Chambers Street
Binghamton, New York 13903
Phone: 607-723-1545
Fax: 607-724-0549

Customer Service

If it is determined that your McIntosh product is in need of repair, you can return it to your Dealer. You can also return it to the McIntosh Laboratory Service Department. For assistance on factory repair return procedure, contact the McIntosh Service Department at:

McIntosh Laboratory, Inc.
2 Chambers Street
Binghamton, New York 13903
Phone: 607-723-3515
Fax: 607-723-1917

Copyright 2008 © by McIntosh Laboratory, Inc.

Table of Contents

Safety Instructions	2
Thank You and Please Take a Moment.....	3
Technical Assistance and Customer Service	3
Table of Contents	3
General Information	3
Connector and Cable Information	4
Introduction.....	4
Performance Features	4
Dimensions	5
Installation	6
Rear Panel Connections.....	7
Connecting Components.....	8
Connection Diagrams (Separate Sheet).....	Mc1A/1B
Connecting Loudspeakers	9
Remote Control Push-buttons.....	10
How to Operate by Remote Control	11
Front Panel Displays, Controls, Push-buttons and Jack .	12
How to Operate the MA6600	13-20
Specifications.....	22
Packing Instructions	23

General Information

1. For additional connection information, refer to the owner’s manual(s) for any component(s) connected to the MA6600 Integrated Amplifier.
2. The Main AC Power going to the MA6600 and any other McIntosh Component(s) should not be applied until all the system components are connected together. Failure to do so could result in malfunctioning of some or all of the system’s normal operations. When the MA6600 and other McIntosh Components are in their Standby Power Off Mode, the Microprocessor’s Circuitry inside each component is active and communication is occurring between them.
3. The type and availability of tuner module(s) for the MA6600 varies from country to country. Contact your McIntosh Dealer for additional information.
4. In the event the MA6600 Power Amplifier overheats, due to improper ventilation and/or high ambient temperature, the protection circuits will activate. The Front Panel Power Guard LEDs will continuously indicate ON and the audio will be muted. When the MA6600 has returned to a safe operating temperature, normal operation will resume.

If the MA6600 Power Transformer overheats, the MA6600 will switch Off and the Front Panel Output 1 and 2 LED will flash. When the Power Transformer returns to a safe operating temperature the STANDBY/ ON Push-button will become active again.

Connector and Cable Information

XLR Connectors

Below is the Pin configuration for the XLR Balanced Input Connectors on the MA6600. Refer to the diagram for connection:

- PIN 1: Shield/Ground
- PIN 2: + Output
- PIN 3: - Output

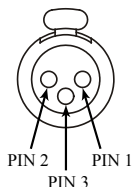

Power Control Connector

The MA6600 Power Control Output Jack sends Power On/Off Signals when connected to other McIntosh Components. A 1/8 inch stereo mini phone plug is used for connection to the Power Control Output on the MA6600.

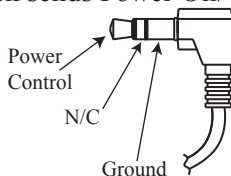

Note: The Data and Power Control Connecting Cable is available from the McIntosh Parts Department:

Data and Power Control Cable Part No. 170-202

Six foot, shielded 2 conductor, with 1/8 inch stereo mini phone plugs on each end.

Data Port Connectors

The MA6600 Data Out Ports send Remote Control Signals to McIntosh Source Components. A 1/8 inch stereo mini phone plug is used for connection.

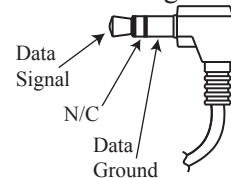

McIntosh Plug-In Jumper Connector

The MA6600 utilizes a phono style Plug-In Jumper to connect the OUTPUT 1 (Preamplifier Output) Jack to the PWR AMP (Power Amplifier Input) Jack for each channel.

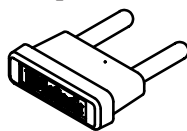

Note: The Jumper Connector is available from the McIntosh Parts Department:

McIntosh Jumper Connector Part No. 117-781

Introduction

Now you can take advantage of traditional McIntosh standards of excellence in the MA6600 Integrated Amplifier. The Power Amplifier section of the MA6600, with a power output of 200 watts per channel, will drive a pair of quality Loudspeakers to a high level of performance. The flexible Preamplifier section provides connections for various input sources and may also be used to drive an external Power Amplifier. The MA6600 reproduction is sonically transparent and absolutely accurate. The McIntosh Sound is "The Sound of the Music Itself."

Performance Features

• Power Output with Patented Autoformer

The MA6600 consists of a 200 watts per channel stereo Power Amplifier with less than 0.005% distortion. The McIntosh designed and manufactured Autoformer allows connection of 2, 4 or 8 ohm Loudspeakers. The Power Amplifier uses Thermal Trak¹ Output Transistors for lower distortion and cool operation.

• Electronic Switching and Balanced Connections

The Preamplifier uses Logic Circuits controlling Electro-magnetic Switches on all inputs and operating functions for reliable, noiseless, distortion free switching. There is a Balanced Input for connection of source components.

• Power Guard

The patented McIntosh Power Guard circuit prevents the amplifier clipping and protects your valuable Loudspeakers.

• Multifunction Fluorescent Display

The Front Panel Display indicates source selection, volume levels, tone adjustments, setup functions and tuner functions when the optional Tuner Module² is installed.

• Illuminated Power Meters

The Illuminated Power Output Watt Meters on the MA6600 are peak responding, and indicate the power output of the amplifier.

• Power Control and Remote Control

The Power Control Output connection provides convenient Turn-On/Off of McIntosh Source Components. The Data Ports together with the supplied Remote Control provides control of McIntosh Source Components connected to the MA6600.

• Special Power Supply

The large Power Transformer, multiple filter capacitors with 100 Jules of Energy Storage and regulated Power Supply ensures stable noise free operation even though the power line varies.

• Fiber Optic Solid State Front Panel Illumination

The even Illumination of the Front Panel is accomplished by the combination of custom designed Fiber Optic Light Diffusers and extra long life Light Emitting Diodes (LEDs). The glass Front Panel ensures the pristine beauty of the MA6600 will be retained for many years.

¹ ThermalTrak™ and ON Semiconductor are trademarks of Semiconductor Components Industries, LLC

² The type and availability of tuner module(s) for the MA6600 varies from country to country.

Dimensions

The following dimensions can assist in determining the best location for your MA6600. There is additional information on the next page pertaining to installing the MA6600 into cabinets.

Front View of the MA6600

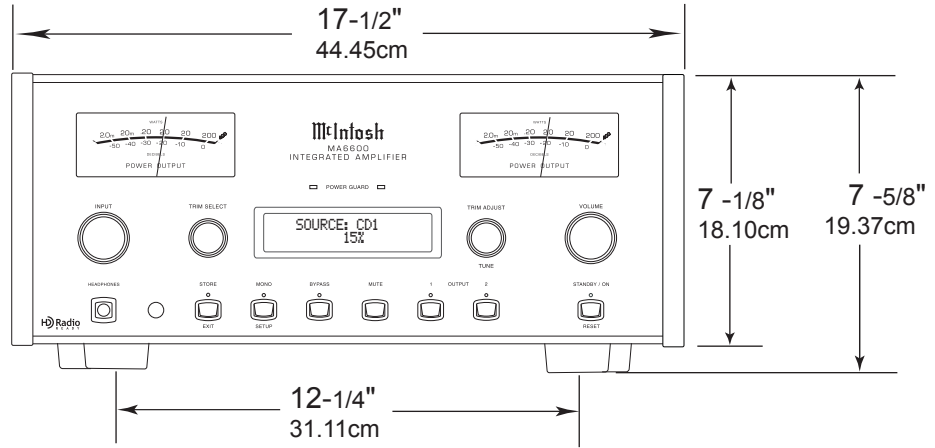

Rear View of the MA6600

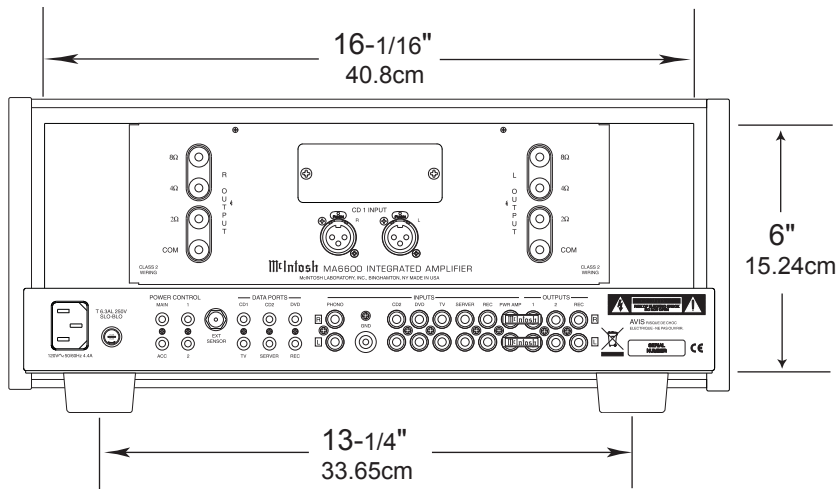

Side View of the MA6600

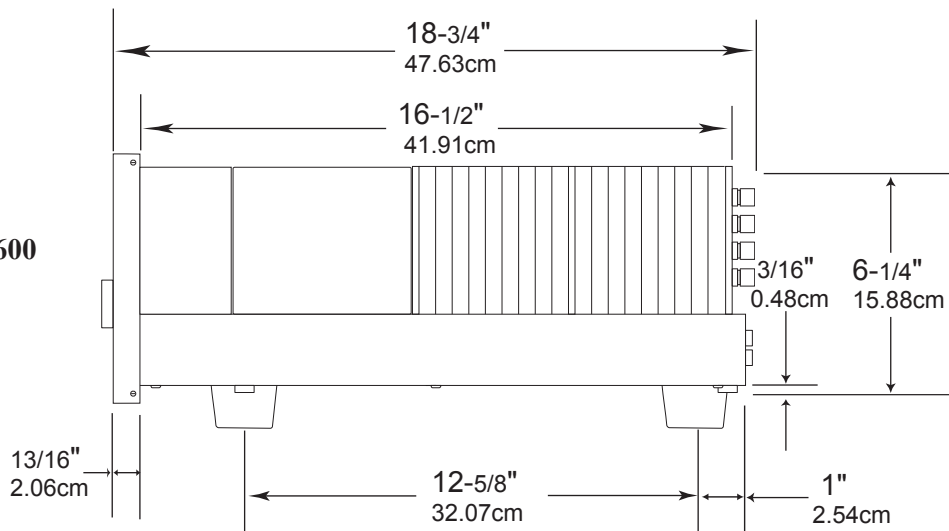

Installation

The MA6600 can be placed upright on a table or shelf, standing on its four feet. It also can be custom installed in a piece of furniture or cabinet of your choice. The four feet may be removed from the bottom of the MA6600 when it is custom installed as outlined below. The four feet together with the mounting screws should be retained for possible future use if the MA6600 is removed from the custom installation and used free standing. The required panel cutout, ventilation cutout and unit dimensions are shown.

Always provide adequate ventilation for your MA6600. Cool operation ensures the longest possible operating life for any electronic instrument. Do not install the MA6600 directly above a heat generating component such as a high powered amplifier. If all the components are installed in a single cabinet, a quiet running ventilation fan can be a definite asset in maintaining all the system components at the coolest possible operating temperature. A custom cabinet installation should provide the following minimum spacing dimensions for cool operation.

Allow at least 6 inches (15.24cm) above the top, 2 inches (5.08cm) below the bottom and 1 inch (2.54cm) on each side of the Integrated Amplifier, so that airflow is not obstructed. Allow 20 inches (50.8cm) depth behind the front panel. Allow 2-1/4 inch (5.72cm) in front of the mounting panel for handle clearance. Be sure to cut out a ventilation hole in the mounting shelf according to the dimensions in the drawing.

MA6600 Front Panel Custom Cabinet Cutout

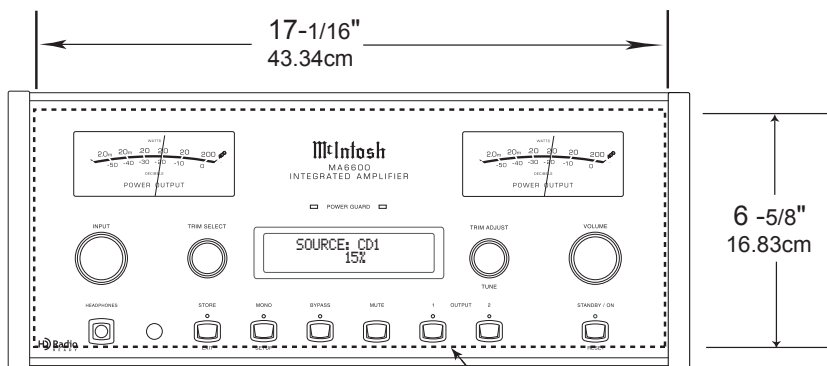

MA6600 Side View in Custom Cabinet

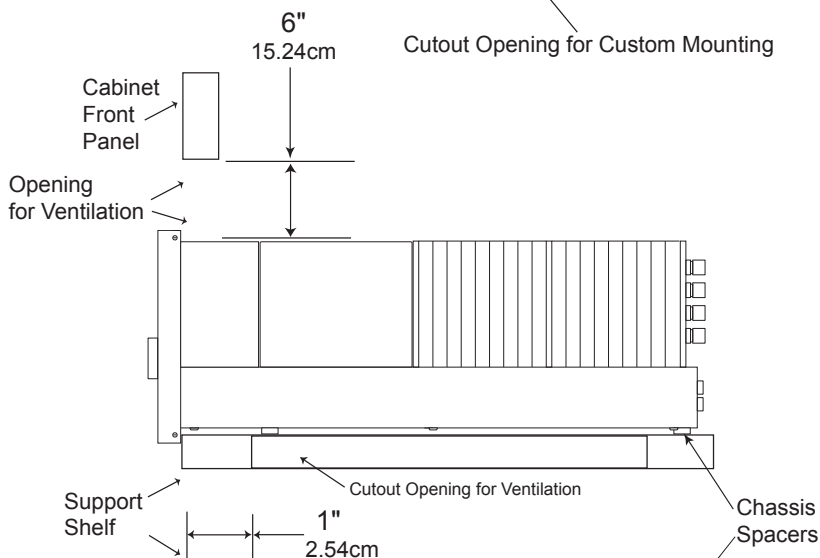

MA6600 Bottom View in Custom Cabinet

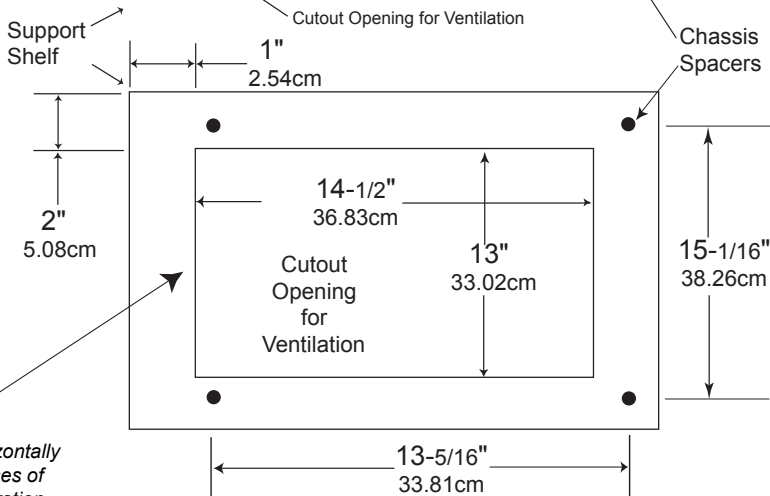

Note: Center the cutout horizontally on the unit. For purposes of clarity, the above illustration is not drawn to scale.

Rear Panel Connections

Connect the MA6600 power cord to a live AC outlet. Refer to information on the back panel of your MA6600 to determine the correct voltage for your unit

RIGHT OUTPUT connections for a 2, 4 or 8 ohm loudspeaker

CD1 Balanced INPUTS accept high level program source signals

CD2, DVD, TV, SERVER and REC INPUTS accept high level program source signals

RECORD OUTPUT sends signals to the input of a recording device

POWER CONTROL MAIN Output sends a turn-on signal to a McIntosh Component when the MA6600 is turned On

DATA PORTS send signals to McIntosh Source Components to allow control with the MA6600 Remote Control

Reserved for the installation of optional Tuner Module

LEFT OUTPUT connections for a 2, 4 or 8 ohm loudspeaker

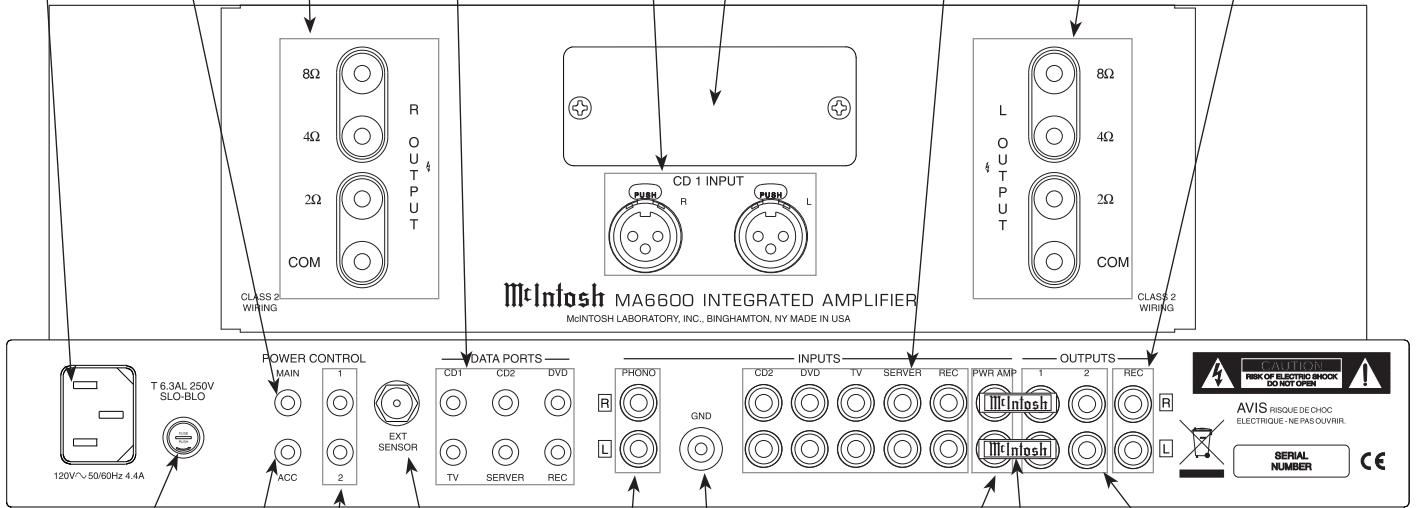

Main Fuse holder, refer to information on the back panel of your MA6600 to determine the correct fuse size and rating

POWER CONTROL 1 and 2 Output sends a turn-on signal to a McIntosh Component when the Outputs 1 and 2 Push-buttons are used

PHONO accepts signals from a Moving Magnet phono cartridge

PWR AMP input accepts signals from the internal Preamplifier or a separate external Preamplifier

OUTPUT 1 sends signals to the internal Power Amplifier or a separate external Power Amplifier; OUTPUT 2 sends signals to a separate external Power Amplifier input

POWER CONTROL ACC Output sends a turn-On, turn-Off signal to a McIntosh Component when using the MA6600 Remote Control ACC On/Off Push-buttons

EXT SENSOR connector permits the connection of a McIntosh IR Sensor for remote operation

GND terminal accepts a ground wire from a turntable

JUMPER PLUGS connect the Preamplifier OUTPUT 1 Jacks to the PWR AMP IN Jacks and are needed for normal operation



Connecting Components

The MA6600 has the ability to automatically switch power On/Off to McIntosh Source Components via the Power Control connections. The Data Port Connections allow for the remote operation of basic functions using the MA6600 Remote Control. With an external sensor connected to the MA6600, remote control operation of the system is possible from another room and/or when the MA6600 is located in a cabinet with the doors closed.

The connection instructions below, together with the MA6600 Input and Output Connection Diagrams located on the separate folded sheet "Mc1A/1B", are an example of a typical audio system. Your system may vary from this, however the actual components would be connected in a similar manner. For additional information refer to "Connector and Cable Information" on page 4.

Power Control Connections:

1. Connect a Control Cable from the MA6600 POWER CONTROL MAIN Jack to the Power Control In on the McIntosh Turntable.
2. Connect a Control Cable from the McIntosh Turntable Power Control Out Jack to the McIntosh Audio/Video Player Power Control In Jack.
3. Connect a Control Cable from the McIntosh Audio/Video Player Power Control Out Jack to the McIntosh SACD/CD Player Power Control In Jack.
4. Connect a Control Cable from the McIntosh SACD/CD Player Power Control Out Jack to the McIntosh Music Server Power Control In Jack.
5. Optionally connect a Control Cable from the MA6600 POWER CONTROL OUTPUT 2 Jack to the McIntosh Power Amplifier (Secondary Room) Power Control In Jack.
6. Connect any additional McIntosh Components in a similar manner, as outlined in steps 1 thru 4.

Data Control Connections:

7. Connect a Control Cable from the MA6600 CD DATA PORT Jack to the McIntosh SACD/CD Player Data In Jack.
8. Connect a Control Cable from the MA6600 SERVER DATA PORT Jack to the McIntosh Music Server Data In Jack.
9. Connect a Control Cable from the MA6600 DVD DATA PORT Jack to the McIntosh Audio/Video Player Data In Jack.
10. Connect any additional McIntosh Components in a similar manner, as outlined in steps 7 thru 10.

Sensor Connections:

11. Connect a RG59U or RG6U Cable from the MA6600 EXT SENSOR "F" Connector to the McIntosh Sensor "F" Connector.

Audio Connections:

12. Connect Balanced Cables from the MA6600 CD 1 INPUT Jacks to the McIntosh SACD/CD Player Fixed Balanced Output Jacks.
13. Connect an Audio Cable from the MA6600 SERVER INPUT Jacks to the McIntosh Music Server Output Jacks.
14. Connect an Audio Cable from the MA6600 REC OUTPUT Jacks to the McIntosh Music Server Input 3 Jacks.
15. Connect Audio Cables from the MA6600 DVD INPUT Jacks to the McIntosh Audio/Video Player Output Jacks.
16. Connect the Audio Cables coming from the Turntable to the MA6600 PHONO INPUT Jacks.
17. Optionally, connect Audio Cables from the MA6600 OUTPUT 2 Jacks to the McIntosh Power Amplifier (Secondary) Input Jacks.
18. Connect any additional McIntosh Components in a similar manner, as outlined in steps 12 thru 17.

Ground Connections:

19. Connect the Ground Cable coming from the Turntable to the MA6600 GND Binding Post.

AC Power Cords Connections:

20. Connect the MA6600 and any remaining components' AC Power Cords to a live AC outlet as illustrated.

Connecting Loudspeakers

Caution: *The supplied AC Power Cord should not be connected to the Rear Panel of the MA6600 Amplifier until after the Loudspeaker Connections have been made. Failure to observe this could result in Electric Shock. For additional instruction on making Loudspeaker Connections contact your McIntosh Dealer or McIntosh Technical Support.*

When connecting Loudspeakers to the MA6600 it is very important to use cables of adequate size, so there is little to no power loss in the cables. The size is specified in Gauge Numbers or AWG (American Wire Gauge). The smaller the Gauge number, the larger the wire size:

Loudspeaker Cable Distance vs Wire Gauge Guide			
Loudspeaker Impedance	25 feet (7.62 meters) or less	50 feet (15.24 meters) or less	100 feet (30.48 meters) or less
2 Ohms	12AWG	10AWG	8AWG
4 Ohms	14AWG	12AWG	10AWG
8 Ohms	16AWG	14AWG	12AWG

Refer to the Connection Diagram located on the separate folded sheet "Mc1B" when making Loudspeaker Connections to the MA6600. This an example of a typical audio system, your system may vary from this, however the actual Loudspeakers would be connected in a similar manner.

1. This McIntosh MA6600 Integrated Amplifier is designed for the connection of a single Loudspeaker per amplifier channel, with an impedance of 2 ohms, 4 ohms or 8 ohms.

Note: The remaining Loudspeaker Terminals on the Amplifier should not be connected to another Loudspeaker.

2. Prepare the Loudspeaker Hookup Cables that attach to the Amplifier by choosing one of the methods below:

Bare wire cable ends:

Carefully remove sufficient insulation from the cable ends,

refer to figures 1, 2 & 3. If the cable is stranded,

carefully twist the strands together as tightly as possible.

Note: If desired, the twisted ends can be tinned with solder to keep the strands together, or attach spade lug and/or banana connector.

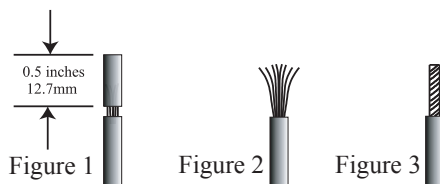

Spade lug or prepared wire connection:

Insert the spade lug connector or prepared section of the cable end into the terminal side access hole, and tighten the terminal cap until the cable is firmly clamped into the terminal so the wires cannot slip out. Refer to figures 4, 5 & 6.

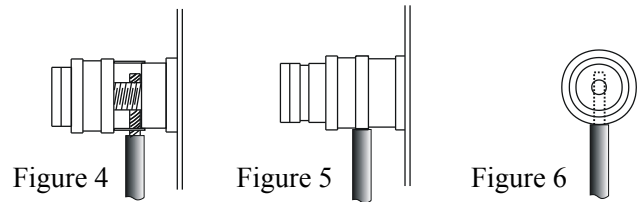

Banana plug connection:

Insert the banana plug into the hole at the top of the terminal. Refer to figures A and B.

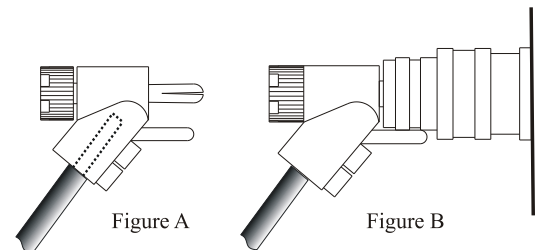

Note: Banana Plugs are for use in the United States and Canada only.

3. Connect the Loudspeaker hookup cables from a single Loudspeaker to the output terminals that match the impedance of the Loudspeaker¹, being careful to observe the correct polarities. Output impedance connections of 2 ohms, 4 ohms and 8 ohms are provided. If the Loudspeaker's impedance is in-between the available connections, use the nearest lower impedance connection.

WARNING: Loudspeaker terminals are hazardous live and present a risk of electric shock.

4. Connect the MA6600 Power Cord to a live AC outlet.

¹For the best performance it is important to minimize an impedance mismatch. An impedance mismatch can occur when a Loudspeaker of a given impedance rating is connected to the MA6600 Output Terminals with a different impedance rating. For example, a Loudspeaker with an impedance rating of 2 Ohm is connected the MA6600 8 Ohm Output Terminals. The impedance of a Loudspeaker actually varies as the Loudspeaker reproduces different frequencies. As a result, the nominal impedance rating of the Loudspeaker (usually measured at a midrange frequency) might not always agree with the impedance of the Loudspeaker at low frequencies where the greatest amount of power is required.

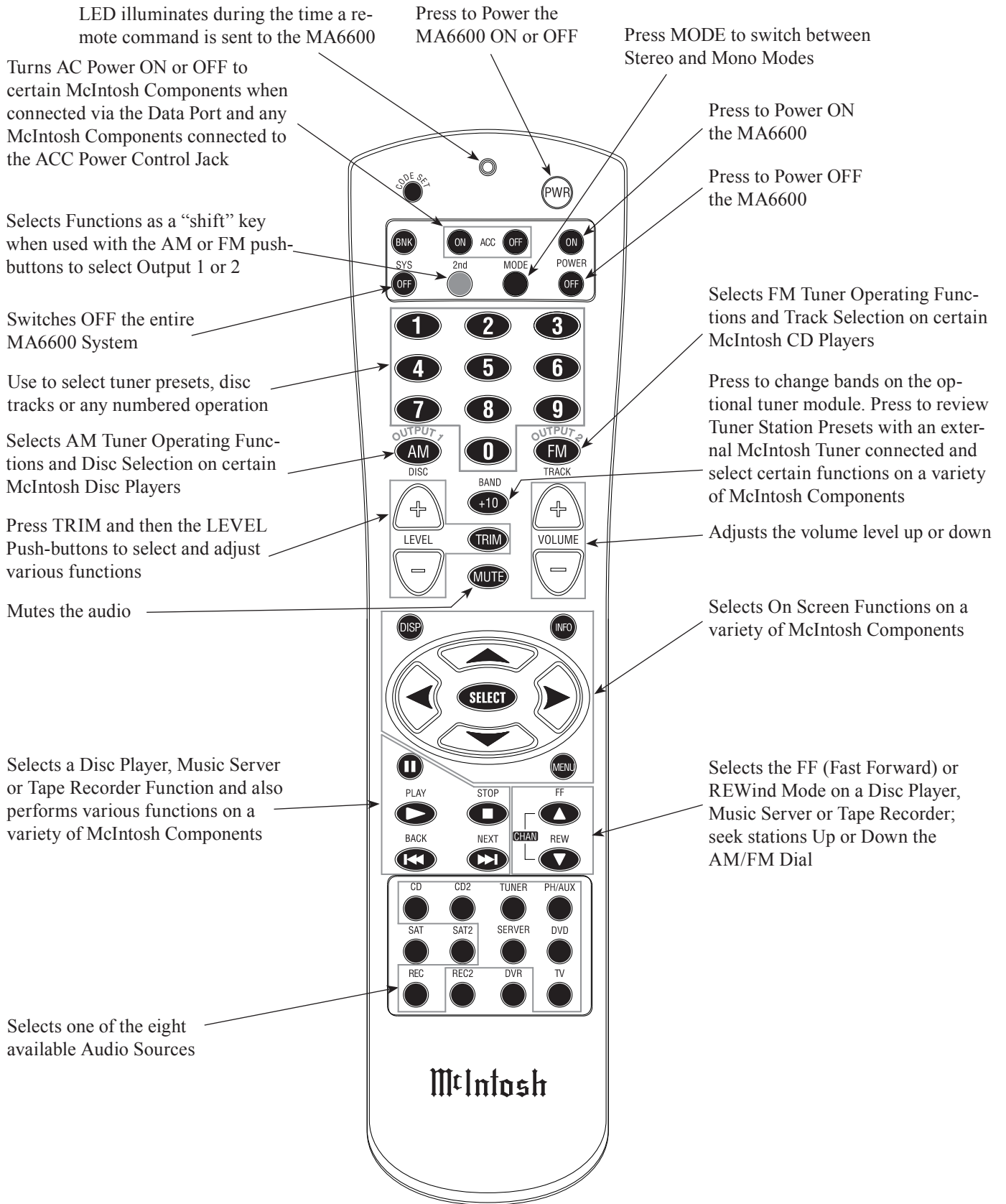

Note: Push-buttons whose function is not identified above are for use with other McIntosh Products.

How to use the Remote Control

The supplied Remote Control is capable of directly controlling the functions of contemporary McIntosh Source Components connected to the MA6600 via the Data Ports.

Input Source Selection

Press the appropriate Source Push-button to select the desired program source.

Mute

Press the MUTE Push-button to mute the audio in all outputs except the REC OUTPUT. The MUTE LED above the push-button will flash on and off to indicate that Mute is active. To un-mute the audio, press the MUTE Push-button again. The mute push-button is also used to activate the special Headphone Mute Mode, refer to page 19 for additional information.

Mono

Press the MONO Push-button to switch from Stereo to Mono for Monophonic listening.

Disc, Server and Tape Functions

Use these push-buttons to operate a DVD Player, CD Player, CD Changer, Music Server or Tape Recorder.

Numbered Push-buttons

Press Push-buttons 0 through 9 to access tuner station presets, tracks on discs or selections on a Music Server.

Disc and Track

Use the DISC and TRACK Push-buttons when a Disc Player or Music Server is being used.

Tuner Push-buttons

Press the AM or FM Push-button to select the desired broadcast band. Press and release the Channel Up▲ or Down▼ Push-button to seek the next available station. Press and hold a Channel Up▲ or Down▼ Push-button to seek continuously from station to station.

Note: When an external McIntosh Tuner is connected to the MA6600, press +10 Push-button to start the automatic brief audition of each of the presets stored in the tuner memory. Press +10 Push-button a second time to stop on a station preset and exit the review process.

Volume

Press the Up▲ or Down▼ VOLUME Push-button to raise or lower the listening volume level.

Note: The Record Signals present at REC OUTPUTS are not affected by volume changes.

Pause

Press the Pause■ Pushbutton to perform various functions on a variety of McIntosh Components. It will also pause the playing of a disc or tape player.

Trim

Press the TRIM Push-button until the desired Trim function (Bass, Balance, Trim Level, Treble, etc.) appears on the Front Panel Information display, then press the LEVEL Up▲ or Down▼ Push-button to adjust the Trim setting.

Press and release the LEVEL Up▲ or Down▼ Push-button to recall the last Trim Function Selected and its current setting, additional pressing of the push-buttons will allow adjustment of the Trim Setting.

Note: For additional information on the Trim Functions refer to pages 16, 17 and 18.

Acc On/Off

Press ACC ON to turn the power ON or ACC OFF switches AC Power ON or OFF to certain McIntosh Components when connected via the Data Port and any McIntosh Components connected to the ACC Power Control Jack.

Amplifier Selection

Press the 2nd Push-button followed by the OUTPUT 1 or 2 Push-buttons either separately or together, to control the rear panel OUTPUTS 1, 2 which can feed signals to a Power Amplifier or other accessory component.

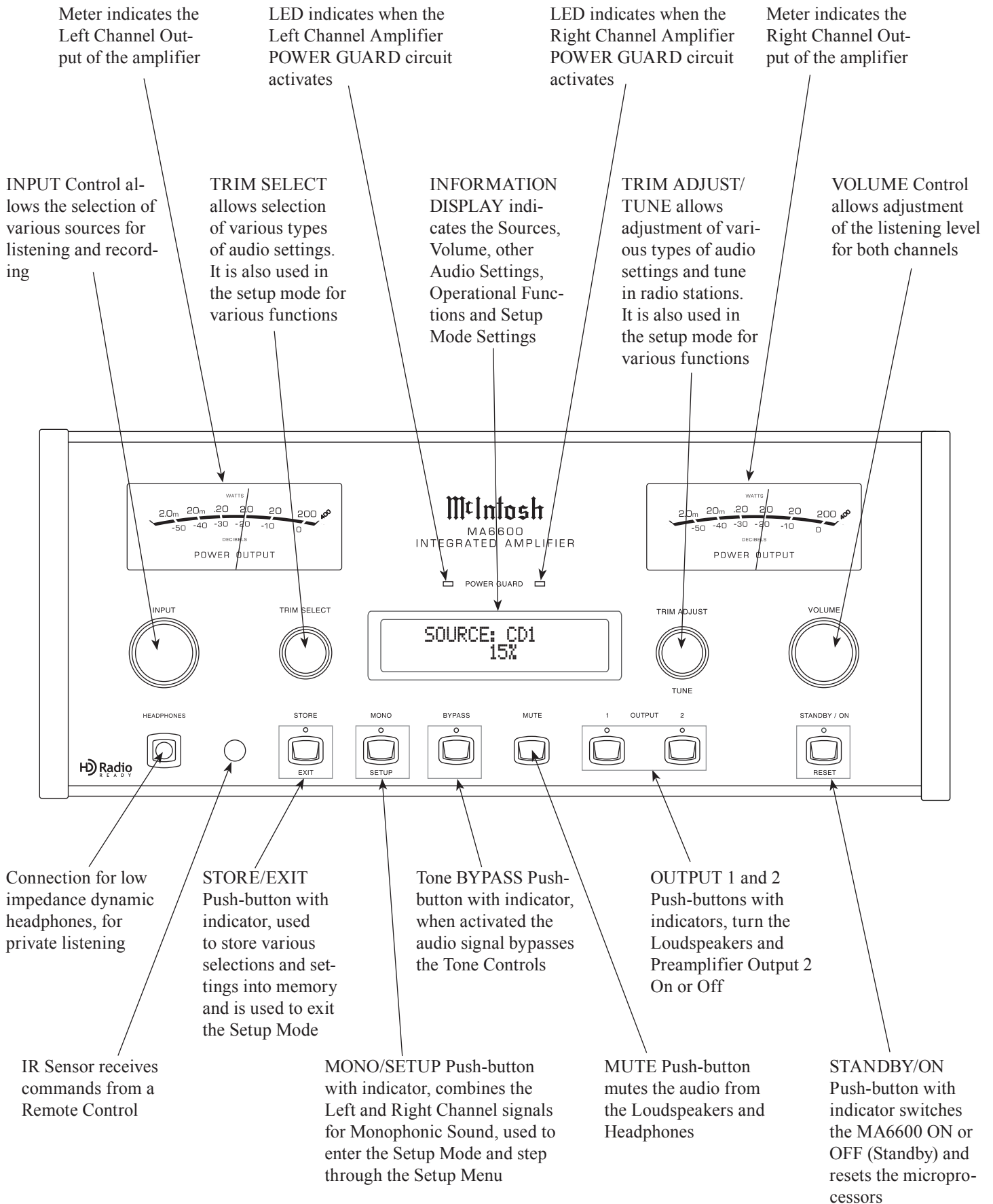

How to Operate the Setup Modes

Your McIntosh MA6600 has been factory configured for default operating settings that will allow immediate enjoyment of superb audio without the need for further adjustments. If you wish to make changes to the factory default settings, a Setup Feature is provided to customize the operating settings using the Front Panel Information Display. Refer to the MA6600 Front Panel Illustration on the previous page while performing the following steps.

Note: If the MA6600 is currently On, proceed to step 2.

1. Press the STANDBY/ON Push-button to switch On the MA6600. The MA6600 will go through a brief startup initialization with the Front Panel Information Display indicating the last used source and volume setting, this is followed by the volume setting indication starting at zero and then increasing to the last used volume setting. Refer to figure 1.
2. Press the MONO/SETUP Push-button until the Front Panel Information Display indicates MA6600 FIRMWARE V1.00 or higher. Refer to figure 2. At this time the LEDs above the MONO/SETUP and STORE/EXIT Push-buttons will be illuminate.



SOURCE: CD1
15%

Figure 1



MA6600
FIRMWARE V1.00

Figure 2

Note: The Front Panel Information Display will indicate MA6600 Firmware V1.00 or higher for the first time. After the first time it will display the Setup Mode Menu item last accessed.

3. Press the MONO/SETUP Push-button to select the next Setup Mode Menu item, "Input Level". With each additional press of the MONO/SETUP Push-button the Setup Menu will advance to the next Menu Selection. Refer to figure 3.
4. To exit from a specific Setup Mode, press the STORE/EXIT Push-button. The LED above the MONO/SETUP Push-button and STORE/EXIT Push-button will extinguish and the Front Panel Display will revert back to its normal display. Refer to figure 1.



SETUP: TRIM CD1 0.0
Min II Max

Figure 3

Default Settings

The Default Settings Chart below indicates the Function Name, Default Setting and the Page Number for additional information.

Note: When a McIntosh Tuner Module is installed into the MA6600, additional Setup Settings will become available.

Default Settings		
Function Name	Setting	Page No.
MA6600	V _ _ _	13
TRIM	CD1 0.0	13
INPUT	INPUT2 CD1	14
METER	ON	14
DISPLAY	3	15
TRIGGER	CD1 NONE	15
ACCessory	MAIN	15

Firmware Version

The MA6600 functionality is controlled by internal software that is known as Firmware. The Version of the Firmware in the MA6600 can be identified at any time by utilizing the Setup Mode.

1. Press and hold in the MA6600 Front Panel MONO/SETUP Push-button to enter the Setup Mode.
2. Press the MONO/SETUP Push-button until MA6600 V1.00 or higher appears. Refer to figure 2.
3. The number after the character "V" is the Firmware number.
4. To exit the Setup Mode, press the STORE/EXIT Push-button.

Trim Level Adjustment

Source Components can have slightly different volume levels resulting in the need to readjust the MA6600 Volume Control when switching between different sources. The MA6600 allows the adjustment of levels for each of the Source Inputs for the same relative volume. The CD1 and SERVER Inputs are used in the following example.

Note: The range of adjustment is ± 6 dB. The REC Output Levels are unaffected by any changes in the Level Trim Settings. The Trim adjustments made are retained in permanent memory. They can be changed by performing a new Trim Procedure. The CD1 Input Volume Level can serve as a reference or choose another source frequently listened to. The reference Input Source should be set to a Trim Level of 00.

1. Rotate the INPUT Control to select the CD1 Input and adjust the VOLUME Control to the desired listening level.

2. Press the MONO/SETUP Push-button until the Setup Mode is active. Then press the MONO/SETUP Push-button to select the Setup Menu item “SETUP: TRIM ____ 0.0”.

Refer to figure 4.



Figure 4

3. Rotate the TRIM/SELECT Control until “TRIM CD1 _.” appears on the Front Panel Information Display. If necessary, rotate the TRIM ADJUST Control for CD1 with a setting of “0.0”.

4. Rotate the TRIM SELECT Control until “TRIM SERVER _.” appears on the Front Panel Information Display.

5. Rotate the TRIM ADJUST Control until Listening Volume Level of the SERVER Input is the same as the CD1 Volume Level.

The figure 5 illustration indicates a



Figure 5

-2.5dB decrease in the SERVER Level.

Note: The trim LEVEL +/- Push-buttons on the Remote Control may also be used.

6. Rotate the TRIM SELECT Control until the name of the next Input to be adjusted is displayed.
7. Repeat steps 5 and 6 until all the Inputs with sources connected to the MA6600 have the same relative volume levels when switching between them. Record any changes made to the various inputs from the default settings in the “Input Source Settings” chart below.
8. Press the STORE/EXIT Push-button to exit the Setup Mode.

Input Source Settings				
Input No.	Default Name	New Name	Trim	Trigger
1	PHONO			
2	CD1			
3	CD2			
4	DVD			
5	TV			
6	SERVER			
7	REC			
—		—		—

Re-Title Inputs

The MA6600 provides the ability to change the default Input Names to match the components in your system. In the following example the REC (Input 7) will be renamed and appear as SAT on the Front Panel Information Display.

Notes: 1. One of the high level Inputs may be renamed to AUX or switched Off. If any input is switched Off its name will no longer appear on the Front Panel Information Display when using the INPUT Control, nor is it accessible with the Remote Control.

2. When a high level input is switched Off its name will become available to the remaining high level inputs.
3. The Phono Input is designed for connection of a turntable only and thus the title is not changeable. However, the Phono Input may be switched Off.
4. When the Phono Input (1) is switched off the name “Phono” may be used for another input, however an external phono preamp would be needed to go between the turntable and the high level input “phono” on the MA6600.

1. Press the MONO/SETUP Push-button until the Setup Mode is active. Then press the MONO/SETUP Push-button to select the Setup Menu item “SETUP: INPUT NAME”.

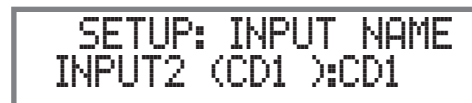

Figure 6

2. Rotate the TRIM/SELECT Control until “INPUT7 (REC): REC” appears on the



Figure 7

3. Rotate the TRIM/TUNE Control until “INPUT7 (REC): SAT” appears on the Front Panel Information Display. Refer to figure 8.



Figure 8

4. Press the STORE/EXIT Push-button to exit the Setup Mode.

Meter Illumination On/Off

The Front Panel Meter Illumination may be switched On or Off. Follow the steps below to switch the Meter Illumination Off.

1. Press the MONO/SETUP Push-button until the Setup Mode is active. Then press the MONO/SETUP Push-button to select the Setup Menu item “SETUP: METER”.

2. Rotate the TRIM ADJUST Control until "LIGHTS: OFF" appears on the Front Panel Information Display. Refer to figure 9.
3. Press the STORE/EXIT Push-button to exit the Setup Mode.



```

SETUP: METER
LIGHTS: OFF

```

Figure 9

Display Brightness

The Front Panel Information Display Brightness may be changed from the default setting. The MA6600 will remember two brightness preferences, one with the Meters Illuminated and one without Meter Illumination. For each preference there are three brightness settings for the Information Display. The Display Brightness setting may be varied 1 (Dim) to 3 (Bright). Follow the steps below for reducing the Display Brightness (with the Meter Illumination On).

1. Press the MONO/SETUP Push-button until the Setup Mode is active. Then press the MONO/SETUP Push-button to select the Setup Menu item "SETUP: DISPLAY".
2. Rotate the TRIM ADJUST Control until "BRIGHTNESS: 1" appears on the Front Panel Information Display. Refer to figure 10.



```

SETUP: DISPLAY
BRIGHTNESS: 1

```

Figure 10

Note: To change the Display Brightness preference with Meter Illumination Off, first switch off the Meter Illumination and change the Display Brightness Setting.

3. Press the STORE/EXIT Push-button to exit the Setup Mode.

Power Control Triggers

The Power Control 1 and 2 Outputs are reassignable to activate only when a given Input is selected. In the following example, the Power Control 1 Output will be set to function as a Trigger for the CDI Input.

1. Press the MONO/SETUP Push-button until the Setup Mode is active. Then press the MONO/SETUP Push-button to select the Setup Menu item "SETUP: TRIGGER".

2. Rotate the TRIM SELECT Control until "CD1 : NONE" appears on the Front Panel Information Display. Refer to figure 11.



```

SETUP: TRIGGER
CD1 : NONE

```

Figure 11

3. Rotate the TRIM ADJUST Control until "CD1 : PC1" appears on the Front Panel Information Display. Refer to figure 12.



```

SETUP: TRIGGER
CD1 : PC1

```

Figure 12

4. Press the STORE/EXIT Push-button to exit the Setup Mode.

Accessory Power Control

The ACC (C) Power Control Output is reassignable from the default setting of going ON/OFF with the MA6600 (Main), to being controlled by the Remote Control ACC ON/OFF Push-buttons. To reassign it perform the following:

1. Press the MONO/SETUP Push-button until the Setup Mode is active. Then press the MONO/SETUP Push-button to select the Setup Menu item "SETUP: ACC TRIGGER". Refer to figure 13.



```

SETUP: ACC TRIGGER
ACC: MAIN

```

Figure 13

2. Rotate the TRIM ADJUST Control until "ACC: REMOTE" appears on the Front Panel Information Display. Refer to figure 14.



```

SETUP: ACC TRIGGER
ACC: REMOTE

```

Figure 14

3. Press the STORE/EXIT Push-button to exit the Setup Mode.



How to Operate the MA6600

Power On

The Red LED above the STANDBY/ON Push-button lights to indicate the MA6600 is in Standby mode. To Switch ON the MA6600, press the STANDBY/ON Push-button on the Front Panel or the Power Push-button on the Remote Control. The MA6600 will go through a brief startup initialization with the Front Panel Information Display indicating the last used source and volume setting, this is followed by the volume setting indication starting at zero and then increasing to the last used volume setting. Refer to figures 15, 17 and 18.



Figure 15

Note: For an explanation of the Remote Control Push-button functions, refer to pages 10 and 11.

Source Selection

Rotate the INPUT Control to select the desired source or press the appropriate push-button switch on the Front Panel or Remote Control. Refer to figures 15, 16 and 17.

Volume Control

Rotate the Front Panel VOLUME Control or use the VOLUME Up▲ or Down▼ Push-buttons on the Remote Control for the desired listening level. Refer to figures 15, 16 and 17.



Figure 16

Trim Functions

The MA6600 has six different Trim Selections with Adjustments. The Trim Selections include Balance, Bass, Treble, Tone Bypass, Input Level Matching and Meter Illumination. The Trim Settings are stored in memory independently for each Input Source Selected, the only exception being Meter Illumination setting of On or Off, which is the same for all inputs.

BALANCE

Listening balance varies with different program sources, room acoustics and listening positions relative to the Loudspeakers. Use the Balance (Trim Function) as needed to achieve approximately equal listening volume levels in each Loudspeaker. To adjust the Balance perform the following:

1. Rotate the Front Panel TRIM SELECT Control or press the TRIM Push-button on the Remote Control until "BALANCE 0 dB" appears on the Front Panel Information Display. Figure 19.

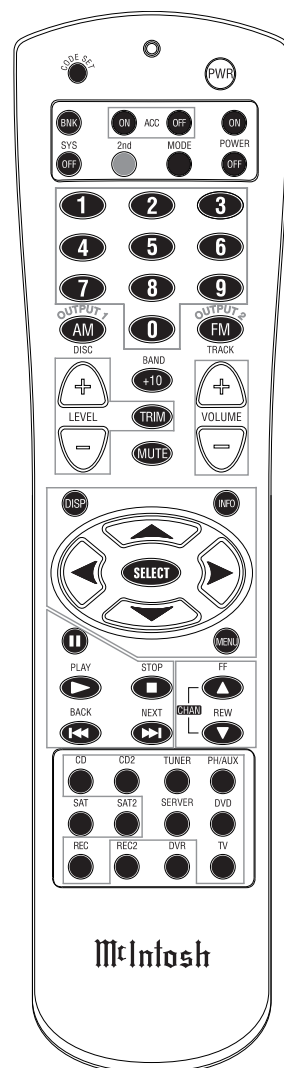

Figure 18

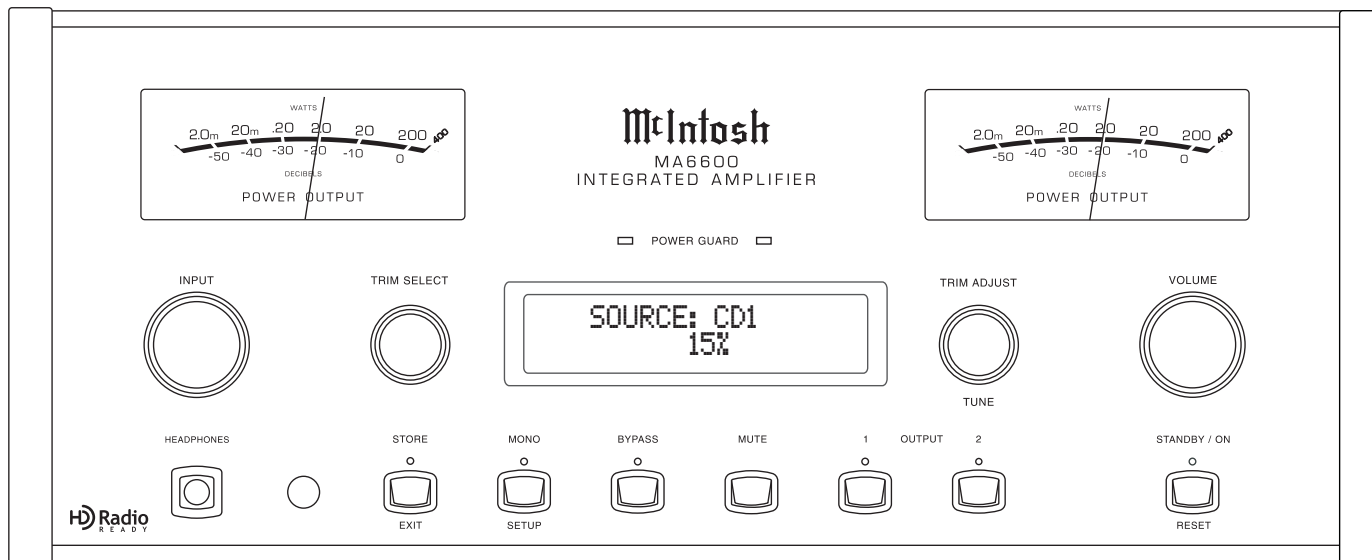

Figure 17

2. Rotate the TRIM ADJUST Control or press the LEVEL + / - Push-buttons to emphasize the Right Channel (refer to figure 20) or the Left Channel (refer to figure 21).



Figure 19



Figure 20



Figure 21

The Front Panel Display indicates the Balance changes in steps from 0 to 50dB. After approximately 3 seconds the Information Display returns to indicate the Source Selection and Volume Level. When the Balance is set to favor either left or right channel, the volume number indicated will have a “< or >” symbol on either side of the number. Refer to figure 22. To verify the Balance setting without changing it, use the TRIM SELECT Control or TRIM Push-button and select Balance.



Figure 22

BASS

The Intensity of the Low Frequencies in the music can be increased or decreased by using the Trim Select and Trim Adjust Controls. To make an adjustment perform the following:

1. Rotate the Front Panel TRIM SELECT Control or press the TRIM Push-button on the Remote Control until “BASS 0 dB” appears on the Front Panel Information Display. Refer to figure 23.
2. Rotate the TRIM ADJUST Control or press the LEVEL + / - Push-buttons to increase (refer to figure 24) or decrease (refer to figure 25) the volume level of the low frequencies.



Figure 23



Figure 24



Figure 25

The Front Panel Display indicates the Bass changes in steps from (+)12dB to -12dB. After approximately 3

seconds the Information Display returns to indicate the Source Selection and Volume Level.

TREBLE

The Intensity of the High Frequencies in the music can be increased or decreased by using the Trim Select and Trim Adjust Controls. To make an adjustment perform the following:

1. Rotate the Front Panel TRIM SELECT Control or press the TRIM Push-button on the Remote Control until “TREBLE 0 dB” appears on the Front Panel Information Display. Refer to figure 26.
2. Rotate the TRIM ADJUST Control or press the LEVEL + / - Push-buttons to increase (refer to figure 27) or decrease (refer to figure 28) the volume level of the high frequencies.



Figure 26



Figure 27



Figure 28

The Front Panel Display indicates the Treble changes in steps from (+)12dB to -12dB. After approximately 3 seconds the Information Display returns to the indicate the Source Selection and Volume Level.

TONE ENABLE/BYPASS

With the Tone Bypass active, the Bass and Treble Settings for the currently selected Input Source are electronically bypassed and the LED above the BYPASS Push-button will illuminate. When the Tone Bypass is switched Off the previous settings for Bass and Treble will be restored. To activate Tone Bypass perform the following:

1. Rotate the Front Panel TRIM SELECT Control or press the TRIM Push-button on the Remote Control until “TONE BYPASS” appears on the Front Panel Information Display. Refer to figure 29.
2. Rotate the TRIM ADJUST Control or press the LEVEL + / - Push-buttons to activate the Tone Bypass or deactivate the Tone Bypass. Refer to figure 30 on the next page.



Figure 29



How to Operate the MA6600, con't

After approximately 3 seconds the Information Display returns to indicate the Source Selection and Volume Level.



Figure 30

TRIM LEVEL

The Trim Level adjustments allow for making fine adjustments to the previously performed Trim Level Adjustments (refer to the Setup Section of this Owner's Manual on page 13). To make fine adjustment to the currently selected Input Source perform the following:

1. Rotate the TRIM SELECT Control or press the TRIM Push-button on the Remote Control until "TRIM LEVEL" appears on the Front Panel Information Display. Refer to figure 31.
2. Rotate the TRIM ADJUST Control or press the LEVEL + / - Push-buttons to adjust the volume level from -6dB to (+) 6dB. Refer to figures 32 and 33.



Figure 31



Figure 32



Figure 33

After approximately 3 seconds the Information Display returns to indicate the Source Selection and Volume Level.

METER ILLUMINATION

The MA6600 Front Panel Meter Illumination may be switched On or Off by performing the following:

1. Rotate the TRIM SELECT Control or press the TRIM Push-button on the Remote Control until "METER" appears on the Front Panel Information Display. Refer to figure 34.
2. Rotate the TRIM ADJUST Control or press the LEVEL + / - Push-buttons to switch On or Off the Meter Illumination. Refer to figure 35.



Figure 34



Figure 35

After approximately 3 seconds the Information Display returns to indicate the Source Selection and Volume Level.

Note: For information on how the Front Panel Information Display Brightness can change with the Meter Illumination setting, refer to page 15 "Display Brightness".

Mono

Press the Front Panel MONO Push-button or the MODE Push-button on the Remote Control to combine left and right stereo signals to a Monophonic signal. The LED

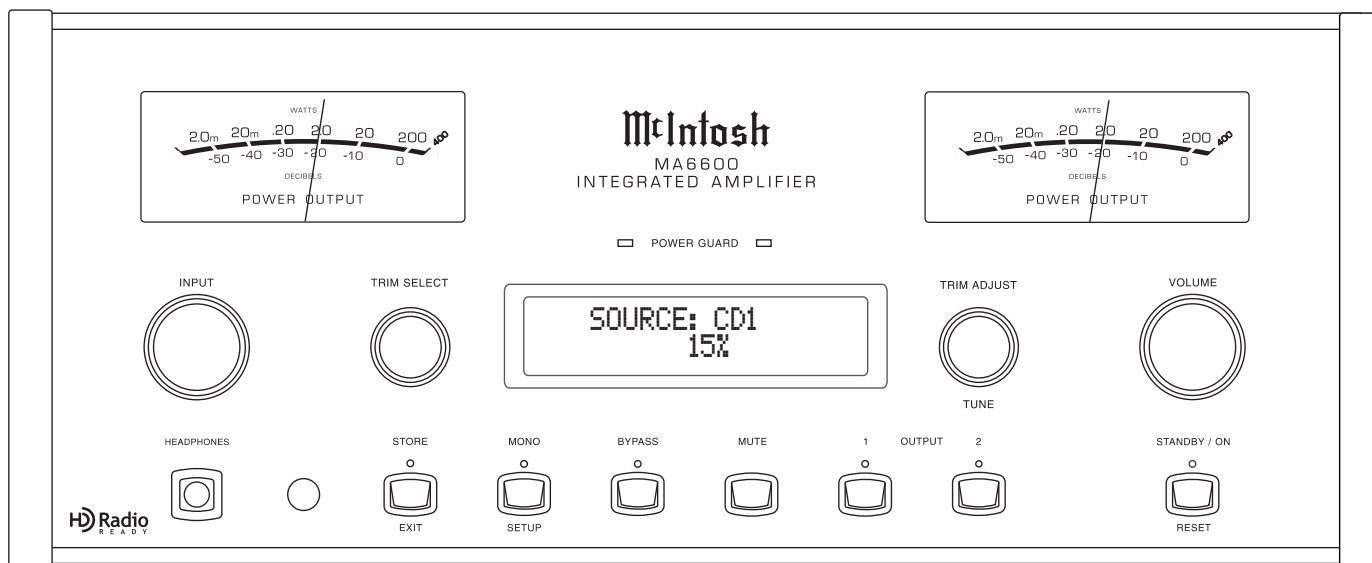

Figure 17

above the MONO Push-button will illuminate. The MA6600 will remember for each input the MONO setting.

Note: The signals at the REC OUTPUT Jacks are not affected.

Mute

Press the MUTE Push-button, on the MA6600 Front Panel or on the Remote Control, to Mute the Audio in all outputs (Output 1, Output 2 and Loudspeakers) except the REC OUTPUT. The Front Panel Information Display will indicate the Source Name and the word MUTE in place of the actual volume setting. Refer to figure 36.



Figure 36

Pressing the Mute Push-button a second time or adjusting the volume control (either the Front Panel or Remote Control) will un-mute the MA6600.

If the Front Panel MUTE Push-button is pressed for at least 3 seconds, the MA6600 will mute the OUTPUT connectors (Output 1 and 2), yet listening with headphones will continue until the Mute Push-button is pressed again for 3 seconds.

The Front Panel Information Display will indicate the Source and Headphone Setting. Refer to figures 37 and 38.



Figure 37



Figure 38

Headphones Jack

Connect a pair of dynamic headphones to the Headphones Jack for private listening. Press OUTPUT 1 and/or 2 Push-buttons to mute the Loudspeakers or use the MUTE Mode Headphone Function outlined above.

Note: The Headphone Output is optimized for impedances ranging from 16 to 250 ohms.

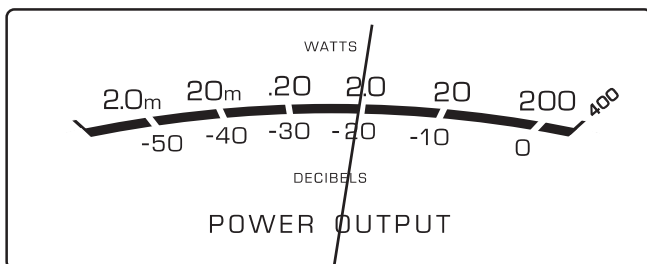

Figure 39

Power Output Meters

The MA6600 Power Output Meters indicate the power delivered to the Loudspeakers. Refer to figure 39. The meters respond to all the musical information being produced by the Amplifier. They indicate to an accuracy of at least 95% of the power output with only a single cycle of a 2,000Hz tone burst.

Power Guard

During normal operation, the Front Panel Power Guard Indicators will momentarily illuminate during peaks in the audio signals. In the event the MA6600 overheats, due to improper ventilation, high ambient temperature and/or impedance mismatch, the internal protection circuits will activate. The Front Panel Power Guard Indicators will continuously illuminate and the audio will be muted. When the MA6600 has returned to a safe operating temperature, normal operation will resume.

How To Make a Recording

1. Select the desired signal source you wish to record by using the Front Panel INPUT Control or the appropriate Source Push-button on the Remote Control.
2. Adjust the record level using the recorder volume control and proceed with the recording process.
3. To listen to the playback of the program source just recorded select the REC Input.

Note: The MA6600 REC OUTPUTS are not affected by the VOLUME, BALANCE or TONE Control Settings.

Using a Separate Power Amplifier

There are two different ways to use a separate power amplifier with a MA6600. The first way is to use the separate amplifier instead of the MA6600 built-in Power Amplifier. Connect the Loudspeakers to the separate power amplifier and remove the McIntosh Jumpers that are located between the OUTPUTS 1 Jacks and the PWR AMP INPUT Jacks. Refer to figure 40 on the next page.

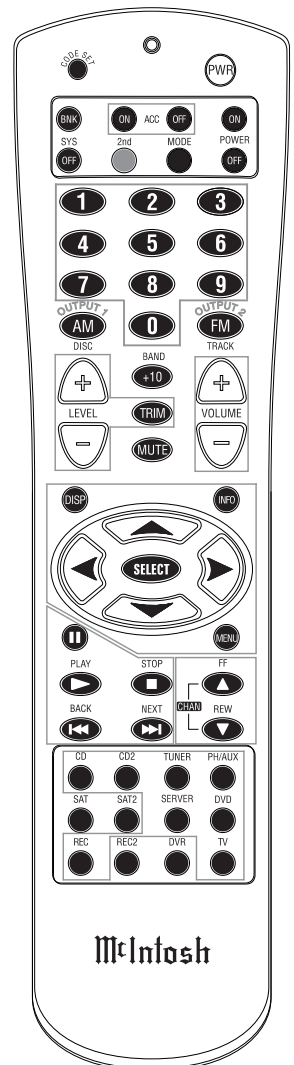

Figure 18

How to Operate the MA6600, con't

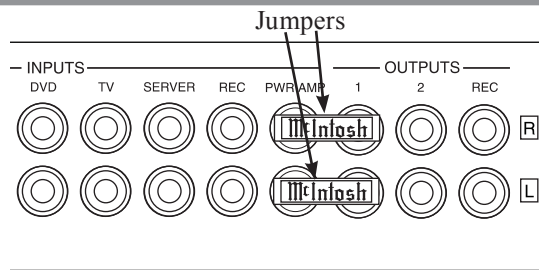

Figure 40

Note: The McIntosh Jumpers must be connected, between the above mentioned jacks, when the MA6600 Internal Power Amplifier is to be used.

The second way is to use both a separate power amplifier and the MA6600 built-in Power Amplifier. Connect one pair of Loudspeakers to the separate power amplifier and the second pair to the MA6600. Refer to the MA6600 Output Connection Diagrams located on the separate folded sheet “Mc1B” and figure 41 below.

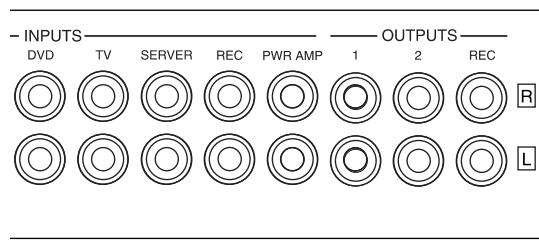

Figure 41

Note: The MA6600 VOLUME Control will affect the sound level of all the Loudspeakers.

Using Output 2

The MA6600 has provisions for connecting an external Power Amplifier (to drive Loudspeakers in another room) and an external sensor for remote operation of the MA6600 from that room. With an external Power Amplifier connected (as illustrated on the McIntosh Connection Diagram separate sheet “Mc1B”), press the Front Panel OUTPUT 2 Push-button or press on the Remote Control the 2nd Push-button followed by pressing the OUTPUT 2 Push-button to switch On or Off the external Power Amplifier.

Reset of Microprocessors

In the unlikely event the controls of the MA6600 stop functioning, the microprocessors can be reset by performing the following:

1. Press the STANDBY/ON Push-button for approximately five seconds.
2. When the MA6600 cycles On then Off, release the STANDBY/ON Push-button.
3. When the STANDBY/ON LED is illuminated press the STANDBY/ON Push-button, the MA6600 will resume normal operation.

Note: This can be performed with the MA6600 On or in the Standby Mode.

Resetting the MA6600 to default settings

If it becomes desirable to reset all the adjustable settings (Setup and Trim Settings) to the factory default values, perform the following:

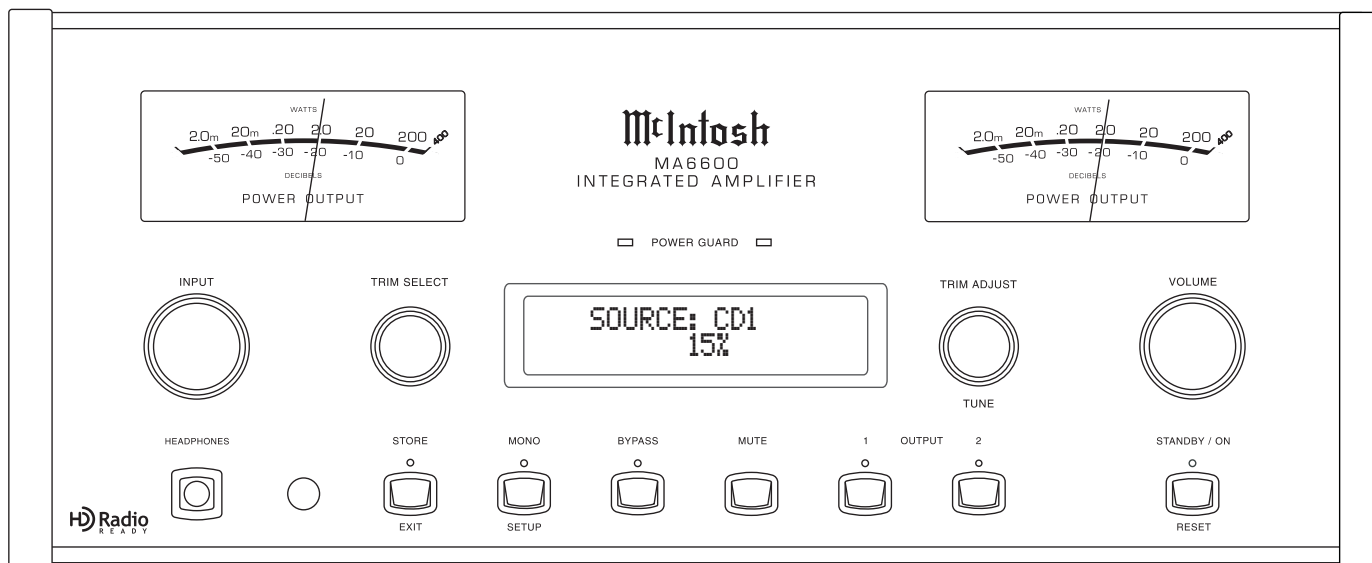
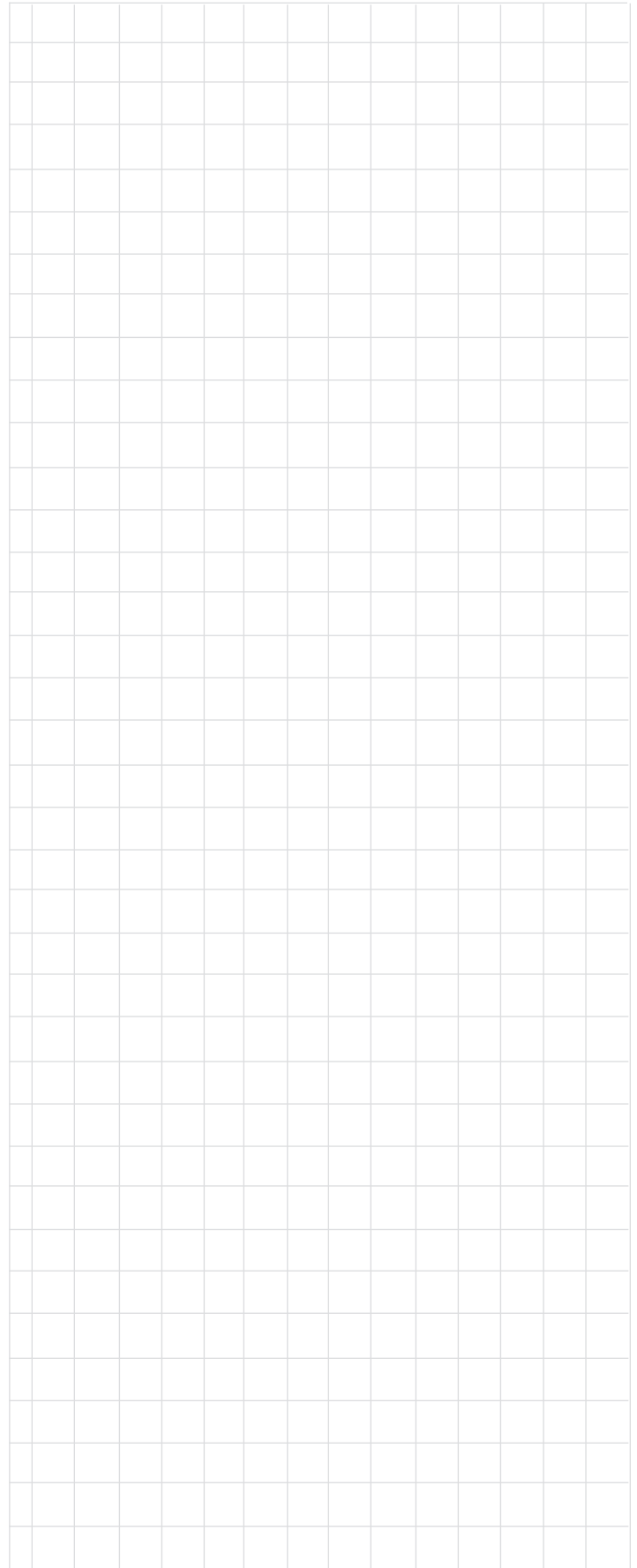

Figure 17

1. Press both the STORE/EXIT and OUTPUT 2 Push-buttons until the Front Panel Display indicates "MASTER RESET" (refer to figure 42), then release the two push-buttons.
2. Press the STANDBY/ON Push-button and the MA6600



Figure 42





Specifications

Power Output

200 watts is the minimum sine wave continuous average power output per channel, both channels operating

Output Load Impedance

2, 4 or 8 ohms

Rated Power Band

20Hz to 20,000Hz

Total Harmonic Distortion

0.005% maximum with both channels operating from 250 milliwatts to rated power, 20Hz to 20,000Hz

Dynamic Headroom

2.0dB

Frequency Response

+0, -0.5dB from 20Hz to 20,000Hz

+0, -3dB from 10Hz to 100,000Hz

Preamplifier Output 1 and 2 (for rated input)

1.4V unbalanced (8V Maximum)

Sensitivity (for rated output)

High Level, 250mV unbalanced, 500mV balanced

Phono, 2.5 mV

Power Amp In, 1.4V

Signal To Noise Ratio (A-Weighted)

High Level, 92dB below rated output

Phono, 84dB below 5mV input

Power Amplifier, 115 below rated output

Intermodulation Distortion

0.005% maximum, if the instantaneous peak power is 400 watts or less per channel with both channels operating for any combination of frequencies from 20Hz to 20,000Hz

Wide Band Damping Factor

Greater than 40

Input Impedance

High Level, 20K ohms

Phono, 47K ohms; 65pF

Power Amp In, 10K ohms

Maximum Input Signal

High Level, 8V unbalanced, 16V balanced

Phono, 80mV

Power Amplifier In, 16V

Preamplifier Output Impedance

220 ohms

Power Guard

Less than 2% THD with up to 16dB overdrive at 1,000Hz

Voltage Gain

High Level to Rec Output: 0dB

High Level to Output 1 and 2: 15dB

Phono to Rec Output: 40dB

Phono to Output 1 and 2: 55dB

Power Amplifier: 29dB

Tone Controls

Bass Control ± 12 dB (1dB steps) @ 30Hz

Treble Control ± 12 dB (1dB steps) @ 10,000Hz

Power Requirements

100 Volts, 50/60Hz at 5.2 amps

110 Volts, 50/60Hz at 4.8 amps

120 Volts, 50/60Hz at 4.4 amps

220 Volts, 50/60Hz at 2.45 amps

230 Volts, 50/60Hz at 2.35 amps

240 Volts, 50/60Hz at 2.25 amps

Standby: Less than 1 watt

Note: Refer to the rear panel of the MA6600 for the correct voltage.

Overall Dimensions

Width is 17-1/2 inches (44.45cm)

Height is 9-7/16 inches (23.97cm) including feet

Depth is 22 inches (55.88cm) including the Front Panel,

Knobs and Cables

Weight

75 pounds (34.1 kg) net, 93 pounds (42.3 kg) in shipping carton

Shipping Carton Dimensions

Width is 29-1/2 inches (74.93cm)

Depth is 29 inches (73.66cm)

Height is 17 inches (43.18cm)

Packing Instructions

In the event it is necessary to repack the equipment for shipment, the equipment must be packed exactly as shown below. It is very important that the four plastic feet are attached to the bottom of the equipment. Two #10 x 2-1/2 inch screws and washers must be used to fasten the unit securely to the bottom pad and wood skid. This will ensure the proper equipment location on the bottom pad. Failure to do this will result in shipping damage.

Use the original shipping carton and interior parts only if they are all in good serviceable condition. If a shipping carton or any of the interior part(s) are needed, please call or write Customer Service Department of McIntosh Laboratory. Refer to page 3. Please see the Part List for the correct part numbers.

Quantity	Part Number	Description
1	033888	Shipping carton
4	033887	End Cap
1	033697	Inner carton
1	033725	Top pad
1	034301	Bottom pad
1	033699	Wood skid
2	017218	Plastic foot (spacer)
2	401204	#10 x 2-1/2 inch wood screw
2	404033	#10 flat washer 1-3/4 inch
4	017937	Plastic foot
4	400159	#10-32 x 3/4 machine screw
4	404080	#10 flat washer

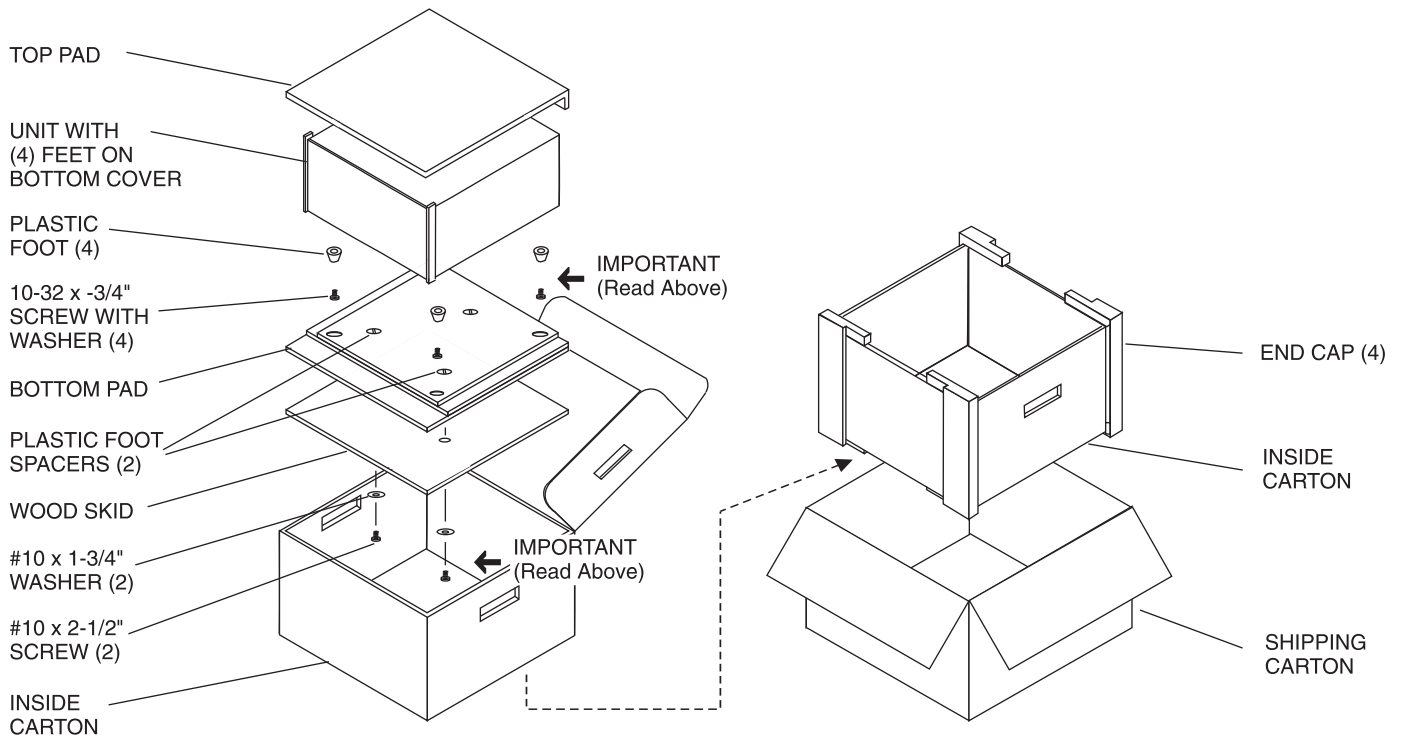



McIntosh Laboratory, Inc.
2 Chambers Street
Binghamton, NY 13903

The continuous improvement of its products is the policy of McIntosh Laboratory Incorporated who reserve the right to improve design without notice. Printed in the U.S.A.

McIntosh Part No. 04107800

Free Manuals Download Website

<http://myh66.com>

<http://usermanuals.us>

<http://www.somanuals.com>

<http://www.4manuals.cc>

<http://www.manual-lib.com>

<http://www.404manual.com>

<http://www.luxmanual.com>

<http://aubethermostatmanual.com>

Golf course search by state

<http://golfingnear.com>

Email search by domain

<http://emailbydomain.com>

Auto manuals search

<http://auto.somanuals.com>

TV manuals search

<http://tv.somanuals.com>