



## Precision Turntable



## MT10 Owner's Manual

The lightning flash with arrowhead, within an equilateral triangle, is intended to alert the user to the presence of uninsulated “dangerous voltage” within the product’s enclosure that may be of sufficient magnitude to constitute a risk of electric shock to persons.



**AVIS** RISQUE DE CHOC ELECTRIQUE - NE PAS OUVRIR.

The exclamation point within an equilateral triangle is intended to alert the user to the presence of important operating and maintenance (servicing) instructions in the literature accompanying the appliance.

**WARNING - TO REDUCE RISK OF FIRE OR ELECTRICAL SHOCK, DO NOT EXPOSE THIS EQUIPMENT TO RAIN OR MOISTURE.**

**NO USER-SERVICEABLE PARTS INSIDE. REFER SERVICING TO QUALIFIED PERSONNEL.**

To prevent the risk of electric shock, do not remove cover or back. No user-serviceable parts inside.

## IMPORTANT SAFETY INSTRUCTIONS!

### PLEASE READ THEM BEFORE OPERATING THIS EQUIPMENT.

1. Read these instructions.
2. Keep these instructions.
3. Heed all warnings.
4. Follow all instructions.
5. Do not use this apparatus near water.
6. Clean only with a dry cloth.
7. Do not block any ventilation openings. Install in accordance with the manufacturer’s instructions.
8. Do not install near any heat sources such as radiators, heat registers, stoves, or other apparatus (including amplifiers) that produce heat.
9. Do not defeat the safety purpose of the polarized or grounding-type plug. A polarized plug has two blades with one wider than the other. A grounding type plug has two blades and a third grounding prong. The wide blade or the third prong are provided for your safety. If the provided plug does not fit into your outlet, consult an electrician for replacement of the obsolete outlet.
10. Protect the power cord from being walked on or pinched particularly at plugs, convenience receptacles, and the point where they exit from the apparatus.
11. Only use attachments/accessories specified by the manufacturer.
12. Use only with the cart, stand, tripod, bracket, or table specified by the manufacturer, or sold with the apparatus. When a cart is used, use caution when moving the cart/apparatus combination to avoid injury from tip-over. 
13. Unplug this apparatus during lightning storms or when unused for long periods of time.
14. Refer all servicing to qualified service personnel. Servicing is required when the apparatus has been damaged in any way, such as power-supply cord or plug is damaged, liquid has been spilled or objects have fallen into the apparatus, the apparatus has been exposed to rain or moisture, does not operate normally, or has been dropped.
15. Do not expose this equipment to dripping or splashing and ensure that no objects filled with liquids, such as vases, are placed on the equipment.
16. To completely disconnect this equipment from the a.c. mains, disconnect the power supply cord plug from the a.c. receptacle.
17. The mains plug of the power supply cord shall remain readily operable.
18. Do not expose batteries to excessive heat such as sunshine, fire or the like.

---

## Thank You

Your decision to own this McIntosh MT10 Precision Turntable and MCC10 Moving Coil Cartridge ranks you at the very top among discriminating music listeners. You now have “The Best.” The McIntosh dedication to “Quality,” is assurance that you will receive many years of musical enjoyment from this unit. Please take a short time to read the information in this manual. We want you to be as familiar as possible with all the features and functions of your new McIntosh.

---

## Please Take A Moment

The serial number, purchase date and McIntosh Dealer name are important to you for possible insurance claim or future service. The spaces below have been provided for you to record the Turntable and Cartridge information:

Dealer Name	Purchase Date	Model Number	Serial Number
		MT10	
		MCC10	

---

## Technical Assistance

If at any time you have questions about your McIntosh product, contact your McIntosh Dealer who is familiar with your McIntosh equipment and any other brands that may be part of your system. If you or your Dealer wish additional help concerning a suspected problem, you can receive technical assistance for all McIntosh products at:

McIntosh Laboratory, Inc.  
2 Chambers Street  
Binghamton, New York 13903  
Phone: 607-723-1545  
Fax: 607-724-0549

---

## Customer Service

If it is determined that your McIntosh product is in need of repair, you can return it to your Dealer. You can also return it to the McIntosh Laboratory Service Department. For assistance on factory repair return procedure, contact the McIntosh Service Department at:

McIntosh Laboratory, Inc.  
2 Chambers Street  
Binghamton, New York 13903  
Phone: 607-723-3515  
Fax: 607-723-1917

Copyright 2007 © by McIntosh Laboratory, Inc.

---

## Table of Contents

---

Safety Instructions .....	2
Thank You and Please Take a Moment.....	3
Technical Assistance and Customer Service .....	3
Table of Contents .....	3
General Information .....	4
Connector and Cable Information .....	4
Introduction.....	5
Performance Features .....	5
Dimensions .....	6
Unpacking the Turntable.....	7
Assembling the Turntable .....	8
Rear Panel Connections and Adjustments.....	11
How to Connect the Turntable.....	12
Front Panel Display, Switches, Lever and Record Clamp .....	13
How to Operate the Turntable.....	14
Specifications.....	18
Packing Instruction.....	19

### General Information

**Caution:** To prevent possible damage to the turntable platter bearing, do not move the MT10 Precision Turntable with the platter installed.

1. For additional connection information, refer to the owner's manual(s) for any component(s) connected to the MT10 Precision Turntable.
2. The MT10 Precision Turntable comes with the McIntosh MCC10 High Performance Moving Coil Cartridge preinstalled.
3. It is recommended the Professionals at your McIntosh Dealer, who are skilled in all aspects of Turntables and Phono Cartridges, install the MT10 Precision Turntable and any associated audio equipment.
4. For optimum performance, the setup and adjustment of the MT10 Precision Turntable requires special test recordings and test/measurement equipment. Contact your McIntosh Dealer for additional information and assistance.

### Connector and Cable Information

#### Power Control Connector

The MT10 Power Control Input/Output Jacks receive/send Power On/Off Signals when connected to other McIntosh Components. A 1/8 inch stereo mini phone plug is used for connection to the Power Control Input/Output on the MT10.

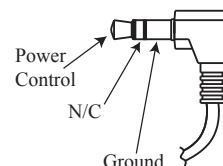

*Note: The Data and Power Control Connecting Cable is available from the McIntosh Parts Department:*

**Data and Power Control Cable Part No. 170-202**

*Six foot, shielded 2 conductor, with 1/8 inch stereo mini phone plugs on each end.*

#### Tonearm Headshell Wiring

Refer to the following list of wire colors in the headshell for installing the cartridge into the Headshell:

<u>Cartridge Connections</u>	<u>Headshell Wire Color</u>
Left Channel (+)	White
Left Channel (-)	Blue
Right Channel (+)	Red
Right Channel (-)	Green

#### McIntosh MCC10 Cartridge Connections

Refer to the following illustration when connecting the McIntosh Cartridge in the Headshell:

**Rear View of McIntosh MCC10 Cartridge**

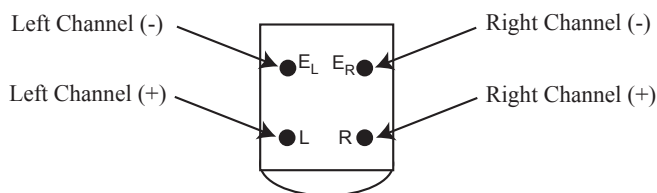

### Introduction

---

The McIntosh MT10 Precision Turntable with the McIntosh MCC10 Moving Coil Cartridge offers the latest in playback of vinyl recordings. A full complement of performance features allows for the enjoyment of all recordings reproduced with flawless realism. The advanced electronic and mechanical design ensures many years of smooth trouble free operation.

### Performance Features

---

#### • Advanced Technology Turntable

The MT10 combines the latest technology in Phono Cartridges, Tone Arms, Mechanical Suspensions and Record Platter Rotation for superb performance and accurate operation.

#### • Moving Coil Cartridge

The McIntosh MCC10 Moving Coil Cartridge has a hand polished ebony wood-tone body and is slightly rounded, leading to a resonance free construction. High impedance, together with high output voltage, ensures noise free musical reproduction. The ruler-flat frequency response from 20Hz to 20kHz provides solid realistic bass, uncolored midrange and natural high frequencies.

#### • Tone Arm

The MT10 Tone Arm is made from Dural-Aluminium with special damping material. The Tone Arm is both light in weight and highly rigid. The noise free Vertical Bearings are made from two high precision ceramic surfaces with damping fluid. The Horizontal Bearing is a gimballed sapphire design.

#### • Turntable Platter

The over twelve pound, two and one-half inch thick platter is made from a special silicone acrylic material. This helps to resist external vibrations from reaching the record during playback and its large mass provides the perfect flywheel action for stable playback speed.

#### • Precision Motor and Drive Electronics

The Swiss made DC Brushless Motor is controlled by a highly refined servo control system. As the Turntable Platter rotates, an optical sensor "reads" the 1595 micro stripes on a disk affixed to the bottom of the platter. This provides precise feedback information to the servo control system thus assuring very accurate speed rotation.

#### • Illuminated Speed Meter

The Illuminated Speed Meter on the MT10 indicates the true rotation speed of the turntable platter.

#### • Magnetic Air Damped Bearing

The MT10 Turntable Platter rotates on a special bearing using magnetic suspension together with a cushion of air to provide vibration free rotation.

#### • Multi-Layered Damped Chassis

The MT10 Turntable Chassis is composed from a Stainless Steel base plate, a thick Aluminium plate, an Acrylic plate and together with internal damping material all help to assure the only sound heard is from the record groove itself.

#### • Power Control

The Power Control Input connection provides convenient Turn-On/Off of the MT10 Front Panel Illumination when connected to a McIntosh System with Power Control.

#### • Fiber Optic Solid State Illumination

The even Illumination of the Front Panel and the Turntable Platter is accomplished by the combination of custom designed Fiber Optic Light Diffusers and extra long life Light Emitting Diodes (LEDs).

#### • Glass Front Panel and Super Mirror Chassis Finish

The famous McIntosh Illuminated Glass Front Panel and the Stainless Steel Chassis with Super Mirror Finish ensure the pristine beauty of the MT10 will be retained for many years.

### Dimensions

The following dimensions can assist in determining the best location for your MT10.

Front View of the MT10

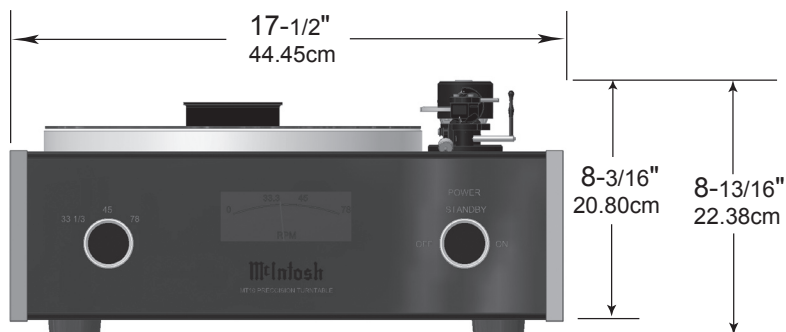

*Note: The above height measurements are with the McIntosh Cartridge installed.*

Rear View of the MT10

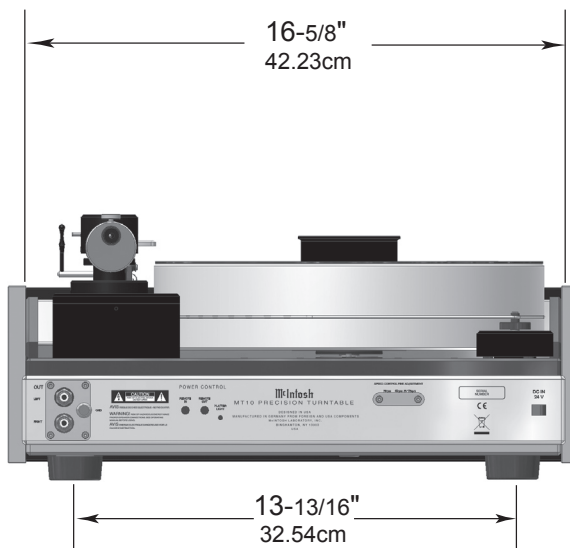

Side View of the MT10

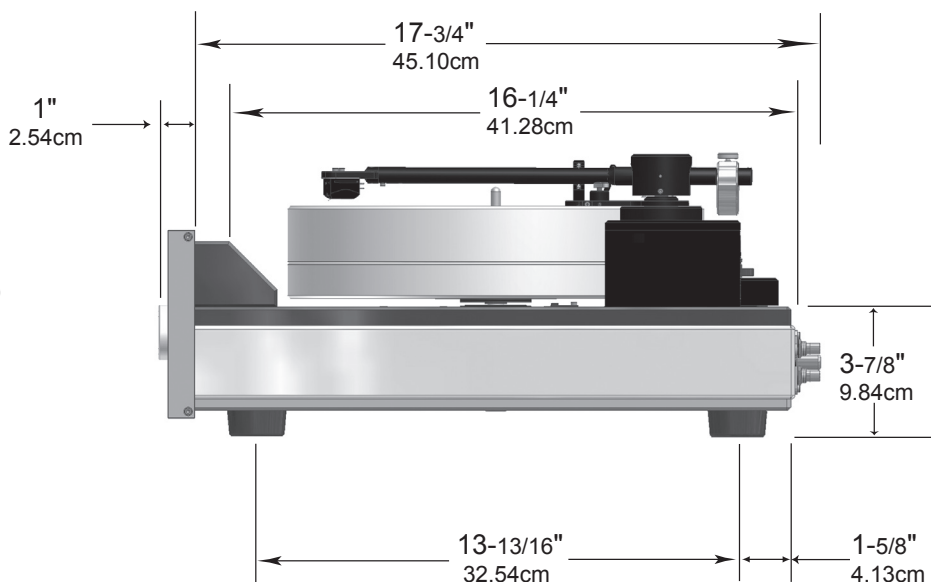

## Unpacking the Turntable

To protect the fine finish of the MT10 Precision Turntable during the assembly and adjustment process, it is advisable to prepare a suitable clean working area with a soft, clean fabric, such as a bed linen or blanket.

It is recommended that the Professionals at your McIntosh Dealer, who are skilled in all aspects of installation and operation, unpack, assemble, adjust and install the MT10 Precision Turntable and any associated audio equipment.

**CAUTION:** To prevent possible damage to the turntable platter bearing, do not move the MT10 Precision Turntable with the platter installed.

1. After opening the outer shipping carton, carefully remove the turntable inner carton (which has two foam end caps) and the turntable platter/accessory inner carton. Refer to figure 1.
2. Open the turntable inner carton and remove the top foam pad. Refer to figure 2.
3. Carefully lift up on the sides of the turntable and remove it from the turntable inner carton.
4. Open the turntable platter/accessory carton and remove the the turntable platter. Refer to Figure 3

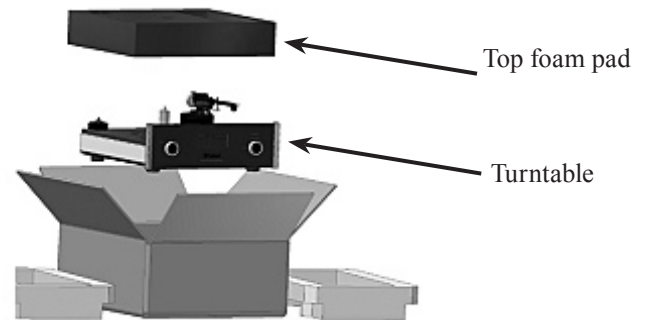
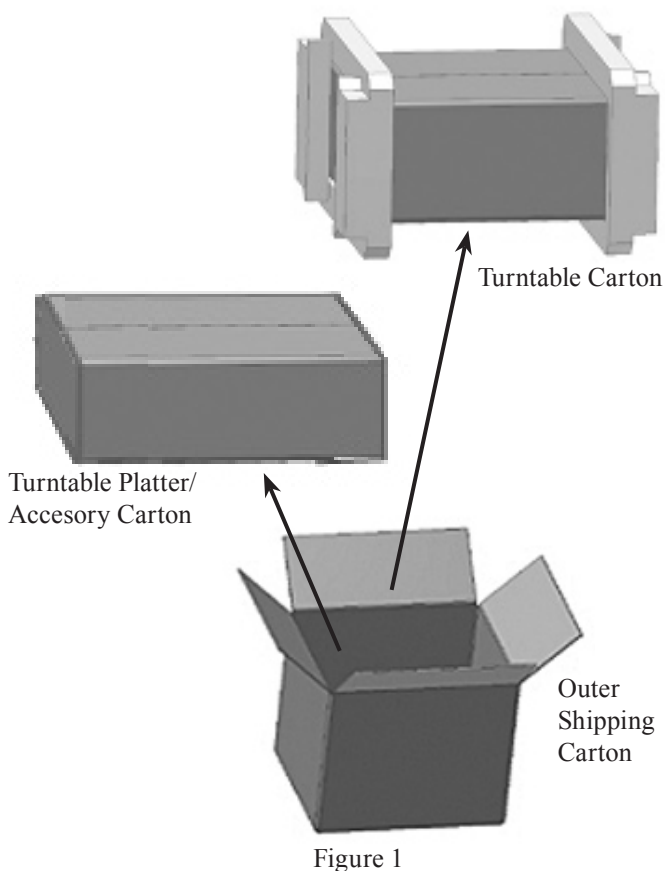

Figure 2

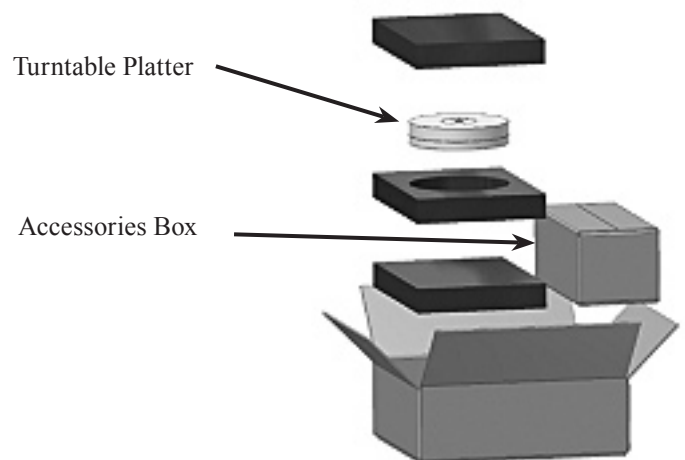

Figure 3

5. Open the accessories box and check to make sure the following items are inside:
  - A. McIntosh MCC10 Moving Coil Cartridge.
  - B. External Power Supply.
  - C. Tonearm Counter Weight.
  - D. Turntable Record Clamp.
  - E. Turntable Bubble Level.
  - F. Assembly/Adjustment Tools.
  - G. Cartridge Mounting Hardware.
  - H. Pair of cloth gloves.
  - I. Turntable Bearing Oil (full-synthetic).
  - J. Tone Arm Height Gauge (used for MCC10 Cartridge).
  - K. Protractor.
  - M. Cloth Dust Cover
  - N. Turntable Platter Mat.

*Note: The Turntable Platter Mat is located in an album cover and in the Accessory box.*

6. Proceed to Assembly of the Turntable starting on the next page.

## Assembling the Turntable

Locate the McIntosh MCC10 Moving Coil Cartridge, Tools and Mounting Hardware from the Accessory Box. In the following steps the Cartridge will be installed in the Tone Arm Headshell of the Turntable.

**CAUTION:** To prevent possible damage to the Cartridge Stylus, DO NOT remove the clear protective cover at this time.

- Using an appropriate tool, attach the four color coded wire lead connections coming from the front underside of the Tone Arm onto the rear of the McIntosh Moving Coil Cartridge as follows. Refer to figures 4, 5, 6 and 8.

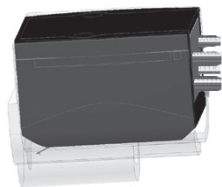

Figure 4

### Rear View of McIntosh MCC10 Cartridge

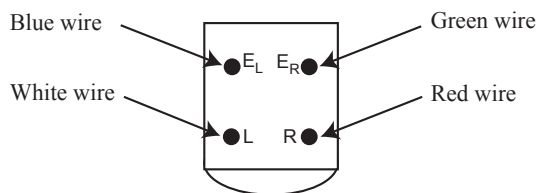

Figure 5

Cartridge Pin Identification	Wire Color
E <sub>R</sub>	Green
R	Red
E <sub>L</sub>	Blue
L	White

- Locate in the Hardware Package two M2.5 x 4.5mm mounting screws.
- Position the Cartridge up to the underside of the Tone Arm Headshell, with the top rear edge of the Cartridge parallel to and touching the molded ridge of the Headshell. Refer to figures 7 and 8.

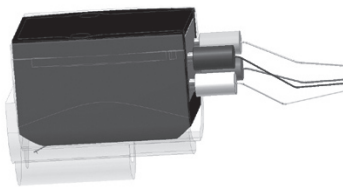

Figure 6

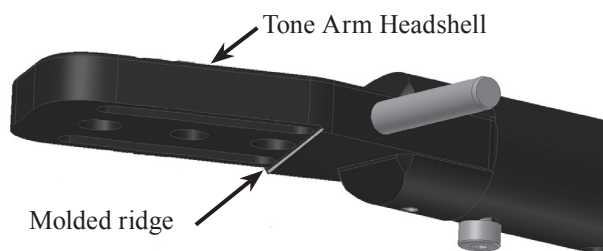

Figure 7

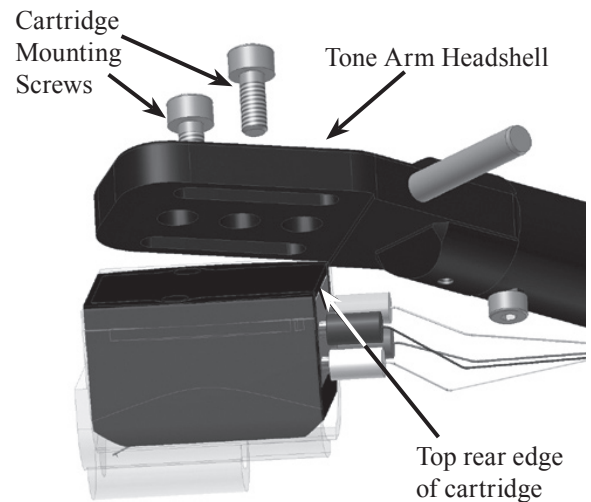

Figure 8

- Insert the two screws (from step 2) through the top of the headshell and into the Cartridge Body and fasten them with a small screwdriver. Make sure the sides of the Cartridge are parallel to sides of the Tone Arm Headshell before tightening the screws. Refer to figure 9.



Figure 9

- Remove any shipping restraining materials from the Tone Arm Rest Holder. Refer to figure 10.

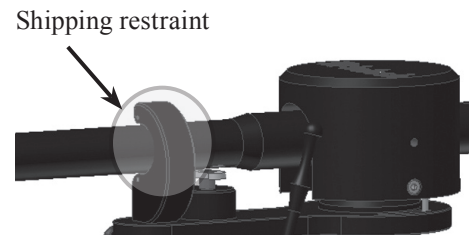

Figure 10

- Remove the foil tape from the Tone Arm Support Arm to free the Anti-Skate Cord. Refer to figure 11.

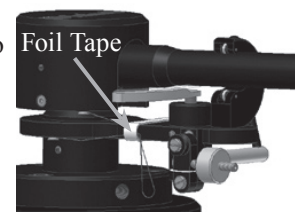

Figure 11

- Position the Anti-Skate Cord over the Anti-Skate Pulley. Refer to figure 12. Carefully remove the Red Color "O" Ring from the shaft of the Anti-Skate Weight

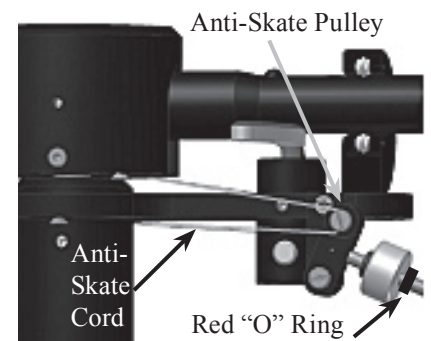

Figure 12

- Locate the Tone Arm Counter Weight. Loosen up the knurled knob to permit installing the counter weight onto the rear of the Tone Arm. Position the Counter Weight on the Tone Arm so the front surface of the Counter Weight lines



up with the McIntosh MCC10 Cartridge position marking on the surface. Refer to figure 13.

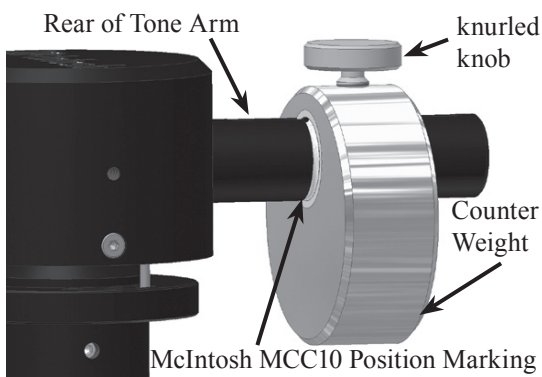

Figure 13

Then tighten the knurled knob to secure the position of the Counter Weight.

9. Locate the Tone Arm Height Gauge (used for the McIntosh MCC10 Cartridge) from inside the accessory box.

10. The gauge should just fit between the Tone Arm Housing and the Mounting Plate of the Tone Arm. This will verify the preset Tone

MCC10 Height Gauge

Arm Height has not changed during shipping. Refer to figure 14. If the space has changed, carefully loosen the Tone Arm Height Set Screw in the Mounting Plate and adjust the height of the Tone Arm so the gauge will just fit.

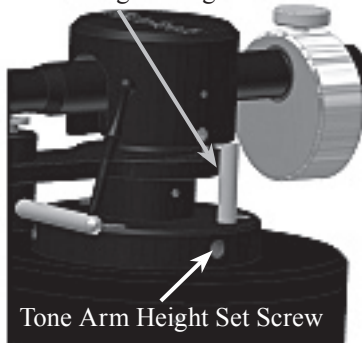

Figure 14

*Note: Do not rotate the Tone Arm Horizontally when making the vertical height adjustment.*

11. Place the McIntosh MT10 Turntable in its operation location.

*Notes: 1. To reduce the chance of acoustic feedback locate the turntable the greatest possible distance from the system loudspeakers.*

*2. To minimize the possibility of the cartridge stylus jumping record grooves, place the turntable on a mechanically stable surface such as wall shelving anchored to wall studs.*

12. Remove the protective film from the Optical Sensor located on the Turntable Top Surface. Refer to figure 15.

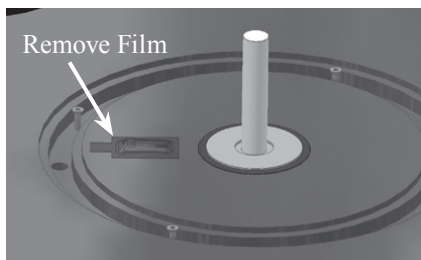

Figure 15

13. Remove the protective film from the bottom of the Turntable Platter cover the Optical Ring. Refer to figure 16.

14. Remove the protective foil from the bottom of the Turntable Vertical Bearing opening. Refer to figure 17.

15. Locate the supplied Turntable Bearing Oil and place two small drops of Oil on the top sides of the Vertical Bearing Ceramic Shaft.

16. Very carefully center the Vertical Bearing Ceramic Shaft with the Vertical Bearing opening on the bottom of the Turntable Platter. Lower the Platter onto the Ceramic Shaft while keeping the platter parallel with the top surface of the Turntable. Refer to figures 18, 19 and 20.

17. Using the supplied cloth gloves place the belt onto the circumference of the platter and then onto the pulley of the motor. Rotate the platter by hand while seating the belt into the recessed groove on the platter.

18. Locate the Turntable Platter Mat and place it on top of the platter.

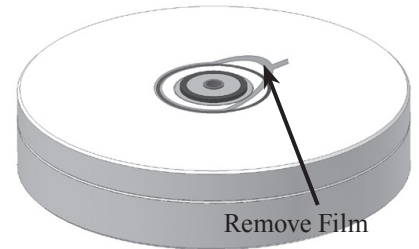

Figure 16



Figure 17

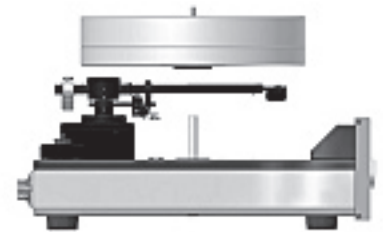

Figure 18



Figure 19

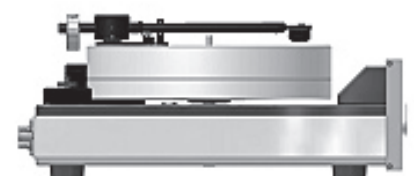

Figure 20

## Assembling the Turntable, con't

19. Locate the McIntosh Bubble Level and place it on the Turntable Platter Mat. If the Bubble is not in the center circle of the Bubble

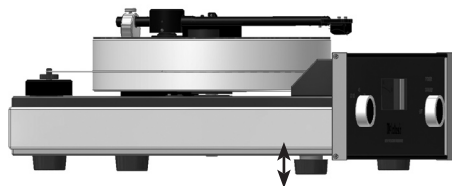
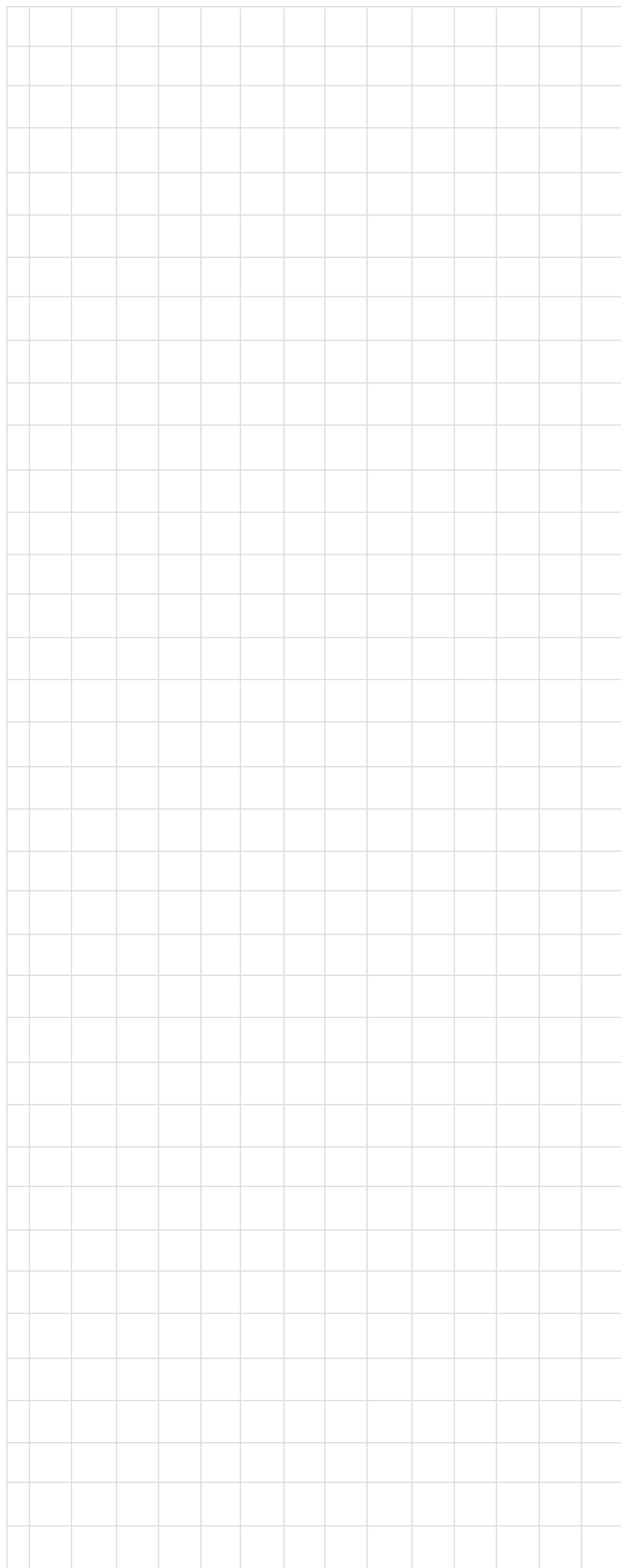

Figure 21

- Level adjust the height the Turntable Feet (by rotating them clockwise or counter clockwise) until it is level. Refer to figure 21.
20. Carefully slide off the clear protective cover from the cartridge by pulling the cover straight toward you.
21. Proceed to Rear Panel Connections.



AUDIO OUTPUTS connect to MC (Moving Coil) Inputs of the Preamplifier or A/V Control Center when the McIntosh MCCI0 Cartridge is installed. Contact your McIntosh Dealer for additional assistance.

GND (Ground) connects to GND (Ground) connection on the Preamplifier or A/V Control Center

Connect to the external Power Supply supplied with the MT10 Turntable. Then connect the Power Supply to a live AC outlet. Refer to information on the Power Supply to determine the correct voltage

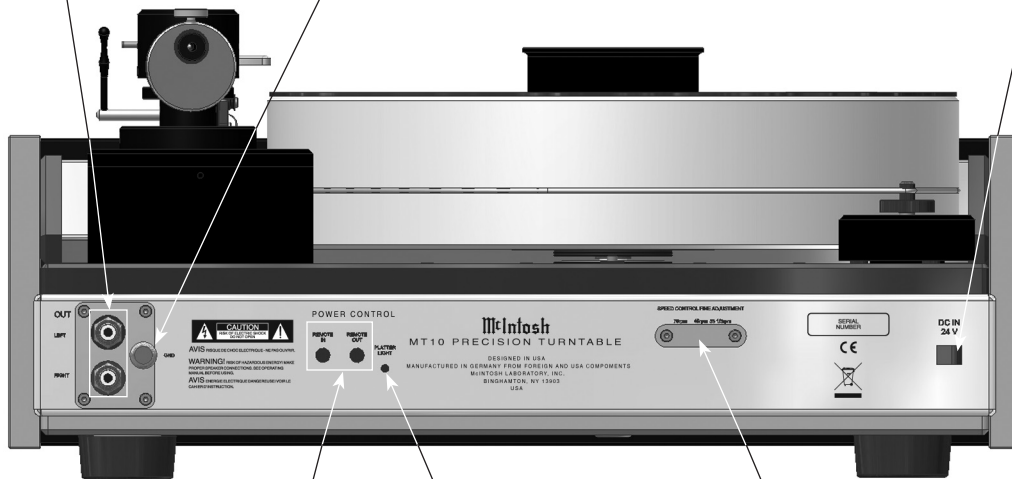

POWER CONTROL REMOTE IN receives turn-on signals from a McIntosh component and switches the Front Panel Illumination On/Off. POWER CONTROL REMOTE OUT sends turn-on signals on to another McIntosh Component

PLATTER LIGHT Fine adjustment of the Turntable Platter Illumination level

Fine speed adjustments for 33-1/3, 45 and 78 rpm. These Adjustments require special test records and precision measurement equipment to accurately set the speeds. Contact your McIntosh Dealer for assistance.

## How to Connect the Turntable

1. Connect a Power Control Cable from the MT10 POWER CONTROL REMOTE IN to the POWER CONTROL ACC Output jack of a McIntosh Preamplifier or A/V Control Center.
2. Optionally, connect a Power Control Cable from the MT10 POWER CONTROL REMOTE OUT to the POWER CONTROL IN jack of a McIntosh source component.
3. Connect a wire from the MT10 GND (Ground) Post to the GND (Ground) post on the McIntosh Preamplifier or A/V Control Center.
4. Connect Audio Cables from the MT10 OUT L and R jacks to the MC Inputs on a McIntosh Preamplifier or

A/V Control Center.

*Note: The MCC10 is a high output Moving Coil Cartridge and is supplied with the MT10 Turntable. When connected to a Phono Input (MM [Moving Magnet]) on a Preamplifier or A/V Control Center, it should produce satisfactory volume level. If additional volume level is desired, an in-line Pre-Preamplifier or step up transformer may be added. Contact your McIntosh Dealer for additional information and assistance.*

5. Connect the supplied external Power Supply to the MT10 DC IN 24V socket and the Power Supply to a live AC outlet.

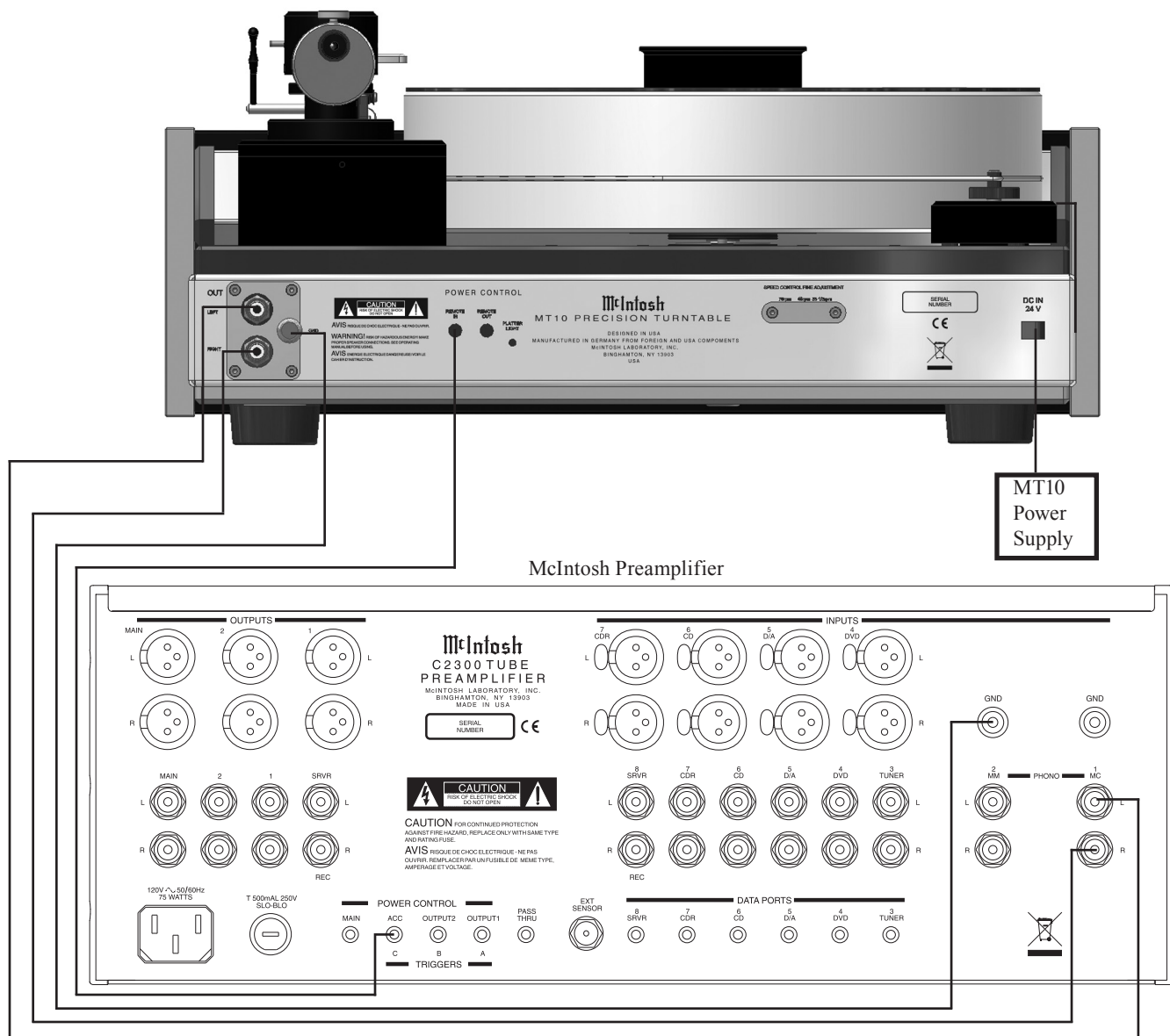

## Front Panel Display, Switches, Lever and Record Clamp

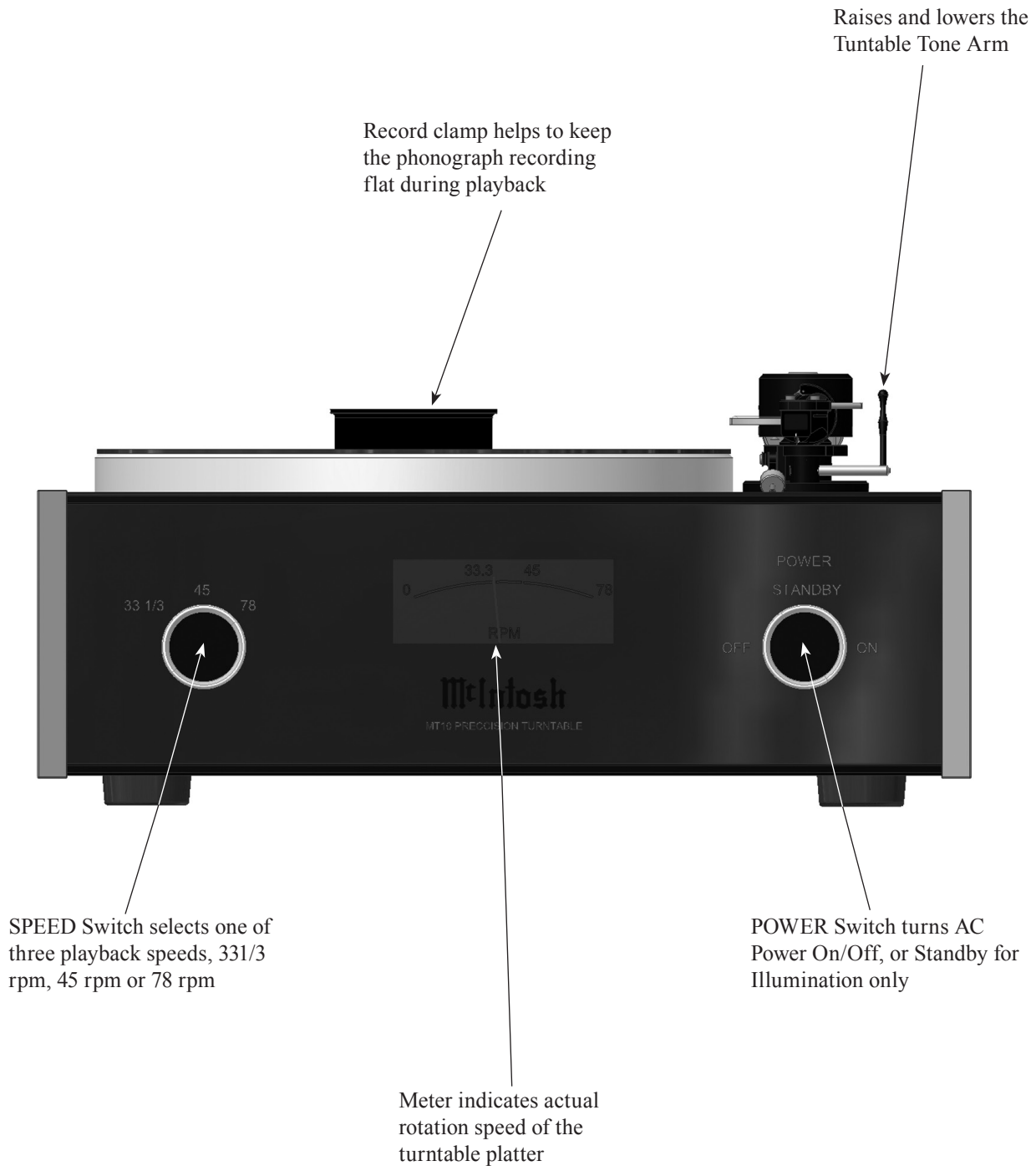

## How to Operate the Turntable

### Power Selection

Rotate the POWER Switch to select the Turntable operation mode you desire. Refer to figure 50.

**Power Off** - The Front Panel and Turntable Platter lights are turned Off. There is no Turntable Platter rotation.

**Standby** - The Front Panel and Turntable Platter will illuminate when the McIntosh Preamplifier or A/V Control Center is turned On. There is no Turntable Platter rotation.

*Note: There must be a power control connection between the MT10 and the McIntosh Preamplifier or A/V Control Center, in order for the Standby Mode to function.*

**On** - The Front Panel and Turntable Platter lights are turned On. The Turntable Platter will rotate at the selected speed.

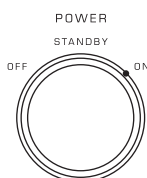

Figure 50

### Speed Selection

Rotate the SPEED Switch to select the playback speed (33-1/3 rpm, 45 rpm or 78 rpm) of the phonograph record to be played. Refer to figure 51.

The Front Panel Platter Speed Meter indicates the actual speed of the Turntable Platter during playback of the recording. Refer to figure 52.

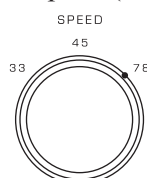

Figure 51

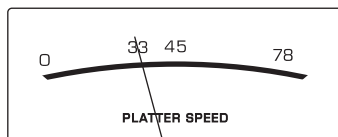

Figure 52

### Tone Arm Lift

The McIntosh MT10 Precision Turntable has a built-in manual Tone Arm Lift Mechanism for safe placement and removal of the cartridge stylus on the photograph record.

Perform the following steps:

1. Push on the top part of the Tone Arm Lift Lever towards the rear of the turntable. Refer to figure 53.

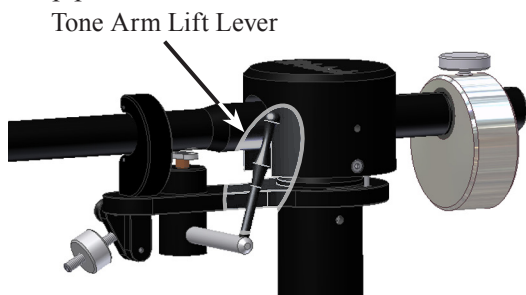

Figure 53

2. Release the Tone Arm from the Tone Arm Holder. Refer to figure 54.

3. Position the Tone Arm over the desired spot of the Photograph record.

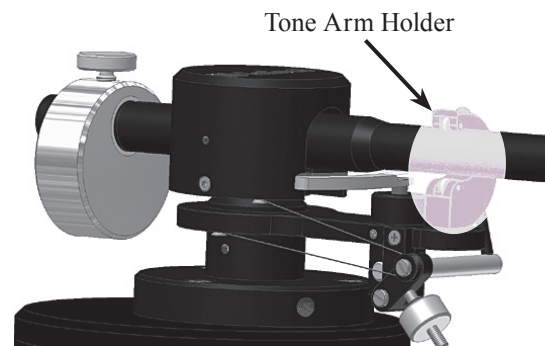
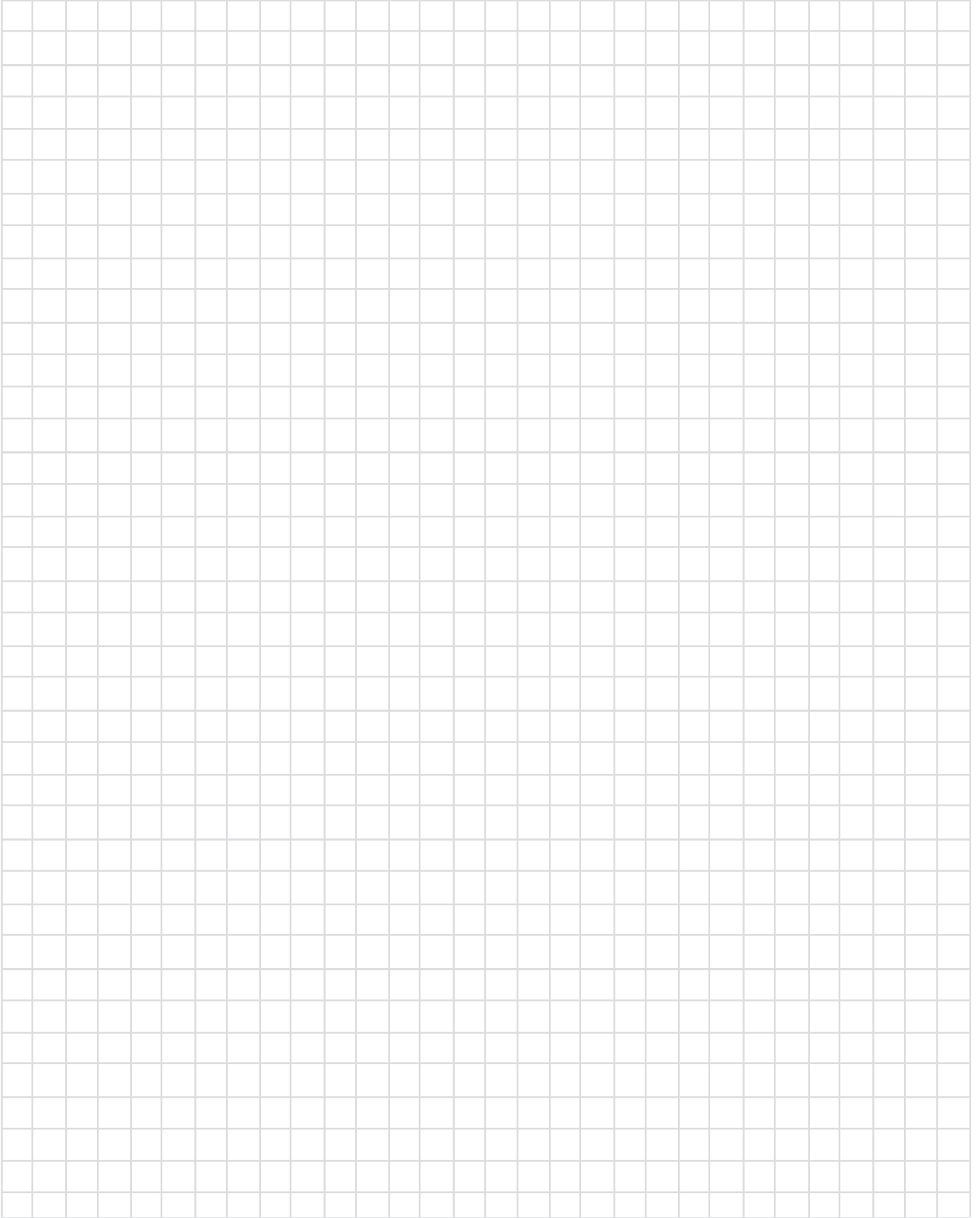
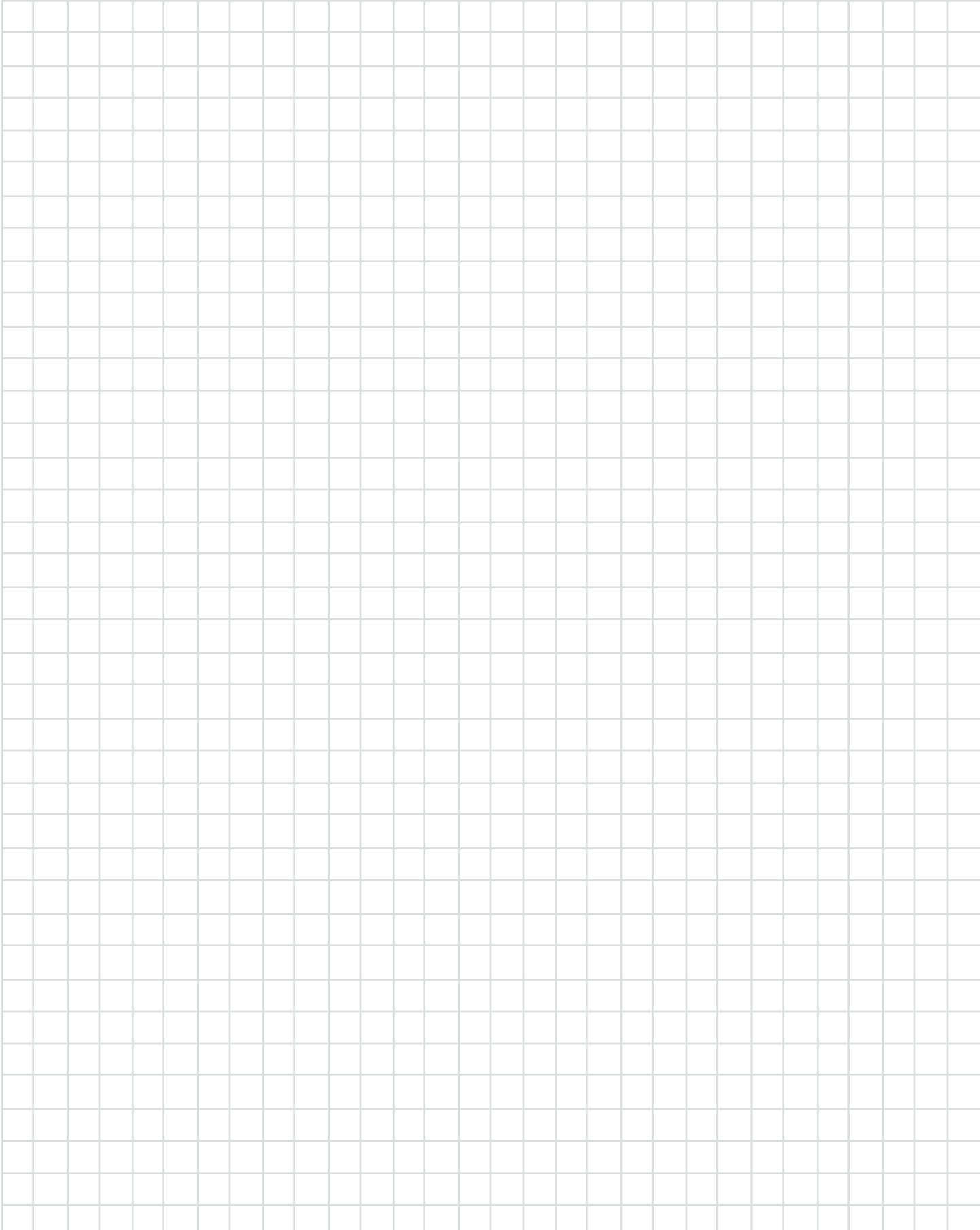

Figure 54

4. Pull on the top part of the Tone Arm Lift Lever towards the front of the turntable to begin playback.







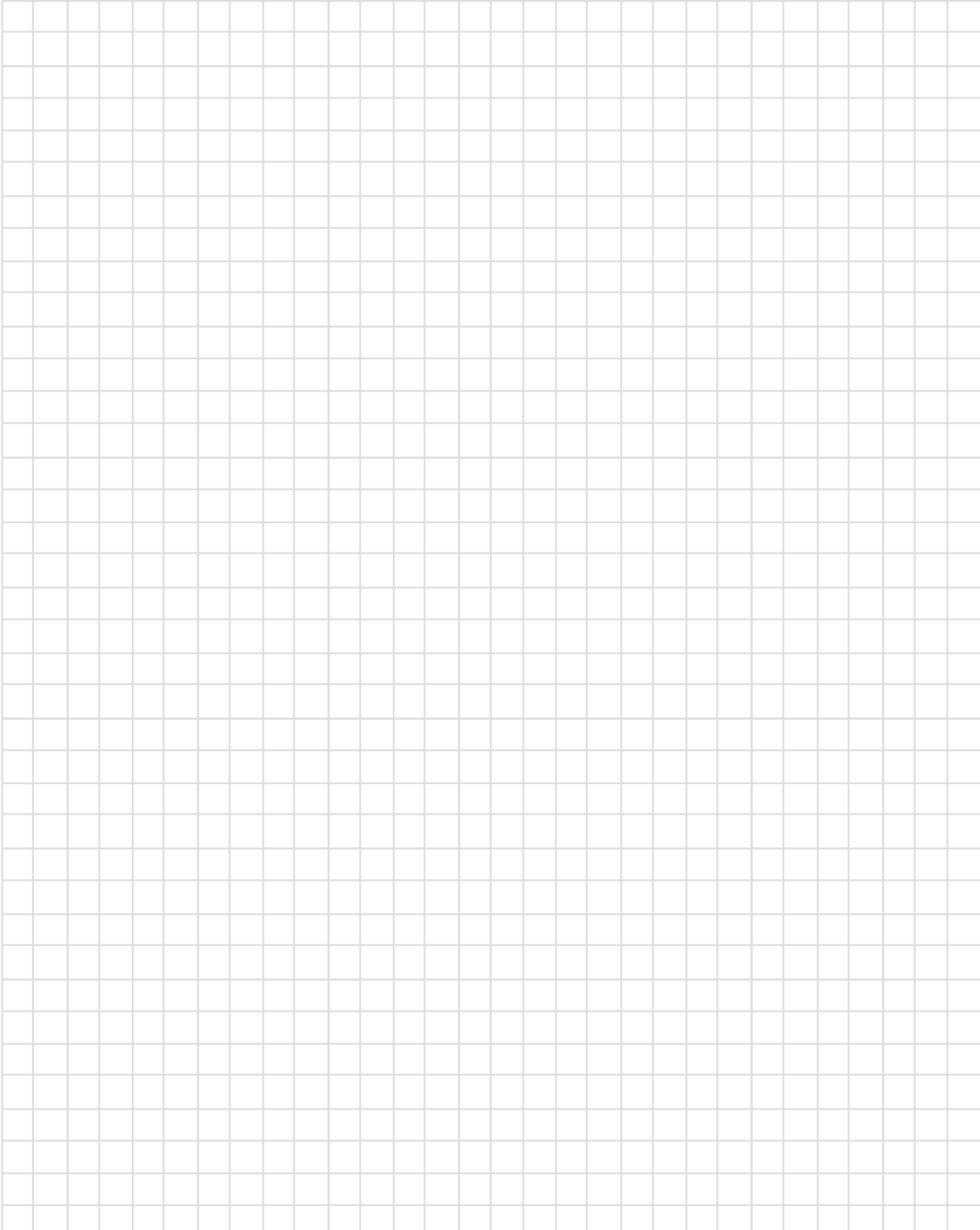



---

## MCC10 Cartridge Specifications

---

### Output Level

0.5 mV at 5 cm/s

### Load Impedance

Greater than 200 ohms, 500 ohms recommended

### Frequency Response

20Hz to 50,000Hz

### Compliance

$6 \times 10^{-6}$  cm/dyne

### Recommended Tracking Force

2.4 g

### Channel Difference

Less than 0.3 dB

### Total Mass

11 g

### Stylus

Elliptical Diamond

### Cantilever Material

Aluminum

### Coil Assembly

Symmetric design

### Body

Ebony wood tone

---

## MT10 Turntable Specifications

---

### Playback Speeds

33-1/3 rpm, 45 rpm and 78rpm

### Motor Type

DC Brushless

---

## MT10 External Power Supply Specifications

---

### Output Voltage

24 Volts, 625ma

### Power Requirement

100 Volts, 50/60Hz at 400ma

110 Volts, 50/60Hz at 400ma

120 Volts, 50/60Hz at 400ma

220 Volts, 50/60Hz at 400ma

230 Volts, 50/60Hz at 400ma

240 Volts, 50/60Hz at 400ma

---

## General Specifications

---

### Overall Dimensions

Width is 17-1/2 inches (44.45cm)

Height is 8-13/16 inches (22.38cm)

Depth is 21 inches (53.34cm)

*Note: Tone Arm Height will vary depending on type of Cartridge installed.*

**Packing Instructions**

In the event it is necessary to repack the equipment for shipment, the equipment must be packed exactly as shown below. It is very important the four feet are still attached to the bottom of the equipment. This will ensure the proper equipment location on the bottom pad. Failure to do this will result in shipping damage.

Use the original shipping carton and interior parts only if they are all in good serviceable condition. If a shipping carton or any of the interior part(s) are needed, please call or write Customer Service Department of McIntosh Laboratory. Refer to page 3. Please see the Part List for the correct part numbers.

Quantity	Part Number	Description
1	034420	Outer shipping carton only
1	034424	Turntable Platter/Accessories Inner carton only
2	034425	Top and bottom foam pad
1	034426	Center foam pad
1	034427	Accessory box
1	034421	Turntable Inner carton only
1	034422	Turntable Top foam pad
1	034419	Bottom locating pad
2	034423	End caps

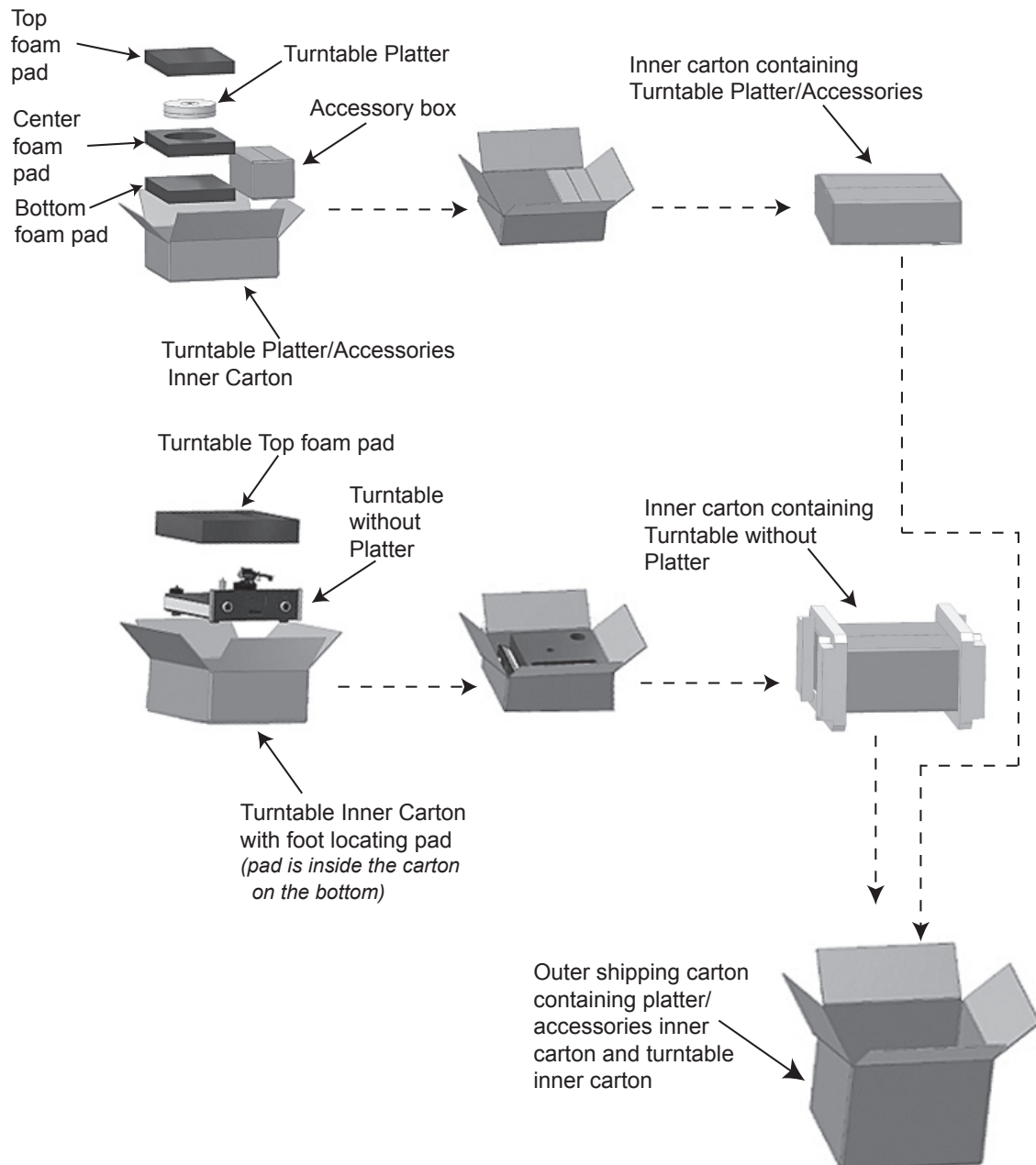



McIntosh Laboratory, Inc.  
2 Chambers Street  
Binghamton, NY 13903

The continuous improvement of its products is the policy of McIntosh Laboratory Incorporated who reserve the right to improve design without notice. Printed in the U.S.A.

McIntosh Part No. 04106300

## Free Manuals Download Website

<http://myh66.com>

<http://usermanuals.us>

<http://www.somanuals.com>

<http://www.4manuals.cc>

<http://www.manual-lib.com>

<http://www.404manual.com>

<http://www.luxmanual.com>

<http://aubethermostatmanual.com>

Golf course search by state

<http://golfingnear.com>

Email search by domain

<http://emailbydomain.com>

Auto manuals search

<http://auto.somanuals.com>

TV manuals search

<http://tv.somanuals.com>