

# OPERATION MANUAL



## DRY PRIME PUMP

MP150SDLTE (6-inch, High Flow, Deutz F3L914, Electric Brakes)  
MP150SDLTS (6-inch, High Flow, Deutz F3L914, Surge Brakes)  
MP150SDLSM (6-inch, High Flow, Deutz F3L914, Skid Mount)  
MP200DLTE (8-inch, High Flow, Deutz F3L914, Electric Brakes)  
MP200DLTS (8-inch, High Flow, Deutz F3L914, Surge Brakes)  
MP200DLSM (8-inch, High Flow, Deutz F3L914, Skid Mount)  
MP200SDLTE (8-inch, High Flow, Deutz F4L914, Electric Brakes)  
MP200DLST (8-inch, High Flow, Deutz F4L914, Surge Brakes)  
MP200SDLSM (8-inch, High Flow, Deutz F4L914, Skid Mount)

Revision #3 (10/06/08)

To find the latest revision of this  
publication, visit our website at:  
[www.multiquip.com](http://www.multiquip.com)



**THIS MANUAL MUST ACCOMPANY THE EQUIPMENT AT ALL TIMES.**

**P/N 17567**



**WARNING**



**CALIFORNIA — Proposition 65 Warning**

Diesel engine exhaust and some of its constituents are known to the State of California to cause cancer, birth defects and other reproductive harm.

### REPORTING SAFETY DEFECTS

If you believe that your vehicle has a defect that could cause a crash or could cause injury or death, you should immediately inform the National Highway Traffic Safety Administration (NHTSA) in addition to notifying Multiquip at 1-800-421-1244.

If NHTSA receives similar complaints, it may open an investigation, and if it finds that a safety defect exists in a group of vehicles, it may order a recall and remedy campaign. However, NHTSA cannot become involved in individual problems between you, your dealer, or Multiquip.

To contact NHTSA, you may either call the Vehicle Safety Hotline toll-free at 1-888-327-4236 (TTY: 1-800-424-9153), go to <http://www.nhtsa.dot.gov>; or write to:

Administrator  
NHTSA  
1200 New Jersey Avenue S.E.  
Washington, DC 20590

You can also obtain information about motor vehicle safety from <http://www.safecar.gov>.

# TRAINING CHECKLIST

## TRAINING CHECKLIST

This checklist will lists some of the minimum requirements for machine maintenance and operation. Please feel free to detach it and make copies. Use this checklist whenever a new operator is to be trained or it can be used as a review for more experienced operator's.

| TRAINING CHECKLIST |  |     |      |
|--------------------|--|-----|------|
| NO.                | DESCRIPTION  | OK? | DATE |
| 1                  | Read Operator's Manual completely.   |     |      |
| 2                  | Machine layout, location of components, checking of engine and oil levels. |     |      |
| 3                  | Fuel system, refueling procedure.  |     |      |
| 4                  | Pump priming procedure.  |     |      |
| 5                  | Emergency stop procedures.   |     |      |
| 6                  | Engine start-up procedure.   |     |      |
| 7                  | Lifting of machine (lifting bail)  |     |      |
| 8                  | Pump applications (lift, uses etc.)  |     |      |
| 9                  | Suction strainer placement.  |     |      |
| 10                 | Hose connections.  |     |      |
| 11                 | Pump placement.  |     |      |
| 12                 | Trailer safety guidelines.   |     |      |
| 13                 | Protective clothing guidelines.  |     |      |
| 14                 | Vacuum test procedure.   |     |      |
| 15                 | Machine transport and storage.   |     |      |
| 16                 | Clean out pump cavity procedure.   |     |      |

Operator \_\_\_\_\_ Trainee \_\_\_\_\_

COMMENTS:

# DAILY PRE-OPERATION CHECKLIST

## DAILY PRE-OPERATION CHECKLIST

| DAILY PRE-OPERATION CHECKLIST |  |
|-------------------------------|--|
| 1                             | Check engine oil level.                          |
| 2                             | Check fuel level (and for clean fuel).           |
| 3                             | Check cooling fins and cooling air flow.         |
| 4                             | Check engine air cleaner.                        |
| 5                             | Check engine battery and cable connections.      |
| 6                             | Check pump interior (impeller and volute).       |
| 7                             | Check vacuum pump seal oil.                      |
| 8                             | Check bearing housing oil.                       |
| 9                             | Check pump seal.                                 |
| 10                            | Check pump casing for cracks.                    |
| 11                            | Check trailer wheel lug nuts for tightness.      |
| 12                            | Check trailer wheel bearings.                    |
| 13                            | Check trailer hitch and ball.                    |
| 14                            | Check trailer springs and hardware (jack stand). |
| 15                            | Check trailer tire pressure.                     |
| 16                            | Check trailer lights.                            |

COMMENTS:

## Multiquip Dry Prime Diesel Powered Trash Pump

|  |       |
|--|-------|
| California Proposition 65 Warning .....    | 2     |
| Reporting Safety Defects .....             | 3     |
| Training Checklist .....                   | 4     |
| Daily Pre-Operation Checklist .....        | 5     |
| Table Of Contents .....                    | 6     |
| Safety Message Alert Symbols .....         | 8-9   |
| Rules For Safe Operation .....             | 10-12 |
| Pump Dimensions .....                      | 13    |
| Trailer Dimensions .....                   | 14    |
| Pump Specifications .....                  | 15    |
| Engine Specifications .....                | 16    |
| General Information .....                  | 17    |
| Pump Components .....                      | 18-19 |
| Engine Components .....                    | 20    |
| Engine Control Box Components .....        | 21    |
| Pumping Application .....                  | 22    |
| Towing Application .....                   | 23    |
| Setup .....                                | 24    |
| Setup .....                                | 25    |
| Operation .....                            | 26-27 |
| Maintenance (Pump) .....                   | 28    |
| Maintenance (Engine) .....                 | 29-30 |
| Maintenance (Trailer) .....                | 31-34 |
| Trailer Safety Guidelines .....            | 35-44 |
| Tire Safety .....                          | 45-50 |
| Trailer Lights Wiring Diagram .....        | 51    |
| Nameplate and Decals .....                 | 52    |
| Troubleshooting (Pump) .....               | 53    |
| Troubleshooting (Engine) .....             | 54-55 |
| Trailer Brakes (Hydraulic) .....           | 56    |
| Trailer Brakes (Electric) .....            | 56    |
| Terms and Conditions Of Sale — Parts ..... | 57    |

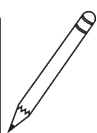
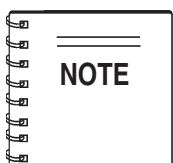

***Specification and part number are subject to change without notice.***



# SAFETY MESSAGE ALERT SYMBOLS

## FOR YOUR SAFETY AND THE SAFETY OF OTHERS!

Safety precautions should be followed at all times when operating this equipment. Failure to read and understand the Safety Messages and Operating Instructions could result in injury to yourself and others.

### NOTE

This Owner's Manual has been developed to provide complete instructions for the safe and efficient operation of the Multiquip Model **Dry Prime Pump**. Refer to the engine manufacturer's instructions for data relative to its safe operation.

**Before using this trash pump, ensure that the operating individual has read and understood all instructions in this manual.**

## SAFETY MESSAGE ALERT SYMBOLS

The three (3) Safety Messages shown below will inform you about potential hazards that could injure you or others. The Safety Messages specifically address the level of exposure to the operator, and are preceded by one of three words: **DANGER**, **WARNING**, or **CAUTION**.

### **DANGER**

You **WILL** be **KILLED** or **SERIOUSLY** injured if you **DO NOT** follow directions.

### **WARNING**

You **CAN** be **KILLED** or **SERIOUSLY** injured if you **DO NOT** follow directions.

### **CAUTION**

You **CAN** be **INJURED** if you **DO NOT** follow directions.

Potential hazards associated with the **Dry Prime Trash Pump** operation will be referenced with Hazard Symbols which appear throughout this manual, and will be referenced in conjunction with Safety Message Alert Symbols.

## HAZARD SYMBOLS

### **Lethal Exhaust Gases**



Engine exhaust gases contain poisonous carbon monoxide. This gas is colorless and odorless, and can cause death if inhaled. **NEVER** operate this equipment in a confined area or enclosed structure that does not provide ample free flow air.

### **Explosive Fuel**

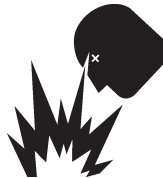

**DIESEL** fuel is extremely flammable, and its vapors can cause an explosion if ignited. **DO NOT** start the engine near spilled fuel or combustible fluids. **DO NOT** fill the fuel tank while the engine is running or hot. **DO NOT** overfill tank, since spilled fuel could ignite if it comes into contact with hot engine parts or sparks from the ignition system. Store fuel in approved containers, in well-ventilated areas and away from sparks and flames. **NEVER** use fuel as a cleaning agent.

### **Burn Hazards**



Engine components can generate extreme heat. To prevent burns, **DO NOT** touch these areas while the engine is running or immediately after operations. Never operate the engine with heat shields or heat guards removed.

### **Rotating Parts**



**NEVER** operate equipment with covers, or guards removed. Keep fingers, hands, hair and clothing away from all moving parts to prevent injury.



# SAFETY MESSAGE ALERT SYMBOLS



## Accidental Starting



OFF

**ALWAYS** place the engine ON/OFF switch in the **OFF** position. Close the vandal cover door on the engine control box. Lock the door by placing a pad lock on the door hasp when the machine is not in use.



## Respiratory Hazard



**ALWAYS** wear approved respiratory protection.



## Sight and Hearing Hazard

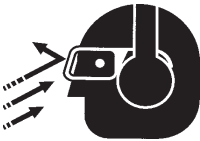

**ALWAYS** wear approved eye and hearing protection.



## Equipment Damage Messages

Other important messages are provided throughout this manual to help prevent damage to your pump, other property, or the surrounding environment.

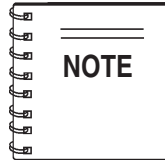

This pump, other property, or the surrounding environment could be damaged if you do not follow instructions.

# RULES FOR SAFE OPERATION



## DANGER

Read this manual!

Failure to follow instructions in this manual may lead to serious injury or even death! This equipment is to be operated by trained and qualified personnel only! This equipment is for industrial use only.

The following safety guidelines should always be used when operating the **Dry Prime Pump**:

### GENERAL SAFETY

■ **DO NOT** operate or service this equipment before reading this entire manual.



■ This equipment should not be operated by persons under 18 years of age.

■ **NEVER** operate this equipment without proper protective clothing, shatterproof glasses, steel-toed boots and other protective devices required by the job.



■ **NEVER** operate this equipment when not feeling well due to fatigue, illness or taking medicine.



■ **NEVER** operate this equipment under the influence of **drugs** or **alcohol**.



■ **ALWAYS** wear proper respiratory (mask), hearing and eye protection equipment when operating the pump.

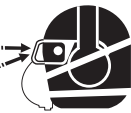

■ Whenever necessary, replace nameplate, operation and safety decals when they become difficult read.

■ Manufacture does not assume responsibility for any accident due to equipment modifications.

■ **NEVER** use accessories or attachments, which are not recommended by Multiquip for this equipment. Damage to the equipment and/or injury to user may result.

■ **NEVER** touch the hot exhaust manifold, muffler or cylinder. Allow these parts to cool before servicing engine or pump.



■ **High Temperatures** – Allow the engine to cool before adding fuel or performing service and maintenance functions. Contact with **hot!** components can cause serious burns.

■ The air-cooled diesel engine of this pump requires an adequate free flow of cooling air. **NEVER** operate the pump in any enclosed or narrow area where free flow of the air is restricted. If the air flow is restricted it will cause serious damage to the pump or engine and may cause injury to people. Remember the engine gives off **DEADLY** carbon monoxide gas.

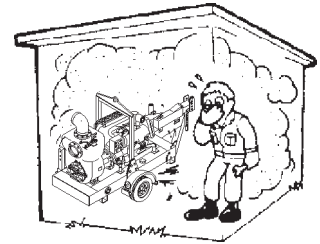

■ **ALWAYS** refuel in a well-ventilated area, away from sparks and open flames.

■ **ALWAYS** use extreme caution when working with **flammable** liquids. When refueling, **stop the engine** and allow it to cool. **DO NOT smoke** around or near the machine. Fire or explosion could result from fuel vapors, or if fuel is spilled on a hot engine.



■ **NEVER** operate the pump in an explosive atmosphere or near combustible materials. An explosion or fire could result causing severe **bodily harm or even death**.

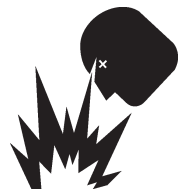

■ Topping-off to filler port is dangerous, as it tends to spill fuel.

■ Stop the engine when leaving the pump unattended.

■ Block the unit when leaving or when using on a slope.

# RULES FOR SAFE OPERATION

- **NEVER** pump volatile, flammable or low flash point fluids. These fluids could ignite or explode.
- **NEVER** pump corrosive chemicals or water containing toxic substances. These fluids could create serious health and environmental hazards. Contact local authorities for assistance.
- **NEVER** open the volute cover during operation or start the pump with the cover off. The rotating impeller inside the pump can cut or sever objects caught in it.
- **NEVER** block or restrict flow from discharge hose. Remove kinks from discharge line before starting pump. Operation with a blocked discharge line can cause water inside pump to overheat.
- **NEVER** run engine without air cleaner. Severe engine damage may occur.
- **ALWAYS** read, understand, and follow procedures in Operator's Manual before attempting to operate equipment.
- **ALWAYS** be sure the operator is familiar with proper safety precautions and operations techniques before using pump.
- **ALWAYS** store equipment properly when it is not being used. Equipment should be stored in a clean, dry location out of the reach of children.
- Refer to the *Engine Owner's Manual* for engine technical questions or information.
- In winter, drain water from pump housing to prevent freezing.
- **ALWAYS** make sure pump is correctly secured to the trailer. Check all supports attaching the pump to the trailer and make sure they are tight.
- **ALWAYS** make sure that the pump's trailer is placed on solid level ground so that it cannot slide or shift around, endangering workers. Deploy jack stands for stabilization. Place blocks under the trailer's bumper to make it level (prevents tipping), and use a chocked block underneath the wheels to prevent rolling. Also keep the immediate area free of bystanders.
- **High Temperatures** – Allow the engine to cool before adding fuel or performing service and maintenance functions. Contact with *hot* components can cause serious burns.

## Maintenance Safety

- **NEVER** lubricate components or attempt service on a running machine.
- **ALWAYS** allow the machine a proper amount of time to cool before servicing.
- Keep the machinery in proper running condition.
- Fix damage to the machine immediately and always replace broken parts.
- Dispose of hazardous waste properly. Examples of potentially hazardous waste are used motor oil, fuel and fuel filters.
- **DO NOT** use food or plastic containers to dispose of hazardous waste.
- **DO NOT** pour waste, oil or fuel directly onto the ground, down a drain or into any water source.

## Lifting

- The pump has an operating weight of 3180 lbs. (1,442 kg) or more. Use lifting equipment with a rated capacity of at least 14,000 lbs. (6,350 kg). Remove suction & discharge hoses/pipes before lifting.

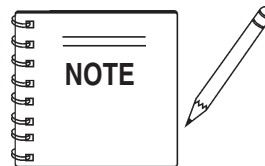

Add 1000 lbs. (454 kg.) to the operating weight for a full tank of fuel, 140 gallons (530 liters).

## EMERGENCIES

- **ALWAYS** know the location of the nearest *fire extinguisher* and *first aid kit*.



- In emergencies *always* know the location of the nearest phone or *keep a phone on the job site*. Also know the phone numbers of the nearest *ambulance*, *doctor* and *fire department*. This information will be invaluable in the case of an emergency.



## Battery

The battery contains acids that can cause injury to the eyes and skin. To avoid eye irritation, **always** wear safety glasses or face shielding. Use well-insulated gloves when picking up the battery. Use the following guidelines when handling the battery.

- **DO NOT** drop the battery. Any impact to the battery may cause it to explode.
- **DO NOT** expose the battery to open flames, sparks, lit cigarettes etc. The battery contains combustible gases and liquids. If these gases and liquids come in contact with a flame or spark an explosion can occur.
- **ALWAYS** keep the battery charged. If the battery is not charged, a buildup of combustible gas will occur.
- **ALWAYS** keep battery cables in good working condition. Repair or replace all worn cables.
- **ALWAYS** disconnect the **negative battery terminal** before performing service on the equipment.
- Inadequate battery connections may cause poor starting of the trowel, and create other malfunctions.
- **ALWAYS** recharge the battery in a vented air environment to avoid risk of a dangerous concentration of combustible gases.
- **DO NOT** charge battery if frozen. Battery can explode. When frozen, warm battery to at least 61°F (16°C).
- If the battery liquid (dilute sulfuric acid) comes in contact with **clothing or skin**, rinse skin or clothing immediately with plenty of water.
- If the battery liquid (dilute sulfuric acid) comes in contact with your **eyes**, rinse eyes immediately with plenty of water, then contact the nearest doctor or hospital and seek medical attention.

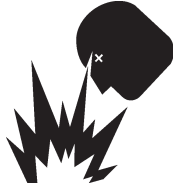

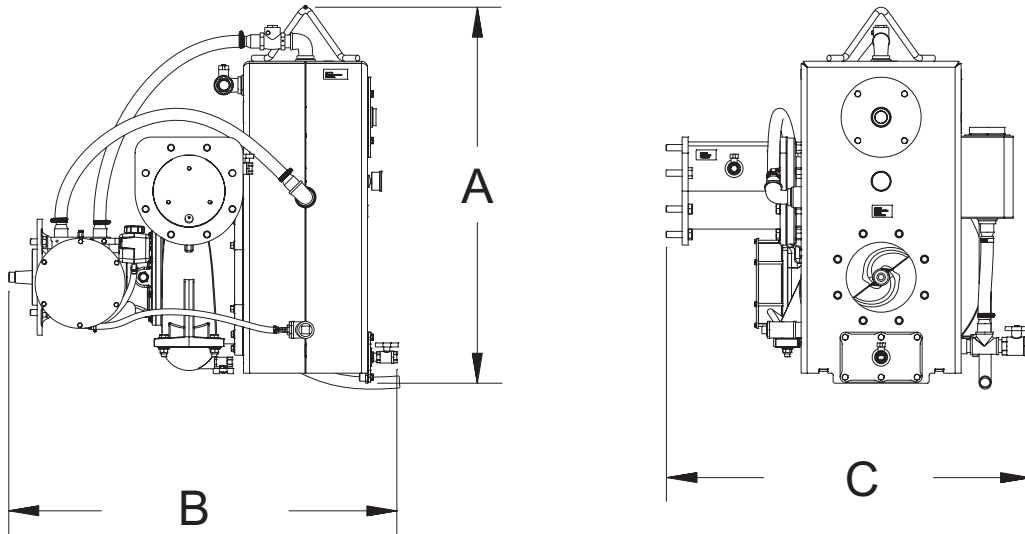

**Figure 1. Pump Dimensions**

| TABLE 3. PUMP DIMENSIONS |             |                          |
|--------------------------|-------------|--------------------------|
| REFERENCE LETTER         | DESCRIPTION | DIMENSIONS INCHES (MM)   |
| A                        | HEIGHT      | 47 INCHES (1193.8 MM)    |
| B                        | WIDTH       | 48.5 INCHES (1231.97 MM) |
| C                        | DEPTH       | 45.6 INCHES (1158.14 MM) |

# TRAILER DIMENSIONS

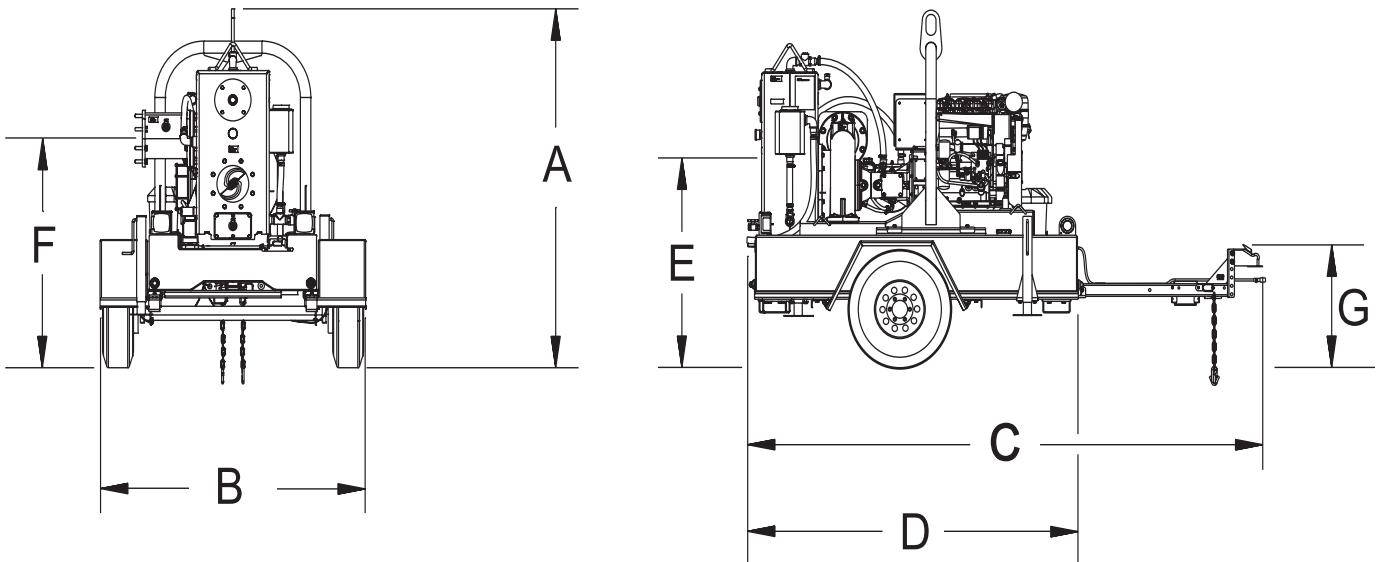

Figure 2. Trailer Dimensions

| TABLE 2. TRAILER DIMENSIONS |                          |                            |
|-----------------------------|--------------------------|----------------------------|
| REFERENCE LETTER            | DESCRIPTION              | DIMENSIONS INCHES (MM)     |
| A                           | HEIGHT                   | 85.53 INCHES (2172.34 MM)  |
| B                           | WIDTH                    | 72.73 INCHES (1847.34 MM)  |
| C                           | LENGTH (Tongue Extended) | 141.56 INCHES (3595.66 MM) |
| D                           | SHIPPING LENGTH          | 94 INCHES (2387.6 MM)      |
| E                           | SUCTION HEIGHT           | TBD                        |
| F                           | DISCHARGE HEIGHT         | TBD                        |
| G                           | HITCH HEIGHT AND RANGE   | TBD                        |

## TABLE 1. PUMP SPECIFICATIONS

| Model                    | MP150SDLSM                             | MP150SDLTE                             | MP150SDLTS                             | MP200DLSM                               | MP200DLTE                               | MP200DLTS                               | MP200SDLSM                              | MP200SDLTE                              | MP200SDLTS                              |
|--------------------------|--|--|--|---|---|---|---|---|---|
| Maximum Pumping Capacity | 2500 GPM<br>(9.4 m <sup>3</sup> /min.) | 2500 GPM<br>(9.4 m <sup>3</sup> /min.) | 2500 GPM<br>(9.4 m <sup>3</sup> /min.) | 2700 GPM<br>(10.2 m <sup>3</sup> /min.) | 2700 GPM<br>(10.2 m <sup>3</sup> /min.) | 2700 GPM<br>(10.2 m <sup>3</sup> /min.) | 3500 GPM<br>(13.2 m <sup>3</sup> /min.) | 3500 GPM<br>(13.2 m <sup>3</sup> /min.) | 3500 GPM<br>(13.2 m <sup>3</sup> /min.) |
| Maximum Suction Lift     | 30 ft.<br>(9.1 meters)                 | 30 ft.<br>(9.1 meters)                 | 30 ft.<br>(9.1 meters)                 | 25 ft.<br>(7.8 meters)                  | 25 ft.<br>(7.8 meters)                  | 25 ft.<br>(7.8 meters)                  | 25 ft.<br>(7.8 meters)                  | 25 ft.<br>(7.8 meters)                  | 25 ft.<br>(7.8 meters)                  |
| Maximum Total Head       | 122 ft.<br>(37 meters)                 | 122 ft.<br>(37 meters)                 | 122 ft.<br>(37 meters)                 | 122 ft.<br>(37 meters)                  | 122 ft.<br>(37 meters)                  | 122 ft.<br>(37 meters)                  | 135 ft.<br>(41 meters)                  | 135 ft.<br>(41 meters)                  | 135 ft.<br>(41 meters)                  |
| Maximum Solids           | 3.2 in.<br>(81.2 mm)                   | 3.2 in.<br>(81.2 mm)                   | 3.2 in.<br>(81.2 mm)                   | 3.2 in.<br>(81.2 mm)                    | 3.2 in.<br>(81.2 mm)                    | 3.2 in.<br>(81.2 mm)                    | 3.6 in.<br>(91.4 mm)                    | 3.6 in.<br>(91.4 mm)                    | 3.6 in.<br>(91.4 mm)                    |
| HP                       | 43 HP<br>(32 kW)                       | 43 HP<br>(32 kW)                       | 43 HP<br>(32 kW)                       | 43 HP<br>(32 kW)                        | 43 HP<br>(32 kW)                        | 43 HP<br>(32 kW)                        | 60 HP<br>(48 kW)                        | 60 HP<br>(48 kW)                        | 60 HP<br>(48 kW)                        |
| RPM                      | 1800 rpm                               | 1800 rpm                               | 1800 rpm                               | 1800 rpm                                | 1800 rpm                                | 1800 rpm                                | 1800 rpm                                | 1800 rpm                                | 1800 rpm                                |
| Sound Pressure           | 74 dBA                                 | 74 dBA                                 | 74 dBA                                 | 74 dBA                                  | 74 dBA                                  | 74 dBA                                  | 76 dBA                                  | 76 dBA                                  | 76 dBA                                  |
| Run Time                 | 56 hours                               | 56 hours                               | 56 hours                               | 56 hours                                | 56 hours                                | 56 hours                                | 41 hours                                | 41 hours                                | 41 hours                                |
| Weight (Skid Mounted)    | 3750 lbs.<br>(1700 kg.)                | 3900 lbs.<br>(1769 kg.)                | 3900 lbs.<br>(1769 kg.)                | 3800 lbs.<br>(1723 kg.)                 | 3950 lbs.<br>(1791 kg.)                 | 3950 lbs.<br>(1791 kg.)                 | 3960 lbs.<br>(1796 kg.)                 | 4110 lbs.<br>(1863 kg.)                 | 4110 lbs.<br>(1863 kg.)                 |
| Air-Cooled Engine        | Deutz<br>F3L914                        | Deutz<br>F3L914                        | Deutz<br>F3L914                        | Deutz<br>F3L914                         | Deutz<br>F3L914                         | Deutz<br>F3L914                         | Deutz<br>F4L914                         | Deutz<br>F4L914                         | Deutz<br>F4L914                         |
| Fuel Capacity            | 125 gal<br>(475 liters)                | 125 gal<br>(475 liters)                | 125 gal<br>(475 liters)                | 125 gal<br>(475 liters)                 | 125 gal<br>(475 liters)                 | 125 gal<br>(475 liters)                 | 125 gal<br>(475 liters)                 | 125 gal<br>(475 liters)                 | 125 gal<br>(475 liters)                 |

### SOUND MEASUREMENTS

The required sound specifications, per Appendix 1, paragraph 1.7.4.f of the EC-Machine Regulations, are defined as follows:

The sound pressure level at the operator's location (L) = 87 dB (A)

The sound power level (L) = 97 dB (A)

These sound values are determined according to ISO 3744 for the sound power level (L) and ISO 6081 for the sound pressure level (L) at the operator's location.

The sound measurements were obtained with the unit operation on pavement at nominal speed.

**TABLE 4. ENGINE SPECIFICATIONS**

|                                  |                          |                          |
|----------------------------------|--------------------------|--------------------------|
| Engine Make                      | Deutz                    | Deutz                    |
| Engine Model                     | F3L914                   | F4L914                   |
| Engine Type                      | Air Cooled               | Air Cooled               |
| Number Of Cylinders              | 3                        | 4                        |
| Bore/Stroke                      | 4/5.2 in<br>102/132 mm   | 4/5.2 in<br>102/132 mm   |
| Displacement                     | 197.5 cu-in<br>(3236 cc) | 263.3 cu-in<br>(4314 cc) |
| Engine HP                        | 40 HP (29.8 kW)          | 52 HP (38.8 kW)          |
| Oil Capacity                     | 2.53 gal (9.6 liters)    | 3.43 gal (13.0 liters)   |
| Fuel Type                        | Diesel                   | Diesel                   |
| Fuel Tank Capacity <sup>1</sup>  | 140 gal (532 liters)     | 140 gal (532 liters)     |
| Weight (Skid Mounted)            | 652.57 lbs.<br>(296 kg)  | 800.28 lbs.<br>(363 kg)  |
| Starting Method                  | Electric Start           | Electric Start           |
| 1) Fuel tank is part of trailer. |                          |                          |



The Multiquip Dry Prime pump is a prime dry and prime-assist pump that can handle dewatering, sewer bypass, and wellpoint applications.

The Dry Prime pump uses a vacuum pump to remove the air. This becomes important in certain applications such as long suction hose runs or multiple suction points (such as wellpoints). In these cases, high volumes of air enters into the pump. Dry Prime uses direct-drive vacuum pump to efficiently remove very large volumes of air quickly to obtain the priming necessary for these special applications. Dry Prime is very useful when you have to move a lot of water fast.

## **Impeller**

The Dry Prime impeller has a patented design to eliminate cavitation. It is a 2-blade spiral, smooth flow, open, non-clog impeller, designed to handle up to 3.2-inch solids. The impeller pulls water directly into the pump from the priming tank, reducing friction losses, and then pushes it out the volute discharge. This design does not cause turbulence normally found in centrifugal pumps.

## **Wear Plate**

In conjunction with the impeller, the wear plate gives a perfect match for great pump performance and durability. The wear plate can be fully adjusted up to .6 inch (15mm) for wear.

## **Priming System**

The vacuum system is innovative, simple, yet rugged and dependable. It uses direct drive which means no belt failure and with only one moving part, means no maintenance. It uses liquid-ring design with a closed water system. Separate oil bath lubrication for the seal and bearings with oil reservoir, can run dry without damage. It operates quietly with no pollution or unwanted discharge noise.

## **Float and Backflush (Priming Tank)**

The priming tank float is a one-piece welded construction, rubber valve seat, self-aligning rubber hinge. This design increases reliability. The backflush valve allows for cleaning of the suction strainer or wellpoint headwhile the engine is running.

## **Fuel Tank Frame and Trackbar System**

Run time is up to 72 hours with the Dry Prime's fuel tank, good for continuous running for those long-term jobs. There are two corner fuel drains to check condition of fuel. The TrackBar system allows for the easy addition of jack stands, fenders, axle, lifting bail, and other options. This allows for fast and easy positioning of the jack stands on the job site to fit the application, or to add subtract jack stands as required. The removable, retractable towing tongue minimizes storage requirements.

## **Volute**

The pump volute has an external inspection cover to inspect or clear the impeller. The pump shaft bearings and mechanical seal are run in independent oil baths for low maintenance.

## **LOFA Engine Control Panel**

Vandal protected panel that provides engine status and shut-downs in the event of low oil pressure, high engine heat, and alternator belt breakage. Optional auto-start module with floats can be added for automatic start-stop of pump engine and pumping operation.

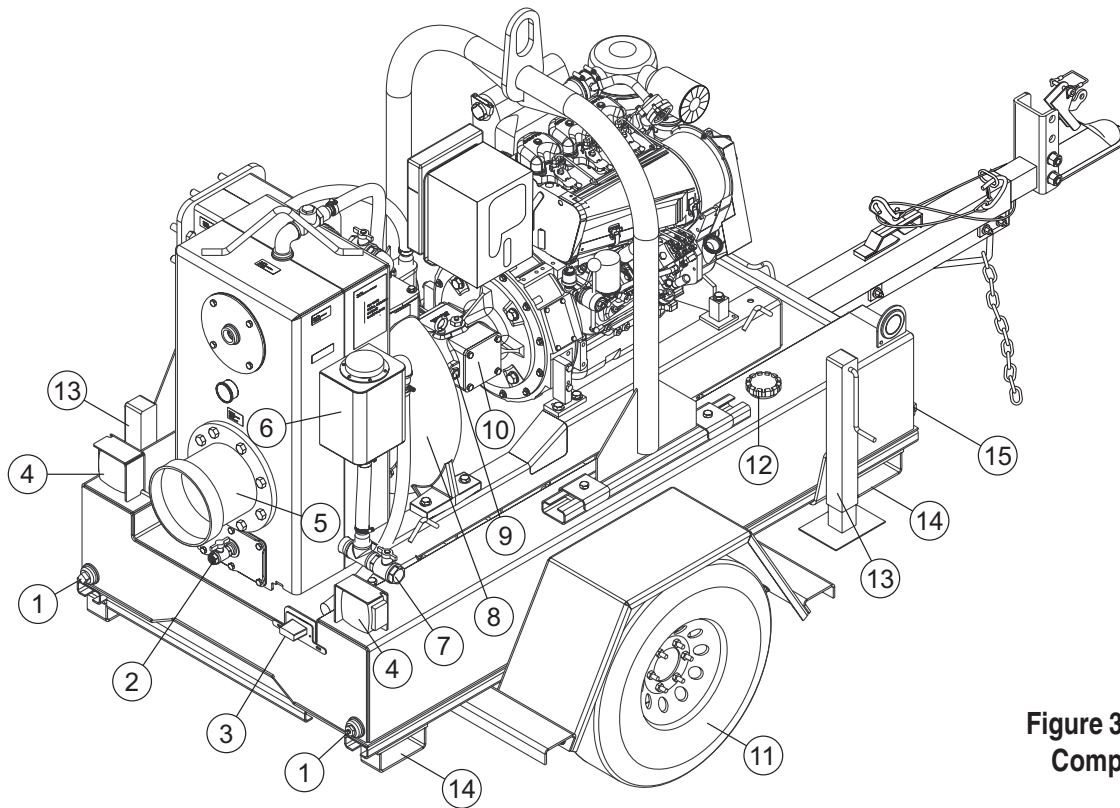

**Figure 3-A. Pump Components**

Figure 3-A shows the location of the components of the Dry Prime pump. The function of each component or control is described below:

1. **Rear Fuel Tank Drain Plugs** – Remove either plug to drain fuel.
2. **Primary Tank Drain Valve** – Open valve to drain water from priming tank. In freezing weather conditions water inside priming pump should always be drained.
3. **License Plate Light** – **ALWAYS** make sure light is working correctly before towing at night.
4. **Rear Tail Lights** – Before towing make sure both tail-lights are working correctly and are properly connected to the towing vehicle brake light system.
5. **Inlet Port** – Attach suction hose to this port. **ALWAYS** make sure suction hose is securely attached.
6. **Priming System Tank Fill Reservoir** – Used to fill inner priming tank and vacuum system.
7. **Priming System Drain Valve** – Open valve to drain in water priming tank.
8. **Impeller/Volute** – The impeller is a two-blade spiral open impeller connected to a drive shaft, when rotated creates a partial vacuum, drawing fluid through the pump creating suction. The volute houses the impeller.
9. **Bearing/Seal Sight Glasses** – Use these sight glasses to determine if oil is present. Oil must be **visible** midway at the sight glasses.
10. **Pump Driveshaft Access Panel** – Remove this panel to gain access to the pump driveshaft (gear) or second vacuum pump.
11. **Tires** – This pump uses XX-inch X-ply tires. Replace with only recommended type tires. Replace defective or worn tires immediately.
12. **Fuel Cap** – Remove to visually inspect fuel level and to refill fuel tank. Refuel using only recommended types of diesel fuel (see Deutz Manual). **DO NOT** top off fuel and wipe up any spilled fuel immediately.
13. **Jackstand** – Use jack stands to level and stabilize pump. **ALWAYS** make sure jack stands are deployed before operating pump.
14. **Tie Downs** – When transporting of the pump is required, use these tie-downs (4) to secure the pump.
15. **Front Fuel Tank Drain Plug** – Remove either plugs to drain fuel.

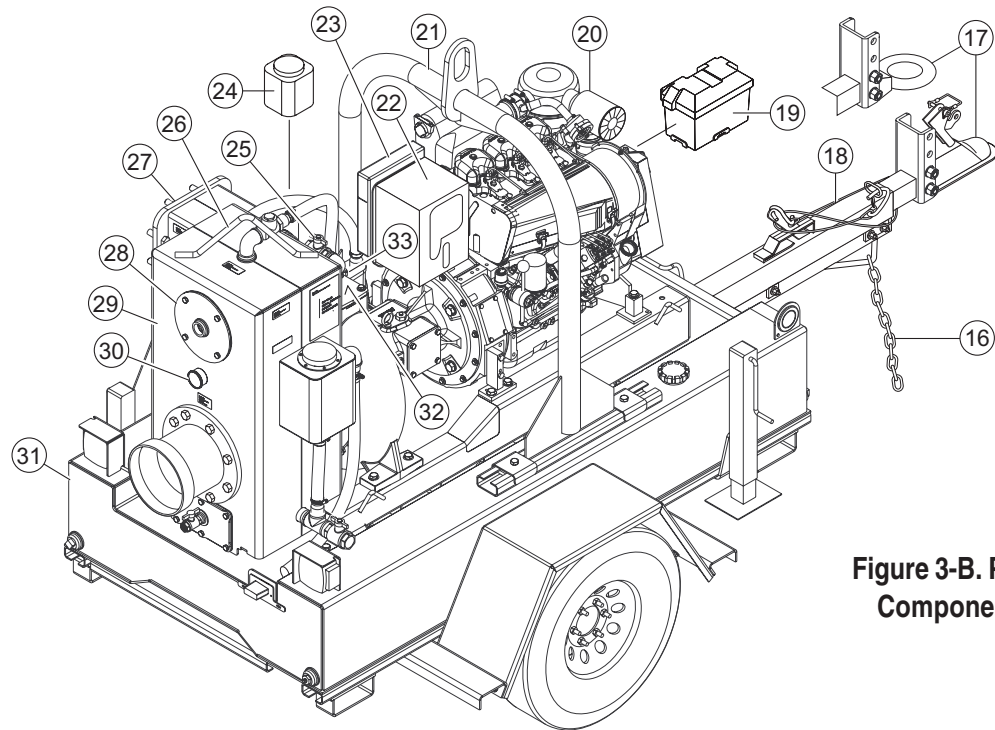

**Figure 3-B. Pump Components**

Figure 3-B shows the location of the more components of the Dry Prime pump, The function of each component or control is described below:

16. **Safety Chain** – **ALWAYS** attach safety chain to the towing vehicle. **NEVER** tow the pump with the safety chain unattached! See towing section of this manual.
17. **Towing Coupler/Ring** – Attach this coupler to the towing vehicle. Use only the specified ball diameter as indicated on your coupler (2-5/16). Use of any other ball diameter will create an extremely dangerous condition which can result in separation of the coupler and ball or ball failure. A 3-inch tow ring is also available as an option.
18. **Adjustable Tow Tongue** – Tow tongue is adjustable by removing locking pin to adjust tongue length then reinserting pin to lock tongue in place.
19. **Battery** – Unit uses a +12VDC wet battery Group 31.
20. **Engine** – These pumps are equipped with either a Deutz F3L914 or F4L914 three or four cylinder air-cooled diesel engine.
21. **Skid Lifting Bail** –When lifting of the pump skid is required, attach a strap or chain of adequate lifting capacity to lift the skid.
22. **Engine Control Box** – Vandal proof (lockable) engine control box displaying engine gauges, tachometer, temperature, battery voltage, hour meter, oil pressure and ignition switch.
23. **Document Box** – Contains all documentation relating to the pump or engine.
24. **Vacuum Pump Mechanical Seal Oil Reservoir** – Oil level should always be maintained to the **FULL** level marked on the bottle.
25. **Backflush Valve** – Open valve to backflush wellpoints or to clean suction strainer.
26. **Priming Tank Lifting Bail** – When removing of the priming tank is required, attach a strap or chain of adequate lifting capacity to lift vacuum pump.
27. **Pump Discharge** – Attach discharge hose to this port. **ALWAYS** make sure discharge hose is securely attached.
28. **Float Valve** – Regulates and controls vacuum level during pump operation. Consist of self-aligning reinforced rubber hinge that doubles as a seal and a one piece welded float assembly.
29. **Priming Tank** – Vacuum system that creates a vacuum in the outer priming tank, drawing water in. Water drawn into the outer priming tank then flows into the volute, priming the pump.
30. **Vacuum Gauge** – Vacuum gauge for priming system. Monitors air discharge. Required when troubleshooting.
31. **Fuel Tank** – Holds 140 gallons (530 liters) of diesel fuel
32. **Volute Inspection Cover** – Remove this cover to inspect or clear the impeller.
33. **Vacuum Pump** – This unit uses a direct-drive 60 CFM vacuum pump to remove large volumes of air to obtain priming for the pump.

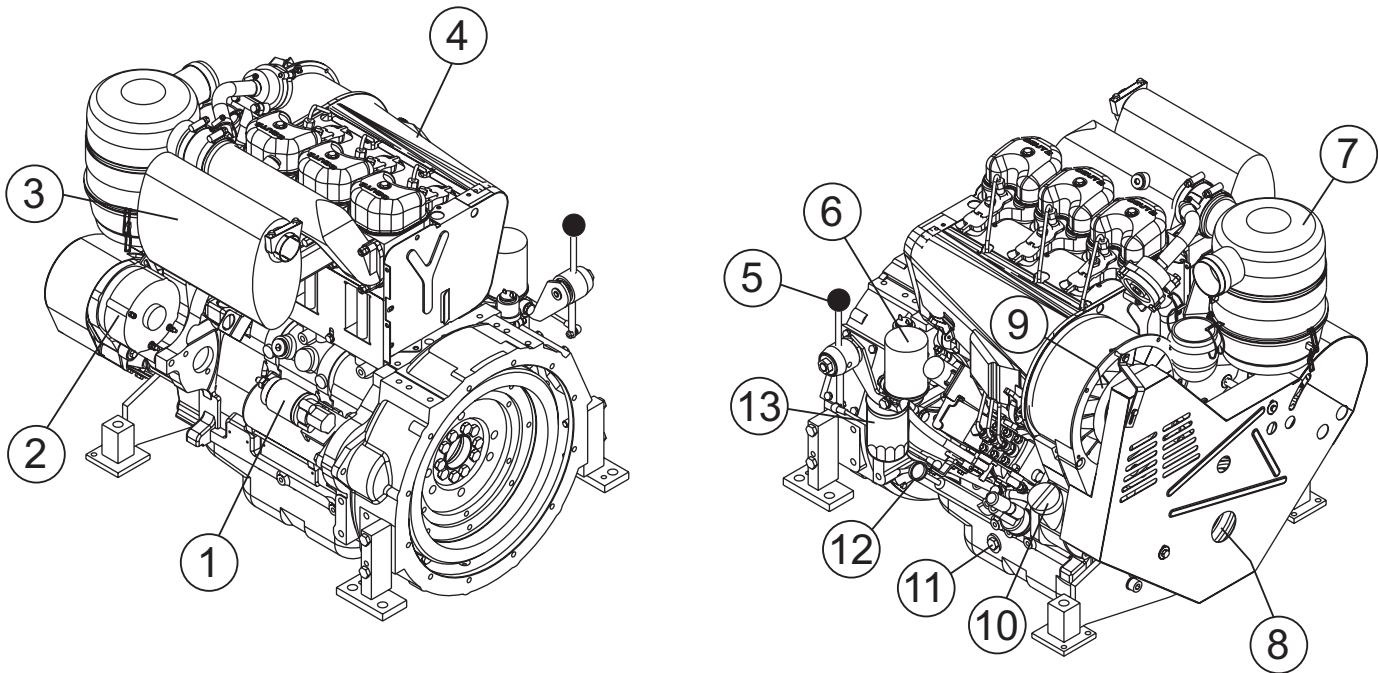

**Figure 4. Basic Engine Components**

Figure 4 illustrates the location of the basic components for the Deutz Model F3L914 and F4L914 Engines. The function of each component is described below:

1. **Starter Motor/Solenoid** – **NEVER** allow concrete or any foreign debris to come in contact with the starter motor/solenoid.
2. **Alternator** – (not shown) Provides power to the electrical system. Replace with only manufactures recommended type alternator.
3. **Muffler/Guard** – **DO NOT** touch the muffler when engine is running. The muffler can become extremely hot, causing severe burns. **NEVER** run the pump with the muffler guard removed.
4. **Engine** – Air-cooled, 4-stroke, 3 or 4 cylinder diesel engine. See Table 2 for detailed specifications.
5. **Engine Throttle Lever** – Controls the speed of the engine. For load conditions (pumping water) **ALWAYS** run the engine at **full speed**.
6. **Fuel Filter** – Replace or clean the fuel pump or fuel filter as specified in the maintenance section of this manual.
7. **Air Cleaner** – Prevents dirt and other debris from entering the fuel system. Remove wing-nut on top of air filter canister to gain access to filter element. Replace with only manufactures recommended type air cleaner.
8. **V-Belts** – **ALWAYS** make sure that V-belts are properly tensioned. Loose or defective V-belts can adversely affect the performance of the pump.
9. **Cooling Fan Blades** – Make sure that the blades of the cooling fan are not **bent or broken**. A damaged fan blade can cause the engine to run hot and overheat.
10. **Oil Filler Port Cap** – Remove this cap to add engine oil to the crankcase. Fill with recommended type oil as specified in the maintenance section of this manual.
11. **Crankcase Drain Plug** – Remove this plug to drain engine oil from the crankcase. Replace with recommended engine oil as specified in the maintenance section of this manual.
12. **Dipstick** – Remove this dipstick to determine if engine oil is low. Maintain oil level at the "H" marking on the dipstick. **NEVER** run engine with low oil.
12. **Oil Filter** – Replace oil filter as recommended in the maintenance section of this manual.

# ENGINE CONTROL BOX COMPONENTS

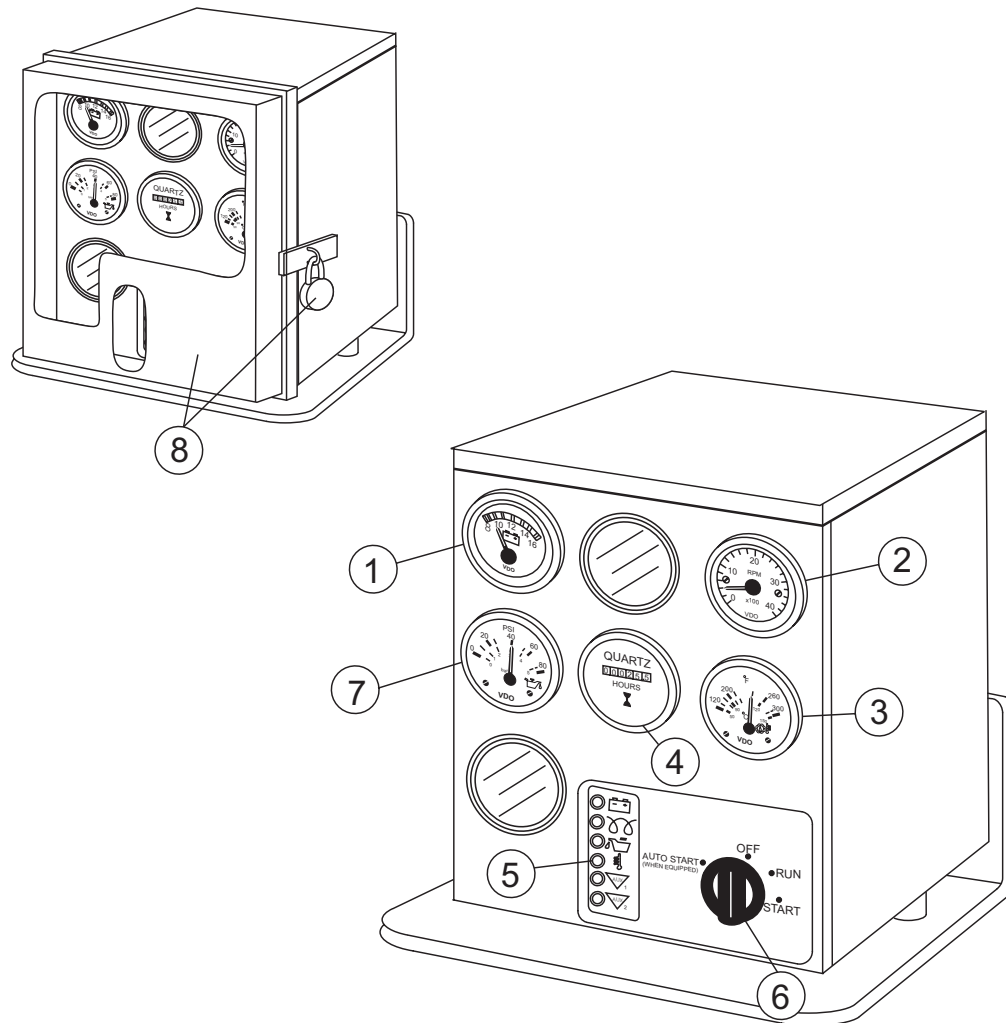

Figure 5. Control Box

Figure 5 shows the location of the components for the engine control box. The function of each component is described below:

1. **Voltmeter Gauge** – Indicates the battery charge.
2. **Engine Tachometer** – Monitors engine RPM's.
3. **Temperature Meter** - Indicates engine coolant temperature.
4. **Engine Hour Meter** – Displays the number of hours the engine has been in use.
5. **LED Panel**– contains LED fault indicators that light up to indicate battery discharge, low oil pressure, high temperature, alternator failure and V-belt failure. LED will remain lit indicating fault until reset.
6. **Engine ON/OFF Switch** – Turn the knob here to start the engine. Turn the knob clockwise to the **RUN** position, then continue turning clockwise to the **START** position and release. To stop the engine turn the knob fully counterclockwise to the **OFF** position.
7. **Oil Pressure Meter** - Monitors engine oil pressure.
8. **Vandal Cover** - Close cover and lock to prevent unauthorized personnel from starting engine.

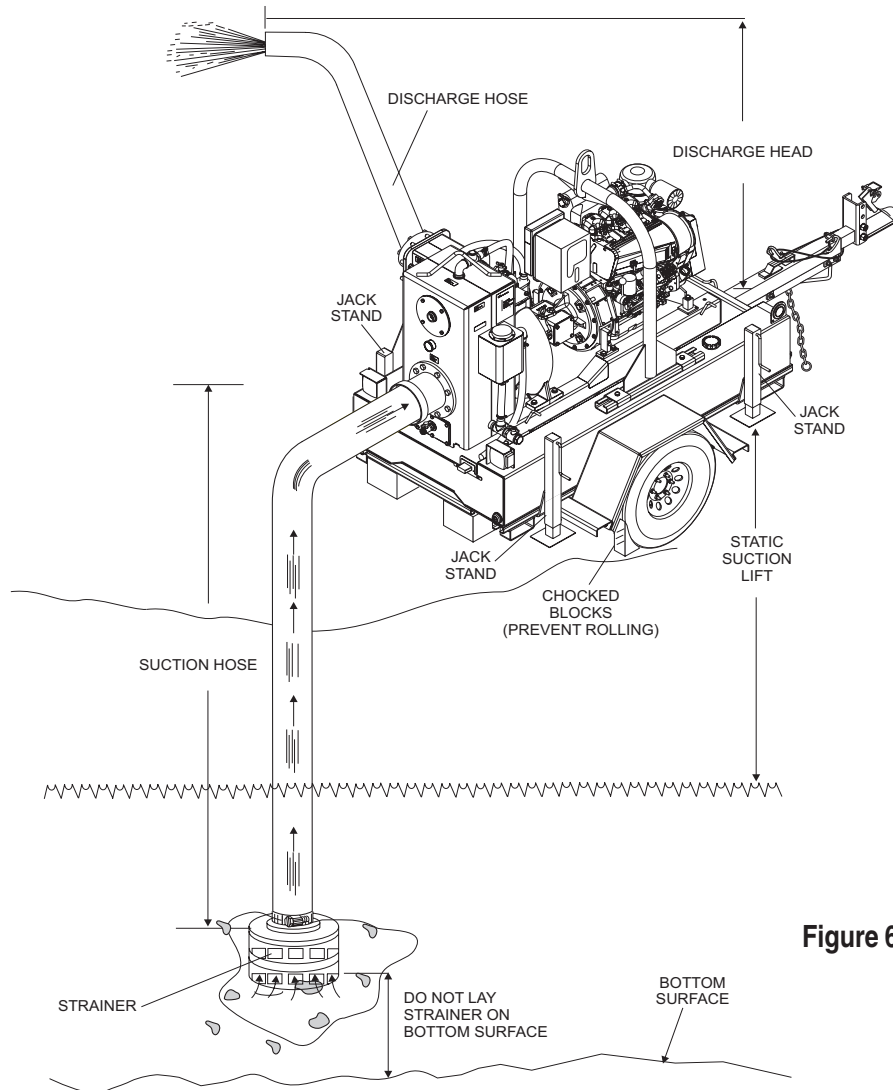

Figure 6. Pump Application

Figure 6 shows a typical application using the Dry Prime diesel-powered prime-assist pump. Please note that this pump is intended for the removal of clean water and water containing some debris and solids. Maximum size of solids should not exceed 3.2 inches (81.2 mm) in diameter. **DO NOT** set strainer on bottom of water bed.

Placing the strainer above the water bed will prevent the pump from drawing in excessive amounts of sand and foreign debris.

The following terms are usually used when referring to **lift** or **head**:

1. **Static Suction Lift** – The vertical distance from the water line to the center of the impeller.
2. **Static Discharge Head** – The vertical distance from the discharge outlet to the point of discharge or liquid level when discharging into the bottom of a water tank.
3. **Dynamic Suction Head** – The static suction lift plus the friction in the suction line. Also referred to as **total suction head**.
4. **Dynamic Discharge Head** – The static discharge head plus the friction in the discharge line. Also referred to as **total discharge head**.
5. **Total Dynamic Head** – The Dynamic Head Suction Head plus the Dynamic Discharge Head. Also referred to as **total head**.

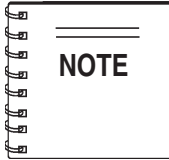

See "Trailer Safety Guidelines" section in this manual for a complete understanding on towing techniques.

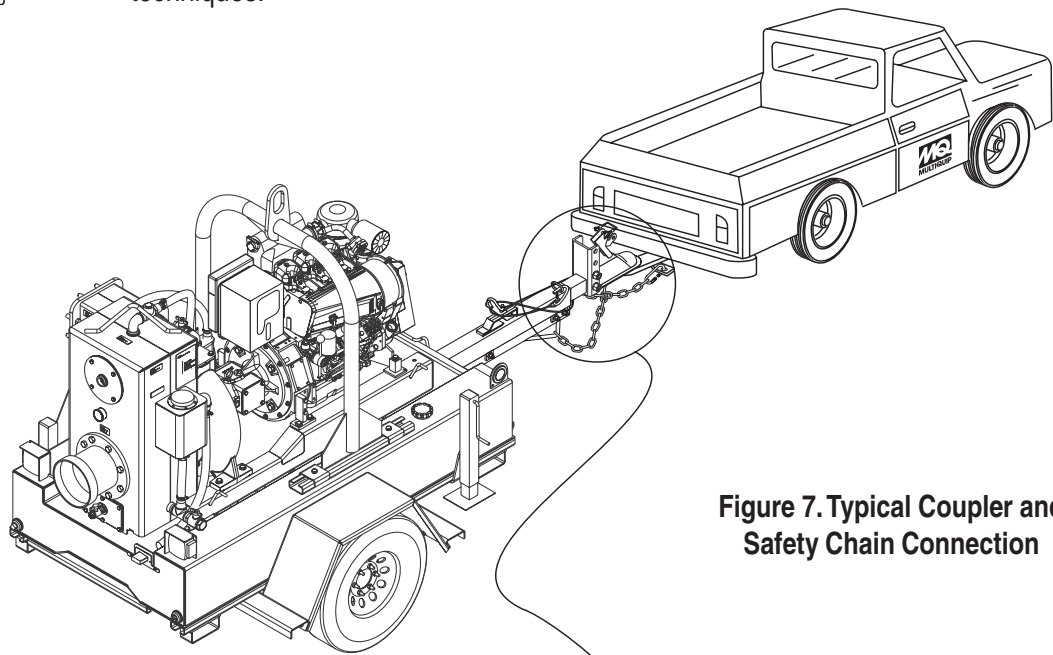
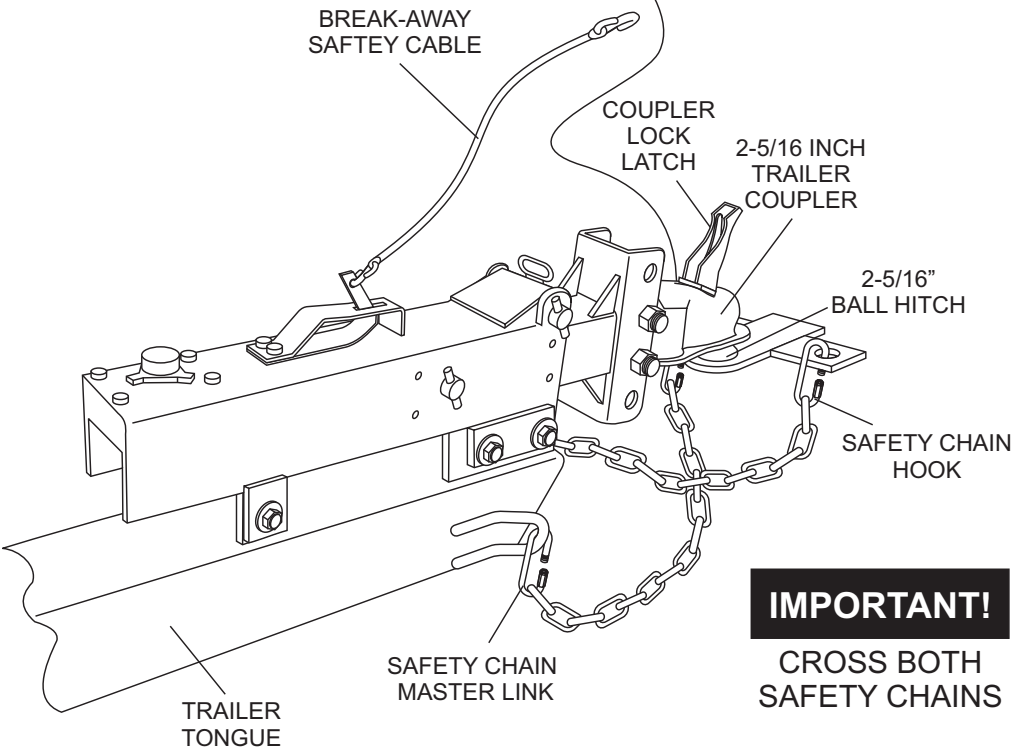

Figure 7. Typical Coupler and Safety Chain Connection



**IMPORTANT!**  
CROSS BOTH  
SAFETY CHAINS

## Before Starting

1. Read safety instructions at the beginning of manual.
2. Place pump as near to water as possible. Level the pump with jack stands. Rear jack stand on suction end of the pump must be used as the weight of the suction hose filled with liquid could cause the pump to tip. The jack stands can be moved from side to side and optional extra jack stands can be added.
3. Fill the vacuum system with water. Water level should be up to the middle of the hose below the priming system tank fill reservoir. Fill with clean water, free of solids or foreign material. Do not use salt water, water with abrasives, or acidic water as this will cause damage to the system. Non-polluting, environmentally-safe antifreeze should be used in freezing conditions.

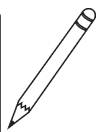
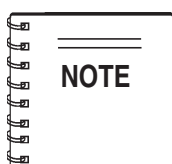

Pump will not be able to begin pumping unless the water level is up to the middle of the hose below the fill port tank.

4. Check for **leaks** between pump and engine. If water is leaking between the pump and bearing housing, the seal inside the pump may be worn or damaged. Continued operation of the pump is not recommended. Further usage of the pump under these conditions may cause severe water damage to bearing housing assembly.

## Suction and Discharge Hoses

1. Check that the suction hose is **securely** attached to the pump. Make certain suction hose (Figure 3) does not have any air leakage. Tighten hose clamps and couplings as required.
2. Shorter suction lift and suction hose length will produce better performance.
3. Make sure the **suction strainer** (Figure 6) is clean and securely attached to the water end of the suction hose. The strainer is designed to protect the pump by preventing large objects from being pulled into the pump. Failure to use a strainer could cause damage to the pump, impeller, pump shaft, pump bearings, or wear plate.
4. If a strainer becomes clogged with debris, the strainer can be cleared while the pump is running by opening the backflush valve.



## DANGER - High Pressure

PVC discharge hoses and thin-walled rubber hoses can easily fail at the end of the hose fittings. Leaks from the hoses can cause high-pressure liquid to be discharged, causing dangerous conditions. Make sure pressure rating of hoses exceeds the pump maximum pressure to prevent hose failure.



## CAUTION - Strainer Placement

The strainer should be positioned so it will remain completely **under water**. Running the pump with the strainer above water for long periods can damage the pump.

5. Multiple suction lines may be used but valves need to be installed in all lines to adjust for different flows and suction lift. Suction lines of lengths of 1000 feet or more will lower performance of the pump.
6. Check that the **discharge** hose (Figure 6) is securely attached and not restricted. Place hose so that it lays as straight as it is possible on the ground. Remove any twists or sharp bends from hose which may block the flow of water.
7. Light discharge hose should be anchored to avoid movement with high flow or high pressure.

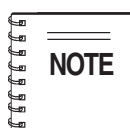

Suction and discharge hoses are available from Multiquip. Contact your nearest dealer for more information.



## DANGER - Flammable Fluids

**DO NOT** pump flammable fluids, corrosive chemicals or fluids containing toxic substances. These fluids can create potentially dangerous health and environmental hazards. Contact local authorities for assistance.

8. Always use a suction hose or pipe that matches the size of the pump inlet to insure optimum performance and reduce the risk of damage to the pump.
9. It is recommended that the discharge hose or pipe match the size of the pump outlet to reduce friction as much as possible. Using a discharge line that is larger than the pump outlet will reduce friction and improve water flow. Similarly, a smaller line will reduce water flow by increasing friction.



## Engine Oil

1. Make sure pump/engine is on level ground.
2. Pull the engine oil dipstick from its holder.
3. Verify that oil level (Figure 8) is maintained between the two notches on the dipstick.

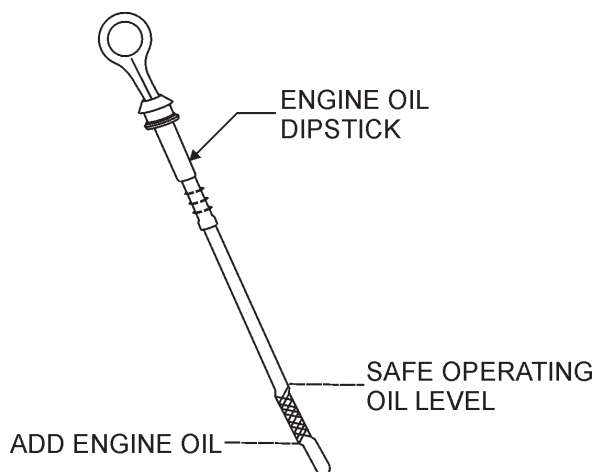

**Figure 8. Engine Oil Dipstick**

4. If engine oil is low, fill engine crankcase with lubricating oil through filler hole (Figure 9), but **DO NOT** overfill.

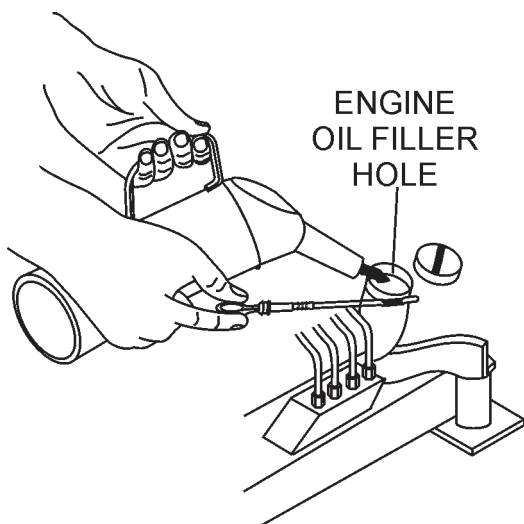

**Figure 9. Engine Oil Filler Hole**

5. The oil listed in Table 5 is recommended to ensure better engine performance. Use class CD or higher grade motor oil.

| -30 |  | -25 | -20 | -15         | -10 | -5           | 0°C | 5            | 10 | 15           | 20 | 25 | 30 |
|-----|--|-----|-----|-------------|-----|--------------|-----|--------------|----|--------------|----|----|----|
| ←   |  | ←   |     | ←           |     | ←            |     | ←            |    | ←            |    | ←  |    |
|     |  |     |     | SAE 0W - 30 |     |              |     |              |    |              |    |    |    |
|     |  |     |     | SAE 0W - 40 |     |              |     |              |    |              |    |    |    |
|     |  |     |     | SAE 5W - 30 |     |              |     |              |    |              |    |    |    |
|     |  |     |     | SAE 5W - 40 |     |              |     |              |    |              |    |    |    |
|     |  |     |     |             |     | SAE 10W - 30 |     |              |    |              |    |    |    |
|     |  |     |     |             |     | SAE 10W - 40 |     |              |    |              |    |    |    |
|     |  |     |     |             |     |              |     | SAE 15W - 40 |    |              |    |    |    |
|     |  |     |     |             |     |              |     |              |    | SAE 20W - 50 |    |    |    |

## Fuel

**! DANGER - Fire/Explosion**

**NEVER** fill the fuel tank while the engine is running or in the dark. Fuel spillage on a hot engine can cause a fire or explosion. If fuel spillage occurs, wipe up the spilled fuel completely to prevent fire hazards.

1. Remove the fuel cap from the trailer frame and visually inspect if the engine fuel level is low. If low, fill with recommended type diesel fuel. **DO NOT** fill the tank beyond capacity.
2. Handle fuel in a safety container. If the container does not have a spout use a funnel.
3. Pay attention to the fuel tank capacity when replenishing fuel. Refer to the fuel tank capacity listed in Engine Specification Table 1.
4. Tighten fuel tank cap securely after filling.

**! DANGER - No Smoking**

**DO NOT** smoke while refueling, motor fuels are highly flammable and can be dangerous if mishandled.

## Engine Startup

### Speed Control Lever

1. Set the **Speed Control Lever** (Figure 10) to a position half way between start and stop.

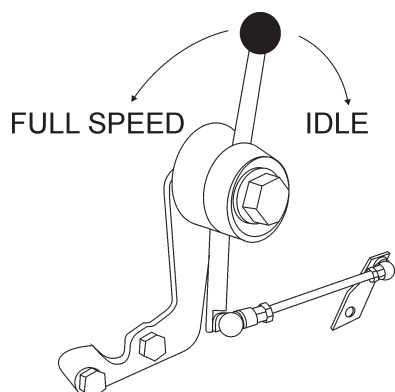

**Figure 10. Speed Control Lever**

### Engine Control Box

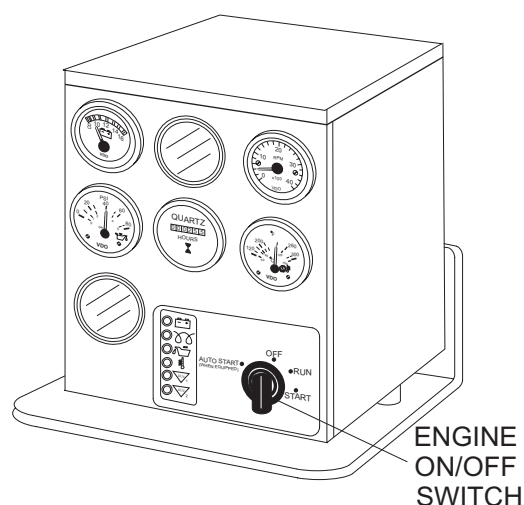

**Figure 11. Ignition Switch**

1. Turn engine start switch (see Figure 11) to the **RUN** position, and verify that voltmeter gauge indicates 12 VDC.
2. Verify that the **battery** and status LED indicator lamps are **ON**.
3. Continue turning the ignition key from the **RUN** position to the **START** position.

4. Release engine start stop switch as soon as engine starts, and verify that ignition switch automatically returns back to the **RUN** position.
5. Verify that the **battery charge** and status LED indicator lamps are **OFF**.
6. If battery charge indicator lamp remains lit, increase engine speed until light goes off. When the charge indicator light goes off, it can then be assumed that the charging system is working correctly.
7. If the charge light remains on while the engine is running, refer to Engine Troubleshooting or the Deutz Engine Repair Manual.
8. If the **AUX 1** status LED lamp is **ON**, stop engine and check for broken or defective V-belt.
9. Move **speed control lever** to full speed position for maximum engine speed.

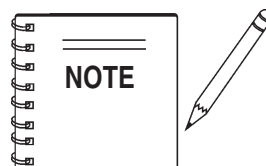

If engine does not start, place engine start/stop switch in **OFF** position to reset. Wait 10 seconds before restarting. Use hand fuel pump to remove air from fuel return line.

### Operation

1. The Dry Prime pump should begin pumping water within a minute depending on the length of suction hose and height the pump is above water.

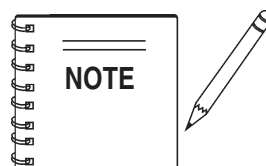

Longer suction hoses will require more time for the pump to begin pumping water.

2. If pump does not begin to pump water after a few minutes, check for loose connections or air leaks in suction hose. Make sure there is water in the vacuum system and strainer is not clogged with debris, reference Pump Troubleshooting Flowchart.

## Engine Shut-Down

1. Place **speed control lever** in the idle position and place the engine start/stop switch in the **OFF** position.
2. Close vandal cover on engine control box, and lock. Store pad lock key in a safe place, out of the reach of unauthorized persons.

### CAUTION - Locking Engine Control Box

When the pump is not in use, **close the vandal cover** on the engine control box and **lock**. Locking the engine control box will prevent unauthorized personnel from starting the pump. Store key in a safe place.



### CAUTION - Disconnecting Discharge Hose

If pumping in a positive head (pumping up hill), be sure to open discharge check valve drain and release pressure before uncoupling hose.

## Pump Inspection After Use

It is recommended that the pump be inspected after use for damage or wear.

1. Drain and flush pump volute and priming system. Usually from suction end.
2. Inspect impeller for wear or damage and measure impeller clearance if it appears worn. Inspect interval should be about every 1000 hours. This inspection should be done when the pump is scheduled for maintenance inspection.
3. Inspect discharge check valve for wear or damage. Replace if necessary.
4. Inspect fuel tank and check for water by removing 0.5-inch drain plugs. Do not overtighten when replacing.
5. Check oil reservoirs for contamination or water.
6. Do dry vacuum test to check seal and check valve seal. This check should be done when the pump is scheduled for maintenance inspection.

## Pump Storage

For storage of the pump for over 30 days, the following is required:

- Drain the fuel tank completely.
- Run the engine until the fuel in the injection system is completely consumed.
- Completely drain used oil from the engine crankcase and fill with fresh clean oil, then follow the procedures described in the engine manual for engine storage.
- Remove the drain plug from the pump and drain out any water from left in the housing.
- Remove the pump cover and clean inside of pump housing. Coat inside of pump housing with a light film of oil to reduce corrosion. A spray can of oil works well for this application.
- Cover suction and discharge ports with duct tape to prevent any foreign matter from falling into pump.
- Cover pump and engine with plastic covering or equivalent and store in a clean, dry place.

## Engine Maintenance

To ensure longer pump life and service, please follow the pump maintenance guidelines as listed in Table 6 and on preceding pages.

| Table 6. Pump Maintenance |  |
|---------------------------|--|
| Daily                     | Check bearing housing.   |
|                           | Check pump seal oil reservoir  |
|                           | Check vacuum pump seal oil reservoir.  |
|                           | Check water level in vacuum system and anti-freeze concentration for weather conditions.                             |
|                           | Check for leaks and kinks in discharge hose.   |
| Every 250 Hours           | Check if water is clean and anti-freeze is right for conditions in vacuum system.                                    |
|                           | Check oil reservoirs for bearings, pump seal and vacuum pump seal for contamination, drain and replace if necessary. |
|                           | Check impeller bolt for tightness.   |
| Every 500 Hours           | Flush vacuum system water tank and fill with clean water. Add antifreeze if necessary.                               |
|                           | Check impeller condition and clearance. Adjust clearance as needed.  |
| Every 1000 Hours          | Change oil in pump seal, pump bearing housing, and vacuum pump seal reservoirs.                                      |
|                           | Inspect discharge check valve for wear. Replace if necessary.  |
| Every 2000 Hours          | Grease vacuum pump bearings.   |

## Dry Pump Vacuum Test

To perform the pump vacuum test do the following:

1. Perform all start-up steps without installing the hoses.
2. Block the suction with a plug or heavy rubber flap as shown in Figure 12. An accurate vacuum gauge should be installed in the plug or flap to check vacuum system performance and pump vacuum gauge.
2. Start the engine and run at 1,800 RPM. Note the maximum vacuum reading.
3. Shut off the engine and check the vacuum reading. The vacuum reading should be .75 to .9 Bar or 25 to 27 inches. Vacuum reading should hold for about 3 to 10 minutes before dropping to zero. If vacuum reading drops fast, check for leaks and repair if necessary. Listen for leaks. If area is quiet, small air leaks should be easy to hear.

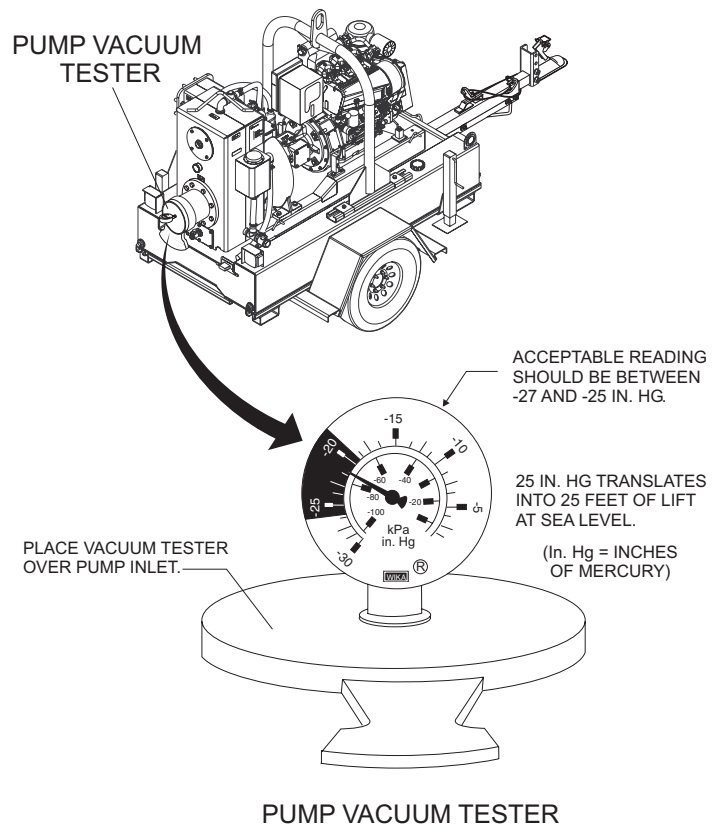

Figure 12. Dry Pump Vacuum Test

## Engine Maintenance

The following engine maintenance guidelines are intended to assist the operator in preventative maintenance. For a more detailed maintenance schedule refer to the **Deutz Engine Instruction Manual** supplied with the pump.

## Changing Engine Oil

Change engine oil after first 20 hours of operation. Drain and refill engine crankcase with the correct type and amount oil (reference Table 5) after 250 hours of operation hours or once a week thereafter.

When draining engine crankcase oil, place oil into a suitable container while engine is still warm. Replace the drain plug tightly. Add oil through the filler hole.

## Changing Oil Filter

Change the Deutz engine oil filter (Figure 13) after 250 hours of operation.



Figure 13. Oil Filter Element

## Fuel Filter System

The Deutz engine fuel system incorporates four different types of fuel filters, in-line, easy change, IMSA, and a fuel water separator.

### In-line Fuel Filter

Replace the in-line fuel filter (Figure 14) every 500 hours. If the purity of the fuel being used is of lesser quality replace the in-line fuel filter more often as needed.

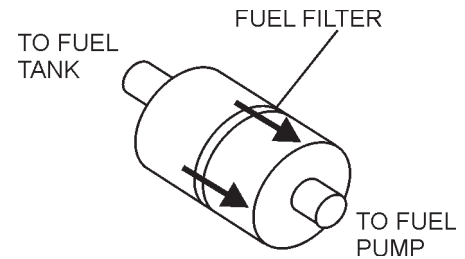
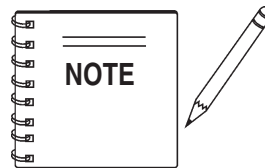

Figure 14. In-Line Fuel Filter



When reinstalling fuel filters, please note the arrows indicating the **direction of fuel flow**.

### Easy-Change Fuel Filter

Replace the easy change fuel filter (Figure 15) every 500 hours.



Figure 15. Easy-Change Fuel Filter

### Cleaning the IMSA Fuel Filter

1. Close the fuel shut-off valve and loosen the retaining on the IMSA fuel filter (Figure 16).
2. Remove the cover and the fuel strainer.
3. Clean the fuel strainer with diesel fuel. Replace fuel strainer if necessary.
4. Reassemble IMSA fuel filter.
5. Bleed fuel system and check for fuel leaks.

## IMSA Fuel Filter

Inspect and clean (replace if necessary) the IMSA fuel filter (Figure 16) every 500 hours. This filter is part of the fuel pump.

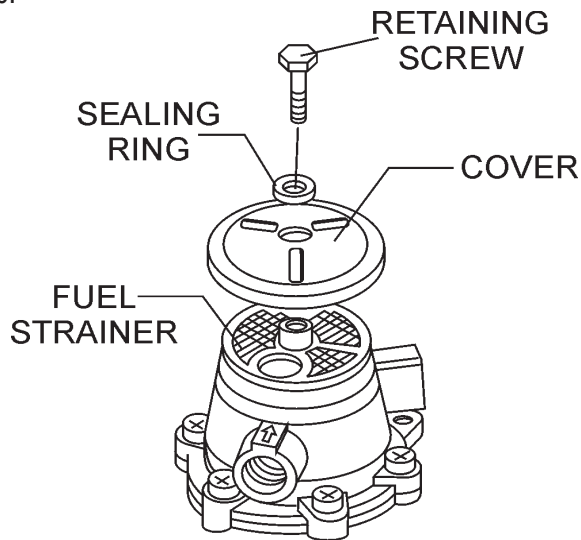

**Figure 16. IMSA Fuel Filter**

## Fuel Tank

Unscrew the fuel drain plug on the fuel tank (Figure 18) to remove water and sediment every 500 hours. If the purity of the fuel being used is of lesser quality drain the fuel tank more frequently.

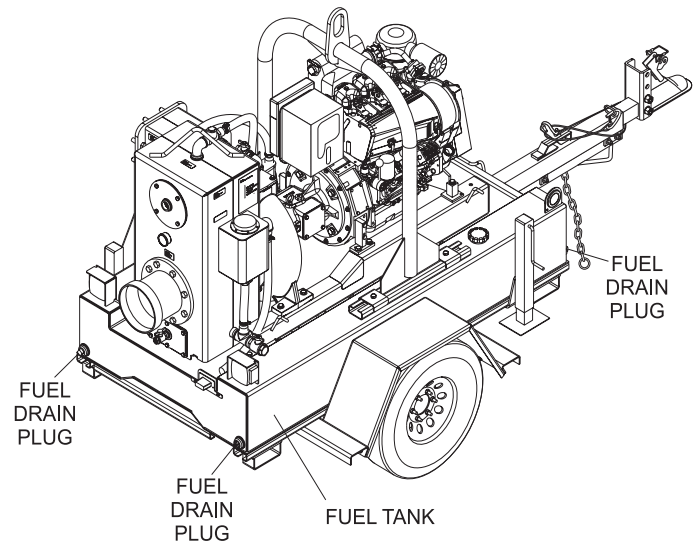

**Figure 18. Fuel Tank/Drain Plug**

## Fuel Water Separator Filter

1. Inspect the fuel water separator (Figure 17) every 40 hours. If the fuel water separator requires maintenance follow steps 2 and 3 below:

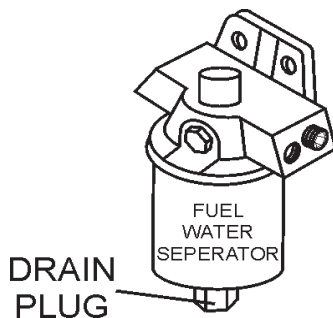

**Figure 17. Fuel Water separator Filter**

2. Open the drain plug on the fuel water separator (Figure 18) to remove any sediment or water that may have accumulated in the fuel water separator reservoir.
3. After water and sediment and foreign debris has been drained from the fuel water separator, reinstall the drain plug on fuel water separator.

The following trailer maintenance guidelines are intended to assist the operator in preventative maintenance.

## Trailer Brakes

Properly functioning brake shoes and drums are essential to ensure safety. The brakes should be inspected the first 200 miles of operation. This will allow the brake shoes and drums to seat properly. After the first 200 mile interval, inspect the brakes every 3,000 miles. If driving over rough terrain, inspect the brakes more frequently.

## Surge Brakes

If your trailer has surge-operated brakes, they function the same way the surge brakes do on your tow vehicle. The surge braking system must be inspected at least as often as the brakes on the tow vehicle, but no less than once per year. This inspection includes an assessment of the condition and proper operation of the wheel cylinders, brake shoes, brake drums and hubs.

## Manually Adjusting the Brakes

Most axles are fitted with a brake mechanism that will adjust the brakes during a hard stop. However, some braking systems are not automatically adjusted by hard stopping. These brakes require manual adjustment. The following steps apply to adjust most manually adjustable brakes.

1. Jack up the trailer and secure it on adequate capacity jack stands.
2. Be sure the wheel and brake drum rotate freely.
3. Remove the adjusting-hole cover from the adjusting slot on the bottom of the brake backing plate.
4. With a screwdriver or standard adjusting tool, rotate the starwheel of the adjuster assembly to expand the brake shoes. Adjust the brake shoes out until the pressure of the linings against the drum makes the wheel very difficult to turn. Note: Your trailer maybe equipped with drop spindle axles. See axle manual for your axle type. You will need a modified adjusting tool for adjusting the brakes in these axles. With drop spindle axles, a modified adjusting tool with about an 80 degree angle should be used.
5. Rotate the starwheel in the opposite direction until the wheel turns freely with a slight drag.
6. Replace the adjusting-hole cover.
7. Repeat the above procedure on all brakes.
8. Lower the trailer to the ground.

You must check the fluid level in the master cylinder reservoir at least every three months. If you tow your trailer an average of 1,000 miles per month in a hot and dry environment, you must check the brake fluid level once a month. The brake fluid reservoir is located on the tongue of the trailer. Always fill with clean, uncontaminated DOT 4 brake fluid.

Figure 19 below displays the major air/surge brake components that will require inspection and maintenance. Please inspect these components as required using steps 1 through 6 as referenced in the "Manually Adjusting The Brakes" section on this page. See Table 11 Surge Brake Troubleshooting.

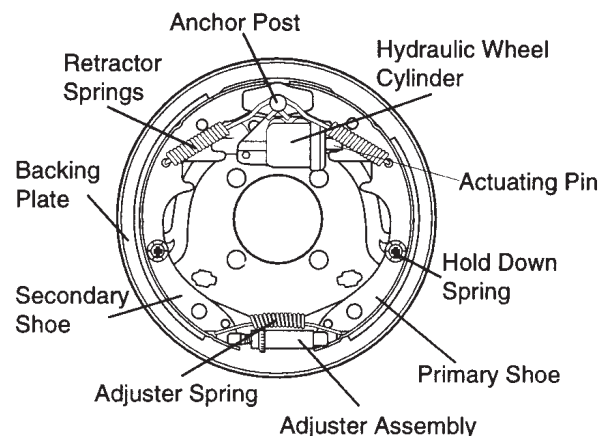

**Figure 19. Surge Brake Components**

## Electric Brakes

Electrically actuated brakes (Figure 20) are similar to surge brakes. The basic difference is that surge brakes are actuated by an electromagnet. Listed below are some of the advantages that electric brakes have over surge brakes:

- Brake system can be manually adjusted to provide the corrected braking capability for varying road and load conditions.
- Brake system can be modulated to provide more or less braking force, thus easing the brake load on the towing vehicle.
- Brake system has very little lag time between the time the vehicle's brakes are actuated and the trailer's brakes are actuated.
- Brake system can provide an independent emergency brake system.

Remember in order to properly synchronize the tow vehicle's braking to the trailer's braking, can only be accomplished by road testing. Brake lockup, grabbiness or harshness is due to lack of synchronization between the tow vehicle and the trailer being towed or under-adjusted brakes.

Before any brake synchronizations adjustments can be made, the trailer brakes should be burnished-in by applying the brakes 20-30 times with approximately a 20 m.p.h. decrease in speed, e.g. 40 m.p.h. to 20 m.p.h. Allow ample time for brakes to cool between application. This allows the brake shoes to slightly be seated into the brake drum surface.

Figure 20 displays the major electric brake components that will require inspection and maintenance. Please inspect these components as required. See Table 12 Electric Brake Troubleshooting.

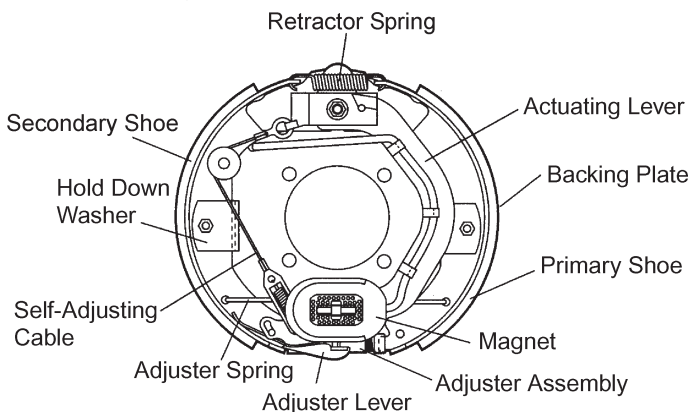

**Figure 20. Electrical Brake Components**

### Breakaway Battery

This battery supplies the power to operate the trailer brakes if the trailer uncouples from the tow vehicle. Be sure to check, maintain and replace the battery according to the battery manufacturer's instructions.

### Breakaway Switch

This switch causes the breakaway battery to operate the electric brakes if the trailer uncouples from the tow vehicle. The pull cable for the pull pin is connected to the tow vehicle, and the switch is connected to the trailer. To check for proper functioning of the switch, battery and brakes, you must pull the pin from the switch and confirm that the brakes apply to each wheel. You can do this by trying to pull the trailer with the tow vehicle, after pulling the pin. The trailer brakes may not lock, but you will notice that a greater force is needed to pull the trailer.

## WARNING - Breakaway Brake System

If electric breakaway brakes do not operate when trailer is uncoupled from the tow vehicle, death or serious injury can occur.

Check emergency breakaway brake system **BEFORE** each tow.

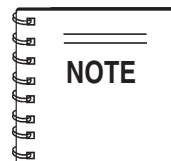

The electric brakes that operate in conjunction with the tow vehicle brakes must be **"synchronized"** so that braking is properly distributed to the tow vehicle brakes and the trailer brakes. For proper operation and synchronization, read

and follow the axle/brake and the brake controller manufacturers' instructions. To make certain an electrically-operated braking system will function properly, you must have your dealer inspect the magnets at least once a year, or each 12,000 miles. See the brake manual for wear and current inspection instructions.

### Hydraulic Brake Actuator

The surge brake actuator (Figure 21) is the mechanism that activates the trailer's brake system. This actuator changes fluid power into mechanical power. Therefore, the fluid level must be checked frequently to assure that the brakes function properly.

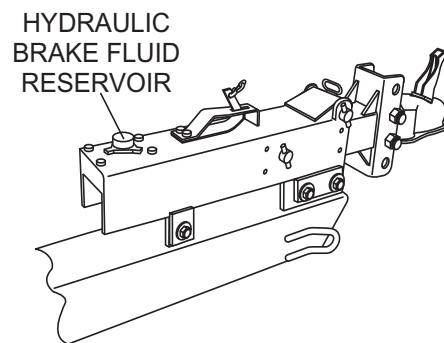

**Figure 21. Trailer Actuator**

## WARNING - Actuator Fluid Level

Failure to maintain proper fluid level in the actuator may result in loss of braking action which could cause severe property damage, injury or death.



Periodically check the actuator mounting fasteners for damage or loosening. Inspect the actuator for worn or damaged parts. As you are towing your trailer, be aware of any changes in braking quality. This could be an early warning of brake or actuator malfunction and requires immediate attention. Consult a certified brake specialist to make necessary adjustment or repairs.

## Adjustable Channel

Your trailer may be equipped with an adjustable channel (Figure 22) that allows the coupler to be raised or lowered to a desired height. Periodically check the channel bolts for damage or loosening.

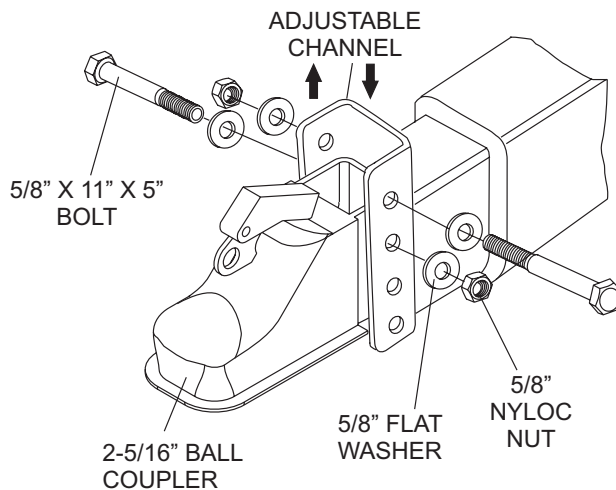

**Figure 22. Adjustable Channel With Pintle Eye Coupler**

## Wheel Bearings (Hubs)

Wheel bearings (Figure 23) must be inspected and lubricated once a year or 12,000 miles to insure safe operation of your trailer.

If a trailer wheel bearing is immersed in water, it must be replaced.

If the pump/trailer has not been used for an extended amount of time, have the bearings inspected and packed more frequently, at least every six months and prior to use. Follow the steps below to disassemble and service the wheel bearings.

- After removing the dust cap, cotter pin, spindle nut and spindle washer, remove the hub and drum to inspect the bearings for wear and damage.

## **!** DANGER - Wheel Bearings

If trailer wheels are under water for a long period of time, wheel bearings may fail. If this is the case, service wheel bearings immediately.

The possibility exists of the wheels falling off, causing equipment damage and severe bodily harm even death!

- Replace bearings that have flat spots on rollers, broken roller cages, rust or pitting. Always replace bearings and cups in sets. The inner and outer bearings are to be replaced at the same time.
- Replace seals that have nicks, tears or wear.
- Lubricate the bearings with a high quality EP-2 automotive wheel bearing grease.

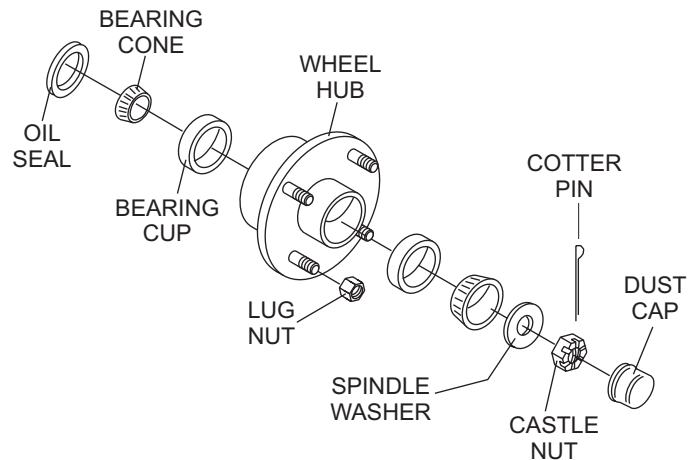

**Figure 23. Wheel Hub Components**

## Wheel Hub Adjustment

Every time the wheel hub is removed and the bearings are reassembled, follow the steps below to check the wheel bearings for free running and adjust.

- Turn the hub slowly, by hand, while tightening the spindle nut, until you can no longer turn the hub by hand.
- Loosen the spindle nut just until you are able to turn it (the spindle nut) by hand. Do not turn the hub while the spindle nut is loose.
- Install a new cotter pin through the spindle nut and axle.
- Check the adjustments. Both the hub and the spindle nut should be able to move freely (the spindle nut motion will be limited by the cotter pin).

# TRAILER MAINTENANCE

## **!** Danger - Raising the Trailer

**NEVER!** crawl under the trailer unless it is on firm and level ground and resting on properly placed and secured jack stands.

The possibility exists of the trailer falling thus causing equipment damage and severe bodily harm even **death!**

## **!** DANGER - Trailer Inspection

When performing trailer inspection and maintenance activities, you must jack up the trailer using jacks and jack stands.

When jacking and using jack stands, place them so as to clear wiring, brake lines, and suspension parts (i.e., springs, torsion bars). Place jacks and jack stands inside of the perimeter strip on the supporting structure to which the axles are attached.

## **!** WARNING - Trailer Impact

If the trailer is involved in an accident have it inspected immediately by qualified personnel. In addition, the trailer should be inspected annually for signs of wear or deformations.

## **!** WARNING - Cracked or Broken Welds

Improper weld repair will lead to early failure of the trailer structure and can cause serious injury or death.

**DO NOT** repair cracked or broken welds unless you have a **certified welder** perform the repair. If not, have the welds repaired by your dealer.

## **!** Danger - Trailer Welds

Broken or damaged welds can cause injury or severe damage to your trailer and contents. Inspect all of the welds for cracks or failure at least twice a year.

## Torsion Suspension

The mounting bracket (Figure 24) of the torsion suspension assembly is bolted directly to the trailer frame. Except for periodic inspection of the bracket's fasteners to the trailer frame, no other suspension maintenance is required on the axles.

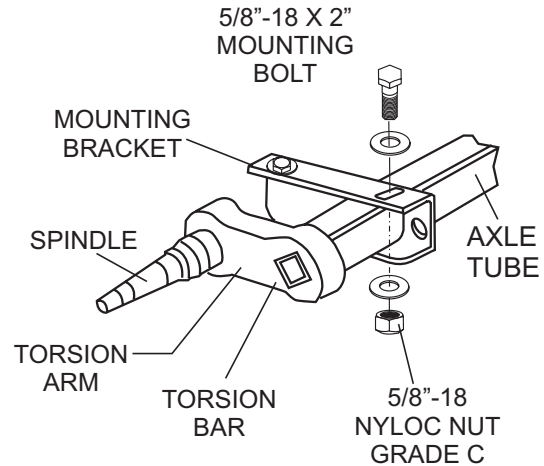

Figure 24. Torsion Suspension

## **!** Danger - Worn or Defective Suspension

Worn or broken suspension parts can cause loss of control, damage to equipment and severe bodily injury even **death!**

Check suspension regularly.

# TRAILER SAFETY GUIDELINES

## TRAILER SAFETY INFORMATION

Safety precautions should be followed at all times when operating this equipment. Failure to read, understand and follow the Operating Instructions could result in injury to yourself and others. Loss of control of the trailer or tow vehicle can result in death or serious injury.

### Common Causes for Loss of Trailer

- Driving too fast for the conditions (maximum speed when towing a trailer is 60 m.p.h.).
- Overloading the trailer or loading the trailer unevenly
- Trailer improperly coupled to the hitch
- No braking on trailer
- Not maintaining proper tire pressure
- Not keeping lug nuts tight
- Not properly maintaining the trailer structure.

### Trailer Towing Guidelines

- Recheck the load tiedowns to make sure the load will not shift during towing.
- Before towing, check coupling, safety chain, safety brake, tires, wheels and lights.
- Check the lug nuts or bolts for tightness.
- Check coupler tightness after towing 50 miles.
- Adjust the brake controller to engage the trailer brakes before the tow vehicle brakes. Your dealer can assist you by making this adjustment.
- Use your mirrors to verify that you have room to change lanes or pull into traffic.
- Use your turn signals well in advance. Allow plenty of stopping space for your trailer and tow vehicle.
- Allow plenty of stopping space for your trailer and tow vehicle.
- **DO NOT** drive so fast that the trailer begins to sway due to speed.
- Allow plenty of room for passing. A rule of thumb is that the passing distance with a trailer is 4 times the passing distance without the trailer.
- Shift your automatic transmission into a lower gear for city driving.

- **ALWAYS** use lower gears for climbing and descending grades.
- **DO NOT** ride the brakes while descending grades, they may get so hot that they stop working. Then you will potentially have a runaway tow vehicle and trailer.
- To conserve fuel, don't use full throttle to climb a hill. Instead, build speed on the approach.
- Slow down for bumps in the road. Take your foot off the brake when crossing the bump.
- **DO NOT** brake while in a curve unless absolutely necessary. Instead, slow down before you enter the curve and power through the curve. This way, the towing vehicle remains in charge.
- **DO NOT** apply the brakes to correct extreme trailer swaying. Continued pulling of the trailer, and even slight acceleration, will provide a stabilizing force.
- Anticipate the trailer "swaying." Swaying is the trailer reaction to the air pressure wave caused by passing trucks and busses. Continued pulling of the trailer provides a stabilizing force to correct swaying. **DO NOT** apply the brakes to correct trailer swaying.
- Use lower gear when driving down steep or long grades. Use the engine and transmission as a brake. Do not ride the brakes, as they can overheat and become ineffective.
- Be aware of your trailer height, especially when approaching roofed areas and around trees.
- Make regular stops, about once each hour. Confirm that:
  - A. Coupler is secure to the hitch and is locked.
  - B. Electrical connectors are made.
  - C. There is appropriate slack in the safety chains.
  - D. There is appropriate slack in the breakaway switch pullpin cable.
  - E. Tires are not visibly low on pressure



### WARNING - Drive Safely

Driving too fast for severe road conditions can result in loss of control and cause death or serious injury.

Decrease your speed as road, weather and lighting conditions deteriorate.

**ALWAYS** check for local trailer-tow speed limits in your area.

# TRAILER SAFETY GUIDELINES

## CAUTION - Local Towing Regulations

Check with your county or state safety towing regulations department before towing your *pump*.

## Driving Conditions

When towing a trailer, you will have decreased acceleration, increased stopping distance, and increased turning radius (which means you must make wider turns to keep from hitting curbs, vehicles, and anything else that is on the inside corner). In addition, you will need a longer distance to pass, due to slower acceleration and increased length.

- Be alert for slippery conditions. You are more likely to be affected by slippery road surfaces when driving a tow vehicle with a trailer, than driving a tow vehicle without a trailer.
- Check rearview mirrors frequently to observe the trailer and traffic.
- **NEVER** drive faster than what is safe.

## WARNING - Transporting Personnel

**DO NOT** transport people on the trailer. The transport of people puts their lives at risk and may be illegal.

## Coupling to the Tow Vehicle

Follow all of the safety precautions and instructions in this manual to ensure safety of persons, equipment, and satisfactory life of the trailer. Always use an adequate tow vehicle and hitch. If the vehicle or hitch is not properly selected and matched to the Gross Vehicle Weight Rating (GVWR) of your trailer, you can cause an accident that could lead to death or serious injury.

If you already have a tow vehicle, know your vehicle tow rating and make certain the trailer's rated capacity is less than or equal to the tow vehicle's rated towing capacity. If you already have (or plan to buy) a trailer, make certain that the tow rating of the tow vehicle is equal to or greater than that of the trailer.

The trailer VIN tag contains the critical safety information for the use of your trailer. Again, be sure your hitch and tow vehicle are rated for the Gross Vehicle Weight Rating of your trailer.

## WARNING - Coupler Selection/Condition

Proper selection and condition of the coupler and hitch are essential to safely towing your trailer. A loss of coupling may result in death or serious injury.

- Be sure the hitch load rating is equal to or greater than the load rating of the coupler
- Be sure the hitch size matches the coupler size
- Observe the hitch for wear, corrosion and cracks before coupling. Replace worn, corroded or cracked hitch components before coupling the trailer to the tow vehicle

Be sure the hitch components are tight before coupling the trailer to the tow vehicle.

## WARNING - Coupler Connection

An improperly coupled trailer can result in death or serious injury.

**DO NOT** move the trailer until:

- The coupler is secured and locked to hitch
- The safety chains are secured to the tow vehicle
- The trailer jack(s) are fully retracted

**DO NOT** tow the trailer on the road until:

- Tires and wheels are checked
- The trailer brakes are checked
- The breakaway switch is connected to the tow vehicle
- The load is secured to the trailer
- The trailer lights are connected and checked

## DANGER - Hitch/Tow Vehicle Load Rating

Use of a hitch with a load rating less than the load rating of the trailer can result in loss of control and may lead to death or serious injury.

Use of a tow vehicle with a towing capacity less than the load rating of the trailer can result in loss of control, and may lead to death or serious injury.

Be sure your hitch and tow vehicle are rated for the Gross Vehicle Weight Rating of your trailer.

## Reporting Safety Defects

If you believe that your vehicle has a defect that could cause a crash or could cause injury or death, you should immediately inform the National Highway Traffic Safety Administration (NHTSA) in addition to notifying us.

If NHTSA receives similar complaints, it may open an investigation, and if it finds that a safety defect exists in a group of vehicles, it may order a recall and remedy campaign. However, NHTSA cannot become involved in individual problems between you, your dealer, or us.

To contact NHTSA, you may either call the Vehicle Safety Hotline toll-free at 1-888-327-4236 (TTY: 1-800-424-9153), go to <http://www.safercar.gov>; or write to:

Administrator  
NHTSA  
1200 New Jersey Avenue S.E.  
Washington, DC 20590

You can also obtain other information about motor vehicle safety from <http://www.safercar.gov>.

## Inoperable Brakes, Lights or Mirrors

Be sure that the brakes and all of the lights on your trailer are functioning properly before towing your trailer. Check the trailer taillights by turning on your tow vehicle headlights. Check the trailer brake lights by having someone step on the tow vehicle brake pedal while you look at trailer lights. Do the same thing to check the turn signal lights. (See Trailer Wiring Diagram section in this manual.)

Standard mirrors usually do not provide adequate visibility for viewing traffic to the sides and rear a towed trailer. You must provide mirrors that allow you to safely observe approaching traffic.

### **WARNING - Checking Taillights/Brakelights**

Improper electrical connection between the tow vehicle and the trailer will result in inoperable lights and electric brakes, and can lead to collision.

Before each tow:

- Check that the taillights, brake lights and turn signals work
- Check that the electric brakes work by operating the brake controller inside the tow vehicle

## Trailer Towing Tips

Driving a vehicle with a trailer in tow is vastly different from driving the same vehicle without a trailer in tow. Acceleration, maneuverability and braking are all diminished with a trailer in tow.

It takes longer to get up to speed, you need more room to turn and pass, and more distance to stop when towing a trailer. You will need to spend time adjusting to the different feel and maneuverability of the tow vehicle with a loaded trailer.

Because of the significant differences in all aspects of maneuverability when towing a trailer, the hazards and risks of injury are also much greater than when driving without a trailer. You are responsible for keeping your vehicle and trailer in control, and for all the damage that is caused if you lose control of your vehicle and trailer.

As you did when learning to drive an automobile, find an open area with little or no traffic for your first practice trailering. Of course, before you start towing the trailer, you must follow all of the instructions for inspection, testing, loading and coupling. Also, before you start towing, adjust the mirrors so you can see the trailer as well as the area to the rear of it.

Drive slowly at first, 5 m.p.h. or so, and turn the wheel to get the feel of how the tow vehicle and trailer combination responds. Next, make some right and left hand turns. Watch in your side mirrors to see how the trailer follows the tow vehicle. Turning with a trailer attached requires more room.

Stop the rig a few times from speeds no greater than 10 m.p.h. If your trailer is equipped with brakes, try using different combinations of trailer/electric brake and tow vehicle brake. Note the effect that the trailer brakes have when they are the only brakes used. When properly adjusted, the trailer brakes will come on just before the tow vehicle brakes.

It will take practice to learn how to back up a tow vehicle with a trailer attached. Take it slow. Before backing up, get out of the tow vehicle and look behind the trailer to make sure that there are no obstacles.

# TRAILER SAFETY GUIDELINES

Some drivers place their hands at the bottom of the steering wheel, and while the tow vehicle is in reverse, “think” of the hands as being on the top of the wheel. When the hands move to the right (counter-clockwise, as you would do to turn the tow vehicle to the left when moving forward), the rear of the trailer moves to the right. Conversely, rotating the steering wheel clockwise with your hands at the bottom of the wheel will move the rear of the trailer to the left while backing up.

If you are towing a bumper hitch rig, be careful not to allow the trailer to turn too much, because it will hit the rear of the tow vehicle. To straighten the rig, either pull forward or turn the steering wheel in the opposite direction.

## Trailer VIN Tag

Figure 25 below is a sample of the Vehicle Identification Number (VIN) Tag which is located on the left front of the trailer. See Figure 26.

|   |                                |               |   |
|---|--------------------------------|---------------|---|
| MANUFACTURED BY / FABRIQUE PAR:   |                                | DATE          |   |
| GVWR / PNBV   | KG ( LB)                       |               |   |
| GAWR (EACH AXLE) / PNBE (CHAQUE ESSIEU)   | KG ( LB)                       | TIRES / PNEUS |   |
| RIMS / JANTS  |                                |               |   |
| COLD INFL. PRESS. / PRESS. DE GONFL. A FROID  | KPA (                          | PSI / LPO     | <input type="checkbox"/> SINGLE <input type="checkbox"/> DUAL |
| <small>THIS VEHICLE CONFORMS TO ALL APPLICABLE U.S. FEDERAL MOTOR VEHICLE SAFETY STANDARDS IN EFFECT ON THE DATE OF MANUFACTURE SHOWN ABOVE.<br/>THIS VEHICLE CONFORMS TO ALL APPLICABLE STANDARDS PRESCRIBED UNDER THE CANADIAN MOTOR VEHICLE SAFETY REGULATIONS IN EFFECT ON THE DATE OF MANUFACTURE. - CE VEHICULE EST CONFORME A TOUTES LES NORMES QUI LUI SONT APPLICABLES EN VERTU DU REGLEMENT SUR LA SECURITE DES VEHICULES AUTOMOBILES DU CANADA EN VIGUEUR A LA DATE DE SA FABRICATION.</small> |                                |               |   |
| V.I.N. / N.L.V.:  | TYPE / TYPE: TRAILER TRA / REM |               | FD-306 REV A  |

Figure 25. Vehicle VIN Tag

The trailer **VIN Tag** contains the following critical safety information for the use of your trailer.

**GAWR:** The maximum gross weight that an axle can support. It is the lowest of axle, wheel, or tire rating. Usually, the tire or wheel rating is lower than the axle rating, and determines GAWR.

**GVWR:** The maximum allowable gross weight of the trailer and its contents. The gross weight of the trailer includes the weight of the trailer and all of the items within it (such as the pump with water, engine, and other ITEMS). GVWR is sometimes referred to as GTWR (Gross Trailer Weight Rating), or MGTW (Maximum Gross Trailer Weight). GVWR, GTWR and MGTW are all the same rating.

The sum total of the GAWR for all trailer axles may be less than the GVWR for the trailer, because some of the trailer load is to be carried by the tow vehicle, rather than by the trailer axle(s). The total weight of the cargo and trailer must not exceed the GVWR, and the load on an axle must not exceed its GAWR.

**PSIC:** The tire pressure (Pounds per Square Inch) measured when Cold.

**VIN:** The Vehicle Identification Number.

**EMPTY WEIGHT:** Some information that comes with the trailer (such as the Manufacturer’s Statement of Origin) is not a reliable source for “empty” or “net” weight. The shipping documents list average or standard weights and your trailer may be equipped with options.

To determine the “empty” or “net” weight of your trailer, weigh it on an axle scale. To find the weight of the trailer using an axle scale, you must know the axle weights of your tow vehicle **without** the trailer coupled. Some of the trailer weight will be transferred from the trailer to the tow vehicle axles, and an axle scale weighs all axles, including the tow vehicle axles.

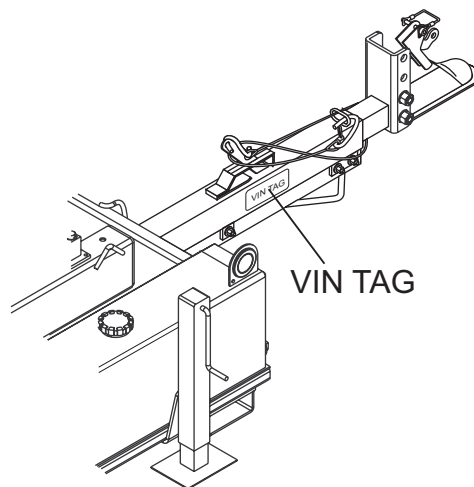

Figure 26. VIN Tag Location

## Tow Vehicle

The towing hitch attached to your tow vehicle must have a capacity equal to or greater than the load rating of the trailer you intend to tow. The hitch capacity must also be matched to the tow vehicle capacity. Your vehicle dealer can provide and install the proper hitch on your tow vehicle.

## Suspension System

Sway bars, shock absorbers, heavy duty springs, heavy duty tires and other suspension components may be required to sufficiently tow the Dry Prime trailer and pump.

## Brake Controller

For trailers equipped with electric brakes, the electric brake controller is part of the tow vehicle and is essential in the operation of the electric brakes on the trailer. The brake controller is not the same as the safety breakaway brake system that may be equipped on the trailer.

## Side View Mirrors

The size of the trailer that is being towed and your state law regulations determine the size of the mirrors. However, some states prohibit extended mirrors on a tow vehicle, except while a trailer is actually being towed. In this situation, detachable extended mirrors are necessary. Check with your dealer or the appropriate state agency for mirror requirements.

## Heavy Duty Flasher

A Heavy Duty Flasher is an electrical component that may be required when your trailer turn signal lights are attached to the tow vehicle flasher circuit.

## Electrical Connector

An Electrical Connector connects the light and brake systems on the trailer to the light and brake controls on the towing vehicle.

## Emergency Flares and Emergency Triangle Reflectors

It is wise to carry these warning devices even if you are not towing a trailer. It is particularly important to have these when towing a trailer because the hazard flashers of your towing vehicle will not operate for as long a period of time when the battery is running both the trailer lights and tow vehicle lights.

## Safety Chains

If the coupler connection comes loose, the safety chains can keep the trailer attached to the tow vehicle. With properly rigged safety chains, it is possible to keep the tongue of the trailer from digging into the road pavement, even if the coupler-to-hitch connection comes apart.

Trailer Lighting (and Braking) Connector.

A device that connects electrical power from the tow vehicle to the trailer. Electricity is used to turn on brake lights, running lights, and turn signals as required. In addition, if your trailer has a separate braking system, the electrical connector will also supply power to the brakes from the tow vehicle.

## Breakaway System

If the trailer coupler connection comes loose, the breakaway system can actuate emergency electric or surge brakes depending on the type of actuator on the trailer. The breakaway cable must be rigged to the tow vehicle with appropriate slack that will activate the system if the coupler connection comes loose.

## Jackstand

A device on the trailer that is used to raise and lower the coupler. The jack is sometimes called the "landing gear" or the "tongue jack".

## WARNING

An improperly coupled trailer can result in death or serious injury.

**DO NOT** move the trailer until:

- The coupler is secured and locked to hitch;
- The safety chains are secured to the tow vehicle
- The trailer jack(s) are fully retracted.

**DO NOT** tow the trailer on the road until:

- Tires and wheels are checked;
- The trailer brakes are checked;
- The breakaway switch is connected to the tow vehicle;
- The load is secured to the trailer
- The trailer lights are connected and checked.

## Coupler Types

The Dry Prime pump is shipped from the factory with a 2-5/16-inch ball coupler. A pintle eye coupler can be purchased as an alternative method (option) for towing. Both types of couplers will be discussed in this manual.

- Ball Hitch Coupler
- Pintle Eye Coupler

## Ball Hitch Coupler

A ball hitch coupler (Figure 27) connects to a ball that is located on or under the rear bumper of tow vehicle. This system of coupling a trailer to a tow vehicle is sometimes referred to as “bumper pull.”

A ball hitch trailer may be fitted with a tongue jack that can raise and lower the coupler. The tongue jack is mounted to the A-frame (front, or tongue) part of the trailer. By rotating the jack handle clockwise, the jack will extend and raise the tongue of the trailer.

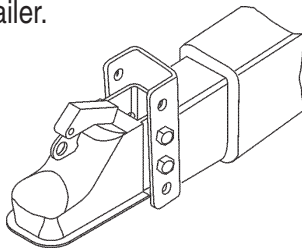

**Figure 27. Ball Hitch Coupler Adjustable Tongue**

Before each tow, coat the ball with a thin layer of automotive bearing grease to reduce wear and ensure proper operation; and check the locking device that secures the coupler to the ball for proper operation.

If you see or feel evidence of wear, such as flat spots, deformations, pitting or corrosion, on the ball or coupler, immediately have your dealer inspect them to determine the proper action to prevent possible failure of the ball and coupler system. All bent or broken coupler parts must be replaced before towing the trailer.

The coupler handle lever must be able to rotate freely and automatically snap into the latched position. Oil the pivot points, sliding surfaces, and spring ends with SAE 30W motor oil. Keep the ball socket and latch mechanism clean. Dirt or contamination can prevent proper operation of the latching mechanism.

The load rating of the coupler and the necessary ball size are listed on the trailer tongue. You must provide a hitch and ball for your tow vehicle where the load rating of the hitch and ball is equal to or greater than that of your trailer.

Also, the ball size must be the same as the coupler size. If the hitch ball is too small, too large, is underrated, is loose or is worn, the trailer can come loose from the tow vehicle and may cause death or serious injury.

**THE TOW VEHICLE, HITCH AND BALL MUST HAVE A RATED TOWING CAPACITY EQUAL TO OR GREATER THAN THE TRAILER Gross Vehicle Weight Rating (GVWR). IT IS ESSENTIAL THAT THE HITCH BALL BE OF THE SAME SIZE AS THE COUPLER.**

The ball size and load rating (capacity) are marked on the ball; hitch capacity is marked on the hitch.

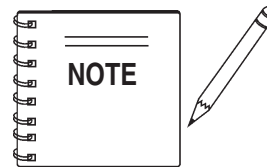

When replacing a ball, the load rating must match or exceed the GVWR of the trailer.

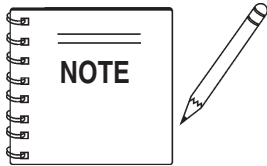

Before coupling the tow vehicle to the trailer, be sure the size and rating of hitch ball match the size and rating of the coupler. Hitch balls and couplers are marked with their size and rating.

## **! WARNING - Hitch Ball Load Rating**

Coupler-to-hitch mismatch can result in uncoupling, leading to death or serious injury.

Be sure the **LOAD RATING** of the hitch ball is equal or greater than the load rating of the coupler.

Be sure the **SIZE** of the hitch ball matches the size of the ball coupler.



# TRAILER SAFETY GUIDELINES

## WARNING - Defective Hitch Ball

A worn, cracked or corroded hitch ball can fail while towing, and may result in death or serious injury.

Before coupling trailer, inspect the hitch ball for wear, corrosion and cracks.

Replace worn or damaged hitch ball.

## WARNING - Uncoupled Hitch Ball

A loose hitchball nut can result in uncoupling, leading to death or serious injury.

Be sure the hitch ball is tight to the hitch before coupling the trailer.

- Rock the ball to make sure it is tighten to the hitch, and visually check that the hitch ball nut is solid against the lock washer and hitch frame.
- Wipe the inside and outside of the coupler, clean and inspect it visually for cracks and deformations; feel the inside of the coupler for worn spots and pits.
- Be sure the coupler is secured tightly to the tongue of the trailer. All coupler fasteners must be visibly solid against the trailer frame.
- The bottom surface of the coupler to be above the top of the hitch ball. Use the tongue jackstand to support the trailer tongue. Wood or concrete blocks may also be used.

### Coupling the Trailer to the Tow Vehicle (Ball Coupler)

- Lubricate the hitch ball and the inside of the coupler with a thin layer of automotive bearing grease.
- Slowly back up the tow vehicle so that the hitch ball is near or aligned under the coupler.
- Using the jackstand at the front of trailer (tongue), turn the jackstand crank handle to raise the trailer. If the ball coupler does not line up with the hitch ball, adjust the position of the tow vehicle.
- Open the coupler locking mechanism. Ball couplers have a locking mechanism with an internal moving piece and an outside handle. In the open position, the coupler is able to drop fully onto the hitch ball.

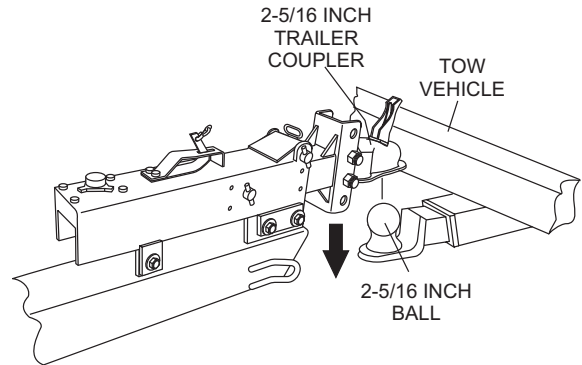
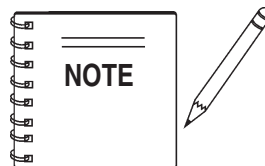

Figure 28. Ball Hitch Coupling Mechanism

- Lower the trailer (Figure 28) until the coupler fully engages the hitch ball.
- Engage the coupler locking mechanism. In the engaged position, the locking mechanism securely holds the coupler to the hitch ball.
- Insert a pin or lock through the hole in the locking mechanism.
- Be sure the coupler is all the way on the hitch ball and the locking mechanism is engaged. A properly engaged locking mechanism will allow the coupler to raise the rear of the tow vehicle. Using the trailer jackstand, verify that you can raise the rear of the tow vehicle by 1-inch after the coupler is locked to the hitch.
- Lower the trailer so that its entire tongue weight is held by the hitch.
- Raise the jackstand to a height where it will not interfere with the road.



Overloading can damage the tongue jack. **DO NOT** use the tongue jack to raise the tow vehicle more than 1 inch.

**If the coupler cannot be secured to the hitch ball, do not tow the trailer.** Call your dealer for assistance. Lower the trailer so that its entire tongue weight is held by the hitch, and continue retracting the jack to its fully retracted position.

# TRAILER SAFETY GUIDELINES

## Attaching Safety Chain

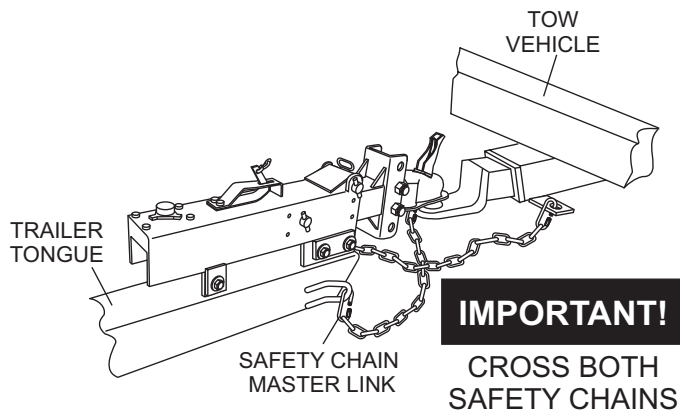

**Figure 29. Safety Chain Arrangement for a Bumper Pull Trailer (Ball Hitch)**

- Visually inspect the safety chains and hooks for wear or damage. Replace worn or damaged safety chains and hooks before towing.
- Attach the safety chains so that they:
  - A. Cross underneath the coupler. See Figure 29.
  - B. Loop around a frame member of the tow vehicle or holes provided in the hitch system (but, **DO NOT** attach them to an interchangeable part of the hitch assembly).
  - C. Have enough slack to permit tight turns, but not be close to the road surface, so if the trailer uncouples, the safety chains can hold the tongue up above the road.

### **! WARNING - Safety Chains Rigging**

Improper rigging of the safety chains can result in loss of control of the trailer and tow vehicle, leading to death or serious injury, if the trailer uncouples from the tow vehicle.

- Fasten chains to frame of tow vehicle. **DO NOT** fasten chains to any part of the hitch unless the hitch has holes or loops specifically for that purpose.
- ***Cross chains underneath*** hitch and coupler with enough slack to permit turning and to hold tongue up, if the trailer comes loose.

## Breakaway Brake System

If the coupler or hitch fails, a properly connected and working breakaway brake system (Figure 30) will apply the hydraulic and/or electric brakes on the trailer. The safety chains will keep the tow vehicle attached and as the brakes are applied at the trailer's axles, the trailer/tow vehicle combination will come to a controlled stop.

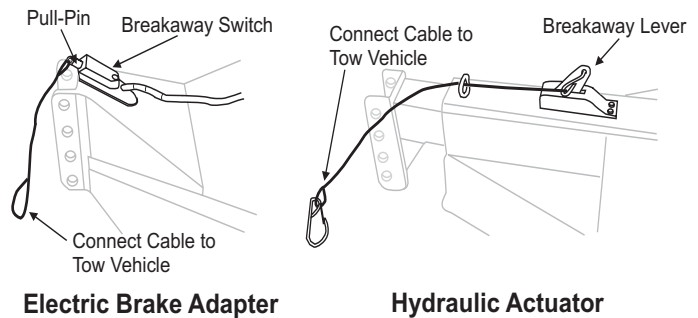

**Figure 30. Breakaway Brake Systems**

## Breakaway Cable Surge Brake System

For Dry Prime pump trailers equipped with hydraulic surge brakes, the breakaway brake system includes a brake cable connected to the tow vehicle on one end and to the emergency brake lever located on the hydraulic actuator on the other end.

## Breakaway Electric Braking System

For Dry Prime pump trailers equipped with an electric braking system, the electric breakaway brake system includes a DC power source, a switch with a pull pin, and a breakaway brake controller. You must periodically charge the battery to keep the breakaway brake system in working order.

### **! WARNING - Brakeaway Cable**

An ineffective breakaway brake system can result in a runaway trailer, leading to death or serious injury, if the coupler or ball hitch fails.

Connect the breakaway cable to the tow vehicle; and **NOT** to the hitch, ball or support.

Before towing the trailer, test the function of the breakaway brake system. If the breakaway brake system is not working, **DO NOT** tow the trailer. Have it serviced or repaired.

# TRAILER SAFETY GUIDELINES

## Electric Brake Testing

Perform the following when testing the electric braking system:

- Connect the pull pin cable to the tow vehicle so that the pull pin will be pulled out before all of the slack in the safety chains is taken up (see Figure 30). **DO NOT** connect the pullpin cable to a safety chain or to the hitch ball or hitch ball assembly. This would keep the breakaway brake system from operating when it is needed.
- When electric brakes are used, the tow vehicle will have an electric brake controller that sends power to the trailer brakes. Before towing the trailer on the road, you must operate the brake controller while trying to pull the trailer in order to confirm that the electric brakes operate. Remove the pullpin from the switch. While towing the trailer at less than 5 m.p.h., manually operate the electric brake controller in the tow vehicle cab.  
  
You should feel the trailer resisting being towed, but the wheels will not necessarily be locked. If the brakes do not function, **DO NOT** tow the trailer until brakes are repaired.
- Immediately replace the pullpin. The breakaway brake system battery discharges rapidly when the pullpin is removed.

### **WARNING - Pullpin Replacement**

Failure to replace the pullpin will prevent brakes from working, leading to loss of control, serious injury or death.

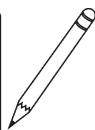
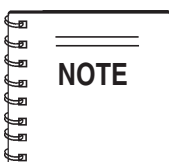

**DO NOT** tow the trailer with the breakaway brake system **ON** because the brakes will overheat which can result in permanent brake failure.

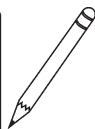
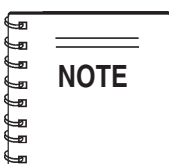

Replace the breakaway brake battery (if equipped) according to the battery at intervals specified by manufacturer.

## Connecting Trailer Lights

Connect the trailer lights to the tow vehicle's electrical system using the electric connectors at the front of the trailer (tongue). Reference the wiring diagram shown in the trailer wiring diagram section of this manual. Before towing the trailer check for the following:

- Running lights (turn on tow vehicle headlights).
- Brake Lights (step on tow vehicle brake pedal).
- Backup Lights (place tow vehicle gear shift in reverse).
- Turn Signals (activate tow vehicle directional signal lever).

### **WARNING - Improper Electrical Connections**

Improper electrical connection between the tow vehicle and the trailer will result in inoperable lights and electric brakes, and can lead to collision.

Before each tow:

- Check that the taillights, brake lights and turn signals work
- Check that the electric brakes work by operating the brake controller inside the tow vehicle.

## Uncoupling the Ball Hitch

Follow these steps to uncouple ball hitch from tow vehicle:

- Block trailer tires to prevent the trailer from rolling, before jacking the trailer up.
- Disconnect the electrical connector.
- Disconnect the breakaway brake switch cable. Promptly replace the pullpin in the switchbox.
- Before extending jackstand, make certain the ground surface below the jackstand foot will support the tongue load.
- Rotate the jackstand handle (or crank) clockwise. This will slowly extend the jack and transfer the weight of the trailer tongue to the jack.

# TRAILER SAFETY GUIDELINES

## Pintle Hitch Coupler

A pintle eye coupler (Figure 31) connects to a pintle-hook hitch that is located on or under the rear bumper of the tow vehicle. This system of coupling a trailer to a tow vehicle is sometimes referred to as a “lunette eye, tow ring or G.I. hitch.”

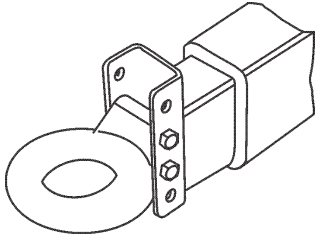

**Figure 31. Pintle Hitch Coupler Adjustable Tongue**

A pintle hitch trailer may be fitted with a tongue jackstand that can raise and lower the coupler. The tongue jack is mounted to the A-frame (front, or tongue) part of the trailer. By rotating the jack handle clockwise, the jack will extend and raise the tongue of the trailer.

The load rating of the coupler and the necessary pintle hitch size are listed on the trailer tongue. You must provide a pintle hitch and pintle coupler for your tow vehicle, where the load rating of the pintle hitch and pintle coupler is equal to or greater than that of your trailer.

Also, the pintle hitch size must be the same as the pintle coupler size. If the hitch is too small, too large, is underrated, is loose or is worn, the trailer can come loose from the tow vehicle, and may cause death or serious injury.

## Pintle Coupler and Pintle Hook

Before each tow, check the locking device that secures the coupler to the pintle hook assembly.

The pintle hook lever must be able to operate freely and automatically snap into place into the latched position. Lightly oil the pivot points and sliding surfaces with SAE30W motor oil to prevent rust and help ensure proper operation of the latching mechanism.

If you see or feel evidence of wear, such as flat spots, deformations, pitting or corrosion, on the pintle hook or coupler, immediately have your dealer inspect them to determine the proper action to prevent possible failure of the ball and coupler system. All bent or broken coupler parts must be replaced before towing the trailer.

**THE TOW VEHICLE, PINTLE HITCH AND PINTLE COUPLER MUST HAVE A RATED TOWING CAPACITY EQUAL TO OR GREATER THAN THE TRAILER Gross Vehicle Weight Rating (GVWR).**

**IT IS ESSENTIAL THAT THE PINTLE HITCH BE OF THE SAME SIZE AS THE PINTLE COUPLER.**

The coupler size and load rating (capacity) are marked on the coupler; hitch capacity is marked on the hitch.

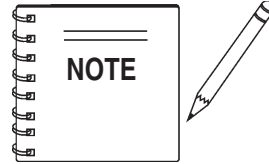

Before coupling the tow vehicle to the trailer, be sure the size and rating of the pintle-hook hitch match the size and rating of the pintle eye coupler. Pintle-hook hitches and couplers are marked with their size and rating.

### **! WARNING - Hitch Ball Load Rating**

Coupler-to-hitch mismatch can result in uncoupling, leading to death or serious injury.

Be sure the **LOAD RATING** of the pintle hitch hook is equal or greater than the load rating of the pintle eye coupler.

Be sure the **SIZE** of the pintle hitch hook matches the size of the pintle eye coupler.

### **! WARNING - Defective Pintle Hitch Hook**

A worn, cracked or corroded pintle hitch hook can fail while towing, and may result in death or serious injury.

Before coupling trailer, inspect the pintle hitch hook for wear, corrosion and cracks.

Replace worn or damaged pintle hitch hook.

- Rock the pintle eye coupler to make sure it is secured tightly to the hitch.
- Wipe the inside and outside of the pintle coupler, clean and inspect it visually for cracks and deformations; feel the inside of the coupler for worn spots and pits.
- Be sure the coupler is secured tightly to the tongue of the trailer. All coupler fasteners must be visibly solid against the trailer frame.
- Raise the bottom surface of the coupler to be above the top of the pintle hitch hook. Use the tongue jackstand to support the trailer tongue. Wood or concrete blocks may also be used.

## **! WARNING - Uncoupled Pintle Hitch Hook**

A defective pintle hitch not properly fastened can result in uncoupling, leading to death or serious injury.

Be sure the pintle hook is securely tightened to the tow vehicle before coupling the trailer.

### **Coupling the Trailer to the Tow Vehicle (Pintle Coupler)**

- Slowly back up the tow vehicle so that the pintle hitch hook is near or aligned under the pintle eye ring coupler.
- Using the jackstand at the front of trailer (tongue), turn the jackstand crank handle to raise the trailer. If the pintle eye coupler does not line up with the pintle hitch hook, adjust the position of the tow vehicle.
- **OPEN** the pintle hook locking mechanism (Figure 32). Place the hook inside the eye coupler. **CLOSE** the pintle hook mechanism.

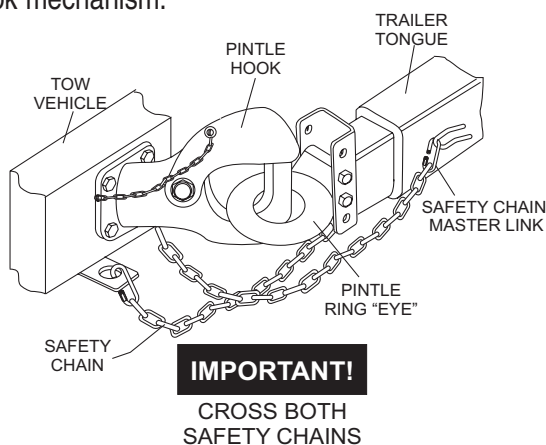

**Figure 32. Safety Chain Arrangement for a Bumper Pull Trailer (Pintle Hitch)**

- Insert a pin or lock through the hole in the locking mechanism.
- Be sure the pintle hook is inserted completely through the eye ring and the locking mechanism is engaged. A properly engaged locking mechanism will allow the coupler to raise the rear of the tow vehicle. Using the trailer jack, test to see that you can raise the rear of the tow vehicle by 1-inch after the coupler is locked to the hitch.
- Lower the trailer so that its entire tongue weight is held by the hitch.
- Raise the jackstand to a height where it will not interfere with the road.

## **TIRE SAFETY**

### **Unsafe Tires, Lug Nuts or Wheels**

Trailer tires and wheels are more likely to fail than car tires and wheels because they carry a heavier load. Therefore, it is essential to inspect the trailer tires before each tow.

If a tire has a bald spot, bulge, cuts, is showing any cords, or is cracked, replace the tire before towing. If a tire has uneven tread wear, take the trailer to a dealer service center for diagnosis.

Uneven tread wear can be caused by tire imbalance, axle misalignment or incorrect inflation.

Tires with too little tread will not provide adequate tracking on wet roadways and can result in loss of control, leading to death or serious injury.

Improper tire pressure causes an unstable trailer and can result in a tire blowout and loss of control. Therefore, before each tow you must also check the tire pressure. Tire pressure must be checked when tires are cold.

Allow 3 hours cool-down after driving as much as 1 mile at 40 m.p.h. before checking tire pressure. **NOTE:** Trailer tires will be inflated to higher pressures than passenger vehicle tires.

Since trailer wheels and lug nuts (or bolts) are subjected to greater side loads than automobile wheels, they are more prone to loosen. Before each tow, check to make sure they are tight.

The proper tightness (torque) for lug nuts is listed in the lug nut tightening section of this manual. Use a torque wrench to tighten the lug nuts. If you do not have a torque wrench, use a lug wrench (from your tow vehicle) and tighten the nuts as much as you can. Then have a service garage or trailer dealer tighten the lug nuts to the proper torque.

## **! WARNING - Lug Nut Tightening**

Metal creep between the wheel rim and lug nuts will cause rim to loosen and could result in a wheel coming off, leading to death or serious injury.

Tighten lug nuts before each tow.

Lug nuts are also prone to loosen after first being assembled. When driving a new trailer (or after wheels have been remounted), check to make sure they are tight after the **first** 10, 25 and 50 miles of driving and before each tow thereafter.

Failure to perform this check can result in a wheel parting from the trailer and a crash, leading to death or serious injury.

**! WARNING - Lug Nut Loosening**

Lug nuts are prone to loosen after initial installation, which can lead to death or serious injury.

Check lug nuts for tightness on a new trailer or when wheel(s) have been remounted after the first 10, 25 and 50 miles of driving.

**! WARNING - Improper Lug Nut Torque**

Improper lug nut torque can cause a wheel parting from the trailer, leading to death or serious injury.

Be sure lug nuts are tight before each tow.

**! WARNING - Tire Pressure**

Improper tire pressure can result in a blowout and loss of control, which can lead to death or serious injury.

Be sure tires are inflated to pressure indicated on side wall before towing trailer.

## Determining Load Limit of Trailer

Determining the load limits of a trailer includes more than understanding the load limits of the tires alone. On all trailers there is a Federal certification/VIN label that is located on the forward half of the left (road) side of the unit. This certification/VIN label will indicate the trailer's Gross Vehicle Weight Rating (GVWR). This is the most weight the fully loaded trailer can weigh. It will also provide the Gross Axle Weight Rating (GAWR). This is the most a the axle can weigh.

There is a vehicle placard (Figure 33) located in the same location as the certification label described above. This placard provides tire and loading information. In addition, this placard will show a statement regarding maximum cargo capacity.

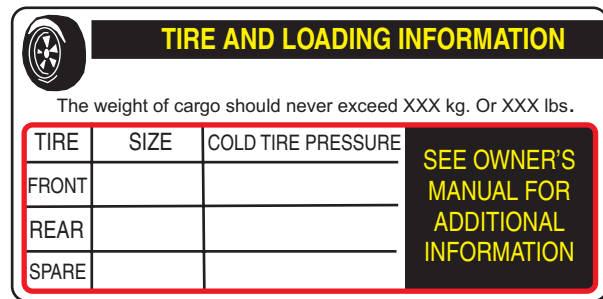

**Figure 33. Tire and Loading Information Placard**

If additional work items (hoses, tools, clamps etc.) are going to be added to the trailer, be sure they are distributed evenly to prevent overloading front to back and side to side. Heavy items should be placed low and as close to the axle positions as reasonable. Too many items on one side may overload a tire.

Excessive loads and/or underinflation cause tire overloading and, as a result, abnormal tire flexing occurs. This situation can generate an excessive amount of heat within the tire. Excessive heat may lead to tire failure. It is the air pressure that enables a tire to support the load, so proper inflation is critical. The proper air pressure may be found on the certification/VIN label and/or on the Tire and Loading Information placard. This value should never exceed the maximum cold inflation pressure stamped on the tire.

## Step 1.

Locate the statement, "The weight of cargo should never exceed XXX kg or XXX lbs.," on your vehicle's Tire and Loading Information placard (Figure XX). This figure equals the available amount of equipment load capacity.

## Step 2.

Determine the weight of the equipment being loaded on the tow vehicle. That weight may not safely exceed the available equipment load capacity. The trailer's Tire Information Placard is attached adjacent to or near the trailer's VIN (Certification) label at the left front of the trailer (See Figure 33).

## Determining Load Limit of Tow Vehicle

### Step 1.

Locate the statement, "The combined weight of occupants and cargo should never exceed XXX lbs.," on your vehicle's placard.

### Step 2.

Determine the combined weight of the driver and passengers who will be riding in your vehicle.

### Step 3.

Subtract the combined weight of the driver and passengers from XXX kilograms or XXX pounds.

### Step 4.

The resulting figure equals the available amount of cargo and luggage capacity. For example, if the "XXX" amount equals 1400 lbs. and there will be five 150 lb. passengers in your vehicle, the amount of available cargo and luggage capacity is 650 lbs. (1400-750 (5 x 150) = 650 lbs.).

### Step 5.

Determine the combined weight of luggage and cargo being loaded on the vehicle. That weight may not safely exceed the available cargo and luggage capacity calculated in Step 4.

If your vehicle will be towing a trailer, load from your trailer will be transferred to your vehicle. Consult the tow vehicle's manual to determine how this weight transfer reduces the available cargo and luggage capacity of your vehicle.

Studies of tire safety show that maintaining proper tire pressure, observing tire and vehicle load limits (not carrying more weight in your vehicle than your tires or vehicle can safely handle), avoiding road hazards and inspecting tires for cuts, slashes and other irregularities are the most important things you can do to avoid tire failure, such as tread separation or blowout and flat tires. These actions, along with other care and maintenance activities, can also:

- Improve vehicle handling
- Help protect you and others from avoidable breakdowns and accidents.
- Improve fuel economy
- Increase the tire life

Use the information contained in this section to make tire safety a regular part of your vehicle maintenance routine. Recognize that the time you spend is minimal compared with the inconvenience and safety consequences of a flat tire or other tire failure.

## Tire Fundamentals

Federal law requires tire manufacturers to place standardized information on the sidewall of all tires (Figure 34). This information identifies and describes the fundamental characteristics of the tire and also provides a tire identification number for safety standard certification and in case of a recall.

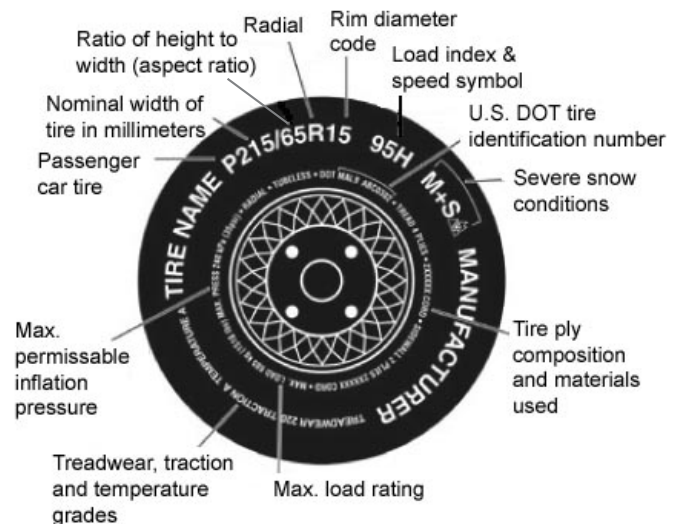

Figure 34. Standard Tire Sidewall Information

**P:** The “P” indicates the tire is for passenger vehicles.

**Next number:** This three-digit number gives the width in millimeters of the tire from sidewall edge to sidewall edge. In general, the larger the number, the wider the tire.

**Next number:** This two-digit number, known as the aspect ratio, gives the tire’s ratio of height to width. Numbers of 70 or lower indicate a short sidewall for improved steering response and better overall handling on dry pavement.

**P:** The “R” stands for radial. Radial ply construction of tires has been the industry standard for the past 20 years.

**Next number:** This two-digit number is the wheel or rim diameter in inches. If you change your wheel size, you will have to purchase new tires to match the new wheel diameter.

**Next number:** This two- or three-digit number is the tire’s load index. It is a measurement of how much weight each tire can support. You may find this information in your owner’s manual. If not, contact a local tire dealer. Note: You may not find this information on all tires because it is not required by law.

**M+S:** The “M+S” or “M/S” indicates that the tire has some mud and snow capability. Most radial tires have these markings; hence, they have some mud and snow capability.

**Speed Rating:** The speed rating denotes the speed at which a tire is designed to be driven for extended periods of time. The ratings range from 99 miles per hour (mph) to 186 mph. These ratings are listed in Table 7. Note: You may not find this information on all tires because it is not required by law.

| <b>Letter Rating</b> | <b>Speed Rating</b> |
|----------------------|---------------------|
| Q                    | 99 mph              |
| R                    | 106 mph             |
| S                    | 112 mph             |
| T                    | 118 mph             |
| U                    | 124 mph             |
| H                    | 130 mph             |
| V                    | 149 mph             |
| W                    | 168* mph            |
| Y                    | 186* mph            |

**U.S. DOT Tire Identification Number:** This begins with the letters “DOT” and indicates that the tire meets all federal standards. The next two numbers or letters are the plant code where it was manufactured, and the last four numbers represent the week and year the tire was built. For example, the numbers 3197 means the 31st week of 1997. The other numbers are marketing codes used at the manufacturer’s discretion. This information is used to contact consumers if a tire defect requires a recall.

**Tire Ply Composition and Materials Used:** The number of plies indicates the number of layers of rubber-coated fabric in the tire. In general, the greater the number of plies, the more weight a tire can support. Tire manufacturers also must indicate the materials in the tire, which include steel, nylon, polyester, and others.

**Maximum Load Rating:** This number indicates the maximum load in kilograms and pounds that can be carried by the tire.

**Maximum Permissible Inflation Pressure:** This number is the greatest amount of air pressure that should ever be put in the tire under normal driving conditions.

### **Uniform Tire Quality Grading Standards (UTQGS)**

**Treadwear Number:** This number indicates the tire’s wear rate. The higher the treadwear number is, the longer it should take for the tread to wear down. For example, a tire graded 400 should last twice as long as a tire graded 200.

**Traction Letter:** This letter indicates a tire’s ability to stop on wet pavement. A higher graded tire should allow you to stop your car on wet roads in a shorter distance than a tire with a lower grade. Traction is graded from highest to lowest as “AA”, “A”, “B”, and “C”.

**Temperature Letter:** This letter indicates a tire’s resistance to heat. The temperature grade is for a tire that is inflated properly and not overloaded. Excessive speed, underinflation or excessive loading, either separately or in combination, can cause heat build-up and possible tire failure. From highest to lowest, a tire’s resistance to heat is graded as “A”, “B”, or “C”.



Reference Figure 35 for additional tire information for light trucks.

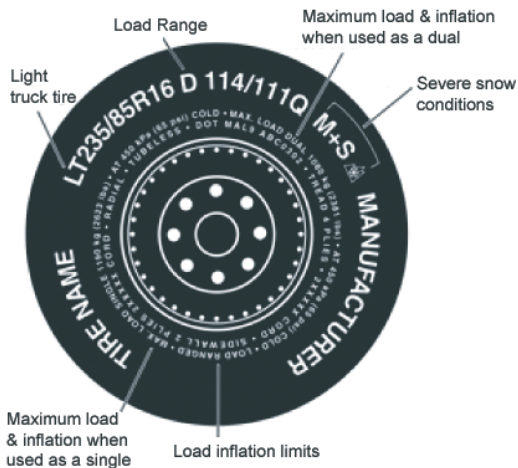

**Figure 35. UTQGS Tire Information**

Tires for light trucks have other markings besides those found on the sidewalls of passenger tires.

**LT:** The “LT” indicates the tire is for light trucks or trailers.

**ST:** An “ST” is an indication the tire is for trailer use only.

**Max. Load Dual** kg (lbs) at kPa (psi) Cold: This information indicates the maximum load and tire pressure when the tire is used as a dual, that is, when four tires are put on each rear axle (a total of six or more tires on the vehicle).

**Max. Load Single** kg (lbs) at kPa (psi) Cold

This information indicates the maximum load and tire pressure when the tire is used as a single.

### Load Range

This information identifies the tire’s load-carrying capabilities and its inflation limits.

### Tire Safety Tips

- Slow down if you have to go over a pothole or other object in the road.
- **DO NOT** run over curbs or other foreign objects in the roadway, and try not to strike the curb when parking.
- Check tire inflation pressure weekly during use to insure the maximum tire life and tread wear.
- **DO NOT** bleed air from tires when they are hot.
- Inspect tires for uneven wear patterns on the tread, cracks, foreign objects, or other signs of wear or trauma.
- Remove bits of glass and foreign objects wedged in the tread.

- Make sure your tire valves have valve caps.
- **ALWAYS** check tire pressure on tow vehicle and trailer before towing. Check tire pressure at least once a month.
- **DO NOT** overload tow vehicle. Check the tire information and loading placard for safe allowable tire loading conditions.







### Tire Repair

The proper repair of a punctured tire requires a plug for the hole and a patch for the area inside the tire that surrounds the puncture hole. Punctures through the tread can be repaired if they are not too large, but punctures to the sidewall **should not be repaired**. Tires must be removed from the rim to be properly inspected before being plugged and patched.

### Replacing Worn or Damaged Tires

Replace the tire before towing the trailer if the tire treads have less than 1/16 inch depth or the telltale bands are visible. Check inflation pressure weekly during use to insure the maximum tire life and tread wear. A bubble, cut or bulge in a side wall can result in a tire blowout. Inspect both side walls of each tire for any bubble, cut or bulge; and replace a damaged tire before towing the trailer.

Table 8 below will help pinpoint the causes and solutions of tire wear problems.

| TABLE 8 TIRE WEAR TROUBLESHOOTING   |                                 |   |  |
|---|---------------------------------|---|--|
| WEAR PATTERN  | CAUSE                           | SOLUTION  |  |
|  Center Wear | Over Inflation                  | Adjust pressure to particular load per tire manufacturer. |  |
|  Edge Wear   | Under Inflation                 | Adjust pressure to particular load per tire manufacturer. |  |
|  Side Wear   | Loss of chamber or overloading. | Make sure load does not exceed axle rating. Align wheels. |  |
|  Toe Wear    | Incorrect toe-in                | Align wheels.   |  |
|  Cupping     | Out-of balance                  | Check bearing adjustment and balance tires.               |  |
|  Flat Spots  | Wheel lockup & tire skidding.   | Avoid sudden stops when possible and adjust brakes.       |  |

## WARNING - Flying Objects

**ALWAYS** wear safety glasses when removing or installing force fitted parts **DO NOT** attempt to repair or modify a wheel. **DO NOT** install an inner-tube to correct a leak through the rim. If the rim is cracked, the air pressure in the inner tube may cause pieces of the rim to explode (break off) with great force and cause serious eye or bodily injury.



## Wheel Rims

If the trailer has been struck, or impacted, on or near the wheels, or if the trailer has struck a curb, inspect the rims for damage (i.e. being out of round); and replace any damaged wheel. Inspect the wheels for damage every year, even if no obvious impact has occurred.

## Wheels, Bearings and Lug Nuts

A loose, worn or damaged wheel bearing is the most common cause of brakes that grab.

To check wheel bearings, jack trailer and check wheels for side-to-side looseness. If the wheels are loose, or spin with a wobble, the bearings must be serviced or replaced. Check inflation pressure weekly during use to insure the maximum tire life and tread wear. Most trailer axles are built with sealed bearings that are not serviceable. Sealed bearings must be replaced as complete units.

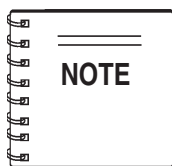

**NEVER!** use an pneumatic air gun to tighten wheel lug nuts.

## WARNING - Lug Nut Tightening

Over-tightening lug nuts will result in breaking the studs or permanently deforming the mounting stud holes in the wheels.

## WARNING - Lug Nut Inspection

Lug nuts are prone to loosen after initial installation, which can lead to death or serious injury. Check all wheel lug nuts periodically.

## Lug Nut Torque Requirements

It is extremely important to apply and maintain proper wheel mounting torque on the trailer. Be sure to use only the fasteners matched to the cone angle of the wheel. Proper procedure for attachment of the wheels is as follows:

1. Start all wheel lug nuts by hand.
2. Torque all lug nuts in sequence. See Figure 36. **DO NOT** torque the wheel lug nuts all the way down. Tighten each lug nut in 3 separate passes as defined by Table 9.
3. Check to see if the lug nuts are tight after the first 10, 25 and 50 miles of driving and before each tow thereafter.

**TABLE 9. TIRE TORQUE REQUIREMENTS**

| Wheel Size | First Pass FT-LBS | Second Pass FT-LBS | Third Pass FT-LBS |
|------------|-------------------|--------------------|-------------------|
| 12"        | 20-25             | 35-40              | 50-65             |
| 13"        | 20-25             | 35-40              | 50-65             |
| 14"        | 20-25             | 50-60              | 90-120            |
| 15"        | 20-25             | 50-60              | 90-120            |
| 16"        | 20-25             | 50-60              | 90-120            |

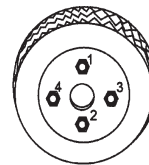

4-LUG NUTS

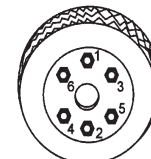

6-LUG NUTS

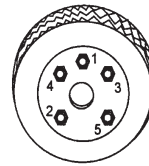

5-LUG NUTS

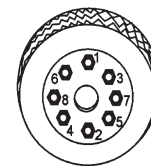

8-LUG NUTS

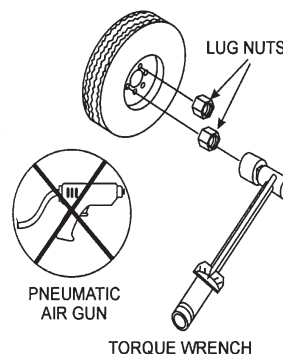

**Figure 36. Wheel Lug Nuts Tightening Sequence**

# TRAILER LIGHTS WIRING DIAGRAM

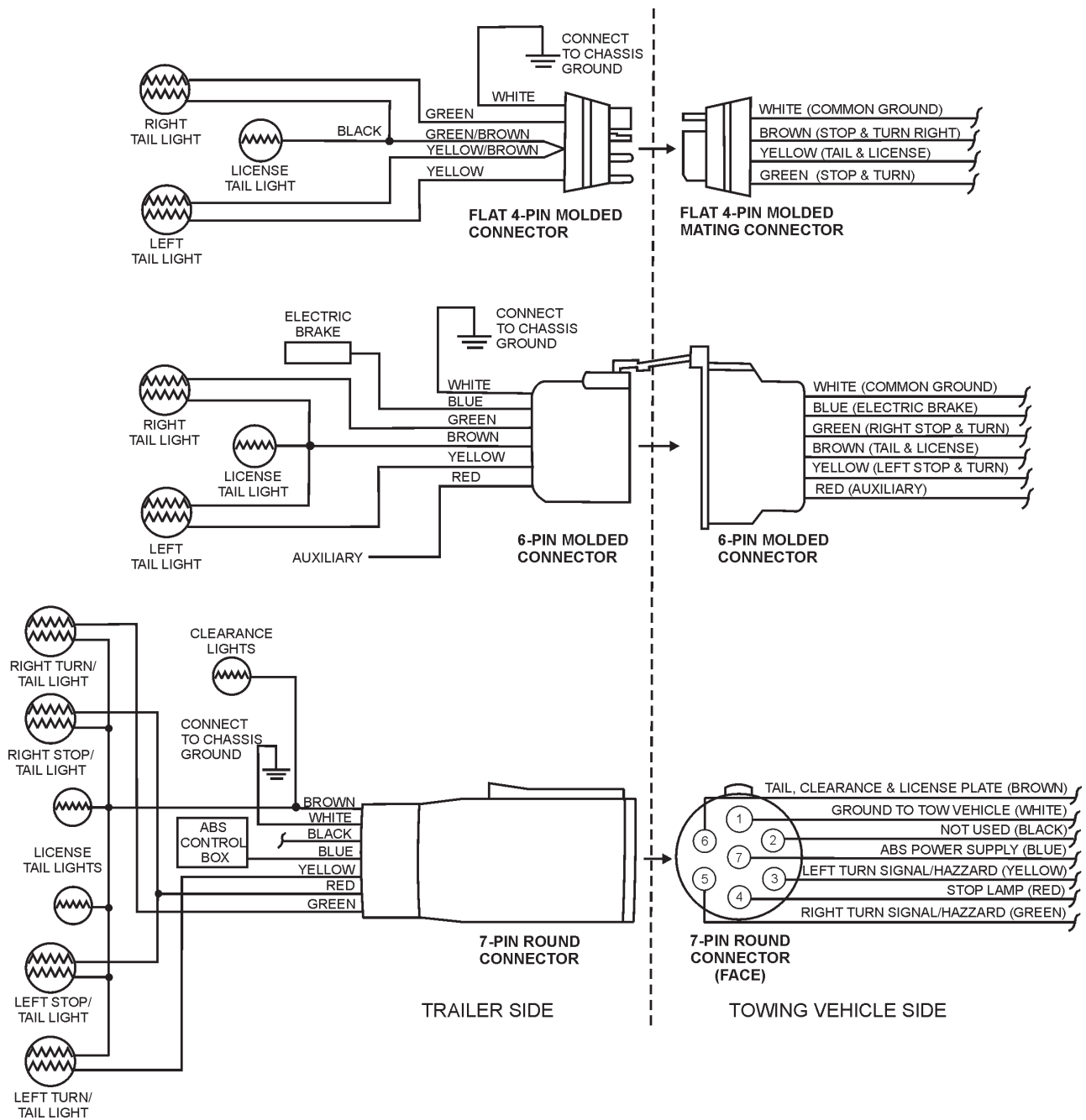

Figure 37 Trailer to Tow Vehicle Wiring Diagrams

## Lights and Signals

Before each tow, check the trailer taillights, stoplights, turn signals and any clearance lights for proper operation. Replace any broken or burned-out lamps as necessary. Check the wire harness for cuts, fraying or other damage. If it needs replacing, contact your dealer.



### WARNING - Trailer Lights

Improper operating taillights, stoplights and turn signals can cause collisions.

Check all lights before each tow.

# NAMEPLATE AND DECALS

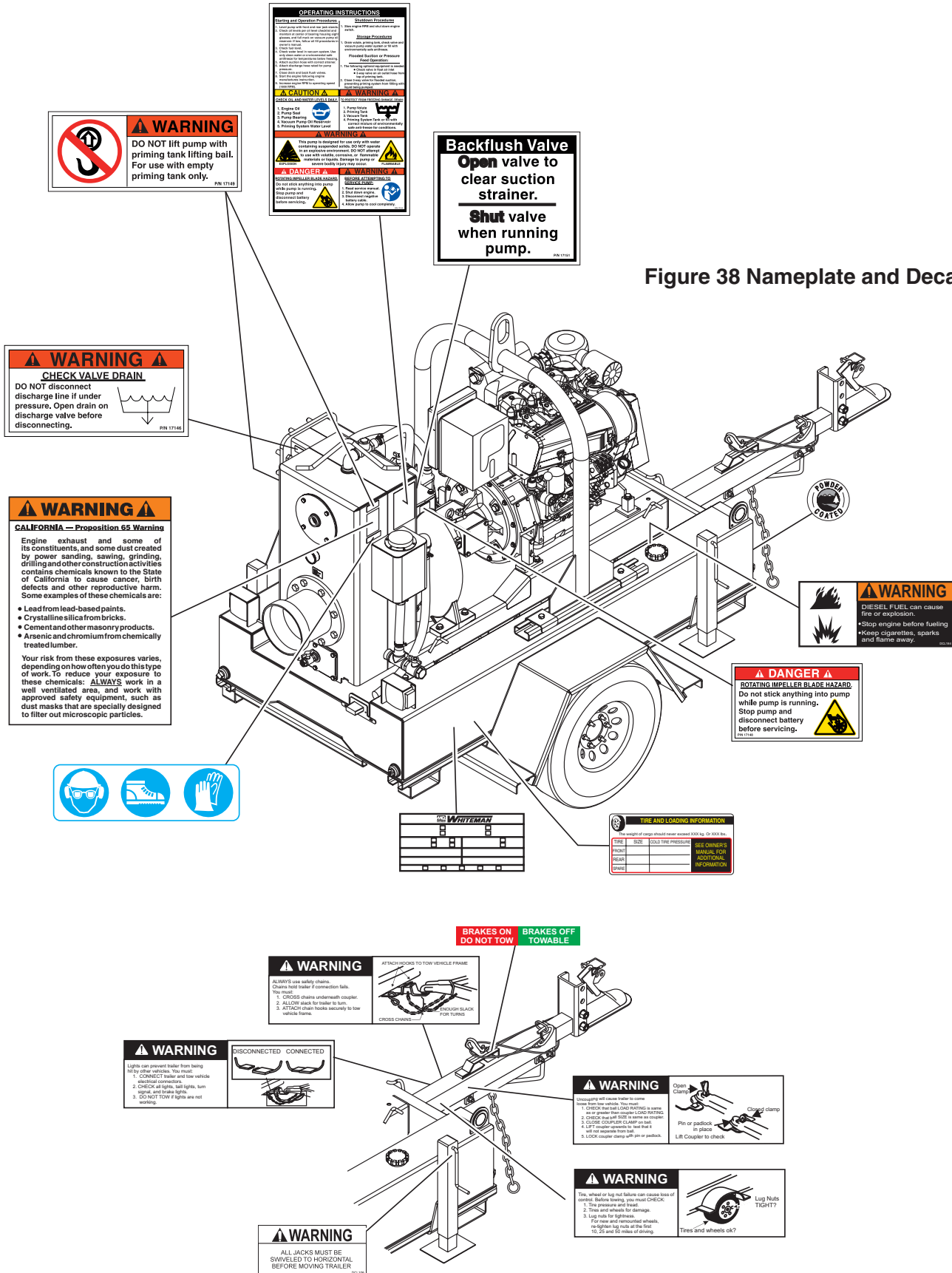

Figure 38 Nameplate and Decals

**WARNING**

DO NOT lift pump with priming tank lifting bail. For use with empty priming tank only.

PN 17142

**OPERATING INSTRUCTIONS**

**Starting and Operation Precautions:**

1. Read and understand all instructions.
2. Do not use pump to lift or move people.
3. Do not use pump to lift or move equipment.
4. Do not use pump to lift or move equipment.
5. Do not use pump to lift or move equipment.
6. Do not use pump to lift or move equipment.
7. Do not use pump to lift or move equipment.
8. Do not use pump to lift or move equipment.
9. Do not use pump to lift or move equipment.
10. Do not use pump to lift or move equipment.

**SAFETY WARNINGS:**

This pump is designed for use only with water. Do not use with other liquids. Do not use with flammable, toxic, or corrosive liquids. Do not use with liquids containing suspended solids. Do not use with liquids containing suspended solids.

**CAUTION:**

1. Engine Oil
2. Fuel Valve
3. Pump Bearing
4. Pressure Relief Valve
5. Priming System Water Level

**WARNING:**

1. Fuel Valve
2. Pressure Relief Valve
3. Priming System Water Level
4. Do not use pump to lift or move equipment.
5. Do not use pump to lift or move equipment.
6. Do not use pump to lift or move equipment.
7. Do not use pump to lift or move equipment.
8. Do not use pump to lift or move equipment.
9. Do not use pump to lift or move equipment.
10. Do not use pump to lift or move equipment.

**Backflush Valve**

Open valve to clear suction strainer.

Shut valve when running pump.

PN 17143

**WARNING**

**CHECK VALVE DRAIN**

DO NOT disconnect discharge line if under pressure. Open drain on discharge valve before disconnecting.

PN 17146

**WARNING**

**CALIFORNIA — Proposition 65 Warning**

Engine exhaust and some of its constituents, and some dust created by power sanding, sawing, grinding, drilling and other construction activities contains chemicals known to the State of California to cause cancer, birth defects and other reproductive harm. Some examples of these chemicals are:

- Lead from lead-based paints.
- Crystalline silica from bricks.
- Cement and other masonry products.
- Arsenic and chromium from chemically treated lumber.

Your risk from these exposures varies, depending on how often you do this type of work. To reduce your exposure to these chemicals: ALWAYS work in a well ventilated area, and work with approved safety equipment, such as dust masks that are specially designed to filter out microscopic particles.



**WARNING**

DIESEL FUEL can cause fire or explosion.

Stop engine before fueling.

Keep cigarettes, sparks and flames away.

**DANGER**

**ROTATING IMPELLER BLADE HAZARD.**

Do not stick anything into pump while pump is running. Stop pump and disconnect battery before servicing.

**TIRE AND LOADING INFORMATION**

Weight of pump should never exceed 1000 lbs. (453 kg).

| TIRE  | SIZE | COLD TIRE PRESSURE | SEE OWNER'S MANUAL FOR ADDITIONAL INFORMATION |
|-------|------|--------------------|---|
| FRONT |      |                    |   |
| REAR  |      |                    |   |
| SPARE |      |                    |   |

**BRAKES ON DO NOT TOW**    **BRAKES OFF TOWABLE**

**WARNING**

ALWAYS use safety chains. Chain ball trailer connection fails. You must:

1. CROSS chains underneath coupler.
2. ALLOW slack for trailer to turn.
3. ATTACH chain hooks securely to tow vehicle frame.



**WARNING**

Lights can prevent trailer from being lit by other vehicles. You must:

1. CONNECT trailer and tow vehicle electrical connectors.
2. CHECK all lights, tail lights, turn signals, and brake lights.
3. DO NOT TOW if lights are not working.

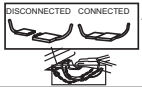

**WARNING**

Unsealing will cause water to come from the vehicle. You must:

1. CHECK that the LIFT CLAMP is open, or is open greater than 90 degrees (LIFT CLAMP).
2. CHECK that the BALL BEARING is seated.
3. CLOSE COUPLER CLAMP on ball.
4. LEFT coupler connects to ball first.
5. LOCK coupler clasp with pin or padlock.

Open Clasp

Pin or padlock in place

Lift Coupler to check

**WARNING**

Tire, wheel or lug nut failure can cause loss of control. Before driving, you must CHECK:

1. The pressure and tread.
2. Tire and wheel for damage.
3. Lug nuts for tightness.

For new and remounted wheels, re-tighten lug nuts at the first 10, 25 and 50 miles of driving.

Lug Nuts TIGHT?

Tires and wheels ok?

**WARNING**

ALL JACKS MUST BE SWIVELED TO HORIZONTAL BEFORE MOVING TRAILER.

PN 17147

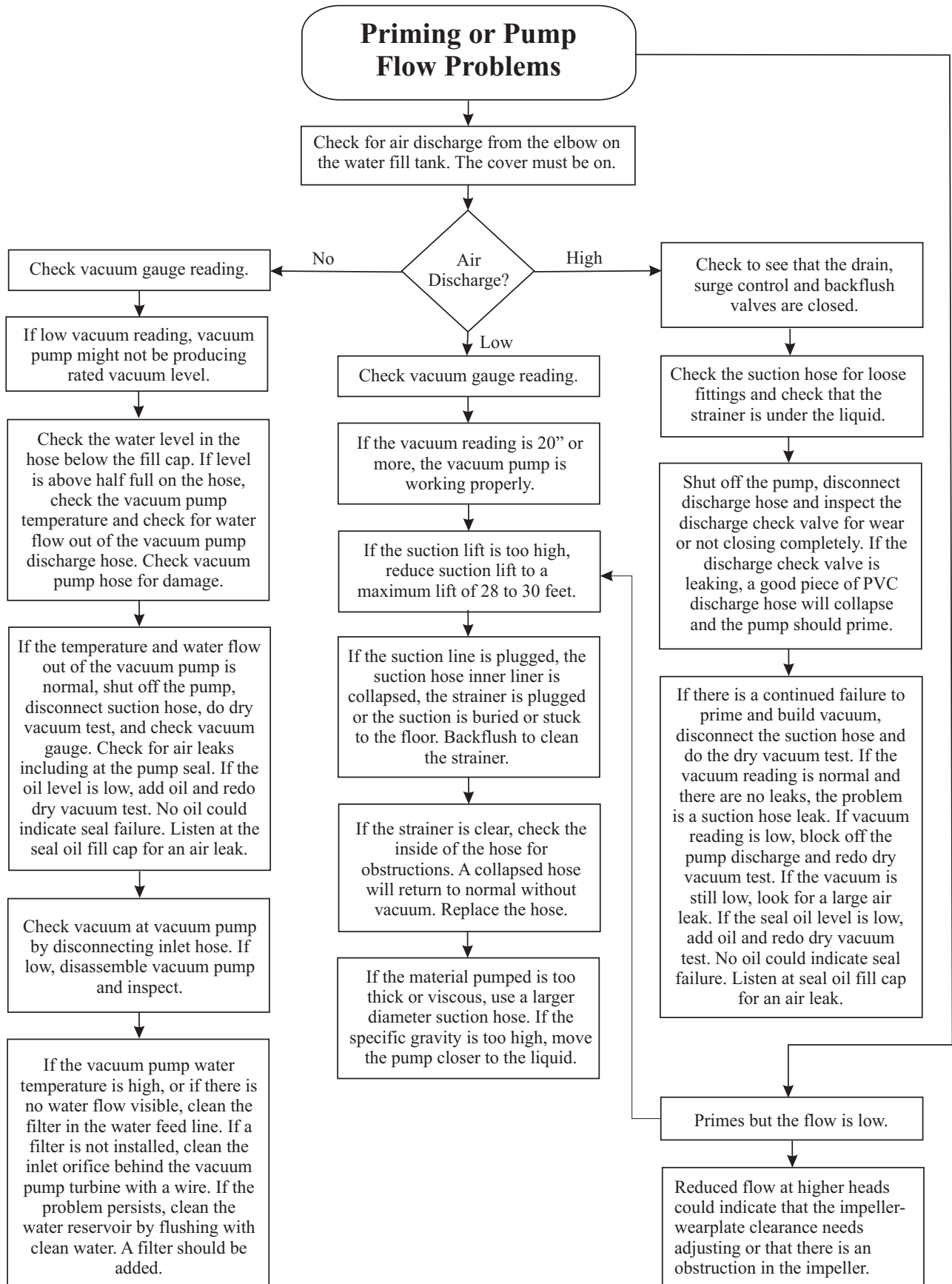

# TROUBLESHOOTING (ENGINE)

**TABLE 10. ENGINE TROUBLESHOOTING**

| SYMPTOM  | POSSIBLE PROBLEM   | SOLUTION   |
|--|--|--|
| Engine will not start or start is delayed, although engine can be turned over. | Speed control lever is in "STOP" position?                               | Set speed control lever to "START" position.   |
|  | STOP solenoid is in the "STOP" position?                                 | Set stop solenoid to the "START" position. Adjust and lubricate if necessary.  |
|  | No fuel reaching injection pump?   | Add fuel. Check entire fuel system.  |
|  | Defective fuel pump?   | Replace fuel pump.   |
|  | Fuel filter clogged?   | Replace fuel filter and clean tank.  |
|  | Faulty fuel supply line?   | Replace or repair fuel line.   |
|  | Compression too low?   | Check piston, cylinder and valves. Adjust or repair per engine repair manual.  |
|  | Fuel injector not working correctly?                                     | Repair or replace injector in accordance with engine repair manual.  |
|  | Oil pressure too low?  | Check engine oil pressure.   |
|  | Low starting temperature limit exceeded                                  | Comply with cold starting instructions and proper oil viscosity.   |
|  | Defective battery?   | Charge or replace battery.   |
| At low temperatures engine will not start.                                     | Fuel separates has inadequate resistance to low temperatures?            | Check whether clear (not turbid) fuel emerges from the fuel line (detach from injection pump). If the fuel is turbid or separated either, warm up the engine or drain the complete fuel supply system. Refuel with winter grade diesel fuel. |
|  | Engine oil too thick?  | Refill engine crankcase with correct type of oil for winter environment.   |
|  | Defective battery?   | Replace battery.   |
| Engine fires but stops soon as starter is switched off.                        | Throttle lever in STOP position?   | Reposition throttle lever to RUN position.   |
|  | Fuel filter blocked?   | Replace fuel filter.   |
|  | Fuel supply blocked?   | Check the entire fuel system.  |
|  | Electrical problem at fuel solenoid?                                     | Repair using #7 wire.  |
| Engine stops by itself during normal operation.                                | Fuel tank empty?   | Add fuel.  |
|  | Fuel filter blocked?   | Replace fuel filter.   |
|  | Defective fuel pump?   | Replace fuel pump.   |
|  | Mechanical oil pressure shutdown sensor stops the engine due to low oil? | Add oil. Replace low oil shutdown sensor if necessary.   |

**TABLE 10. ENGINE TROUBLESHOOTING (CONTINUED)**

| SYMPTOM   | POSSIBLE PROBLEM  | SOLUTION  |
|---|---|---|
| Low engine power, output and speed.   | Fuel tank empty?  | Replace fuel filter.  |
|   | Fuel filter clogged?  | Replace fuel filter.  |
|   | Fuel tank venting is inadequate?                            | Ensure that tank is adequately vented.  |
|   | Leaks at pipe unions?                                       | Check threaded pipe unions tape and tighten unions as required.                           |
|   | Speed control lever does not remain in selected position?   | See engine manual for corrective action.  |
|   | Engine oil level too full?                                  | Correct engine oil level?   |
| Low engine power output and low speed, black exhaust smoke.                                       | Air filter blocked?   | Clean or replace air filter.  |
|   | Incorrect valve clearances?                                 | Adjust valves per engine specification.   |
|   | Malfunction at injector?                                    | See engine manual.  |
| Air-cooled diesel engine runs very "HOT". Cylinder head overheat, telltale lamp comes on (option) | Too much oil in engine crankcase?                           | Drain off engine oil down to uppermark on dipstick.                                       |
|   | Entire cooling air system contaminated blocked?             | Clean cooling air system, remove shrouds and cooling fin areas.                           |
|   | Inadequate sealing at air guide plates or capsule elements? | Check that air guide plates and enclosure elements are all present and make a tight seal. |

# TROUBLESHOOTING (TRAILER BRAKES)

## Table 11. Surge Brake Troubleshooting

| Symptom                                | Possible Cause   | Solution                                    |
|--|--|---|
| No Brakes                              | Brake line broken or kinked?                               | Repair or replace.                          |
| Weak Brakes or Brakes Pull to One Side | Brake lining glazed?                                       | Reburnish or replace.                       |
|  | Trailer overloaded?  | Correct weight.                             |
|  | Brake drums scored or grooved?                             | Machine or replace.                         |
|  | Tire pressure correct?                                     | Inflate all tires equally.                  |
|  | Tires unmatched on the same axle?                          | Match tires.                                |
| Locking Brakes                         | Brake components loose, bent or broken?                    | Replace components.                         |
|  | Brake drums out-of-round?                                  | Replace.                                    |
| Noisy Brakes                           | System lubricated?   | Lubricate.                                  |
|  | Brake components correct?                                  | Replace and correct.                        |
| Dragging Brakes                        | Brake lining thickness correct or in right wrong position? | Install new shoes and linings.              |
|  | Enough brake fluid or correct fluid?                       | Replace rubber parts fill with Dot 4 fluid. |

## Table 12. Electric Brake Troubleshooting

| Symptom                                | Possible Cause                          | Solution                              |
|--|---|---------------------------------------|
| No Brakes or Intermittent Brakes       | Any open circuits or broken wires?      | Find and correct.                     |
|  | Any short circuits?                     | Find and correct.                     |
|  | Faulty controller?                      | Test and correct.                     |
|  | Any loose connections?                  | Find and repair.                      |
|  | Ground wire secure?                     | Find and secure.                      |
| Weak Brakes or Brakes Pull to One Side | Grease or oil on magnets or linings?    | Clean or replace.                     |
|  | Connections corroded?                   | Clean and correct cause of corrosion. |
|  | Brake drums scored or grooved?          | Machine or replace.                   |
|  | Brakes synchronized?                    | Correct.                              |
| Locking Brakes                         | Brake components loose, bent or broken? | Replace components.                   |
|  | Brake drums out-of-round?               | Replace.                              |
| Noisy Brakes                           | System lubricated?                      | Lubricate.                            |
|  | Brake components correct?               | Replace and correct.                  |
| Dragging Brakes                        | Bearings of the wheel adjusted?         | Adjust.                               |





# OPERATION MANUAL

## HERE'S HOW TO GET HELP

PLEASE HAVE THE MODEL AND SERIAL  
NUMBER *ON-HAND* WHEN CALLING

### UNITED STATES

#### ***Multiquip Corporate Office***

18910 Wilmington Ave. Tel. (800) 421-1244  
Carson, CA 90746 Fax (800) 537-3927  
Contact: mq@multiquip.com

#### ***Mayco Parts***

800-306-2926 Fax: 800-672-7877  
310-537-3700 Fax: 310-637-3284

#### ***Service Department***

800-421-1244 Fax: 310-537-4259  
310-537-3700

#### ***MQ Parts Department***

800-427-1244 Fax: 800-672-7877  
310-537-3700 Fax: 310-637-3284

#### ***Warranty Department***

800-421-1244, Ext. 279 Fax: 310-537-1173  
310-537-3700, Ext. 279

#### ***Technical Assistance***

800-478-1244 Fax: 310-631-5032

### MEXICO

#### ***MQ Cipsa***

Carr. Fed. Mexico-Puebla KM 126.5 Tel: (52) 222-225-9900  
Momoxpan, Cholula, Puebla 72760 Mexico Fax: (52) 222-285-0420  
Contact: pmastretta@cipsa.com.mx

### CANADA

#### ***Multiquip***

4110 Industriel Boul. Tel: (450) 625-2244  
Laval, Quebec, Canada H7L 6V3 Fax: (450) 625-8664  
Contact: jmartin@multiquip.com

### UNITED KINGDOM

#### ***Multiquip (UK) Limited Head Office***

Hanover Mill, Fitzroy Street, Tel: 0161 339 2223  
Ashton-under-Lyne, Fax: 0161 339 3226  
Lancashire OL7 0TL  
Contact: sales@multiquip.co.uk

### BRAZIL

#### ***Multiquip***

Av. Evandro Lins e Silva, 840 - grupo 505 Tel: 011-55-21-3433-9055  
Barra de Tijuca - Rio de Janeiro Fax: 011-55-21-3433-9055  
Contact: cnavarro@multiquip.com.br, srentes@multiquip.com.br

© COPYRIGHT 2008, MULTIQUIP INC.

Multiquip Inc. and the MQ logo are registered trademarks of Multiquip Inc. and may not be used, reproduced, or altered without written permission. All other trademarks are the property of their respective owners and used with permission.

This manual MUST accompany the equipment at all times. This manual is considered a permanent part of the equipment and should remain with the unit if resold.

The information and specifications included in this publication were in effect at the time of approval for printing. Illustrations, descriptions, references and technical data contained in this manual are for guidance only and may not be considered as binding. Multiquip Inc. reserves the right to discontinue or change specifications, design or the information published in this publication at any time without notice and without incurring any obligations.

Your Local Dealer is:



## Free Manuals Download Website

<http://myh66.com>

<http://usermanuals.us>

<http://www.somanuals.com>

<http://www.4manuals.cc>

<http://www.manual-lib.com>

<http://www.404manual.com>

<http://www.luxmanual.com>

<http://aubethermostatmanual.com>

Golf course search by state

<http://golfingnear.com>

Email search by domain

<http://emailbydomain.com>

Auto manuals search

<http://auto.somanuals.com>

TV manuals search

<http://tv.somanuals.com>