

OPERATION AND PARTS MANUAL



WHISPERWATT™ SERIES MODEL DCA300SSC MODEL DCA300SSCU 60HZ GENERATOR (CUMMINS QSL9-G3 DIESEL ENGINE)

**PARTS LIST NO. C2870300204 — DCA300SSC
PARTS LIST NO. C2870300104A — DCA300SSCU**

Revision #1 (08/10/11)

To find the latest revision of this
publication, visit our website at:
www.multiquip.com



THIS MANUAL MUST ACCOMPANY THE EQUIPMENT AT ALL TIMES.



CALIFORNIA — Proposition 65 Warning

Diesel engine exhaust and some of its constituents are known to the State of California to cause cancer, birth defects and other reproductive harm.

REPORTING SAFETY DEFECTS

If you believe that your vehicle has a defect that could cause a crash or could cause injury or death, you should immediately inform the National Highway Traffic Safety Administration (NHTSA) in addition to notifying Multiquip at 1-800-421-1244.

If NHTSA receives similar complaints, it may open an investigation, and if it finds that a safety defect exists in a group of vehicles, it may order a recall and remedy campaign. However, NHTSA cannot become involved in individual problems between you, your dealer, or Multiquip.

To contact NHTSA, you may either call the Vehicle Safety Hotline toll-free at 1-888-327-4236 (TTY: 1-800-424-9153), go to <http://www.nhtsa.dot.gov>; or write to:

Administrator
NHTSA
1200 New Jersey Avenue S.E.
Washington, DC 20590

You can also obtain information about motor vehicle safety from <http://www.safercar.gov>.

TABLE OF CONTENTS

DCA300SSC/DCA300SSCU 60 Hz Generators

Proposition 65 warning	2
Reporting Safety Defects.....	3
Table of Contents.....	4
Parts Ordering Procedures.....	5
Safety Information	6-11
Specifications	12
Dimensions.....	13
Installation	14-15
General Information.....	16
Major Components	17
Generator Control Panel.....	18-19
Engine Operating Panel.....	20-21
Output Terminal Panel Familiarization	22-24
Load Application	25
Generator Outputs.....	26
Generator Outputs/Gauge Reading.....	27
Output Terminal Panel Connections	28-29
Inspection/Setup.....	30-33
Generator Start-Up Procedure (Manual).....	34-35
Generator Start-Up Procedure (Auto Mode).....	36
Generator Shut-Down Procedures	37
Maintenance	38-41
Trailer Maintenance	42-45
Trailer Wiring Diagram	46
Generator Wiring Diagram.....	47
Engine Wiring Diagram.....	48
Controller Wiring Diagram	49
Troubleshooting (Generator).....	50
Troubleshooting (Engine Controller)	51
Troubleshooting (Diagnostic lamp)	52
Explanation of Code in Remarks Column.....	54
Suggested Spare Parts	55

Component Drawings

Generator Assembly	56-59
Control Box Assembly.....	60-63
Engine and Radiator Assembly.....	64-67
Engine Operating Panel Assembly.....	68-69
Output Terminal Assembly	70-74
Battery Assembly (DCA300SSC)	75-76
Battery Assembly (DCA300SSCU).....	77-78
Muffler Assembly.....	79-80
Fuel Tank Assembly (DCA300SSC).	81-82
Fuel Tank Assembly (DCA300SSCU).....	83-84
Enclosure Assembly	85-91
Rubber Seals Assembly	92-93
Nameplt.and Decals Assy. (DCA300SSC).....	94-97
Nameplt. and Decals Assy. (DCA300SSCU). .	98-101

Terms and Conditions of Sale — Parts	102
--	-----

PARTS ORDERING PROCEDURES

Ordering parts has never been easier! Choose from three easy options:

Effective:
January 1st, 2006

www.multiquip.com



Order via Internet (Dealers Only):

Order parts on-line using Multiquip's SmartEquip website!

- View Parts Diagrams
- Order Parts
- Print Specification Information



If you have an MQ Account, to obtain a Username and Password, E-mail us at: parts@multiquip.com.

To obtain an MQ Account, contact your District Sales Manager for more information.

Goto www.multiquip.com and click on **Order Parts** to log in and save!

Use the **internet** and qualify for a **5% Discount** on *Standard orders* for all orders which include complete part numbers.*

Note: Discounts Are Subject To Change



Order via Fax (Dealers Only):

All customers are welcome to order parts via Fax.

Domestic (US) Customers dial:
1-800-6-PARTS-7 (800-672-7877)

Fax your order in and qualify for a **2% Discount** on *Standard orders* for all orders which include complete part numbers.*

Note: Discounts Are Subject To Change



Order via Phone: Domestic (US) Dealers Call:
1-800-427-1244

Non-Dealer Customers:

Contact your local Multiquip Dealer for parts or call 800-427-1244 for help in locating a dealer near you.



International Customers should contact their local Multiquip Representatives for Parts Ordering information.

When ordering parts, please supply:

- | | |
|---|--|
| <input type="checkbox"/> Dealer Account Number | <input type="checkbox"/> Specify Preferred Method of Shipment: |
| <input type="checkbox"/> Dealer Name and Address | <input checked="" type="checkbox"/> UPS/Fed Ex <input checked="" type="checkbox"/> DHL |
| <input type="checkbox"/> Shipping Address (if different than billing address) | <input type="checkbox"/> Priority One <input checked="" type="checkbox"/> Truck |
| <input type="checkbox"/> Return Fax Number | <input type="checkbox"/> Ground |
| <input type="checkbox"/> Applicable Model Number | <input type="checkbox"/> Next Day |
| <input type="checkbox"/> Quantity, Part Number and Description of Each Part | <input type="checkbox"/> Second/Third Day |

NOTICE

All orders are treated as *Standard Orders* and will ship the same day if received prior to 3PM PST.

WE ACCEPT ALL MAJOR CREDIT CARDS!



SAFETY INFORMATION

Do not operate or service the equipment before reading the entire manual. Safety precautions should be followed at all times when operating this equipment. Failure to read and understand the safety messages and operating instructions could result in injury to yourself and others.

SAFETY MESSAGES

The four safety messages shown below will inform you about potential hazards that could injure you or others. The safety messages specifically address the level of exposure to the operator and are preceded by one of four words: **DANGER**, **WARNING**, **CAUTION** or **NOTICE**.

SAFETY SYMBOLS

 **DANGER**

Indicates a hazardous situation which, if not avoided, **WILL** result in **DEATH** or **SERIOUS INJURY**.

 **WARNING**

Indicates a hazardous situation which, if not avoided, **COULD** result in **DEATH** or **SERIOUS INJURY**.







 **CAUTION**

Indicates a hazardous situation which, if not avoided, **COULD** result in **MINOR** or **MODERATE INJURY**.

NOTICE

Addresses practices not related to personal injury.

Potential hazards associated with the operation of this equipment will be referenced with hazard symbols which may appear throughout this manual in conjunction with safety messages.

Symbol	Safety Hazard
	Lethal exhaust gas hazards
	Explosive fuel hazards
	Burn hazards
	Overspeed hazards
	Rotating parts hazards
	Pressurized fluid hazards
	Electric shock hazards

SAFETY INFORMATION

GENERAL SAFETY

CAUTION

- **NEVER** operate this equipment without proper protective clothing, shatterproof glasses, respiratory protection, hearing protection, steel-toed boots and other protective devices required by the job or city and state regulations.



- **NEVER** operate this equipment when not feeling well due to fatigue, illness or when under medication.



- **NEVER** operate this equipment under the influence of drugs or alcohol.



- **ALWAYS** check the equipment for loosened threads or bolts before starting.
- **DO NOT** use the equipment for any purpose other than its intended purposes or applications.

NOTICE

- This equipment should only be operated by trained and qualified personnel 18 years of age and older.
- Whenever necessary, replace nameplate, operation and safety decals when they become difficult read.
- Manufacturer does not assume responsibility for any accident due to equipment modifications. Unauthorized equipment modification will void all warranties.

- **NEVER** use accessories or attachments that are not recommended by MQ Power for this equipment. Damage to the equipment and/or injury to user may result.

- **ALWAYS** know the location of the nearest **fire extinguisher**.



- **ALWAYS** know the location of the nearest **first aid kit**.



- **ALWAYS** know the location of the nearest phone or **keep a phone on the job site**. Also, know the phone numbers of the nearest **ambulance, doctor and fire department**. This information will be invaluable in the case of an emergency.



GENERATOR SAFETY

DANGER

- **NEVER** operate the equipment in an explosive atmosphere or near combustible materials. An explosion or fire could result causing severe **bodily harm or even death**.



WARNING

- **NEVER** disconnect any **emergency or safety devices**. These devices are intended for operator safety. Disconnection of these devices can cause severe injury, bodily harm or even death. Disconnection of any of these devices will void all warranties.

CAUTION

- **NEVER** lubricate components or attempt service on a running machine.

NOTICE

- **ALWAYS** ensure generator is on level ground before use.
- **ALWAYS** keep the machine in proper running condition.
- Fix damage to machine and replace any broken parts immediately.
- **ALWAYS** store equipment properly when it is not being used. Equipment should be stored in a clean, dry location out of the reach of children and unauthorized personnel

SAFETY INFORMATION

ENGINE SAFETY

DANGER

- The engine fuel exhaust gases contain poisonous carbon monoxide. This gas is colorless and odorless, and can cause death if inhaled.
- The engine of this equipment requires an adequate free flow of cooling air. **NEVER** operate this equipment in any enclosed or narrow area where free flow of the air is restricted. If the air flow is restricted it will cause injury to people and property and serious damage to the equipment or engine.



WARNING

- **DO NOT** place hands or fingers inside engine compartment when engine is running.
- **NEVER** operate the engine with heat shields or guards removed.
- Keep fingers, hands hair and clothing away from all moving parts to prevent injury.
- **DO NOT** remove the radiator cap while the engine is hot. High pressure boiling water will gush out of the radiator and severely scald any persons in the general area of the generator.
- **DO NOT** remove the coolant drain plug while the engine is hot. Hot coolant will gush out of the coolant tank and severely scald any persons in the general area of the generator.
- **DO NOT** remove the engine oil drain plug while the engine is hot. Hot oil will gush out of the oil tank and severely scald any persons in the general area of the generator.



CAUTION

- **NEVER** touch the hot exhaust manifold, muffler or cylinder. Allow these parts to cool before servicing equipment.



NOTICE

- **NEVER** run engine without an air filter or with a dirty air filter. Severe engine damage may occur. Service air filter frequently to prevent engine malfunction.
- **NEVER** tamper with the factory settings of the engine or engine governor. Damage to the engine or equipment can result if operating in speed ranges above the maximum allowable.
- Wet stacking is a common problem with diesel engines which are operated for extended periods with light or no load applied. When a diesel engine operates without sufficient load (less than 40% of the rated output), it will not operate at its optimum temperature. This will allow unburned fuel to accumulate in the exhaust system, which can foul the fuel injectors, engine valves and exhaust system, including turbochargers, and reduce the operating performance.



In order for a diesel engine to operate at peak efficiency, it must be able to provide fuel and air in the proper ratio and at a high enough engine temperature for the engine to completely burn all of the fuel.

Wet stacking does not usually cause any permanent damage and can be alleviated if additional load is applied to relieve the condition. It can reduce the system performance and increase maintenance. Applying an increasing load over a period of time until the excess fuel is burned off and the system capacity is reached usually can repair the condition. This can take several hours to burn off the accumulated unburned fuel.

- State Health Safety Codes and Public Resources Codes specify that in certain locations, spark arresters must be used on internal combustion engines that use hydrocarbon fuels. A spark arrester is a device designed to prevent accidental discharge of sparks or flames from the engine exhaust. Spark arresters are qualified and rated by the United States Forest Service for this purpose. In order to comply with local laws regarding spark arresters, consult the engine distributor or the local Health and Safety Administrator.

SAFETY INFORMATION

FUEL SAFETY

DANGER

- **DO NOT** start the engine near spilled fuel or combustible fluids. Diesel fuel is extremely flammable and its vapors can cause an explosion if ignited.
- **ALWAYS** refuel in a well-ventilated area, away from sparks and open flames.
- **ALWAYS** use extreme caution when working with **flammable** liquids.
- **DO NOT** fill the fuel tank while the engine is running or hot.
- **DO NOT** overfill tank, since spilled fuel could ignite if it comes into contact with hot engine parts or sparks from the ignition system.
- Store fuel in appropriate containers, in well-ventilated areas and away from sparks and flames.
- **NEVER** use fuel as a cleaning agent.
- **DO NOT** smoke around or near the equipment. Fire or explosion could result from fuel vapors or if fuel is spilled on a hot engine.



TOWING SAFETY

CAUTION

- Check with your local county or state safety towing regulations, in addition to meeting **Department of Transportation (DOT) Safety Towing Regulations**, before towing your generator.
- Refer to MQ Power trailer manual for additional safety information.
- In order to reduce the possibility of an accident while transporting the generator on public roads, **ALWAYS** make sure the trailer that supports the generator and the towing vehicle are mechanically sound and in good operating condition.
- **ALWAYS** shutdown engine before transporting



- Make sure the hitch and coupling of the towing vehicle are rated equal to, or greater than the trailer “gross vehicle weight rating.”
- **ALWAYS** inspect the hitch and coupling for wear. **NEVER** tow a trailer with defective hitches, couplings, chains, etc.
- Check the tire air pressure on both towing vehicle and trailer. **Trailer tires should be inflated to 50 psi cold.** Also check the tire tread wear on both vehicles.
- **ALWAYS** make sure the trailer is equipped with a **safety chain**.
- **ALWAYS** properly attach trailer’s safety chains to towing vehicle.
- **ALWAYS** make sure the vehicle and trailer directional, backup, brake and trailer lights are connected and working properly.
- DOT Requirements include the following:
 - Connect and test electric brake operation.
 - Secure portable power cables in cable tray with tie wraps.
- The maximum speed for highway towing is **55 MPH** unless posted otherwise. Recommended off-road towing is not to exceed **15 MPH** or less depending on type of terrain.
- Avoid sudden stops and starts. This can cause skidding, or jack-knifing. Smooth, gradual starts and stops will improve towing.
- Avoid sharp turns to prevent rolling.
- Trailer should be adjusted to a level position at all times when towing.
- Raise and lock trailer wheel stand in up position when towing.
- Place **chock blocks** underneath wheel to prevent **rolling** while parked.
- Place **support blocks** underneath the trailer’s bumper to prevent **tipping** while parked.
- Use the trailer’s swivel jack to adjust the trailer height to a level position while parked.

SAFETY INFORMATION

ELECTRICAL SAFETY

DANGER

- **DO NOT** touch output terminals during operation. Contact with output terminals during operation can cause **electrocution, electrical shock or burn.**



- The electrical voltage required to operate the generator can cause severe injury or even death through physical contact with live circuits. Turn generator and all circuit breakers **OFF** before performing maintenance on the generator or making contact with output terminals.

- **NEVER** insert any objects into the output receptacles during operation. This is extremely dangerous. The possibility exists of **electrical shock, electrocution or death.**



- Backfeed to a utility system can cause **electrocution** and/or property damage. **NEVER** connect the generator to a building's electrical system without a transfer switch or other approved device. All installations should be performed by a **licensed electrician** in accordance with all applicable laws and electrical codes. Failure to do so could result in electrical shock or burn, causing **serious injury or even death.**



Power Cord/Cable Safety

DANGER

- **NEVER** let power cords or cables **lay in water.**
- **NEVER stand in water** while AC power from the generator is being transferred to a load.
- **NEVER** use **damaged** or **worn** cables or cords when connecting equipment to generator. Inspect for cuts in the insulation.
- **NEVER** grab or touch a live power cord or cable with wet hands. The possibility exists of **electrical shock, electrocution or death.**

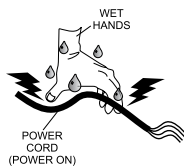

- Make sure power cables are securely connected to the generator's output receptacles. Incorrect connections may cause electrical shock and damage to the generator.

NOTICE

- **ALWAYS** make certain that proper power or extension cord has been selected for the job. See Cable Selection Chart in this manual.

Grounding Safety

DANGER

- **ALWAYS** make sure that electrical circuits are properly grounded to a suitable earth ground (ground rod) per the National Electrical Code (NEC) and local codes before operating generator. **Severe injury or death by electrocution** can result from operating an ungrounded generator.
- **NEVER** use gas piping as an electrical ground.

SAFETY INFORMATION

BATTERY SAFETY

DANGER

- **DO NOT** drop the battery. There is a possibility that the battery will explode.
- **DO NOT** expose the battery to open flames, sparks, cigarettes, etc. The battery contains combustible gases and liquids. If these gases and liquids come into contact with a flame or spark, an explosion could occur.



WARNING

- **ALWAYS** wear safety glasses when handling the battery to avoid eye irritation. The battery contains acids that can cause injury to the eyes and skin.
- Use well-insulated gloves when picking up the battery.
- **ALWAYS** keep the battery charged. If the battery is not charged, combustible gas will build up.
- **ALWAYS** recharge the battery in a well-ventilated environment to avoid the risk of a dangerous concentration of combustible gasses.
- If the battery liquid (dilute sulfuric acid) comes into contact with **clothing or skin**, rinse skin or clothing immediately with plenty of water.
- If the battery liquid (dilute sulfuric acid) comes into contact with **eyes**, rinse eyes immediately with plenty of water and contact the nearest doctor or hospital to seek medical attention.



CAUTION

- **ALWAYS** disconnect the **NEGATIVE battery terminal** before performing service on the generator.
- **ALWAYS** keep battery cables in good working condition. Repair or replace all worn cables.

ENVIRONMENTAL SAFETY

NOTICE

- Dispose of hazardous waste properly. Examples of potentially hazardous waste are used motor oil, fuel and fuel filters.
- **DO NOT** use food or plastic containers to dispose of hazardous waste.
- **DO NOT** pour waste, oil or fuel directly onto the ground, down a drain or into any water source.



SPECIFICATIONS

Table 1. Generator Specifications

Model	DCA300SSC/DCA300SSCU
Type	Revolving field, self ventilated, open protected type synchronous generator
Armature Connection	Star with Neutral
Phase	3
Standby Output	264 KW (330 kVA)
Prime Output	240 KW (300 kVA)
3Ø Voltage (L-L/L-N) Voltage Change-Over Bd. at 3Ø 240/139	208Y/120, 220Y/127, 240Y/139
3Ø Voltage (L-L/L-N) Voltage Change-Over Bd. at 3Ø 480/277	416Y/240, 440Y/254, 480Y/277
1Ø Voltage (L-L/L-N) Voltage Change-Over Bd. at 1Ø 240/120	240/120
Power Factor	0.8
Frequency	60 Hz
Speed	1800 rpm
Aux. AC Power	Single Phase, 60 Hz
Aux. Voltage/Output	4.8 Kw (2.4 kW x 2)
Dry Weight	8,644 lbs. (3,920 kg)
Wet Weight	9,769 lbs. (4,430 kg)

Table 2. Engine Specifications

Model	Cummins QSL9-G3 Tier 3	
Type	4 cycle, water-cooled, direct injection, turbo-charged with air to air after-cooler	
No. of Cylinders	6 cylinders	
Bore x Stroke	4.49 in. x 5.69 in. (114 mm x 145 mm)	
Displacement	543 cu. in. (8900 cc)	
Rated Output	363 HP at 1800 rpm	
Starting	Electric	
Coolant Capacity	11.3 gal. (43.0 liters)	
Lube Oil Capacity	7.0 gal. (26.5 liters)	
Fuel Type	#2 Diesel Fuel	
Fuel Tank Capacity	129 gal. (490 liters)	
Fuel Consumption	19.0 gal. (72.0 L)/hr at full load	15.5 gal. (58.6 L)/hr at 3/4 load
	11.1 gal. (41.9 L)/hr at 1/2 load	5.9 gal. (22.4 L)/hr at 1/4 load
Battery	150 Ah x 2 (24V System)	

DIMENSIONS

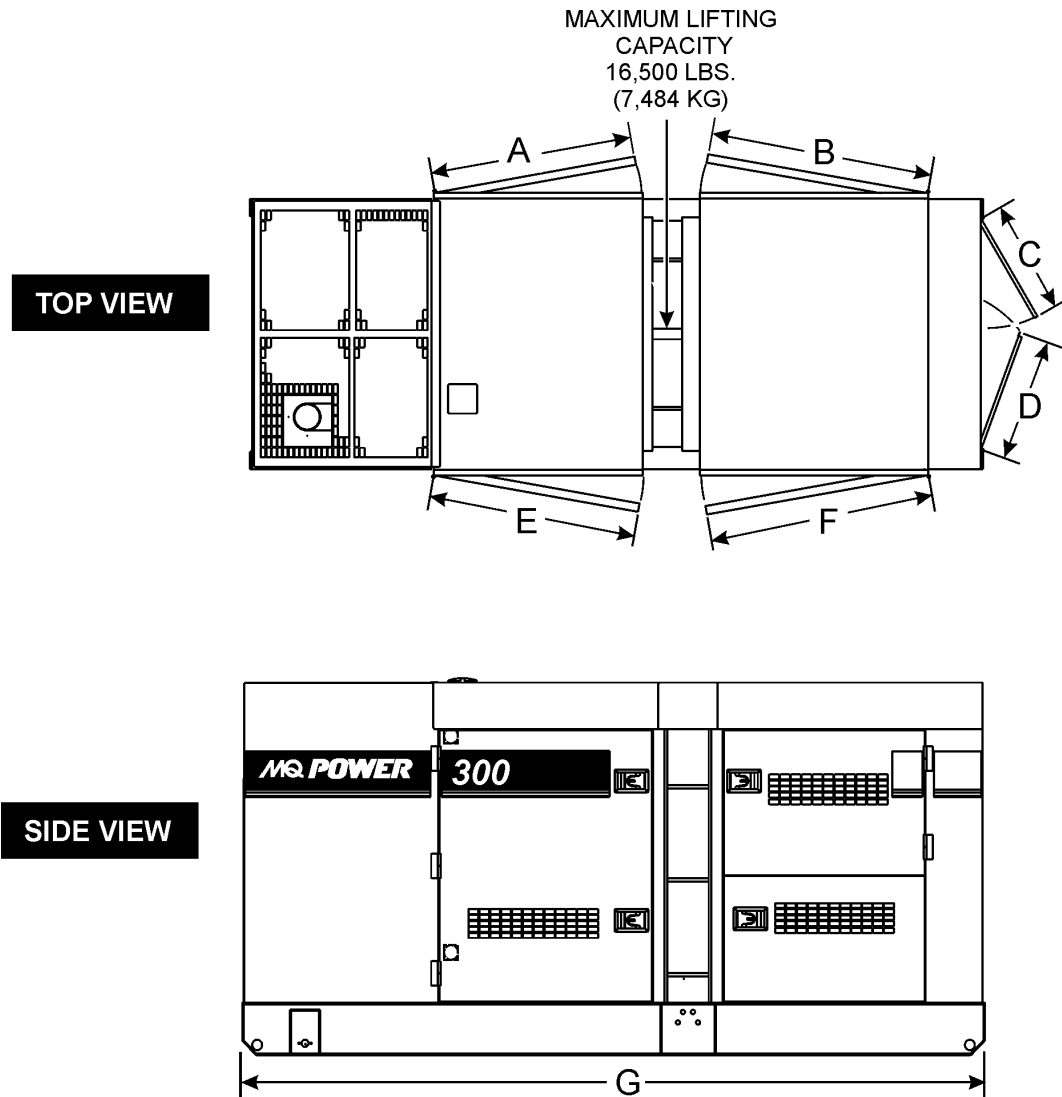

Figure 1. Dimensions

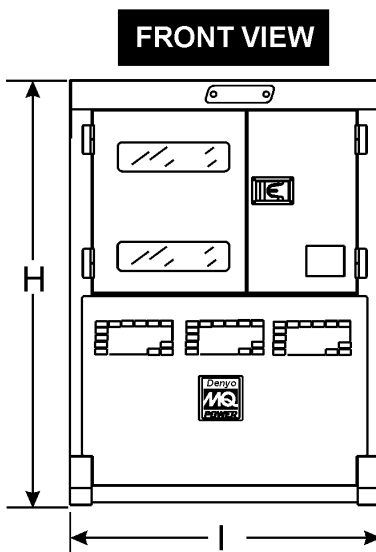

Table 3. Dimensions			
Reference Letter	Dimension in. (mm)	Reference Letter	Dimension in. (mm)
A	39.76 in. (1,010 mm)	F	43.90 in. (1,115 mm)
B	43.90 in. (1,115 mm)	G	149.61 in. (3,800 mm)
C	23.03 in. (585 mm.)	H	70.87 in. (1,800 mm)
D	25.20 in. (640 mm)	I	55.12 in. (1,400 mm)
E	39.76 in. (1,010 mm)		

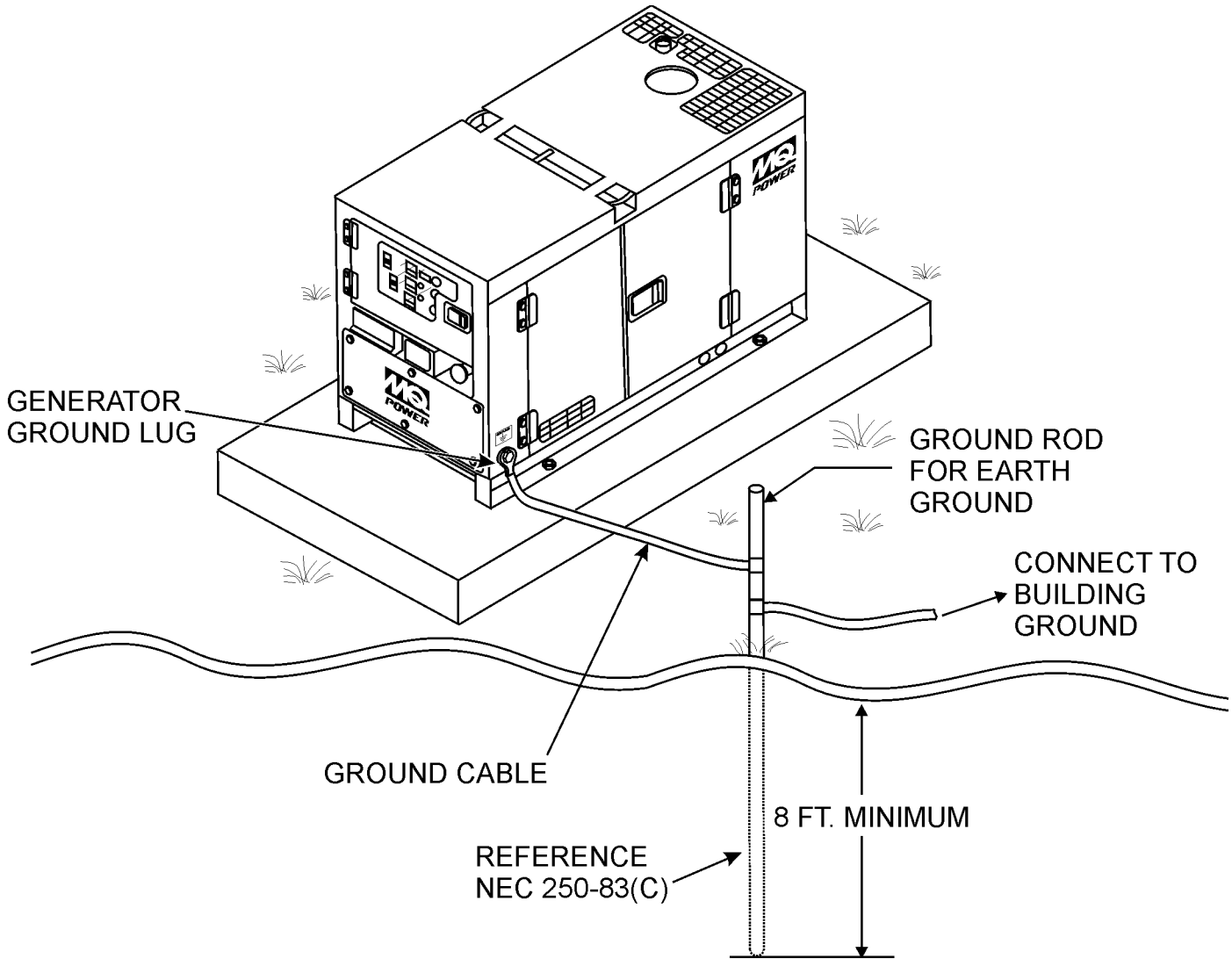

Figure 2. Typical Generator Grounding Application

OUTDOOR INSTALLATION

Install the generator in a area that is free of debris, bystanders, and overhead obstructions. Make sure the generator is on secure level ground so that it cannot slide or shift around. Also install the generator in a manner so that the exhaust will not be discharged in the direction of nearby homes.

The installation site must be relatively free from moisture and dust. All electrical equipment should be protected from excessive moisture. Failure to do will result in deterioration of the insulation and will result in short circuits and grounding.

Foreign materials such as dust, sand, lint and abrasive materials have a tendency to cause excessive wear to engine and alternator parts.

CAUTION

Pay close attention to ventilation when operating the generator inside tunnels and caves. The engine exhaust contains noxious elements. Engine exhaust must be routed to a ventilated area.

INDOOR INSTALLATION

Exhaust gases from diesel engines are extremely poisonous. Whenever an engine is installed indoors the exhaust fumes must be vented to the outside. The engine should be installed at least two feet from any outside wall. Using an exhaust pipe which is too long or too small can cause excessive back pressure which will cause the engine to heat excessively and possibly burn the valves.

MOUNTING

The generator must be mounted on a solid foundation (such as concrete) and set firmly on the foundation to isolate vibration of the generator when it is running. The generator must set at least 6 inches above the floor or grade level (in accordance to NFPA 110, Chapter 5-4.1). **DO NOT** remove the metal skids on the bottom of the generator. They are to resist damage to the bottom of the generator and to maintain alignment.

GENERATOR GROUNDING

To guard against electrical shock and possible damage to the equipment, it is important to provide a good **EARTH** ground.

Article 250 (Grounding) of the National Electrical Code (NEC) provides guide lines for proper grounding and specifies that the cable ground shall be connected to the grounding system of the building as close to the point of cable entry as practical.

NEC articles 250-64(b) and 250-66 set the following grounding requirements:

1. Use one of the following wire types to connect the generator to earth ground.
 - a. Copper - 8 AWG (5.3 mm²)
 - b. Aluminum - 6 AWG (8.4 mm²)
2. When grounding the generator (Figure 2) connect the ground cable between the lock washer and the nut on the generator and tighten the nut fully. Connect the other end of the ground cable to earth ground.
3. NEC article 250-52(c) specifies that the earth ground rod should be buried a minimum of 8 ft. into the ground.

NOTICE

When connecting the generator to any buildings electrical system **ALWAYS** consult with a licensed electrician.

NOTICE

This generator has a permanent bonding conductor between the generator stator windings and the frame.

GENERAL INFORMATION

GENERATOR

The MQ Power DCA300SSC and DCA300SSCU generators (Figure 3) are designed as a high quality portable (requires a trailer for transport) power source for telecom sites, lighting facilities, power tools, submersible pumps and other industrial and construction machinery.

ENGINE OPERATING PANEL

The “Engine Operating Panel” is provided with the following:

- Tachometer
- Emergency Stop Switch
- Water Temperature Gauge
- Oil Pressure Gauge
- Charging Ammeter Gauge
- Fuel Level Gauge
- Pre-Heat Lamp
- Engine Speed Switch
- Battery Switch
- Engine Alarm Lamps (5)

GENERATOR CONTROL PANEL

The “Generator Control Panel” is provided with the following:

- Frequency Meter (Hz)
- AC Ammeter (Amps)
- AC Voltmeter (Volts)
- Ammeter Change-Over Switch
- Voltmeter Change-Over Switch
- Voltage Regulator
- Panel Light/Panel Light Switch
- 3-Pole, 800 amp Main Circuit Breaker
- “Control Box” (located behind the Gen. Control Panel)
 - Automatic Voltage Regulator
 - Current Transformer
 - Over-Current Relay
 - Starter Relay
 - Engine Controller (Computer Controlled)

OUTPUT TERMINAL PANEL

The “Output Terminal Panel” is provided with the following:

- Three 120/240V output receptacles (CS-6369), 50A
- Three auxiliary circuit breakers, 50A
- Two 120V output receptacles (GFCI), 20A
- Two GFCI circuit breakers, 20A
- Eight output terminal lugs (3Ø power)
- Battery Charger (Optional)
- Water Heater (Optional)

OPEN DELTA EXCITATION SYSTEM

Each generator is equipped with the state of the art “Open-Delta” excitation system. The open delta system consist of an electrically independent winding wound among stationary windings of the AC output section.

There are four connections of the open delta A, B, C and D. During steady state loads, the power from the voltage regulator is supplied from the parallel connections of A to B, A to D, and C to D. These three phases of the voltage input to the voltage regulator are then rectified and are the excitation current for the exciter section.

When a heavy load, such as a motor starting or a short circuit occurs, the automatic voltage regulator (AVR) switches the configuration of the open delta to the series connection of B to C. This has the effect of adding the voltages of each phase to provide higher excitation to the exciter section and thus better voltage response during the application of heavy loads.

The connections of the AVR to the AC output windings are for sensing only. No power is required from these windings. The open-delta design provides virtually unlimited excitation current, offering maximum motor starting capabilities. The excitation does not have a “fixed ceiling” and responds according the demands of the required load.

ENGINE

Both generators are powered by a 6 cylinder, 4-cycle water cooled, direct injection, turbocharged, charge air cooled Cummins QSL9-G3 diesel engine. This engine is designed to meet every performance requirement for the generator. Reference Table 2 for engine specifications.

In keeping with MQ Power’s policy of constantly improving its products, the specifications quoted herein are subject to change without prior notice.

ELECTRIC GOVERNOR SYSTEM

The electric governor system controls the RPMs of the engine. When the engine demand increases or decreases, the governor system regulates the frequency variation to $\pm 0.25\%$.

EXTENSION CABLES

When electric power is to be provided to various tools or loads at some distance from the generator, extension cords are normally used. Cables should be sized to allow for distance in length and amperage so that the voltage drop between the generator and point of use (load) is held to a minimum. Use the cable selection chart (Table 6) as a guide for selecting proper extension cable size.

MAJOR COMPONENTS

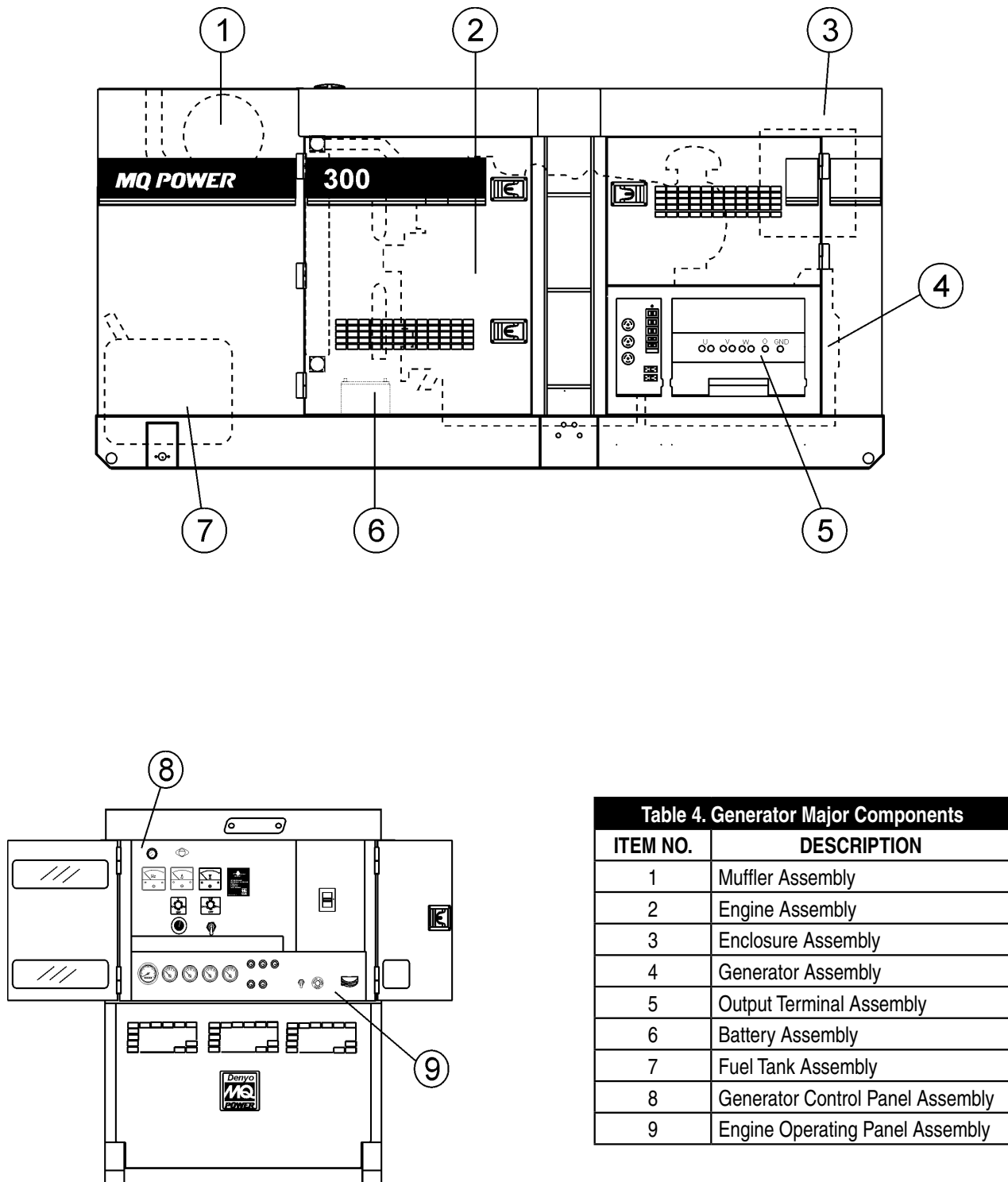

Figure 3. Major Components

GENERATOR CONTROL PANEL

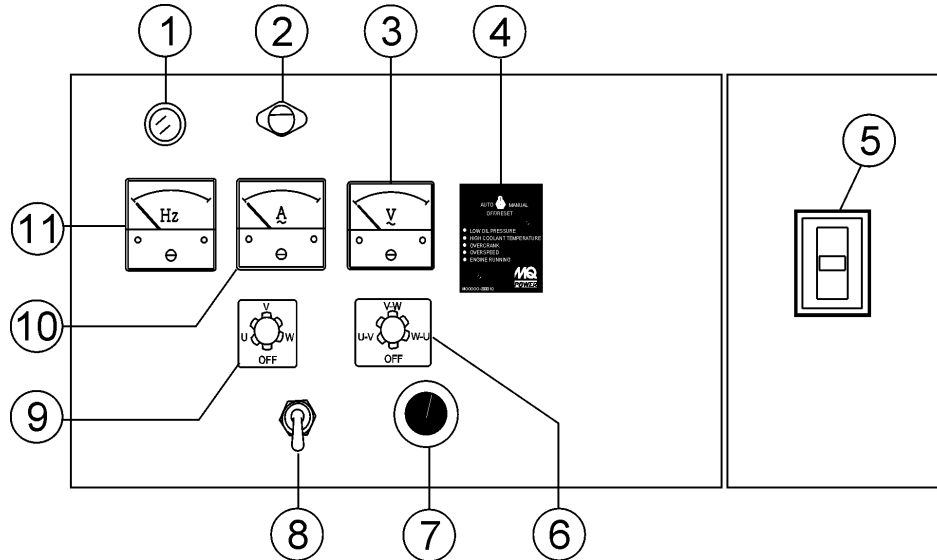
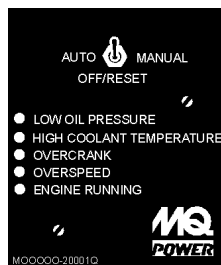

Figure 4. Generator Control Panel

The definitions below describe the controls and functions of the Generator Control Panel (Figure 4).

1. **Pilot Lamp** — Indicates the system is running.
2. **Panel Light** — Normally used in dark areas or at night time. When activated, panel lights will illuminate. When the generator is not in use be sure to turn the panel light switch to the **OFF** position.
3. **AC Voltmeter** — Indicates the output voltage present at the **U,V, and W Output Terminal Lugs**.
4. **Auto On/Off Engine Controller (MPEC)** —

This controller has a vertical row of status LED's (inset), that when lit, indicate that an engine malfunction (fault) has been detected. When a fault has been detected the engine controller will evaluate the fault and all major faults will shutdown the generator. During **cranking cycle**, The MPEC will attempt to crank the engine for 10 seconds before disengaging.



If the engine does not engage (start) by the third attempt, the engine will be shutdown by the engine controller's **Over Crank Protection** mode. If the engine engages at a speed (RPM's) that is not safe,

the controller will shutdown the engine by initializing the **Over Speed Protection** mode.

5. **Main Circuit Breaker** — This three-pole, 800 amp main breaker is provided to protect the **U,V, and W Output Terminal Lugs** from overload.
6. **Voltmeter Change-Over Switch** — This switch allows the AC voltmeter to indicate phase to phase voltage between any two phases of the output terminals or to be switched off.
7. **Voltage Regulator Control** — Allows $\pm 15\%$ manual adjustment of the generator's output voltage.
8. **Panel Light Switch** — When activated will turn on control panel light.
9. **Ammeter Change-Over Switch** — This switch allows the AC ammeter to indicate the current flowing to the load connected to any phase of the output terminals, or to be switched off. This switch does not effect the generator output in any fashion, it is for current reading only.
10. **AC Ammeter** — Indicates the amount of current the load is drawing from the generator per leg selected by the ammeter phase-selector switch.
11. **Frequency Meter** — Indicates the output frequency in hertz (Hz). Normally 60 Hz

GENERATOR CONTROL PANEL

■ **MPEC Control Switch** — This switch controls the running of the unit. If this switch is set to the **OFF/RESET** position, the unit will not run. When this switch is set to the manual position, the generator will start immediately.

If the generator is to be connected to a building's AC power source via a transfer switch (isolation), place the switch in the AUTO position. In this position, should an outage occur, the automatic transfer switch (ATS) will start the generator automatically via the generator's auto-start contacts connected to the ATS's start contacts. Please refer to your ATS installation manual for further instructions for the correct installation of the auto-start contacts of the generator to the ATS.

■ **Low Oil Pressure** — Indicates the engine pressure has fallen below a safe operating level. The oil pressure is detected using variable resistive values from the oil pressure sending unit. This is considered a **major** fault.

■ **High Coolant Temperature** — Indicates the engine temperature has exceeded a safe operating level. The engine temperature is detected using variable resistive values from the temperature sending unit. This is considered a **major** fault.

■ **Overcrank Shutdown** — Indicates the unit has attempted to start a pre-programmed number of times and has failed to start. The number of cycles and duration are programmable. It is pre-set at 3 cycles with a 10-second duration. This is considered a **major** fault.

■ **Overspeed Shutdown** — Indicates the engine is running at an unsafe speed. This is considered a **major** fault.

■ **Engine Running** — Indicates that engine is running at a safe operating speed.

Located behind the generator control panel is the **Generator Control Box**. This box contains some of the necessary electronic components required to make the generator function.

The **Control Box** is equipped with the following major components:

- Over-Current Relay
- Voltage Rectifier (AVR)
- Starter Relay
- Current Transformer
- Voltage Change-Over Board
- Three Phase Circuit Breaker

NOTICE

Remember the **overcurrent relay** monitors the current flowing from the **U,V, and W Output Terminal Lugs** to the load.

In the event of a short circuit or over current condition, it will automatically trip the 800 amp main breaker.

To restore power to the **Output Terminal Panel**, press the reset button on the overcurrent relay and place the **main** circuit breaker in the **closed** position (**ON**).

ENGINE OPERATING PANEL

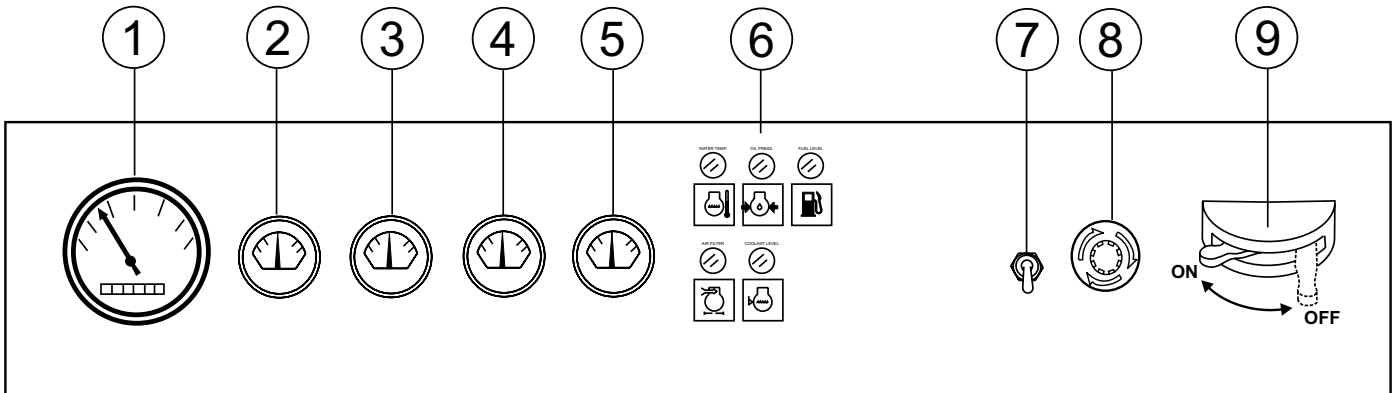







Figure 5. Engine Operating Panel

The definitions below describe the controls and functions of the Engine Operating Panel (Figure 5).

1. **Tachometer** — Indicates engine speed in RPM's for 60 Hz operation. This meter should indicate 1800 RPM's when the rated load is applied. In addition a built in hour meter will record the number of operational hours that the generator has been in use.
2. **Oil Pressure Gauge** — During normal operation this gauge be should read between 28 to 85 psi. (193~586 kPa). When starting the generator the oil pressure may read a little higher, but after the engine warms up the oil pressure should return to the correct pressure range.
3. **Water Temperature Gauge** — During normal operation this gauge be should read between 167° and 203°F (75°~95°C).
4. **Charging Ammeter Gauge** — Indicates the current being supplied by the engine's alternator which provides current for generator's control circuits and battery charging system.
5. **Fuel Gauge** — Indicates amount of diesel fuel available.
6. **Engine Warning Lamps** — There are three engine warning lamps, they are defined as follows:
 - a. **Overheat Lamp** — This lamp goes **ON** when the cooling water temperature rises abnormally. If the lamp goes **ON** during normal operation of the generator, the emergency shutdown device will stop the engine automatically.  WATER TEMP.
 - b. **Low Oil Pressure Lamp** — During normal operation of the generator this lamp should remain **OFF**. When the **Auto-OFF/Reset-Manual** switch is set  OIL PRESS.

to the **MANUAL** position to start the engine, the lamp will be lit. When the oil pressure rises after start-up the lamp will go **OFF**. If this lamp is ever lit (**ON**) during normal operation of the generator, the emergency shutdown device will stop the engine automatically.

- c. **Low Fuel Level Lamp** — When this lamp is **ON**, it is time to stop the engine and add fuel. Remember to let the engine cool before adding fuel (DCA300SSC only).  FUEL LEVEL
 - d. **Air Filter Alarm** — When the air filter element is clogged, this lamp goes **ON** indicating the element should be immediately cleaned or replaced.  AIR FILTER
 - e. **Coolant Level Alarm** — This lamp goes **ON** when the coolant level is low. If this lamp goes **ON** while the engine is in operation, the emergency shutdown device will automatically stop the engine.  COOLANT LEVEL
7. **Engine Speed Switch** — This switch controls the speed of the engine (low/high).
 8. **Pre-Heat Lamp** — When ECU is placed in **AUX** position, pre-heat lamp will be **ON**. When pre-heat cycle is completed, lamp will turn **OFF**.
 9. **Emergency Stop Button** — Push this button inward to stop the engine in the event of an emergency. **DO NOT** use this button as a means of stopping the engine.
 10. **Battery Switch** — This switch should be set to the **ON** position during normal operation. When the engine has been stop, place this switch in the **OFF** position. **DO NOT** turn this switch during normal operation, it could cause damage to the electrical equipment.

OUTPUT TERMINAL PANEL FAMILIARIZATION

OUTPUT TERMINAL PANEL

The Output Terminal Panel (Figure 6) shown below is located on the right-hand side (left from control panel) of the generator. Lift up on the cover to gain access to receptacles and terminal lugs.

NOTICE

Terminal legs "O" and "Ground" are considered bonded grounds

OUTPUT TERMINAL FAMILIARIZATION

The "Output Terminal Panel" (Figure 6) is provided with the following:

- Three (3) 240/139V output receptacles @ 50 amp
- Three (3) Circuit Breakers @ 50 amps
- Two (2) 120V GFCI receptacles @ 20 amp
- Two (2) GFCI Circuit Breakers @ 20 amps
- Eight (8) Output Terminal Lugs (U, V, W, O, Ground)

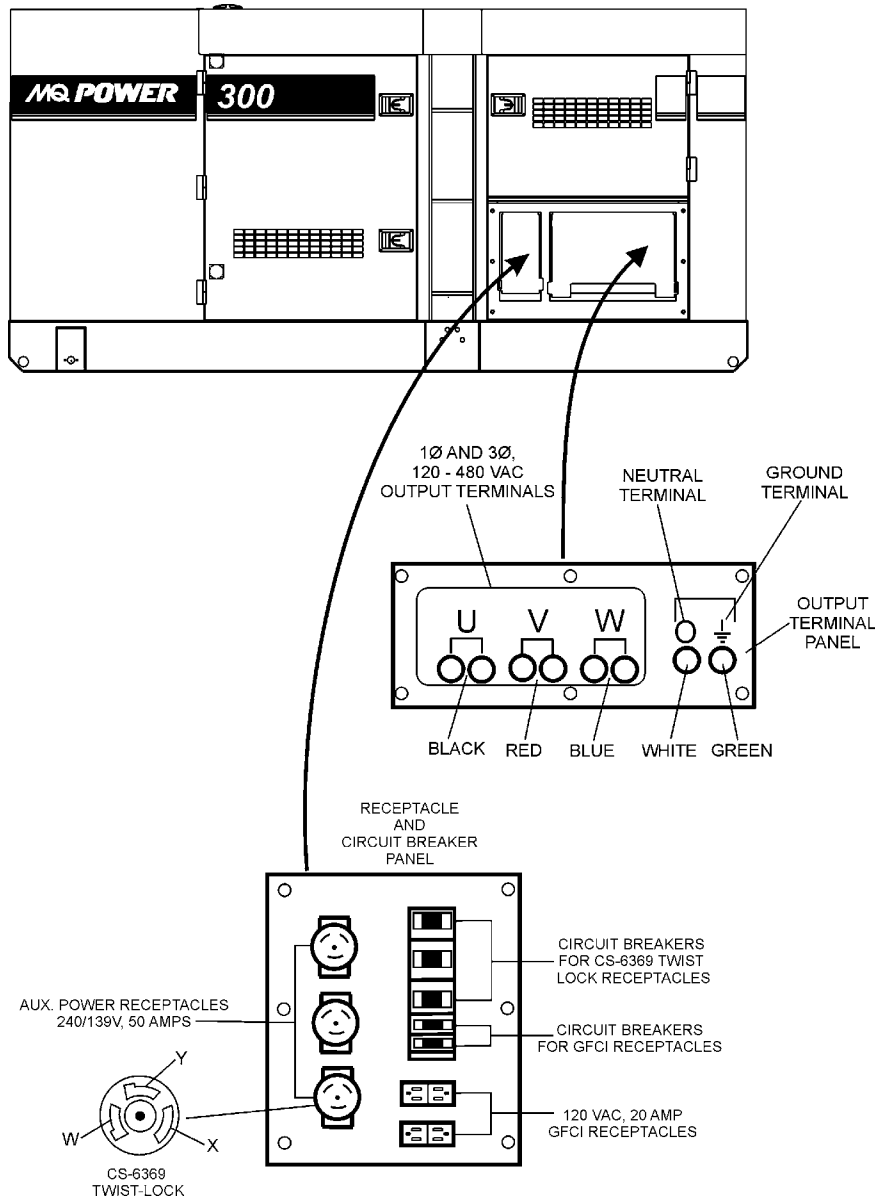

Figure 6. Output Terminal Panel

OUTPUT TERMINAL PANEL FAMILIARIZATION

120 VAC GFCI Receptacles

There are two 120 VAC, 20 amp GFCI (Duplex Nema 5-20R) receptacles provided on the output terminal panel. These receptacles can be accessed in any **voltage change-over board** configuration. Each receptacle is protected by a 20 amp circuit breaker. These breakers are located directly above the GFCI receptacles. Remember the load output (current) of both GFCI receptacles is dependent on the load requirements of the U, V, and W output terminal lugs.

Pressing the **reset** button resets the GFCI receptacle after being tripped. Pressing the **test button** (See Figure 7) in the center of the receptacle will check the GFCI function. Both receptacles should be tested at least once a month.

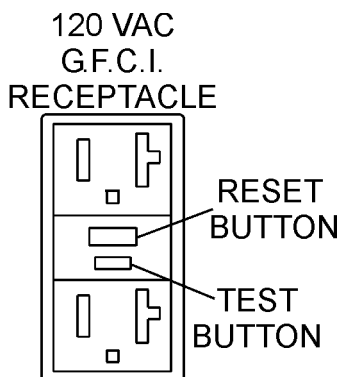

Figure 7. G.F.C.I. Receptacle

Twist Lock Dual Voltage 120/240 VAC Receptacles

There are three 120/240V, 50 amp auxiliary twist-lock (CS-6369) receptacles (Figure 8) provided on the output terminal panel. These receptacles can **only** be accessed when the voltage change-over board is configured for **single-phase 240/120** application

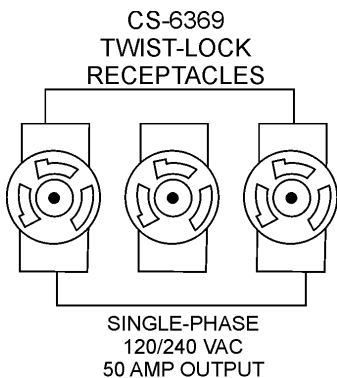

Figure 8. 120/240V Twist-Lock Auxiliary Receptacles

Each auxiliary receptacle is protected by a 50 amp circuit breaker. These breakers are located directly above the GFCI receptacles. Remember the load output (current) on all three receptacles is dependent on the load requirements of the **output terminal lugs**.

Turn the **voltage regulator control knob** (Figure 9) on the control panel to obtain the desired voltage. Turning the knob clockwise will **increase** the voltage, turning the knob counter-clockwise will **decrease** the voltage.

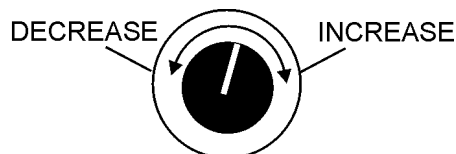

Figure 9. Voltage Regulator Control Knob

OUTPUT TERMINAL PANEL FAMILIARIZATION

Connecting Loads

Loads can be connected to the generator by the **Output Terminal Lugs** or the convenience receptacles (Figure 10). Make sure to read the operation manual before attempting to connect a load to the generator.

To protect the output terminals from overload, a 3-pole, 800A **main** circuit breaker is provided. Make sure to switch **ALL** circuit breakers to the **OFF** position prior to starting the engine.

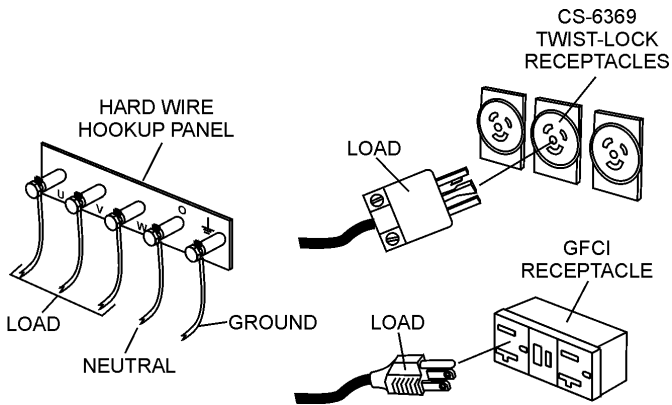

Figure 10. Connecting Loads

Over Current Relay

An **over current relay** (Figure 11) is connected to the main circuit breaker. In the event of an overload, both the circuit breaker and the over current relay may trip. If the circuit breaker can not be reset, the **reset button** on the over current relay must be pressed. The over current relay is located in the control box.

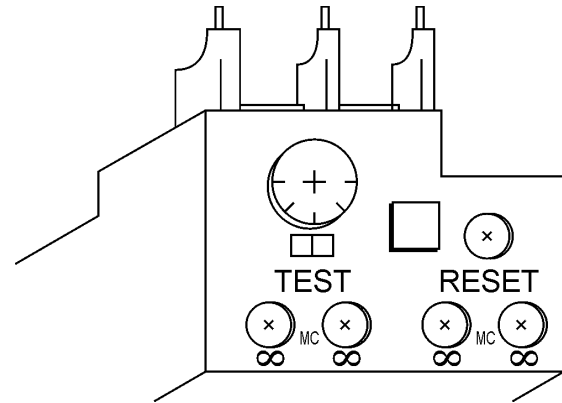

Figure 11. Over Current Relay

LOAD APPLICATION

SINGLE PHASE LOAD

Always be sure to check the nameplate on the generator and equipment to insure the wattage, amperage, frequency, and voltage requirements are satisfactorily supplied by the generator for operating the equipment.

Generally, the wattage listed on the nameplate of the equipment is its rated output. Equipment may require 130—150% more wattage than the rating on the nameplate, as the wattage is influenced by the efficiency, power factor and starting system of the equipment.

NOTICE

If wattage is not given on the equipment's name plate, approximate wattage may be determined by multiplying nameplate voltage by the nameplate amperage.

$$\text{WATTS} = \text{VOLTAGE} \times \text{AMPERAGE}$$

The power factor of this generator is 0.8. See Table 5 below when connecting loads.

Table 5. Power Factor By Load

Type of Load	Power Factor
Single-phase induction motors	0.4-0.75
Electric heaters, incandescent lamps	1.0
Fluorescent lamps, mercury lamps	0.4-0.9
Electronic devices, communication equipment	1.0
Common power tools	0.8

Table 6. Cable Selection (60 Hz, Single Phase Operation)

Current in Amperes	Load in Watts		Maximum Allowable Cable Length			
	At 100 Volts	At 200 Volts	#10 Wire	#12 Wire	#14 Wire	#16 Wire
2.5	300	600	1000 ft.	600 ft.	375 ft.	250 ft.
5	600	1200	500 ft.	300 ft.	200 ft.	125 ft.
7.5	900	1800	350 ft.	200 ft.	125 ft.	100 ft.
10	1200	2400	250 ft.	150 ft.	100 ft.	
15	1800	3600	150 ft.	100 ft.	65 ft.	
20	2400	4800	125 ft.	75 ft.	50 ft.	

CAUTION: Equipment damage can result from low voltage

THREE PHASE LOAD

When calculating the power requirements for 3-phase power use the following equation:

$$\text{KVA} = \frac{\text{VOLTAGE} \times \text{AMPERAGE} \times 1.732}{1000}$$

NOTICE

If 3Ø load (kVA) is not given on the equipment nameplate, approximate 3Ø load may be determined by multiplying voltage by amperage by 1.732

NOTICE

Motors and motor-driven equipment draw much greater current for starting than during operation.

An inadequate size connecting cable which cannot carry the required load can cause a voltage drop which can burn out the appliance or tool and overheat the cable. See Table 6.

- When connecting a resistance load such as an incandescent lamp or electric heater, a capacity of up to the generating set's rated output (kW) can be used.
- When connecting a fluorescent or mercury lamp, a capacity of up to the generating set's rated output (kW) multiplied by 0.6 can be used.
- When connecting an electric drill or other power tools, pay close attention to the required starting current capacity.

When connecting ordinary power tools, a capacity of up to the generating set's rated output (kW) multiplied by 0.8 can be used.

DANGER

Before connecting this generator to any building's electrical system, a **licensed electrician** must install an **isolation (transfer) switch**. Serious damage to the building's electrical system may occur without this transfer switch.

GENERATOR OUTPUTS

GENERATOR OUTPUT VOLTAGES

A wide range of voltages are available to supply voltage for many different applications. Voltages are selected by applying jumpers (6) to the **voltage change-over board** (Figure 12). To obtain some of the voltages as listed in Table 7 (see below) will require a fine adjustment using the **voltage regulator (VR) control knob** located on the control panel.

Voltage Change-Over Board

The **voltage change-over board** (Figure 12) is located on the control box, behind the generator control panel. This board has been provided for ease of voltage selection.

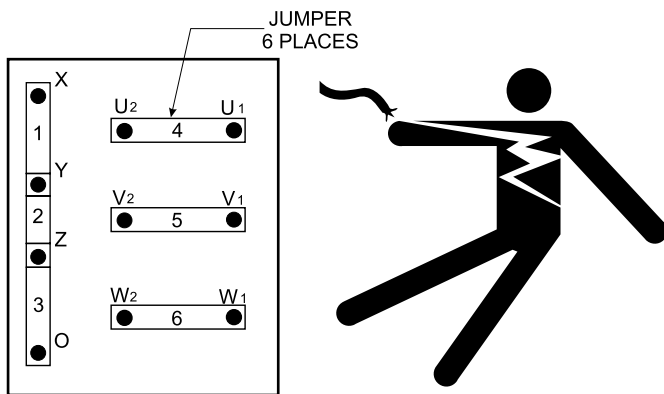

Figure 12. Voltage Change-Over Board

CAUTION

NEVER attempt to place jumper plates on the **voltage change-over board** while the generator is in operation. There exist the possibility of **electrocution, electrical shock or burn, which can cause severe bodily harm or even death!**

Table 7. Voltages Available						
UVWO Output Terminal Lugs	Voltage Change-Over Board 3-Phase 240/139V Position			Voltage Change-Over Board 3-Phase 480/270V Position		
	3Ø Line-Line	208V	220V	240V	416V	440V
1Ø Line-Neutral	120V	127V	139V	240V	254V	277V
Voltage Change-Over Board Single-Phase 240/120V Position						
1Ø Line-Neutral/ Line-Line	120V Line-Neutral	N/A	N/A	240V Line-Line	N/A	N/A

Maximum Amps

Table 8 shows the **maximum** amps the generator can provide. **DO NOT** exceed the maximum amps as listed.

Table 8. Generator Maximum Amps	
Model	DCA300SSC DCA300SSCU
Rated Voltage	Maximum Amps
Single Phase 120 Volt	666.7 amps (4 wire)
Single Phase 240 Volt	333.3 amps (4 wire)
Three Phase 240 Volt	722 amps
Three Phase 480 Volt	361 amps

GENERATOR OUTPUTS/GAUGE READING

HOW TO READ THE AC AMMETER AND AC VOLTAGE GAUGES

The AC ammeter and AC voltmeter gauges are controlled by the AC ammeter and AC voltmeter change-over switches.

Both of these switches are located on the control panel and **DO NOT** effect the generator output. They are provided to help observe how much power is being supplied, produced at the UVWO terminals lugs.

Before taking a reading from either gauge, configure the **Voltage Change-Over Board** (Figure 13) which produces the desired output voltage.

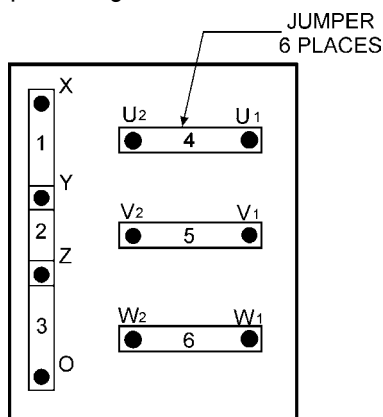

Figure 13. Voltage Change-Over Board
240/3Ø Position

AC Voltmeter Gauge Reading

Place the **AC Voltmeter Change-Over Switch** (Figure 14) in the W-U position and observe the phase to phase voltage reading between the W and U terminals as indicated on the **AC Voltmeter Gauge** (Figure 15).

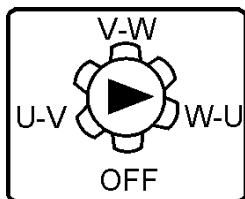

Figure 14. AC Voltmeter
Change-Over Switch

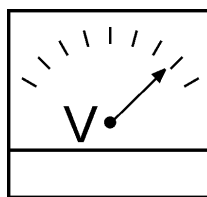

Figure 15. AC Voltmeter Gauge
(Volt reading on W-U Lug)

AC Ammeter Gauge Reading

Place the **AC Ammeter Change-Over Switch** (Figure 16) in the U position and observe the current reading (load drain) on the U terminal as indicated on the **AC Ammeter Gauge** (Figure 17). This process can be repeated for terminals V and W.

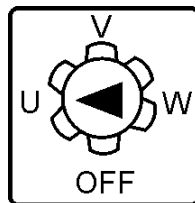

Figure 16. AC Ammeter
Change-Over Switch

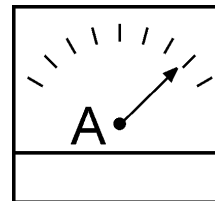

Figure 17. AC Ammeter
(Amp reading on U Lug)

NOTICE

The **ammeter** gauge will only show a reading when the **Output Terminal Lugs** are connected to a load and in use.

OUTPUT TERMINAL PANEL CONNECTIONS

UVWO TERMINAL OUTPUT VOLTAGES

Various output voltages can be obtained using the UVWO output terminal lugs. The voltages at the terminals are dependent on the placement of the jumpers plates (6) on the **Voltage Change-Over Board** and the adjustment of the **Voltage Regulator Control Knob**.

Remember the voltage change-over board determines the **range** of the output voltage and can be configured in two different positions that provide 6 different output voltages at the UVWO output terminals. The generator is shipped from the factory in the 240V configuration. The voltage regulator (VR) allows the user to increase or decrease the selected voltage.

3Ø-240V UVWO Terminal Output Voltages

1. Jumper the voltage change-over board for 240V operation as shown in Figure 18.

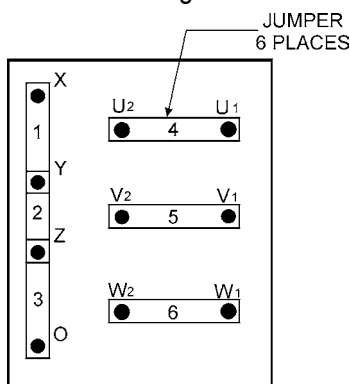

Figure 18. Voltage Change-Over Board 240V Configuration

2. Connect the load wires to the UVWO terminals as shown in Figure 19.

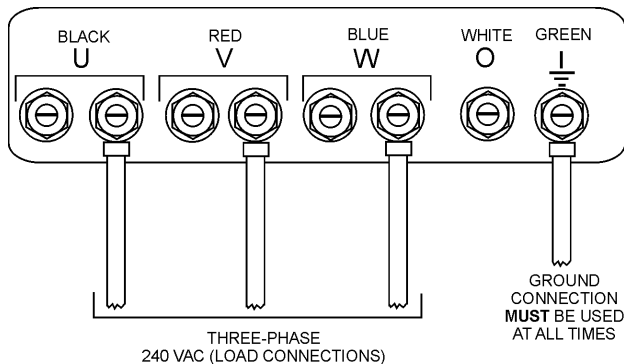

Figure 19. UVWO Terminal Lugs

3. Turn the voltage regulator knob (Figure 20) clockwise to increase voltage output, turn counterclockwise to decrease voltage output. Use voltage regulator adjustment knob whenever fine tuning of the output voltage is required



Figure 20. Voltage Regulator Knob

1Ø-240V UVWO Terminal Output Voltages

1. Make sure the voltage change-over board is jumpered for 240V operation as shown in Figure 18.
2. Connect the load wires to the UVWO terminals as shown in Figure 21.

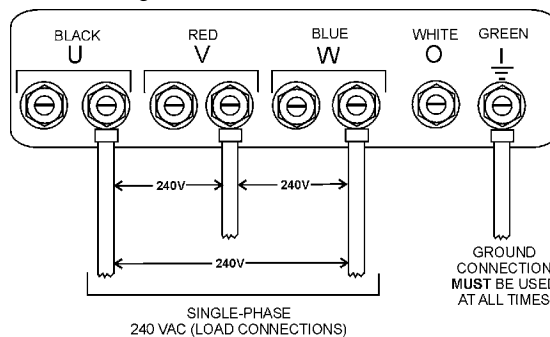

Figure 21. UVWO Terminal Lugs 1Ø-240V Connections

1Ø-120V UVWO Terminal Output Voltages

1. Make sure the voltage change-over board is jumpered for 240V operation as shown in Figure 18.
2. Adjust voltage regulator knob (Figure 20) for an output of 208V to obtain 120V at the UVWO terminals.
3. Connect the load wires to the UVWO terminals as shown in Figure 22.

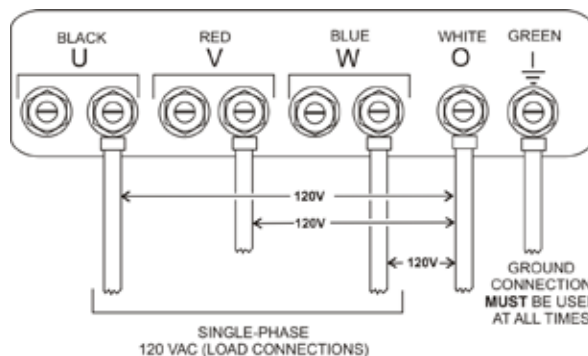

Figure 22. UVWO Terminal Lugs 1Ø-120V Connections

OUTPUT TERMINAL PANEL CONNECTIONS

3Ø-480V UVWU Terminal Output Voltages

1. Jumper the voltage change-over board for 480V operation as shown in Figure 23. This configuration uses 6 jumper plates in 3 different positions. Remember there are 2 jumper plates at every position. Every jumper plate **must** be used.

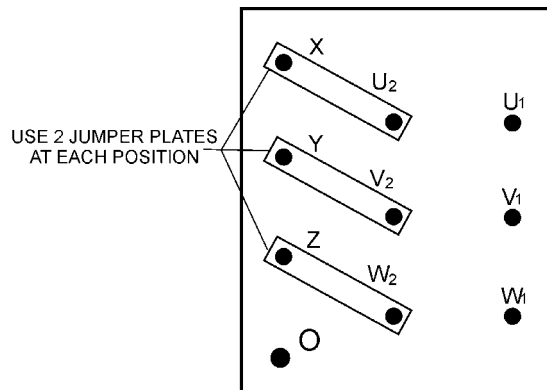

Figure 23. Voltage Change-Over Board 480V Configuration

2. Connect the load wires to the UVWU terminals as shown in Figure 24.

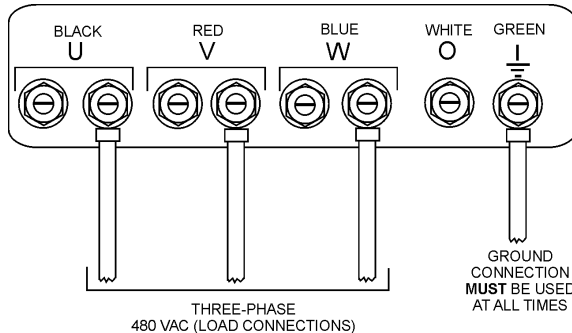

Figure 24. UVWU Terminal Lugs 3Ø-480V Connections

NOTICE

ALWAYS make sure that the connections to the UVWU terminals are **secure** and **tight**. The possibility of arcing exists, that could cause a fire.

1Ø-480V UVWU Terminal Output Voltages

1. Make sure the voltage change-over board is jumpered for 480V operation as shown in Figure 23.
2. Connect the load wires to the UVWU terminals as shown in Figure 25.

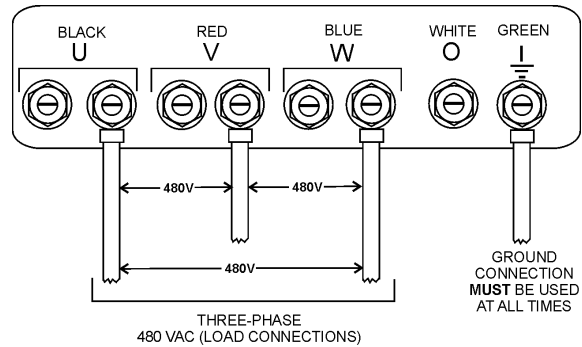

Figure 25. UVWU Terminal Lugs 1Ø-480V Connections

1Ø-277V UVWU Terminal Output Voltages

1. Make sure the voltage change-over board is jumpered for 480V operation as shown in Figure 23.
2. Connect the load wires to the UVWU terminals as shown in Figure 26.

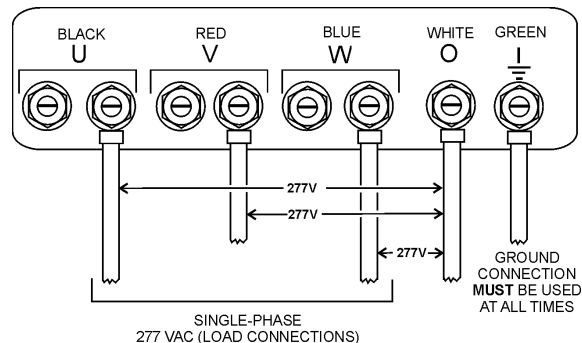

Figure 26. UVWU Terminal Lugs 1Ø-277V Connections

CIRCUIT BREAKERS

To protect the generator from an overload, a 3-pole, 800 amp, main circuit breaker is provided to protect the **U, V, and W Output Terminals** from overload. In addition two single-pole, 20 amp **GFCI** circuit breakers are provided to protect the GFCI receptacles from overload. Three 50 amp **load** circuit breakers have also been provided to protect the auxiliary receptacles from overload. Make sure to switch **ALL** circuit breakers to the **OFF** position prior to starting the engine.

LUBRICATION OIL

Fill the engine crankcase with lubricating oil through the filler hole, but **DO NOT** overfill. Make sure the generator is level and verify that the oil level is maintained between the two notches (Figure 27) on the dipstick. See Table 9 for proper selection of engine oil.

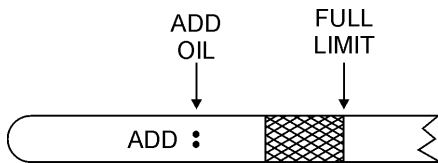

Figure 27. Engine Oil Dipstick

When checking the engine oil, be sure to check if the oil is clean. If the oil is not clean, drain the oil by removing the oil drain plug, and refill with the specified amount of oil as outlined in the **Cummins Engine Owner's Manual**. Oil should be warm before draining.

Other types of motor oils may be substituted if they meet the following requirements:

- API Service Classification CC/SC
- API Service Classification CC/SD
- API Service Classification CC/SE
- API Service Classification CC/SF

Table 9. Recommended Motor Oil		OIL: SAE	
°F	°C	SAE	SAE
122	50	10W/40	10W/40
104	40	10W/40	30
86	30	10W/40	15W/30
68	20	10W/40	10W/30
50	10	10W/40	10W
32	0	10W/40	20W/40
-14	-10	ARCTIC OIL	5W/30
-4	-20	ARCTIC OIL	
-22	-30	ARCTIC OIL	
-40	-40	ARCTIC OIL	

FUEL CHECK

! DANGER



Fuel spillage on a **hot** engine can cause a **fire** or **explosion**. If fuel spillage occurs, wipe up the spilled fuel completely to prevent fire hazards. **NEVER** smoke around or near the generator.

Refilling the Fuel System

! CAUTION

ONLY properly trained personnel who have read and understand this section should refill the fuel tank system.

This generator has an internal fuel tank located inside the trailer frame and may also be equipped with an environmental fuel tank (Figure 28). **ALWAYS** fill the fuel tanks with clean fresh **#2 diesel fuel**. **DO NOT** fill the fuel tanks beyond their capacities.

Pay attention to the fuel tank capacity when replenishing fuel. The fuel tank cap must be closed tightly after filling. Handle fuel in a safety container. If the container does not have a spout, use a funnel. Wipe up any spilled fuel immediately.

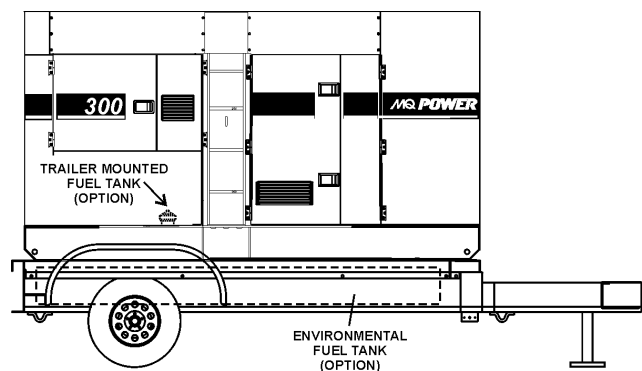

Figure 28. Internal Fuel Tank System

Refueling Procedure:

WARNING



Diesel fuel and its vapors are dangerous to your health and the surrounding environment. Avoid skin contact and/or inhaling fumes.

1. **Level Tanks** — Make sure fuel cells are level with the ground. Failure to do so will cause fuel to spill from the tank before reaching full capacity (Figure 29).

CAUTION

ALWAYS place trailer on firm level ground before refueling to prevent spilling and maximize the amount of fuel that can be pumped into the tank.

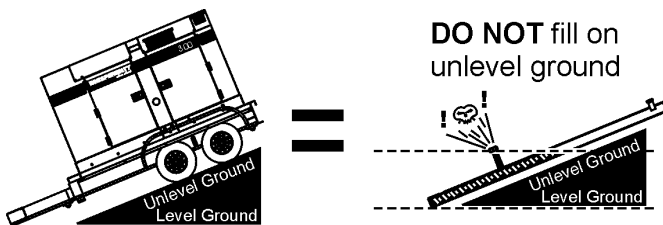

Figure 29. Only Fill on Level Ground

NOTICE

ONLY use #2 diesel fuel when refueling.

2. Open cabinet doors on the “right side” of the generator (from generator control panel position). Remove fuel cap and fill tank (Figure 30).

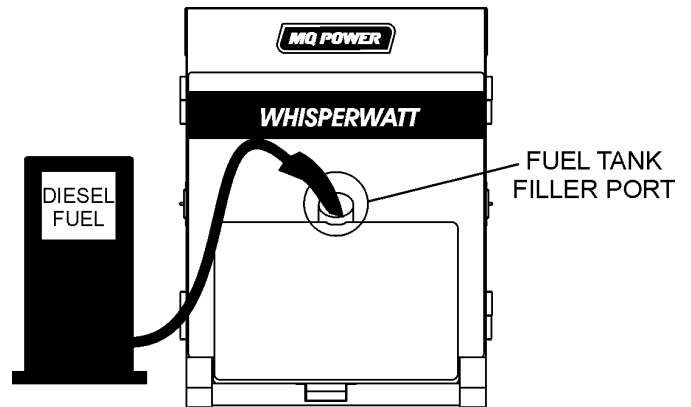

Figure 30. Fueling the Generator

3. **NEVER overfill fuel tank** — It is important to read the fuel gauge when filling trailer fuel tank. **DO NOT** wait for fuel to rise in filler neck (Figure 31).

FUEL GAUGE LOCATED ON CONTROL PANEL

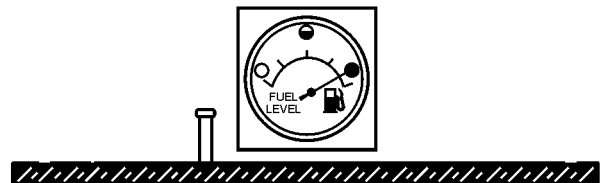

Figure 31. Full Fuel Tank

CAUTION

DO NOT OVERFILL fuel system. Leave room for fuel expansion. Fuel expands when heated (Figure 32).



Figure 32. Fuel Expansion

COOLANT (ANTIFREEZE/SUMMER COOLANT/WATER)

Cummins recommends antifreeze/summer coolant for use in their engines, which can be purchased in concentrate (and mixed with 50% demineralized water) or pre-diluted. See the **Cummins Engine Owner's Manual** for further details.

WARNING



If adding coolant/antifreeze mix to the radiator, **DO NOT** remove the radiator cap until the unit has completely cooled. The possibility of **hot!** coolant exists which can cause severe burns.

Day-to-day addition of coolant is done from the recovery tank. When adding coolant to the radiator, **DO NOT** remove the radiator cap until the unit has completely cooled. See Table 10 for engine, radiator, and recovery tank coolant capacities. Make sure the coolant level in the recovery tank is always between the "H" and the "L" markings.

Table 10. Coolant Capacity	
Engine and Radiator	15.8 Gal (60 liters)
Reserve Tank	N/A

Operation in Freezing Weather

When operating in freezing weather, be certain the proper amount of antifreeze (Table 11) has been added.

Table 11. Anti-Freeze Operating Temperatures		
Vol % Anti-Freeze	Freezing Point	
	°C	°F
50	-37	-34

NOTICE

When the antifreeze is mixed with water, the antifreeze mixing ratio **must be** less than 50%.

Cleaning the Radiator

The engine may overheat if the radiator fins become overloaded with dust or debris. Periodically clean the radiator fins with compressed air. Cleaning inside the machine is dangerous, so clean only with the engine turned off and the **negative** battery terminal disconnected.

AIR CLEANER

Periodic cleaning/replacement is necessary. Inspect air cleaner in accordance with the **Cummins Engine Owner's Manual**.

FAN BELT TENSION

A slack fan belt may contribute to overheating, or to insufficient charging of the battery. Inspect the fan belt for damage and wear and adjust it in accordance with the **Cummins Engine Owner's Manual**.

The fan belt tension is proper if the fan belt bends 10 to 15 mm (Figure 33) when depressed with the thumb as shown below.

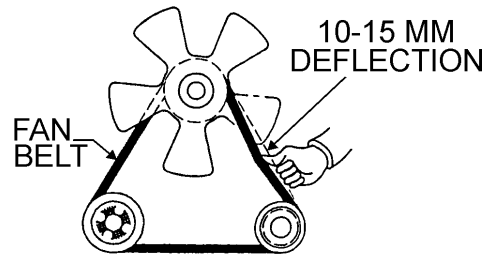



Figure 33. Fan Belt Tension

CAUTION



NEVER place hands near the belts or fan while the generator set is running.

BATTERY

This unit is of negative ground **DO NOT** connect in reverse. Always maintain battery fluid level between the specified marks. Battery life will be shortened, if the fluid level are not properly maintained. Add only distilled water when replenishment is necessary.

DO NOT over fill. Check to see whether the battery cables are loose. Poor contact may result in poor starting or malfunctions. **Always** keep the terminals firmly tightened. Coating the terminals with an approved battery terminal treatment compound. Replace battery with only recommended type battery. The battery type used in this generator is BCI Group 27.

The battery is sufficiently charged if the specific gravity of the battery fluid is 1.28 (at 68° F). If the specific gravity should fall to 1.245 or lower, it indicates that the battery is dead and needs to be recharged or replaced.

Before charging the battery with an external electric source, be sure to disconnect the battery cables.

Battery Cable Installation

ALWAYS be sure the battery cables (Figure 34) are properly connected to the battery terminals as shown below. The **red cable** is connected to the positive terminal of the battery, and the **black cable** is connected to the negative terminal of the battery.

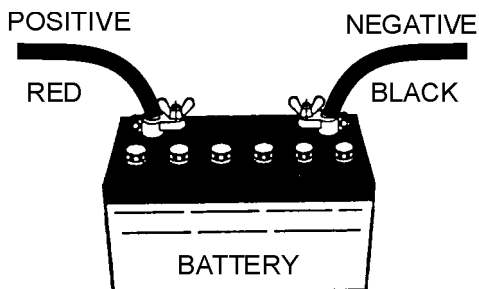
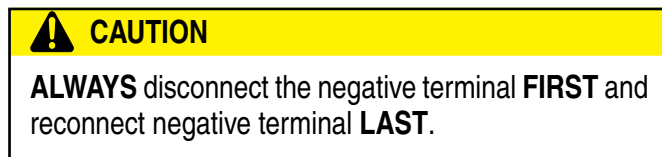

Figure 34. Battery Connections

When connecting battery do the following:

1. **NEVER** connect the battery cables to the battery terminals when the **MPEC Control Switch** is in either the **MANUAL** position. **ALWAYS** make sure that the **MPEC Control Switch** is in the **OFF/RESET** position when connecting the battery.
2. Place a small amount of battery terminal treatment compound around both battery terminals. This will ensure a good connection and will help prevent corrosion around the battery terminals.

NOTICE

If the battery cable is connected incorrectly, electrical damage to the generator will occur. Pay close attention to the polarity of the battery when connecting the battery.

CAUTION

Inadequate battery connections may cause poor starting of the generator, and create other malfunctions.

ALTERNATOR

The polarity of the alternator is negative grounding type. When an inverted circuit connection takes place, the circuit will be in short circuit instantaneously resulting the alternator failure.

DO NOT put water directly on the alternator. Entry of water into the alternator can cause corrosion and damage the alternator.

WIRING

Inspect the entire generator for bad or worn electrical wiring or connections. If any wiring or connections are exposed (insulation missing) replace wiring immediately.

PIPING AND HOSE CONNECTION

Inspect all piping, oil hose, and fuel hose connections for wear and tightness. Tighten all hose clamps and check hoses for leaks.

If any hose (**fuel or oil**) lines are defective replace them immediately.

GENERATOR START-UP PROCEDURE (MANUAL)

BEFORE STARTING

CAUTION

The engine's exhaust contains harmful emissions. **ALWAYS** have adequate ventilation when operating. Direct exhaust away from nearby personnel.

WARNING

NEVER manually start the engine with the main, GFCI or auxiliary circuit breakers in the **ON** (closed) position.

1. Place the **main, G.F.C.I., and aux.** circuit breakers (Figure 35) in the **OFF** position prior to starting the engine.

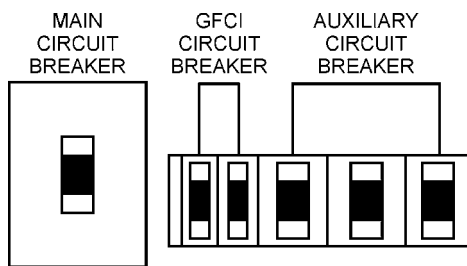

Figure 35. Main, Aux. and GFCI Circuit Breakers (OFF)

2. Make sure the **voltage change-over board** has been configured for the desired output voltage.
3. Connect the load to the **receptacles** or the **output terminal lugs** as shown in Figure 10. These load connection points can be found on the output terminal panel and the output terminal panel's hard wire hookup panel.
4. Tighten terminal nuts securely to prevent load wires from slipping out.
5. Close all engine enclosure doors (Figure 36).

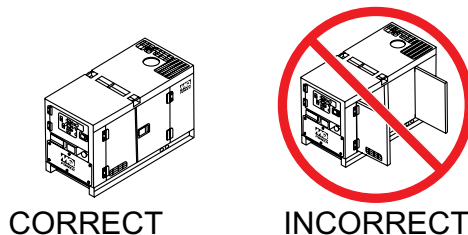

Figure 36. Engine Enclosure Doors

STARTING (MANUAL)

1. Place the engine speed switch (Figure 37) in the **LOW** (down) position.



Figure 37. Engine Speed Switch (Low)

2. Place the **MPEC control switch** in the **MANUAL** position to start the engine (Figure 38).

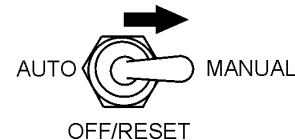

Figure 38. MPEC Control Switch (Manual Position)

3. Depending on the temperature of the coolant (cold weather conditions), the pre-heat lamp (Figure 39) will light (ON) and remain on until the pre-heating cycle has been completed. After completion of the pre-heating cycle, the light will go OFF and the engine will start up automatically.

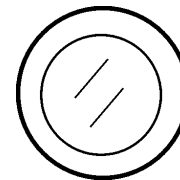

Figure 39. Pre-Heat Button

4. Once the engine starts, let the engine run for 1-2 minutes. Listen for any abnormal noises. If any abnormalities exist, shut down the engine and correct the problem. If the engine is running smoothly, place the engine speed switch (Figure 40) in the **HIGH** (up) position.



Figure 40. Engine Speed Switch (High)

5. Verify that the **engine running status LED** on the MPEC unit (Figure 41) is **ON** (lit) after the engine has been started.



Figure 41. Engine Running LED (ON)

GENERATOR START-UP PROCEDURE (MANUAL)

6. The generator's frequency meter (Figure 42) should be displaying the 60 cycle output frequency in **HERTZ**.

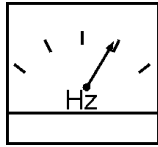

Figure 42. Frequency Meter

7. The generator's AC-voltmeter (Figure 43) will display the generator's output in **VOLTS**. If the voltage is not within the specified tolerance,

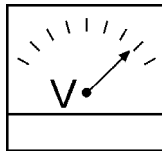

Figure 43. Voltmeter

8. Use the voltage adjustment control knob (Figure 44) to increase or decrease the desired voltage.

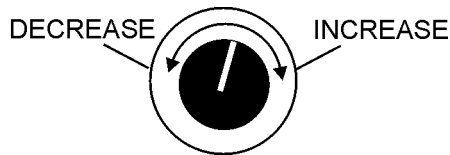

Figure 44. Voltage Adjust Control Knob

9. The ammeter (Figure 45) will indicate **zero amps** with no load applied. When a load is applied, the ammeter will indicate the amount of current that the load is drawing from the generator.

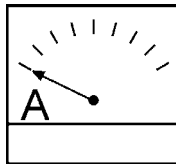

Figure 45. Ammeter (No Load)

10. The engine oil pressure gauge (Figure 46) will indicate the oil pressure of the engine. Under normal operating conditions the oil pressure is approximately 28 to 85 psi. (193~586 kPa).

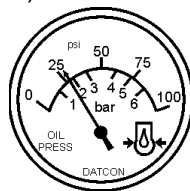

Figure 46. Oil Pressure Gauge

11. The **coolant temperature gauge** (Figure 47) will indicate the coolant temperature. Under normal operating conditions the coolant temperature should be between 167°~203°F (75°~95°C) (**Green Zone**).

Figure 47. Coolant Temperature Gauge

12. The **tachometer gauge** (Figure 48) will indicate the speed of the engine when the generator is operating. Under normal operating conditions this speed is approximately 1800 RPM's.

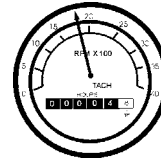

Figure 48. Engine Tachometer Gauge

13. Place the **main, GFCI, and aux.** circuit breakers in the **ON** position (Figure 49).

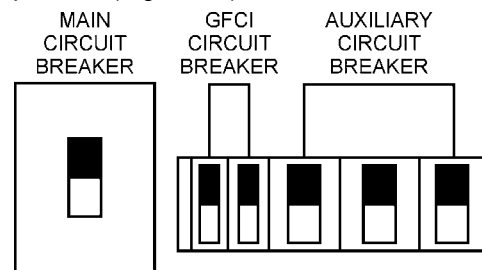

Figure 49. Main, Aux. and GFCI Circuit Breakers (ON)

14. Observe the generator's ammeter (Figure 50) and verify it reads the anticipated amount of current with respect to the load. The ammeter will only display a current reading if a load is in use.

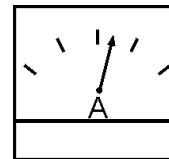

Figure 50. Ammeter (Load)

15. The generator will run until manually stopped or an abnormal condition occurs.

GENERATOR START-UP PROCEDURE (AUTO MODE)

STARTING (AUTO MODE)

DANGER



Before connecting this generator to any building's electrical system, a **licensed electrician** must install an **isolation (transfer) switch**. Serious damage to the building's electrical system may occur without this transfer switch.

CAUTION

When connecting the generator to a isolation (transfer) switch, **ALWAYS** have power applied to the generator's internal battery charger. This will ensure that the engine will not fail due to a dead battery.

NOTICE

When the generator is set in the **AUTO** mode, the generator will **automatically start** in the event of commercial power falling below a prescribed level by means of a contact closure that is generated automatically by a transfer switch.

WARNING

When running the generator in the **AUTO** mode, remember the generator can start up at any time without warning. **NEVER** attempt to perform any maintenance when the generator is in the auto mode.

CAUTION

The engine speed switch **must** be set to the "High" position when running in the **auto-start** mode. Failing to set the switch in the proper position can result in damage to your generator when it turns on.

NOTICE

When the MPEC control switch is placed in the **AUTO** position, the engine glow plugs will be warmed and the engine will start automatically.

When starting generator in **AUTO** mode use the "Manual Start-up" procedure except where noted (see below).

1. Perform steps 1 through 5 in the Before Starting section as outlined in the Manual Starting Procedure.
2. Place the **engine speed switch** (Figure 51) in the **HIGH** position

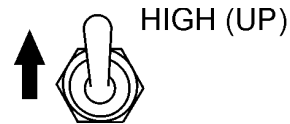

Figure 51. Engine Speed Switch (High)

3. Place the **MPEC Control Switch** (Figure 52) in the **AUTO** position.



Figure 52. MPEC Control Switch (AUTO)

4. Continue operating the generator as outlined in the Manual Start-up procedure (start at step 5).

GENERATOR SHUT-DOWN PROCEDURES

WARNING

NEVER stop the engine suddenly except in an emergency.

NORMAL SHUTDOWN PROCEDURE

To shutdown the generator, use the following procedure:

1. Place both the **MAIN, GFCI and LOAD** circuit breakers as shown in Figure 35 to the **OFF** position.
2. Place the engine speed switch (Figure 53) in the “LOW” (down) position.



Figure 53. Engine Speed Switch (Low)

3. Let the engine cool by running it at low speed for 3-5 minutes with no load applied.
4. Place the **MPEC Control Switch** (Figure 54) to the **OFF/RESET** position.



Figure 54. MPEC Control Switch (Off/Reset)

5. Verify that **all** the status LEDs on the MPEC display are **OFF** (not lit).
6. Remove all loads from the generator.
7. Inspect entire generator for any damage or loosening of components that may have occurred during operation.

EMERGENCY SHUTDOWN PROCEDURE

1. To stop the engine in the event of an emergency, **PUSH** the emergency stop button (Figure 55) inward. This button is located on the engine operating panel, see Figure 5.

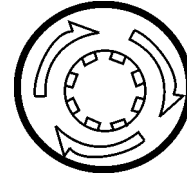

Figure 55. Emergency Stop Button

Table 12. Inspection/Maintenance		10 Hrs DAILY	250 Hrs	500 Hrs	1000 Hrs
Engine	Check Engine Fluid Levels	X			
	Check Air Cleaner	X			
	Check Battery Acid Level	X			
	Check Fan Belt Condition	X			
	Check for Leaks	X			
	Check for Loosening of Parts	X			
	Replace Engine Oil and Filter * 1		X		
	Clean Air Filter		X		
	Check Fuel Filter/Water Separator Bowl	X			
	Clean Unit, Inside and Outside		X		
	Change Fuel Filter			X	
	Clean Radiator and Check Coolant Protection Level*2			X	
	Replace Air Filter Element * 3			X	
	Check all Hoses and Clamps * 4				X
	Clean Inside of Fuel Tank				X
Generator	Measure Insulation Resistance Over 3M ohms		X		
	Check Rotor Rear Support Bearing			X	

*1 Replace engine oil and filter at 100 hours, first time only.

*2 Add "Supplemental Coolant Additives (SCA'S)" to recharge the engine coolant.

*3 Replace primary air filter element when restriction indicator shows a vacuum of 625 mm (25 in. H2O).

*4 If blowby hose needs to be replaced, ensure that the slope of the blowby hose is at least a 1/2 inch per foot, with no sags or dips that could collect moisture and/or oil.

GENERAL INSPECTION

Prior to each use, the generator should be cleaned and inspected for deficiencies. Check for loose, missing or damaged nuts, bolts or other fasteners. Also check for fuel, oil, and coolant leaks. Use Table 12 as a general maintenance guideline **Engine Side** (Refer to the Engine Instruction Manual)

AIR CLEANER

Every 250 hours: Remove air cleaner element (Figure 56) and clean the heavy duty paper element with light spray of compressed air. Replace the air cleaner as needed.

Air Cleaner with Dust Indicator

This indicator (Figure 56) is attached to the air cleaner. When the air cleaner element is clogged, air intake restriction becomes greater and the dust indicator signal shows **RED** meaning the element needs changing or service. After changing the air element, press the dust indicator button to reset the indicator.

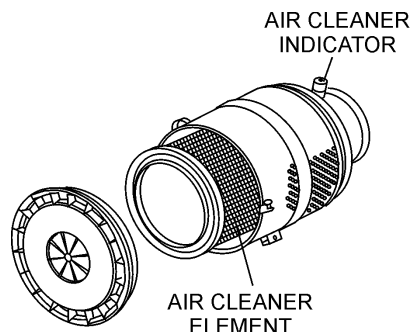

Figure 56. Air Cleaner/Indicator

NOTICE

The air filter should not be changed until the indicator reads "**RED**". Dispose of old air filter. It may not be cleaned or reused..

If the engine is operating in very **dusty** or **dry grass** conditions, a clogged air cleaner will result. This can lead to a loss of power, excessive carbon buildup in the combustion chamber and high fuel consumption. Change air cleaner more **frequently** if these conditions exist.

FUEL ADDITION

Add diesel fuel (the grade may vary according to season and locations).

Removing Water from the Fuel Tank

After prolonged use, water and other impurities accumulate in the bottom of the tank. Occasionally inspect the fuel tank for water contamination and drain the contents if required.

During cold weather, the more empty volume inside the tank, the easier it is for water to condense. This can be reduced by keeping the tank full with diesel fuel.

Cleaning Inside the Fuel Tank

Drain the fuel inside the fuel tank completely. Using a spray washer (Figure 57) wash out any deposits or debris that have accumulated inside the fuel tank.

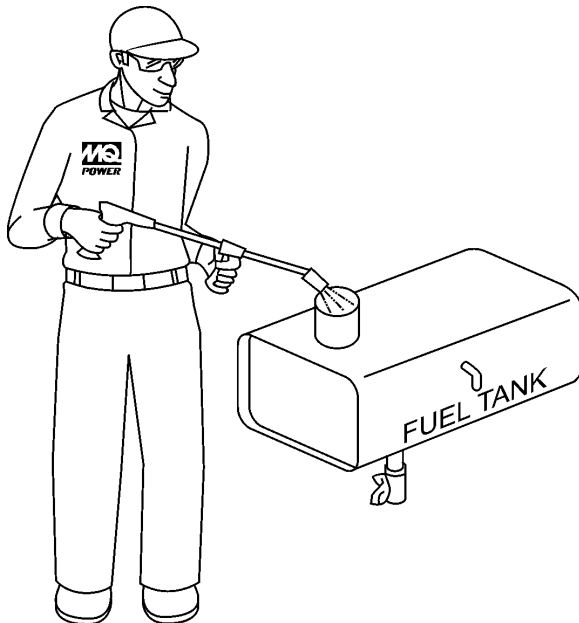

Figure 57. Fuel Tank Cleaning

FUEL TANK INSPECTION

In addition to cleaning the fuel tank, the following components should be inspected for wear:

- **Rubber Suspension** — look for signs of wear or deformity due to contact with oil. Replace the rubber suspension if necessary.
- **Fuel Hoses** — inspect nylon and rubber hoses for signs of wear, deterioration and hardening.
- **Fuel Tank Lining** — inspect the fuel tank lining for signs of excessive amounts of oil or other foreign matter.

Replacing Fuel Filter

- Replace the fuel filter cartridge with new one every 500 hours or so.
- Loosen the drain plug at the lower top of the fuel filter. Drain the fuel in the fuel body together with the mixed water. **DO NOT** spill the fuel during disassembly.
- Vent any air

AIR REMOVAL

If air enters the fuel injection system of a diesel engine, starting becomes impossible. After running out of fuel, or after disassembling the fuel system, bleed the system according to the following procedure. See the **Cummins Engine Manual** for details.

To restart after running out of fuel, turn the switch to the "ON" position for 15-30 seconds. Try again, if needed. This unit is equipped with an automatic air bleeding system.

CHECK OIL LEVEL

Check the crankcase oil level prior to each use, or when the fuel tank is filled. Insufficient oil may cause severe damage to the engine. Make sure the generator is level. The oil level must be between the two notches on the dipstick as shown in Figure 27.

Replacing Oil Filter

- Remove the old oil filter.
- Apply a film of oil to the gasket on the new oil filter.
- Install the new oil filter.
- After the oil cartridge has been replaced, the engine oil will drop slightly. Run the engine for a while and check for leaks before adding more oil if needed. Clean excessive oil from engine.

FLUSHING OUT RADIATOR AND REPLACING COOLANT

- Open both cocks located at the crankcase side and at the lower part of the radiator and drain coolant. Open the radiator cap while draining. Remove the overflow tank and drain.
- Check hoses for softening and kinks. Check clamps for signs of leakage.
- Tighten both cocks and replace the overflow tank.
- Replace with coolant as recommended by the engine manufacturer.
- Close radiator cap tightly.
- Flush the radiator by running clean tap water through radiator until signs of rust and dirt are removed. **DO NOT** clean radiator core with any objects, such as a screwdriver.

WARNING



Allow engine to **cool** when flushing out radiator. Flushing the radiator while hot could cause serious burns from water or steam.

RADIATOR CLEANING

The radiator (Figure 58) should be sprayed (cleaned) with a high pressure washer when excessive amounts of dirt and debris have accumulated on the cooling fins or tube. When using a high pressure washer, stand at least 5 feet (1.5 meters) away from the radiator to prevent damage to the fins and tube.

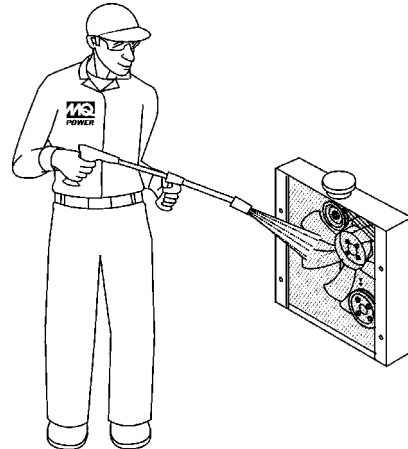

Figure 58. Radiator Cleaning

GENERATOR STORAGE

For long term storage of the generator the following is recommended:

- Drain the fuel tank completely. Treat with a fuel stabilizer if necessary.
- Completely drain the oil from the crankcase and refill if necessary with fresh oil.
- Clean the entire generator, internal and external.
- Cover the generating set and store in a clean, dry place.
- Disconnect the battery.
- Make sure engine coolant is at proper level.
- If generator is mounted on a trailer, jack trailer up and place on blocks so tires do not touch the ground or block and completely remove the tires.

JACKET WATER HEATER AND INTERNAL BATTERY CHARGER 120 VAC INPUT RECEPTACLES (OPTIONAL)

This generator can be optionally equipped with two 120 VAC, 20 amp input receptacles located on the output terminal panel.

The purpose of these receptacles is to provide power via commercial power to the **jacket water heater** and **internal battery charger**.

These receptacles will **ONLY** function when commercial power has been supplied to them (Figure 59). To apply commercial power to these receptacles, a power cord of adequate size will be required (See Table 6).

When using the generator in **hot** climates there is no reason to apply power to jacket water heater. However, if the generator will be used in **cold** climates it is always a good idea to apply power to the jacket water heater at all times. To apply power to the jacket water heater simply apply power to the jacket water heater receptacle via commercial power using an power cord of adequate size.

If the generator will be used daily, the battery should normally not require charging. If the generator will be idle (not used) for long periods of time, apply power to the battery charger receptacle via commercial power using a power cord of adequate size.

NOTICE

To ensure adequate starting capability, always have power applied to the generator's internal battery charger..

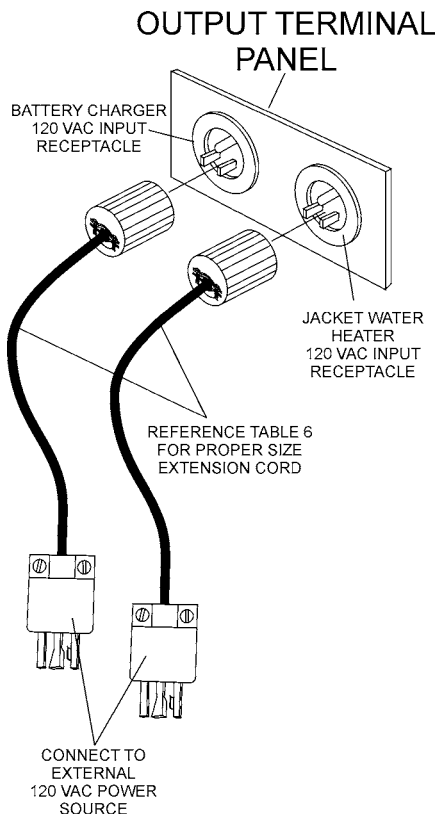

Figure 59. Battery Charger and Jacket Water Heater Power Connections

TRAILER MAINTENANCE

TRAILER MAINTENANCE

This section is intended to provide the user with generic trailer service and maintenance information. The service and maintenance guidelines referenced in this section refer to a wide range of trailers.

Remember periodic inspection of the trailer will ensure safe towing of the generator and will prevent personal injury and damage to the equipment.

The definitions below describe some of the major components of a typical trailer that would be used with the generator.

1. **Fuel Cell** — Provides an adequate amount of fuel for the equipment in use. Fuel cells must be empty when transporting equipment.
2. **Braking System** — System employed in stopping the trailer. Typical braking systems are electric, surge, hydraulic, hydraulic-surge and air.
3. **GVWR** — Gross Vehicle Weight Rating (GVWR) is the maximum number of pounds the trailer can carry, including the fuel cell (empty).
4. **Frame Length** — Measurement is from the ball hitch to the rear bumper (reflector).
5. **Frame Width** — Measurement is from fender to fender
6. **Jack Stand** — Trailer support device with maximum pound requirement from the tongue of the trailer.
7. **Coupler** — Type of hitch used on the trailer for towing.
8. **Tire Size** — Indicates the diameter of the tire in inches (10,12,14, etc.), and the width in millimeters (175,185,205, etc.). The tire diameter must match the diameter of the tire rim.
9. **Tire Ply** — The tire ply (layers) number is rated in letters; 2-ply,4-ply,6-ply, etc.
10. **Wheel Hub** — The wheel hub is connected to the trailer's axle.
11. **Tire Rim** — Tires mounted on a tire rim. The tire rim must match the size of the tire.
12. **Lug Nuts** — Used to secure the wheel to the wheel hub. Always use a torque wrench to tighten down the lug nuts. See Table 16 and Figure 62 for lug nut tightening and sequence.
13. **Axle** — Indicates the maximum weight the axle can support in pounds, and the diameter of the axle expressed in inches. Please note that some trailers have a double axle. This will be shown as 2-6000 lbs., meaning two axles with a total weight capacity of 6000 pounds.
14. **Suspension** — Protects the trailer chassis from shocks transmitted through the wheels. Types of suspension used are leaf, Q-flex, and air ride.
15. **Electrical** — Electrical connectors (looms) are provided with the trailer so the brake lights and turn signals can be connected to the towing vehicle.
16. **Application** — Indicates which units can be employed on a particular trailer.

BRAKES

Trailer brakes should be inspected the **first 200 miles** of operation. This will allow the brake shoes and drums to seat properly. After the first 200 mile interval, inspect the brakes **every 3,000 miles**. If driving over rough terrain, inspect the brakes more frequently.

Figure 60 displays the major hydraulic surge brake components that will require inspection and maintenance. Please inspect these components as required using steps 1 through 8 and Table 13 as listed below:

Brake Adjustment

1. Place the trailer on jack stands. Make sure the jack stands are placed on secure level ground.
2. Check the wheel and drum for free rotation.
3. Remove the adjusting hole cover from the adjusting slot at the bottom brake backing plate.
4. With a screwdriver or standard adjusting tool, rotate the star wheel of the adjuster assembly to expand the brake shoes.
5. Adjust the brake shoes outward until the pressure of the lining against the wheel drum makes the wheel difficult to turn.
6. Adjust, rotate the star wheel in the opposite direction until the wheel rotates freely with slight lining drag.
7. Replace the adjusting hole cover and lower the trailer to the ground.
8. Repeat steps 1 through 7 on the remaining brakes.

Hydraulic Surge Brakes

Hydraulic surge brakes (Figure 60) should not require any special attention with the exception of routine maintenance such as shoe and lining replacement. Brake lines should be periodically checked for cracks, kinks, or blockage.

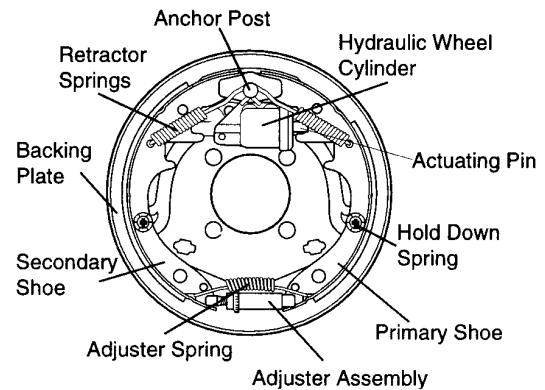

Figure 60. Hydraulic Brake Components

Actuator

Hydraulic surge braking requires the installation of an actuator at the tongue of the trailer. Remember the **surge or push** of the trailer toward the tow vehicle automatically synchronizes the trailer brakes with the tow vehicle brakes. As the trailer pushes against the tow vehicle the actuator telescopes together and applies force to the master cylinder, supplying hydraulic pressure to the trailer brakes.

Periodically check and test the surge “actuator” to make sure that it is functioning correctly. Never use an undersize actuator.

Table 13. Hydraulic Brake Troubleshooting

Symptom	Possible Cause	Solution
No Brakes	Brake line broken or kinked?	Repair or replace.
Weak Brakes or Brakes Pull to One Side	Brake lining glazed?	Reburnish or replace.
	Trailer overloaded?	Correct weight.
	Brake drums scored or grooved?	Machine or replace.
	Tire pressure correct?	Inflate all tires equally.
	Tires unmatched on the same axle?	Match tires.
Locking Brakes	Brake components loose, bent or broken?	Replace components.
	Brake drums out-of-round?	Replace.
Noisy Brakes	System lubricated?	Lubricate.
	Brake components correct?	Replace and correct.
Dragging Brakes	Brake lining thickness incorrect or not adjusted correctly?	Install new shoes and linings.
	Enough brake fluid or correct fluid?	Replace rubber parts fill with dot 4 fluid.

TRAILER MAINTENANCE

TIRES/WHEELS/LUG NUTS

Tires and wheels are a very important and critical components of the trailer. When specifying or replacing the trailer wheels it is important the wheels, tires, and axle are properly matched.

CAUTION



ALWAYS wear safety glasses when removing or installing force fitted parts. Failure to comply may result in serious injury.

CAUTION









DO NOT attempt to repair or modify a wheel. **DO NOT** install in inner tube to correct a leak through the rim. If the rim is cracked, the air pressure in the inner tube may cause pieces of the rim to explode (break off) with great force and cause serious eye or bodily injury.

Tire Wear/Inflation

Tire inflation pressure is the most important factor in tire life. Pressure should be checked cold before operation **DO NOT** bleed air from tires when they are **hot!**. Check inflation pressure weekly during use to insure the maximum tire life and tread wear.

Table 14 (Tire Wear Troubleshooting) will help pinpoint the causes and solutions of tire wear problems.

Table 14. Tire Wear Troubleshooting			
Wear Pattern	Cause	Solution	
	Center Wear	Over inflation.	Adjust pressure to particular load per tire manufacturer.
	Edge Wear	Under inflation.	Adjust pressure to particular load per tire manufacturer.
	Side Wear	Loss of camber or overloading.	Make sure load does not exceed axle rating. Align wheels.
	Toe Wear	Incorrect toe-in.	Align wheels.
	Cupping	Out-of-balance.	Check bearing adjustment and balance tires.
	Flat Spots	Wheel lockup and tire skidding.	Avoid sudden stops when possible and adjust brakes.

Suspension

The **leaf suspension** springs and associated components (Figure 61) should be visually inspected every 6,000 miles for signs of excessive wear, elongation of bolt holes, and loosening of fasteners. Replace all damaged parts (suspension) immediately. Torqued suspension components as detailed in Table 15.

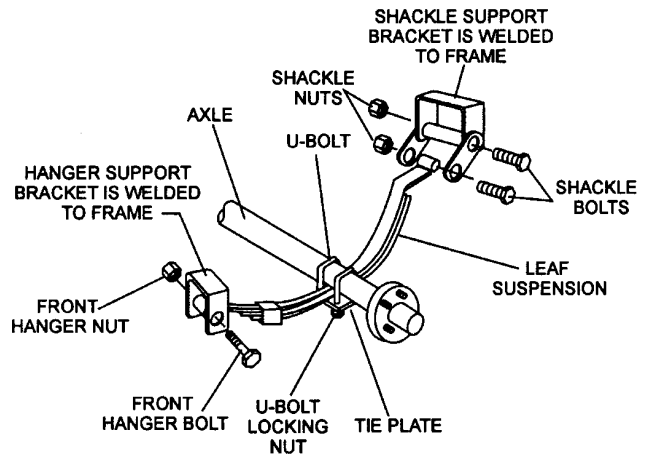

Figure 61. Major Suspension Components

Table 15. Suspension Torque Requirements	
Item	Torque (Ft.-Lbs.)
3/8" U-Bolt	Min-30 Max-35
7/16" U-Bolt	Min-45 Max-60
1/2" U-Bolt	Min-45 Max-60
Shackle Bolt Spring Eye Bolt	Snug fit only. Parts must rotate freely. Locking nuts or cotter pins are provided to retain nut-bolt assembly.
Shoulder Type Shackle Bolt	Min-30 Max-50

TRAILER MAINTENANCE

Lug Nut Torque Requirements

It is extremely important to apply and maintain proper wheel mounting torque on the trailer. Be sure to use only the fasteners matched to the cone angle of the wheel. Proper procedure for attachment of the wheels is as follows:

1. Start all wheel lug nuts by hand.
2. Torque all lug nuts in sequence (see Figure 62). **DO NOT** torque the wheel lug nuts all the way down. Tighten each lug nut in 3 separate passes as defined by Table 16.
3. After first road use, retorque all lug nuts in sequence. Check all wheel lug nuts periodically.

Table 16. Tire Torque Requirements			
Wheel Size	First Pass FT-LBS	Second Pass FT-LBS	Third Pass FT-LBS
12"	20-25	35-40	50-65
13"	20-25	35-40	50-65
14"	20-25	50-60	90-120
15"	20-25	50-60	90-120
16"	20-25	50-60	90-120

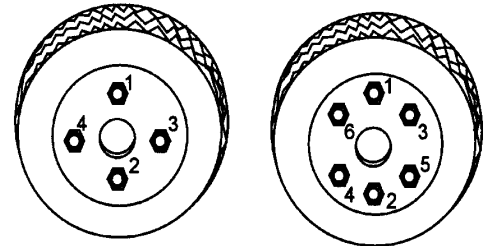

4-LUG NUTS

6-LUG NUTS

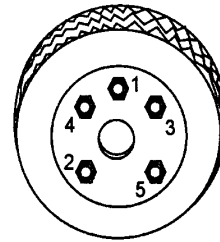

5-LUG NUTS

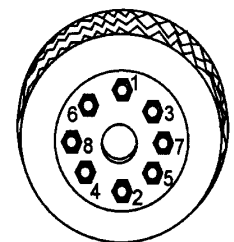

8-LUG NUTS

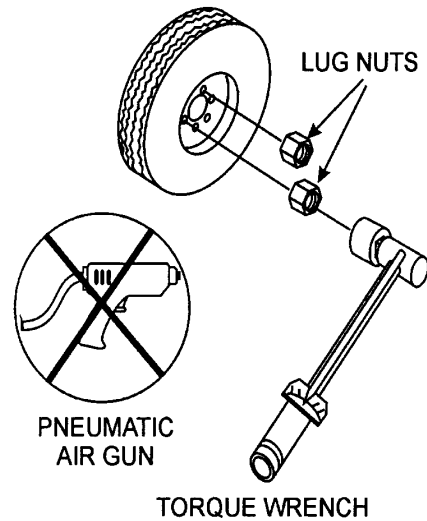

Figure 62. Wheel Lug Nuts Tightening Sequence

NOTICE

NEVER use an pneumatic air gun to tighten wheel lug nuts.

TRAILER WIRING DIAGRAM

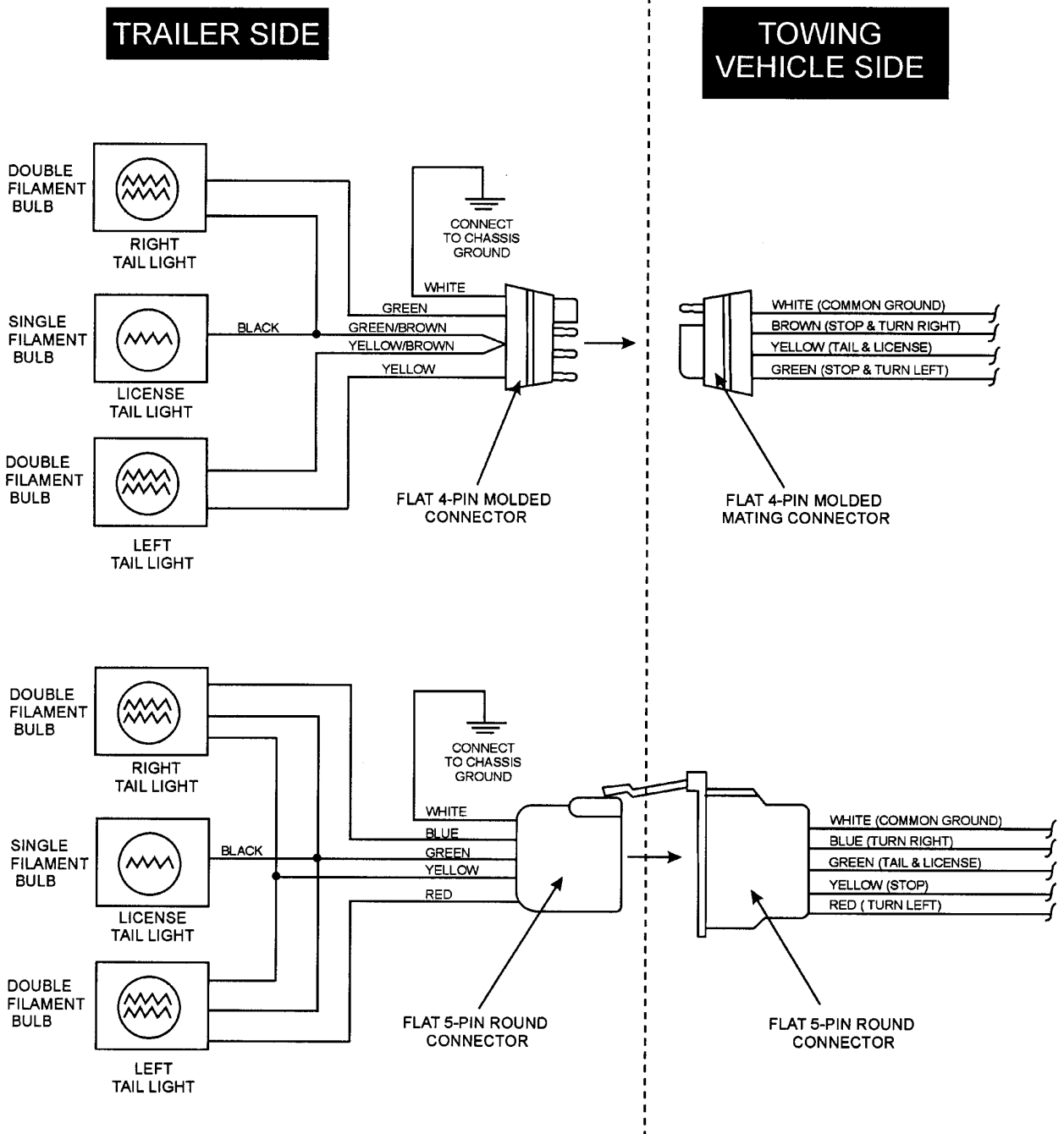

Figure 63. Trailer/Towing Vehicle Wiring Diagram

GENERATOR WIRING DIAGRAM

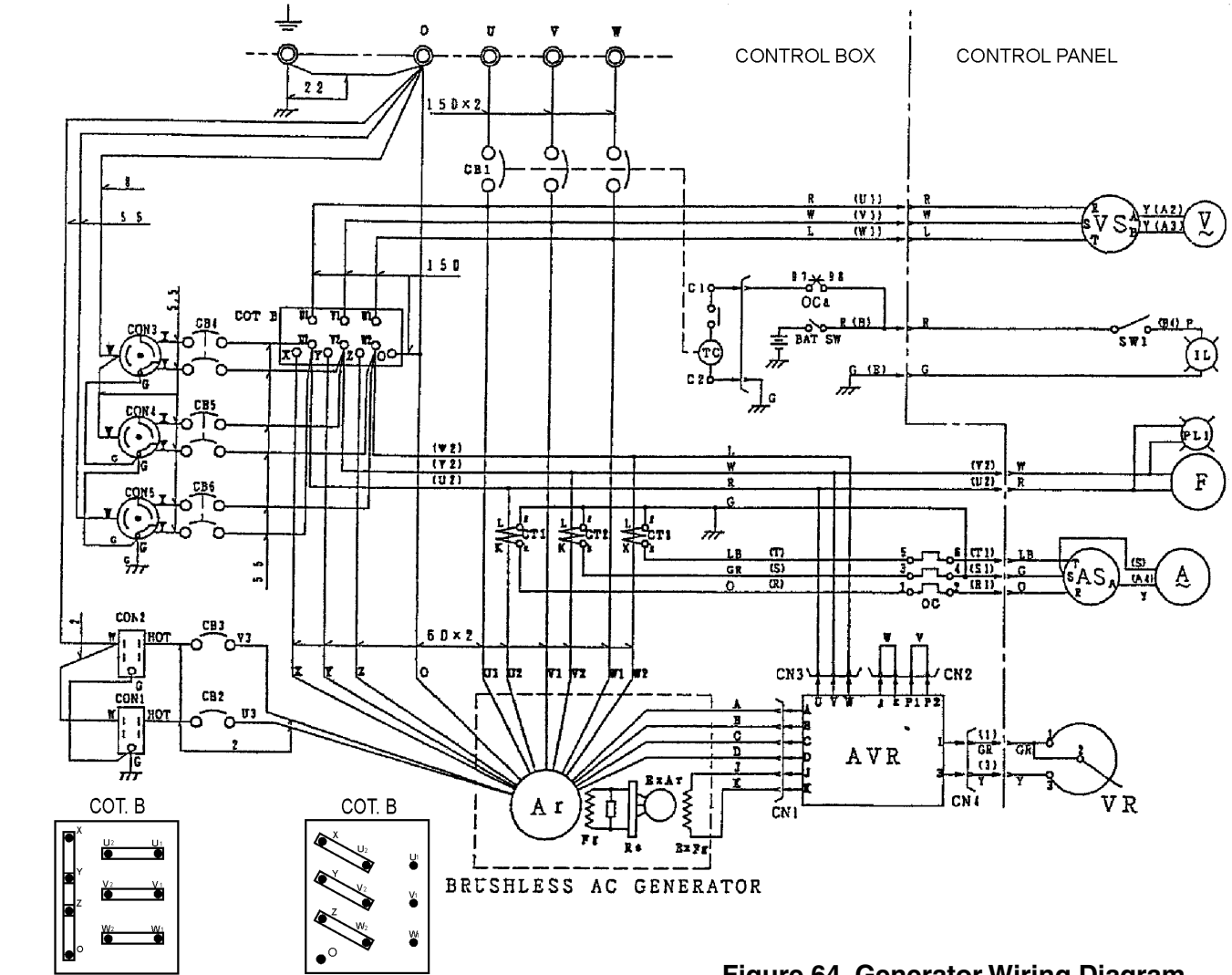
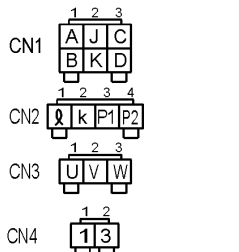

Figure 64. Generator Wiring Diagram

Voltage Change-Over Board-240V Set

Voltage Change-Over Board-480V Set



AVR CONNECTOR (VIEW FROM INSERTING WIRE SIDE)

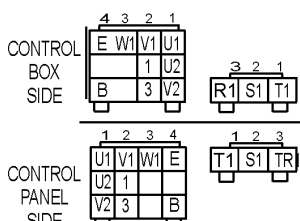

CONNECTOR (VIEW FROM INSERTING WIRE SIDE)

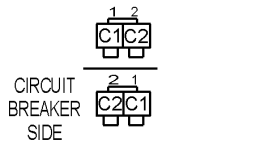

CB1 CONNECTOR (VIEW FROM INSERTING WIRE SIDE)

COLOR CODE		
WIRE COLOR	WIRE COLOR	WIRE COLOR
B BLACK	R RED	
L BLUE	W WHITE	
BR BROWN	Y YELLOW	
G GREEN	LB LIGHT BLUE	
GR GRAY	LG LIGHT GREEN	
V VIOLET	O ORANGE	
P PINK		

SYMBOL	DESIGNATION	SYMBOL	DESIGNATION
Ar	ARMATURE WINDING	A	AC AMMETER 0-750, 1,500A
Fg	MAIN GENERATOR FIELD WINDING	VS	VOLTMETER CHANGE-OVER SWITCH
Ex Ar	EXCITER ARMATURE WINDING	V	AC VOLTMETER 0-600V
Ex Fg	EXCITER FIELD WINDING	F	FREQUENCY METER 45-65 Hz
AVR	AUTOMATIC VOLTAGE REGULATOR	PL1	PILOT LAMP
VR	VOLTAGE REGULATING RHEOSTAT	CB2-3	AUX. CIRCUIT BREAKER 20A
Re	RECTIFIER	CB4-6	AUX. CIRCUIT BREAKER 50A
CT1-3	CURRENT TRANSFORMER 750/5A	CON2-3	RECEPTACLE 520R GFCI 20A, 125V
CB1	CIRCUIT BREAKER 800 AMPS	CON3-5	RECEPTACLE CS-6369 50A, 120/240V
OC	OVER CURRENT RELAY	IL	PANEL LIGHT
COT. B	VOLTAGE CHANGE-OVER BOARD	SW1	PANEL LIGHT SWITCH
AS	AMMETER CHANGE-OVER SWITCH		

ENGINE WIRING DIAGRAM

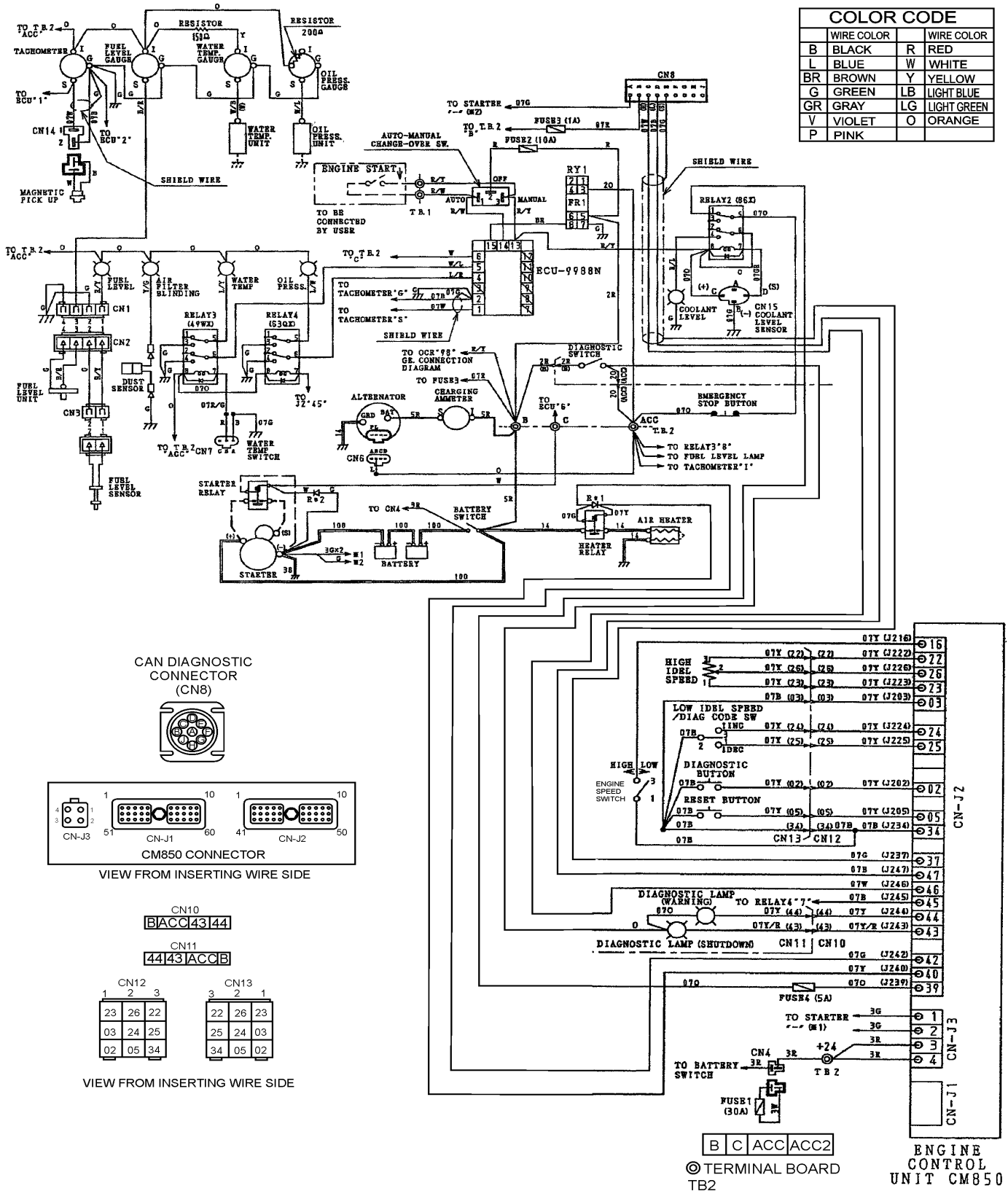

Figure 65. Engine Wiring Diagram

TROUBLESHOOTING (GENERATOR)

Practically all breakdowns can be prevented by proper handling and maintenance inspections, but in the event of a breakdown, use Table 17 shown below for diagnosis of the Generator. If the problem cannot be remedied, consult our company's business office or service plant.

Table 17. Generator Troubleshooting		
Symptom	Possible Problem	Solution
No Voltage Output	AC Voltmeter defective?	Check output voltage using a voltmeter.
	Is wiring connection loose?	Check wiring and repair.
	Is AVR defective?	Replace if necessary.
	Defective Rotating Rectifier?	Check and replace.
	Defective Exciter Field?	Check for approximately 19 ohms across J & K on CN1
Low Voltage Output	Is engine speed correct?	Turn engine throttle lever to "High".
	Is wiring connections loose?	Check wiring and repair.
	Defective AVR?	Replace if necessary.
High Voltage Output	Is wiring connections loose?	Check wiring and repair.
	Defective AVR?	Replace if necessary.
Circuit Breaker Tripped	Short Circuit in load?	Check load and repair.
	Over current?	Confirm load requirements and reduce.
	Defective circuit breaker?	Check and replace.
	Over current Relay actuated?	Confirm load requirement and replace.

TROUBLESHOOTING (ENGINE CONTROLLER)

Practically all breakdowns can be prevented by proper handling and maintenance inspections, but in the event of a breakdown, use Table 18 (Engine Controller Troubleshooting) as a basic guideline for troubleshooting the Microprocessor Engine Controller unit (MPEC). If the problem cannot be remedied, consult our company's business office or service plant.

Table 18. Engine Controller Troubleshooting (MPEC)		
Symptom	Possible Problem	Solution
Low oil pressure light is on.	Low oil level?	Fill oil level.
	Oil pressure sending unit failure?	Replace oil pressure sending unit.
	Time delay malfunction in controller?	Refer to dealer.
	Wire shorted?	Inspect/repair wire.
Low coolant level light is on. (Optionally installed)	Low coolant level?	Fill coolant level.
	Sending unit failure?	Replace sending unit.
	Low battery voltage?	Replace/charge battery.
High coolant temperature light is on.	Fan belt tension incorrect?	Tighten/replace fan belt.
	Air flow is not circulating through radiator?	Clean/repair radiator grill.
	Doors open?	Close doors.
	Exhaust leaking?	Replace/repair gaskets or faulty part.
	Generator being overloaded?	Check/reduce load.
	Thermostat failure?	Replace thermostat.
	Air intake blocked?	Clean all air intakes.
Overcrank light is on.	Temperature switch failure	Replace temperature switch.
	No or low fuel?	Fill fuel level.
Overspeed light is on.	Controller needs to be calibrated?	Refer to dealer.
	RPM engine speed too high?	Adjust RPM.
	Governor actuator needs to be adjusted?	Adjust governor actuator.
	Governor controller needs to be adjusted?	Adjust governor controller.
Loss of MPU light(s) or on.	Engine controller needs to be calibrated?	Refer to dealer.
	Magnetic pick up out of adjustment?	Adjust magnetic pick up.
	Magnetic pick up dirty?	Clean magnetic pick up.

TROUBLESHOOTING (DIAGNOSTIC LAMP)

The engine controller of this generator diagnoses problems that arise from the engine control system and the engine itself. Press the diagnostic button (Figure 66) on the diagnostic panel to determine if an engine malfunction has occurred.

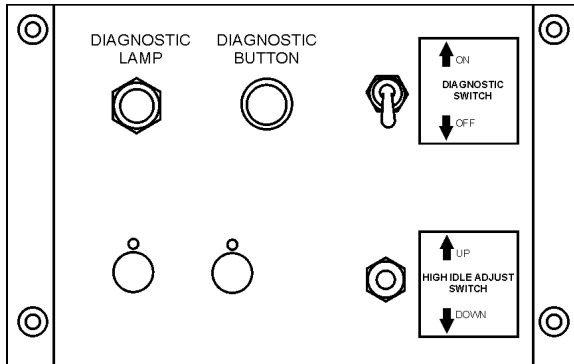

Figure 66. Diagnostic Panel

METHOD OF OPERATION

1. Normally, the diagnostic lamp will be **dimly** lit when the **MPEC Control Switch** is placed in the **MANUAL** position.
2. If engine trouble occurs, the diagnostic lamp will be **brightly** lit as long as the control switch is left in the manual position.
3. The diagnostic lamp will indicate that an engine malfunction has occurred.

NOTICE

For a complete understanding of error codes and troubleshooting procedures, refer to the enclosed engine instruction manual

NOTICE

If the engine is cranked while the diagnostic switch is in the "ON" position, the engine will not be stopped even if the starter switch is turned to the "OFF" position. In such case, turn the diagnostic switch to the "OFF" position..

EXPLANATION OF CODE IN REMARKS COLUMN

The following section explains the different symbols and remarks used in the Parts section of this manual. Use the help numbers found on the back page of the manual if there are any questions.

NOTICE

The contents and part numbers listed in the parts section are subject to change **without notice**. Multiquip does not guarantee the availability of the parts listed.

SAMPLE PARTS LIST

NO.	PART NO.	PART NAME	QTY.	REMARKS
1	12345	BOLT	1	INCLUDES ITEMS W/%
2%		WASHER, 1/4 IN.		NOT SOLD SEPARATELY
2%	12347	WASHER, 3/8 IN. ...	1	MQ-45T ONLY
3	12348	HOSE	A/R	MAKE LOCALLY
4	12349	BEARING	1	S/N 2345B AND ABOVE

NO. Column

Unique Symbols — All items with same unique symbol

(@, #, +, %, or >) in the number column belong to the same assembly or kit, which is indicated by a note in the “Remarks” column.

Duplicate Item Numbers — Duplicate numbers indicate multiple part numbers, which are in effect for the same general item, such as different size saw blade guards in use or a part that has been updated on newer versions of the same machine.

NOTICE

When ordering a part that has more than one item number listed, check the remarks column for help in determining the proper part to order.

PART NO. Column

Numbers Used — Part numbers can be indicated by a number, a blank entry, or TBD.

TBD (To Be Determined) is generally used to show a part that has not been assigned a formal part number at the time of publication.

A blank entry generally indicates that the item is not sold separately or is not sold by Multiquip. Other entries will be clarified in the “Remarks” Column.

QTY. Column

Numbers Used — Item quantity can be indicated by a number, a blank entry, or A/R.

A/R (As Required) is generally used for hoses or other parts that are sold in bulk and cut to length.

A blank entry generally indicates that the item is not sold separately. Other entries will be clarified in the “Remarks” Column.

REMARKS Column

Some of the most common notes found in the “Remarks” Column are listed below. Other additional notes needed to describe the item can also be shown.

Assembly/Kit — All items on the parts list with the same unique symbol will be included when this item is purchased.

Indicated by:

“INCLUDES ITEMS W/(unique symbol)”

Serial Number Break — Used to list an effective serial number range where a particular part is used.

Indicated by:

“S/N XXXXX AND BELOW”

“S/N XXXX AND ABOVE”

“S/N XXXX TO S/N XXX”

Specific Model Number Use — Indicates that the part is used only with the specific model number or model number variant listed. It can also be used to show a part is NOT used on a specific model or model number variant.

Indicated by:

“XXXXX ONLY”

“NOT USED ON XXXX”

“Make/Obtain Locally” — Indicates that the part can be purchased at any hardware shop or made out of available items. Examples include battery cables, shims, and certain washers and nuts.

“Not Sold Separately” — Indicates that an item cannot be purchased as a separate item and is either part of an assembly/kit that can be purchased, or is not available for sale through Multiquip.

SUGGESTED SPARE PARTS

DCA300SSC/DCA300SSCUWHISPERWATT GENERATOR WITH CUMMINGS QSL9-G3 DIESEL ENGINE

1 TO 3 UNITS

QTY.	P/N	DESCRIPTION
1.....	.0602015120.....	HOSE, RADIATOR UPPER ENGINE
1.....	.0602015121.....	HOSE, RADIATOR UPPER/LOWER
1.....	.0602015122.....	HOSE, RADIATOR LOWER
3.....	.0602015244.....	BELT, FAN
1.....	.4921744.....	SENSOR, OIL PRESSURE
1.....	.0602122272.....	OIL PRESSURE UNIT
1.....	.0602123267.....	WATER TEMPERATURE UNIT (DCA300SSC)
1.....	.0602123261.....	WATER TEMPERATURE UNIT (DCA300SSCU)
1.....	.0602210189.....	WATER TEMP. SWITCH ENGINE
1.....	.0602123290.....	SWITCH, COOLANT LEVEL
6.....	.0810105400.....	FILTER, FUEL TANK (DCA300SSC)
6.....	.0602042588.....	FUEL FILTER CARTRIDGE
6.....	.0602042589.....	CARTRIDGE WATER SEPERATOR
6.....	.0602041224.....	FILTER, OIL CARTRIDGE
6.....	.0602045193.....	FILTER, COOLANT CARTRIDGE
3.....	.0602046638.....	ELEMENT AIR CLEANER OUTER
3.....	.0602046639.....	ELEMENT AIR CLEANER INNER
1.....	.0601808803.....	CIRCUIT BREAKER 1P 20A
1.....	.0601808804.....	CIRCUIT BREAKER 2P 50A
2.....	.LY2DUS24VDC	RELAY

NOTICE

Part number on this Suggested Spare Parts list may supersede/replace the P/N shown in the text pages of this book.

GENERATOR ASSY.

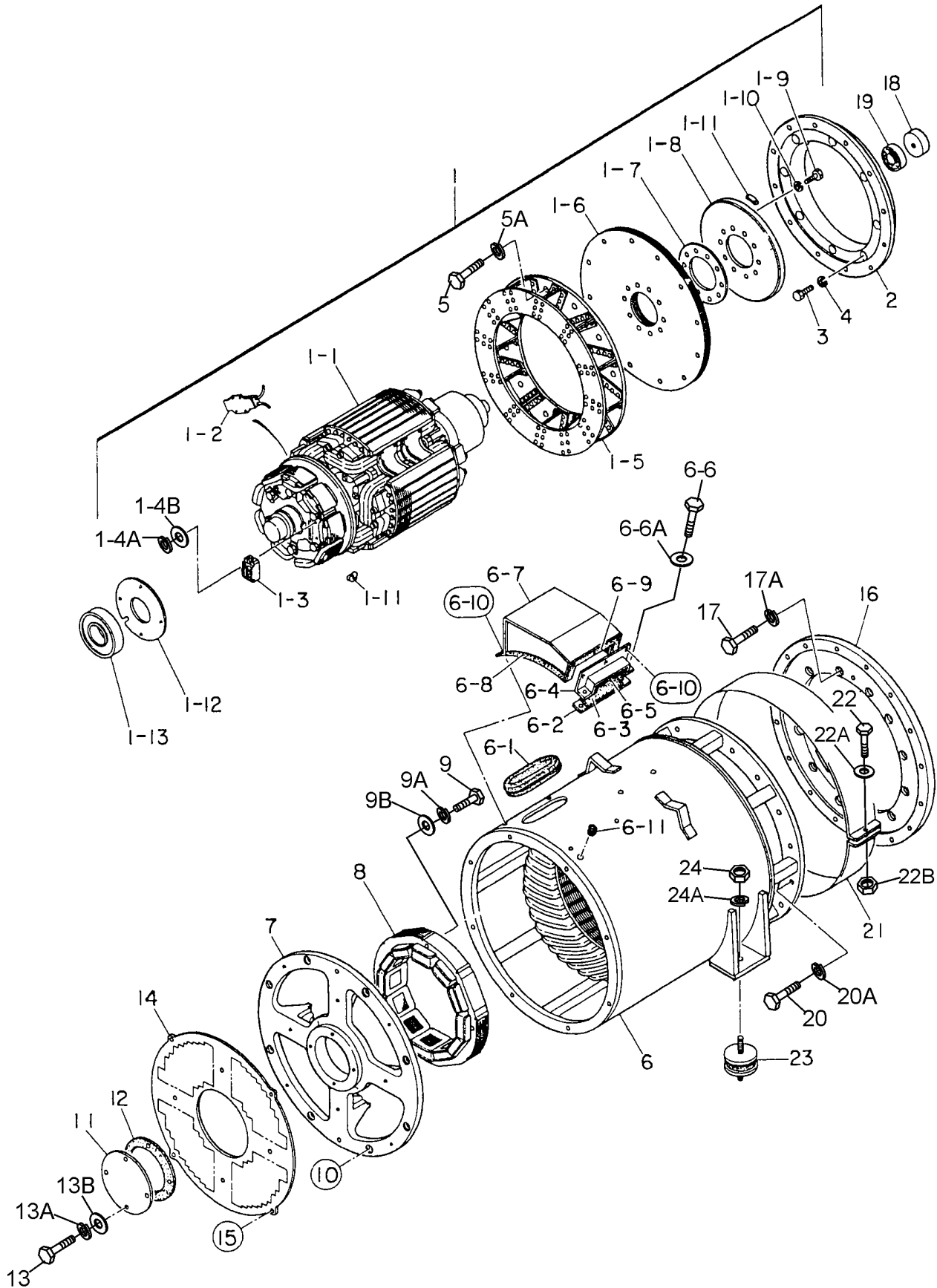

GENERATOR ASSY.

<u>NO.</u>	<u>PART NO.</u>	<u>PART NAME</u>	<u>QTY.</u>	<u>REMARKS</u>
1	C2110000002	ROTOR ASSY	1.....	INCLUDES ITEMS W/#
1-1#		FIELD ASSY	1	
1-2#	0601842402	RESISTOR, 80W 300KΩ	2	
1-3#	0601823282	RECTIFIER	1	
1-4#	0018205020	HEX HD. CAP SCREW	2	
1-4A#	0040005000	WASHER, LOCK	2	
1-4B#	0041205000	WASHER, FLAT	2	
1-5#	8201070002	FAN	1	
1-6#	8201611004	COUPLING DISK	12	
1-7#	C3164200004	WASHER, COUPLING HUB	1	
1-8#	8201015003	BALANCING PLATE.....	1.....	PURCHASE ITEM 1-11 AS A SET
1-9#	0012116045	HEX HEAD BOLT	10	
1-10#	0042616000	WASHER, LOCK	10	
1-11#	0601000209	BALANCING WEIGHT KIT	1	
1-12#	C3112500004	BEARING FLANGE	1	
1-13#	0071906315	BEARING	1	
2	C2163400003	COUPLING RING.....	1.....	DCA300SSC
2	M5163400103	COUPLING RING.....	1.....	DCA300SSCU
3	0343206200	HEX HEAD BOLT	8	
4	0043606000	WASHER, LOCK	8	
5#	0010312040	HEX HEAD BOLT	12	
5A#	0042512000	WASHER, LOCK	12	
6	C2130100103	STATOR ASSY	1	
6-1	0226200430	RUBBER SEAL	1	
6-2	8201323004	CLAMPER	1	
6-3	0223300140	RUBBER SEAL	1	
6-4	8201323103	CLAMPER	1	
6-5	0221200350	RUBBER SEAL	1	
6-6	0010110035	HEX HEAD BOLT	2	
6-6A	0041210000	WASHER, FLAT	2	
6-7	C2132200003	COVER	1	
6-8	0226000275	RUBBER SEAL	2	
6-9	0225000500	RUBBER SEAL	1	
6-10	0017106016	HEX HEAD BOLT	6	
6-11	0601850144	GROMMET	1	
7	C3154000002	END BRACKET	1	
8	C3138000003	FIELD ASSY, EXCITER	1	
9	0012110080	HEX HEAD BOLT	4	
9 A	0042610000	WASHER, LOCK	4	
9 B	0041210000	WASHER, FLAT	4	
10	0017112045	HEX HEAD BOLT	8	
11	C3154300104	COVER, BEARING	1	
12	C3154300004	GASKET, BEARING	1	
13	0010106060	HEX HEAD BOLT	4	
13A	0040006000	WASHER, LOCK	4	
13B	0041206000	WASHER, FLAT	4	

GENERATOR ASSY. (CONTINUED)

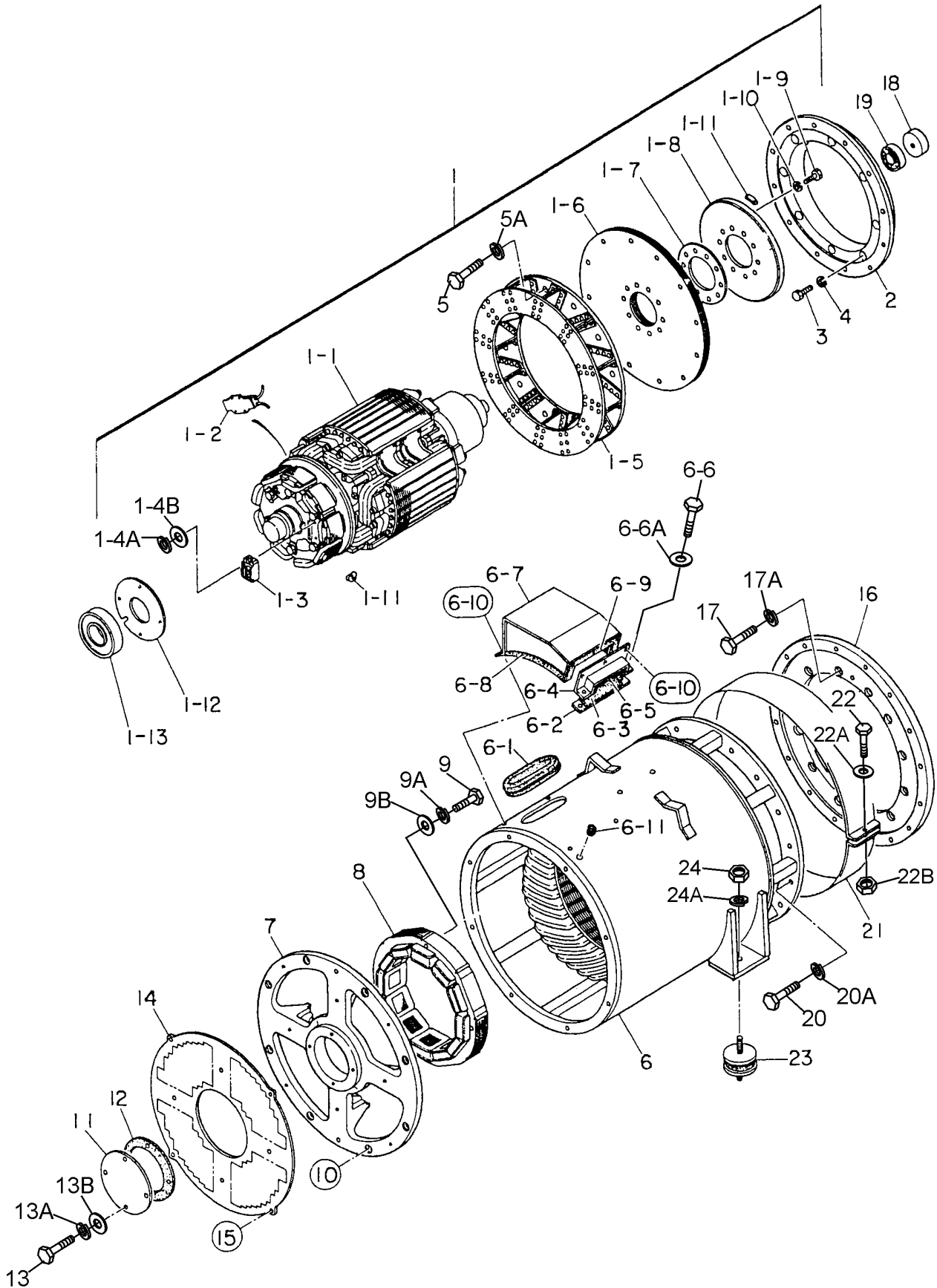

GENERATOR ASSY. (CONTINUED)

<u>NO.</u>	<u>PART NO.</u>	<u>PART NAME</u>	<u>QTY.</u>	<u>REMARKS</u>
14	C3154400003	SUCTION COVER	1	
15	0017106015	HEX HEAD BOLT	8	
16	C3164600103	COUPLING ADAPTER	1	
17	0010310030	HEX HEAD BOLT	12	
17A	0042510000	WASHER, LOCK	12	
18	C2163700004	SPACER, BEARING	1	
19	0070506208	BEARING, 6208ZZ	1	
20	0010312040	HEX HEAD BOLT	16	
20A	0042512000	WASHER, LOCK	16	
21	C3132300014	COVER, FAN	1	
22	0010106030	HEX HEAD BOLT	1	
22A	0041206000	WASHER, FLAT	1	
22B	0600815000	NUT	1	
23	0605000012	RUBBER SUSPENSION	2	
24	0030020000	HEX NUT	4	
24A	0040020000	WASHER, LOCK	4	

CONTROL BOX ASSY.

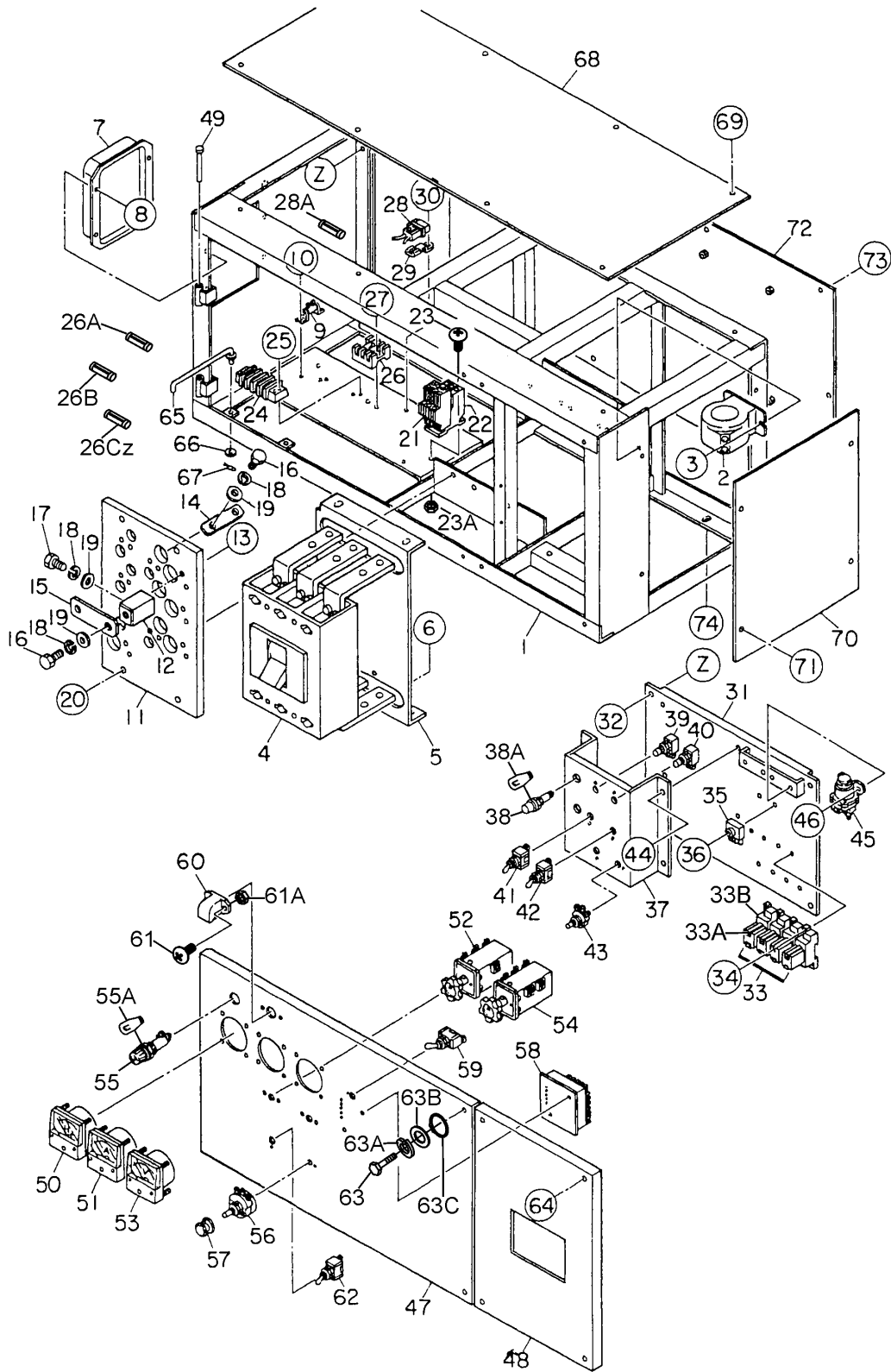

CONTROL BOX ASSY.

<u>NO.</u>	<u>PART NO.</u>	<u>PART NAME</u>	<u>QTY.</u>	<u>REMARKS</u>
1	M5213000002	CONTROL BOX	1	
2	0601809659	CURRENT TRANSFORMER	3	
3	0027106015	MACHINE SCREW	6	
4	0601807513	CIRCUIT BREAKER, 800A	1	DCA300SSC
4	0601807519	CIRCUIT BREAKER, 800A	1	DCA300SSCU
4-1	JGJGJGJGJG	BUS BAR.....		DCA300SSCU
5	C2261600204	BRACKET, CIRCUIT BREAKER	1	
6	0017108020	HEX HEAD BOLT	4	
7	0601820604	AUTOMATIC VOLTAGE REGULATOR	1	
8	0027106015	MACHINE SCREW	4	
9	0601842468	RESISTOR, 5W 150 OHM	1	
10	0027103010	MACHINE SCREW	2	
11	C2274000103	CHANGE- OVER BOARD, VOLTAGE	1	
12	8201852104	CHANGE TERMINAL	10	
13	0017108030	HEX HEAD BOLT	20	
14	C2277200004	TERMINAL PLATE	3	
15	8201853104	CHARGE PLATE	6	
16	8201852504	HEX HEAD BOLT	13	
17	0801830704	HEX HEAD BOLT	13	
18	0040012000	WASHER, LOCK	26	
19	0041412000	WASHER, FLAT	26	
20	0017110030	HEX HEAD BOLT	4	
21	0601820847	OVER CURRENT RELAY	1	
22	0601820840	OVER CURRENT RELAY	1	
23	0027104016	MACHINE SCREW	2	
23A	0207004000	HEX NUT	2	
24	0601815153	TERMINAL BOARD	1	
25	0027104016	MACHINE SCREW	2	
26	0601802218	HOLDER, FUSE	1	
26A	0601802149	FUSE (LEFT SIDE), 10A	1	
26B	0601802131	FUSE (CENTER), 1A	1	
26C	0601802133	FUSE (RIGHT), 5A	1	
27	0027103020	MACHINE SCREW	2	
28	C3358201704	FUSE HOLDER ASSY	1	
28A	0601806644	FUSE, 30A	1	
29	0601802410	BRACKET, FUSE HOLDER	1	
30	0017106016	HEX HEAD BOLT	1	
31	M5260500003	SET PANEL , ELECTRIC PARTS	1	
32	0017108020	HEX HEAD BOLT	4	
33	LY2DUS24V	RELAY	4	REPLACES P/N 0601827655
33A	PTF08A	SOCKET.....	4	REPLACES P/N 0601823109
33B	PYCA1	HOLDER	4	REPLACES P/N 0601824400
34	0027104020	MACHINE SCREW	8	
35	0601823240	RECTIFIER	2	
36	0027104020	MACHINE SCREW	2	
37	M5260500204	BRACKET	1	
38	0602103090	DIAGNOSTIC LAMP	2	
36	0027104020	MACHINE SCREW	2	

CONTROL BOX ASSY. (CONTINUED)

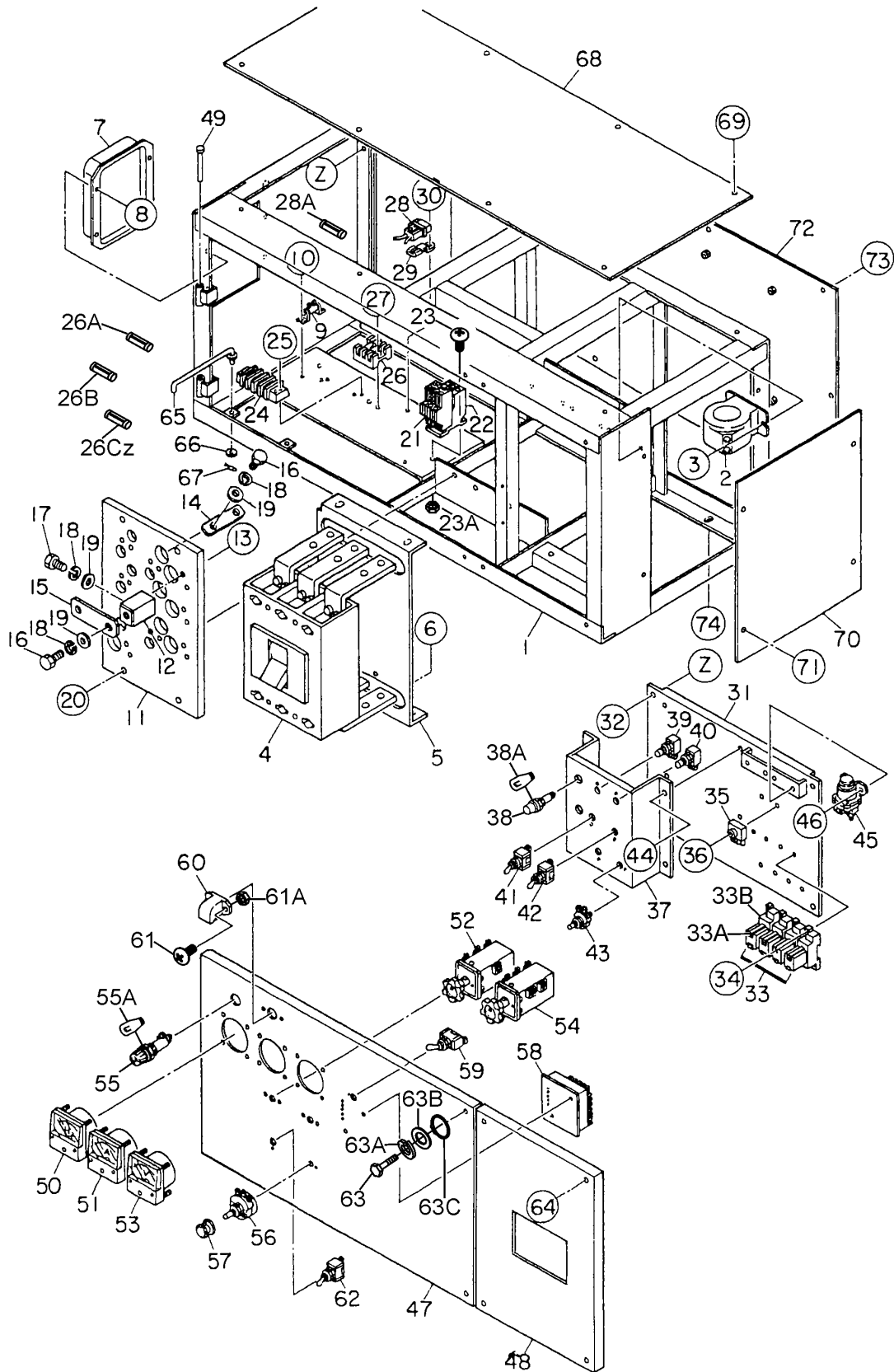

CONTROL BOX ASSY. (CONTINUED)

<u>NO.</u>	<u>PART NO.</u>	<u>PART NAME</u>	<u>QTY.</u>	<u>REMARKS</u>
37	M5260500204	BRACKET	1	
38	0602103090	DIAGNOSTIC LAMP	2	
38A	0601810244	BULB, DC28V	2	
39	0601831670	DIAGNOSTIC BUTTON	1	
40	0601831205	RESET BUTTON	1	
41	0601830746	LOW IDLE SPEED SWITCH	1	
42	0601830710	DIAGNOSTIC SWITCH	1	
43	0601840009	RHEOSTAT, 2W 5k OHM	1	
44	0017106016	HEX HEAD BOLT	4	
45	0602201455	RELAY, HEATER	1	
46	0017106016	HEX HEAD BOLT	2	
47	C2224000503	CONTROL PANEL	1	
48	C2224001504	CONTROL PANEL	1	
49	0605011211	PIN	2	
50	0601807622	FREQUENCY METER, 45~65Hz 220V	1	
51	0601806979	AC AMMETER, 0~1000A	1	
52	0601801040	CHANGE- OVER SWITCH, AMMETER	1	
53	0601806887	AC VOLTMETER, 0~600V	1	
54	0601801041	CHANGE- OVER SWITCH, VOLTMETER	1	
55	0601810072	PILOT LAMP	1	
55A	0601810261	BULB, 13W	1	
56	0601840073	RHEOSTAT (VR), 2W 1K OHM	1	
57	0601840121	KNOB	1	
58	ECU9988N220V	ENGINE CONTROLLER.....	1	REPLACES P/N 0602202545
59	0601830765	SWITCH	1	
60	0601810171	PANEL LIGHT, DC24V	1	
61	0027104020	MACHINE SCREW	2	
61A	0207004000	HEX NUT	2	
62	0601830710	SWITCH, PANEL LIGHT	1	
63	C9221100004	HEX HEAD BOLT	2	
63A	0040008000	WASHER, LOCK	2	
63B	0041208000	WASHER, FLAT	2	
63C	0080200007	SNAP RING	2	
64	0017108040	HEX HEAD BOLT	4	
65	3871824004	STOPPER, CONTROL PANEL	1	
66	0041206000	WASHER, FLAT	1	
67	0605010502	SNAP PIN	1	
68	C2214500004	COVER, CONTROL BOX	1	
69	0017108020	HEX HEAD BOLT	8	
70	C2214300004	SIDE PANEL, CONTROL BOX	1	
71	0017108020	HEX HEAD BOLT	4	
72	C2214400504	PANEL, CONTROL BOX	1	
73	0017108020	HEX HEAD BOLT	9	
74	0017110025	HEX HEAD BOLT	4	

ENGINE AND RADIATOR ASSY.

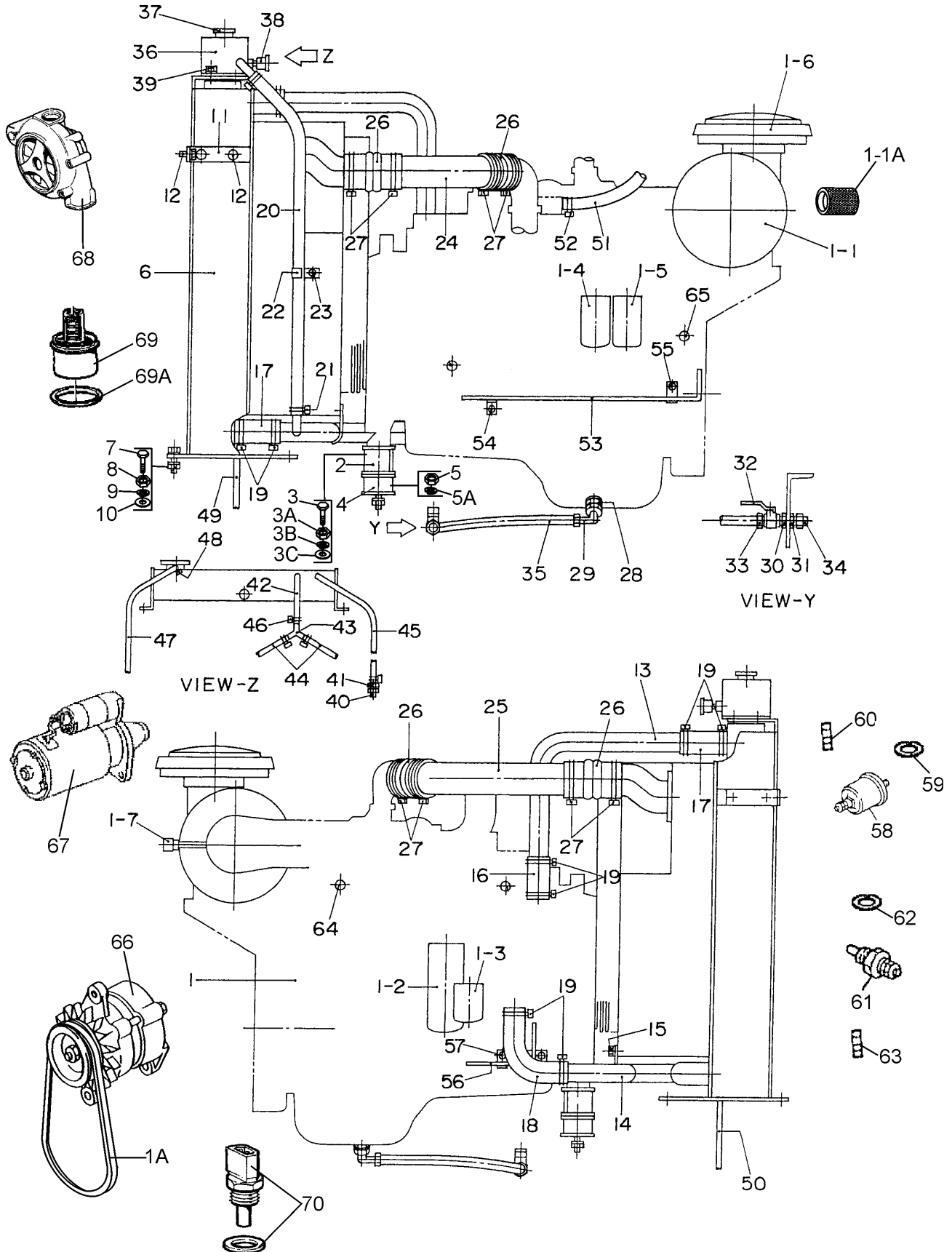

ENGINE AND RADIATOR ASSY.

<u>NO.</u>	<u>PART NO.</u>	<u>PART NAME</u>	<u>QTY.</u>	<u>REMARKS</u>
1	C2923200204	ENGINE, QSL9-G3	1	
1A	0602015244	BELT, FAN	1	
1-1	0602046638	ELEMENT, AIR CLEANER (OUTER)	1	
1-1A	0602046639	ELEMENT, AIR CLEANER (INNER)	1	
1-2	0602041224	CARTRIDGE, OIL FILTER	1	
1-3	0602045193	CARTRIDGE, COOLANT FILTER	1	
1-4	0602042588	CARTRIDGE, FUEL FILTER	1	
1-5	0602042589	CARTRIDGE, FUEL WATER SEPARATOR	1	
1-6	0602040759	CAP, AIR CLEANER	1	
1-7	0602040679	DUST SENSOR	1	
2	M5303200004	ENGINE FOOT	1	
3	0010118050	HEX HEAD BOLT	2	
3A	0030018000	HEX NUT	2	
3B	0040018000	WASHER, LOCK	2	
3C	0041618000	WASHER, FLAT	4	DCA300SSC
3C	0041218000	WASHER, FLAT	4	DCA300SSCU
4	0605000011	RUBBER SUSPENSION	2	
5	0030016000	HEX NUT	4	
5A	0040016000	WASHER, LOCK	4	
6	0602012737	RADIATOR / INTERCOOLER	1	
7	0010116050	HEX HEAD BOLT	4	
8	0030016000	HEX NUT	4	
9	0040016000	WASHER, LOCK	4	
10	0041216000	WASHER, FLAT	8	
11	C2311101104	BRACKET, RADIATOR.....	2	DCA300SSC
11	M5310200204	BRACKET, RADIATOR.....	2	DCA300SSCU
12	0017112025	HEX HEAD BOLT	6	
13	0602013260	RADIATOR PIPE	1	
14	0602014820	RADIATOR PIPE	1	
15	0602011500	HEX HEAD BOLT	2	
16	0602015120	RADIATOR HOSE, UPPER ENGINE	1	
17	0602015121	RADIATOR HOSE, UPPER/LOWER RAD.	2	
18	0602015122	RADIATOR HOSE, LOWER	1	
19	0602015301	HOSE BAND	16	
20	0602015123	RADIATOR HOSE	1	
21	0602015302	HOSE BAND	2	
22	0602015410	CLAMP	1	
23	0602011500	HEX HEAD BOLT	1	
24	0602014821	INTER-COOLER PIPE	1	
25	0602013261	INTER-COOLER PIPE	1	
26	0602015124	INTER-COOLER PIPE	4	
27	0602015303	HOSE BAND	8	
28	0602022563	ADAPTER	1	
29	0602022561	90 DEGREE ELBOW	1	
30	0603306590	CONNECTOR	1	
31	0603300285	LOCKNUT	1	
32	0605511395	VALVE	1	

ENGINE AND RADIATOR ASSY. (CONTINUED)

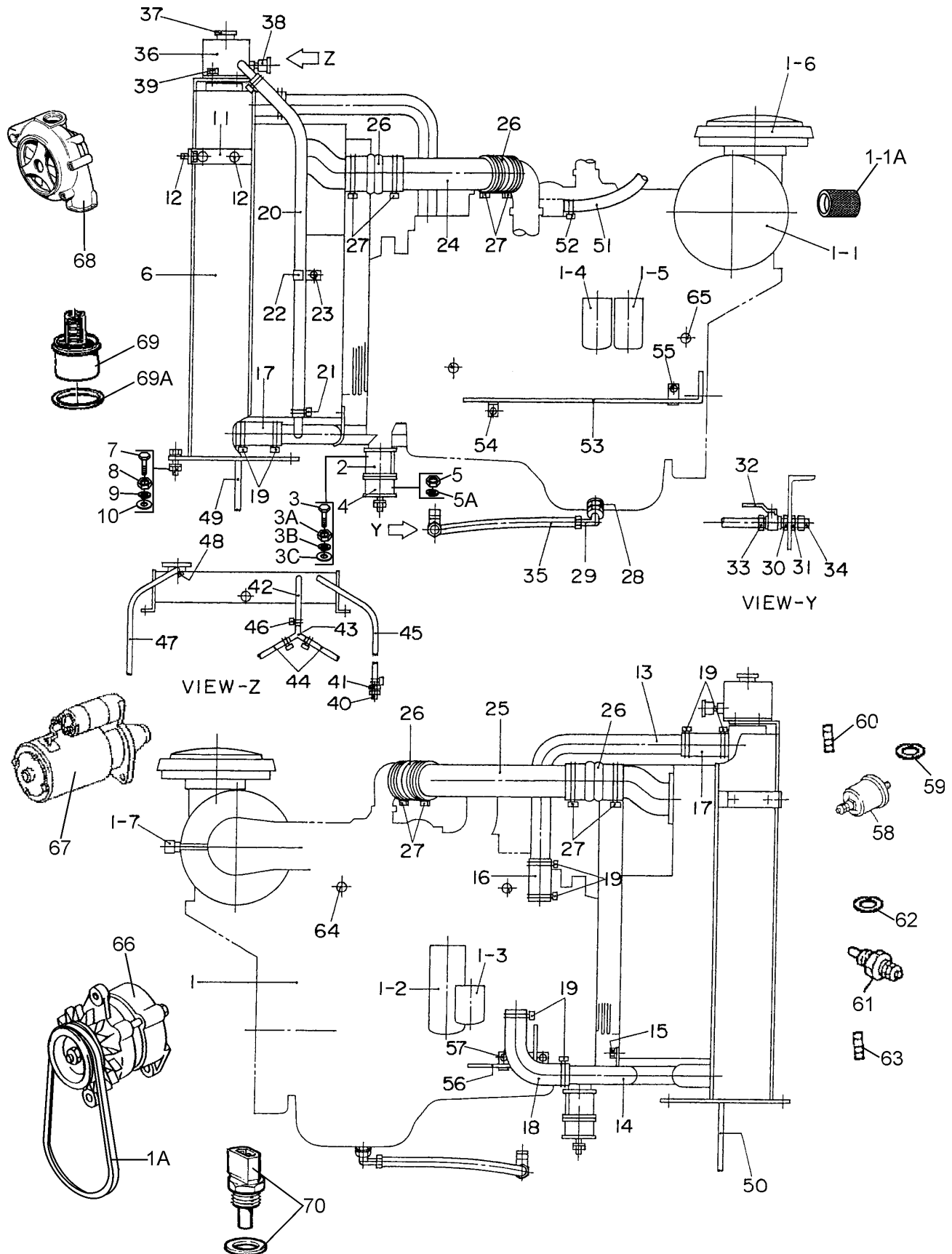

ENGINE AND RADIATOR ASSY. (CONTINUED)

<u>NO.</u>	<u>PART NO.</u>	<u>PART NAME</u>	<u>QTY.</u>	<u>REMARKS</u>
33	0603306395	HOSE JOINT	1	
34	0602021070	CAP	1	
35	0269200800	DRAIN HOSE	1	
36	0602010220	RESERVER TANK	1	
37	0602011023	CAP	1	
38	813NLU0000T	COOLANT LEVEL SWITCH	1	
39	0602011500	HEX HEAD BOLT.....	4	DCA300SSC
39	0016910025	HEX HEAD BOLT.....	4	DCA300SSCU
40	0602015500	BUSHING	1	
41	0602013497	HOSE JOINT	1	
42	0602014110	HOSE (L=250)	1	
43	0602013498	JOINT	1	
44	0602014110	HOSE (L=325)	2	
45	0602014110	HOSE (L=1100)	1	
46	0602015300	HOSE BAND	8	
47	0193601800	HOSE	1	
48	0605515106	HOSE BAND	1	
49	0193601100	HOSE	1	
50	0193600550	HOSE	1	
51	0269501850	HOSE	1	
52	0605515067	HOSE BAND.....	2	DCA300SSC
52	0605515149	HOSE BAND.....	2	DCA300SSCU
53	C2357300003	CLAMPER ROD.....	1	DCA300SSC
53	M5357300003	CLAMPER ROD.....	1	DCA300SSCU
54	0017112025	HEX HEAD BOLT	1	
55	0017116030	HEX HEAD BOLT	1	
56	C2357300104	CLAMPER ROD	1	
57	0017112025	HEX HEAD BOLT	2	
58	0602122272	OIL PRESSURE UNIT	1	
59	M9200101504	ADAPTER	1	
60	0803000104	PACKING	1	DCA300SSC
60	M9200001104	PACKING	1	DCA300SSCU
61	0602123267	WATER TEMPERATURE UNIT.....	1	DCA300SSC
61	0602123261	WATER TEMPERATURE UNIT.....	1	DCA300SSCU
62	0602015501	ADAPTER		
63	9095720140	PACKING	1	REPLACES P/N 0602021109
64	0602210189	WATER TEMPERATURE SWITCH	1	
65	0602120481	PICK- UP TACHOMETER	1	
66	4993343	ALTERNATOR	1	
67	3102763	STARTER	1	
68	3973114	WATER PUMP	1	
69	3940632	THERMOSTAT W/O	1	
69A	3945603	GASKET, THERMOSTAT	1	
70	4921744	SENSOR, OIL PRESSURE	1	

ENGINE OPERATING PANEL ASSY.

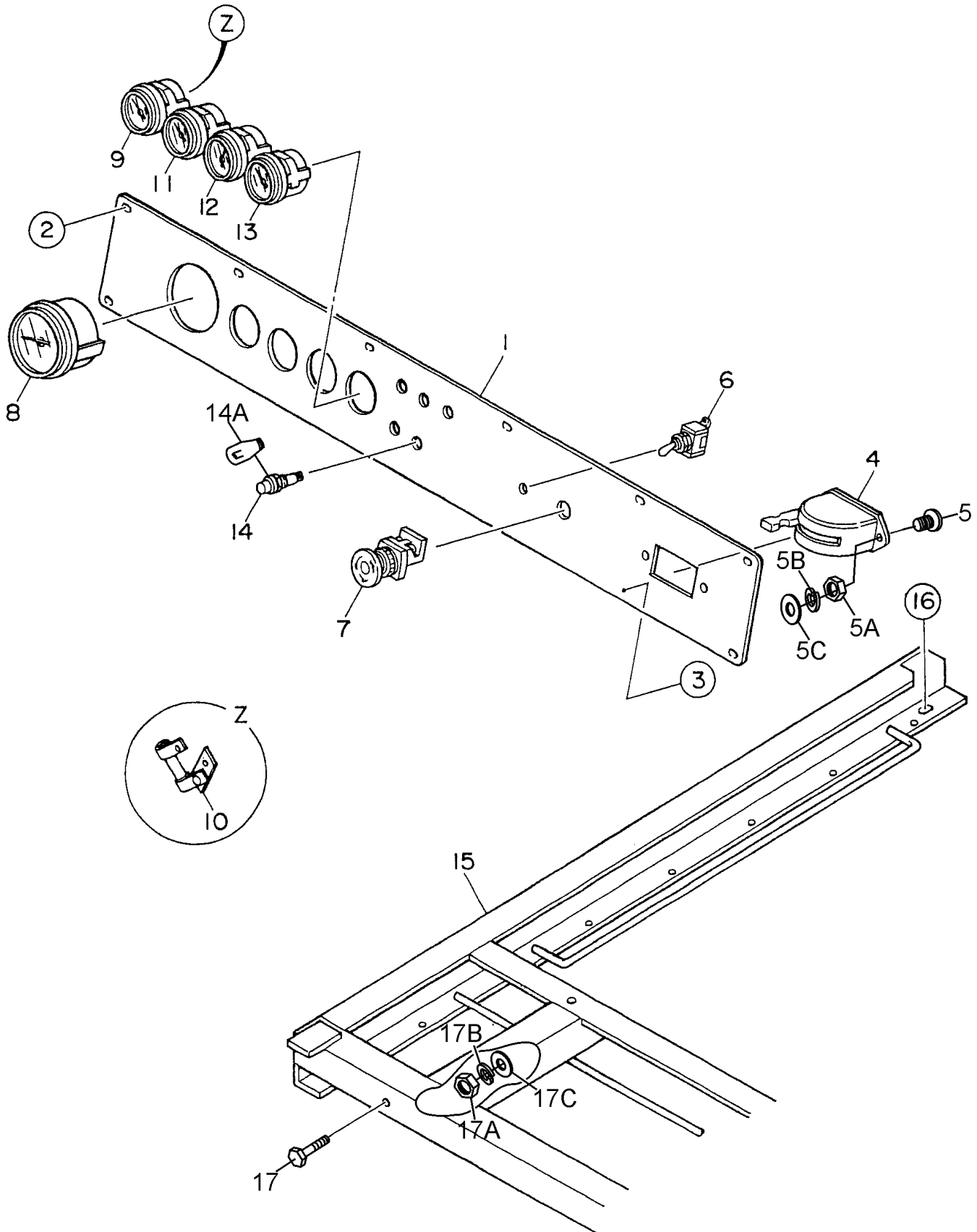

ENGINE OPERATING PANEL ASSY.

<u>NO.</u>	<u>PART NO.</u>	<u>PART NAME</u>	<u>QTY.</u>	<u>REMARKS</u>
1	C2351101903	OPERATING PANEL.....	1	DCA300SSC
1	M5351100003	OPERATING PANEL.....	1	DCA300SSCU
2	0017106020	HEX HEAD BOLT.....	8	DCA300SSC
2	0017106016	HEX HEAD BOLT.....	8	DCA300SSCU
3	0207006000	HEX NUT	4	
4	0602101000	BATTERY SWITCH	1	
5	0021008080	MACHINE SCREW	2	
5A	0030004000	HEX NUT	2	
5B	0040008000	WASHER, LOCK	2	
5C	0041608000	WASHER, FLAT	2	
6	0601830710	ENGINE SPEED SWITCH	1	
7	0601831557	EMERGENCY STOP BUTTON	1	
8	0602120095	TACHOMETER	1	
9	0602122093	OIL PRESSURE GAUGE	1	
10	0601842450	VOLTAGE DIVIDER	1	
11	0602123092	WATER TEMPERATURE GAUGE	1	
12	0602121081	CHARGING AMMETER	1	
13	0602125091	FUEL GAUGE	1	
14	0602103090	ALARM LAMP	5	
14A	0601810244	BULB, DC28V	5	
15	M5483000003	SET FRAME	1	
16	0017110030	HEX HEAD BOLT.....	2	DCA300SSC
16	0016910030	HEX HEAD BOLT.....	2	DCA300SSCU
17	0017110030	HEX HEAD BOLT	3	
17A	0030010000	HEX NUT	3	
17B	0040010000	WASHER, LOCK	3	
17C	0041610000	WASHER, FLAT	6	

OUTPUT TERMINAL ASSY.

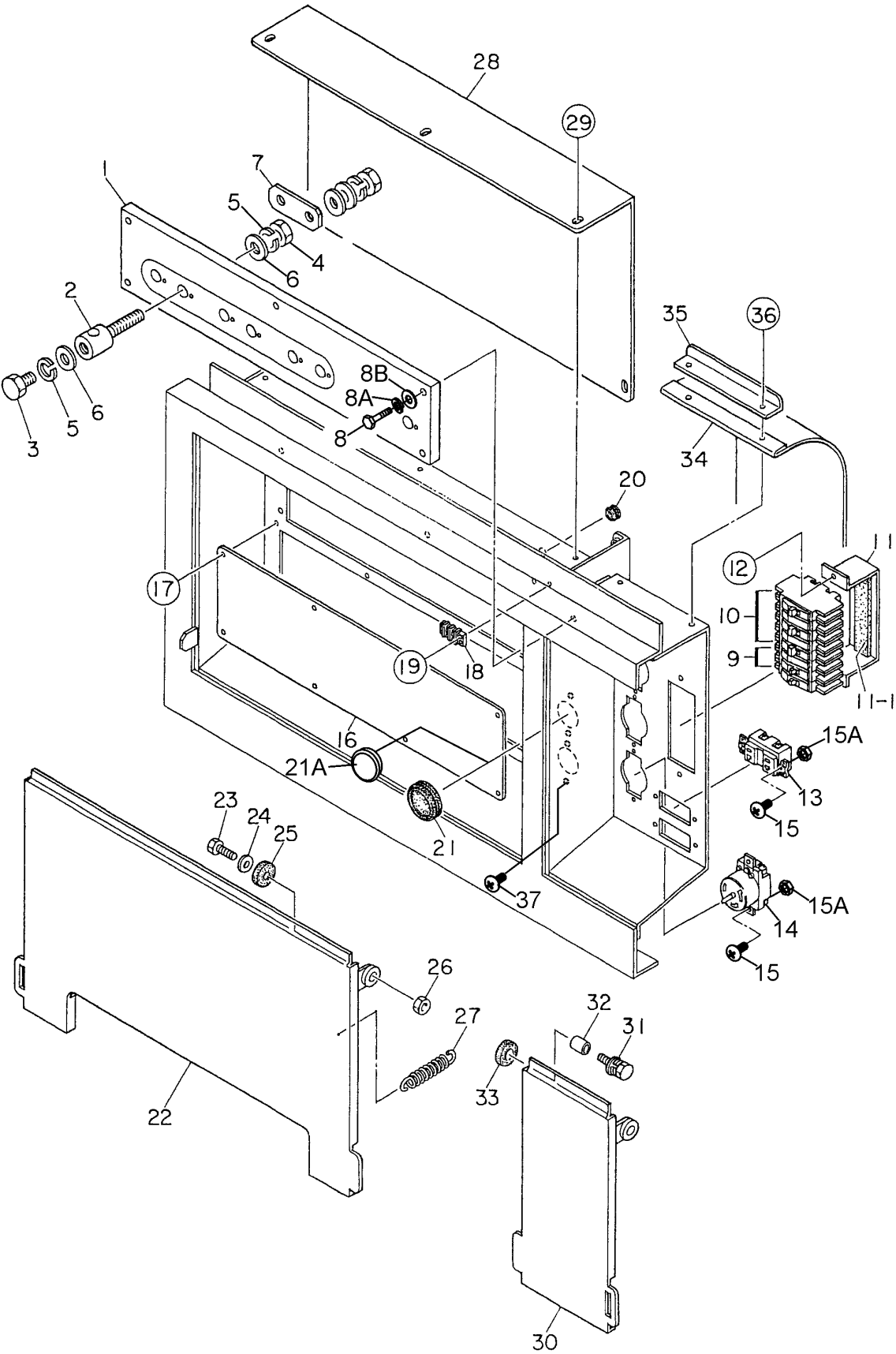

OUTPUT TERMINAL ASSY.

<u>NO.</u>	<u>PART NO.</u>	<u>PART NAME</u>	<u>QTY.</u>	<u>REMARKS</u>
1	C2231700403	SET BOARD, OUTPUT TERMINAL	1	DCA300SSC
1	M5230700003	SET BOARD, OUTPUT TERMINAL	1	DCA300SSCU
2	C0277500004	OUTPUT TERMINAL.....	8	DCA300SSC
2	M9220100914	OUTPUT TERMINAL.....	8	DCA300SSCU
3	0801830904	HEX HEAD BOLT	8	DCA300SSC
3	9220101004	HEX HEAD BOLT	8	DCA300SSCU
4	0039320000	HEX NUT	16	
5	0040020000	WASHER, LOCK	24	
6	0041420000	WASHER, FLAT	32	
7	3501860604	TERMINAL PLATE	3	DCA300SSC
7	M5233200004	TERMINAL PLATE	3	DCA300SSCU
8	0019110050	HEX HEAD BOLT	5	
8A	0042310000	WASHER, LOCK	5	
8B	0042410000	WASHER, FLAT	5	
9	0601808803	CIRCUIT BREAKER, 1P 20A	2	
10	0601808804	CIRCUIT BREAKER, 2P 50A	3	
11	C3261600704	BRACKET, CIRCUIT BREAKER	1	DCA300SSC
11	M4260600104	BRACKET, CIRCUIT BREAKER	1	DCA300SSCU
11-1	0221200150	RUBBER CUSHION	1	
12	0019206020	HEX HEAD BOLT	2	
13	0601814013	RECEPTACLE	2	
14	0601811034	RECEPTACLE, CS6369	3	
15	0025304015	MACHINE SCREW	10	DCA300SSC
15	0025304016	MACHINE SCREW	10	DCA300SSCU
15A	0207004000	HEX NUT	10	
16	C2234500104	COVER.....	1	DCA300SSC
16	M4236400204	COVER.....	1	DCA300SSCU
17	0019206020	HEX HEAD BOLT	8	DCA300SSC
17	0016906016	HEX HEAD BOLT	8	DCA300SSCU
18	0601815194	TERMINAL BOARD	1	
19	0025304015	MACHINE SCREW	2	DCA300SSC
19	7538070	MACHINE SCREW	2	DCA300SSCU
20	0601850275	GROMMET	1	
21	0601851780	GROMMET	2	DCA300SSC
21A	0601851780	BLIND PLUG	1	DCA300SSCU
22	C2237102303	COVER, OUTPUT TERMINAL.....	1	DCA300SSC
22	M5236100003	COVER, OUTPUT TERMINAL.....	1	DCA300SSCU
23	0019112045	HEX HEAD BOLT	2	
24	0042412000	WASHER, FLAT	4	
25	0605015604	STAY RUBBER.....	2	DCA300SSC
25	M9310200004	STAY RUBBER.....	2	DCA300SSCU
26	0205012000	HEX NUT	2	
27	0845043704	SPRING.....	2	DCA300SSC
27	M9210000204	SPRING.....	2	DCA300SSCU
28	C2237101204	COVER.....	1	DCA300SSC
28	M5236100204	COVER.....	1	DCA300SSCU

OUTPUT TERMINAL ASSY.

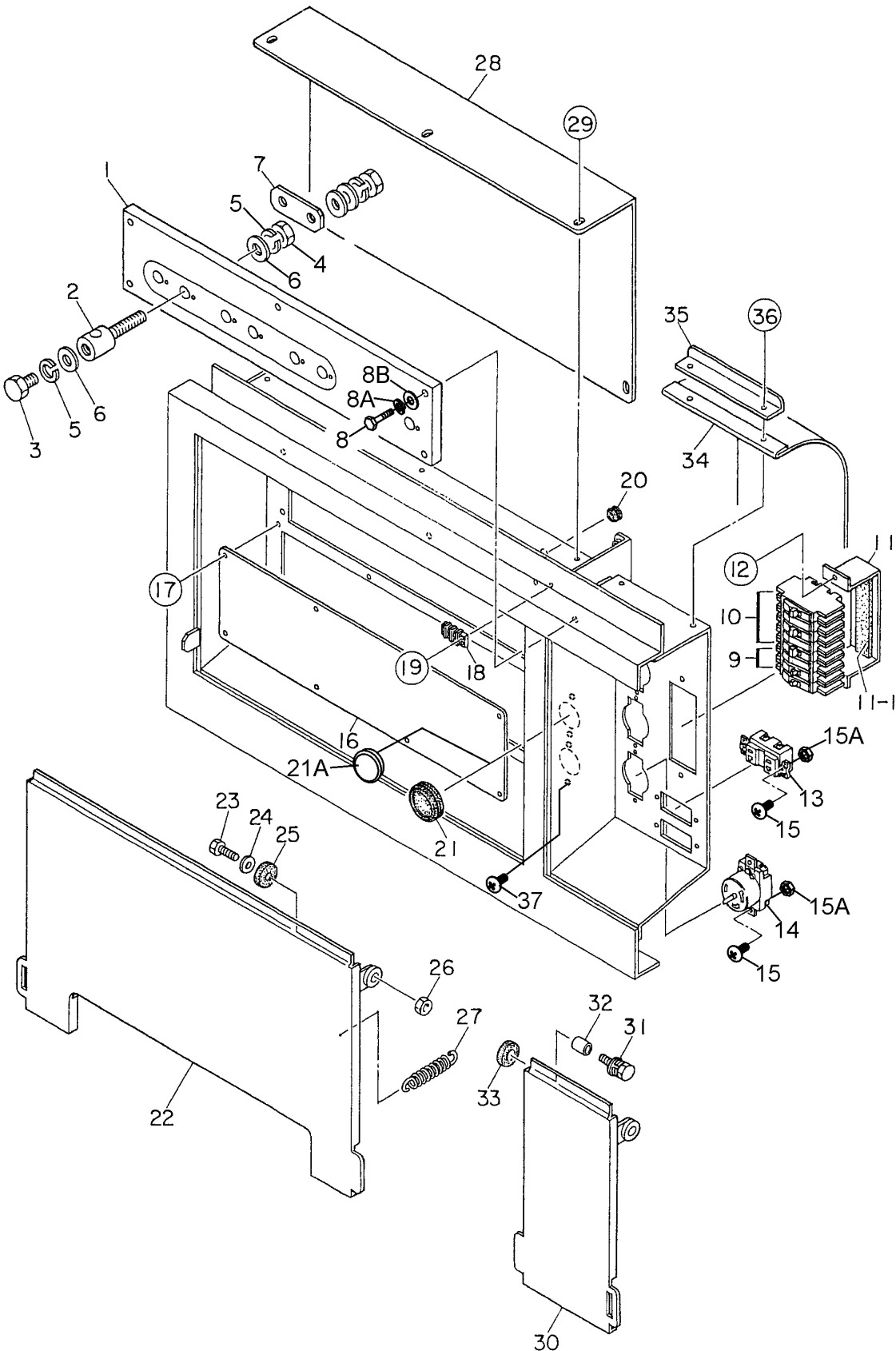

OUTPUT TERMINAL ASSY.

<u>NO.</u>	<u>PART NO.</u>	<u>PART NAME</u>	<u>QTY.</u>	<u>REMARKS</u>
29	0017108020	HEX HEAD BOLT	7	DCA300SSC
29	0016908020	HEX HEAD BOLT	7	DCA300SSCU
30	C2237102403	COVER, OUTPUT TERMINAL.....	1	DCA300SSC
30	M5236100104	COVER, OUTPUT TERMINAL.....	1	DCA300SSCU
31	0019210030	HEX HEAD BOLT	2	DCA300SSC
31	014210040	HEX HEAD BOLT	2	DCA300SSCU
32	0845054204	COLLAR	2	DCA300SSC
32	M9116000004	COLLAR	2	DCA300SSCU
33	0805015604	STAY RUBBER	1	DCA300SSC
33	M9310200004	STAY RUBBER.....	1	DCA300SSCU
34	C2237101504	COVER.....	1	DCA300SSC
34	M4236100604	COVER.....	1	DCA300SSCU
35	C2237500104	BRACKET	1	DCA300SSC
35	M4236400304	BRACKET	1	DCA300SSCU
36	0017106020	HEX HEAD BOLT	2	DCA300SSC
36	0016906016	HEX HEAD BOLT	2	DCA300SSCU
37	7538070	MACHINE SCREW	4	DCA300SSCU

BATTERY ASSY. (DCA300SSC)

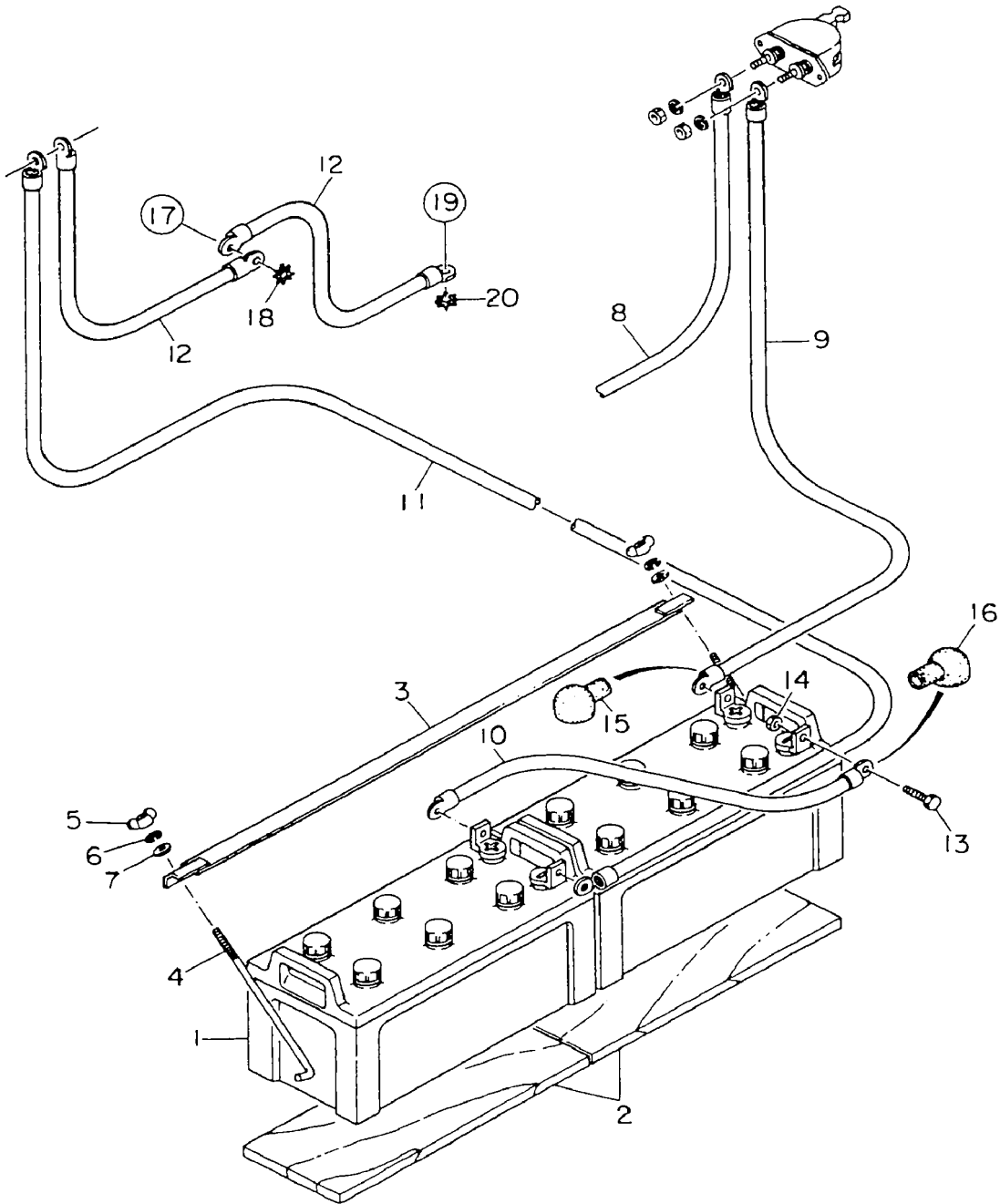

BATTERY ASSY. (DCA300SSC)

<u>NO.</u>	<u>PART NO.</u>	<u>PART NAME</u>	<u>QTY.</u>	<u>REMARKS</u>
1	0165511551	BATTERY	2	
2	C9109100604	BATTERY SHEET	2	
3	3972250004	BATTERY BAND	1	
4	0805002904	BATTERY BOLT	2	
5	0037808000	WING NUT	2	
6	0040008000	WASHER, LOCK	2	
7	0041608000	WASHER, FLAT	2	
8	C2346600404	BATTERY CABLE	1	
9	C2346600304	BATTERY CABLE	1	
10	C2347600704	BATTERY CABLE	1	
11	C2346600504	BATTERY CABLE	1	
12	C2346200004	EARTH CABLE	2	
13	0347010030	HEX HEAD BOLT	4	
14	0208110000	HEX NUT	4	
15	0845040414	TERMINAL CAP (+)	2	
16	0845041304	TERMINAL CAP (-)	2	
17	0017116030	HEX HEAD BOLT	1	
18	0040516000	TOOTHED WASHER	1	
19	0017112025	HEX HEAD BOLT	1	
20	0040512000	TOOTHED WASHER	1	

BATTERY ASSY. (DCA300SSCU)

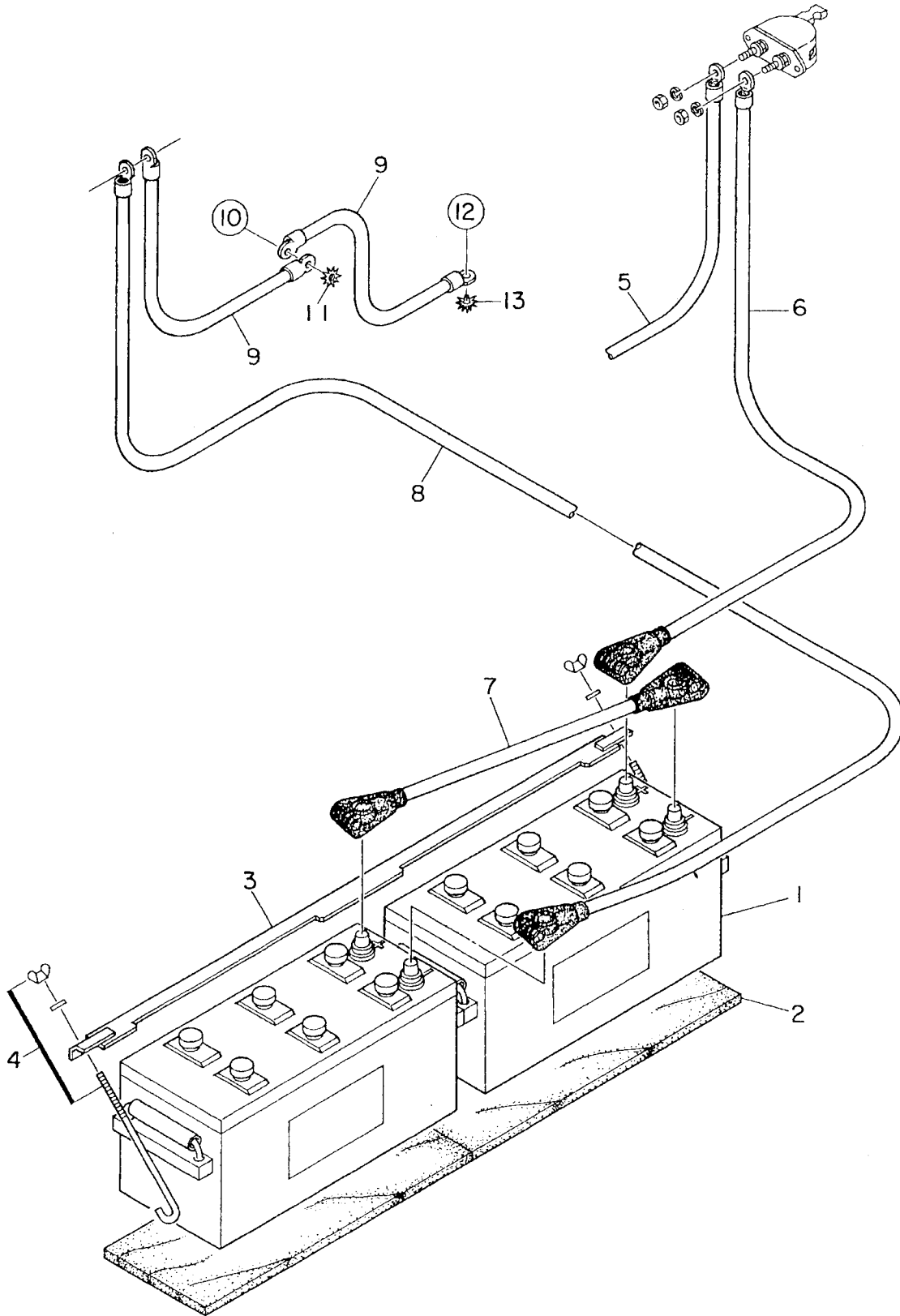

BATTERY ASSY. (DCA300SSCU)

<u>NO.</u>	<u>PART NO.</u>	<u>PART NAME</u>	<u>QTY.</u>	<u>REMARKS</u>
1	0602220196	BATTERY	2	
2	M9310500404	BATTERY SHEET	2	
3	M9104000004	BATTERY BAND	1	
4	0602220921	BATTERY BOLT SET	2	
5	M5346900404	BATTERY CABLE	1	
6	M5347900104	BATTERY CABLE	1	
7	M4346400314	BATTERY CABLE	1	
8	M5346900504	BATTERY CABLE	1	
9	M5346200104	EARTH CABLE	2	
10	0017116030	HEX HEAD BOLT	1	
11	0040516000	TOOTHED WASHER	1	
12	0017112025	HEX HEAD BOLT	1	
13	0040512000	TOOTHED WASHER	1	

MUFFLER ASSY.

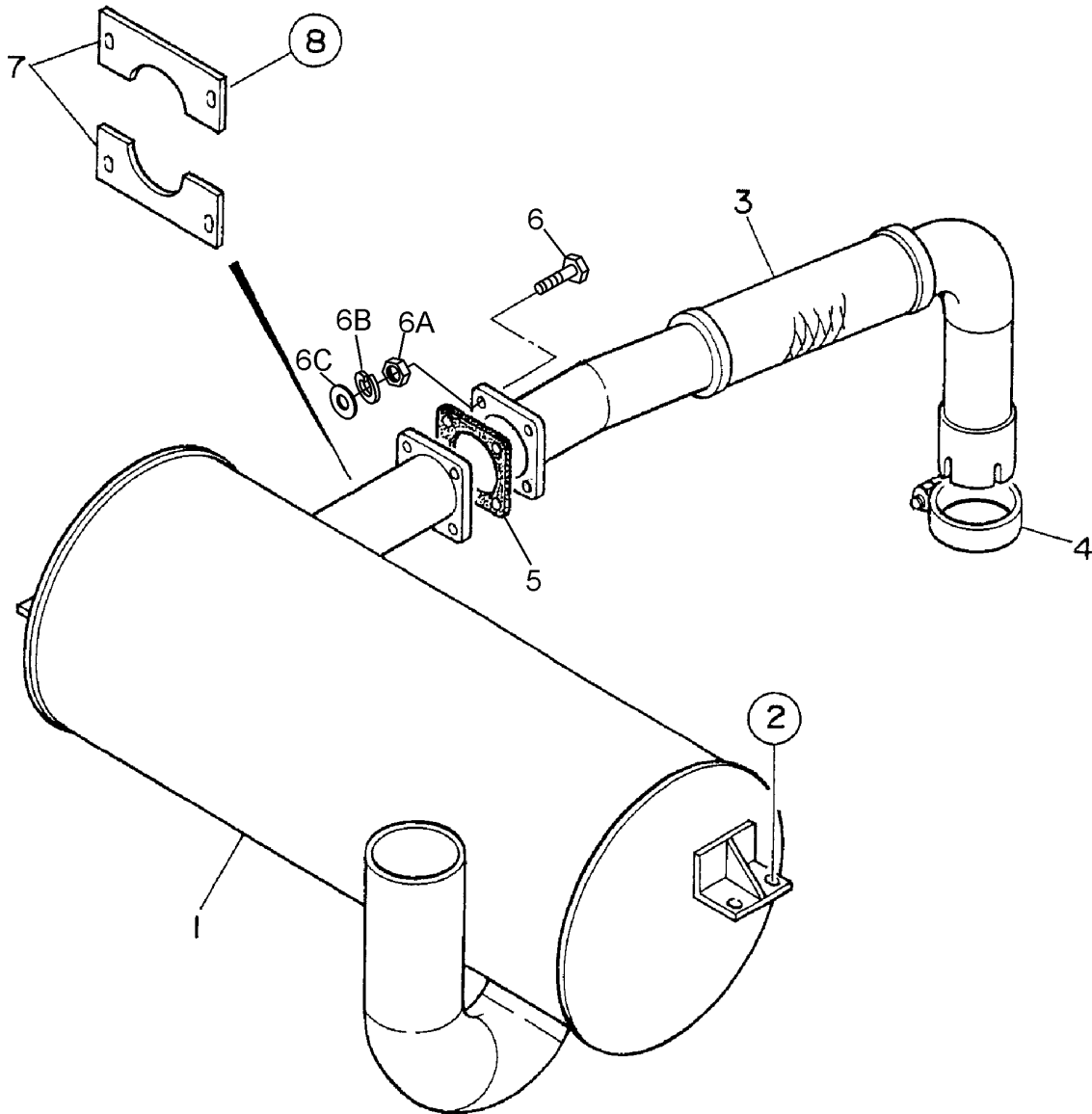

MUFFLER ASSY.

<u>NO.</u>	<u>PART NO.</u>	<u>PART NAME</u>	<u>QTY.</u>	<u>REMARKS</u>
1	C2331100002	MUFFLER	1	DCA300SSC
1	M5330100102	MUFFLER	1	DCA300SSCU
2	0019210025	HEX HEAD BOLT	4	
3	M5333000003	EXHAUST PIPE	1	
4	0602325066	BEND BOLT CLAMP	1	
5	C1334200304	GASKET	1	DCA300SSC
5	M4333200004	GASKET	1	DCA300SSCU
6	0010312055	HEX HEAD BOLT	4	
6A	0030312000	HEX NUT.....	4	DCA300SSC
6B	0042512000	WASHER, LOCK.....	4	DCA300SSC
6C	0041612000	WASHER, FLAT	8	DCA300SSC
7	C2331300004	COVER.....	2	DCA300SSC
7	M5331300004	COVER.....	2	DCA300SSCU
8	0017108020	HEX HEAD BOLT	4	

FUEL TANK ASSY. (DCA300SSC)

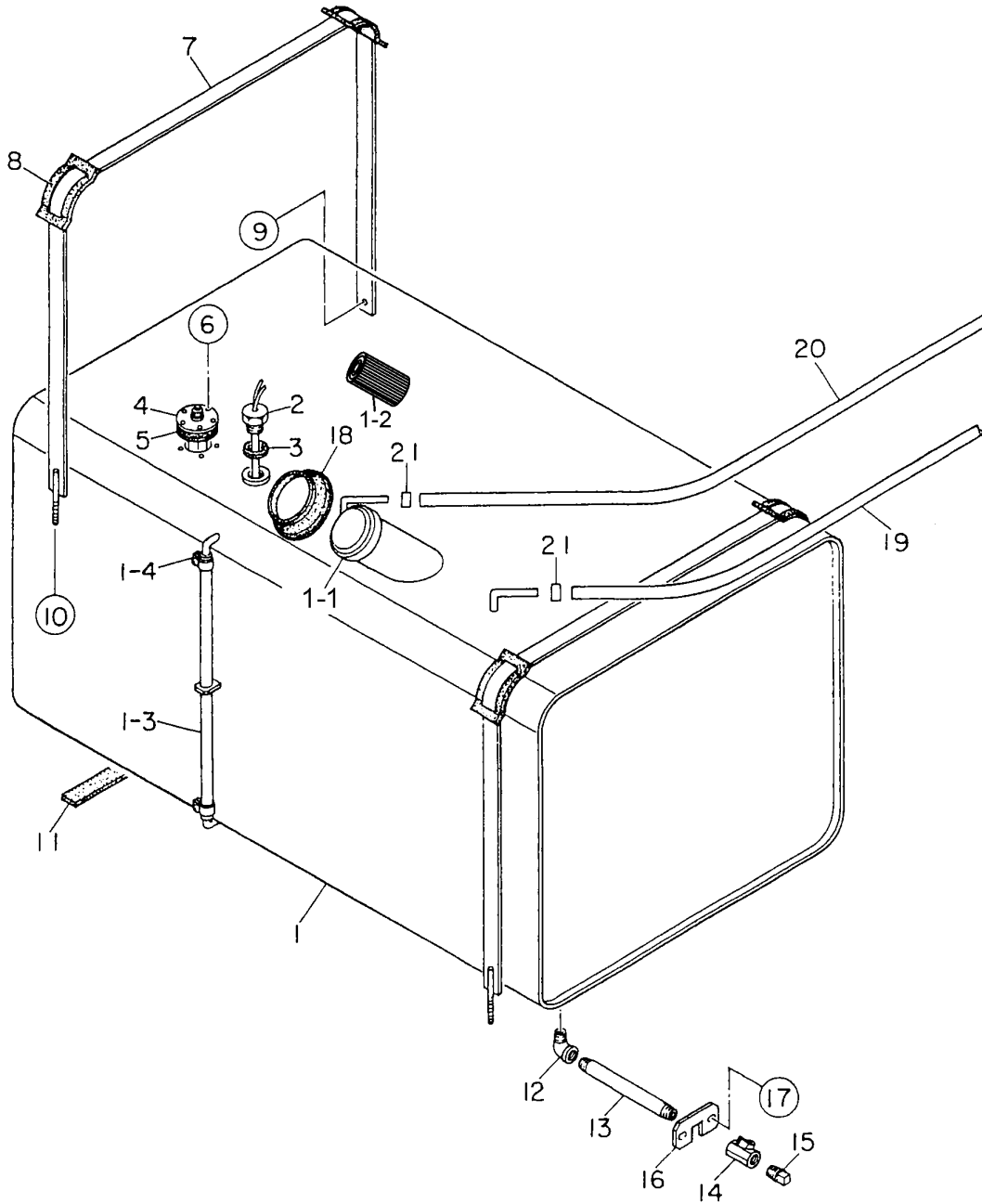

FUEL TANK ASSY. (DCA300SSC)

<u>NO.</u>	<u>PART NO.</u>	<u>PART NAME</u>	<u>QTY.</u>	<u>REMARKS</u>
1	C2363000303	FUEL TANK	1	
1-1	0810105004	CAP, FUEL TANK	1	
1-2	0810105400	FUEL FILTER	1	
1-3	0264100525	HOSE, FUEL GAUGE	1	
1-4	0605515079	HOSE BAND	2	
2	0605503023	FUEL SENSOR	1	
3	0802120604	PACKING	1	
4	0605501093	UNIT, FUEL	1	
5	0605516090	PACKING	1	
6	0022905015	MACHINE SCREW	5	
7	8195523104	TANK BAND	2	
8	0805003414	PAD, TANK BAND	4	
9	0017108020	HEX HEAD BOLT	4	
10	0207308000	SUPER LOCK NUT	2	
11	0222100300	TANK SHEET	6	
12	0130206000	STREET ELBOW, 1/2"	1	
13	0134306170	DRAIN PIPE	1	
14	0603325026	VALVE	1	
15	0132006000	PLUG, 1/2"	1	
16	C1367700304	LOCK PLATE	1	
17	0019208020	HEX HEAD BOLT	2	
18	0845039604	RUBBER SEAL	1	
19	0191503400	SUCTION HOSE	1	
20	0191503700	RETURN HOSE	1	
21	0605515073	HOSE BAND	4	

FUEL TANK ASSY. (DCA300SSCU)

<u>NO.</u>	<u>PART NO.</u>	<u>PART NAME</u>	<u>QTY.</u>	<u>REMARKS</u>
1	M5363000202	FUEL TANK	1	
1-1	0605505070	CAP, FUEL TANK	1	
2	0605501069	FUEL SENSOR UNIT	1	
3	0605516090	GASKET	1	
4	0027104016	MACHINE SCREW	5	
5	M5364200004	TANK BAND	2	
6	M9310500104	SUPPORTER SHEET	4	
7	0016908020	HEX HEAD BOLT	2	
8	0207308000	SUPER LOCK NUT	2	
9	0222100300	RUBBER TANK SHEET	6	
10	M9200000003	DRAIN JOINT	1	
11	M9200200004	DRAIN BOLT	1	
12	0150000018	O-RING	1	
13	0016908020	HEX HEAD BOLT	2	
14	M1363400104	DRAIN HOSE	1	
15	0605515198	HOSE BAND	2	
16	0602042682	CONNECTION	1	
17	0602042683	CONNECTION	1	
18	0191503400	HOSE, SUCTION	1	
19	0191503700	HOSE, RETURN	1	
20	0605515198	HOSE BAND	4	

ENCLOSURE ASSY.

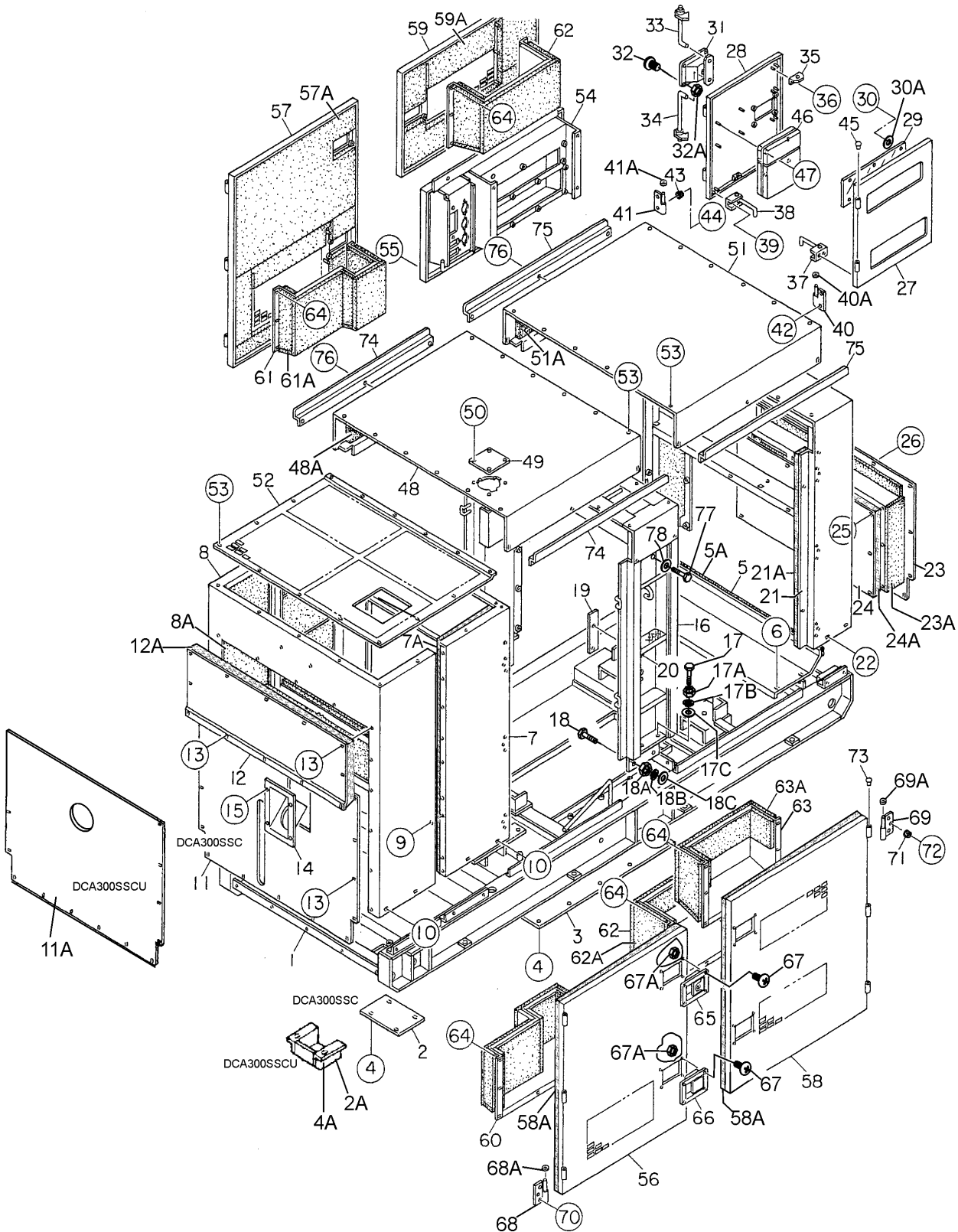

ENCLOSURE ASSY.

<u>NO.</u>	<u>PART NO.</u>	<u>PART NAME</u>	<u>QTY.</u>	<u>REMARKS</u>
1	C2413003202	BASE.....	1	DCA300SSC
1	M5413000004	BASE.....	1	DCA300SSCU
2	C3414100104	FLOOR PANEL.....	1	DCA300SSC
2A	M1413400004	FLOOR PANEL.....	1	DCA300SSCU
3	C2414100004	FLOOR PANEL.....	1	DCA300SSC
3	M5413100204	FLOOR PANEL.....	1	DCA300SSCU
4	0019208020	HEX HEAD BOLT	14	DCA300SSC
4A	0019208020	HEX HEAD BOLT	12	DCA300SSCU
5	C2414600304	DUCT	1	DCA300SSC
5	M5413600104	DUCT	1	DCA300SSCU
5A	C2494000304	ACOUSTIC SHEET	1	DCA300SSC
5A	M5493000004	ACOUSTIC SHEET	1	DCA300SSCU
6	0017108020	HEX HEAD BOLT	4	DCA300SSC
6	0016908020	HEX HEAD BOLT	4	DCA300SSCU
7	M5423000002	FRONT FRAME	1	
7A	M5493100003	ACOUSTIC SHEET	1	
8	M5423000102	FRONT FRAME	1	
8A	M5493100003	ACOUSTIC SHEET	1	
9	0017108020	HEX HEAD BOLT	10	
10	0019210025	HEX HEAD BOLT	8	
11	C2424200003	COVER, FRONT FRAME.....	1	DCA300SSC
11A	M5424200203	COVER, FRONT FRAME.....	1	DCA300SSCU
12	C2424201504	COVER, FRONT FRAME.....	1	DCA300SSC
12	M5424200103	COVER, FRONT FRAME.....	1	DCA300SSCU
12A	C2494101104	ACOUSTIC SHEET	1	DCA300SSC
12A	M5494101604	ACOUSTIC SHEET	1	DCA300SSCU
13	0019208020	HEX HEAD BOLT	23	
14	0845042703	FILLER BRACKET	1	DCA300SSC
15	0019208020	HEX HEAD BOLT	4	DCA300SSC
16	M5433000002	CENTER FRAME	1	

ENCLOSURE ASSY. (CONTINUED)

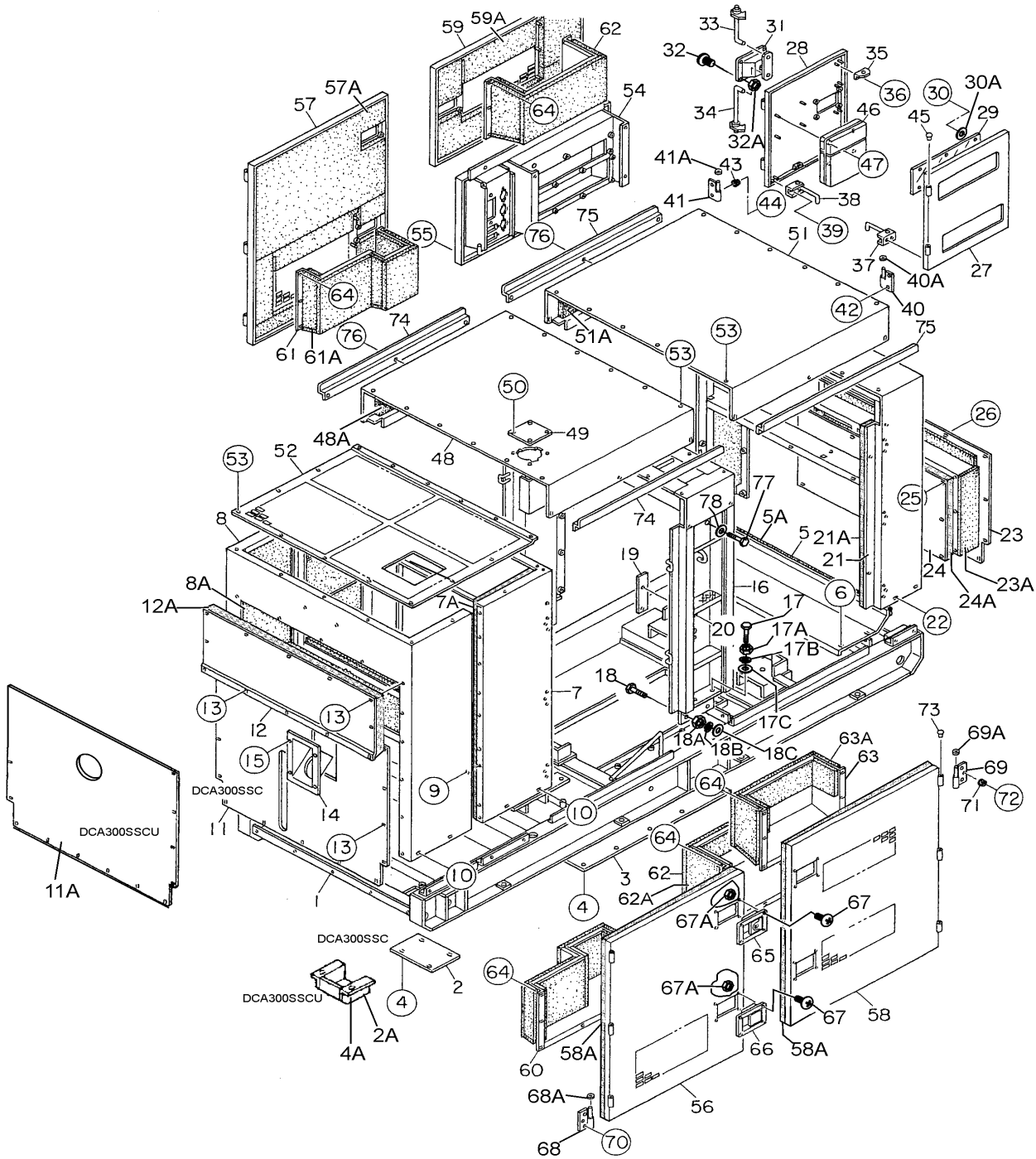

ENCLOSURE ASSY. (CONTINUED)

<u>NO.</u>	<u>PART NO.</u>	<u>PART NAME</u>	<u>QTY.</u>	<u>REMARKS</u>
17	0010114050	HEX HEAD BOLT	4	
17A	0030014000	HEX NUT	4	
17B	0040014000	WASHER, LOCK	4	
17C	0041214000	WASHER, FLAT	8	
18	0010114040	HEX HEAD BOLT	8	
18A	0030014000	HEX NUT	8	
18B	0040014000	WASHER, LOCK	8	
18C	0041214000	WASHER, FLAT	16	
19	C2367700404	COVER.....	1	DCA300SSC
19	M5366700204	COVER.....	1	DCA300SSCU
20	0019208020	HEX HEAD BOLT	2	
21	M5443000002	REAR FRAME	1	
21A	C2494300204	ACOUSTIC SHEET	1	DCA300SSC
21A	M5493300904	ACOUSTIC SHEET	1	DCA300SSCU
22	0019210025	HEX HEAD BOLT	4	
23	M5443300003	COVER, REAR FRAME	1	
23A	M5493300004	ACOUSTIC SHEET	1	
24	M5443300104	PANEL	1	
24A	M5493300104	ACOUSTIC SHEET	1	
25	0016908020	HEX HEAD BOLT	12	
26	0019208020	HEX HEAD BOLT	14	
27	M5453000003	DOOR, REAR FRAME	1	
28	M5453000103	DOOR, REAR FRAME	1	
29	8225147004	WINDOW PLATE.....	2	DCA300SSC
29	M5443600004	WINDOW PLATE.....	2	DCA300SSCU
30	0207306000	SELF- LOCKING U-NUT	12	
30A	0041206000	WASHER, FLAT	12	
31	B9114000102	DOOR HANDLE.....	1	DCA300SSC
31	M9113000202	DOOR HANDLE.....	1	DCA300SSCU
32	0021806016	MACHINE SCREW	4	
32A	0030006000	HEX NUT	4	

ENCLOSURE ASSY. (CONTINUED)

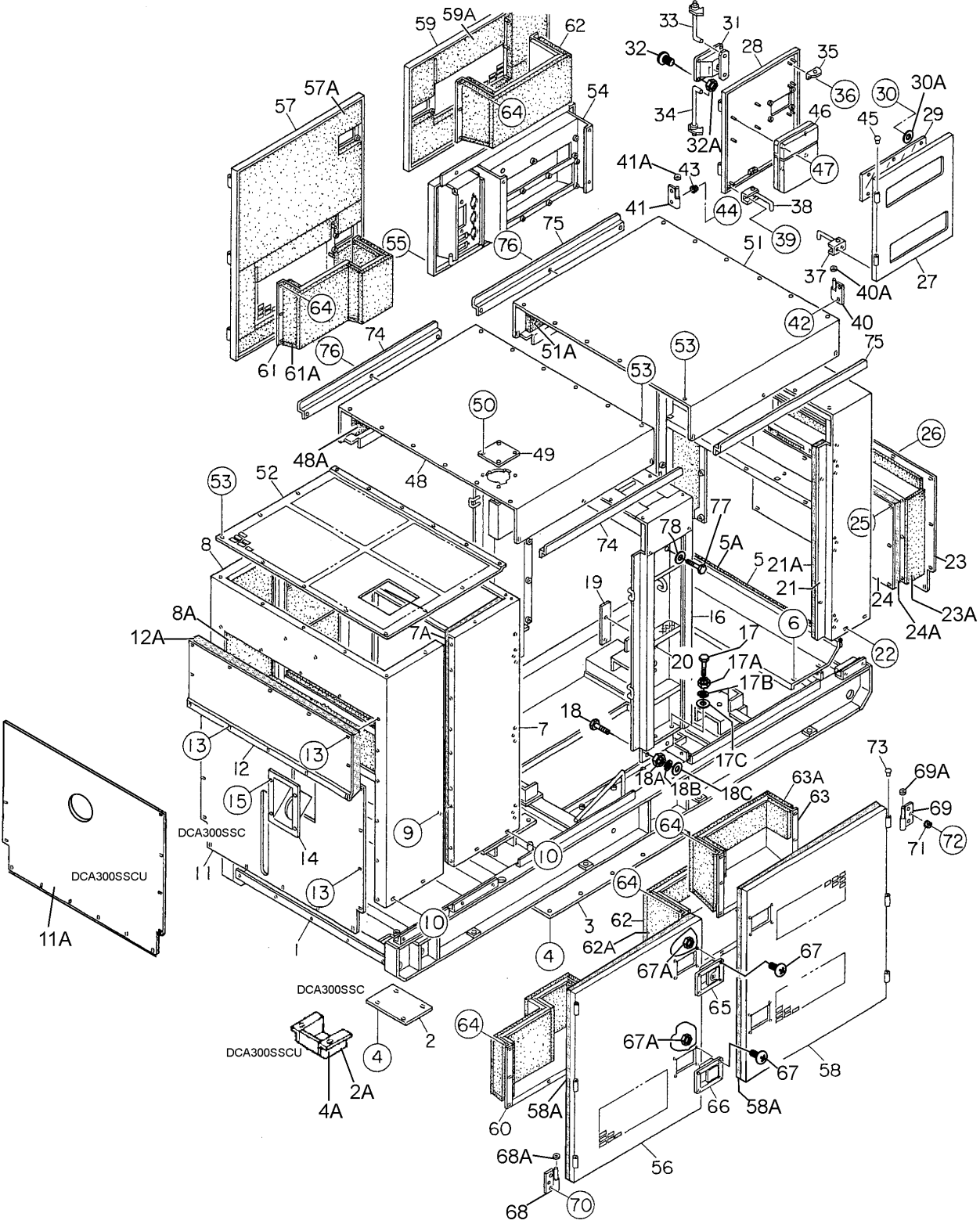

ENCLOSURE ASSY. (CONTINUED)

<u>NO.</u>	<u>PART NO.</u>	<u>PART NAME</u>	<u>QTY.</u>	<u>REMARKS</u>
33	C3444700004	DOOR ROD	1	DCA300SSC
33	M9114300004	DOOR ROD.....	1	DCA300SSCU
34	8195146304	DOOR ROD.....	1	DCA300SSC
34	M9114300104	DOOR ROD.....	1	DCA300SSCU
35	0845050704	STAY	4	DCA300SSC
35	M9113300004	STAY	4	DCA300SSCU
36	0207006000	HEX NUT	8	
37	0805011304	STOPPER, DOOR.....	1	DCA300SSC
37	M9113400104	STOPPER, DOOR.....	1	DCA300SSCU
38	0805011204	STOPPER, DOOR.....	1	DCA300SSC
38	M113400204	STOPPER, DOOR.....	1	DCA300SSCU
39	0207006000	HEX NUT	4	
40	M9110100204	HINGE	2	
40A	0845045004	WASHER.....	2	DCA300SSC
40A	M9116100004	WASHER.....	2	DCA300SSCU
41	M9110100304	HINGE	2	
41A	0845045004	WASHER.....	2	DCA300SSC
41A	M9116100004	WASHER.....	2	DCA300SSCU
42	0019208020	HEX HEAD BOLT	6	
43	0601850097	STOPPER	2	
44	0025408025	MACHINE SCREW	2	
45	0845031504	CAP	4	
45	M9310000004	CAP	4	
46	0600800320	MANUAL PAK	1	
47	0207006000	HEX NUT	4	
48	M5463100002	ROOF PANEL	1	
48A	M5493500004	ACOUSTIC SHEET	1	
49	M3310600004	COVER	1	
50	0019208020	HEX HEAD BOLT	4	
51	C2464200502	ROOF PANEL.....	1	DCA300SSC
51	M5463200102	ROOF PANEL.....	1	DCA300SSCU
51A	C2494500904	ACOUSTIC SHEET	1	DCA300SSC
51A	M5493502004	ACOUSTIC SHEET	1	DCA300SSCU
52	M5423200103	COVER, FRONT FRAME	1	
53	0019208020	HEX HEAD BOLT	41	
54	M5453200002	SPLASHER PANEL	1	
55	0019208065	HEX HEAD BOLT	6	

ENCLOSURE ASSY. (CONTINUED)

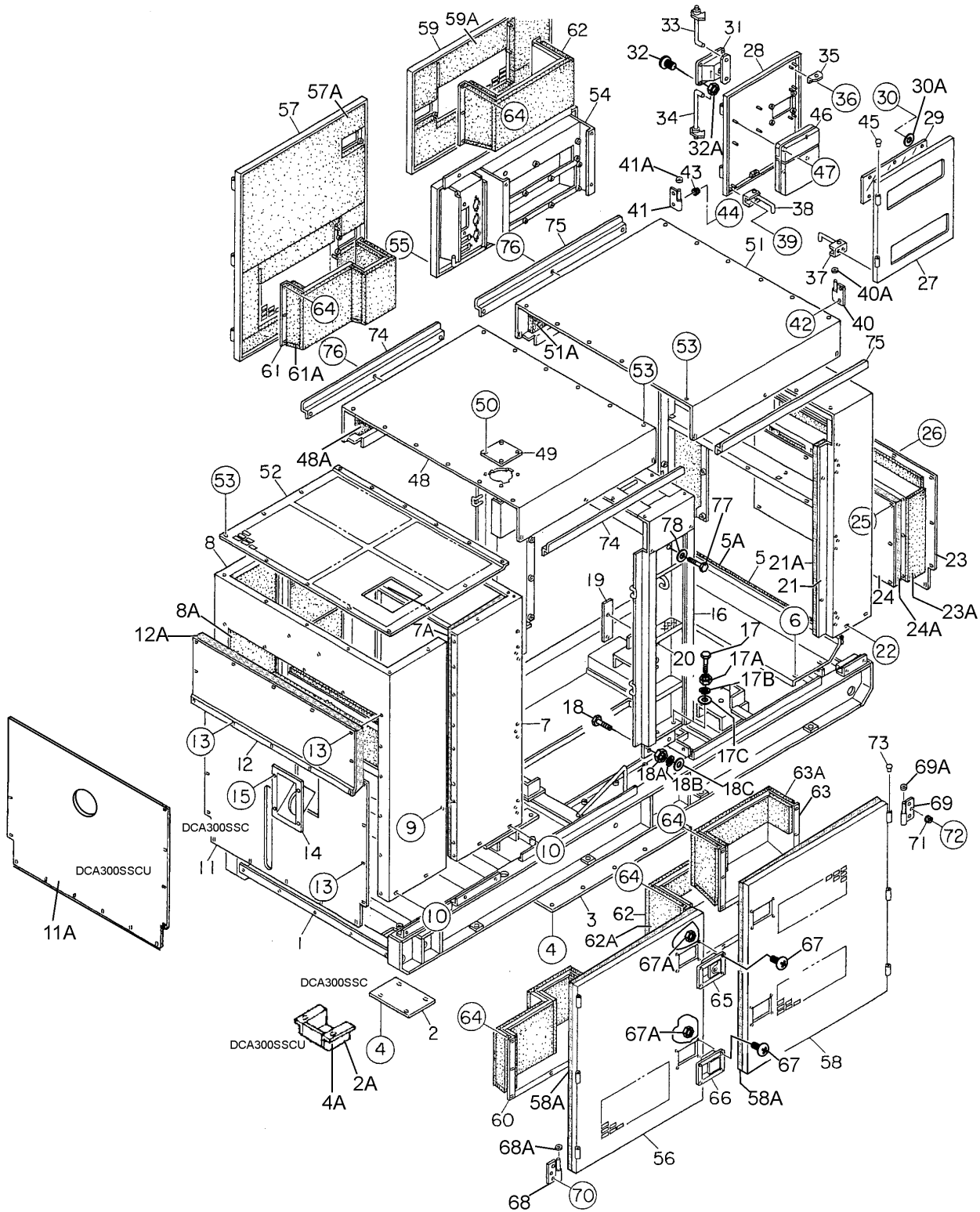

ENCLOSURE ASSY. (CONTINUED)

<u>NO.</u>	<u>PART NO.</u>	<u>PART NAME</u>	<u>QTY.</u>	<u>REMARKS</u>
56	M5453000203	SIDE PANEL	1	
56A	M5493400004	ACOUSTIC SHEET	1	
57	M5453000303	SIDE PANEL	1	
57A	M5493400104	ACOUSTIC SHEET	1	
58	M5453000803	SIDE PANEL	1	
58A	M5493409304	ACOUSTIC SHEET	1	
59	M5453000903	SIDE PANEL	1	
59A	M5493409404	ACOUSTIC SHEET	1	
60	M5453300004	DUCT	1	
60A	M5493400204	ACOUSTIC SHEET	1	
61	M5453300104	DUCT	1	
61A	M5493400304	ACOUSTIC SHEET	1	
62	M5453300904	DUCT	2	
62A	M5493409504	ACOUSTIC SHEET	2	
63	M5453300204	DUCT	1	
63A	M5493400404	ACOUSTIC SHEET	1	
64	0207008000	HEX NUT	35	
65	B9114000002	DOOR HANDLE	4	DCA300SSC
65	M9113000002	DOOR HANDLE	4	DCA300SSCU
66	0825007362	DOOR HANDLE.....	3	DCA300SSC
66	M9113000102	DOOR HANDLE.....	3	DCA300SSCU
67	0021806016	MACHINE SCREW	28	
67A	0030006000	HEX NUT	16	
68	0845046904	HINGE	5	DCA300SSC
68	M9110100804	HINGE	5	DCA300SSCU
68A	0845045004	WASHER.....	5	DCA300SSC
68A	M9116100004	WASHER.....	5	DCA300SSCU
69	084504700	HINGE	6	DCA300SSC
69	M9110100904	HINGE	6	DCA300SSCU
69A	0845045004	WASHER.....	6	DCA300SSC
69A	M9116100004	WASHER.....	6	DCA300SSCU
70	0019208020	HEX HEAD BOLT	25	
71	0601850097	STOPPER	8	
72	0025408025	MACHINE SCREW	8	
73	0845031504	CAP	11	DCA300SSC
73	M9310000004	CAP	11	DCA300SSCU
74	M5463500004	GUTTER.....	2	
75	C2464500304	GUTTER.....	2	DCA300SSC
75	M5463500104	GUTTER.....	2	DCA300SSCU
76	0019208020	HEX HEAD BOLT	4	
77	0019116025	HEX HEAD BOLT	1	DCA300SSCU
78	0042416000	WASHER, FLAT	1	DCA300SSCU

RUBBER SEALS ASSY.

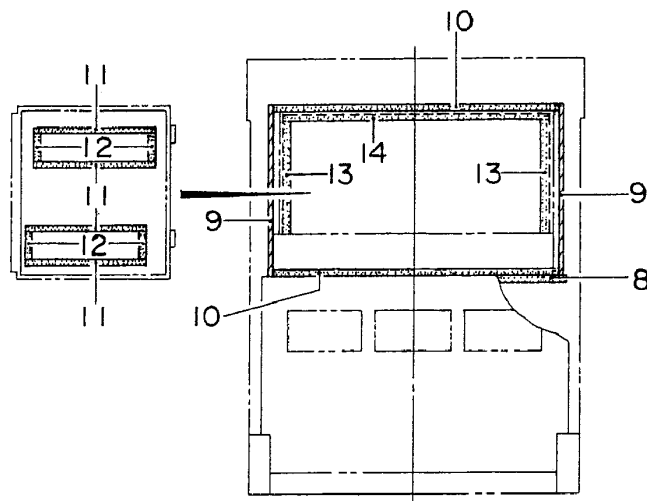
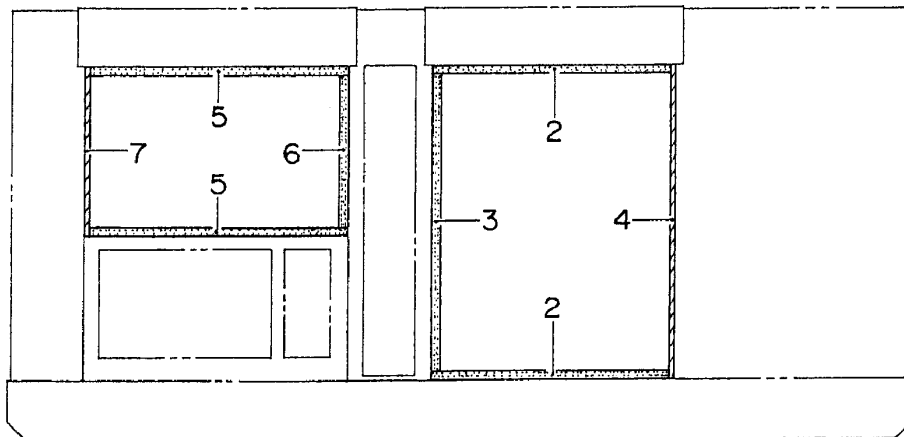
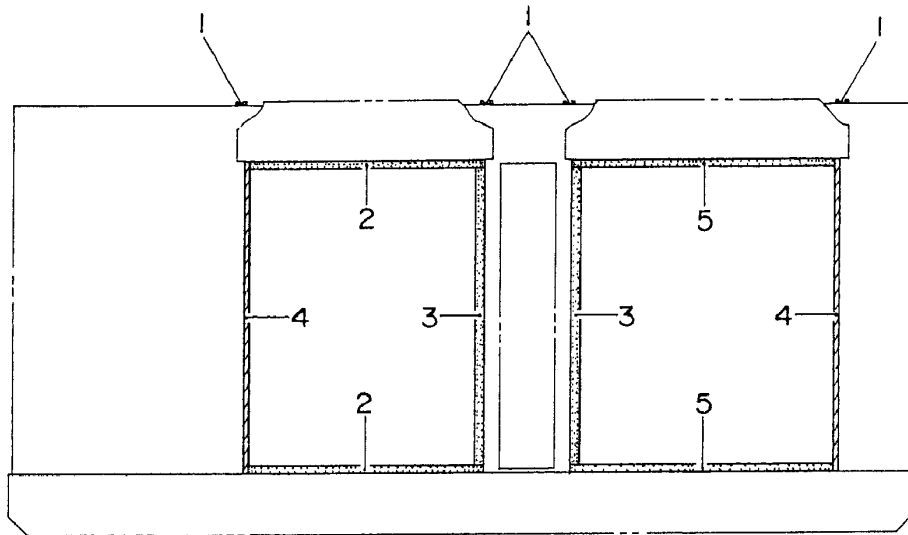

RUBBER SEALS ASSY.

<u>NO.</u>	<u>PART NO.</u>	<u>PART NAME</u>	<u>QTY.</u>	<u>REMARKS</u>
1	0229201400	SEAL RUBBER	4	
2	0228901015	SEAL RUBBER	4	
3	0228901250	SEAL RUBBER	3	
4	0228901310	SEAL RUBBER	3	
5	0228900650	SEAL RUBBER.....	4DCA300SSC
5	0228900650	SEAL RUBBER.....	4DCA300SSCU
6	0228900650	SEAL RUBBER	1	
7	0228900710	SEAL RUBBER	1	
8	0229201300	SEAL RUBBER	1	
9	0221200705	SEAL RUBBER	2	
10	0228801210	SEAL RUBBER	2	
11	0228100510	SEAL RUBBER	4	
12	0228100120	SEAL RUBBER	4	
13	0229200470	SEAL RUBBER	2	
14	0229201130	SEAL RUBBER	1	

NAMEPLATE AND DECALS ASSY. (DCA300SSC)

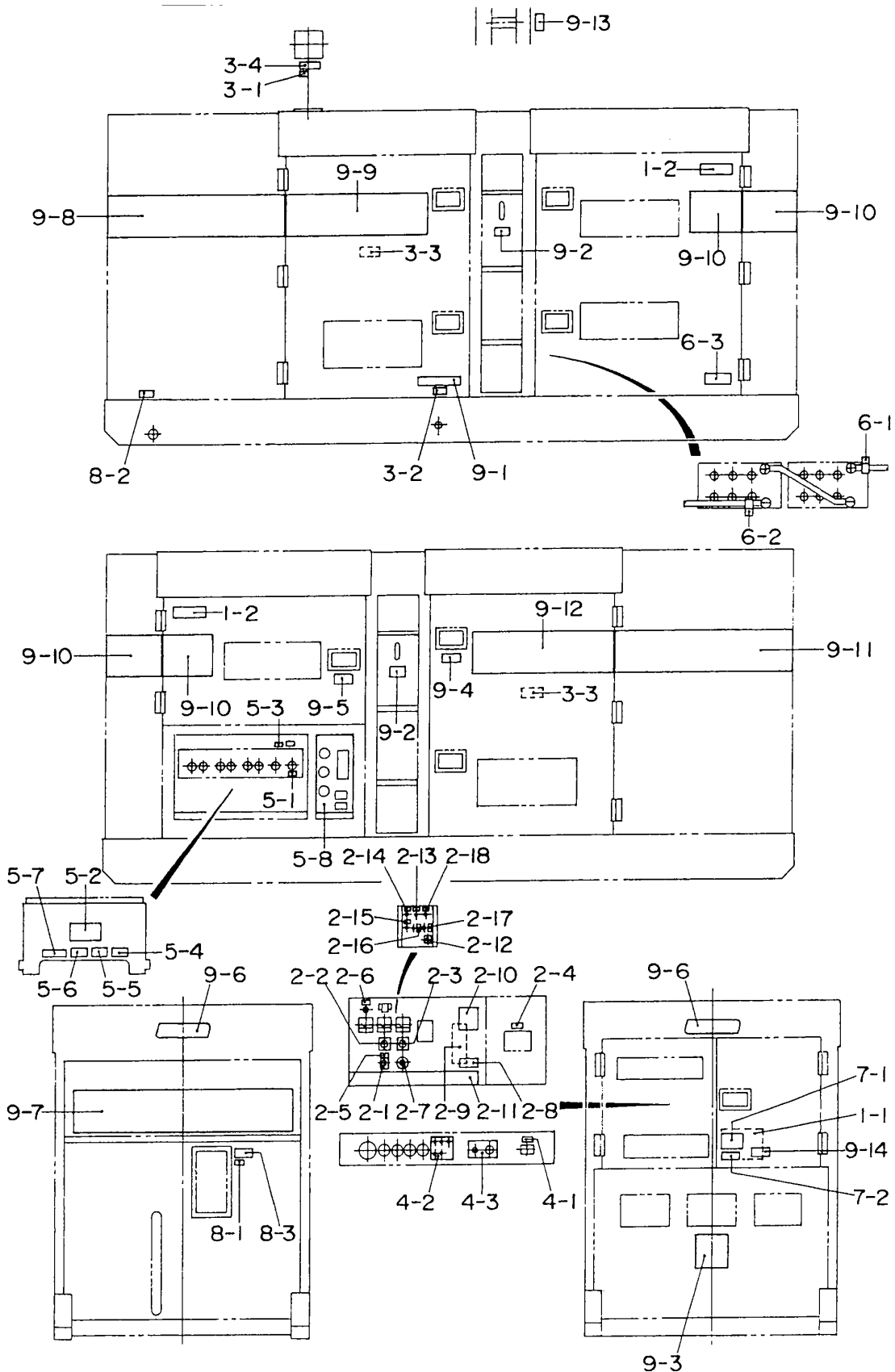

NAMEPLATE AND DECALS ASSY. (DCA300SSC)

<u>NO.</u>	<u>PART NO.</u>	<u>PART NAME</u>	<u>QTY.</u>	<u>REMARKS</u>
1-1	C3550000703	DECAL : HANDLING PROCEDURES	1	C35000070
1-2	C9522100003	DECAL : CAUTION	2	C92210000
CONTROL BOX GROUP				
2-1	0800520100	PLATE : ON - OFF.....	1	AT-202
2-2	0800520904	PLATE : AMMETER CHANGE- OVER SWITCH.....	1	N-2438
2-3	0800520814	PLATE : VOLTMETER CHANGE- OVER SWITCH	1	N-2439
2-4	0840624504	DECAL : CIRCUIT BREAKER	1	S-3031
2-5	0840624604	DECAL : PANEL LIGHT SWITCH	1	S-3032
2-6	0840624704	DECAL : PILOT LAMP	1	S-3033
2-7	0840624804	DECAL : VOLTAGE REGULATOR.....	1	S-3034
2-8	B9531100604	DECAL : WARNING ELECTRIC SHOCK HAZARD	1	B93110060
2-9	C0551000903	DECAL : SETTING FOR OUTPUT VOLTAGE.....	1	C05100090
2-10	C2551000004	DECAL : SAFETY INSTRUCTIONS	1	C25100000
2-11	M5560100903	DECAL : WHISPERWATT 300	1	M56010090A
2-12	C9502400004	DECAL : HIGH IDLE SPEED	1	C90240000
2-13	C9520027704	DECAL : DIAGNOSTIC BUTTON	1	C92002770
2-14	C9520028604	DECAL : WARNING DIAGNOSTIC LAMP	1	C92002860
2-15	C9520028704	DECAL : SHUTDOWN DIAGNOSTIC LAMP	1	C92002870
2-16	C9520028804	DECAL : LOW IDLE SPEED / DIAG. CODE SW.....	1	C92002880
2-17	C9521007504	DECAL : DIAGNOSTIC SWITCH.....	1	C92100750
2-18	Z0110001504	DECAL : RESET	1	Z01000150
ENGINE & RADIATOR GROUP				
3-1	6360610304	DECAL : WATER	1	S-1880
3-2	6360620204	DECAL : OIL DRAIN PLUG	1	S-1885
3-3	B9504000404	DECAL : MOVING PARTS	2	B90400040
3-4	B9504100104	DECAL : WARNING HOT COOLANT	1	B90410010
ENGINE OPERATING PANEL GROUP				
4-1	C0551000504	DECAL : BATTERY SWITCH	1	C05100050
4-2	C3550000404	DECAL : ALARM LAMP	1	C35000040
4-3	M5550000503	DECAL : OPERATING PANEL	1	M55000050
OUTPUT TERMINAL GROUP				
5-1	0840614104	DECAL : GROUND	1	S-2635
5-2	0840619904	DECAL : DANGER HIGH VOLTAGE	1	S-2731
5-3	9039209064	DECAL : START CONTACT	1	S-4468
5-4	B9511100304	DECAL : WARNING	1	B91110030
5-5	B9511100404	DECAL : WARNING ELECTRIC SHOCK HAZARD	1	B91110040
5-6	B9531100504	DECAL : WARNING ELECTRIC SHOCK HAZARD	1	B93110050
5-7	C0551000404	DECAL : 3- PHASE OUTPUT TERMINAL	1	C05100040
5-8	C1551000803	DECAL : RECEPTACLE & CIRCUIT BREAKER.....	1	C15100080

NAMEPLATE AND DECALS ASSY. (CONTINUED DCA300SSC)

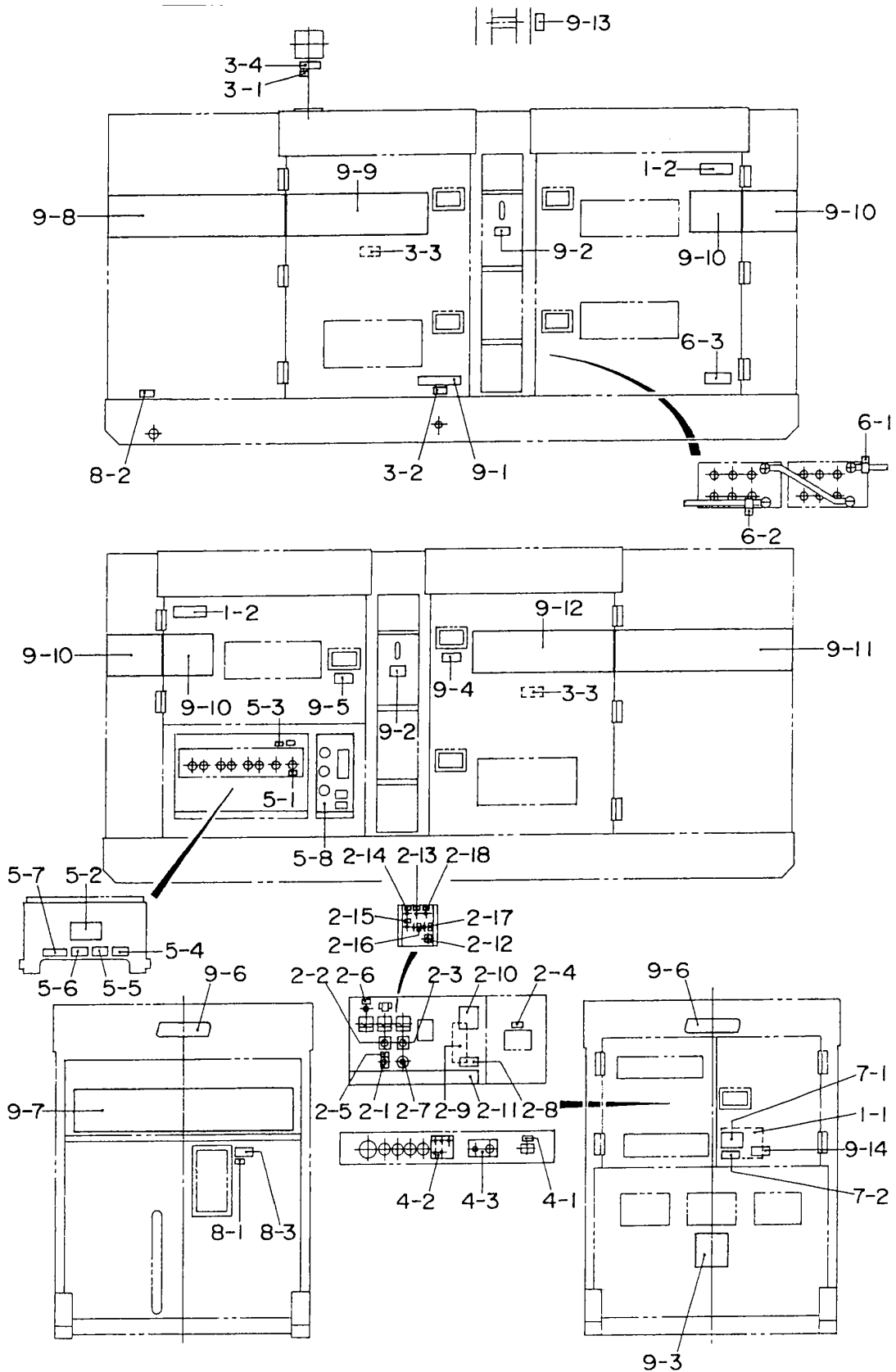

NAMEPLATE AND DECALS ASSY. (CONTINUED DCA300SSC)

NO.	PART NO.	PART NAME	QTY.	REMARKS
BATTERY GROUP				
6-1	0800689404	DECAL : +	1.....	S-2090
6-2	0800689504	DECAL : -	1.....	S-2091
6-3	C9505300004	DECAL : CAUTION	1.....	C90530000
MUFFLER GROUP				
7-1	A9504000014	DECAL : DANGER.....		A90400001
7-2	B9504200004	DECAL : WARNING ENGINE EXHAUST.....	1.....	B90420000
FUEL TANK GROUP				
8-1	1320620904	DECAL : DIESEL FUEL	1.....	S-1756
8-2	6360620004	DECAL : FUEL DRAIN PLUG	1.....	S-1883
8-3	B9504500004	DECAL : WARNING DIESEL FUEL	1.....	B90450000
ENCLOSURE GROUP				
9-1	1320610603	DECAL : WATER - OIL	1.....	S-1760
9-2	1320621504	DECAL : SUPPORT HOOK	2.....	S-2257
9-3	0840625902	DECAL : MQ	1.....	S-3057
9-4	B9504000304	DECAL : CAUTION HOT PARTS	1.....	B90400030
9-5	B9531100604	DECAL : WARNING ELECTRIC SHOCK HAZARD	1.....	B93110060
9-6	0600500090	EMBLEM	2	
9-6A	0021106016	MACHINE SCREW	4	
9-7	M5560101503	STRIPE	1	
9-8	M5560101303	STRIPE	1	
9-9	M5560101103	STRIPE	1	
9-10	M5560101004	STRIPE	4	
9-11	M5560101403	STRIPE	1	
9-12	M5560101203	STRIPE	1	
9-13	C9504000304	DECAL : CAUTION	1.....	C90400030
9-14	M9504200004	DECAL : WARNING START FIRES	1.....	M90420000

NAMEPLATE AND DECALS ASSY. (DCA300SSCU)

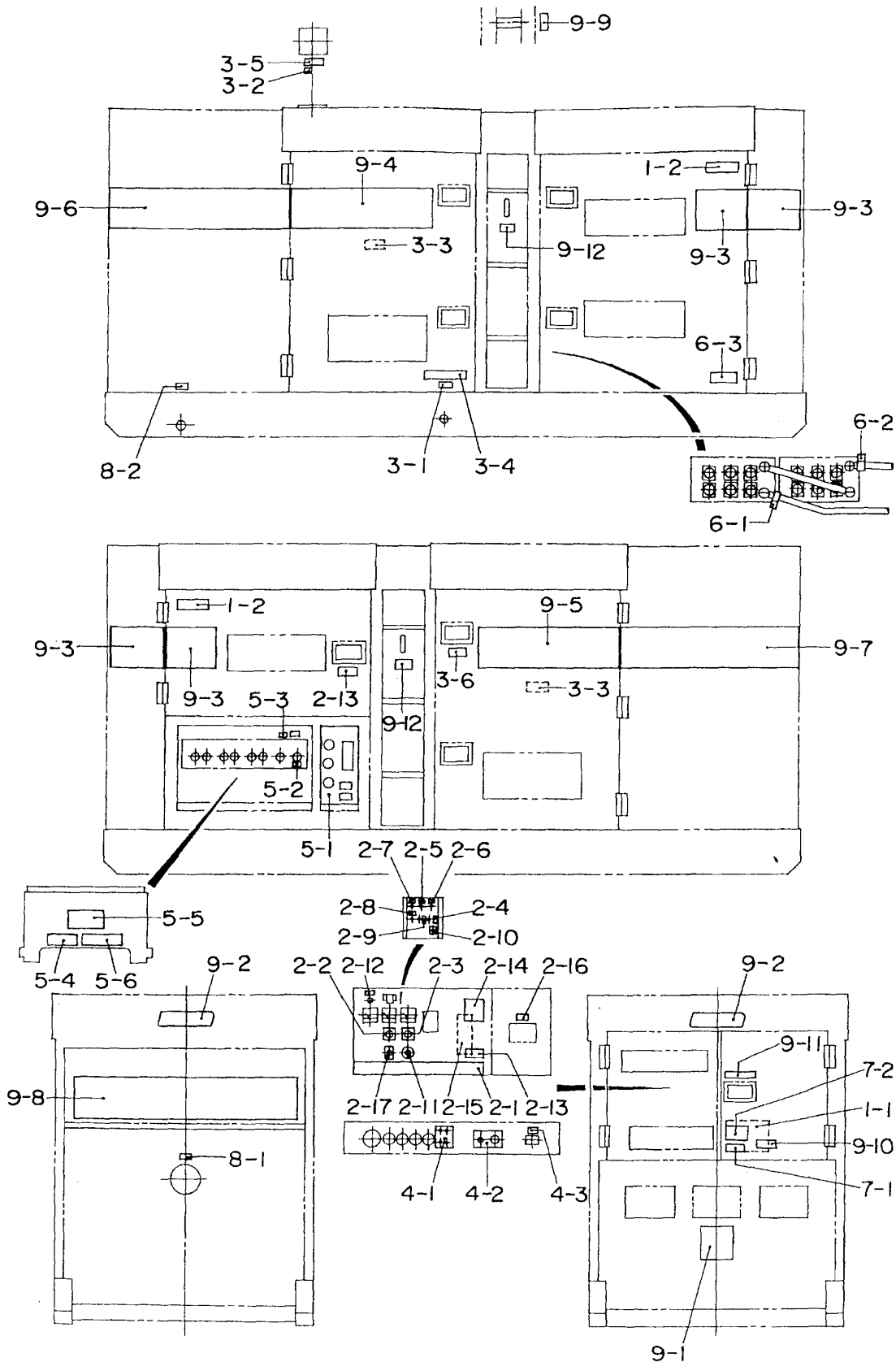

NAMEPLATE AND DECALS ASSY. (DCA300SSCU)

<u>NO.</u>	<u>PART NO.</u>	<u>PART NAME</u>	<u>QTY.</u>	<u>REMARKS</u>
1-1	M5550000303	DECAL : HANDLING PROCEDURES	1	M55000030
1-2	M9520100603	DECAL : CAUTION	2	M92010060
CONTROL BOX GROUP				
2-1	M5560100903	DECAL : WHISPERWATT 300	1	M56010090A
2-2	M9520000104	PLATE : AMMETER CHANGE-OVER SWITCH.....	1	M92000010
2-3	M9520000204	PLATE : VOLTMETER CHANGE-OVER SWITCH	1	M92000020
2-4	M9520000904	DECAL : DIAGNOSTIC SWITCH.....	1	M92000090
2-5	M9520001104	DECAL : DIAGNOSTIC BUTTON	1	M92000110
2-6	M9520001504	DECAL : RESET	1	M92000150
2-7	M9520001804	DECAL : WARNING DIAGNOSTIC LAMP	1	M92000180
2-8	M9520001904	DECAL : SHUTDOWN DIAGNOSTIC LAMP	1	M92000190
2-9	M9520001904	DECAL : LOW IDLE SPEED/DIAG. CODE SWITCH... 1	1	M92000200
2-10	M9522000404	DECAL : HIGH IDLE SPEED	1	M92200040
2-11	M9520001304	DECAL : VOLTAGE REGULATOR.....	1	M92000130
2-12	M9520001404	DECAL : PILOT LAMP	1	M92000140
2-13	M9520100004	DECAL : WARNING ELECTRIC SHOCK HAZ.....	1	M92010000
2-14	M9520100304	DECAL : GENERAL CAUTION	1	M92010030
2-15	M9520200303	DECAL : SETTING FOR OUTPUT VOLTAGE.....	1	M92020030
2-16	M9522000504	DECAL : CIRCUIT BREAKER.....	1	M92200050
2-17	M9522000704	DECAL : PANEL LIGHT SWITCH	1	M92200070
ENGINE & RADIATOR GROUP				
3-2	M9500000004	DECAL : OIL DRAIN PLUG	1	M90000000
3-1	M9500100004	DECAL : WATER	1	M90010000
3-3	M9503000004	DECAL : MOVING PARTS	2	M90300000
3-4	M9510100004	DECAL : WATER OIL	1	M91010000
3-5	M9503100004	DECAL : WARNING RADIATOR CAP	1	M90310000
3-6	M9510100004	DECAL : HIGH TEMP	1	M91010000
ENGINE OPERATING PANEL GROUP				
4-1	M5550000103	DECAL : ALARM LAMP	1	M55000010
4-3	M5550000503	DECAL : OPERATING PANEL	1	M55000050
4-1	M9520001604	DECAL : BATTERY SWITCH	1	M92000160
OUTPUT TERMINAL GROUP				
5-1	M4550000103	DECAL : AUXILIARY OUTPUTS.....	1	M45000010
5-2	M9520000004	DECAL : GROUNDING.....	1	M92000000
5-3	M9520000504	DECAL : START CONTACT	1	M92000050
5-4	M9520000704	DECAL : 3-PHASE OUTPUT TERMINAL	1	M92000070
5-5	M9520100404	DECAL : DANGER HIGH VOLTAGE	1	M92010040
5-6	M9520100503	DECAL : WARNING ELECTRIC SHOCK HAZARD.....	1	M92010050

NAMEPLATE AND DECALS ASSY. (CONTINUED DCA300SSCU)

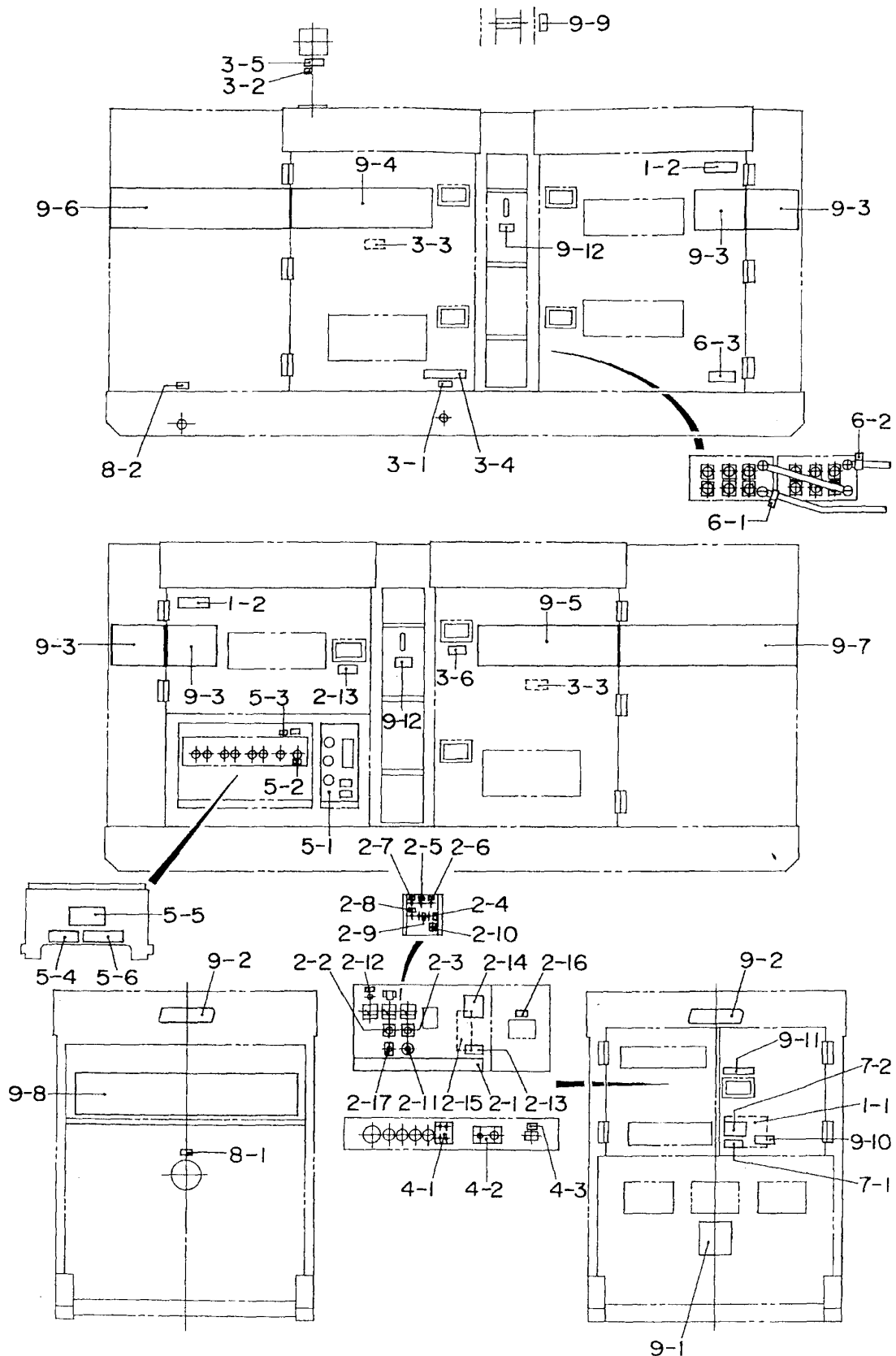

NAMEPLATE AND DECALS ASSY. (CONTINUED DCA300SSCU)

NO.	PART NO.	PART NAME	QTY.	REMARKS
BATTERY GROUP				
6-1	M9500300004	DECAL : -	1.....	M90030000
6-2	M9500300104	DECAL : +	1.....	M90030010
6-3	M9510100403	DECAL : WARNING BATTERY CONNECT	1.....	M91010040A
MUFFLER GROUP				
7-1	M9503200004	DECAL : WARNING ENGINE EXHAUST.....		M90320000
7-2	M9503200104	DECAL : DANGER EXHAUST GAS INDOOR	1.....	M90320010
FUEL TANK GROUP				
8-1	M9500500004	DECAL : DIESEL FUEL	1.....	M95005000
8-2	M9500500104	DECAL : FUEL DRAIN PLUG	1.....	M950050010
ENCLOSURE GROUP				
9-1	M9510200002	DECAL : MQ	1.....	M91020000
9-2	0600500090	EMBLEM	2	
9-2A	0021106016	MACHINE SCREW	4	
9-3	M5560101004	STRIPE	1	
9-4	M5560101103	STRIPE	1	
9-5	M5560101203	STRIPE	1	
9-6	M5560101303	STRIPE	4	
9-7	M5560101403	STRIPE	1	
9-8	M5561100403	STRIPE	1	
9-9	M5550000004	DECAL : CAUTION LIFTING CAP	1.....	M55000000
9-10	M9504200004	DECAL : WARNING START FIRES	1.....	M90420000
9-11	M9510000104	DECAL : DOCUMENT BOX LOCATED.....	1.....	M91000010
9-12	M9512000004	DECAL : SUPPORT HOOK	2.....	M91200000

TERMS AND CONDITIONS OF SALE — PARTS

PAYMENT TERMS

Terms of payment for parts are net 30 days.

FREIGHT POLICY

All parts orders will be shipped collect or prepaid with the charges added to the invoice. All shipments are F.O.B. point of origin. Multiquip's responsibility ceases when a signed manifest has been obtained from the carrier, and any claim for shortage or damage must be settled between the consignee and the carrier.

MINIMUM ORDER

The minimum charge for orders from Multiquip is \$15.00 net. Customers will be asked for instructions regarding handling of orders not meeting this requirement.

RETURNED GOODS POLICY

Return shipments will be accepted and credit will be allowed, subject to the following provisions:

1. A Returned Material Authorization must be approved by Multiquip prior to shipment.
2. To obtain a Return Material Authorization, a list must be provided to Multiquip Parts Sales that defines item numbers, quantities, and descriptions of the items to be returned.
 - a. The parts numbers and descriptions must match the current parts price list.
 - b. The list must be typed or computer generated.
 - c. The list must state the reason(s) for the return.
 - d. The list must reference the sales order(s) or invoice(s) under which the items were originally purchased.
 - e. The list must include the name and phone number of the person requesting the RMA.
3. A copy of the Return Material Authorization must accompany the return shipment.
4. Freight is at the sender's expense. All parts must be returned freight prepaid to Multiquip's designated receiving point.

5. Parts must be in new and resalable condition, in the original Multiquip package (if any), and with Multiquip part numbers clearly marked.
6. The following items are not returnable:
 - a. Obsolete parts. (If an item is in the price book and shows as being replaced by another item, it is obsolete.)
 - b. Any parts with a limited shelf life (such as gaskets, seals, "O" rings, and other rubber parts) that were purchased more than six months prior to the return date.
 - c. Any line item with an extended dealer net price of less than \$5.00.
 - d. Special order items.
 - e. Electrical components.
 - f. Paint, chemicals, and lubricants.
 - g. Decals and paper products.
 - h. Items purchased in kits.
7. The sender will be notified of any material received that is not acceptable.
8. Such material will be held for five working days from notification, pending instructions. If a reply is not received within five days, the material will be returned to the sender at his expense.
9. Credit on returned parts will be issued at dealer net price at time of the original purchase, less a 15% restocking charge.
10. In cases where an item is accepted, for which the original purchase document can not be determined, the price will be based on the list price that was effective twelve months prior to the RMA date.
11. Credit issued will be applied to future purchases only.

PRICING AND REBATES

Prices are subject to change without prior notice. Price changes are effective on a specific date and all orders received on or after that date will be billed at the revised price. Rebates for price declines and added charges for price increases will not be made for stock on hand at the time of any price change.

Multiquip reserves the right to quote and sell direct to Government agencies, and to Original Equipment Manufacturer accounts who use our products as integral parts of their own products.

SPECIAL EXPEDITING SERVICE

A \$35.00 surcharge will be added to the invoice for special handling including bus shipments, insured parcel post or in cases where Multiquip must personally deliver the parts to the carrier.

LIMITATIONS OF SELLER'S LIABILITY

Multiquip shall not be liable hereunder for damages in excess of the purchase price of the item with respect to which damages are claimed, and in no event shall Multiquip be liable for loss of profit or good will or for any other special, consequential or incidental damages.

LIMITATION OF WARRANTIES

No warranties, express or implied, are made in connection with the sale of parts or trade accessories nor as to any engine not manufactured by Multiquip. Such warranties made in connection with the sale of new, complete units are made exclusively by a statement of warranty packaged with such units, and Multiquip neither assumes nor authorizes any person to assume for it any other obligation or liability whatever in connection with the sale of its products. Apart from such written statement of warranty, there are no warranties, express, implied or statutory, which extend beyond the description of the products on the face hereof.

Effective: February 22, 2006

OPERATION AND PARTS MANUAL

HERE'S HOW TO GET HELP

PLEASE HAVE THE MODEL AND SERIAL
NUMBER ON-HAND WHEN CALLING

UNITED STATES

Multiquip Corporate Office

18910 Wilmington Ave.
Carson, CA 90746
Contact: mq@multiquip.com

Tel. (800) 421-1244
Fax (800) 537-3927

Service Department

800-421-1244
310-537-3700

Fax: 310-537-4259

Technical Assistance

800-478-1244

Fax: 310-943-2238

MQ Parts Department

800-427-1244
310-537-3700

Fax: 800-672-7877
Fax: 310-637-3284

Warranty Department

800-421-1244
310-537-3700

Fax: 310-943-2249

MEXICO

MQ Cipsa

Carr. Fed. Mexico-Puebla KM 126.5
Momoxpan, Cholula, Puebla 72760 Mexico
Contact: pmastretta@cipsa.com.mx

Tel: (52) 222-225-9900
Fax: (52) 222-285-0420

CANADA

Multiquip

4110 Industriel Boul.
Laval, Quebec, Canada H7L 6V3
Contact: jmartin@multiquip.com

Tel: (450) 625-2244
Tel: (877) 963-4411
Fax: (450) 625-8664

UNITED KINGDOM

Multiquip (UK) Limited Head Office

Unit 2, Northpoint Industrial Estate,
Globe Lane,
Dukinfield, Cheshire SK16 4UJ
Contact: sales@multiquip.co.uk

Tel: 0161 339 2223
Fax: 0161 339 3226

© COPYRIGHT 2011, MULTIQUIP INC.

Multiquip Inc and the MQ logo are registered trademarks of Multiquip Inc. and may not be used, reproduced, or altered without written permission. All other trademarks are the property of their respective owners and used with permission.

This manual MUST accompany the equipment at all times. This manual is considered a permanent part of the equipment and should remain with the unit if resold.

The information and specifications included in this publication were in effect at the time of approval for printing. Illustrations, descriptions, references and technical data contained in this manual are for guidance only and may not be considered as binding. Multiquip Inc. reserves the right to discontinue or change specifications, design or the information published in this publication at any time without notice and without incurring any obligations.

Your Local Dealer is:

Manufactured for
Multiquip Inc.
by
DENYO CO., LTD, JAPAN



Free Manuals Download Website

<http://myh66.com>

<http://usermanuals.us>

<http://www.somanuals.com>

<http://www.4manuals.cc>

<http://www.manual-lib.com>

<http://www.404manual.com>

<http://www.luxmanual.com>

<http://aubethermostatmanual.com>

Golf course search by state

<http://golfingnear.com>

Email search by domain

<http://emailbydomain.com>

Auto manuals search

<http://auto.somanuals.com>

TV manuals search

<http://tv.somanuals.com>