

# PARTS AND OPERATION MANUAL

## MQ POWER TLG-12SPX WHISPER WATT™ AC GENERATOR (Standard)

© COPYRIGHT 2001, MULTIQUIP INC.

Revision #4 (03/08/05)

S/N 5107226~



**MULTIQUIP INC.**

18910 WILMINGTON AVE.  
CARSON, CALIFORNIA 90746  
310-537-3700  
800-421-1244  
FAX: 310-537-3927

**PARTS DEPARTMENT:**

800-427-1244  
FAX: 800-672-7877

**SERVICE DEPARTMENT:**

800-835-2551  
FAX: 310-638-8046

E-mail: [mq@multiquip.com](mailto:mq@multiquip.com) • [www.multiquip.com](http://www.multiquip.com)



# **WARNING**



## **CALIFORNIA--Proposition 65 Warning**

**Engine exhaust and some of its constituents are known to the State of California to cause cancer, birth defects and other reproductive harm.**

## **HERE'S HOW TO GET HELP**

*PLEASE HAVE THE MODEL AND SERIAL NUMBER  
ON-HAND WHEN CALLING*

### ***PARTS DEPARTMENT***

*800/427-1244 or 310/537-3700*

*FAX: 800/672-7877 or 310/637-3284*

### ***SERVICE DEPARTMENT***

*800/835-2551 or 310/537-3700*

*FAX: 310/638-8046*

### ***WARRANTY DEPARTMENT***

*800/835-2551 or 310/537-3700*

*FAX: 310/638-8046*

### ***MAIN***

*800/421-1244 or 310/537-3700*

*FAX: 310/537-3927*

Here's How To Get Help .....	3
Table Of Contents .....	4
Parts Ordering Procedures .....	5
Rules for Safe Operation .....	6-9
Towing and Transportation .....	10
Trailer Safety Guidelines .....	11-15
Trailer Wiring Diagram .....	16
Operation and Safety Decals .....	17-18
TLG-12SPX Specifications .....	19

## MQ POWER TLG-12SPX AC GENERATOR

General Information .....	20
Major Components .....	21
Dimensions .....	22
Control Panel Descriptions .....	24-25
Engine Operating/ Output Terminal Panel Descriptions .....	26-27
Output Terminal Information .....	28-29
Installation .....	30-31
Pre Setup .....	32-35
Load Application .....	36
Generator Start-up Procedure .....	37
Generator Shutdown Procedure .....	38
Maintenance .....	40-41
Engine Wiring Diagram .....	42
Generator Wiring Diagram .....	43
Engine Troubleshooting .....	44-45
Generator/Engine Troubleshooting .....	46
Explanation of Codes in Remarks Column .....	48
Suggested Spare Parts .....	49
Generator Assembly .....	50-51
Control Panel Assembly .....	52-55
Engine & Radiator Assembly .....	56-57
Battery Assembly .....	58-59
Muffler Assembly .....	60-61
Fuel Tank Assembly .....	62-63
Enclosure Assembly .....	64-67
Rubber Seal Assembly .....	68-69
Name Plate And Decals .....	70-71

## ISUZU 3LB1 ENGINE

Cylinder Head Cover Assembly .....	72-73
Cylinder Head Assembly .....	74-75
Cylinder Block Assembly .....	76-77
Oil Pan & Level Gauge Assembly .....	78-79
Camshaft & Valve Assembly .....	80-81
Crankshaft Piston & Flywheel Assembly .....	82-83
Timing Gear & Flywheel Housing Assembly .....	84-85
Inlet Manifold Assembly .....	86-87
Exhaust Manifold Assembly .....	88-89
Ventilation Assembly .....	90-91
Water Pump & Corrosion Resistor Assembly .....	92-93
Thermostat and Housing Assembly .....	94-95
Fan & Fan Belt Assembly .....	96-97
Fuel Injection Assembly .....	98-99
Fuel Filter & Bracket Assembly .....	100-101
Fuel Pump & Pipe Assembly .....	102-103
Oil Cooler & Oil Filter Assembly .....	104-105
Oil Pump & Oil Strainer Assembly .....	106-107
Electrical Control Assembly .....	108-109
Starter Comp. Assembly .....	110-111
Injection Pump Comp. Assembly .....	112-115
Timing Chain X Case Assembly .....	116-119
Air Cleaner Assembly .....	120-121
Switch and Relay Assembly .....	122-123
Terms and Condition of Sale — Parts .....	124

### NOTE

*Specification and part number  
are subject to change without  
notice.*

- Dealer account number
- Dealer name and address
- Shipping address (if different than billing address)
- Return fax number
- Applicable model number
- Quantity, part number and description of each part
- Specify preferred method of shipment:
  - UPS Ground
  - UPS Second Day or Third Day\*
  - UPS Next Day\*
  - Federal Express Priority One (please provide us with your Federal Express account number)\*
  - Airborne Express\*
  - Truck or parcel post

*\*Normally shipped the same day the order is received, if prior to 2PM west coast time.*

## Earn Extra Discounts when you order by FAX!

All parts orders which include complete part numbers and are received by fax qualify for the following extra discounts:

<u>Number of line items ordered</u>	<u>Additional Discount</u>
1-9 items	3%
10+ items**	5%

### Get special freight allowances when you order 10 or more line items via FAX! \*\*

- UPS Ground Service at no charge for freight
- PS Third Day Service at one-half of actual freight cost

No other allowances on freight shipped by any other carrier.

\*\*Common nuts, bolts and washers (all items under \$1.00 list price) do not count towards the 10+ line items.

\*DISCOUNTS ARE SUBJECT TO CHANGE\*

Fax order discount and UPS special programs revised June 1, 1995

**Extra Fax Discount  
for Domestic USA  
Dealers Only**

**Up to 5%  
extra savings!**

**UPS  
Special**  
For faxed orders only

**Now! Direct TOLL-FREE access  
to our Parts Department!**

Toll-free nationwide:

**800-421-1244**

Toll-free FAX:

**800/6-PARTS-7 • 800-672-7877**

## CAUTION:



Failure to follow instructions in this manual may lead to serious injury or even death! This equipment is to be operated by trained and qualified personnel only! This equipment is for industrial use only.

The following safety guidelines should always be used when operating the TLG-12SPX portable generator:

### GENERAL SAFETY

- **DO NOT** operate or service this equipment before reading this entire manual.



- This equipment should not be operated by persons under 18 years of age.



- **NEVER** operate this equipment without proper protective clothing, shatterproof glasses, steel-toed boots and other protective devices required by the job.

- **NEVER** operate this equipment when not feeling well due to fatigue, illness or taking medicine.



- **NEVER** operate this equipment under the influence of drugs or alcohol.



- **NEVER** use accessories or attachments, which are not recommended by MQ Power for this equipment. Damage to the equipment and/or injury to user may result.

- Manufacturer does not assume responsibility for any accident due to equipment modifications.

- Whenever necessary, replace nameplate, operation and safety decals when they become difficult read.

- Always check the machine for loosened threads or bolts before starting.

- Be sure the generator is on secure level ground so that it cannot slide or shift around, endangering workers. Also keep the immediate area free of all bystanders.

- **NEVER** touch the hot exhaust manifold, muffler or cylinder. Allow these parts to cool before servicing engine or generator.



- **High Temperatures** – Allow the engine to cool before adding fuel or performing service and maintenance functions. Contact with *hot* components can cause serious burns.

- The engine of this generator requires an adequate free flow of cooling air. Never operate the generator in any enclosed or narrow area where free flow of the air is restricted. If the air flow is restricted it will cause serious damage to the generator or engine and may cause injury to people. The generator engine gives off **DEADLY** carbon monoxide gas.

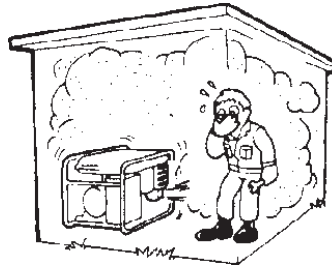

## CAUTION:



Always refuel in a well-ventilated area, away from sparks and open flames.

- Always use extreme caution when working with **flammable** liquids. When refueling, **stop the engine** and allow it to cool. **DO NOT** smoke around or near the machine. Fire or explosion could result from fuel vapors, or if fuel is spilled on a hot engine.



- **NEVER** operate the generator in an explosive atmosphere or near combustible materials. An explosion or fire could result causing severe *bodily harm or even death*.

- Topping-off to filler port is dangerous, as it tends to spill fuel.

## CAUTION:

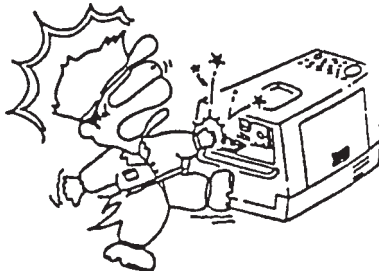

■ **NEVER** touch output terminals during operation. This is extremely dangerous. Always stop the machine when contact with the output terminals is required.

## CAUTION:

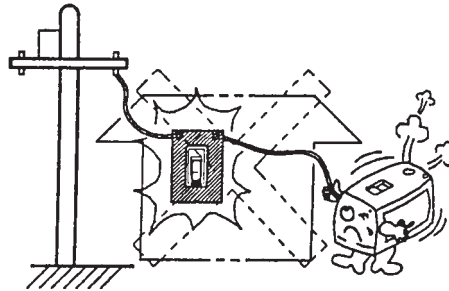

■ **Backfeed** to a utility system can cause electrocution and/or property damage. Do not connect to any building's electrical system except through an approved device or after building main switch is opened.

## CAUTION:



■ **Never** use damaged or worn cables when connecting power tools or equipment to the generator. Make sure power connecting cables are securely connected to the generator's output terminals, insufficient tightening of the terminal connections may cause damage to the generator and electrical shock.

## CAUTION:

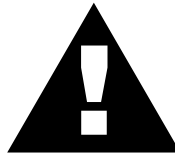

**DO NOT** touch or open any of the below mentioned components while the generator is running. Always allow sufficient time for the engine and generator to cool before performing maintenance.

### Radiator

1. **Radiator Cap** - Removing the radiator cap while the engine is hot will result in high pressurized, boiling water to gush out of the radiator, causing severe scalding to any persons in the general area of the generator.

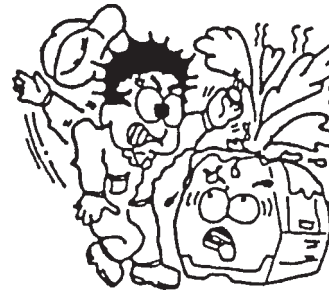

2. **Coolant Drain Plug** - Removing the coolant drain plug while the engine is hot will result in hot coolant to gush out of the coolant drain plug, therefore causing severe scalding to any persons in the general area of the generator.
3. **Engine Oil Drain Plug** - Removing the engine oil drain plug while the engine is hot will result in hot oil to gush out of the oil drain plug, therefore causing severe scalding to any persons in the general area of the generator.



## Battery

### CAUTION:



Never over fill the battery with water above the upper limit.

The battery contains acids that can cause injury to the eyes and skin. To avoid eye irritation, always wear safety glasses. Use well insulated gloves when picking up the battery. Use the following guidelines when handling the battery:

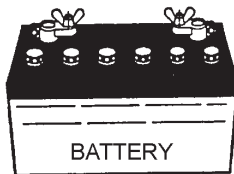

1. **DO NOT** drop the battery. There is the possibility of risk that the battery may explode.
  2. **DO NOT** expose the battery to open flames, sparks, cigarettes etc. The battery contains combustible gases and liquids. If these gases and liquids come in contact with a flame or spark, an explosion could occur.
  3. Always keep the battery charged. If the battery is not charged a buildup of combustible gas will occur.
  4. Always keep battery charging and booster cables in good working condition. Repair or replace all worn cables.
  5. Always recharge the battery in an open air environment, to avoid risk of a dangerous concentration of combustible gases.
  6. In case the battery liquid (dilute sulfuric acid) comes in contact with **clothing or skin**, rinse skin or clothing immediately with plenty of water.
  7. In case the battery liquid (dilute sulfuric acid) comes in contact with your **eyes**, rinse eyes immediately with plenty of water, then contact the nearest doctor or hospital, and seek medical attention.
- **NEVER** Run engine without air filter. Severe engine damage may occur.
  - Always service air cleaner frequently to prevent carburetor malfunction.
  - Always disconnect the battery before performing service on the generator.
  - Always be sure the operator is familiar with proper safety precautions and operations techniques before using generator.
  - Always store equipment properly when not in use. Equipment should be stored in a clean, dry location out of the reach of children.
  - **DO NOT** leave the generator running in the manual mode unattended.
  - **DO NOT** allow unauthorized people to operate this equipment.
  - Always read, understand, and follow procedures in Operator's Manual before attempting to operate equipment.
  - Refer to the *Isuzu Engine Operator's Manual* for engine technical questions or information.

### Loading and Unloading (Crane)

- Before lifting, make sure the generator's lifting hook is secure and that there is no apparent damage to the generator itself (loose screws, nuts and bolts). If any part is loose or damaged, please take corrective action before lifting.
- Always drain fuel prior to lifting.
- Always make sure crane or lifting device has been properly secured to the hook of guard frame on generator.
- **NEVER** lift the machine while the engine is running.
- Use adequate lifting cable (wire or rope) of sufficient strength.
- When lifting the generator, always use the balanced center-point suspension hook and lift straight upwards.
- **NEVER** allow any person or animal to stand underneath the machine while lifting.
- When loading the generator on a truck, be sure to use the front and back frame bars as a means to secure the generator during transport.



## Transporting

- Always shutdown engine before transporting.
- Tighten fuel tank cap securely.
- Drain fuel when transporting generator over long distances or bad roads.
- Always tie-down the generator during transportation by securing the generator.
- If generator is mounted on a trailer, make sure trailer complies with all local and state safety transportation laws. See page 10 for basic towing procedures.

## Emergencies

- Always know the location of the nearest **fire extinguisher** and **first aid kit**. Know the location of the nearest telephone. Also know the phone numbers of the nearest **ambulance**, **doctor** and **fire department**.

## Maintenance Safety

- **NEVER** lubricate components or attempt service on a running machine.
- Always allow the machine a proper amount of time to cool before servicing.
- Keep the machinery in proper running condition.
- Fix damage to the machine immediately and always replace broken parts.
- Dispose of hazardous waste properly. Examples of potentially hazardous waste are used motor oil, coolant, fuel, and fuel filters.
- **DO NOT** use plastic containers to dispose of hazardous waste.
- **DO NOT** pour waste, oil, coolant or fuel directly onto the ground, down a drain or into any water source.

# TLG-12SPX — TOWING RULES FOR SAFE OPERATION

## Towing Safety Precautions

### CAUTION :



Check with your county or state safety towing regulations department before towing your generator.

To reduce the possibility of an accident while transporting the generator on public roads, always make sure the trailer (Figure 1) that supports the generator and the towing vehicle are in good operating condition and both units are mechanically sound.

The following list of suggestions should be used when towing your generator:

- Make sure the hitch and coupling of the towing vehicle are rated equal to, or greater than the trailer "gross vehicle weight rating" (GVWR).
- **ALWAYS** inspect the hitch and coupling for wear. **NEVER** tow a trailer with defective hitches, couplings, chains etc.
- Check the tire air pressure on both towing vehicle and trailer. Also check the tire tread wear on both vehicles.
- **ALWAYS** make sure the trailer is equipped with a "Safety Chain".
- **ALWAYS** attach trailer's safety chain to bumper of towing vehicle.
- **ALWAYS** make sure the vehicle and trailer directional, backup, brake, and trailer lights are connected and working properly.
- The maximum speed for highway towing is **45 MPH** unless posted otherwise. Recommended off-road towing is not to exceed **10 MPH** or less depending on type of terrain.
- Place *chocked blocks* underneath wheel to prevent **rolling**, while parked.
- Place *support blocks* underneath the trailer's bumper to prevent **tipping**, while parked.
- Use the trailer's hand winch to adjust the height of the trailer, then insert locking pin to lock wheel stand in place, while parked.
- Avoid sudden stops and starts. This can cause skidding, or jackknifing. Smooth, gradual starts and stops will improve gas mileage.
- Avoid sharp turns to prevent rolling.
- Remove wheel stand when transporting.
- **DO NOT** transport generator with fuel in tank.

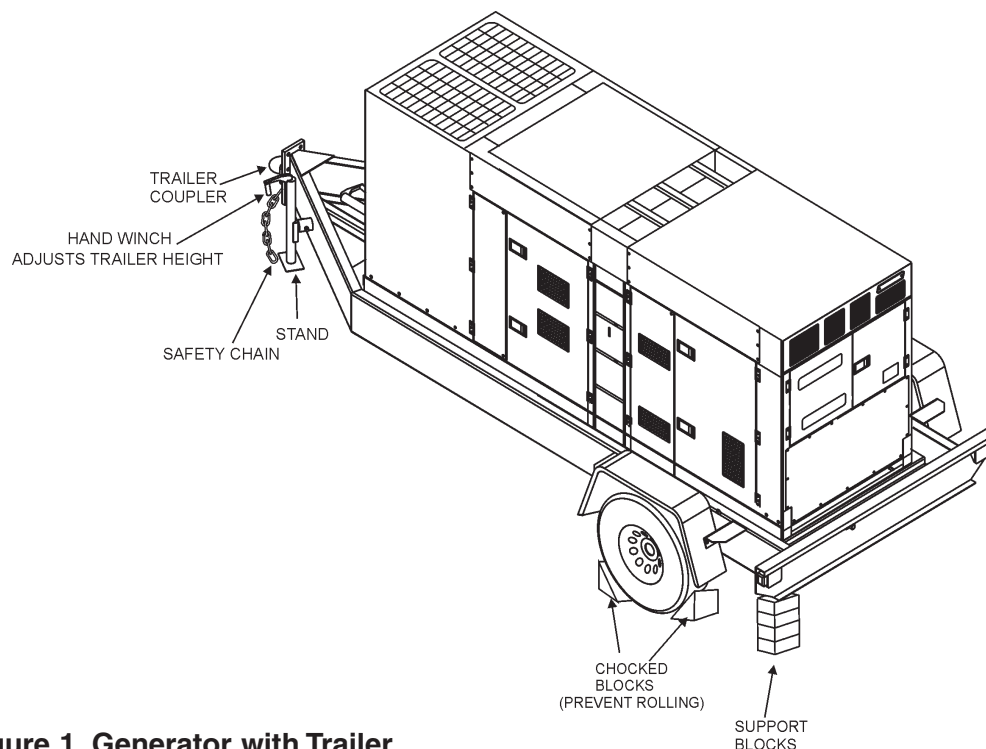

Figure 1. Generator with Trailer

## CAUTION:



**ALWAYS** make sure the trailer is in good operating condition. Check the tires for proper inflation and wear. Also check the wheel lug nuts for proper tightness.

### Explanation of Chart:

This section is intended to provide the user with trailer service and maintenance information. The service and maintenance guidelines referenced in this section apply a wide range of trailers. Remember periodic inspection of the trailer will ensure safe towing of the equipment and will prevent damage to the equipment and personal injury.

It is the purpose of this section to cover the major maintenance components of the trailer. The following trailer components will be discussed in this section:

- Brakes
- Tires
- Lug Nut Torquing
- Suspension
- Electrical
- Brake Troubleshooting Tables

Use the following definitions with reading Table 1.

1. **Fuel Cell** - Provides an adequate amount of fuel for the equipment in use. Fuel cells must be empty when transporting equipment.
2. **Braking System** - System employed in stopping the trailer. Typical braking systems are electric, surge, hydraulic, hydraulic-surge and air.
3. **GVWR**- Gross Vehicle Weight Rating (GVWR), is the maximum number of pounds the trailer can carry, including the fuel cell (empty).
4. **Frame Length** - This measurement is from the ball hitch to the rear bumper (reflector).
5. **Frame Width** - This measurement is from fender to fender.
6. **Jack Stand** - Trailer support device with maximum pound requirement from the tongue of the trailer.
7. **Coupler** - Type of hitch used on the trailer for towing.
8. **Tire Size** - Indicates the diameter of the tire in inches (10,12,14, etc.), and the width in millimeters (175,185,205, etc.). The tire diameter must match the diameter of the tire rim.
9. **Tire Ply** - The tire ply (layers) number is rated in letters; 2-ply,4-ply,6-ply, etc.
10. **Wheel Hub** - The wheel hub is connected to the trailer's axle.
11. **Tire Rim** - Tires mounted on a tire rim. The tire rim must match the size of the tire.
12. **Lug Nuts** - Used to secure the wheel to the wheel hub. Always use a torque wrench to tighten down the lug nuts. See Table 4 and Figure 5 or lug nut tightening and sequence.
13. **Axle** - Indicates the maximum weight the axle can support in pounds, and the diameter of the axle expressed in inches (see Table 3). Please note that some trailers have a double axle. This will be shown as 2-6000 lbs., meaning two axles with a total weight capacity of 6000 pounds.
14. **Suspension** - Protects the trailer chassis from shocks transmitted through the wheels. Types of suspension used are leaf, Q-flex, and air ride.
15. **Electrical** - Electrical connectors (looms) are provided with the trailer so the brake lights and turn signals can be connected to the towing vehicle.
16. **Application** - Indicates which units can be employed on a particular trailer.

# TLG-12SPX —TRAILER-SPECIFICATIONS

Table 1. Specifications

MODEL	APPLICATION	FUEL CELL	BRAKE SYSTEM	GVWR	FRAME LENGTH	FRAME WIDTH	JACK STAND
TRLR-10W	SDW225, SGW250,TLW300	NO	NO	1900LBS	96"	50"	800LB. FULL TILT WHEEL
TRLR-10	DCA10, TLG12, DCA-15	NO	NO	1900LBS	96"	50"	800LB. FULL TILT WHEEL
TRLR-10XF	DCA10, TLG-12, DCA15, TLW-300	52 GAL	NO	1900LBS	96"	50"	800LB. FULL TILT WHEEL
TRLR-225W	WELDERS, DA7000SS	NO	NO	2200LBS	85"	42"	800LB. FULL TILT WHEEL
TRLR-BLW400	BLW-400	NO	ELECTRIC	2700LBS	W/MAST 154" W/O 124"	55" (78" TALL)	800LB. FULL TILT WHEEL
TRLR-50X	DCA-25	NO	NO	2700LBS	124"	55"	800LB. FULL TILT WHEEL
TRLR-50XF	DCA-25	41 GAL	NO	2700LBS	124"	55"	800LB. FULL TILT WHEEL
TRLR-70W	DCA-45, -60, 70	NO	SURGE	7000LBS	186"	77"	2000LB. FLAT PAD
TRLR-70X	DCA-45, -60, 70	OPT	SURGE	7000LBS	138"	66"	2000LB. FLAT PAD
TRLR-70XF	DCA-45, -60, 70	53 GAL	SURGE	7000LBS	138"	66"	2000LB. FLAT PAD
TRLR-100XF	DCA-100, 125	150 GAL	HYDRAULIC SURGE	7000LBS	190"	76"	2000LB. FLAT PAD
TRLR-85/125	DCA-85, 100, 125	145 GAL	HYDRAULIC	10000LBS	186"	77"	2000LB. FLAT PAD
TRLR-150XF	DCA-150, 180	200 GAL	HYDRAULIC SURGE	11160LBS	204"	84"	5000 LB. FLAT PAD
TRLR-220XF	DCA-220	250 GAL	HYDRAULIC SURGE	14000LBS	222"	83"	5000 LB. FLAT PAD
TRLR-300XF	DCA-300	250 GAL	HYDRAULIC SURGE	18000LBS	238"	83"	5000 LB. FLAT PAD
TRLR-400XF	DCA-400	350 GAL	ELECTRIC	18000LBS	238"	83"	5000 LB. FLAT PAD
TRLR-600XF	DCA-600, 800	550 GAL	AIR	30000LBS	384"	96"	5000 LB. FLAT PAD
TRLR-800SX	DCA-600, 800	550 GAL	AIR	30000LBS	384"	96"	5000 LB. FLAT PAD

# TLG-12SPX —TRAILER-SPECIFICATIONS

Table 1. Specifications (Con't)

MODEL	COUPLER	TIRES	WHEELS	AXLE	HUBS	SUSPENSION	ELECTRICAL
TRLR-10W	2" BALL CLASS 2 ADJUSTABLE	175-13C	13"X4.50"	2200# 2X2	5 LUG	3 LEAF	4 WIRE LOOM W/ 4 POLE FLAT
TRLR-10	2" BALL CLASS 2 ADJUSTABLE	175-13C	13"X4.5"	2200#2X2	5 LUG	3 LEAF	4 POLE FLAT
TRLR-10XF	2" BALL CLASS 2 ADJUSTABLE	175-13C	13"X4.5"	2200#2X2	5 LUG	3 LEAF	4 POLE FLAT
TRLR-225W	2" BALL CLASS 2 ADJUSTABLE	175-13B	13X4.5"	2200#2X2	5 LUG	Q FLEX	4 POLE FLAT
TRLR-BLW 400	2" BALL CLASS 2 ADJUSTABLE	175-13C	13 X 4.5"	2200#2X2	5 LUG	3 LEAF	4 POLE FLAT
TRLR-50X	2" BALL CLASS	B78-13LRC	13"X4.50"	3500lbs. 2-3/8"	5 LUG	4 LEAF	4 POLE RUBBER FLAT
TRLR-50XF	2" BALL CLASS	B78-13LRC	13"X4.50"	3500lbs. 2-3/8"	5 LUG	4 LEAF	4 POLE RUBBER FLAT
TRLR-70W	2" BALL CLASS 3" ADJUSTABLE	205-14C BIAS (4)	14"X5"	3500lbs. 3"	5 LUG	5 LEAF	4 POLE RUBBER FLAT
TRLR-70X	2" BALL CLASS 3" ADJUSTABLE	205-14C BIAS (4)	14"X5"	3500lbs 3"	5 LUG	5 LEAF	4 POLE RUBBER FLAT
TRLR-70XF	2" BALL CLASS 3" ADJUSTABLE	205-14C BIAS (4)	14"X5"	3500lbs. 3"	5 LUG	5 LEAF	4 POLE RUBBER FLAT
TRLR-100XF	ADJUSTABLE 2-5/6 OPT 3" EYE	205-15C BIAS (4)	14"X5.5"	3500lbs 3"	5 LUG	5 LEAF	4 WIRE LOOM
TRLR-85/125	ADJUSTABLE 2-5/6 OPT 3" EYE	ST225/75R15D RADIAL (4)	14"x6"	(2)-6000lbs	6 LUG	7 LEAF	4 WIRE LOOM
TRLR-150XF	3" BALL EYE	750-16 E BIAS (4)	16"X7"	(2)-6000lbs	8 LUG	7 LEAF	4 WIRE LOOM
TRLR-220XF	3" EYE ADJUSTABLE	ST235/85R16E RADIAL(4)	16"X7"	(2)-7000lbs	8 LUG	Q FLEX	4 WIRE LOOM
TRLR-300XF	3" EYE ADJUSTABLE	ST235/85R16E RADIAL(6)	16"X7"	(2)-6000lbs	8 LUG	Q FLEX	4 WIRE LOOM
TRLR-400XF	3" EYE ADJUSTABLE	ST235/85R16E RADIAL(6)	16"X7"	(3)-7000lbs.	8 LUG	Q FLEX	4 WIRE LOOM
TRLR-600XF	5TH WHEEL	ST215/75R17.5H RADIAL (8)	16"X7"	(3)-10000lbs	8 LUG	7 LEAF	6 WIRE LOOM
TRLR-800AR	5TH WHEEL	ST215/75R17.5H RADIAL (8)	16"X7"	(3)-10000lbs	8 LUG	AIR-RIDE	6 WIRE LOOM

## Tires/Wheels/Lug Nuts

Tires and wheels are a very important and critical components of the trailer. When specifying or replacing the trailer wheels it is important the wheels, tires, and axle are properly matched.

### CAUTION:



DO NOT attempt to repair or modify a wheel. DO NOT install in inner tube to correct a leak through the rim. If the rim is cracked, the air pressure in the inner tube may cause pieces of the rim to explode (break off) with great force and cause serious eye or bodily injury.

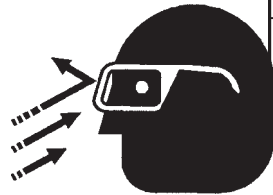

### Tire Wear/Inflation

Tire inflation pressure is the most important factor in tire life. Pressure should be checked cold before operation DO NOT bleed air from tires when they are hot. Check inflation pressure weekly during use to insure the maximum tire life and tread wear.

Table 2 (Tire Wear Troubleshooting) will help pinpoint the causes and solutions of tire wear problems.

### CAUTION:

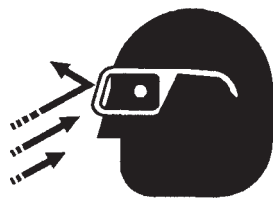

#### NOTE

ALWAYS wear safety glasses when removing or installing force fitted parts. Failure to comply may result in serious injury.

TABLE 2. TIRE WEAR TROUBLESHOOTING

WEAR PATTERN		CAUSE	SOLUTION
	Center Wear	Over Inflation.	Adjust pressure to particular load per tire manufacturer.
	Edge Wear	Under Inflation.	Adjust pressure to particular load per tire manufacturer.
	Side Wear	Loss of camber or overloading.	Make sure load does not exceed axle rating. Align wheels.
	Toe Wear	Incorrect toe-in.	Align wheels.
	Cupping	Out-of-balance.	Check bearing adjustment and balance tires.
	Flat Spots	Wheel lockup & tire skidding.	Avoid sudden stops when possible and adjust brakes.

## Suspension

The leaf suspension springs and associated components (Figure 2) should be visually inspected every 6,000 miles for signs of excessive wear, elongation of bolt holes, and loosening of fasteners. Replace all damaged parts (suspension) immediately. Torqued suspension components as detailed in Table 3.

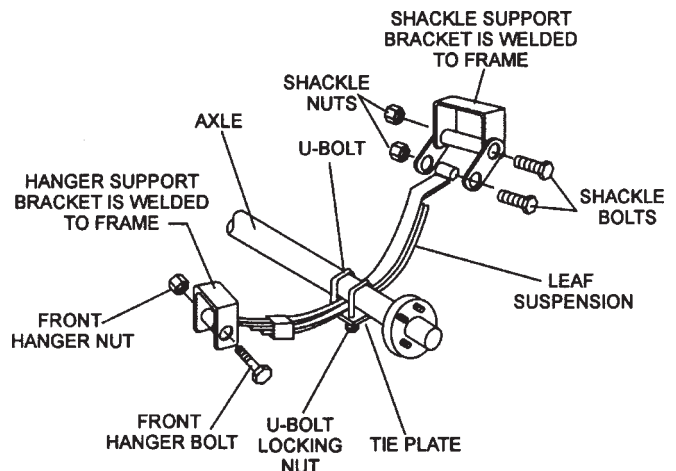

Figure 2. Major Suspension Components

**Table 3. Suspension Torque Requirements**

Item	Torque (Ft.-Lbs.)
3/8" U-BOLT	MIN-30 MAX-35
7/16" U-BOLT	MIN-45 MAX-60
1/2" U-BOLT	MIN-45 MAX-60
SHACKLE BOLT SPRING EYE BOLT	SNUG FIT ONLY. PARTS MUST ROTATE FREELY. LOCKING NUTS OR COTTER PINS ARE PROVIDED TO RETAIN NUT-BOLT ASSEMBLY.
SHOULDER TYPE SHACKLE BOLT	MIN-30 MAX-50

### Lug Nut Torque Requirements

It is extremely important to apply and maintain proper wheel mounting torque on the trailer. Be sure to use only the fasteners matched to the cone angle of the wheel. Proper procedure for attachment of the wheels is as follows:

1. Start all wheel lug nuts by hand.
2. Torque all lug nuts in sequence. See Figure 3. **DO NOT** torque the wheel lug nuts all the way down. Tighten each lug nut in 3 separate passes as defined by Table 4.
3. After first road use, retorque all lug nuts in sequence. Check all wheel lug nuts periodically.

**Table 4. Tire Torque Requirements**

Wheel Size	First Pass FT-LBS	Second Pass FT-LBS	Third Pass FT-LBS
12"	20-25	35-40	50-65
13"	20-25	35-40	50-65
14"	20-25	50-60	90-120
15"	20-25	50-60	90-120
16"	20-25	50-60	90-120

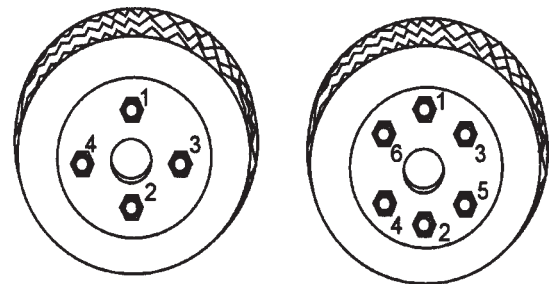

4-LUG NUTS

6-LUG NUTS

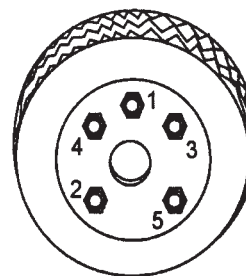

5-LUG NUTS

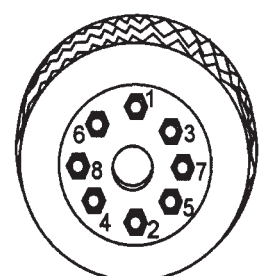

8-LUG NUTS

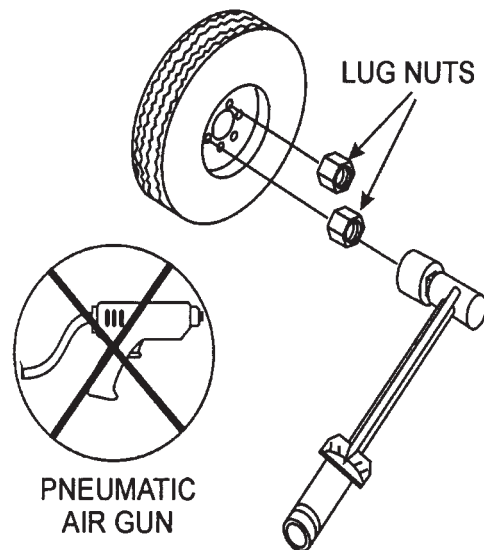

**Figure 3. Wheel Lug Nuts Tightening Sequence**

**NOTE**

NEVER use an pneumatic air gun to tighten wheel lug nuts.



# TLG-12SPX —TRAILER WIRING DIAGRAM

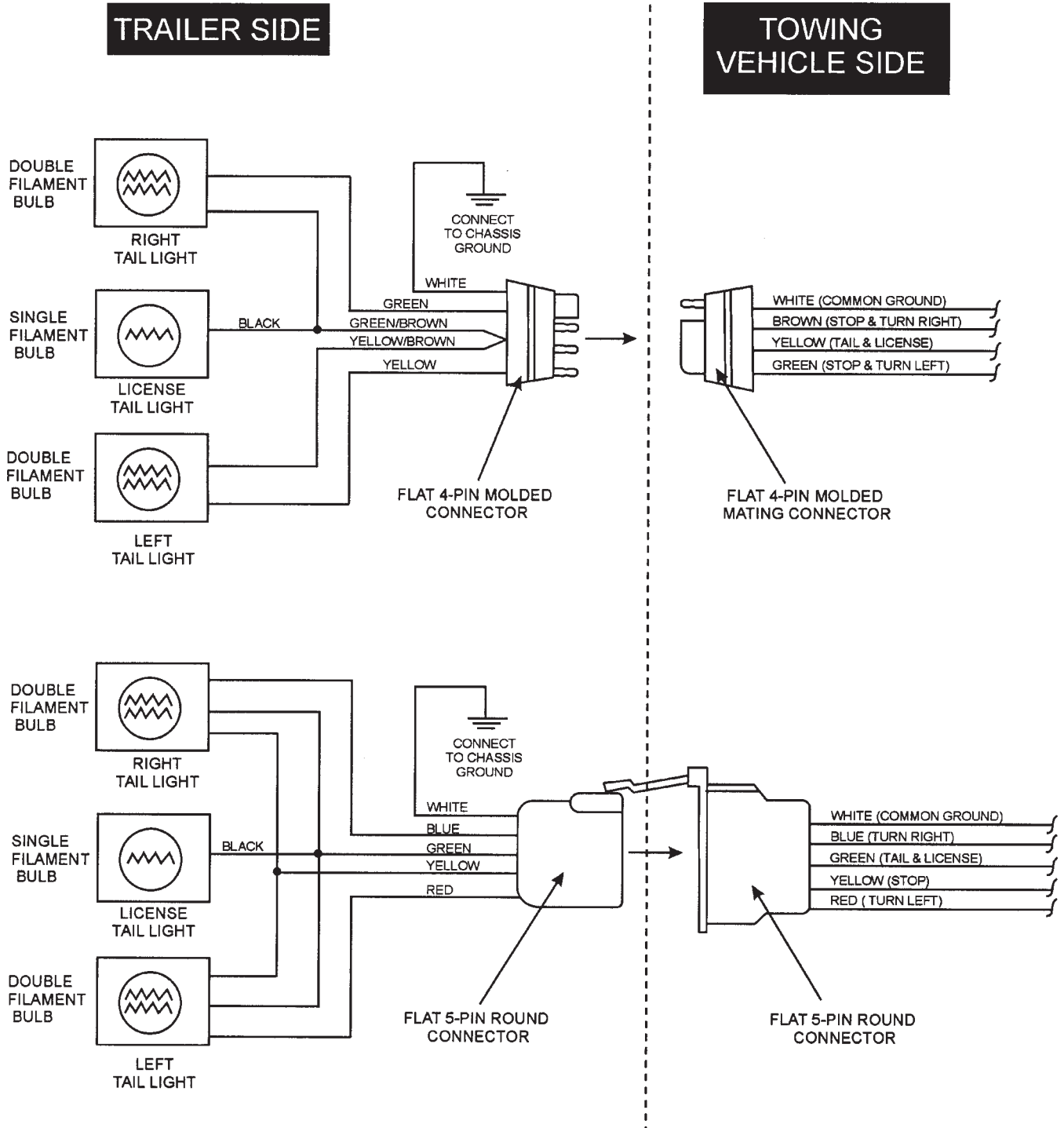

**NOTE:**  
LIGHTS ARE ORIENTED FROM THE DRIVER'S SEAT

The TLG-12SPX generator is equipped with a number of safety decals. These decals are provided for operator safety and maintenance information. The illustration below and on the preceding pages show the decals as they appear on the machine. Should any of these decals become unreadable, replacements can be obtained from your dealer.

**IMPORTANT "CHECK DAILY"**

<p>1. Radiator water level.</p> <p>2. Reserve tank water level.</p> <p>(Important) Not more than a 50/50 Anti-Freeze/Water Mixture is recommended.</p> <p>3. Engine Oil Level.</p>	<p>1.</p> <p>2.</p> <p>3.</p> <p>HIGH LOW</p> <p>S-2377</p>
--	---

P/N 63906 71104

**SAFETY INSTRUCTIONS**

Improper operation of this machine can cause severe injury or death.

- Read the instruction manual carefully before operating or servicing.

This machine should only be operated by a person with sufficient knowledge and skill to ensure safe operation.

High voltage circuits are located inside the output terminal cover and control panel.

- Close the cover and control panel before operating.

Moving parts and hot surfaces are contained within the enclosure.

- Close all doors and lock them before operating.

**GROUND**  
For G.F.C.I.  
S-3821

P/N 76706 24004

**WATER**  
S-1880

P/N 63606 10304

P/N S-4753

**Denyo**  
**MQ**  
**POWER**

**CIRCUIT BREAKER**  
S-3031

**DIESEL FUEL**

DECREASE INCREASE  
VOLTAGE REGULATOR  
S-3737

**SUPPORT HOOK**

Never use it for lifting the unit.  
Use the LIFT HOOK on the roof for lifting.

S-2257

P/N 13206 21504

# TLG-12SPX — GENERATOR DECALS



**⚠ WARNING**

- Before connecting this generator to any building's electrical system, a licensed electrician must install an isolation (transfer) switch.
- Serious injury or death may result without this transfer switch.

P/N M9520100004



P/N 08040619904

**DANGER EXPLOSIVE GASES**  
Cigarettes, flames or sparks could cause battery to explode. Always shield eyes and face from battery. Do not charge or use booster cables or adjust post connections without proper instruction and training.  
**KEEP VENT CAPS TIGHT AND LEVEL**  
**POISON CAUSES SEVERE BURNS**  
Contains sulfuric acid. Avoid contact with skin, eyes or clothing. In event of accident flush with water and call a physician immediately.  
**KEEP OUT OF REACH OF CHILDREN**

P/N 08206 50604



**⚠ WARNING**

**ELECTRIC SHOCK HAZARD**

- Always complete the grounding path from the ground terminal on this genset to an external grounding source. See instruction manual for details.

P/N B93110050



**⚠ WARNING**

**HOT COOLANT can cause severe burns.**

- Do not remove cap if radiator is hot.

P/N B9504100104



**⚠ WARNING**

**ENGINE EXHAUST can cause severe injury or death.**

- Use only in open, well ventilated areas or vent exhaust outside.

P/N B950420004

**SUPPORT HOOK**

Never use it for lifting the unit.  
Use the LIFT HOOK on the roof for lifting.

S-2257

P/N 1320621504



**⚠ CAUTION**

**MOVING PARTS can cause severe injury.**

- Do not operate with doors open.
- Stop engine before servicing.

P/N M9503000004



**⚠ WARNING**

**HOT PARTS can burn skin.**

- Do not touch until the machine has sufficiently cooled.

P/N M9510100004



**⚠ WARNING**

**ELECTRIC SHOCK HAZARD**

- Do not touch internal wiring or connections while this machine is operating.
- Turn power off before servicing.

M92010000

P/N M9520100004

Table 5. Specifications		
Generator Specifications		
Model	TLG-12SPX	
Type	Revolving field, self ventilated, drip proof, single bearing generator	
Armature Connection	Series	
Standby Output	13KW	
Prime Output	12KW	
Voltage	240V or 480V	
Frequency	60 Hz	
Speed	3600 rpm	
Power Factor	1	
Aux. AC Power	Single Phase, 60 Hz	
Voltage	120/240 V	
Sound level dB(A) Full load 23 feet	67	
Engine Specifications		
Model	Isuzu 3LB1	
Type	4 Cycle, water-cooled,swirl chamber	
No. of Cylinders	3 cylinders	
Bore x Stroke	3.0 in. x 3.1 in. (77mm x 80mm)	
Rated Output	22HP/3600 rpm	
Displacement	68 cu. in. (1124 cc)	
Starting	Electric	
Coolant Capacity	0.9gal. (3.4 liters)	
Lube Oil Capacity	1.2 gal. (4.5 liters)	
Fuel Consumption	1.4 gal. (5.3L)/hr at <b>full load</b>	1.2 gal. (4.5L)/hr at <b>3/4 load</b>
	1.0 gal. (3.7L)/hr at <b>1/2 load</b>	0.8 gal. (3.0L)/hr at <b>1/4 load</b>
Battery	12V- 70Ah x 1	
Fuel	#2 Diesel Fuel	

## TLG-12SPX FAMILIARIZATION

### Generator

The MQ Power Model TLG-12SPX is a 9.6 kW **generator** that is designed as a high quality portable power source for telecom sites, lighting facilities, power tools, submersible pumps and other industrial and construction machinery.

### Control Panel

The "Control Panel" is provided with the following:

- Engine Speed Switch
- Indicator panel
- Output Voltage Adjustment Knob
- Frequency Meter (Hz)
- AC Ammeter (Amps)
- AC Voltmeter (Volts)
- Main Circuit Breaker 50 amps

### Output Terminal Panel

The "Output Terminal Panel" is provided with the following:

- One 120/240V output receptacle, 50 amp
- Two 120V input receptacles, 20 amp and 30 amp
- One 240V input receptacle, 30amp

### Open Delta Excitation System

The TLG-12SPX generator is equipped with the state of the art "**Open-Delta**" excitation system. The open delta system consist of an electrically independent winding wound among stationary windings of the AC output section.

There are four leads: A, B, C and D. During light loads, the power to the **Automatic Voltage Regulator (AVR)** is supplied from the leads parallel connections of B&C. When loads increase, the AVR switches and accepts power from leads A&D. The output of leads A&D increase proportionally with load. This of adding the voltages to each phase provides better voltage response during heavy loads.

The connections of the AVR to the AC output windings are for sensing only. No power is required from these windings.

The open-delta design provides virtually unlimited excitation current, offering maximum motor starting capabilities. The excitation does not have a "**fixed ceiling**" and responds according the demands of the required load.

### Engine

The **TLG-12SPX** is powered by a 4 cycle, water cooled, Isuzu 3LB1 **diesel** engine. This engine is designed to meet every performance requirement for the generator. Reference Table 5, page 19 for engine specifications.

In keeping with Multiquip's policy of constantly improving its products, the specifications quoted herein are subject to change without prior notice.

The basic controls and indicators for the TLG-12SPX generator are addressed on the following pages.

### Mechanical Governor System

The mechanical governor system control the RPM of the engine. When the engine demands increase or decrease, the mechanical governor system regulates the frequency variation to  $\pm 1.5\%$ . The electronic governor option increases frequency variation to  $\pm .25\%$ .

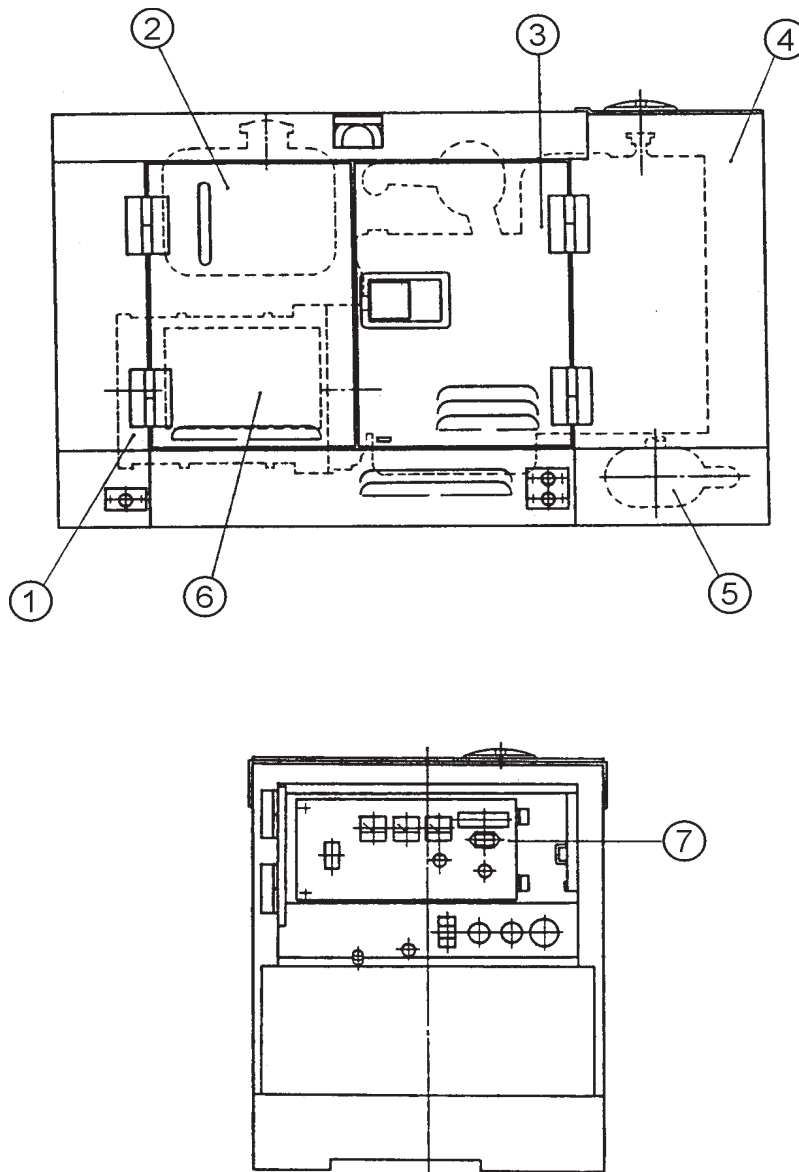

NO	DESCRIPTION
1	GENERATOR ASSY.
2	FUEL TANK ASSY.
3	ENGINE AND RADIATOR ASSY.
4	ENCLOSURE ASSY.
5	MUFFLER ASSY.
6	BATTERY ASSY.
7	CONTROL PANEL ASSY.

Figure 4. Major Components

# TLG-12SPX — DIMENSIONS (TOP, SIDE AND FRONT)

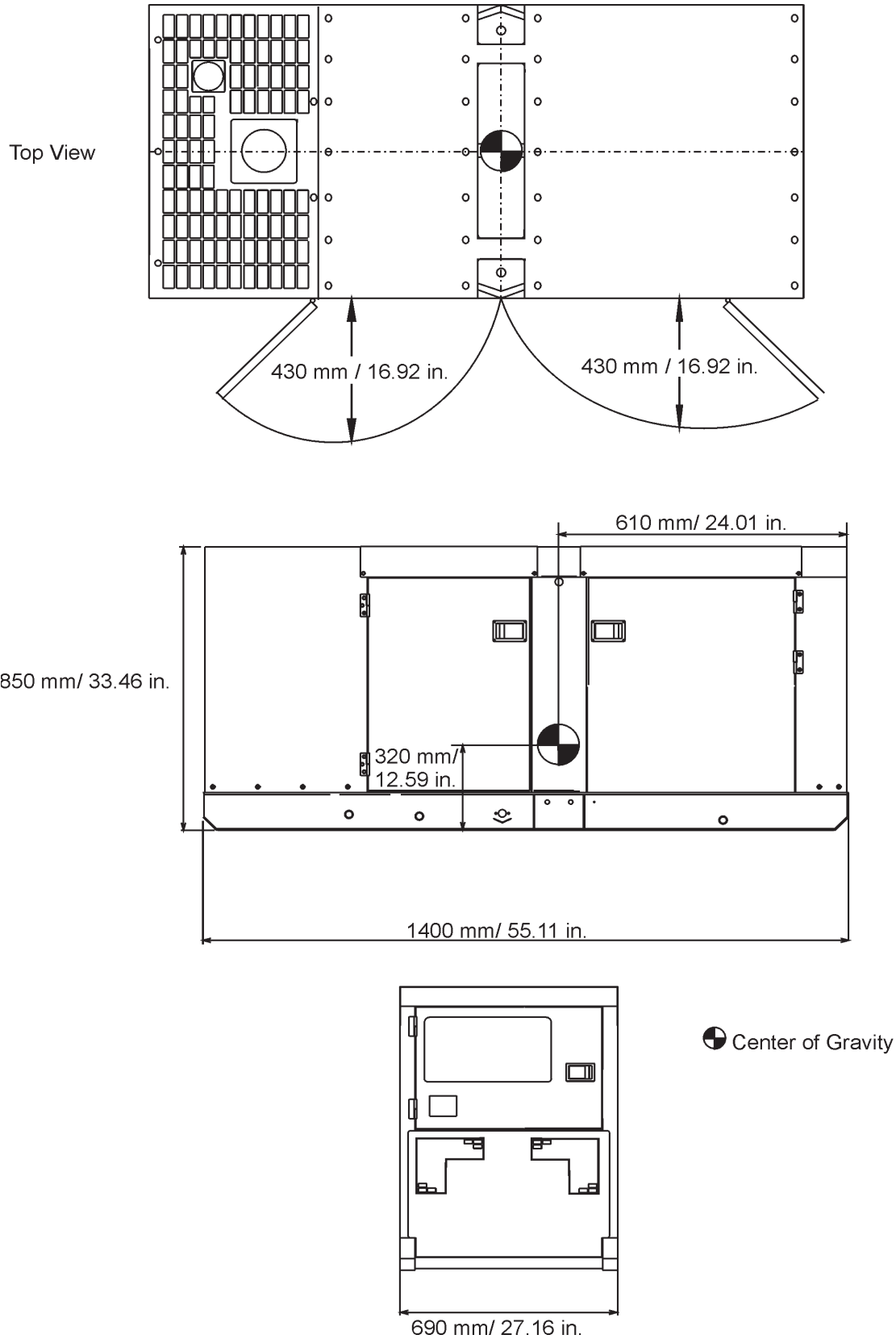

**Figure 5. Dimensions**





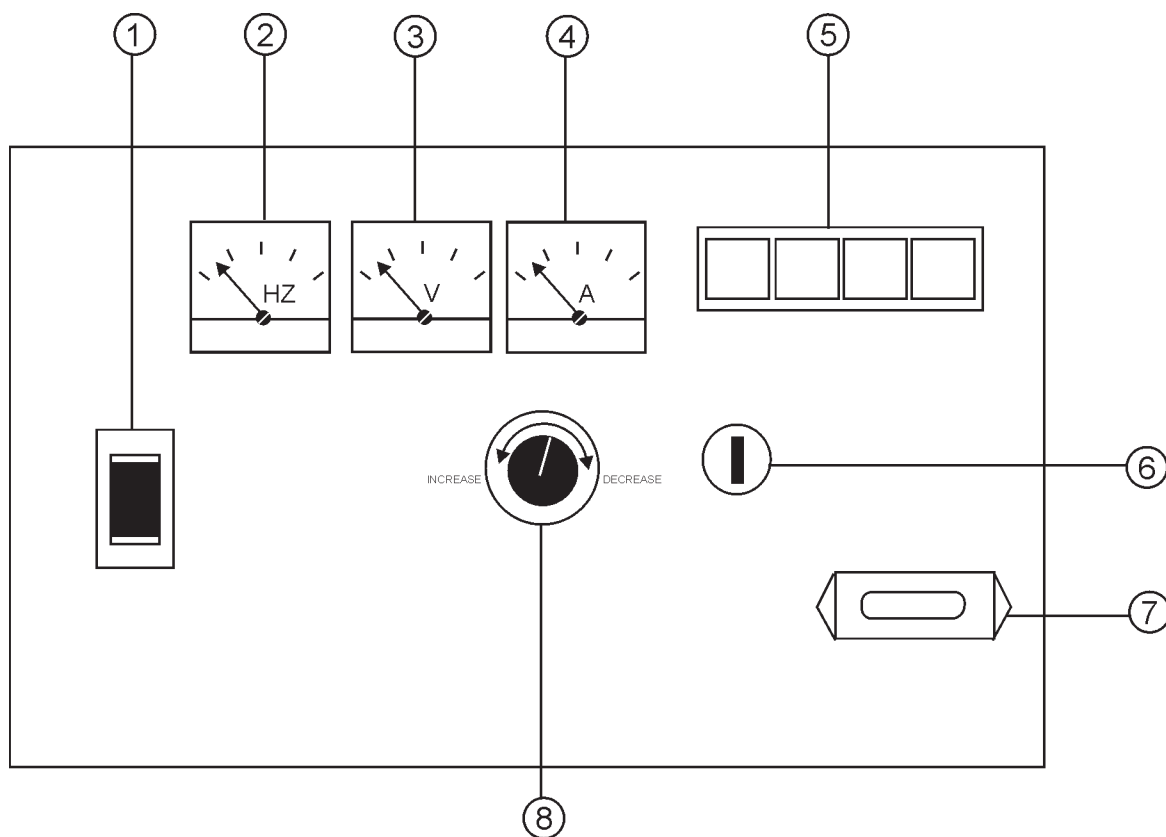

NO	DESCRIPTION
1	CIRCUIT BREAKER
2	FREQUENCY METER
3	AC VOLTMETER
4	AC AMMETER
5	INDICATOR LAMP
6	STARTER SWITCH
7	HOUR METER
8	VOLTAGE REGULATOR

**Figure 6. Control Panel**

The definitions below describe the controls and functions of the TLG-12SPX "**Control Panel**" (Figure 6).

1. **Circuit Breaker** – This three-pole, 65 amp breaker is provided to protect the UNV voltage output terminals from overload.
2. **Frequency Meter** – Indicates the output frequency in hertz (Hz). Normally 60 Hz  $\pm$ 1 Hz .
3. **AC Voltmeter** – Indicates the single phase output voltage present at the UNV terminals.
4. **AC Ammeter** – Indicates the amount of current the load is drawing from the generator.
5. **Indicator Lamp** - This engine warning indicator will notify possible damage before it occurs:
  - A. **Oil Pressure** - the light will go on during initial start, but will go out once the engine is warm. If the oil pressure light comes on during operation, this may indicate critical low oil level.
  - B. **Charge Light** - This light indicates the battery is not charging.
  - C. **Water Temperature Light** - This light indicates the coolant temperature is abnormally high.
  - D. **Engine Protection** - This will shut down the engine if there is an abnormal event that may have occurred. This prevents damage to the engine.
6. **Starter Switch** - This is to turn on and off the engine with a key.
7. **Hour Meter** - This indicates the amount of time the generator has been running.
8. **Voltage Regulator Control** – Allows manual adjustment of the generator output voltage.

# TLG-12SPX — ENGINE OPERATING/OUTPUT TERMINAL PANEL

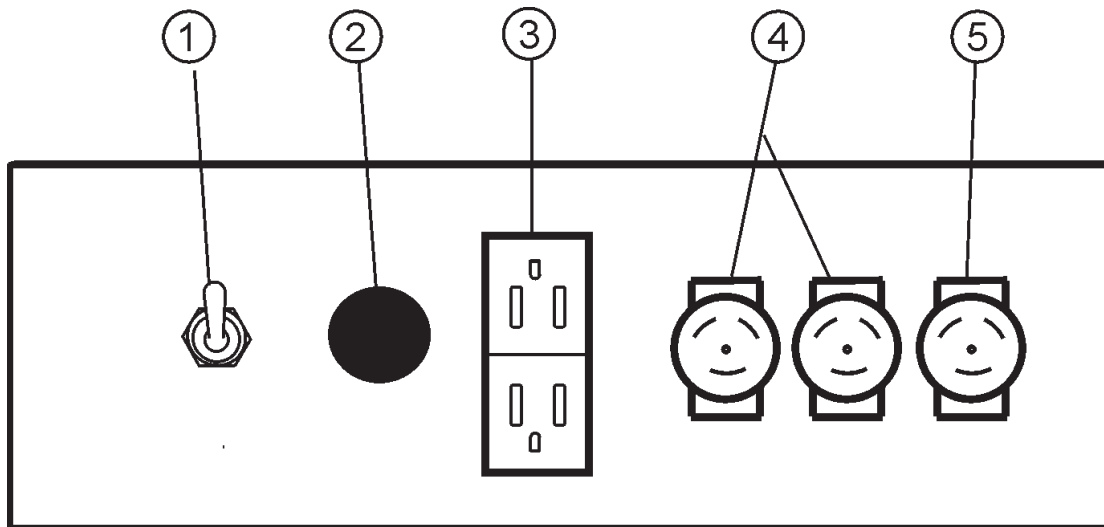

1	IDLE CONTROL SWITCH
2	THROTTLE HANDLE
3	GFCI RECEPTACLE
4	NEMA RECEPTACLES
5	NEMA CS-6369 RECEPTACLE

Figure 7. Engine Control/ Output Terminal Panel

# TLG-12SPX — ENGINE OPERATING/OUTPUT TERMINAL PANEL

The definitions below describe the controls and functions of the TLG-12SPX " **Engine Operating/Output Terminal Panel**" (Figure 7).

1. **Idle Control Switch** - This switch is used to change the idle of the engine from low to high (on some models)

2. **Throttle Handle** - This handle is used for initial start up of the engine.

3. **GFCI Receptacle** - This is a 20A, 120V parallel slot with a U-ground.



GFCI RECEPTACLE

4. **NEMA receptacle** - These output receptacles are locking type. Both are 30 amps, one is 120V, the other 240V.

5. **NEMA CS-6369 receptacle** - This locking type output receptacle is a 50 amp, 120/240V.

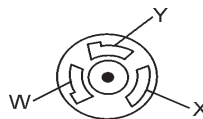

NEMA CS-6369 RECEPTACLE

## TLG-12SPX FAMILIARIZATION

The Output Terminal panel is provided with the following:

- One GFCI 120 Volt Receptacle, 20 Amp (single-phase)
- Ground Terminal (for GFCI receptacle)
- Main Circuit Breaker 50 amps
- GFCI Circuit Breaker 20 amps
- NEMA L530R Output Receptacle
- NEMA L630R Output Receptacle
- NEMA CS6369 Output Receptacle

## Output Terminal Panel

The Output Control Panel (See Figure 6) is located on the rear (Control Panel) end of the generator. The UNV lugs are protected by a face plate cover that can be secured in the close position by a 6mm bolt (See Figure 7).

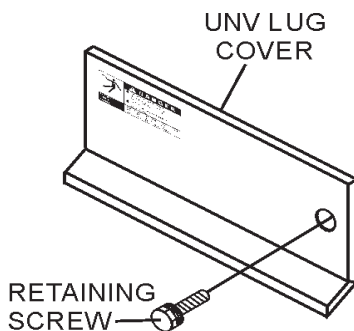

Figure 8. Retaining Bolt

## 120 Volt Receptacle

One GFCI Duplex Nema 5-20R (120V, 20 Amp) receptacle is provided on the output terminal. This receptacle can be used anytime the generator is in operation. The receptacle is controlled by the circuit breaker located on the control panel.

Pressing the reset button will reset the GFCI receptacle if it is tripped. Pressing the "Test Button" (See Figure 2) in the center of this receptacle will check the GFCI function. The receptacle should be tested at least once a month.

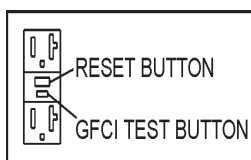

Figure 9. GFCI Test Button

## NEMA L5-30R Output Receptacle

The L5-30R receptacle supplies 30 amps at 120 volts. A 30 amp circuit breaker helps protect any load being used.

## NEMA L6-30R Output Receptacle

The L6-30R is a receptacle that supplies 30 amps at 240 volts. The 30 amp circuit breaker helps protect any load being used.

## NEMA CS-6369 Output Receptacle

The CS-6369 is a receptacle that supplies 50 amps at 120/240 volts. A 50 amp circuit breaker helps protect any load being used. See Figure 12 for details.

## Connecting Load

Loads are to be connected to the generator by the receptacles supplied. Make sure to read the operation manual before attempting to connect a load to the generator.

## Maximum Output

The entire load connected to the UNV Lugs and both slots in the duplex receptacle must not exceed 13 kW in standby or 12 kW in prime output.

## Maximum Amps

The generator unit provides 50 amps of power. **Do not exceed the maximum amps!**

## Output Terminal Panel Available Voltages

The TLG12SPX is a single phase generator only. It is able to supply both 120 volt and 240 volt.

### NOTE

**When using plural single phase voltages, make sure to balance the load on each of the single phase legs.**

# TLG-12SPX — OUTPUT TERMINAL PANEL

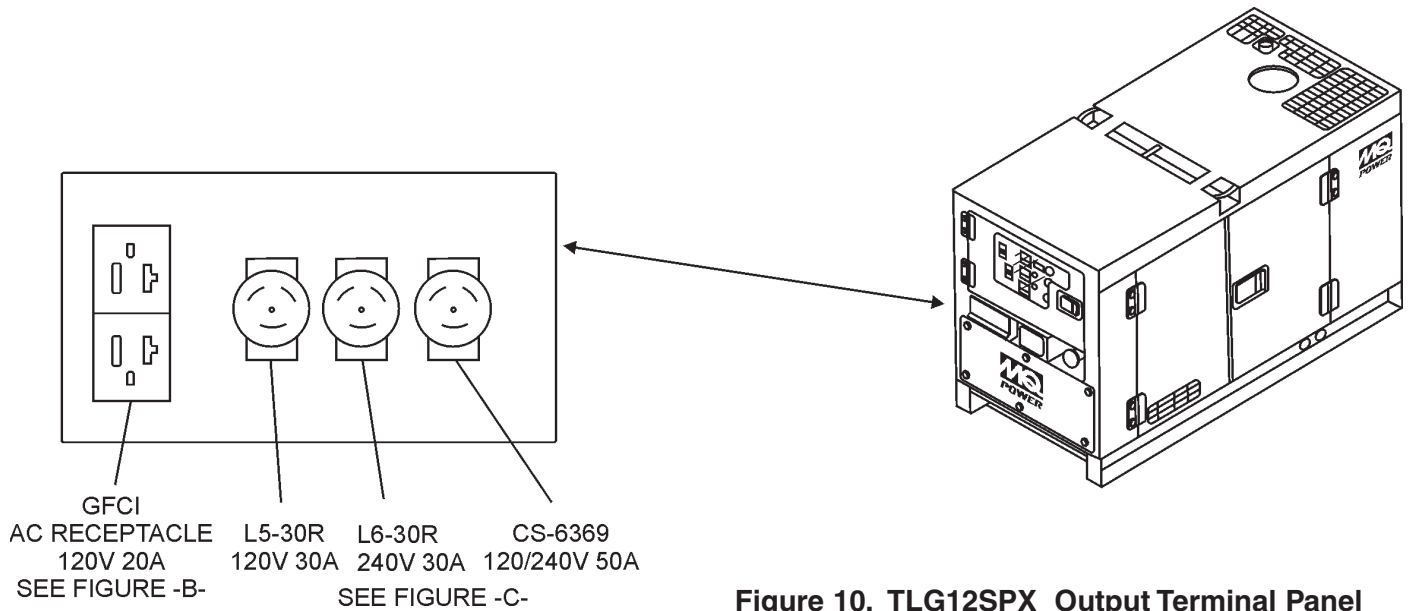

Figure 10. TLG12SPX Output Terminal Panel

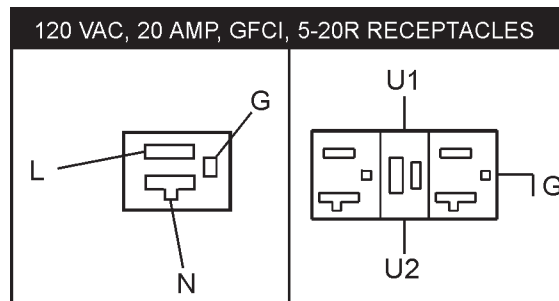

Figure 11. 5-20R Receptacles Details

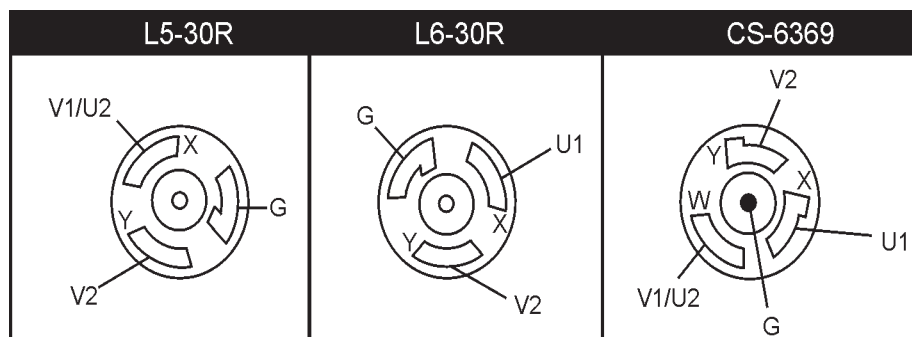

Figure 12. NEMA Receptacles Details



## Outdoor Installation

Install the generator in a location where it will not be exposed to rain or sunshine. Make sure the generator is on secure level ground so it cannot slide or shift around. Also install the generator so the exhaust will not be discharged in the direction of nearby homes.

The installation site must be relatively free from moisture and dust. All electrical equipment should be protected from excessive moisture. Failure to do will result in deterioration of the insulation and will result in short circuits and grounding.

Foreign materials such as dust, sand, lint and abrasive materials have a tendency to cause excessive wear to the engine parts and alternator.

## CAUTION :



Pay close attention to ventilation when operating the generator inside tunnels and caves. The engine exhaust contains noxious elements. Engine exhaust must be routed to a ventilated area.

## Indoor Installation

Exhaust gases from diesel engines are extremely poisonous. Whenever an engine is installed indoors the exhaust fumes must be vented to the outside. The engine should be installed at least two feet from any outside wall. Using an exhaust pipe which is too long or too small can cause excessive back pressure which will cause the engine to heat excessively and possibly burn the valves.

## CAUTION :



An electric shock may happen when vibrators are used. Pay close attention to handling when operating vibrators and always use rubber boots and gloves to insulate the body from electrical shock.

## Generator Grounding

To guard against electrical shock and possible damage to the equipment, it is important to provide a good **EARTH** ground.

Article 250 (Grounding) of the National Electrical Code (NEC) provides guide lines for proper grounding and specifies the cable ground shall be connected to the grounding system of the building as close to the point of cable entry as practical.

NEC articles 250-64(b) and 250-66 set the following grounding requirements:

1. Use one of the following wire types to connect the generator to earth ground.
  - a. Copper - 10 AWG (5.3 mm<sup>2</sup>) or larger.
  - b. Aluminum - 8 AWG (8.4 mm<sup>2</sup>) or larger.
2. When grounding the generator (Figure 13) connect the ground cable between the lock washer and the nut on the generator and tighten the nut fully. Connect the other end of the ground cable to earth ground.
3. NEC article 250-52(c) specifies that the earth ground rod should be buried a minimum of 8 ft. into the ground.

## NOTE

When connecting the generator to any buildings electrical system **ALWAYS** consult with a licensed electrician.

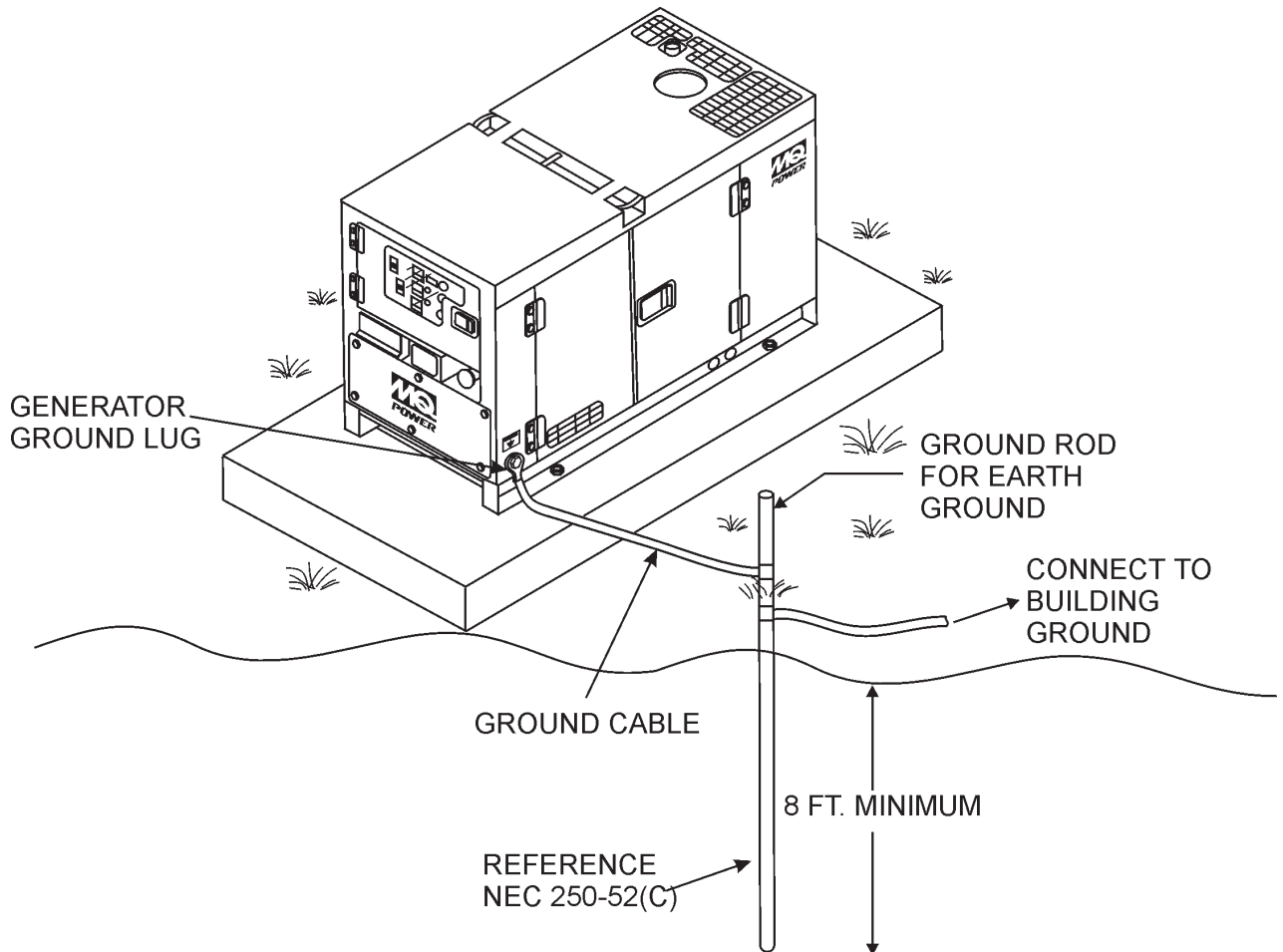

Figure 13. Typical Generator Grounding Application

## General Inspection Prior to Operation

The TLG-12SPX generator has been thoroughly inspected and accepted prior to shipment from the factory. However, be sure to check for damaged parts or components, or loose nuts and bolts, which could have occurred in transit.

## Circuit Breaker

To protect the generator from an overload, a 3-pole, 65 amp, circuit breaker is provided to protect the UNV output terminals from overload. Make sure to switch circuit breaker to the "OFF" position prior to starting the engine.

## Extension Cable

When electric power is to be provided to various tools or loads at some distance from the generator, extension cords are normally used. Cables should be sized to allow for distance in length and amperage so that the voltage drop between the generator and point of use (load) is held to a minimum. Use the Cable Selection Guide (Table 6) as a guide for selecting proper cable size.

### NOTE

**ALWAYS** consult with a licensed electrician for correct extension cord wire size.

**Table 6. Cable Selection (60 Hz, Single Phase Operation)**

Current in Amperes	Load In Watts		Maximum Allowable Cable Length			
	At 120 Volts	At 240 Volts	#10 Wire	#12 Wire	#14 Wire	#16 Wire
2.5	300	600	1000 ft.	600 ft.	375 ft.	250 ft.
5	600	1200	500 ft.	300 ft.	200 ft.	125 ft.
7.5	900	1800	350 ft.	200 ft.	125 ft.	100 ft.
10	1200	2400	250 ft.	150 ft.	100 ft.	
15	1800	3600	150 ft.	100 ft.	65 ft.	
20	2400	4800	125 ft.	75 ft.	50 ft.	

**CAUTION:** Equipment damage can result from low voltage.

**Lubrication Oil**

Fill the engine crankcase with lubricating oil through the filler hole, but do not overfill. Make sure the generator is level. With the dipstick inserted all the way, but without being screw into the filler hole, verify that the oil level is maintained between the two notches (Figure 14) on the dipstick. See Table 7 for proper selection of engine oil.

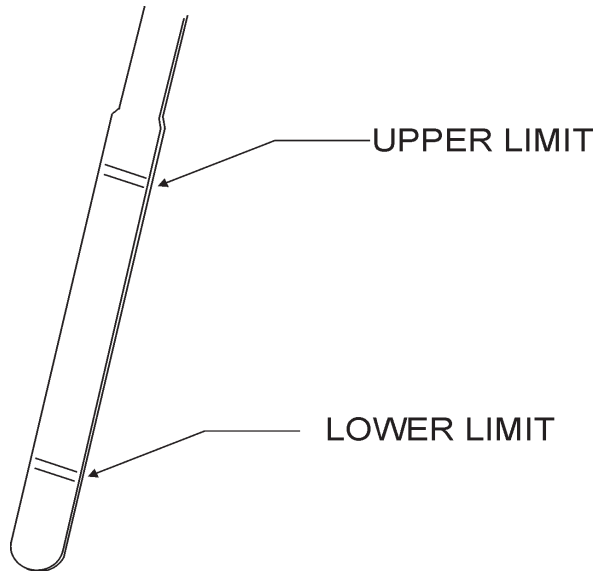

**Figure 14. Engine Oil Dipstick**

When checking the engine oil, be sure to check if the oil is clean and viscous. If the oil is not clean, drain the oil by removing the oil drain plug, and refill with the specified amount of oil as outlined in the **Isuzu Engine Owner's Manual**.

**Fuel**

Fill the fuel tank with clean and fresh **diesel fuel**. **DO NOT** fill the tank beyond capacity.

Pay attention to the fuel tank capacity when replenishing fuel. Refer to the fuel tank capacity listed on page 19, Specification Table 5.

The fuel tank cap must be closed tightly after filling. Handle fuel in a safety container. If the container does not have a spout, use a funnel. Wipe up any spilled fuel immediately.

**CAUTION:**

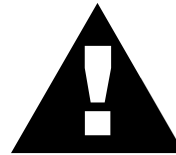

Never fill the fuel tank while the engine is running or in the dark. Diesel spillage on a hot engine can cause a fire or explosion. If diesel spillage occurs, wipe up the spilled diesel completely to prevent fire hazards.

**Coolant**

Use only drinkable tap water. If hard water or water with many impurities is used, the inside of the engine and radiator may become coated with deposits and cooling efficiency will be reduced.

An anticorrosion additive added to the water will help prevent deposits and corrosion in the cooling system. See the engine manual for further details.

**Table 7. Recommended Motor Oil**

Temperature Range	Type Oil
104° F ~ 23° F (40° C ~ -5°C)	SAE 30 or SAE 40
23° F ~ 5° F (-5° C ~ -15°C)	SAE 20 or SAE 20W
Below 5° C (-15°)	SAE 10W or SAE 5W-20

## CAUTION :



When adding coolant or antifreeze to the radiator, do not remove the radiator cap until the unit has completely cooled.

Day-to-day addition of coolant is done from the reserve tank. When adding coolant to the radiator, . See Table 8 for engine, radiator, and reserve tank coolant capacities. Make sure the coolant level in the reserve tank is always between the "H" and the "L" markings.

Table 8. Coolant Capacity

Engine and Radiator	0.92 Gal. (3.5L)
Reserve Tank	0.26 Gal. (1L)

### Operation in Freezing Weather

When operating in freezing weather, be certain the proper amount of antifreeze (Table 9) has been added.

Table 9. Anti-Freeze Operating Temperatures

Vol % Anti-Freeze	Freezing Point		Boiling Point	
	°C	°F	°C	°F
40	-24	-12	106	222
50	-37	-34	108	226

### NOTE

*When the antifreeze is mixed with water, the antifreeze mixing ratio must be less than 50%.*

### Cleaning the Radiator

The engine may overheat if the radiator fins become overloaded with dust or debris. Periodically clean the radiator fins with compressed air. Cleaning inside the machine is dangerous, so clean only with the engine turned off and the battery disconnected.

### Air Cleaner

Periodic cleaning/replacement is necessary. Inspect it in accordance with the **Isuzu Engine Owner's Manual**.

### Fan Belt Tension

A slack fan belt may contribute to overheating, or to insufficient charging of the battery. Inspect the fan belt for damage and wear and adjust it in accordance with the **Isuzu Engine Owner's Manual**.

The fan belt tension is proper if the fan belt bends 7 to 10 mm (Figure 15) when depressed with the thumb as shown below.

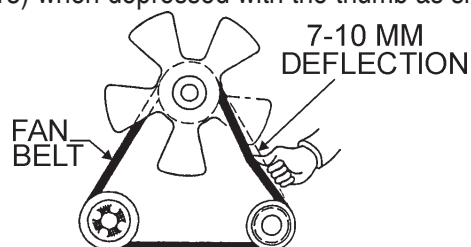

Figure 15. Fan Belt Tension

## CAUTION :



Never place hands near the belts or fan while the generator set is running.

## Battery

This unit is of negative ground. **DO NOT** connect in reverse. Always maintain battery fluid level between the specified marks. Battery life will be shortened, if the fluid level is not properly maintained. Add only distilled water when replenishment is necessary.

The battery is sufficiently charged if the specific gravity of the battery fluid is 1.28 (at 68° F). If the specific gravity should fall to 1.245 or lower, it indicates that the battery is dead and needs to be recharged or replaced.

Check to see whether the battery cables are loose. Poor contact may result in poor starting or malfunctions. Always keep the terminals firmly tightened. Coating the terminals with a thin film of grease will help to inhibit corrosion.

## Battery Cable Installation

**ALWAYS** be sure the battery cables (Figure 16) are properly connected to the battery terminals as shown below. The **RED** cable is connected to the positive terminal of the battery, and the **BLACK** cable is connected to the negative terminal of the battery.

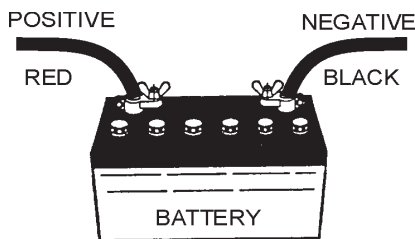

Figure 16. Battery Connections

## CAUTION :



If the battery cable is connected incorrectly, electrical damage to the generator will occur. Pay close attention to the polarity of the battery when connecting the battery.

When connecting battery do the following:

1. Place a small amount of grease around both battery terminals. This will ensure a good connection and will help prevent corrosion around the battery terminals.

## CAUTION :



Inadequate battery connections may cause poor starting of the generator, and create other malfunctions.

## Wiring

Inspect the entire generator for bad or worn electrical wiring or connections. If any wiring or connections are exposed (insulation missing) replace wiring immediately.

## Piping and Hose Connection

Inspect all piping, oil hose, and fuel hose connections for wear and tightness. Tighten all hose clamps and check hoses for leaks.

If any hose (fuel or oil) lines are defective replace them immediately.

## Single Phase Load

Always be sure to check the nameplate on the generator and equipment to insure the wattage, amperage and frequency requirements are satisfactorily supplied by the generator for operating the equipment.

Generally, the wattage listed on the nameplate of the equipment is its rated output. Equipment may require 130—150% more wattage than the rating on the nameplate, as the wattage is influenced by the efficiency, power factor and starting system of the equipment.

## NOTE

If wattage is not given on the equipment's name plate, approximate wattage may be determined by multiplying nameplate voltage by the nameplate amperage.

$$\text{WATTS} = \text{VOLTAGE} \times \text{AMPERAGE}$$

The power factor of this generator is 1.0. See Table 10. below when connecting loads.

Table 10. Power Factor By Load	
Type Of Load	Power Factor
Single-phase induction motors	0.4 - 0.75
Electric heaters, incandescent lamps	1.0
Fluorescent lamps, mercury lamps	0.4 - 0.9
Electronic devices, communication equipment	1.0
Common power tools	0.8

### NOTE

If output (kVA) is not given on the equipment nameplate, approximate output may be determined by multiplying voltage by amperage by

$$\sqrt{3}$$

Motors and motor-driven equipment draw much greater current for starting than during operation.

An inadequate size connecting cable which cannot carry the required load can cause a voltage drop which can burn out the appliance or tool and overheat the cable.

- When connecting a resistance load such as an incandescent lamp or electric heater, a capacity of up to the generating set's rated output (kW) can be used.
- When connecting a fluorescent or mercury lamp, a capacity of up to the generating set's rated output (kW) multiplied by 0.6 can be used.
- When connecting an electric drill or other power tools, pay close attention to the required starting current capacity.

## Before Starting

### Generator and Control Panel

1. Be sure to disconnect the electrical load and switch the circuit breaker to the "OFF" position prior to starting the engine.
2. Connect the negative battery cable (BLACK) to the negative post on the battery (Figure 17).

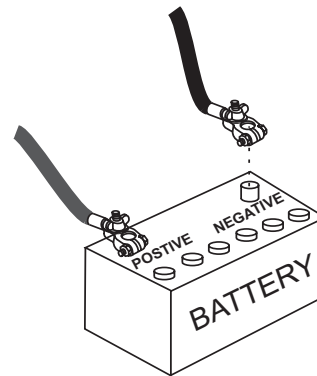
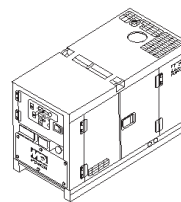
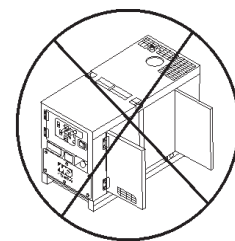

Figure 17. Battery Connections

3. Close all engine enclosure doors (Figure 18).



CORRECT



INCORRECT

Figure 18. Engine Enclosure Doors

4. Ground any equipment necessary using the ground lug on the generator, and the GFCI ground plug located on the output terminal panel, next to the throttle lever. See Figure 8, page 29 for proper grounding techniques.



## Before Starting

### Engine

1. Check the lubricating oil level prior to starting the engine. Make sure the generator is level. The oil level must be maintained between two notches on the dipstick.
2. When there is not enough lubricating oil, fill the crankcase with high grade motor oil. Use a high quality detergent oil classified CC or higher (See Table 7 on page 31).
3. Check the coolant level in the radiator and subtank. Replenish with antifreeze as necessary. Always maintain the coolant level between the **FULL** and **LOW** markings on the coolant container. Be sure that the radiator cap is fastened securely.
4. Check the fuel level on the fuel gauge. If fuel is low, fill the fuel tank with clean fresh unleaded automotive diesel. If diesel spillage occurs, completely wipe up the spilled fuel immediately.

## WARNING:



The engine's exhaust contains harmful emissions. **ALWAYS** ventilate the exhaust when operating inside tunnels, excavations or buildings. Direct exhaust away from nearby personnel.

### Starting the Generator

1. Set the Throttle switch to "Start/Idle"(Figure 19).

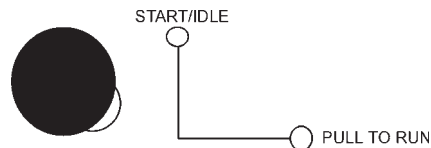

**Figure 19. Throttle Handle (Idle)**

2. Turn switch key to start. Once it is cranked and starts to run, release the key (Figure 20).



**Figure 20. Key switch**

3. Pull the throttle handle and turn to right until the notch sets the handle out. (Figure 21).

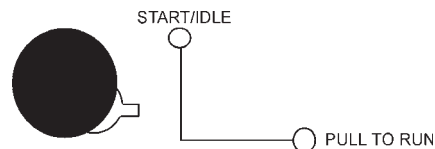

**Figure 21. Throttle Handle (Run)**

4. Turn the main circuit breaker to 'ON' (Figure 22).



**Figure 22. Main Circuit Breaker**

# TLG-12SPX — SHUTDOWN PROCEDURE

5. The generator's frequency meter (Figure 23) displays the 60 cycle output frequency in **HERTZ**.

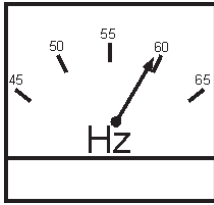

**Figure 23. Frequency Meter (Hz)**

6. The generator's voltage meter (Figure 24) displays the 120 VAC in **VOLTS**. If the voltage is not within the specified frequency tolerance, use the voltage adjustment control knob (Figure 25) to increase or decrease the desired voltage.

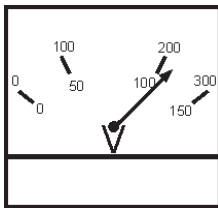
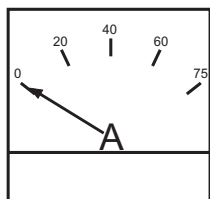

**Figure 24. Voltage Meter (Volts)**



**Figure 25. Voltage Adjust Control Knob**

7. The ammeter (Figure 26) will indicate zero amps with no load applied. When a load is applied, this meter will indicate the amount of current that the load is drawing from the generator's alternator.



**Figure 26. Ammeter (No Load)**

8. Set the circuit breaker to "ON". Observe the generator's ammeter (Figure 27) and verify it reads the anticipated amount of current with respect to the load. The ammeter will only display a current reading if the load is in use.

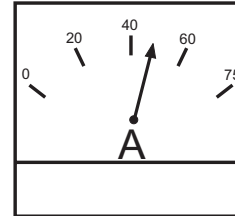

**Figure 27. Ammeter (Load)**

9. The generator will run until manually stopped or an abnormal condition occurs.

## ENGINE SHUTDOWN

To shutdown the generator, use the following procedure:

1. Turn off all equipment attached to generator. Switch the Circuit Breaker to 'OFF'.
2. Turn the throttle handle to the left and push in.
3. Let the engine cool by running it for 3-5 minutes with no load applied.
4. Turn the key to 'STOP' position and remove the key.



## General Inspection

Prior to each use, the generating set should be cleaned and inspected for deficiencies. Check for loose, missing or damaged nuts, bolts or other fasteners. Also check for fuel or oil leaks.

**Engine Side, Fuel, Oil and Coolant** (Refer to the Engine Instruction Manual)

## Air Cleaner

Every 50 hours: Remove air cleaner element and clean heavy duty paper element with kerosene, or foam element with liquid detergent and hot water. Wrap foam element in a cloth and squeeze dry. For heavy duty paper element, wipe excess kerosene with towel

## Fuel Addition

Add diesel fuel (the grade may vary according to season and locations). Always pour through the mesh filter.

## Removing Water from the Tank

After prolonged use, water and other impurities accumulate in the bottom of the tank. Occasionally remove the drain cock and drain the contents. During cold weather, the greater the empty volume inside the tank, the easier it is for water to condense. This can be reduced by always keeping the tank as full as possible.

## Air Removal

If air enters the fuel injection system of a diesel engine, starting becomes impossible. After running out of fuel, or after disassembling the fuel system, bleed the system according to the following procedure.

To restart after running out of fuel, turn the key switch to the "START" position for 15-30 seconds. Try again, if needed. This unit is equipped with an automatic air bleeding system.

## Service Daily

If engine is operating in very dusty and dry grass conditions, a clogged air cleaner will result in high fuel consumption, loss of power and excessive carbon buildup in the combustion chamber.

## Cleaning the Fuel Strainer

Clean the fuel strainer if it contains dust or water. Remove dust or water in the strainer cap and wash it in diesel. Securely fasten the fuel strainer cap so that fuel will not leak. Check the fuel strainer every 200 hours of operation or once a month.

## Check Oil Level

Check the crankcase oil level prior to each use, or when the fuel tank is filled. Insufficient oil may cause severe damage to the engine. Make sure the generator is level. The oil level must be between the two notches on the dipstick as shown on page 31, Figure 9.

## Generator Storage

For storage of the generator for over 30 days, the following is required:

- Drain the fuel tank completely.
- Completely drain the oil from the crankcase and refill with fresh oil.
- Clean all external parts of the generator with a cloth.
- Cover the generating set and store in a clean, dry place.

INSPECTION / MAINTENANCE		10 Hrs DAILY	250 Hrs	500 Hrs	1000 Hrs
ENGINE	Check Engine Fluid Levels	X			
	Check Air Cleaner	X			
	Check Battery Acid Level	X			
	Check Fan Belt Condition	X			
	Check for Leaks	X			
	Check for Loosening of Parts	X			
	Check Water Separator	X			
	Replace Engine Oil and Filter *1		X		
	Clean Air Filter		X		
	Drain Bottom of Fuel Tank		X		
	Clean Unit, Inside and Outside		X		
	Change Fuel Filter *2			X	
	Clean Radiator and Check Coolant Protection Level			X	
	Replace Air Filter Element				X
	Check all Hoses and Clamps				X
Clean Inside of Fuel Tank				X	
GENERATOR	Measure Insulation Resistance Over 3M ohms		X		

\*1 Replace engine oil and filter at 100 hours, first time only.

\*2 Replace fuel filter at 250 Hours, first time only.

# TLG-12SPX — ENGINE WIRING DIAGRAM

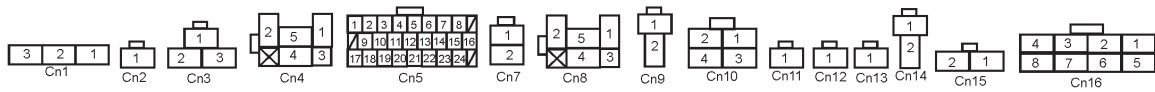
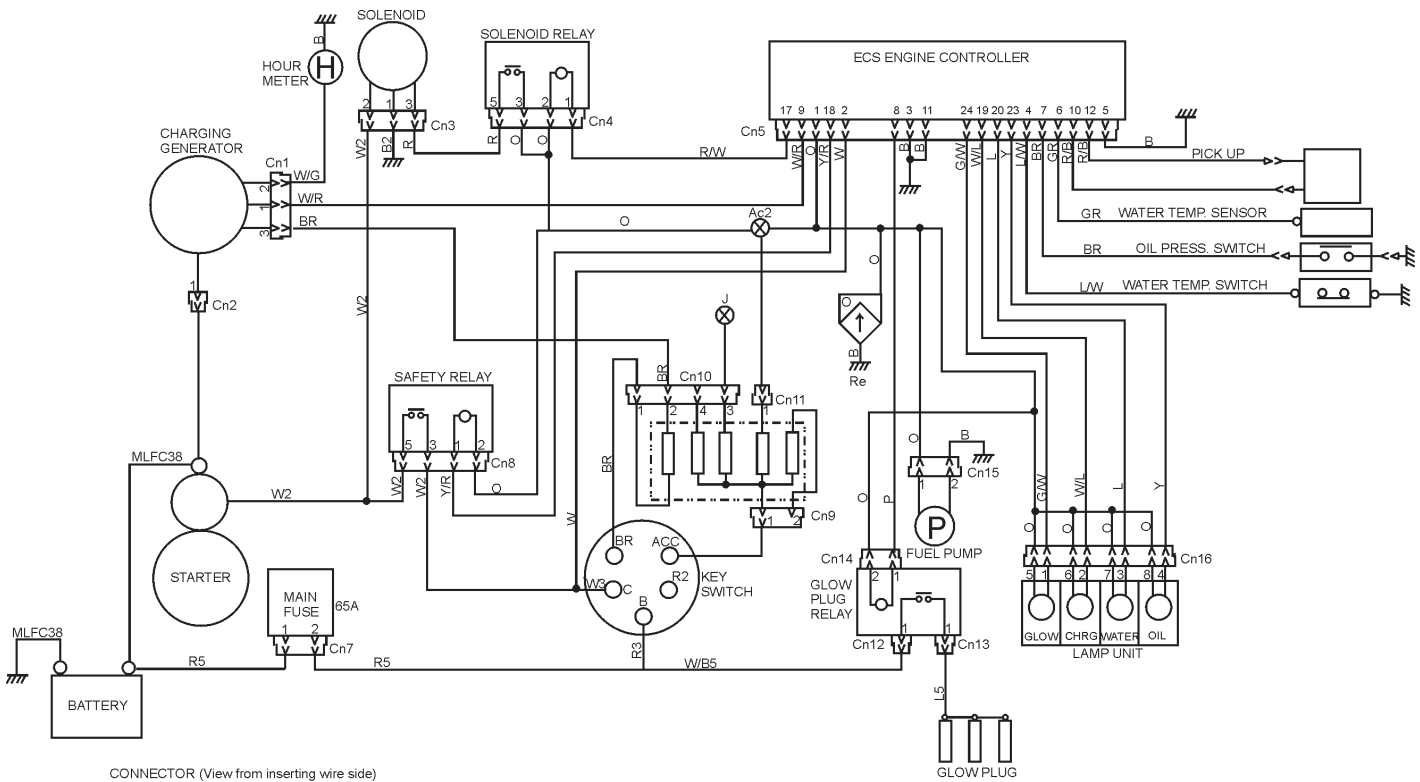

WIRING COLOR CODE			
SYMBOL	COLOR	SYMBOL	COLOR
B	BLACK	R	RED
L	BLUE	W	WHITE
BR	BROWN	Y	YELLOW
G	GREEN	LB	LT BLUE
GR	GRAY	LG	LT GREEN
V	VIOLET	O	ORANGE
P	PINK		

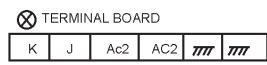
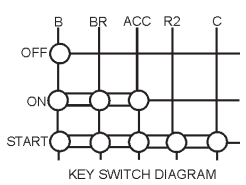

# TLG-12SPX — GENERATOR WIRING DIAGRAM

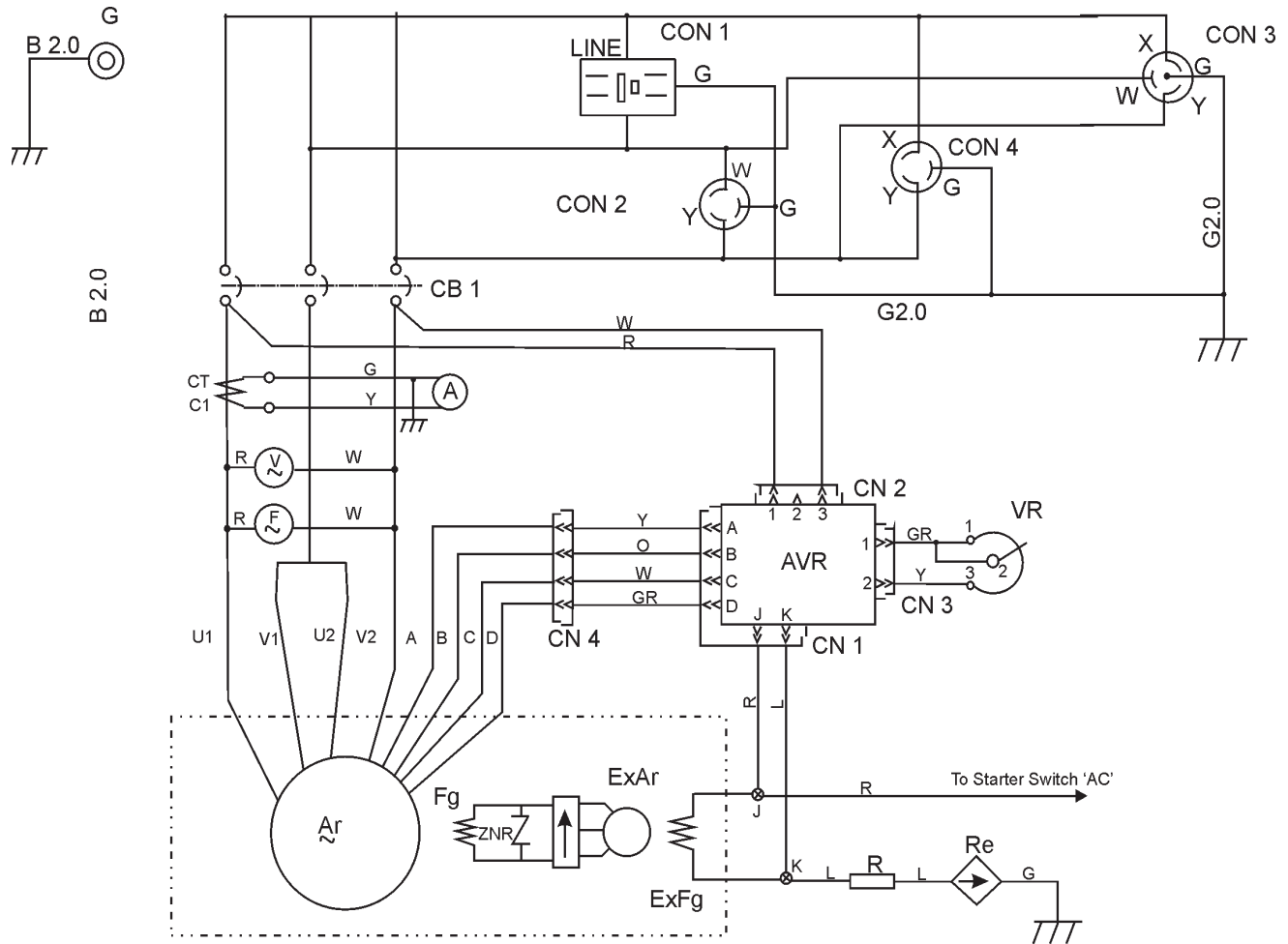

Connector  
(View at Wiring Side)

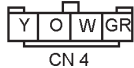
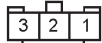

WIRING COLOR CODE			
SYMBOL	COLOR	SYMBOL	COLOR
B	Black	R	Red
L	Blue	W	White
BR	Brown	Y	Yellow
G	Green	LB	Light Blue
GR	Grey	LG	Light Green
V	Violet	O	Orange
P	Pink		



SYMBOL	PARTS NAME
Ar	Armature Coil
Fg	Field Coil
ExAr	Armature Exciter
ExFg	Field Exciter
Re	Rectifier
R	Resistor
Y	AC Voltmeter
A	AC Ammeter
F	Frequency Meter
CT	Current Transformer, Ammeter
CB1,2	Circuit Breaker
CON1,2,3,4	Output Receptacle
AVR	Automatic Voltage Regulator
VR	Voltage Regulator
J, K	Combination Terminal
G	Ground Terminal

## TLG-12SPX — TROUBLESHOOTING (ENGINE)

Practically all breakdowns can be prevented by proper handling and maintenance inspections, but in the event of a breakdown, use the tables shown for

diagnosis based on the Engine Troubleshooting (Table 11). If the problem cannot be remedied, consult our company's business office or service plant.

**TABLE 11. ENGINE TROUBLESHOOTING**

SYMPTOM	POSSIBLE PROBLEM	SOLUTION
Engine does not start.	No fuel?	Replenish fuel.
	Air in the fuel system?	Bleed system.
	Water in the fuel system?	Remove water from fuel tank.
	Fuel pipe clogged?	Clean fuel pipe.
	Fuel filter clogged?	Clean or change fuel filter.
	Excessively high viscosity of fuel or engine oil at low temperature?	Use the specified fuel or engine oil.
	Fuel with low cetane number?	Use the specified fuel.
	Fuel leak due to loose injection pipe retaining nut?	Tighten nut.
	Incorrect injection timing?	Adjust.
	Fuel cam shaft worn?	Replace.
	Injection nozzle clogged?	Clean injection nozzle.
	Injection pump malfunctioning?	Repair or replace.
	Seizure of crankshaft, camshaft, piston, cylinder liner or bearing?	Repair or replace.
	Compression leak from cylinder?	Replace head gasket, tighten cylinder head bolt, glow plug and nozzle holder.
	Improper valve timing?	Correct or replace timing gear.
Piston ring and liner worn?	Replace.	
Excessive valve clearance?	Adjust.	
Starter does not run.	Starter malfunctioning?	Repair or replace.
	Wiring disconnected?	Connect wiring.



## TABLE 11. ENGINE TROUBLESHOOTING (CONTINUED)

SYMPTOM	POSSIBLE PROBLEM	SOLUTION
Engine revolution is not smooth.	Fuel filter clogged or dirty?	Clean or change.
	Air cleaner clogged?	Clean or change.
	Fuel leak due to loose injection pipe retaining nut?	Tighten nut.
	Injection pump malfunctioning?	Repair or replace.
	Incorrect nozzle opening pressure?	Adjust.
	Injection nozzle stuck or clogged?	Repair or replace.
	Fuel over flow pipe clogged?	Clean.
	Governor malfunctioning?	Repair.
Either white or blue exhaust gas is observed.	Excessive engine oil?	Reduce to the specified level.
	Piston ring and liner worn or stuck?	Repair or replace.
	Incorrect injection timing?	Adjust.
	Deficient compression?	Adjust top clearance.
Either black or dark gray exhaust gas is observed.	Overload?	Lessen the load.
	Low grade fuel used?	Use the specified fuel.
	Fuel filter clogged?	Clean or change.
	Air cleaner clogged?	Clean or change.
	Deficient nozzle injection?	Repair or replace the nozzle.
Deficient output.	Incorrect injection timing?	Adjust.
	Engine's moving parts seem to be seizing?	Repair or replace.
	Uneven fuel injection?	Repair or replace the injection pump.
	Deficient nozzle injection?	Repair or replace the nozzle.
	Compression leak?	Replace head gasket, tighten cylinder head bolt, glow plug and nozzle holder.

## TLG-12SPX — TROUBLESHOOTING (GENERATOR)

Practically all breakdowns can be prevented by proper handling and maintenance inspections, but in the event of a breakdown, use the tables shown for diagnosis based on the Engine and Generator Troubleshooting (Table 12). If the problem cannot be remedied, consult our company's business office or service plant.

**TABLE 17. GENERATOR TROUBLESHOOTING**

SYMPTOM	POSSIBLE PROBLEM	SOLUTION
No Voltage Output	AC Voltmeter defective?	Check output voltage using a voltmeter.
	Is wiring connection loose?	Check wiring and repair.
	Is AVR defective?	Replace if necessary.
	Defective Rotating Rectifier?	Check and replace.
Low Voltage Output	Is engine speed correct?	Turn engine throttle lever to "High".
	Is wiring connections loose?	Check wiring and repair.
	Defective AVR?	Replace if necessary.
High Voltage Output	Is wiring connections loose?	Check wiring and repair.
	Defective AVR?	Replace if necessary.
Circuit Breaker Tripped	Short Circuit in load?	Check load and repair.
	Over current?	Confirm load requirements and reduce.
	Defective circuit breaker?	Check and replace.
	Over current Relay actuated?	Confirm load requirement and replace.



# EXPLANATION OF CODE IN REMARKS COLUMN

**How to read the marks and remarks used in this parts book.**

## **Items Found In the “Remarks” Column**

**Serial Numbers**-Where indicated, this indicates a serial number range (inclusive) where a particular part is used.

**Model Number**-Where indicated, this shows that the corresponding part is utilized only with this specific model number or model number variant.

## **Items Found In the “Items Number” Column**

All parts with same symbol in the number column, \*, #, +, or %, belong to the same assembly or kit.

Note: If more than one of the same reference number is listed, the last one listed indicates newest (or latest) part available.

## **TLG-12SPX W/SUZU 3LB1 DIESEL ENGINE 1 TO 3 UNITS**

<u>Qty.</u>	<u>P/N</u>	<u>Description</u>
1 .....	0601806537 .....	CIRCUIT BREAKER
1 .....	0601820663 .....	AUTOMATIC VOLTAGE REGULATOR
1 .....	0601840073 .....	RHEOSTAT VOLTAGE REGULATOR
1 .....	0601840121 .....	KNOB RHEOSTAT
1 .....	8522015503 .....	RADIATOR HOSE (UPPER)
1 .....	8971076820 .....	RADIATOR HOSE (LOWER)
5 .....	8944567411 .....	OIL FILTER
5 .....	8970488490 .....	FUEL FILTER
5 .....	0602046202 .....	AIR ELEMENT
1 .....	1824100990 .....	UNIT OIL PRESSURE
1 .....	8941268220 .....	UNIT WATER PRESSURE
1 .....	0208006120 .....	FAN BELT

**NOTE**

**Part number on this Suggested Spare  
Parts list may supercede/replace the  
P/N shown in the text pages of this  
book.**

# TLG-12SPX --- GENERATOR ASSY.

GENERATOR ASSY.

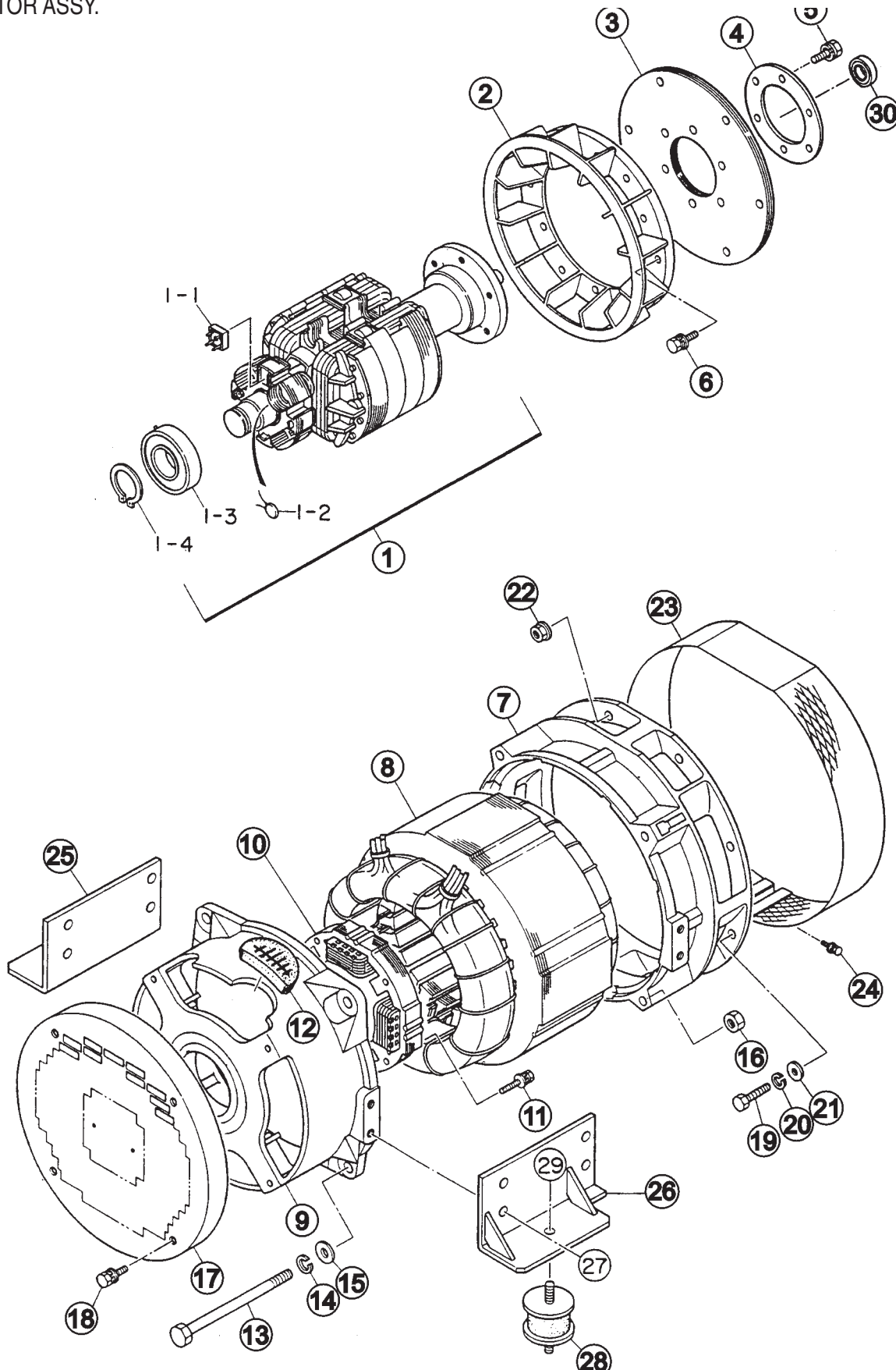

# TLG-12SPX --- GENERATOR ASSY.

## GENERATOR ASSY.

<u>NO.</u>	<u>PART NO.</u>	<u>ITEM</u>	<u>QTY.</u>	<u>REMARKS</u>
1	B0110000403	ROTOR ASSY.	1	
1-1	0601820037	RECTIFIER .....	1	S10VB60
1-2	0601822638	SURGE ABSORBER .....	1	TNR15G 431K
1-3	0071206307	BEARING .....	1	6307DDU
1-4	0080000035	SNAP RING	1	
2	1711027003	FAN	1	
3	7611611003	COUPLING DISK	1	
4	3311612004	WASHER, COUPLING HUB	1	
5	0012808025	HEX. HEAD BOLT .....	6	REPLACES 0012808025
6	0012308030	HEX. HEAD BOLT	6	
7	D4153100102	END BRACKET	1	
8	8521384003	ARMATURE ASSY.	1	
9	D4153000202	END BRACKET	1	
10	B0137000003	FIELD ASSY. EXCITER	1	
11	0017105035	HEX. HEAD BOLT	4	
12	D4153400403	GROMMET	2	
13	D4131200004	SET BOLT	4	
14	0040012000	LOCK WASHER	4	
15	031112230	PLAIN WASHER .....	4	REPLACES 0041212000
16	0030012000	HEX. HEAD BOLT	4	
17	B0131300104	COVER	1	
18	0017108030	HEX. HEAD BOLT	4	
19	012010030	HEX. HEAD BOLT .....	6	REPLACES 0010310030
20	030210250	LOCK WASHER .....	6	REPLACES 0042510000
21	031112230	PLAIN WASHER .....	6	REPLACES 0041210000
22	0207210000	HEX. NUT	2	
23	D5131300003	COVER	1	
24	0017105025	HEX. HEAD BOLT	1	
25	8521320104	GENERATOR FOOT	1	
26	8521320004	GENERATOR FOOT	1	
27	0017110025	HEX. HEAD BOLT	8	
28	7605419004A	RUBBER SUSPENSION .....	2	REPLACES 7605419004
29	0207010000	HEX. NUT	2	
30	0070506803	BEARING .....	1	6803ZZ

# TLG-12SPX --- CONTROL PANEL ASSY.

CONTROL PANEL ASSY.

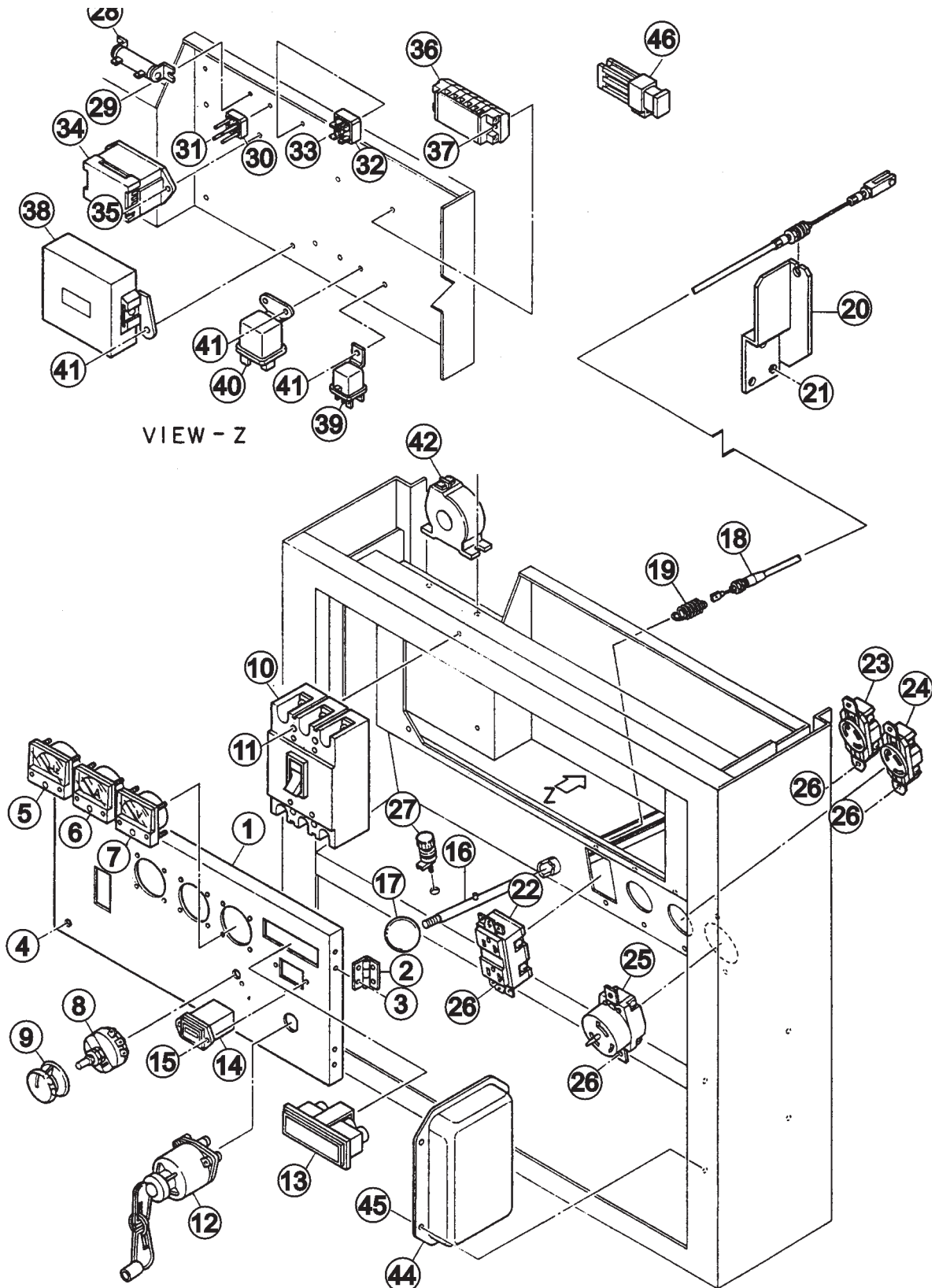



# TLG-12SPX --- CONTROL PANEL ASSY.

## CONTROL PANEL ASSY.

<u>NO.</u>	<u>PART NO.</u>	<u>ITEM</u>	<u>QTY.</u>	<u>REMARKS</u>
1	8521827203	CONTROL PANEL	1	
2	0605010060	HINGE .....	2	B1075L
3	0027103010	MACHINE SCREW .....	8	REPLACES 0021103010
4	0021806030	MACHINE SCREW	2	
5	0601800408	FREQUENCY METER .....	1	FCF5 220V 45~65Hz
6	0601805745	AC AMMETER .....	1	ACF50~75A
7	0601800281	AC VOLTMETER .....	1	SCF5A 0~150V 0~300V
8	0601840073	RHEOSTAT (VOLTAGE REGULATOR) .....	1	RA20A2SE102BJ 2W 1K OHM
9	0601840121	KNOB	1	
10	0601806537	CIRCUIT BREAKER .....	1	SC50NS 50A
11	0021004060	MACHINE SCREW	2	
	0040004000	LOCK WASHER	2	
	031104080	PLAIN WASHER .....	2	REPLACES 0041204000
12	8970444180	STARTER SWITCH .....	1	REPLACES 0602100009
	8944024980	STARTER KEY .....	2	REPLACES 0602100200
13	0601810523	INDICATOR ASSY. ....	1	PLB128Q
	0601810207	BULB	4	
14	0601800680	HOUR METER .....	1	15113
15	0027103512	MACHINE SCREW	2	
	0030003500	HEX. NUT	2	
	0040403500	WASHER	2	
16	7672142003	SLIDE LEVER	1	
17	0601840190	KNOB .....	1	REPLACES 0805012904
18	8522144103	THROTTLE CABLE	1	
19	3032143004	SPRING	1	
20	8522141004	BRACKET	1	
21	011006010	HEX. HEAD BOLT .....	3	REPLACES 0017106010
22	0601812597	RECEPTACLE .....	1	520R 125V 20A
23	0601811031	RECEPTACLE .....	1	L530R 125V 30A
24	0601811033	RECEPTACLE .....	1	L630R 250V 30A
25	0601811034	RECEPTACLE .....	1	CA6369125/250V 50A REPLACES 0601812565

# TLG-12SPX --- CONTROL PANEL ASSY.

## CONTROL PANEL ASSY.

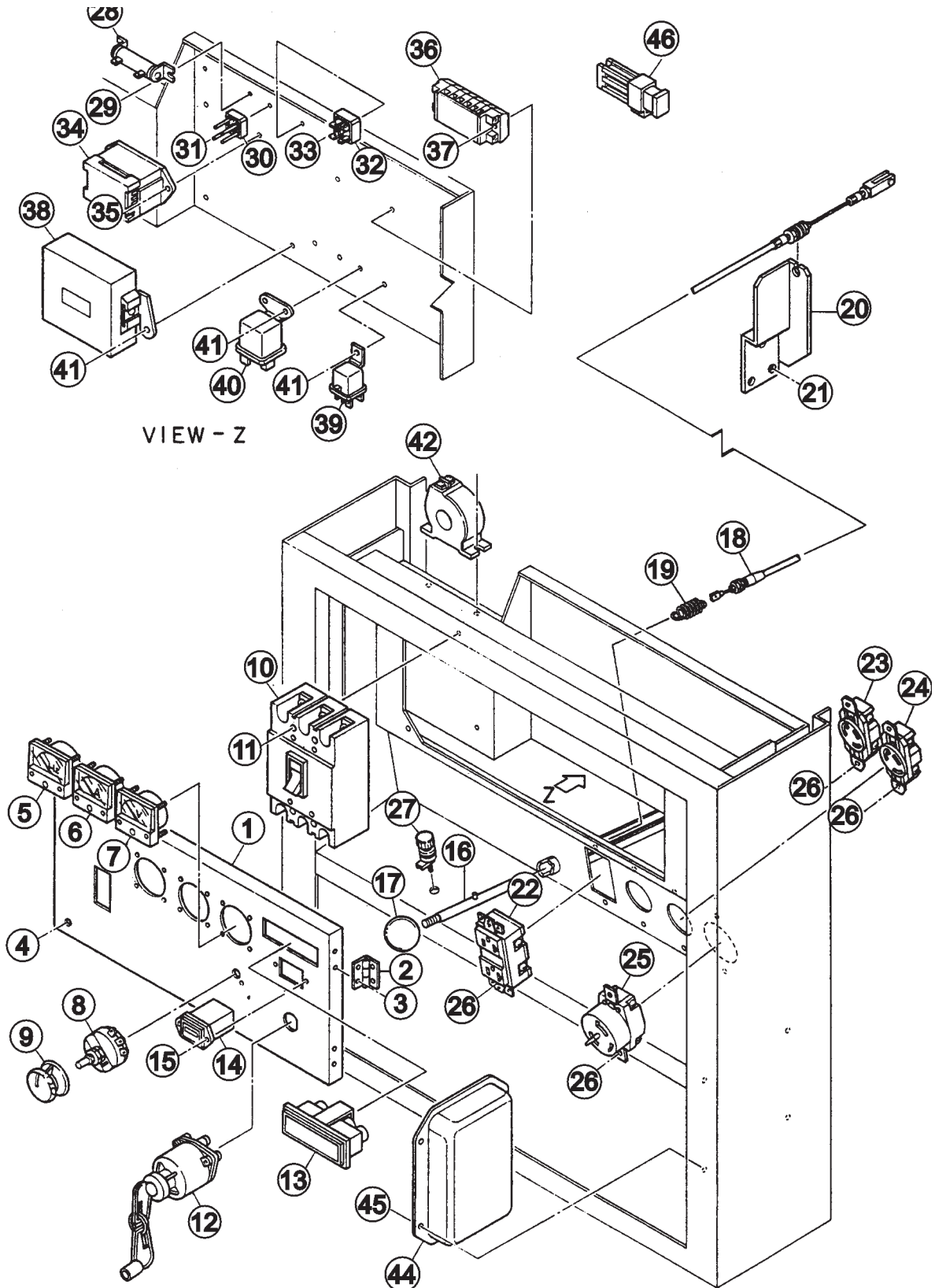

# TLG-12SPX --- CONTROL PANEL ASSY.

## CONTROL PANEL ASSY.

<u>NO.</u>	<u>PART NO.</u>	<u>ITEM</u>	<u>QTY.</u>	<u>REMARKS</u>
26	0027104012	MACHINE SCREW	8	
	003000400	HEX.NUT .....	8	REPLACES 0207004000
27	0601815109	GROUND TERMINAL .....	1	T-381
28	0601842347	RESISTOR .....	1	FF20W30 OHM
29	0027104012	MACHINE SCREW	2	
30	0601823204	RECTIFIER .....	1	S5VB60
31	0027103016	MACHINE SCREW	1	
32	0601820038	RECTIFIER .....	1	S15VB60
33	0027104025	MACHINE SCREW	1	
34	6781899004	FUSE BOX .....	1	FB6PS
	0601806642	FUSE .....	3	5A
	0601806645	FUSE .....	3	10A
	0601806644	FUSE .....	3	30A
35	0027105020	MACHINE SCREW	2	
36	0601815759	TERMINAL BOARD .....	1	KT206P
37	0027105020	MACHINE SCREW	2	
38	0602202501	CONTROLLER .....	1	ISUZU 8970912900
39	8944299470	RELAY .....	2	REPLACES 0602201206
40	8944001061	RELAY, GLOW PLUG .....	1	REPLACES 0602201206
41	0027105016	MACHINE SCREW	6	
42	0601801123	CURRENT TRANSFORMER, AMMETER..	1	COC3 150/5A
43	0017106016	HEX. HEAD BOLT	2	
44	0601820663	AUTOMATIC VOLTAGE REGULATOR .....	1	AN5201
45	0027105016	MACHINE SCREW	4	
46	0601806640	FUSE .....	1	65A

# TLG-12SPX ENGINE AND RADIATOR ASSY.

ENGINE AND RADIATOR ASSY.

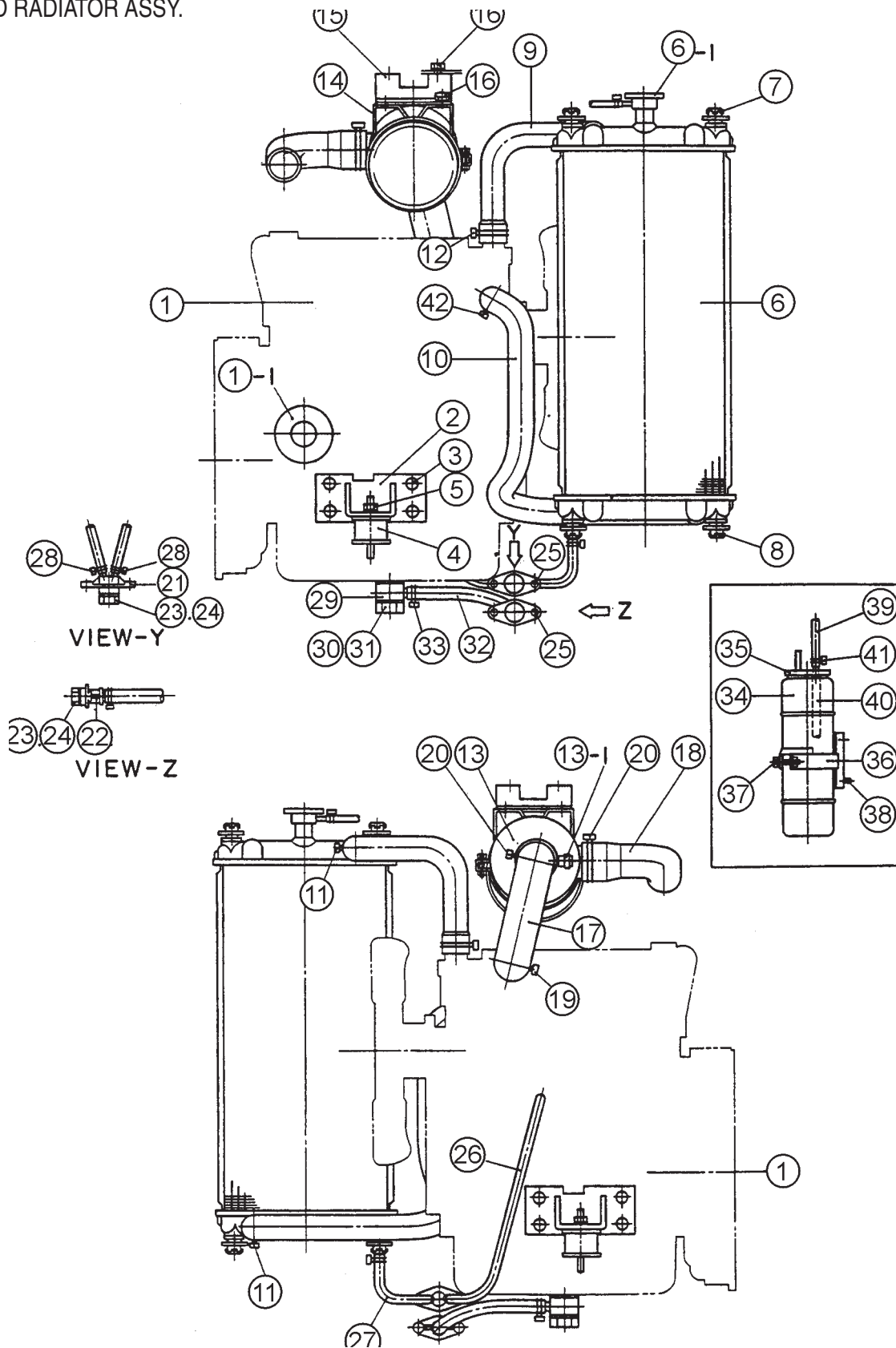

# TLG-12SPX ENGINE AND RADIATOR ASSY.

## ENGINE AND RADIATOR ASSY.

<u>NO.</u>	<u>PART NO.</u>	<u>ITEM</u>	<u>QTY.</u>	<u>REMARKS</u>
1	8520150004	ENGINE .....	1 .....	ISUZU 3LB1
1-1	8943142633	CARTRIDGE, OIL FILTER .....	1 .....	REPLACES 0602041210
	060201140	FAN BELT .....	1 .....	ISUZU 8970687980
2	8525112104	ENGINE FOOT	2	
3	0012810020	HEX. HEAD BOLT	8	
4	7605419004A	RUBBER SUSPENSION .....	2 .....	REPLACES 7605419004
5	0207010000	HEX. NUT	2	
6	0602011956	RADIATOR .....	1 .....	OB89010000
6-1	06020110888	CAP, RADIATOR .....	1 .....	R912010700
7	8702014004	RUBBER MOUNT	2	
8	605000460	RUBBER MOUNT .....	2 .....	6659210381
9	8522015503	RADIATOR HOSE	1	
10	8522015602	RADIATOR HOSE	1	
11	0605515112	HOSE BAND .....	2 .....	Ø38
12	0605515114	HOSE BAND .....	1 .....	Ø42
13	5142150140	AIR FILTER, ELEMENT .....	1 .....	REPLACES 8941521130
13-1	0602040690	INDICATOR, DUST	1	
14	8970497220	BAND, AIR CLEANER .....	2 .....	REPLACES 0602040501
15	8522031004	BRACKET, AIR CLEANER	1	
16	011008020	HEX. HEAD BOLT .....	6 .....	REPLACES 0017108020
17	8522032003	HOSE AIR CLEANER	1	
18	6602032103	HOSE AIR CLEANER	1	
19	0605515020	HOSE BAND .....	1 .....	Ø55
20	0605515001	HOSE BAND .....	2 .....	Ø60
21	1622014103	DRAIN JOINT, WATER	1	
22	1502025103C	DRAIN JOINT, OIL .....	1 .....	REPLACES 1502025103
23	0802011104	PLUG	2	
24	015000018	O RING .....	2 .....	AP18
25	0017106016	HEX. HEAD BOLT	4	
26	0199900900	DRAIN HOSE	1	
27	0199900450	DRAIN HOSE	1	
28	0605515094	HOSE BAND .....	4 .....	Ø12
29	0805010004	DRAIN JOINT	1	
30	3362054104	JOINT BOLT	1	
31	0602021190	PACKING .....	2 .....	SW22
32	0192200435	DRAIN HOSE	1	
33	0605515003	HOSE BAND .....	2 .....	Ø27
34	0802081403	RESERVE TANK	1	
35	0802081104	CAP, RESERVE TANK	1	
36	8702082004	BRACKET, RESERVE TANK	1	
37	011606025	HEX. HEAD BOLT .....	1 .....	REPLACES 0017106025
38	0017106016	HEX. HEAD BOLT	2	
39	0199900320	HOSE	1	
40	7222016304	HOSE	1	
41	060551594	HOSE BAND .....	3 .....	Ø12
42	060551526	HOSE BAND .....	1 .....	Ø44

# TLG-12SPX --- BATTERY ASSY.

BATTERY ASSY.

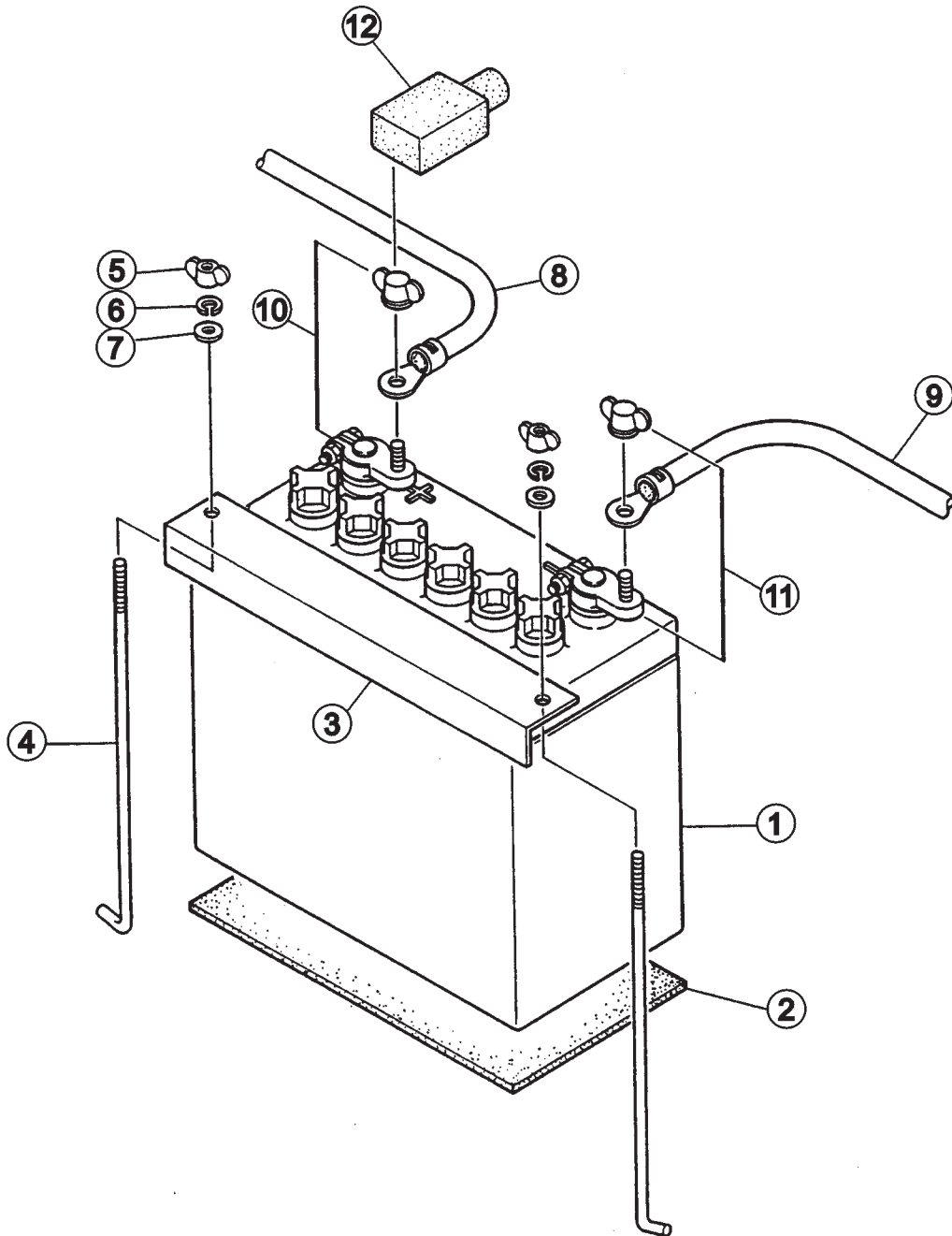

BATTERY ASSY.

<u>NO.</u>	<u>PART NO.</u>	<u>ITEM</u>	<u>QTY.</u>	<u>REMARKS</u>
1	0167306531	BATTERY .....	1 .....	65D31R
2	7612251004	BATTERY SHEET	1	
3	8522250004	BATTERY BAND	1	
4	7612252004	BATTERY BOLT	2	
5	0037808000	WING NUT	2	
6	0040008000	LOCK WASHER	2	
7	031108160	PLAIN WASHER .....	2 .....	REPLACES 0041208000
		BATTERY CABLE	1	
		BATTERY CABLE	1	
10	0602220310	TERMINAL ASSY. ....	1 .....	NO.9P
11	0602220311	TERMINAL ASSY. ....	1 .....	NO 9N
12	0602220600	TERMINAL CAP .....	1 .....	TC7R

# TLG-12SPX --- MUFFLER ASSY.

MUFFLER ASSY.

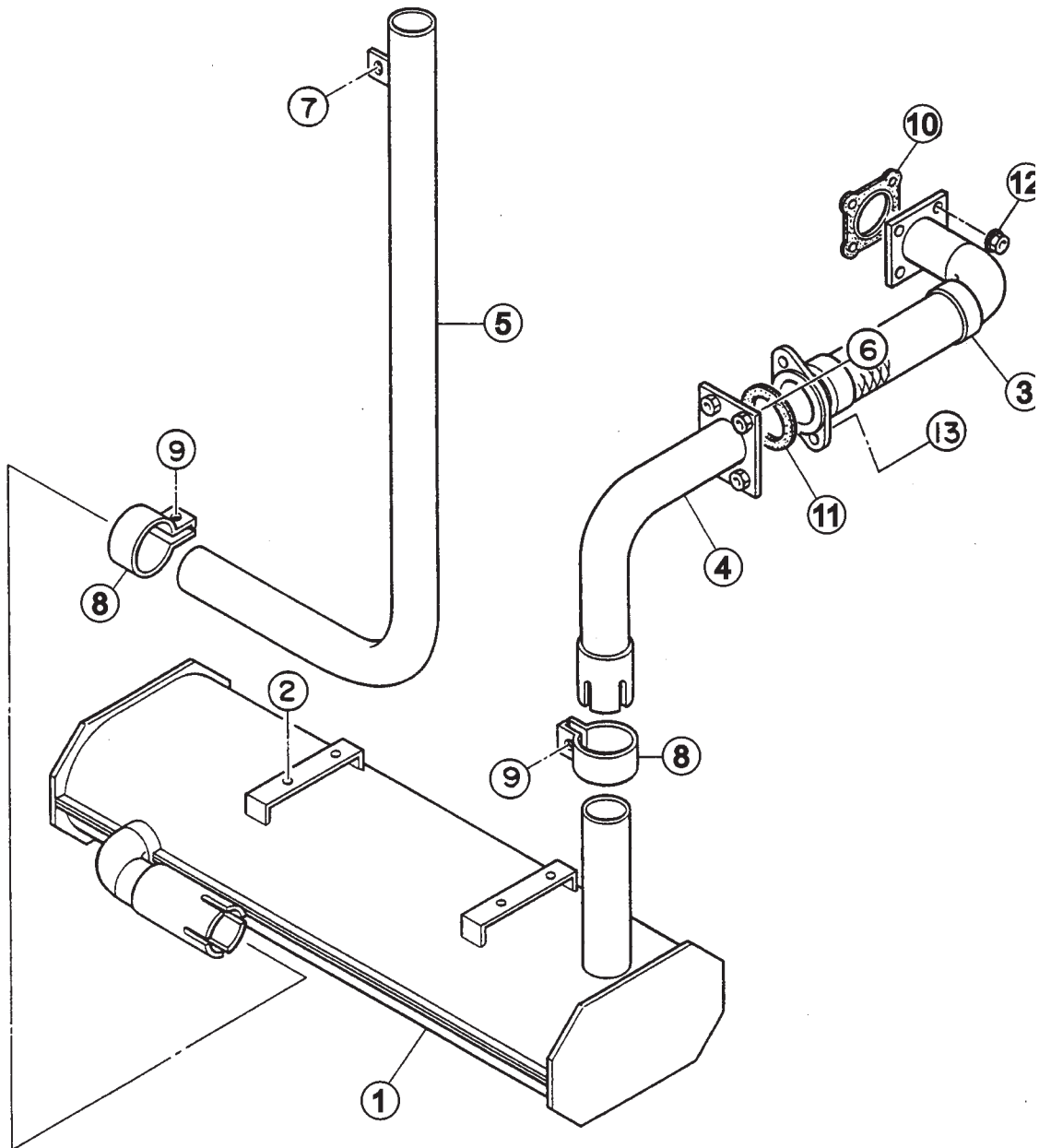



# TLG-12SPX --- MUFFLER ASSY.

## MUFFLER ASSY.

<u>NO.</u>	<u>PART NO.</u>	<u>ITEM</u>	<u>QTY.</u>	<u>REMARKS</u>
1	8522310102	MUFFLER	1	
2	011008020	HEX. HEAD BOLT .....	4 .....	REPLACES 0017108020
3	8522330003	EXHAUST PIPE	1	
4	8522332004	EXHAUST PIPE	1	
5	8522331004	EXHAUST PIPE	1	
6	011008020	HEX. HEAD BOLT .....	2 .....	REPLACES 0017108020
7	0017106016	HEX. HEAD BOLT	1	
8	3312320004	PIPE BAND	2	
9	011208035	HEX. HEAD BOLT .....	2 .....	REPLACES 0017108035
10	897042080	GASKET .....	1 .....	REPLACES 0602320110
11	1502336004	GASKET	1	
12	020108060	HEX. NUT .....	4 .....	REPLACES 0207208000
13	011208035	HEX. HEAD BOLT .....	2 .....	REPLACES 0017108035



# TLG-12SPX --- FUEL TANK ASSY.

FUEL TANK ASSY.

<u>NO.</u>	<u>PART NO.</u>	<u>ITEM</u>	<u>QTY.</u>	<u>REMARKS</u>
1	8525500003	FUEL TANK	1	
1-1	0810105900	CAP, FUEL TANK .....	1	REPLACES 0810105800
1-2	0810105900	FUEL FILTER	1	
1-3	0267700200	HOSE, FUEL GAUGE	1	
1-4	0605515005	HOSE BAND	2	
2	8525525003	BRACKET, FUEL TANK	1	
3	011008020	HEX. HEAD BOLT .....	4	REPLACES 0017108020
4	8525523004	TANK BAND	2	
5	0805003404	PAD, TANK BAND	4	
6	011008020	HEX. HEAD BOLT .....	2	REPLACES 0017108020
7	020108060	HEX.NUT .....	4	REPLACES 0207008000
8	1555527004	TANK SHEET	2	
9	7812014003	DRAIN JOINT	1	
10	0802011104	PLUG	1	
11	0150000018	O RING .....	1	AP'18
12	0017106016	HEX. HEAD BOLT	2	
13	0199900830	DRAIN HOSE	1	
14	0605515094	HOSE BAND .....	2	Ø12
15	8525546014	BRACKET	1	
16	011208025	HEX. HEAD BOLT .....	2	REPLACES 0017108025
17	8971041891	FUEL FILTER .....	1	REPLACES 1552143160
	8970713480	ELEMENT, FUEL FILTER	1	
18	0017108065	HEX. HEAD BOLT	1	
19	0602023175	FUEL PUMP .....	1	REPLACES 0602023175
20	0199900350	SUCTION HOSE	1	
21	0199900300	SUCTION HOSE	1	
22	0199900400	SUCTION HOSE	1	
23	0199700500	RETURN HOSE	1	
24	0199700270	RETURN HOSE	1	
25	0605515094	HOSE BAND .....	6	Ø12
26	0605515096	HOSE BAND .....	4	Ø8
27	1615511204	RUBBER SEAL	1	

# TLG-12SPX --- ENCLOSURE ASSY.

ENCLOSURE ASSY.

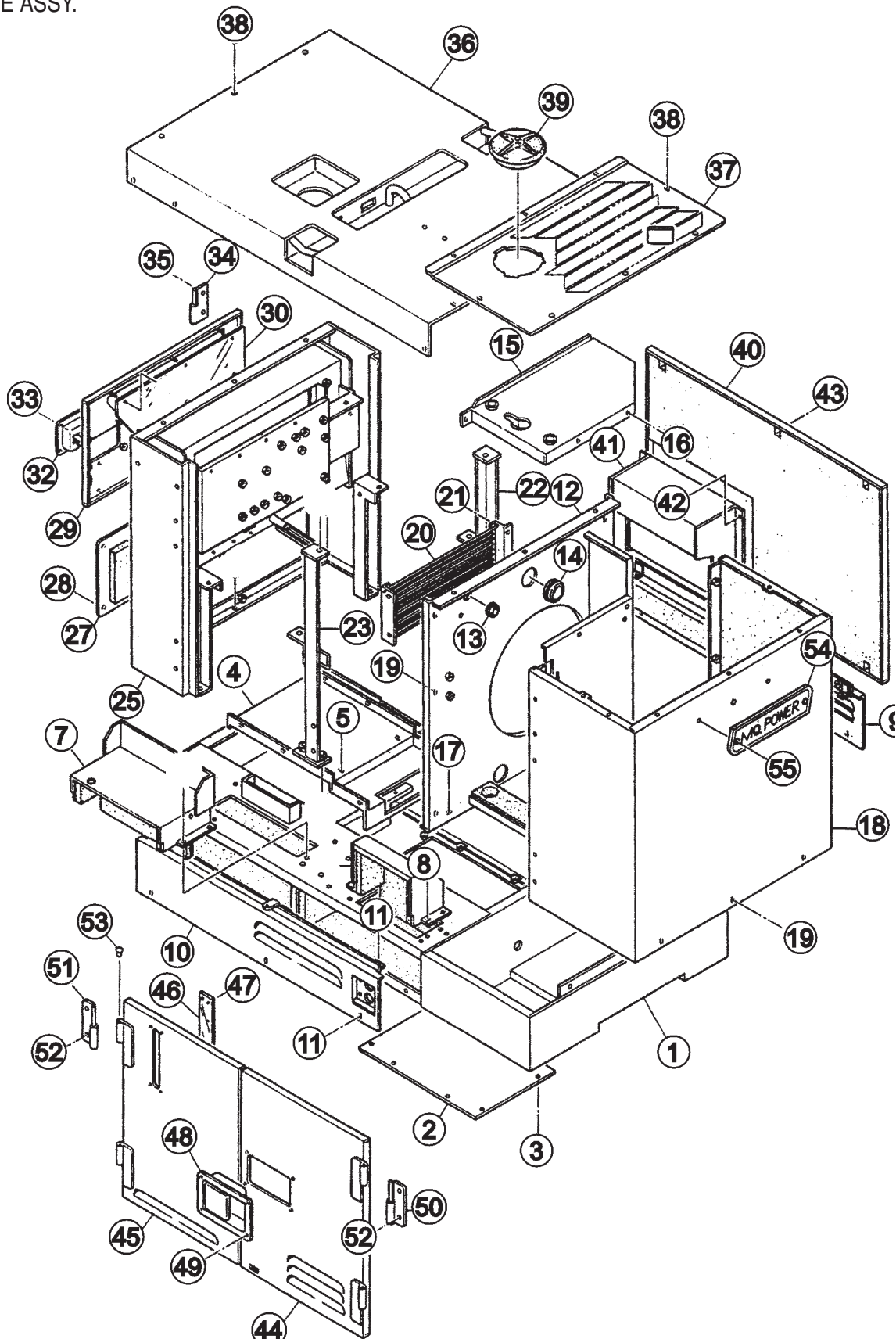

# TLG-12SPX --- ENCLOSURE ASSY.

ENCLOSURE ASSY.

<u>NO.</u>	<u>PART NO.</u>	<u>ITEM</u>	<u>QTY.</u>	<u>REMARKS</u>
1	8525110012	BASE	1	
	8525910003	ACOUSTIC SHEET	1	
2	8525110604	FLOOR PANEL	1	
3	0017106016	HEX. HEAD BOLT	8	
4	8525118003	PANEL	1	
	8525911004	ACOUSTIC SHEET	1	
5	0017106016	HEX. HEAD BOLT	8	
6	8525114003	DUCT	1	
	8525912004	ACOUSTIC SHEET	1	
7	8525115003	BATTERY FRAME	1	
	8525913004	ACOUSTIC SHEET	1	
8	0017106016	HEX. HEAD BOLT	8	
9	8525181103	SPLASHER PANEL	1	
	8525980004	ACOUSTIC SHEET	1	
10	8525181203	SPLASHER PANEL	1	
	8525980004	ACOUSTIC SHEET	1	
11	0017106016	HEX. HEAD BOLT	12	
12	8525120003	FRONT FRAME	1	
	8525920003	ACOUSTIC SHEET	1	
13	0601850239	GROMMET .....	2	B142
14	0601850253	GROMMET .....	2	B362
15	8525125003	DUCT COVER	1	
	8525922003	ACOUSTIC SHEET	1	
16	0017106016	HEX. HEAD BOLT	5	
17	011008020	HEX. HEAD BOLT .....	2	REPLACES 0017108020
18	8525121102	FRONT FRAME	1	
	8525921004	ACOUSTIC SHEET	1	
19	011008020	HEX. HEAD BOLT .....	9	REPLACES 0017108020
20	8522030003	FAN GUARD	1	
21	0017106016	HEX. HEAD BOLT	4	
22	8525132113	HANGER .....	1	S/N5107198 TO 5107225
	8525132223	HANGER .....	1	S/N5107226~
23	8525132013	HANGER .....	1	S/N5107198 TO 5107225
	8525132023	HANGER .....	1	S/N5107226~
24	0012312030	HEX. HEAD BOLT	6	

THE PART NUMBER DEFAULT IS SCARLET COLOR.  
INDICATE THE LETTERS BELOW TO INDICATE  
DIFFERENT COLOR OF UNIT:

MQW-WHITE

THE SERIAL NUMBER MAY BE REQUIRED.

# TLG-12SPX --- ENCLOSURE ASSY.

ENCLOSURE ASSY.

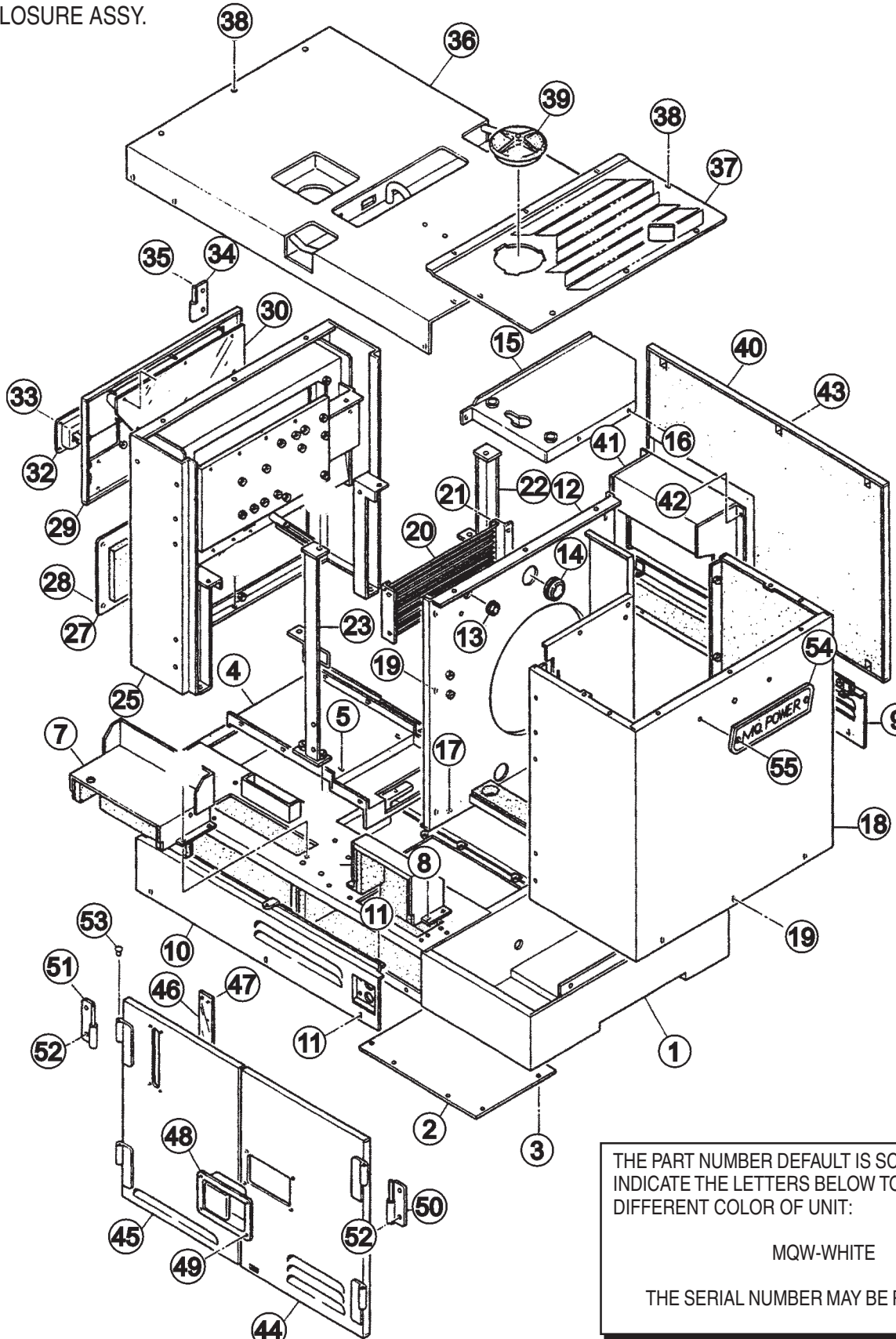

THE PART NUMBER DEFAULT IS SCARLET COLOR.  
INDICATE THE LETTERS BELOW TO INDICATE  
DIFFERENT COLOR OF UNIT:

MQW-WHITE

THE SERIAL NUMBER MAY BE REQUIRED.

ENCLOSURE ASSY.

<u>NO.</u>	<u>PART NO.</u>	<u>ITEM</u>	<u>QTY.</u>	<u>REMARKS</u>
25	8525141102	REAR FRAME .....	1 .....	S/N5107188 TO 5107225
	8525141112	REAR FRAME .....	1 .....	S/N5107226
26	011008020	HEX. HEAD BOLT .....	5 .....	REPLACES 0017108020
27	8525144104	COVER, REAR FRAME	1	
	8525940104	ACOUSTIC SHEET	1	
28	011008020	HEX. HEAD BOLT .....	6 .....	REPLACES 0017108020
29	8525145103	DOOR, REAR FRAME	1	
30	8525146104	WINDOW PLATE	1	
31	0207006000	HEX. NUT	6	
32	0605010230	DOOR HANDLE	1	
33	0021505012	MACHINE SCREW	4	
34	0810015204	HINGE	2	
	0810015504	WASHER	2	
35	0017106016	HEX. HEAD BOLT	4	
36	8525161002	ROOF PANEL .....	1 .....	S/N7107198 TO 7107225
	8525161012	ROOF PANEL .....	1 .....	S/N5107226
	8525960003	ACOUSTIC SHEET	1	
37	8525162004	ROOF COVER	1	
38	011008020	HEX. HEAD BOLT .....	17 .....	REPLACES 0017108020
39	1625165103	FILLER COVER	1	
40	8525172003	SIDE PANEL	1	
	8525971004	ACOUSTIC SHEET	1	
41	8525172103	DUCT	1	
	8525971004	ACOUSTIC SHEET	1	
42	0207006000	HEX. NUT	5	
43	0017108040	HEX. HEAD BOLT	6	
44	8525171203	SIDE DOOR	1	
	8525970103	ACOUSTIC SHEET	1	
45	8525171103	SIDE DOOR	1	
	8525970003	ACOUSTIC SHEET	1	
46	8525173004	WINDOW PLATE	1	
47	0027103010	MACHINE SCREW	4	
	0207003000	HEX. NUT	4	
48	0825007362	DOOR HANDLE	1	
49	0021805016	MACHINE SCREW	4	
50	M9110100304	HINGE .....	2 .....	REPLACES 0845047204
	0845045004	WASHER	2	
51	M9110100204	HINGE .....	2 .....	REPLACES 0845047104
	0845045004	SET WASHER	2	
52	011008020	HEX. HEAD BOLT .....	8 .....	REPLACES 0017108020
53	0845031304	CAP	4	
54	B9511200003	EMBLEM	1	
55	0021106020	MACHINE SCREW	2	

# TLG-12SPX --- RUBBER SEAL ASSY.

RUBBER SEAL ASSY.

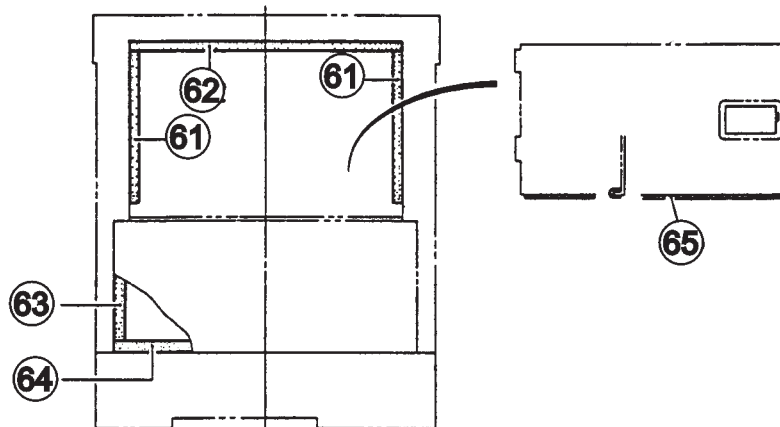
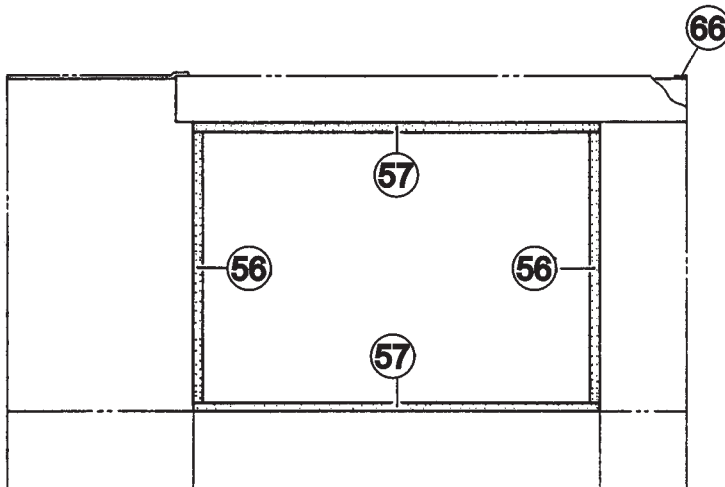
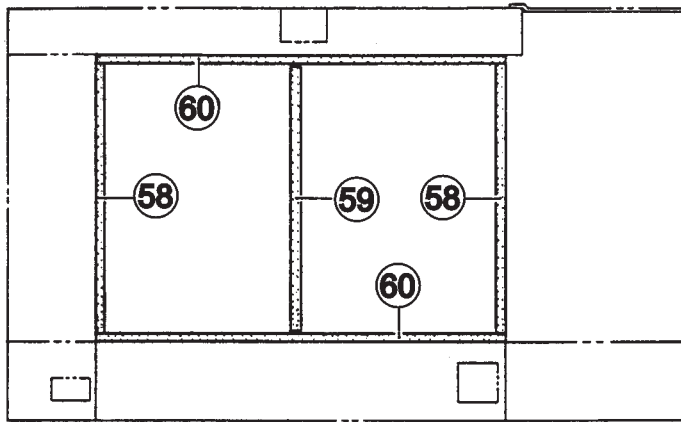



# TLG-12SPX --- RUBBER SEAL ASSY.

## RUBBER SEAL ASSY.

<u>NO.</u>	<u>PART NO.</u>	<u>ITEM</u>	<u>QTY.</u>	<u>REMARKS</u>
56	0227600590	RUBBER SEAL	2	
57	0227600835	RUBBER SEAL	2	
58	0229400560	RUBBER SEAL	2	
59	0229400550	RUBBER SEAL	1	
60	0229400840	RUBBER SEAL	2	
61	0229400220	RUBBER SEAL	2	
62	0229400590	RUBBER SEAL	1	
63	0229200210	RUBBER SEAL	2	
64	0229200615	RUBBER SEAL	2	
65	0226900570	RUBBER SEAL	1	
66	0229200680	RUBBER SEAL	1	

DECAL ASSY.

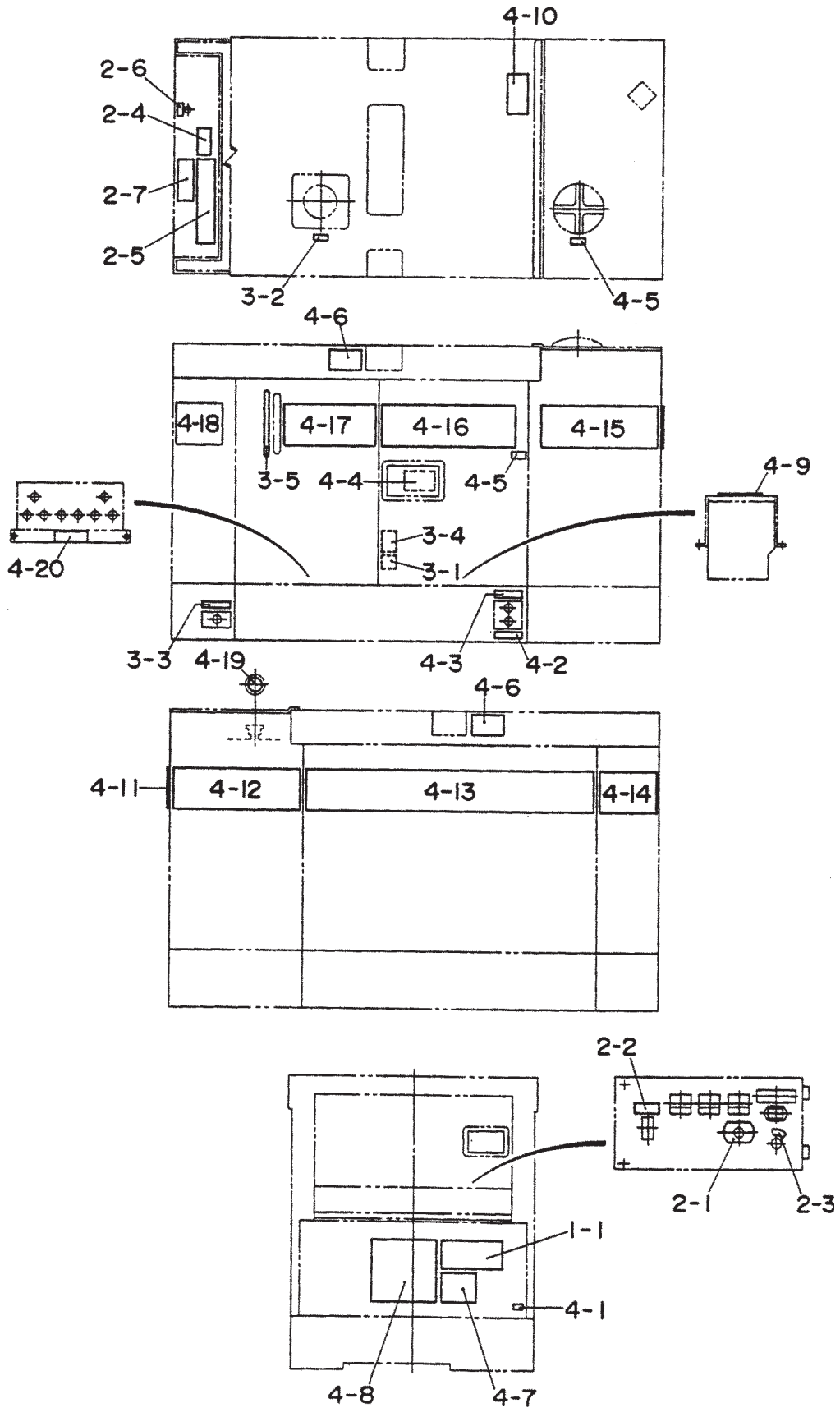

DECAL ASSY.

<u>NO.</u>	<u>PART NO.</u>	<u>ITEM</u>	<u>QTY.</u>	<u>REMARKS</u>
1-1	7440611013	DECAL; OPERATING PROCEDURE .....	1 .....	S1742B
2-1	7670623004	DECAL; VOLTAGE REGULATOR .....	1 .....	S3737
2-2	0840624504	DECAL; CIRCUIT BREAKER .....	1 .....	S-3031
2-3	8520621104	DECAL; STARTER SWITCH .....	1 .....	S4753
2-4	7670622004	DECAL; SPEED CONTROL HANDLE .....	1 .....	S3822
2-5	8520620203	DECAL; AC POWER OUTPUT .....	1 .....	S4754
2-6	7670624004	DECAL; GROUND .....	1 .....	S3821
2-7	8700611904	DECAL; DANGER .....	1 .....	S4985
3-1	1630610404	DECAL; CAUTION .....	1 .....	S1406
3-2	1320620904	DECAL; DIESEL FUEL .....	1 .....	S1756
3-3	7810680104	DECAL; FUEL DRAIN .....	1 .....	S3060
3-4	8520635004	DECAL; FUEL COCK .....	1 .....	S5068
3-5	8700615204	DECAL; FUEL GAUGE .....	1 .....	
4-1	0800628504	DECAL; GROUND .....	1 .....	S1123
4-2	1630645004	DECAL; OIL DRAIN .....	1 .....	S1403
4-3	1630647004	DECAL; COOLANT DRAIN .....	1 .....	S1404
4-4	1630610504	DECAL; CAUTION .....	1 .....	S1409
4-5	6360610304	DECAL; WATER .....	2 .....	S1880
4-6	1320621504	DECAL; SUPPORT HOOK .....	2 .....	S2257
4-7	6390671104	DECAL; IMPORTANT .....	1 .....	S2377
4-8	0840625902	DECAL; MQ .....	1 .....	S3057
4-9	8700611514	DECAL; WARNING .....	1 .....	S4926A
4-10	8700611804	DECAL; WARNING .....	1 .....	S4984
4-11	8520632003	STRIPE .....	1 .....	
4-12	8520632604	STRIPE .....	1 .....	
4-13	8520632504	STRIPE .....	1 .....	
4-14	8520632704	STRIPE .....	1 .....	
4-15	8520632104	STRIPE .....	1 .....	
4-16	8520632304	STRIPE .....	1 .....	
4-17	8520632404	STRIPE .....	1 .....	
4-18	8520632204	STRIPE .....	1 .....	
4-19	0600501103	DECAL; WARNING .....	1 .....	
4-20	0820650604	DECAL; DANGER .....	1 .....	

# ISUZU 3LB1 — CYLINDER HEAD COVER ASSY.

CYLINDER HEAD COVER ASSY.

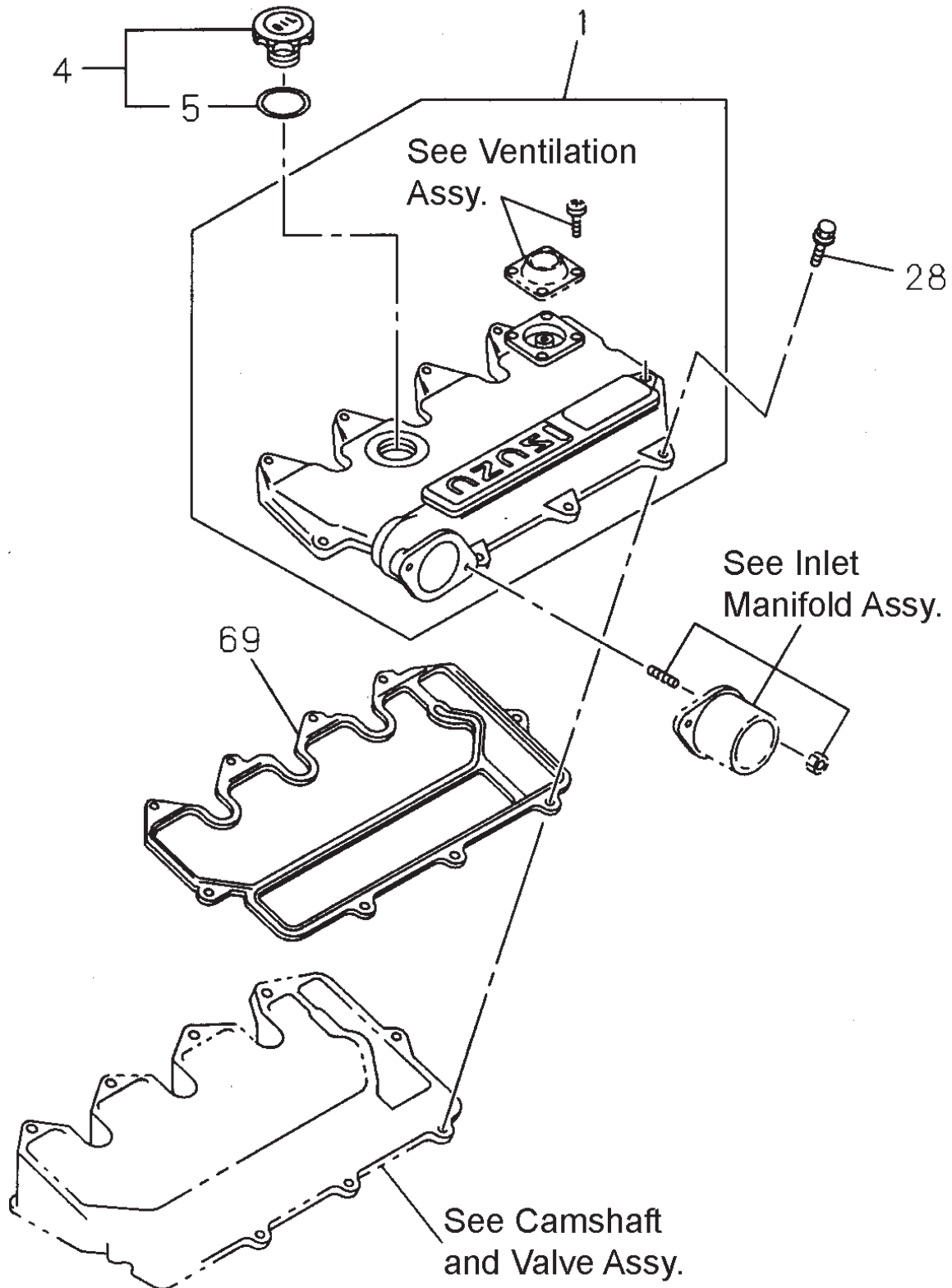

# ISUZU 3LB1 — CYLINDER HEAD COVER ASSY.

## CYLINDER HEAD COVER ASSY.

<u>NO</u>	<u>PART NO</u>	<u>PART NAME</u>	<u>QTY.</u>	<u>REMARKS</u>
1	8970655484	CYLINDER HEAD COVER	1	
4	8941332075	OIL FILLER CAP .....	1 .....	INCL. ITEMS W/*
5*	8941236231	OIL FILLER GASKET	1	
28	0280806200	BOLT	9	
69	8970655472	GASKET	1	

# ISUZU 3LB1 — CYLINDER HEAD ASSY.

CYLINDER HEAD ASSY.

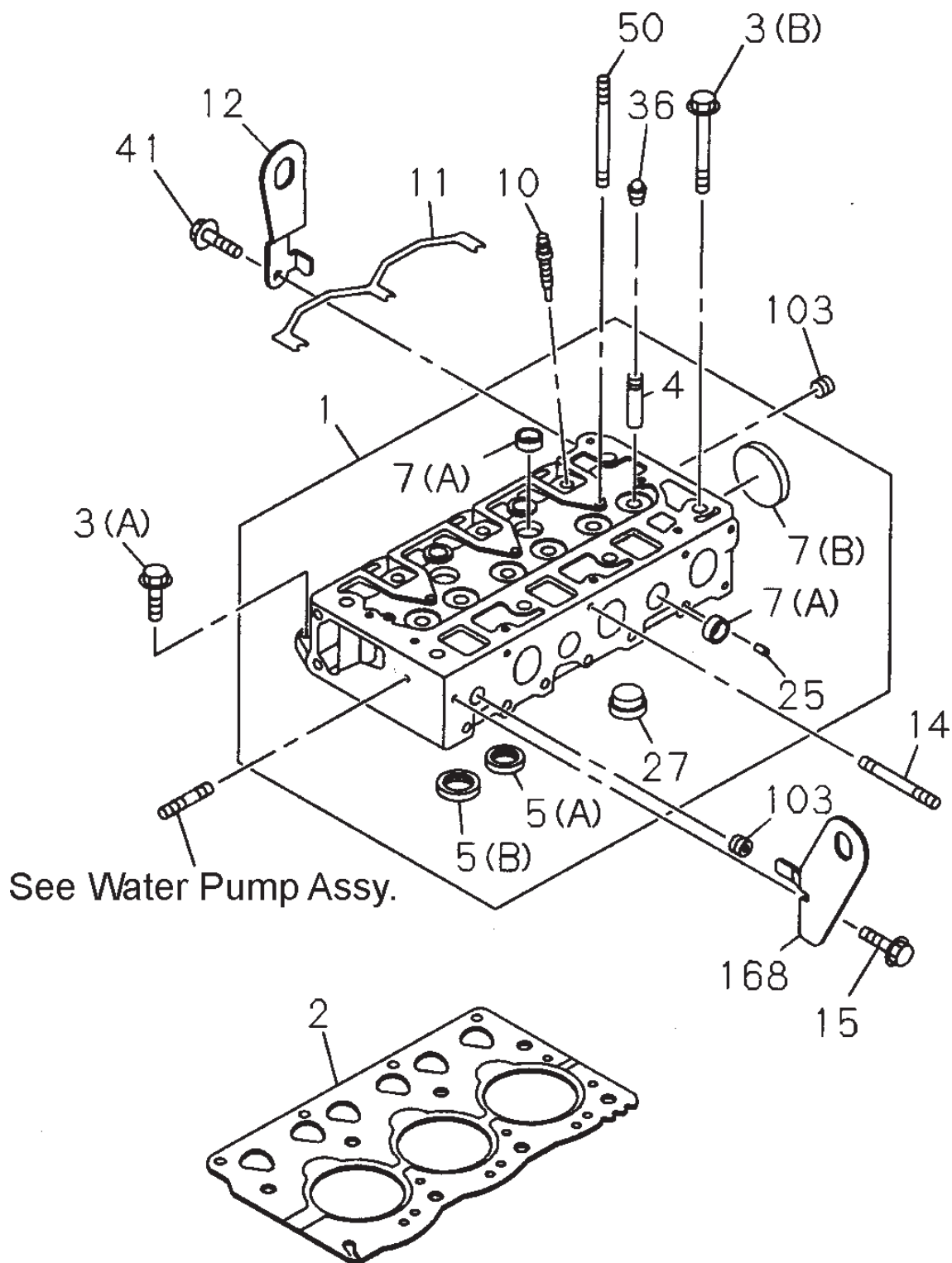

# ISUZU 3LB1 — CYLINDER HEAD ASSY.

## CYLINDER HEAD ASSY.

<u>NO</u>	<u>PART NO</u>	<u>PART NAME</u>	<u>QTY.</u>	<u>REMARKS</u>
1	8971056750	CYLINDER HEAD ASSY. ....	1	OCT. 1993 TO OCT. 1996; INCL. ITEMS W/*
	8971633991	CYLINDER HEAD ASSY. ....	1	NOV. 1996~
2	8970439332	GASKET	1	
3A	8944637840	BOLT	4	
3B	8970369591	BOLT	8	
4*	8970317490	VALVE GUIDE	6	
5A*	8970317101	VALVE INSERT SEAT	3	
5B*	8970317110	VALVE INSERT SEAT	3	
7A*	1096000112	SEALING CUP	4	
7B*	1096000051	SEALING CUP	1	
10	8971065490	GLOW PLUG	3	
11	8970346333	CONNECTOR	1	
12	8970853900	HANGER	1	
14	5093000650	EXHAUST MANIFOLD STUD	2	
15	028088160	BOLT	1	
25*	511190090	CYLINDER HEAD PLUG	4	
27*	8970446351	HOT PLUG	3	
36	8941105591	OIL SEAL	6	
41	0280808160	BOLT	1	
50	8970946410	ROCKER ARM STUD	5	
103	5096050050	PLUG	2	
168	8970853890	FRONT HANGER	1	

# ISUZU 3LB1 — CYLINDER BLOCK ASSY.

## CYLINDER BLOCK ASSY.

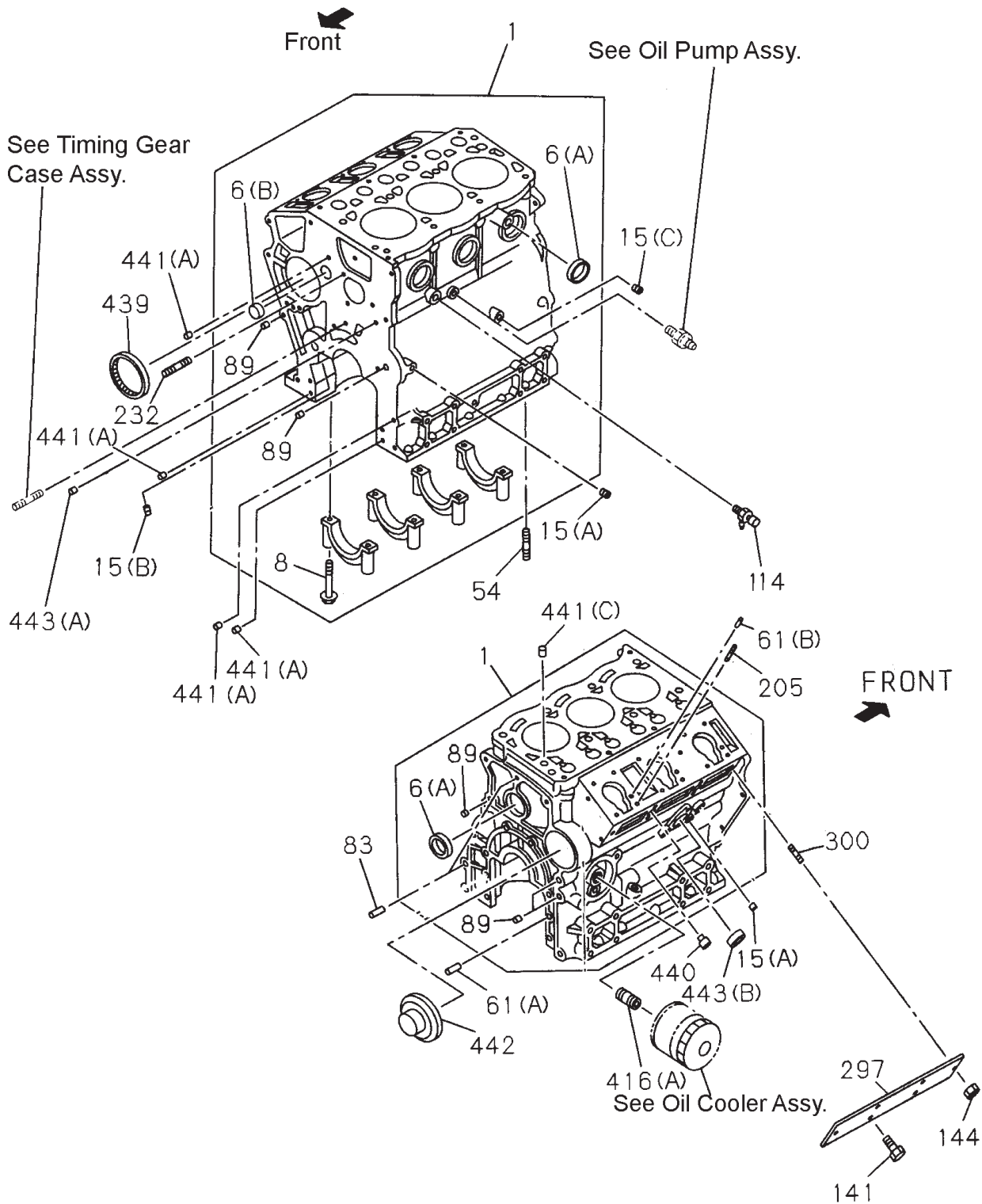



# ISUZU 3LB1 — CYLINDER BLOCK ASSY.

## CYLINDER BLOCK ASSY.

<u>NO.</u>	<u>PART NO.</u>	<u>PART NAME</u>	<u>QTY.</u>	<u>REMARKS</u>
1	8971061943	CYLINDER BLOCK ASSY.....	1	DEC. 1993 TO MAR. 1995; INCL. ITEMS W/*
	8971290721	CYLINDER BLOCK ASSY.....	1	APR. 1995 TO MAR. 1997
	8971691440	CYLINDER BLOCK ASSY.....	1	APR. 1997~
6A*	8942298530	SEALING CUP	4	
6B*	1096000112	SEALING CUP	1	
8*	8941674711	BOLT	8	
15A	1096050500	OIL GALLERY PLUG, PT 1/8	1	
15B	1096050040	OIL GALLERY PLUG, PT 1/8 SQ. HEAD	1	
15C	1096050190	OIL GALLERY PLUG, PT 1/4	1	
54	9041106160	OIL PAN STUD	2	
61A	9081606160	STRAIGHT PIN	2	
61B	9098785320	STRAIGHT PIN.....	3	REPLACES 9081606160
83	9081608160	FLYWHEEL PIN	2	
89*	5096000130	OIL GALLERY CUP	9	
114	5137210281	WATER DRAIN NIPPLE	1	
141	0280806140	BOLT, M6X16 FLANGE	4	
144	0911502060	NUT	2	
205	1093050050	STUD	6	
232	9041108400	WATER PUMP STUD	1	
297	8971062031	COVER	1	
300	9041106160	COVER STUD, M6X16 L=25	3	
	8943438960	COVER STUD, M6X19 L=27	1	
416	8943255950	OIL FILTER STUD	1	
439	8970470560	BEARING	1	
440	8970394953	PIN	2	
441A	9112290581	DOWEL, D=11	4	
441C	8942008190	DOWEL, D=15	2	
442	8970471421	THRUST PLUG	1	
443A	5096000130	SEALING CAP	1	
443B	1096000121	SEALING CAP	1	

# ISUZU 3LB1 — OIL PAN AND LEVEL GAUGE ASSY.

OIL PAN AND LEVEL GAUGE ASSY.

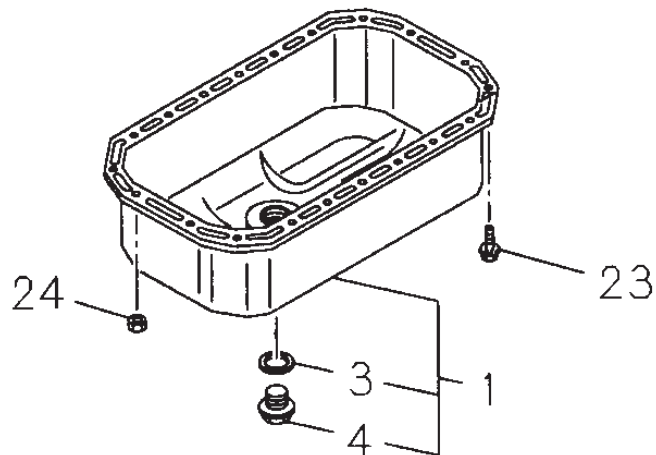
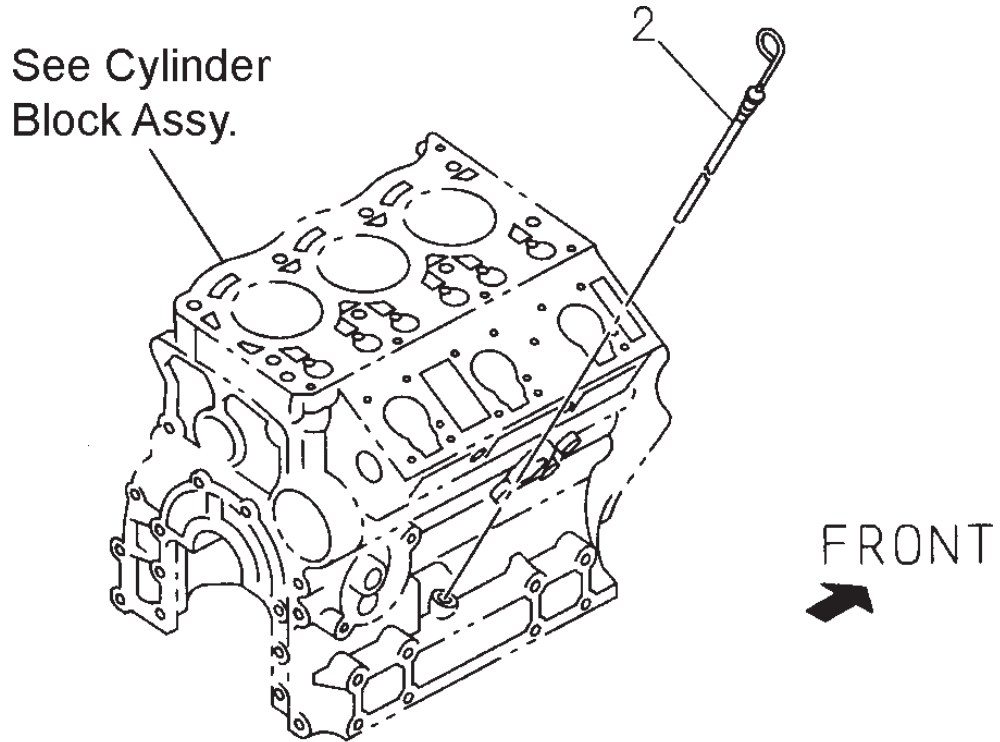

# ISUZU 3LB1 — OIL PAN AND LEVEL GAUGE ASSY.

## OIL PAN AND LEVEL GAUGE ASSY.

<u>NO.</u>	<u>PART NO.</u>	<u>PART NAME</u>	<u>QTY.</u>	<u>REMARKS</u>
1	8971322101	OIL PAN ASSY. ....	1 .....	REPLACES 8970439362; INCL .ITEMS W/*
2	8970439421	OIL LEVER GAUGE	1	
3*	1096230570	GASKET	1	
4*	9096620120	OIL DRAIN PLUG	1	
23	8971351410	BOLT .....	16 .....	REPLACES 0280806140
24	8971378360	OIL PAN NUT .....	2 .....	REPLACES 0911502060

# ISUZU 3LB1 — CAMSHAFT AND VALVE ASSY.

## CAMSHAFT AND VALVE ASSY.

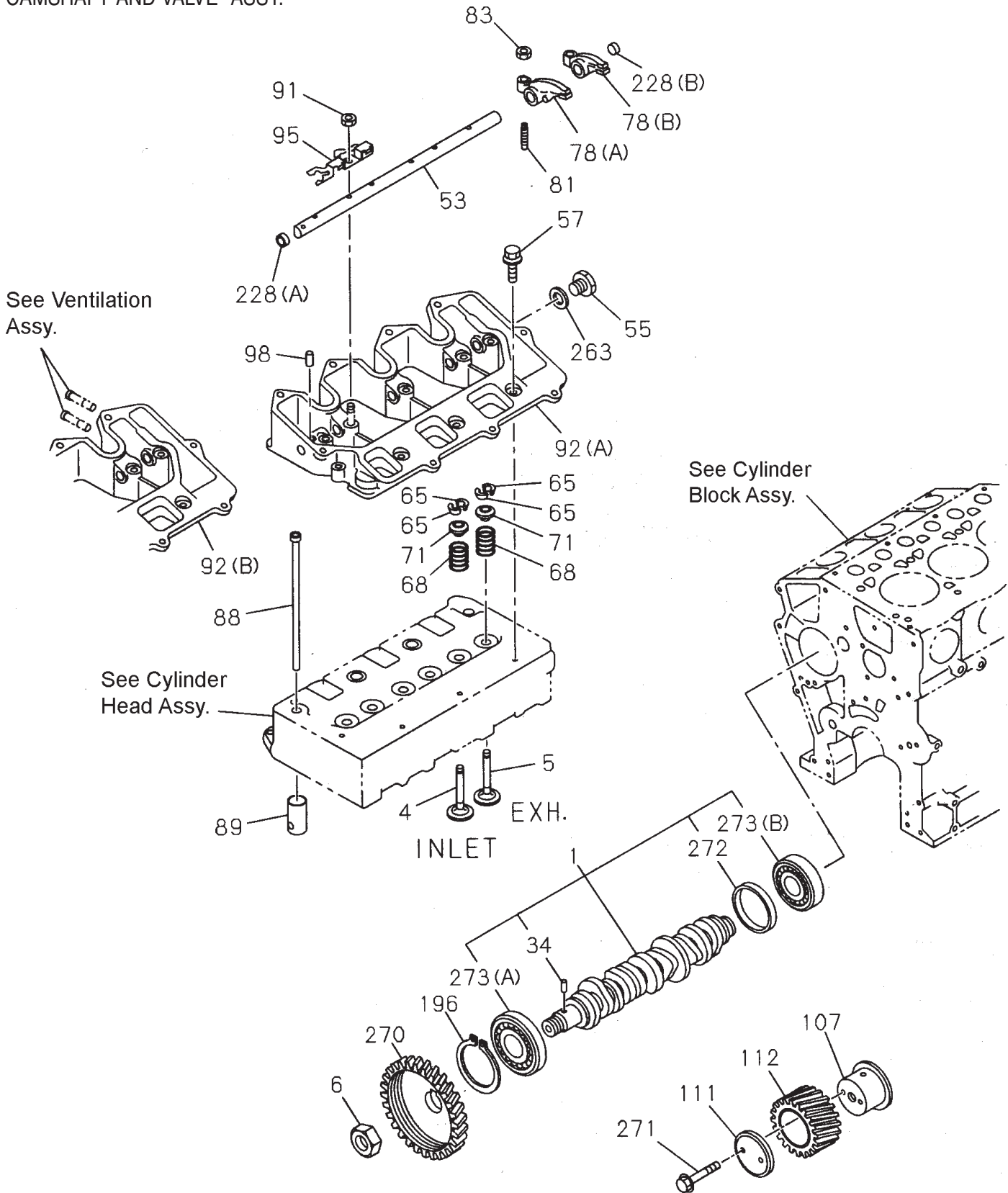

# ISUZU 3LB1 — CAMSHAFT AND VALVE ASSY.

## CAMSHAFT AND VALVE ASSY.

<u>NO.</u>	<u>PART NO.</u>	<u>PART NAME</u>	<u>QTY.</u>	<u>REMARKS</u>
1	8970621401	CAMSHAFT .....	1 .....	INCL. ITEMS W/*
4	8971021240	INLET VALVE	3	
5	8970346283	EXHAUST VALVE	3	
6	5094000530	NUT	1	
34*	9098786260	PIN	1	
53	8970668721	ROCKER ARM SHAFT	1	
55	9992023140	PLUG	1	
57	0280806250	BOLT, M6X25 FLANGE	4	
	0286806160	BOLT, M6X16	4	
65	8942395010	SPLIT COLLAR	12	
68	8970346291	VALVE SPRING	6	
71	8942510311	SPRING SEAT	6	
78A	8970668761	ROCKER ARM, INLET .....	3 .....	APR. 1992 TO SEP. 1992
	8972125180	ROCKER ARM, INLET .....	3 .....	OCT. 1992~; REPLACES 8971164480
78B	8970668781	ROCKER ARM, EXHAUST .....	3 .....	APR. 1992 TO SEP. 1992
78B	8972125200	ROCKER ARM, EXHAUST .....	3 .....	OCT. 1992~; REPLACES 8971164500
81	8970104850	SCREW	6	
83	9091115060	NUT	6	
88	8970668692	PUSH ROD	6	
89	8971243690	VALVE TAPPET .....	6 .....	REPLACES 8970346301
91	0911502060	NUT	5	
92A	8971056791	ROCKER ARM BRACKET .....	1 .....	OCT. 1993 TO MAY 1995
	8971312450	ROCKER ARM BRACKET .....	1 .....	JUN. 1995 TO OCT. 1995
92B	8971634112	ROCKER ARM BRACKET	1	
95	8970698871	ROCKER SHAFT SPRING	3	
98	9081605160	SHAFT PIN .....	1 .....	REPLACES 9096785100
107	8971297800	IDLE GEAR SHAFT .....	1 .....	REPLACES 8970728290
111	5125350051	COLLAR	1	
112	8970375940	IDLER GEAR .....	1 .....	APR. 1992 TO SEP. 1995
	8971297820	IDLER GEAR .....	1 .....	OCT. 1995~
196	9091801620	SNAP RING	1	
228A	9111290830	SEALING CUP	1	
228B	8970395260	SEALING CUP	1	
263	9095714140	GASKET	1	
270	8971022880	INJECTION PUMP GEAR	1	
271	0280908600	BOLT .....	2 .....	APR. 1992 TO SEPT. 1995
	0280908450	BOLT .....	2 .....	OCT. 1995~
272*	8970620480	CAMSHAFT RING	1	
273A*	9000906100	CAMSHAFT BEARING	1	
273B*	9000906570	CAMSHAFT BEARING	1	

# ISUZU 3LB1 — CRANKSHAFT, PISTON AND FLYWHEEL ASSY.

CRANKSHAFT, PISTON AND FLYWHEEL ASSY.

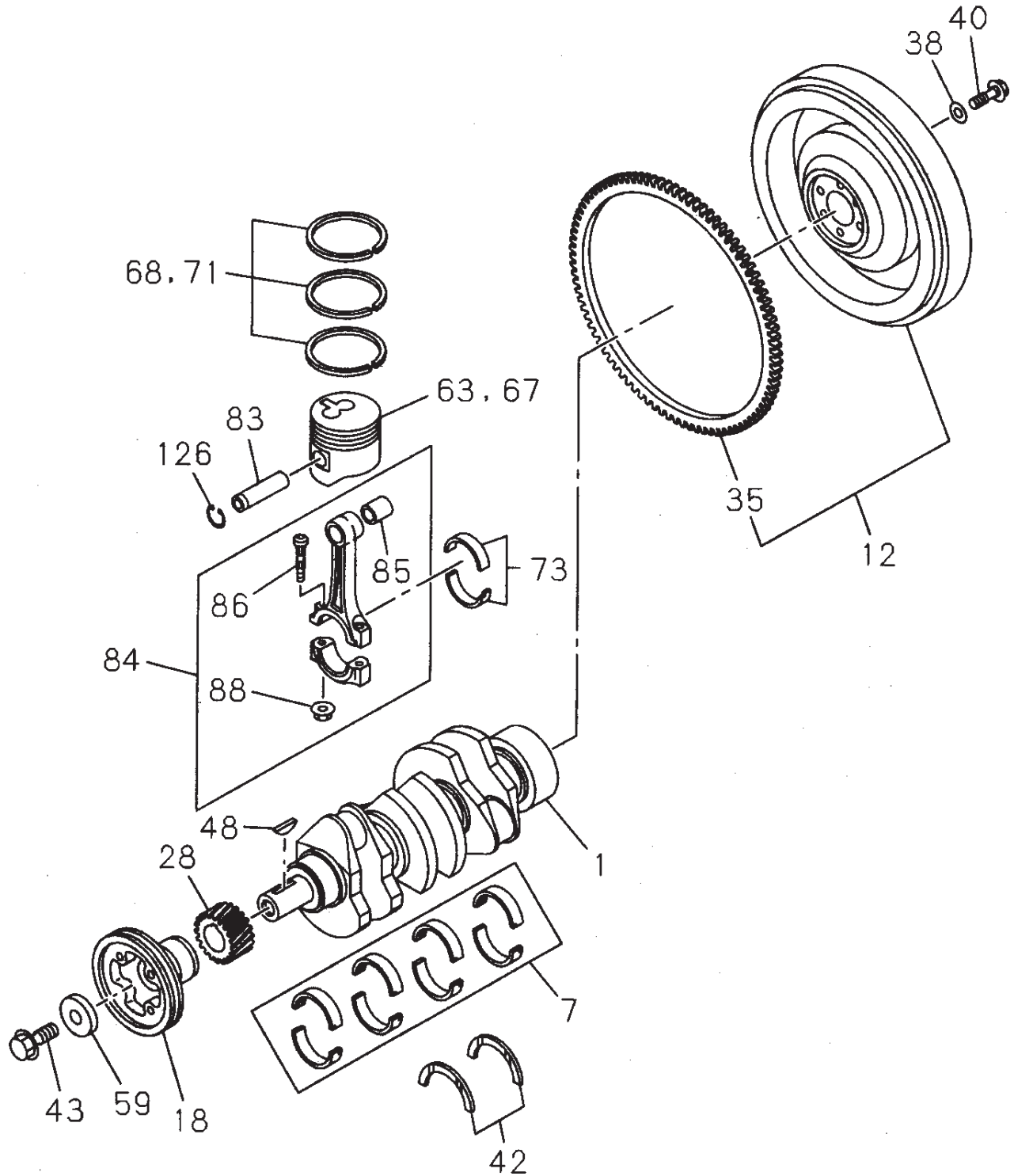

# ISUZU 3LB1 — CRANKSHAFT, PISTON AND FLYWHEEL ASSY.

## CRANKSHAFT, PISTON AND FLYWHEEL ASSY.

<u>NO</u>	<u>PART NO</u>	<u>PART NAME</u>	<u>QTY.</u>	<u>REMARKS</u>
1	8970405203	CRANKSHAFT	1	
7	8970395820	METAL KIT	1	
12	8971078930	FLYWHEEL .....	1	INCL. ITEM W/*
18	8971093721	PULLEY	1	
28	8970345920	GEAR	1	
35*	8944196021	RING GEAR	1	
38	8970232680	WASHER	6	
40	8941333281	BOLT	6	
42	5115990023	WASHER	2	
43	8943860790	BOLT	1	
48	8942016410	WOODRUFF KEY	1	
59	8941347920	WASHER	1	
63	8971768880	PISTON	3	
67	8970871050	PISTON, O/S=0.25	3	
68	8970346090	RING SET .....	3	APR. 1992 TO SEP. 1995
	8971137620	RING SET .....	3	OCT. 1995~
71	8971412040	RING SET, O/X=0.25	3	
73	5122710141	METAL SET	3	
83	8944017510	PISTON PIN	3	
84	8970200670	CONNECTOR ROD ASSY. ....	3	INCL. ITEMS W/#
85#	8941375220	BUSHING	3	
86#	8941075501	BOLT	6	
88#	8942409020	NUT	6	
126	8944017501	SNAP RING	6	

# ISUZU 3LB1 — TIMING GEAR AND FLYWHEEL HOUSING ASSY.

## TIMING GEAR AND FLYWHEEL HOUSING ASSY.

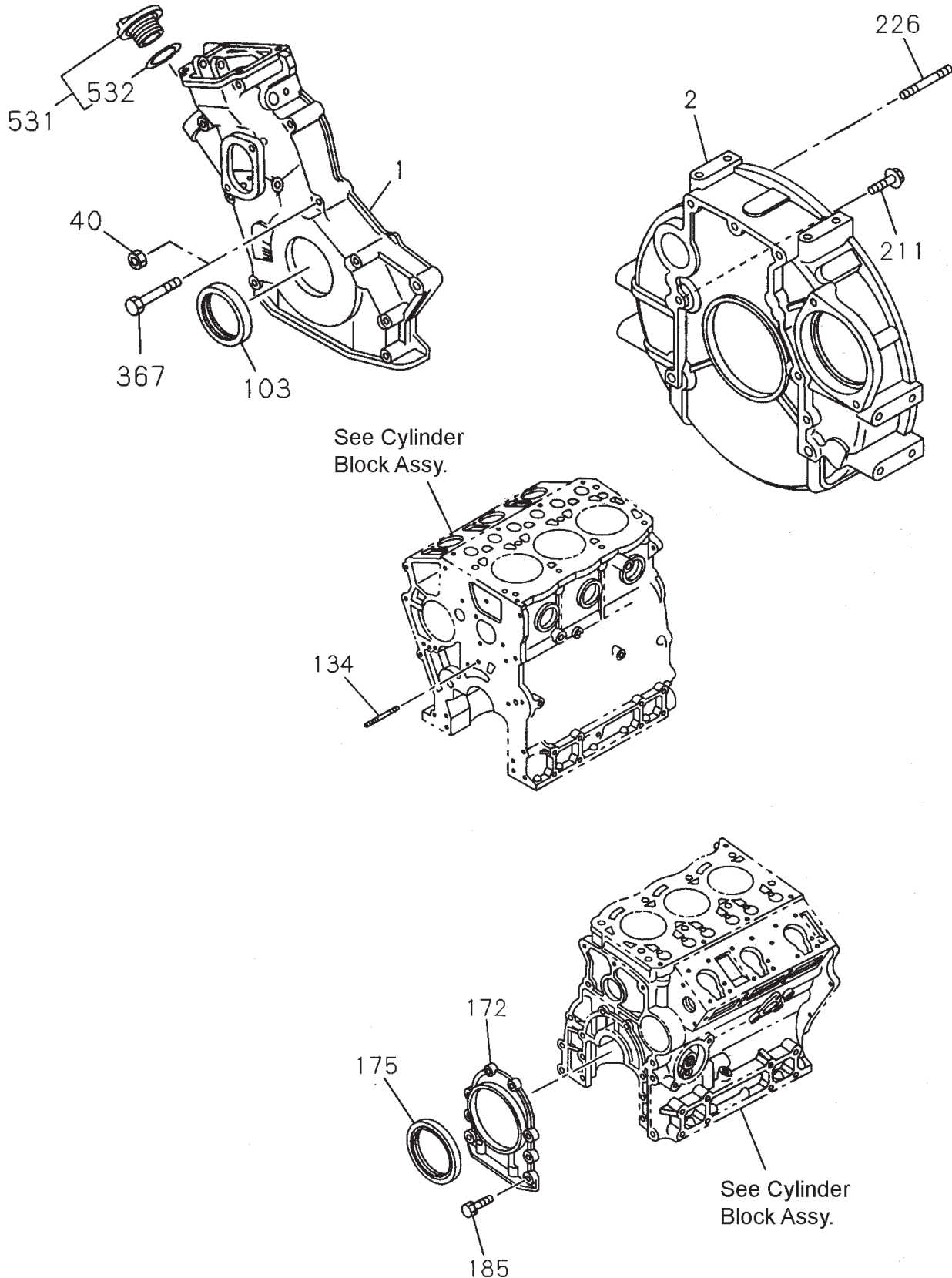



# ISUZU 3LB1 — TIMING GEAR AND FLYWHEEL HOUSING ASSY.

## TIMING GEAR AND FLYWHEEL HOUSING ASSY.

<u>NO.</u>	<u>PART NO.</u>	<u>PART NAME</u>	<u>QTY.</u>	<u>REMARKS</u>
1	8970851331	TIMING GEAR CASE	1	
2	8970470233	FLYWHEEL HOUSING	1	
40	0911502080	NUT	2	
103	5096250790	SEAL	1	
134	9041108600	STUD, M8X60 L=72	1	
	9041108500	STUD, M8X50 L=62	1	
172	8970447862	RETAINER	1	
175	5096250940	OIL SEAL	1	
185	0280806200	BOLT	6	
211	0281810250	BOLT	4	
226	8941277030	STUD	2	
367	0280808800	BOLT, M8X80 FLANGE	2	
	0280908600	BOLT, M8X60 FLANGE	6	
531	8944256852	OIL FILLER CAP .....	1 .....	INCL. ITEM W/*
532*	8941236231	CAP GASKET	1	

# ISUZU 3LB1 — INLET MANIFOLD ASSY.

INLET MANIFOLD ASSY.

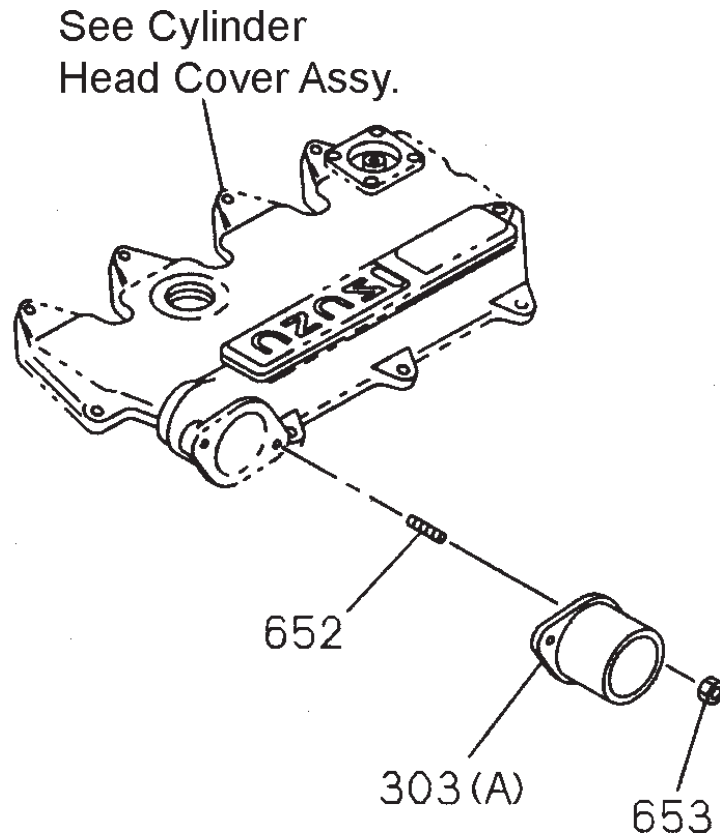

# ISUZU 3LB1 — INLET MANIFOLD ASSY.

## INLET MANIFOLD ASSY.

<u>NO.</u>	<u>PART NO.</u>	<u>PART NAME</u>	<u>QTY.</u>	<u>REMARKS</u>
303	8970346140	AIR PIPE	1	
652	9041106160	DUCT STUD	2	
653	0911502060	NUT	2	

# ISUZU 3LB1 — EXHAUST MANIFOLD ASSY.

EXHAUST MANIFOLD ASSY.

See Cylinder  
Head Assy.

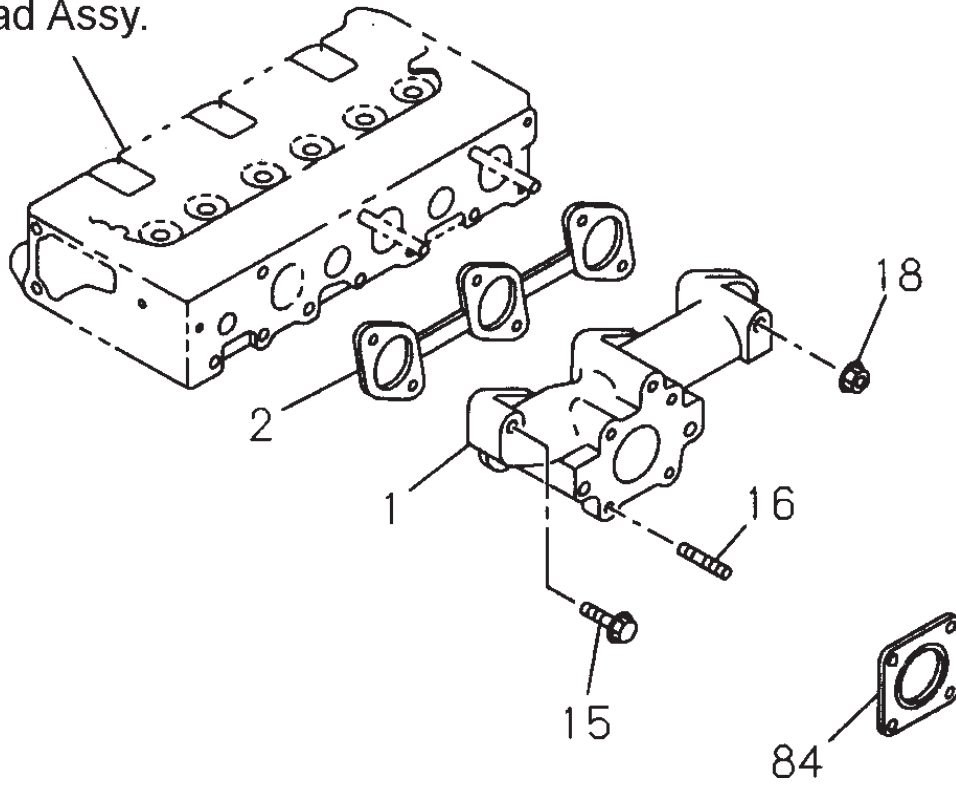

# ISUZU 3LB1 — EXHAUST MANIFOLD ASSY.

## EXHAUST MANIFOLD ASSY.

<u>NO.</u>	<u>PART NO.</u>	<u>PART NAME</u>	<u>QTY.</u>	<u>REMARKS</u>
1	8970345881	EXHAUST MANIFOLD	1	
2	8970376822	GASKET	1	
15	0280808400	BOLT, M8X40 FLANGE	1	
	0280808700	BOLT, M8X70 FLANGE	1	
16	9041108200	STUD	4	
18	0911502080	NUT	2	
84	8970420280	GASKET, EXHAUST PIPE	1	

# ISUZU 3LB1 — VENTILATION ASSY.

## VENTILATION ASSY.

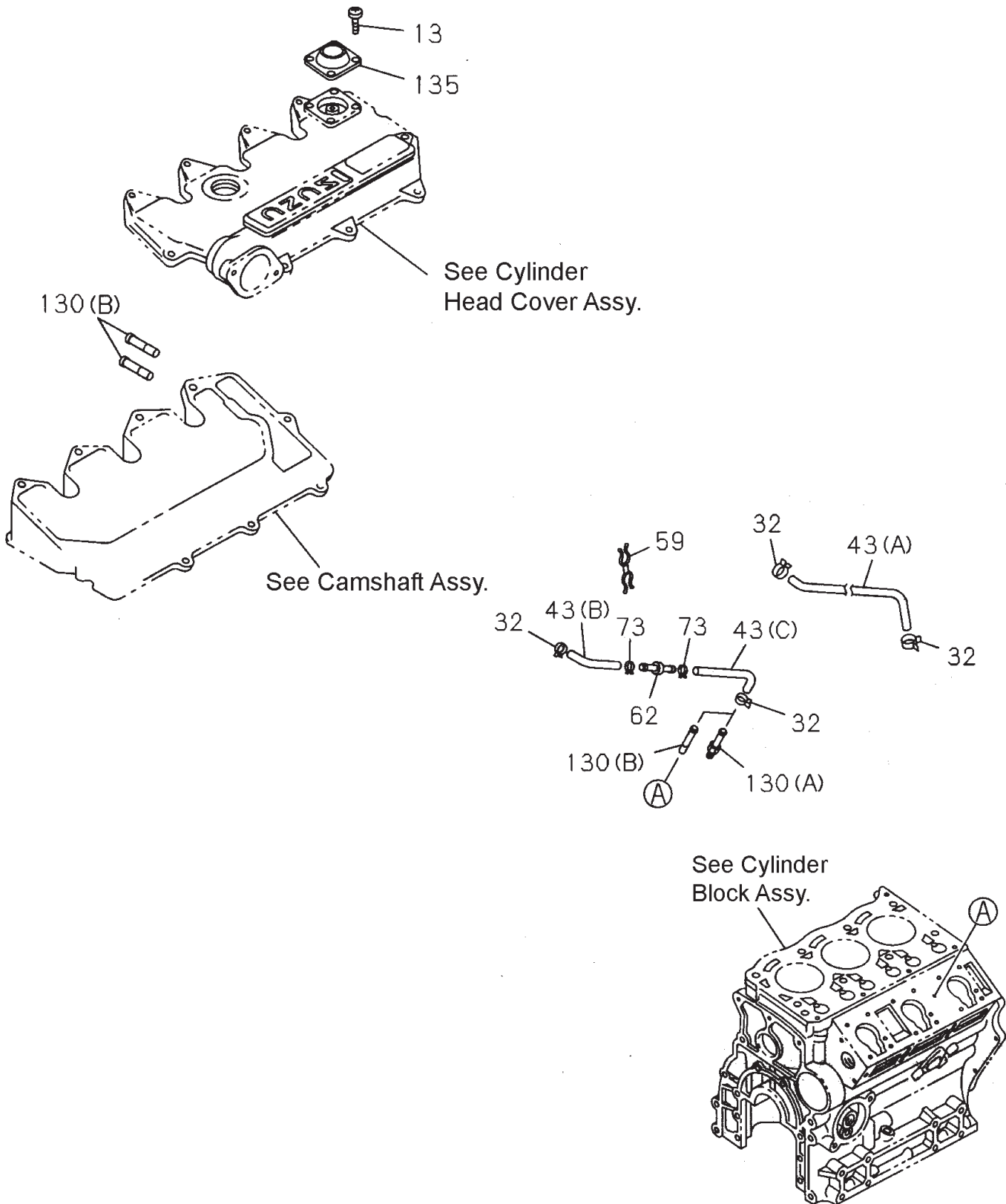

# ISUZU 3LB1 — VENTILATION ASSY.

## VENTILATION ASSY.

<u>NO.</u>	<u>PART NO.</u>	<u>PART NAME</u>	<u>QTY.</u>	<u>REMARKS</u>
13	9039104100	SCREW	4	
32	5097070051	CLIP	4	
43A	8971056801	PCV HOSE	1	
43B	8971025191	PCV HOSE	1	
43C	8971056811	PCV HOSE .....	1 .....	OCT. 1993 TO OCT. 1997
	8971025191	PCV HOSE .....	1 .....	NOV. 1997~
59	8941271440	HOSE CLIP	1	
62	8942493171	CHECK VALVE	1	
73	8942386100	CHECK VALVE CLIP .....	1 .....	OCT. 1993 TO OCT. 1997
	1097070870	CHECK VALVE CLIP .....	1 .....	NOV. 1997~
130A	8970833300	PCV PIPE	1	
130B	5111790520	PCV PIPE	3	
135	8943295490	VENTILATOR ASSY.	1	

# ISUZU 3LB1 — WATER PUMP AND CORROSION RESISTOR ASSY.

WATER PUMP AND CORROSION RESISTOR ASSY.

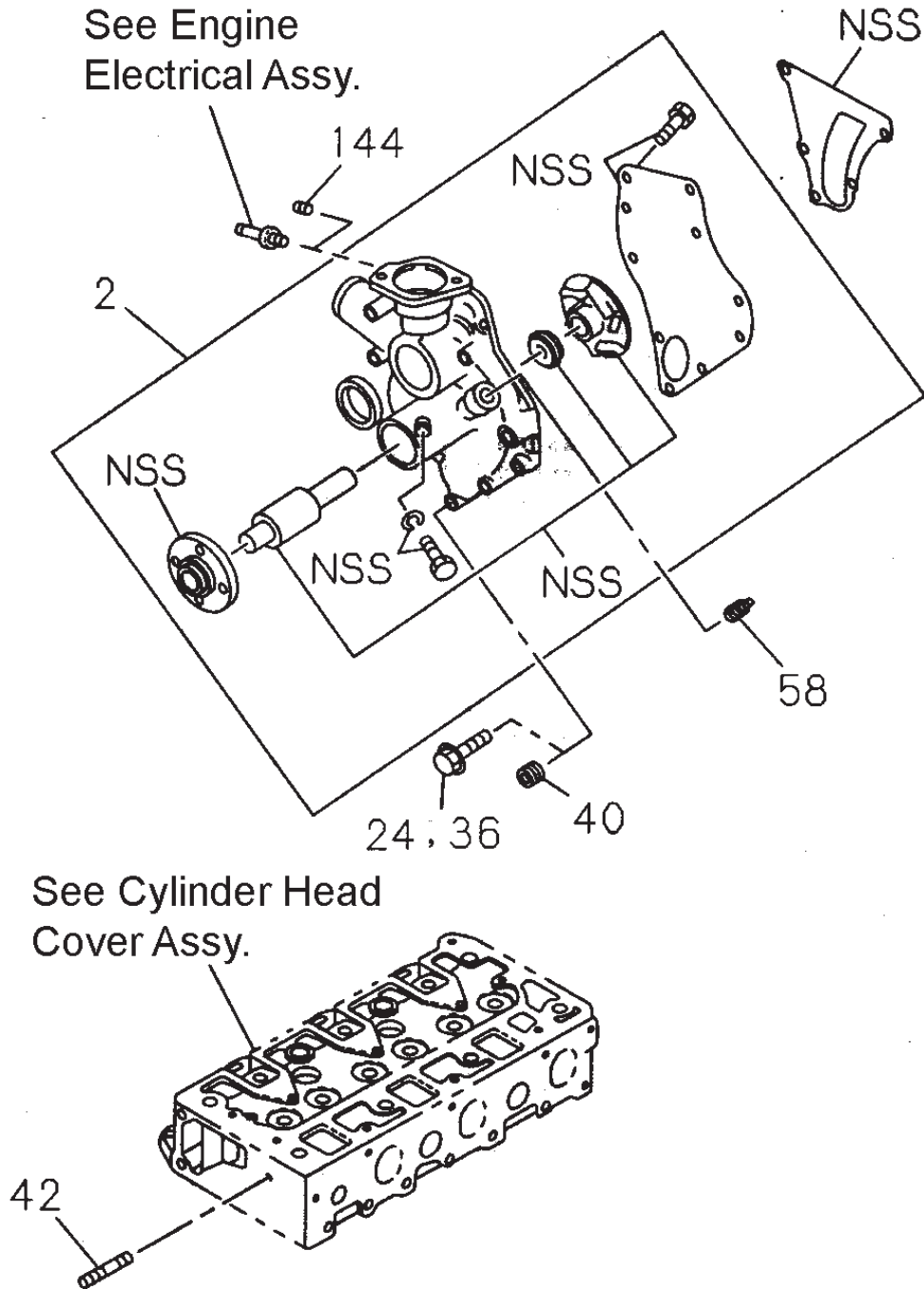



# ISUZU 3LB1 — WATER PUMP AND CORROSION RESISTOR ASSY.

## WATER PUMP AND CORROSION RESISTOR ASSY.

<u>NO.</u>	<u>PART NO.</u>	<u>PART NAME</u>	<u>QTY.</u>	<u>REMARKS</u>
2	8971632590	WATER PUMP ASSY. ....	1 .....	REPLACES 8970698821
24	0280808450	BOLT, M8X45 FLANGE	1	
36	0280908600	BOLT, M8X60 FLANGE	2	
	0280808400	BOLT, M8X40 FLANGE	2	
40	0911502080	NUT	2	
42	9041108400	STUD	1	
58	5096050050	HEATER PLUG	1	
144	1096050500	THERMOSTAT PLUG	1	

# ISUZU 3LB1 — THERMOSTAT AND HOUSING ASSY.

THERMOSTAT AND HOUSING ASSY.

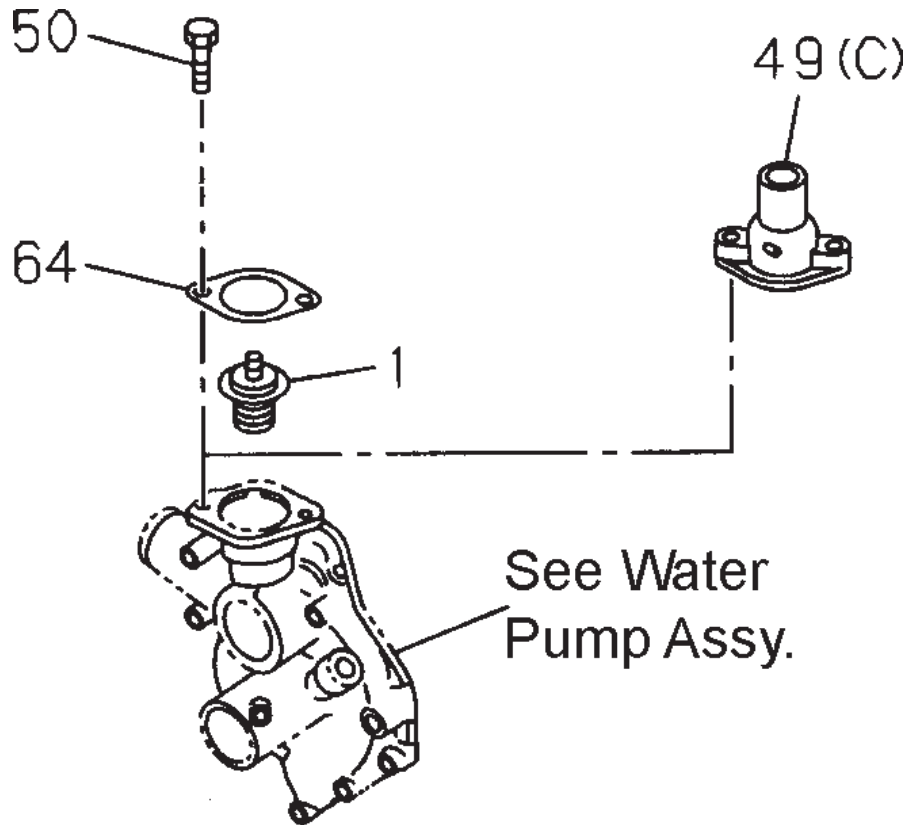

# ISUZU 3LB1 — THERMOSTAT AND HOUSING ASSY.

## THERMOSTAT AND HOUSING ASSY.

<u>NO.</u>	<u>PART NO.</u>	<u>PART NAME</u>	<u>QTY.</u>	<u>REMARKS</u>
1	8943255131	THERMOSTAT .....	1 .....	APR. 1992 TO DEC. 1996
	8971606540	THERMOSTAT .....	1 .....	JAN. 1997~
49	8970958411	WATER OUTLET PIPE	1	
50	0280808200	BOLT	2	
64	8943259561	GASKET	1	

# ISUZU 3LB1 — FAN AND FAN BELT ASSY.

FAN AND FAN BELT ASSY.

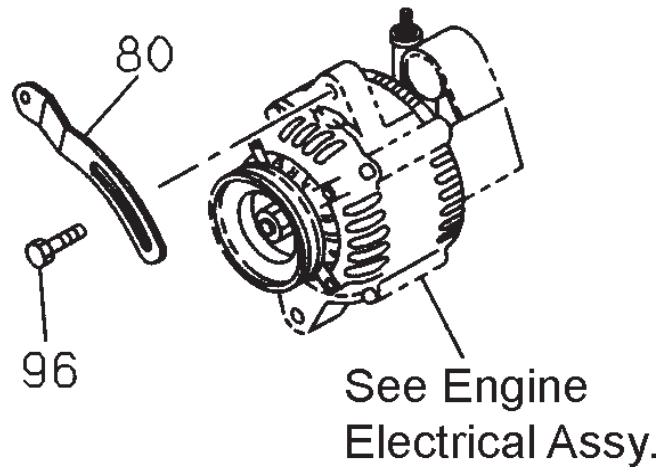
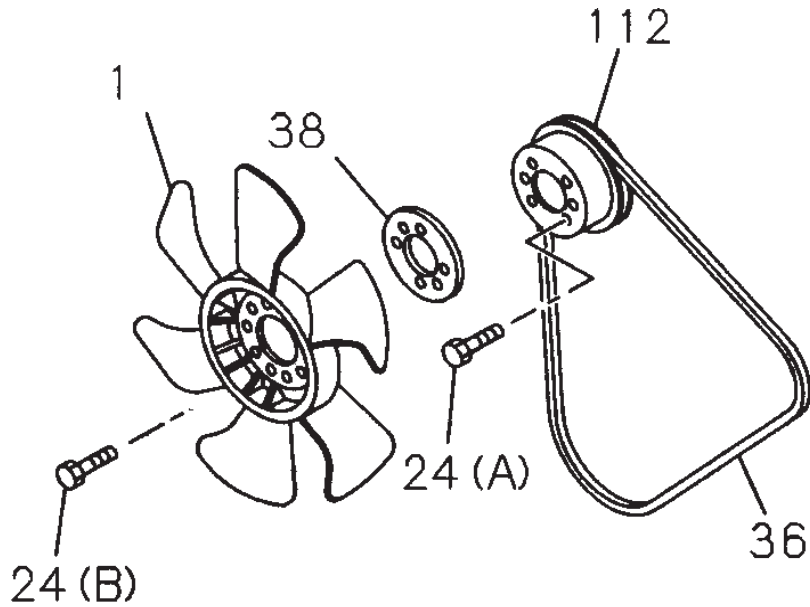

# ISUZU 3LB1 — FAN AND FAN BELT ASSY.

## FAN AND FAN BELT ASSY.

<u>NO.</u>	<u>PART NO.</u>	<u>PART NAME</u>	<u>QTY.</u>	<u>REMARKS</u>
1	8970967090	COOLING FAN .....	1 .....	D=330-6-BLOW
24A	0208006120	BOLT, M6X12	2	
24B	0280808220	BOLT, M8X22 FLANGE	4	
36	8970407640	BELT, L=826 .....	1 .....	APR. 1992 TO AUG. 1996
	8971604370	BELT, L=815 .....	1 .....	SEPT. 1996~
38	8970634001	FAN SPACER	1	
80	5136741040	ADJUSTMENT PLATE	1	
96	0280808200	BOLT	1	
112	8970384030	PULLEY, 1-GROOVE	1	

# ISUZU 3LB1 — FUEL INJECTION ASSY.

## FUEL INJECTION ASSY.

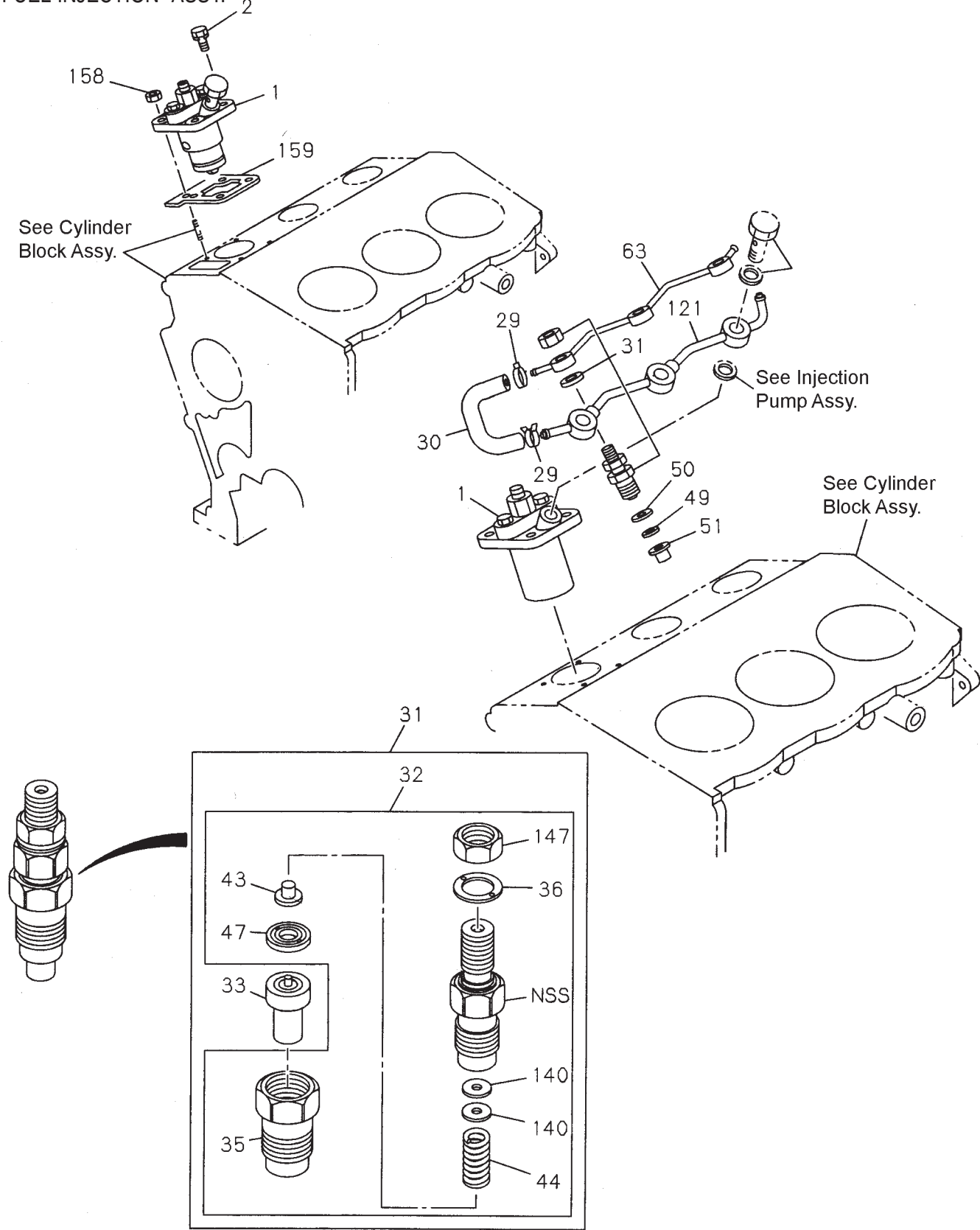

# ISUZU 3LB1 — FUEL INJECTION ASSY.

## FUEL INJECTION ASSY.

<u>NO.</u>	<u>PART NO.</u>	<u>PART NAME</u>	<u>QTY.</u>	<u>REMARKS</u>
1	8970345915	INJECTION PUMP ASSY.	3	
2	0280808200	BOLT	6	
29	5097070051	CLIP	2	
30	8970408090	RUBBER HOSE	1	
31	8970799760	NOZZLE ASSY. ....	3	INCL. ITEMS W/*
32*	8970908420	HOLDER ASSY. ....	3	INCL. ITEMS W/#
33*	8941305320	NOZZLE	3	
35*#	8970846170	NUT	3	
36*#	8941049930	GASKET	3	
43*#	8941289630	SEAT	3	
44*#	8941289640	SPRING	3	
47*#	8970833580	SPACER	3	
49	8941060403	WASHER	3	
50	8942575920	GASKET	3	
51	8941060551	SHIELD	3	
63	8970346261	PIPE	1	
121	8970964020	FUEL PIPE	1	
140*#	8941769620	SHIM .....	1	T=0.1
	8941769630	SHIM .....	1	T=0.2
	8941769640	SHIM .....	1	T=0.3
	8941769650	SHIM .....	1	T=0.4
	8941769660	SHIM .....	1	T=0.5
	8941769670	SHIM .....	1	T=0.52
	8941769680	SHIM .....	1	T=0.54
	8941769690	SHIM .....	1	T=0.56
	8941769700	SHIM .....	1	T=0.58
	8941769710	SHIM .....	1	T=0.6
147*#	8941290060	NUT	3	
158	0911502080	NUT	6	
159	8971263560	INJ. SHIM .....	1	T=0.2; REPLACES 8970346152
	8971263570	INJ. SHIM .....	1	T=0.3; REPLACES 8970346162
	8971263580	INJ. SHIM .....	1	T=0.4; REPLACES 8970346172
	8971263590	INJ. SHIM .....	1	T=0.5; REPLACES 8970346182
	8971263600	INJ. SHIM .....	1	T=0.6; REPLACES 8970346192
	8971263610	INJ. SHIM .....	1	T=0.7; REPLACES 8970346202
	8971263620	INJ. SHIM .....	1	T=0.8; REPLACES 8970346212
	8971263630	INJ. SHIM .....	1	T=1.0; REPLACES 897034622
	8971263640	INJ. SHIM .....	1	T=1.2; REPLACES 8970346232

# ISUZU 3LB1 — FUEL FILTER AND BRACKET ASSY.

FUEL FILTER AND BRACKET ASSY.

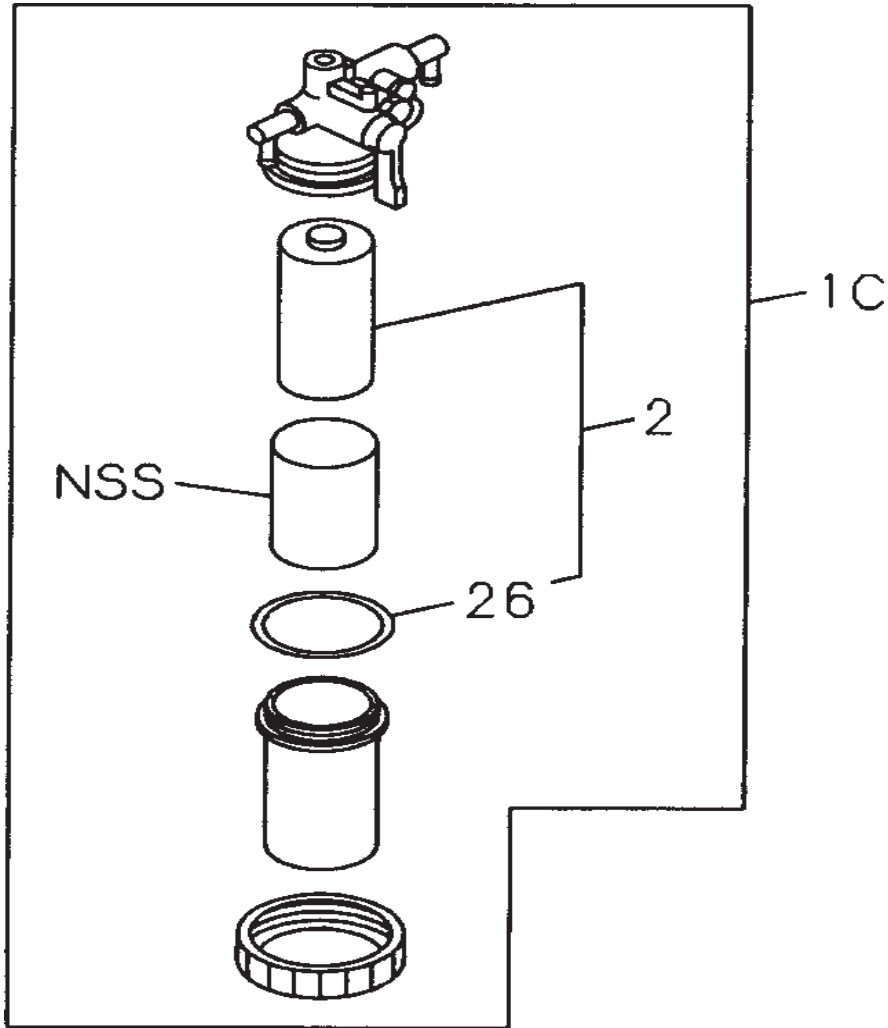



# ISUZU 3LB1 — FUEL FILTER AND BRACKET ASSY.

FUEL FILTER AND BRACKET ASSY.

<u>NO.</u>	<u>PART NO.</u>	<u>PART NAME</u>	<u>QTY.</u>	<u>REMARKS</u>
1	8971041891	FUEL FILTER ASSY. ....	1 .....	INCL. ITEMS W/*
2*	8970713480	FUEL FILTER ELEMENT KIT	1	
26*	8941551830	GASKET	1	

# ISUZU 3LB1 — FUEL PUMP AND PIPE ASSY.

FUEL PUMP AND PIPE ASSY.

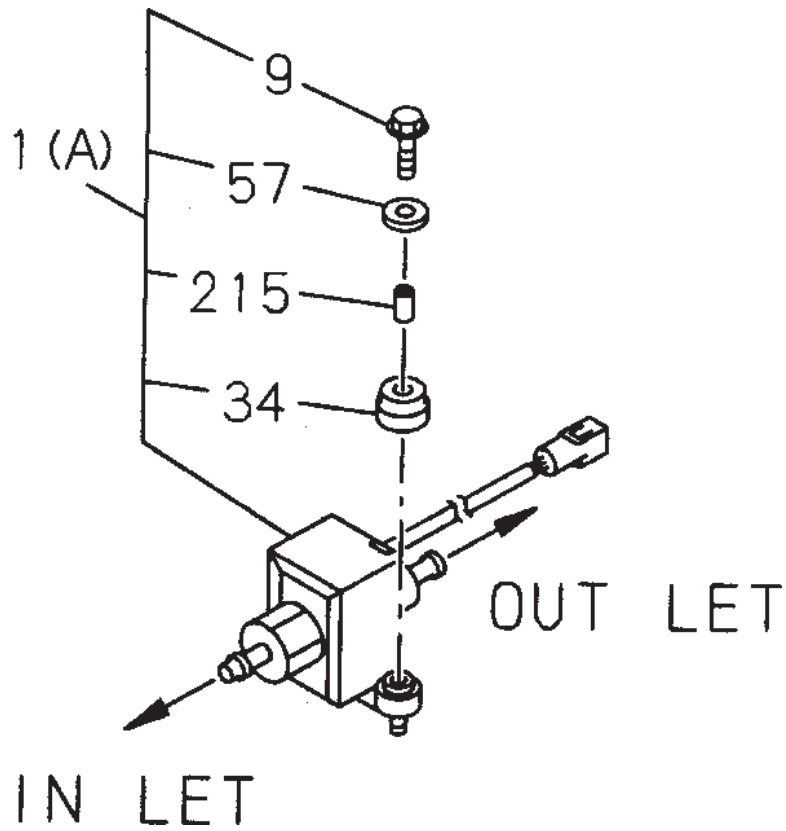

# ISUZU 3LB1 — FUEL PUMP AND PIPE ASSY.

## FUEL PUMP AND PIPE ASSY.

<u>NO.</u>	<u>PART NO.</u>	<u>PART NAME</u>	<u>QTY.</u>	<u>REMARKS</u>
1	8942411792	FUEL PUMP ASSY. ....	1 .....	INCL. ITEMS W/*
9*	9019106280	BOLT	2	
34*	8942336550	RUBBER	2	
57*	8942336570	WASHER	2	
215*	8942389070	COLLAR	2	

OIL FILTER ASSY.

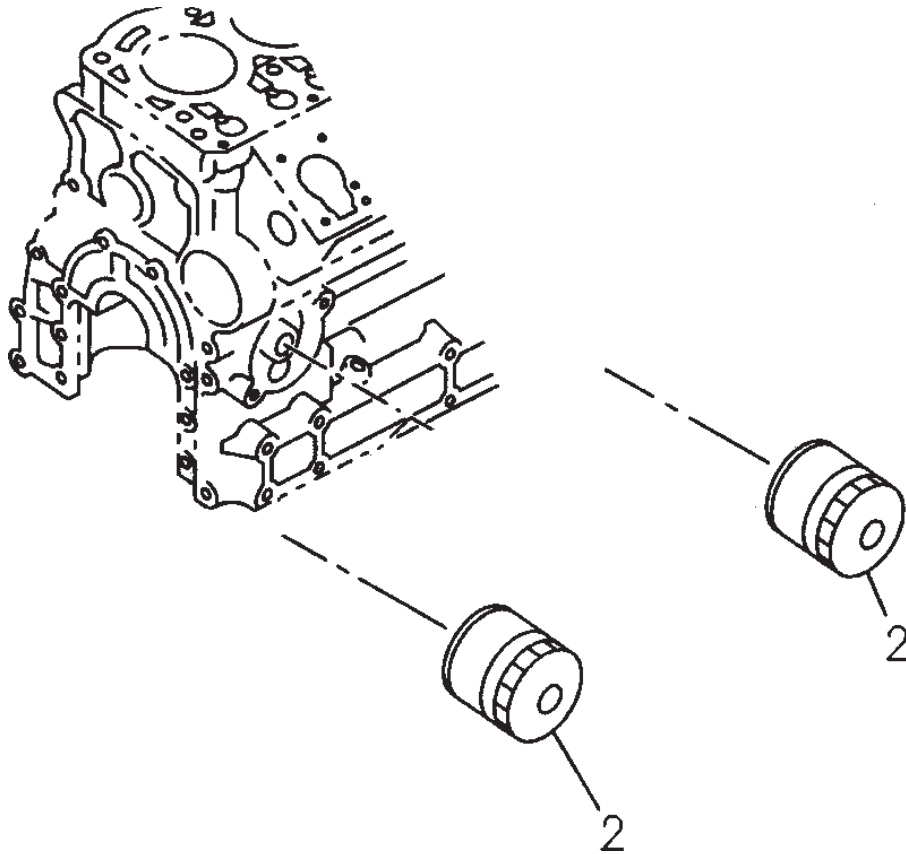

OIL FILTER ASSY.

<u>NO.</u>	<u>PART NO.</u>	<u>PART NAME</u>	<u>QTY.</u>	<u>REMARKS</u>
2	8943142633	OIL FILTER ELEMENT	1	

# ISUZU 3LB1 — OIL PUMP AND OIL STRAINER ASSY.

OIL PUMP AND OIL STRAINER ASSY.

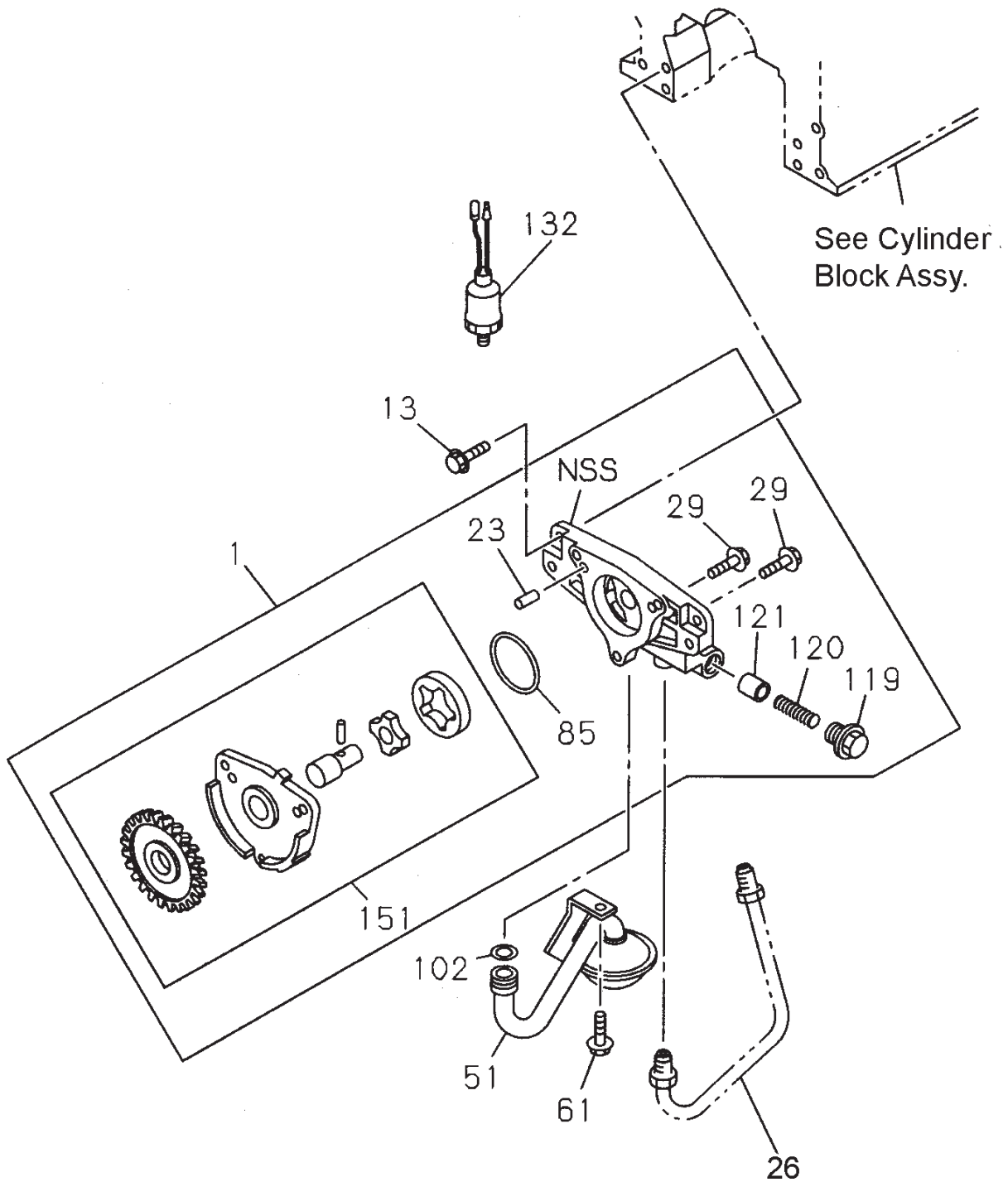

# ISUZU 3LB1 — OIL PUMP AND OIL STRAINER ASSY.

## OIL PUMP AND OIL STRAINER ASSY.

<u>NO.</u>	<u>PART NO.</u>	<u>PART NAME</u>	<u>QTY.</u>	<u>REMARKS</u>
1	8970488094	OIL PUMP ASSY. ....	1	INCL. ITEMS W/*
13	0280808300	BOLT	4	
23*	9081606160	PIN	2	
26	8970448430	OIL PUMP PIPE	1	
29*	0280806300	BOLT, M6X30 FLANGE	2	
	0280806500	BOLT, M6X50 FLANGE	1	
51	8970439410	STRAINER AND PIPE ASSY.	1	
61	0280808160	BOLT	1	
85*	8971096790	GASKET	1	
102	1096234960	GASKET STRAINER	1	
119*	8942446550	RELIEF VALVE PLUG .....	1	APR. 1992 TO NOV. 1994
	8941046150	RELIEF VALVE PLUG .....	1	DEC. 1994~
120*	8941145120	RELIEF VALVE SPRING .....	1	APR. 1992 TO NOV. 1994
	8971133320	RELIEF VALVE SPRING .....	1	DEC. 1994~
121*	8942355671	VALVE	1	
132	5824100361	OIL PRESSURE SWITCH	1	
151*	8970448133	OIL PUMP SUB ASSY.	1	

# ISUZU 3LB1 — ELECTRICAL CONTROL ASSY.

## ELECTRICAL CONTROL ASSY.

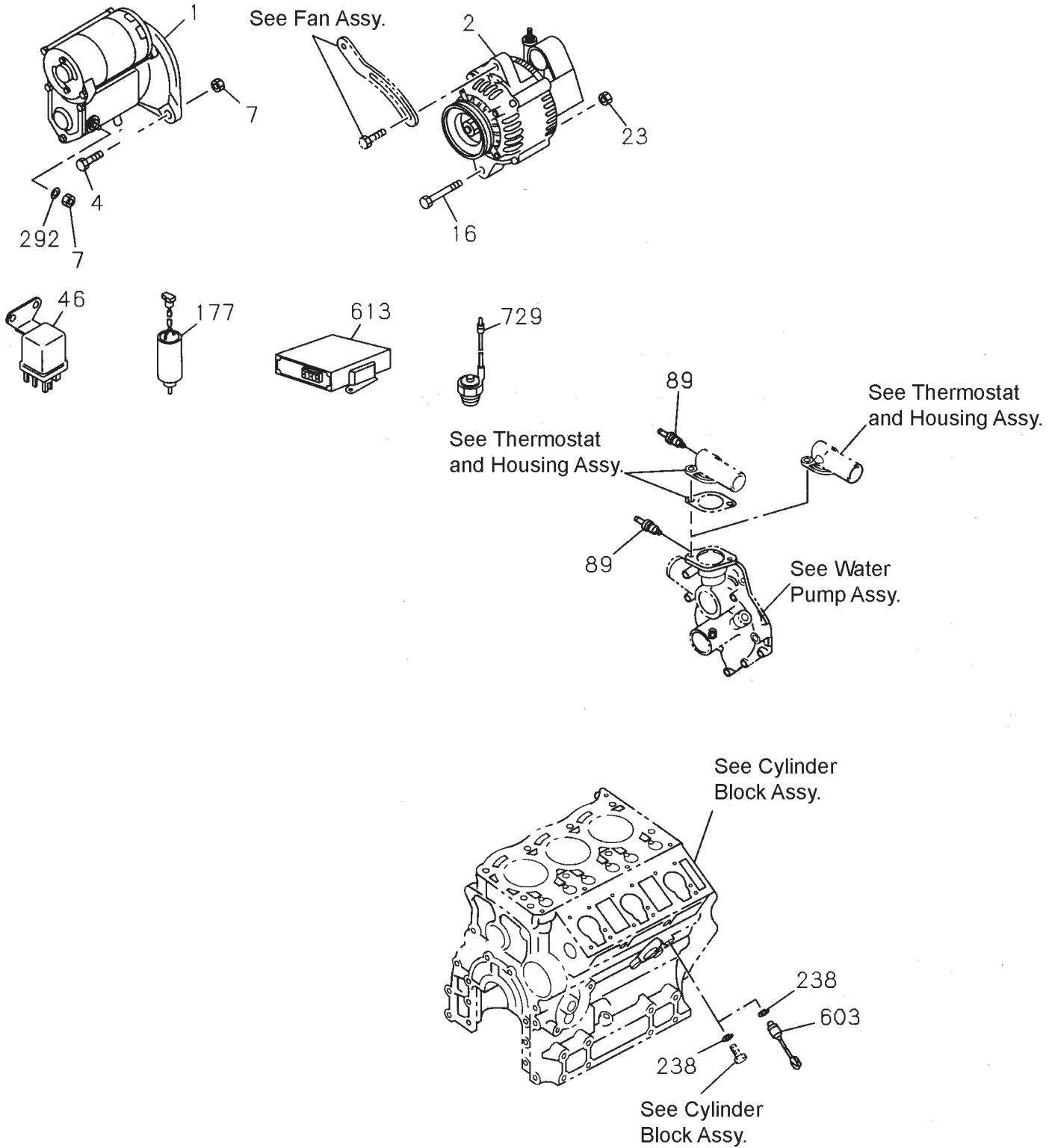



# ISUZU 3LB1 — ELECTRICAL CONTROL ASSY.

## ELECTRICAL CONTROL ASSY.

<u>NO.</u>	<u>PART NO.</u>	<u>PART NAME</u>	<u>QTY.</u>	<u>REMARKS</u>
1	8970489652	STARTER ASSY.	1	
2	8970489701	GENERATOR ASSY.	1	
4	0281812300	BOLT	2	
7	9091114080	NUT	1	
16	0280810700	BOLT	1	
23	0911502100	NUT	1	
46	8942481610	GLOW PLUG RELAY	1	
89	8941679410	SWITCH	1	
177	8970701303	SOLENOID ASSY. ....	1	APR. 1992 TO JUL. 1998
	8971830140	SOLENOID ASSY. ....	1	AUG. 1998~
238	9095720140	GASKET	1	
292	9091505080	LOCKWASHER	1	
603	8941268220	SENSOR ASSY.	1	
613	8970912901	CONTROL UNIT .....	1	APR. 1992 TO JUN. 1992
	8971163140	CONTROL UNIT .....	1	JUL. 1992 TO MAY 1996
	8971461050	CONTROL UNIT .....	1	JUN. 1996~
729	8970633010	SENSOR	1	

# ISUZU 3LB1 — STARTER COMP. ASSY.

STARTER COMP. ASSY.

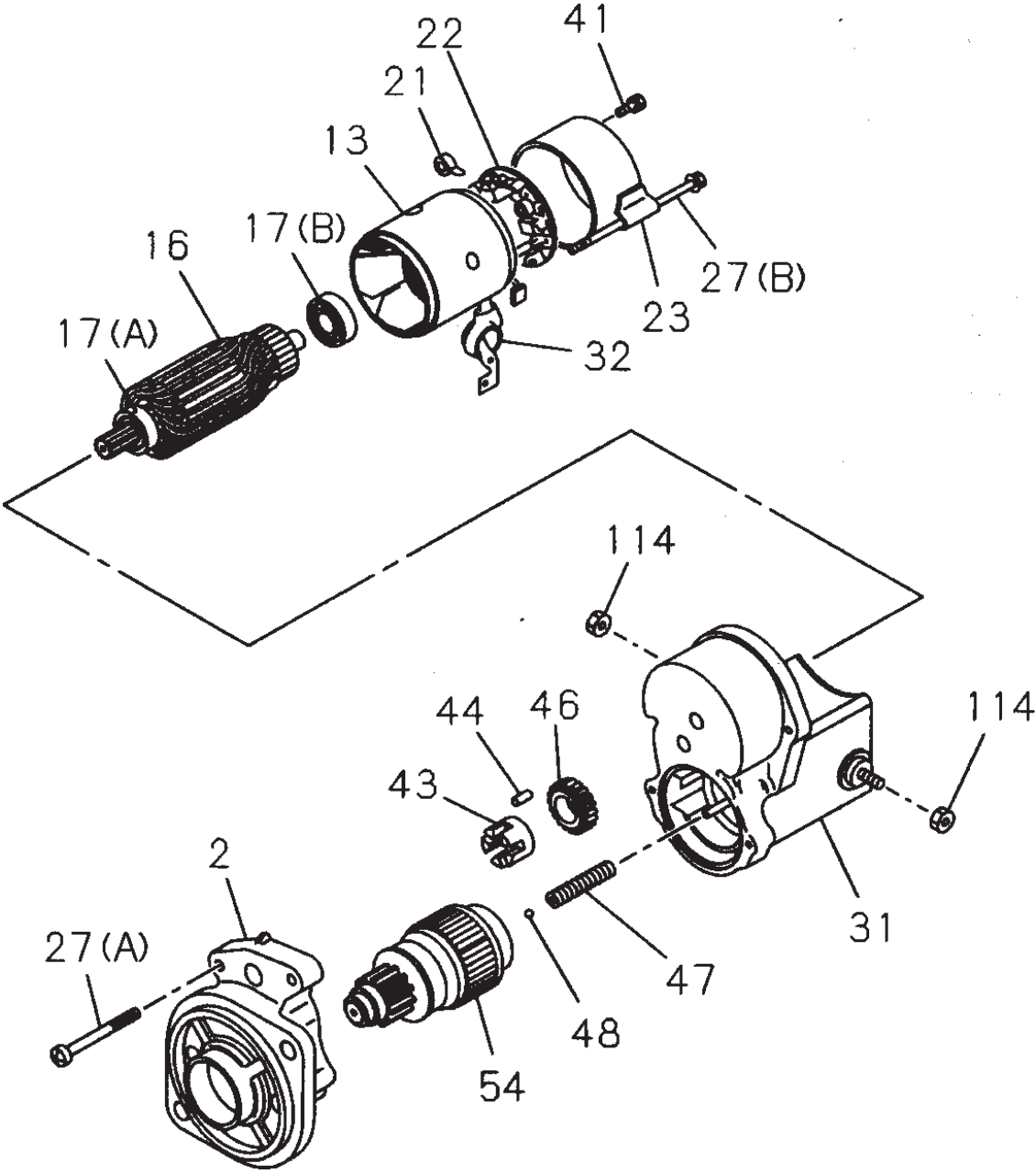

# ISUZU 3LB1 — STARTER COMP. ASSY.

## STARTER COMP. ASSY.

<u>NO.</u>	<u>PART NO.</u>	<u>PART NAME</u>	<u>QTY.</u>	<u>REMARKS</u>
2	8970786480	CASE	1	
13	581110110	YOKE	1	
16	5811210310	ARMATURE	1	
17A	5098000790	BEARING	1	
17B	5098000400	BEARING	1	
21	5811170070	SPRING	4	
22	5811180220	HOLDER	1	
23	581150340	COVER	1	
27A	5811291820	BOLT	2	
27B	5811291830	BOLT	2	
31	8970786470	SWITCH	1	
32	5811190290	COVER	1	
41	5811291810	SCREW	2	
43	5811291000	RETAINER	1	
44	5811290990	ROLLER	5	
46	5811230110	GEAR	1	
47	5811290960	SPRING	1	
48	5811290920	BALL	1	
54	5811240031	CLUTCH	1	
114	5094000420	NUT	1	

# ISUZU 3LB1 — INJ. PUMP COMP. ASSY.

INJ. PUMP COMP. ASSY.

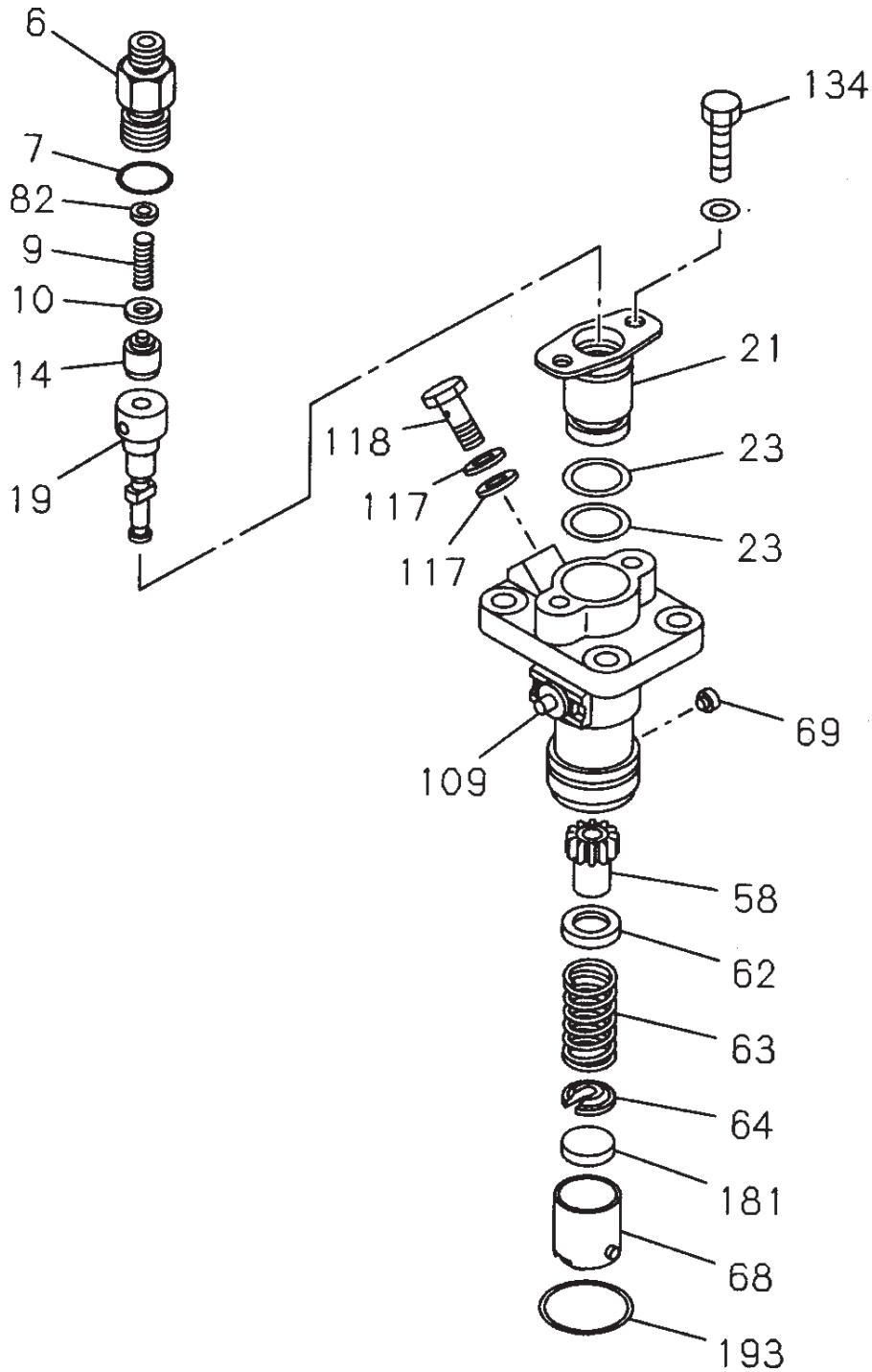

# ISUZU 3LB1 — INJ. PUMP COMP. ASSY.

## INJ. PUMP COMP. ASSY.

<u>NO.</u>	<u>PART NO.</u>	<u>PART NAME</u>	<u>QTY.</u>	<u>REMARKS</u>
6	8941327461	HOLDER	3	
7	8941289150	GASKET	3	
9	8941289110	SPRING	3	
10	8941289120	GASKET	3	
14	8970833460	VALVE	3	
19	8970833450	PLUNGER ASSY. ....	3	APR. 1992 TO FEB. 1995
	8971386490	PLUNGER ASSY. ....	3	MAR. 1995~
21	8970833480	FLANGE	3	
23	8943796920	GASKET	6	
58	8941289230	SLEEVE	3	
62	8941289200	SEAT	3	
63	8941289190	SPRING	3	
64	8941289210	SEAT	3	
68	8941289160	TAPPET	3	
69	8970833490	TAPPET GUIDE	3	
82	8970833470	HOUSING PLUG	3	
109	8970833551	RACK	3	
117	8941445880	GASKET	6	
118	8943796880	BOLT	3	
134	8943796910	BOLT	6	
181	8941289310	SHIM .....	1	T=2.60
	8941289320	SHIM .....	1	T=2.65
	8941289330	SHIM .....	1	T=2.70
	8941289340	SHIM .....	1	T=2.75
	8941289350	SHIM .....	1	T=2.80
	8941289360	SHIM .....	1	T=2.85
	8941589370	SHIM .....	1	T=2.90
	8941289380	SHIM .....	1	T=2.95
	8941289390	SHIM .....	1	T=3.00
	8941289400	SHIM .....	1	T=3.05
	8941289410	SHIM .....	1	T=3.10
	8941289420	SHIM .....	1	T=3.15
	8941289430	SHIM .....	1	T=3.20
	8941289440	SHIM .....	1	T=3.25
	8941289450	SHIM .....	1	T=3.30
	8941289460	SHIM .....	1	T=3.35
	8941289470	SHIM .....	1	T=3.40
	8941289480	SHIM .....	1	T=3.45
	8941289490	SHIM .....	1	T=3.50
	8941289500	SHIM .....	1	T=3.55
	8941289510	SHIM .....	1	T=3.60
	8941289520	SHIM .....	1	T=3.65
	8941289530	SHIM .....	1	T=3.70
	8941289540	SHIM .....	1	T=3.75

# ISUZU 3LB1 — INJ. PUMP COMP. ASSY.

INJ. PUMP COMP. ASSY.

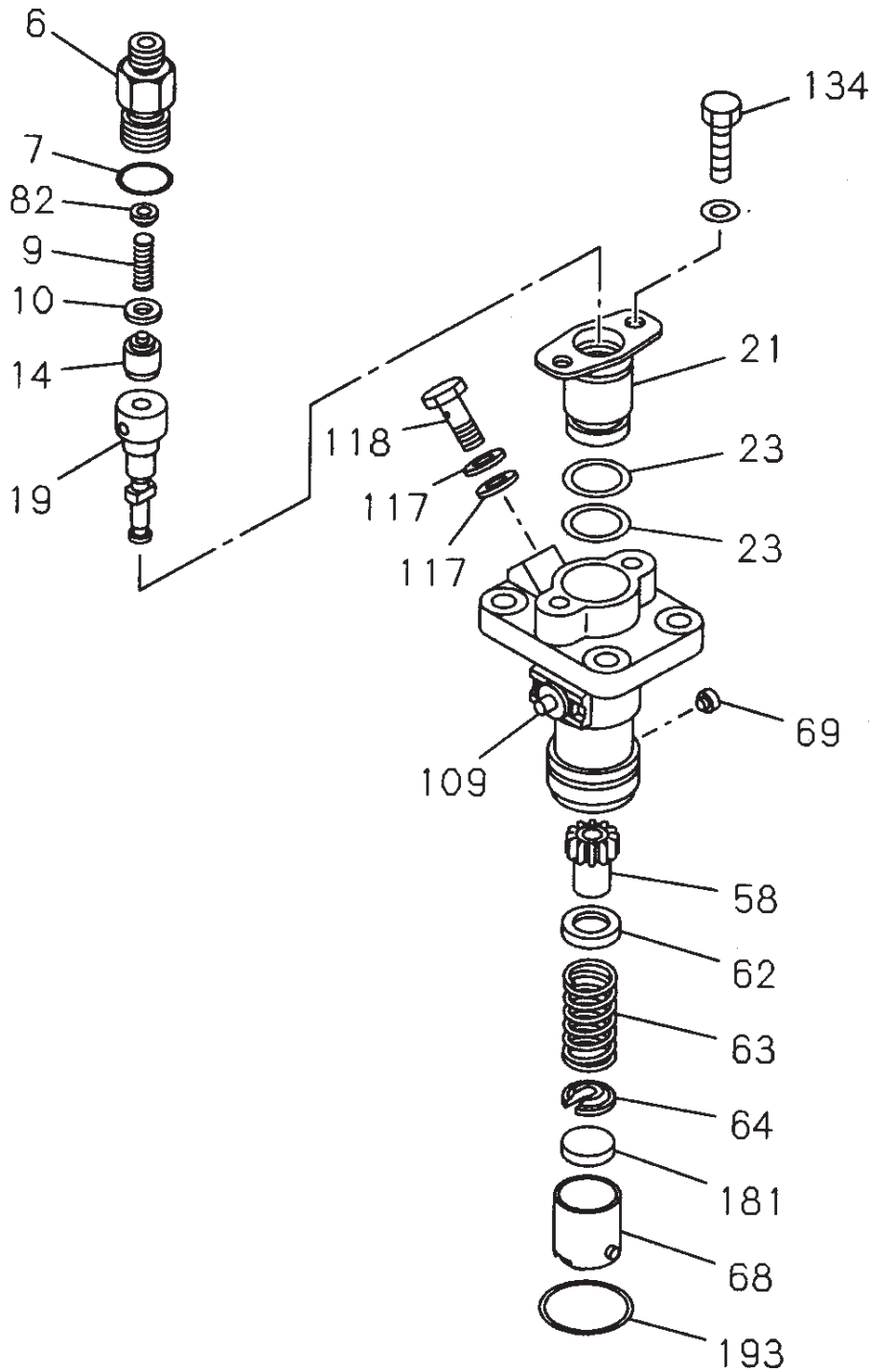

# ISUZU 3LB1 — INJ. PUMP COMP. ASSY.

NJ. PUMP COMP. ASSY.

<u>NO.</u>	<u>PART NO.</u>	<u>PART NAME</u>	<u>QTY.</u>	<u>REMARKS</u>
	8941289550	SHIM .....	1 .....	T=3.80
	8941289560	SHIM .....	1 .....	T=3.85
	8941289570	SHIM .....	1 .....	T=3.90
	8941289580	SHIM .....	1 .....	T=3.95
	8941289590	SHIM .....	1 .....	T=4.00
	8941289600	SHIM .....	1 .....	T=4.05
	8941289610	SHIM .....	1 .....	T=4.10
193	8970833500	SNAP RING	3	

# ISUZU 3LB1 — TIMING CHAIN CASE ASSY.

## TIMING CHAIN CASE ASSY.

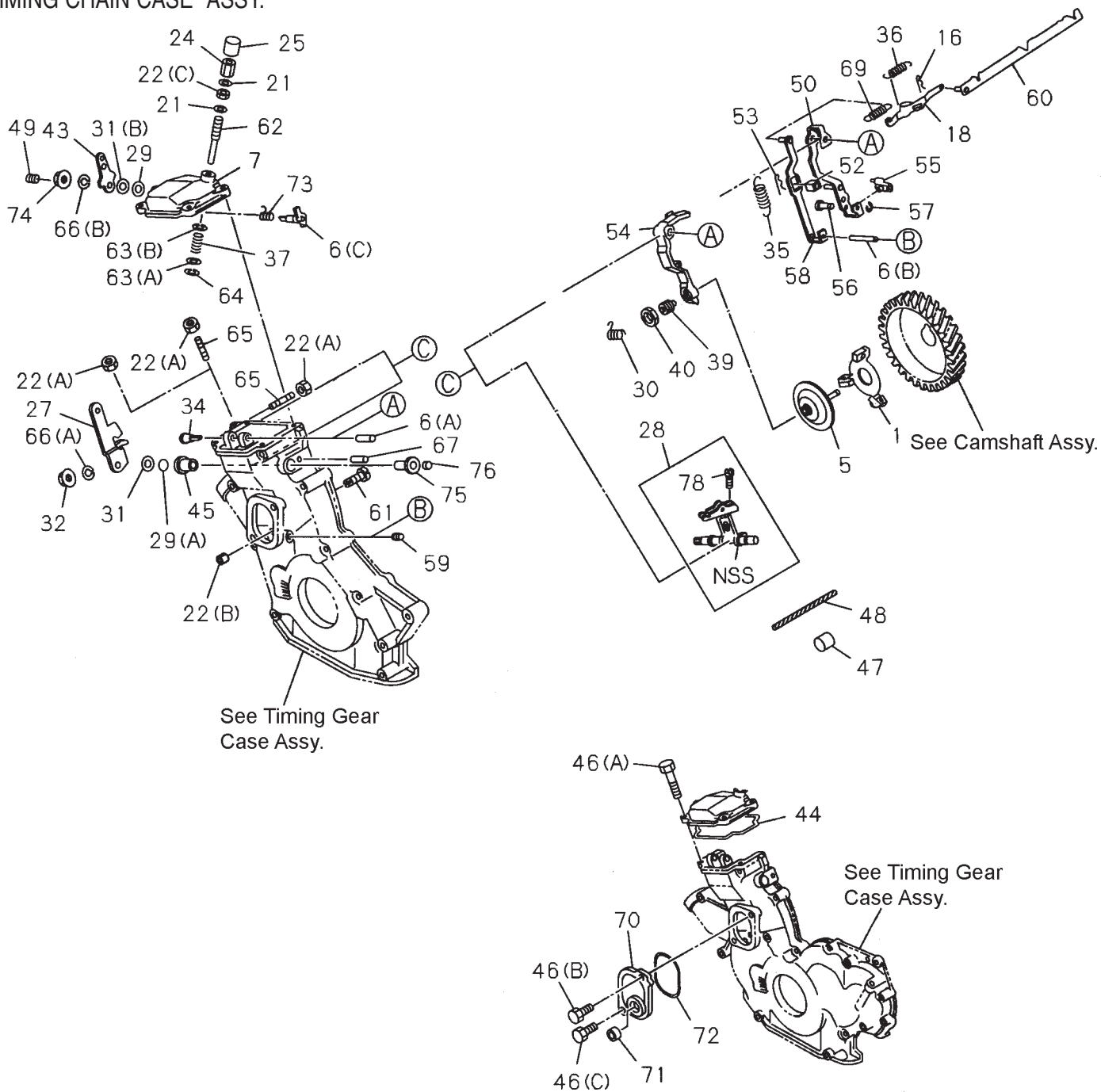



# ISUZU 3LB1 — TIMING CHAIN CASE ASSY.

## TIMING CHAIN CASE ASSY.

<u>NO.</u>	<u>PART NO.</u>	<u>PART NAME</u>	<u>QTY.</u>	<u>REMARKS</u>
1	8970456175	FLYWEIGHT	1	
5	8970849771	SLEEVE .....	1	APR. 1992 TO MAR. 1996
	8971474890	SLEEVE .....	1	APR. 1996~
6A	9081608500	LEVER SHAFT	1	
6B	9081605450	LEVER SHAFT	1	
6C	8970164460	LEVER SHAFT	1	
7	8971176720	COVER .....	1	APR. 1992 TO JUN. 1996
	8971062740	COVER .....	1	JUL. 1996 TO JAN. 1997
	8971617450	COVER .....	1	FEB. 1997~
16	1079470020	LEVER PIN	1	
18	8970346393	PLATE .....	1	APR. 1992 TO JUN. 1996
	8971485500	PLATE .....	1	JUL. 1996~
21	5095031320	GASKET SCREW	2	
22A	9091114060	NUT	3	
22B	9091104060	NUT	1	
24	5094000480	NUT	1	
25	5156690021	CAP	1	
27	8970493280	LEVER	1	
28	8971059061	LEVER .....	1	APR. 1992 TO JUN. 1996
	8971605721	LEVER .....	1	JUL. 1996~
29	1096230550	GASKET	2	
30	8970169400	SPRING	1	
31	5095031350	WASHER	2	
32	9091105080	NUT	1	
34	5157292391	EYE	1	
35	987109759	MAIN SPRING	1	
36	8970843250	START SPRING	1	
37	8970169361	IDLE SPRING	1	
39	8971097751	ANGLEICH KIT	1	
40	8941304380	NUT	1	
43	8970164492	LEVER	1	
44	8970646881	COVER GASKET	1	
45	8943695450	GEAR CASE BUSHING	1	
46A	0280806200	BOLT	4	
46B	0280806140	BOLT	1	
46C	8970728300	BOLT	1	
47	1157390020	LEAD SEAL	2	
48	8913254460	LEAD SEAL WIRE	2	
49	1096050190	COVER PLUG	1	
50	8970345945	GUIDE LEVER	1	
52	8971122650	GUIDE PIECE .....	1	REPLACES 8970718062
53	1097470020	GUIDE LEVER PIN	1	
54	8971059100	TENSION LEVER	1	

# ISUZU 3LB1 — TIMING CHAIN CASE ASSY.

## TIMING CHAIN CASE ASSY.

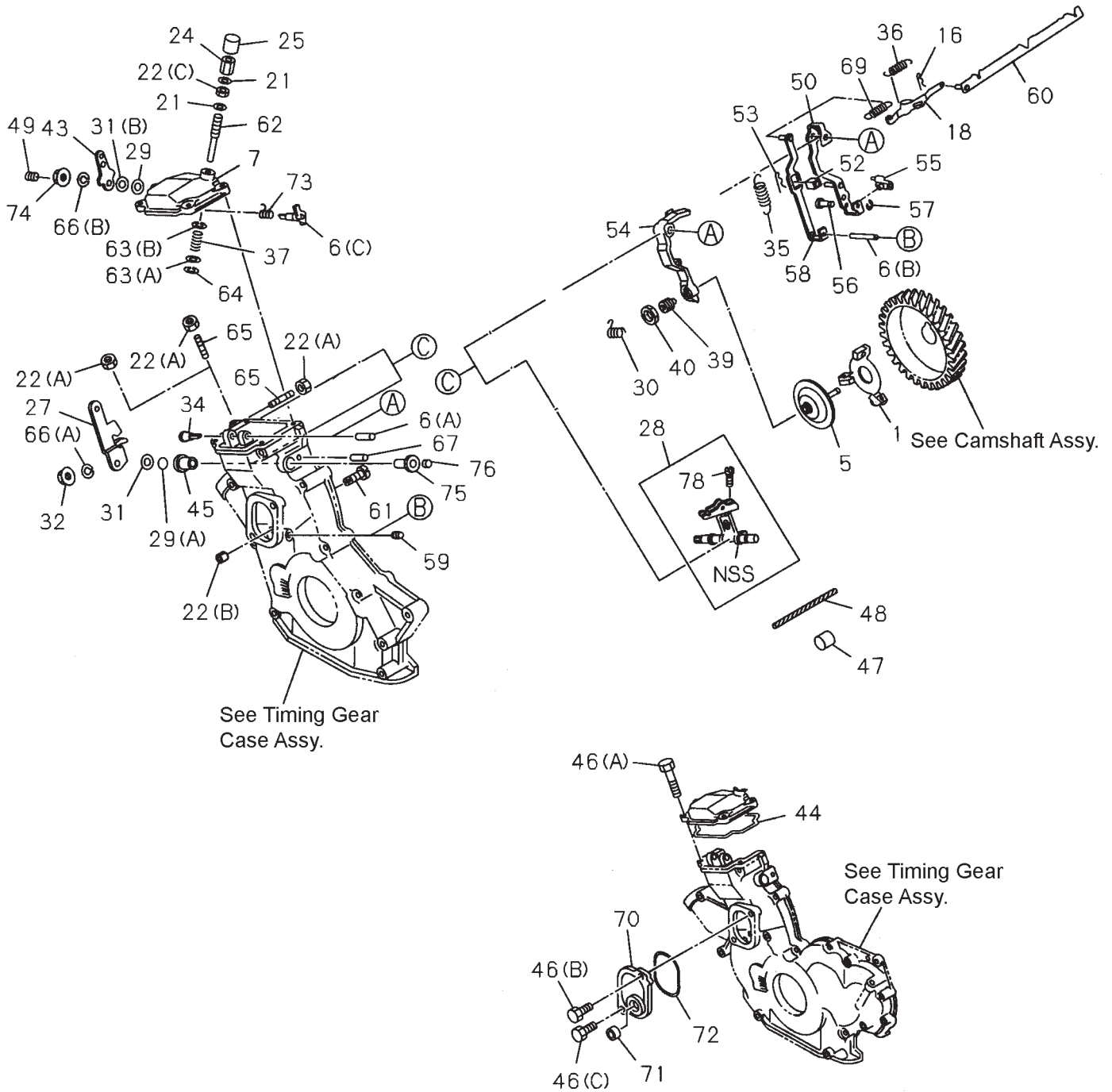

# ISUZU 3LB1 — TIMING CHAIN CASE ASSY.

## TIMING CHAIN CASE ASSY.

<u>NO.</u>	<u>PART NO.</u>	<u>PART NAME</u>	<u>QTY.</u>	<u>REMARKS</u>
55	8970346383	SHIFTER	1	
56	9082136250	SHAFT	1	
57	9091854040	SNAP RING	1	
58	8970624222	FLOATING LEVER .....	1 .....	APR. 1992 TO JUN. 1996
	8971485480	FLOATING LEVER .....	1 .....	JUL. 1996~
59	1096050500	PLUG	1	
60	8971062050	LINK .....	1 .....	DEC. 1993 TO APR. 1995
	8971062051	LINK .....	1 .....	MAY 1995~
61	8970395841	SCREW	1	
62	8970164410	SCREW	1	
63A	9091605040	IDLE WASHER	1	
63B	9091607040	IDLE WASHER	1	
64	9091854030	SNAP RING	1	
65	8943176381	SCREW	2	
66	9091505080	LOCK WASHER	1	
67	9081604360	PIN	1	
69	8970837140	SET SPRING	1	
70	8970392644	COVER	1	
71	5111290060	SEALING CUP	1	
72	9095612530	COVER GASKET	1	
73	8970395461	SPRING	1	
74	9091105080	NUT	1	
75	8970388021	BUSHING	1	
76	8944546150	CUP	1	
78	8971059090	ADJUSTER	1	

# ISUZU 3LB1 —AIR CLEANER ASSY.

AIR CLEANER ASSY.

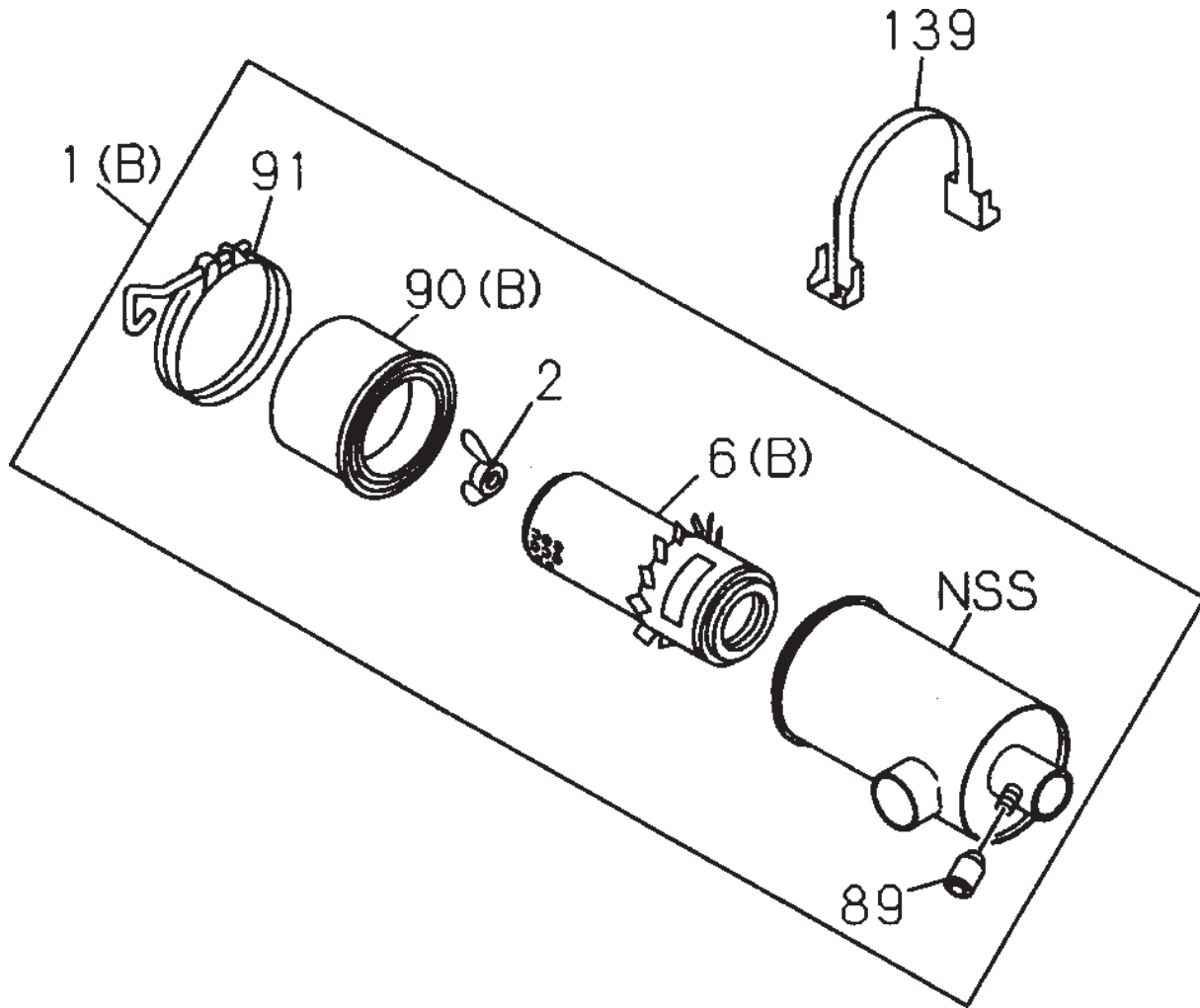

# ISUZU 3LB1 — AIR CLEANER ASSY.

## AIR CLEANER ASSY.

<u>NO.</u>	<u>PART NO.</u>	<u>PART NAME</u>	<u>QTY.</u>	<u>REMARKS</u>
1	8941251130	CLEANER ASSY. ....	1 .....	INCL. ITEMS W/*
2*	9142170620	WING NUT	1	
6*	5142150140	AIR CLEANER FILTER	1	
89*	9142191410	INDICATOR	1	
90*	8941591510	CUP	1	
91*	5142170040	CLAMP	1	
139	8970497220	AIR CLEANER BAND	2	

# ISUZU 3LB1 — SWITCH AND RELAY ASSY.

SWITCH AND RELAY ASSY.

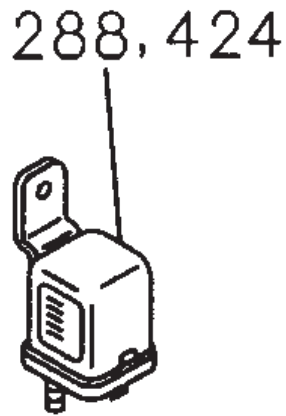
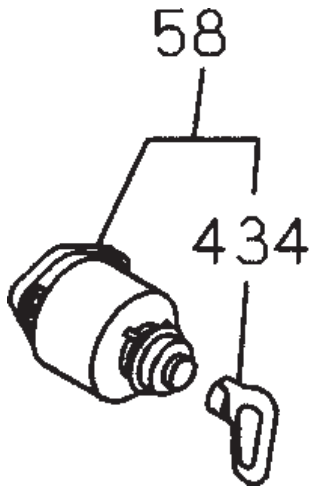

# ISUZU 3LB1 — SWITCH AND RELAY ASSY.

## SWITCH AND RELAY ASSY.

<u>NO.</u>	<u>PART NO.</u>	<u>PART NAME</u>	<u>QTY.</u>	<u>REMARKS</u>
58	8970444180	IGNITION SWITCH .....	1 .....	INCL. ITEMS W/*
288	5825500290	SAFETY RELAY	1	
424	5825500290	RELAY	2	
434*	1823160070	STARTER SWITCH KEY	1	

**PAYMENT TERMS**

Terms of payment for parts are net 10 days.

**FREIGHT POLICY**

All parts orders will be shipped collect or prepaid with the charges added to the invoice. All shipments are F.O.B. point of origin. Multiquip's responsibility ceases when a signed manifest has been obtained from the carrier, and any claim for shortage or damage must be settled between the consignee and the carrier.

**MINIMUM ORDER**

The minimum charge for orders from Multiquip is \$15.00 net. Customers will be asked for instructions regarding handling of orders not meeting this requirement.

**RETURNED GOODS POLICY**

Return shipments will be accepted and credit will be allowed, subject to the following provisions:

1. A Returned Material Authorization must be approved by Multiquip prior to shipment.
2. To obtain a Return Material Authorization, a list must be provided to Multiquip Parts Sales that defines item numbers, quantities, and descriptions of the items to be returned.
  - a. The parts numbers and descriptions must match the current parts price list.
  - b. The list must be typed or computer generated.
  - c. The list must state the reason(s) for the return.
  - d. The list must reference the sales order(s) or invoice(s) under which the items were originally purchased.
  - e. The list must include the name and phone number of the person requesting the RMA.
3. A copy of the Return Material Authorization must accompany the return shipment.

4. Freight is at the sender's expense. All parts must be returned freight prepaid to Multiquip's designated receiving point.
5. Parts must be in new and resalable condition, in the original Multiquip package (if any), and with Multiquip part numbers clearly marked.
6. The following items are not returnable:
  - a. Obsolete parts. (If an item is listed in the parts price book as being replaced by another item, it is obsolete.)
  - b. Any parts with a limited shelf life (such as gaskets, seals, "O" rings, and other rubber parts) that were purchased more than six months prior to the return date.
  - c. Any line item with an extended dealer net price of less than \$5.00.
  - d. Special order items.
  - e. Electrical components.
  - f. Paint, chemicals, and lubricants.
  - g. Decals and paper products.
  - h. Items purchased in kits.
7. The sender will be notified of any material received that is not acceptable.
8. Such material will be held for 5 working days from notification, pending instructions. If a reply is not received within 5 days, the material will be returned to the sender at his expense.
9. Credit on returned parts will be issued at dealer net price at time of the original purchase, less a 15% restocking charge.
10. In cases where an item is accepted for which the original purchase document can not be determined, the price will be based on the list price that was effective twelve months prior to the RMA date.
11. Credit issued will be applied to future purchases only.

**PRICING AND REBATES**

Prices are subject to change without prior notice. Price changes are effective on a specific date and all orders received on or after that date will be billed at the revised price. Rebates for price declines and added charges for price increases will not be made for stock on hand at the time of any price change.

Multiquip reserves the right to quote and sell direct to Government agencies, and to Original Equipment Manufacturer accounts who use our products as integral parts of their own products.

**SPECIAL EXPEDITING SERVICE**

A \$20.00 to \$50.00 surcharge will be added to the invoice for special handling including bus shipments, insured parcel post or in cases where Multiquip must personally deliver the parts to the carrier.

**LIMITATIONS OF SELLER'S LIABILITY**

Multiquip shall not be liable here under for damages in excess of the purchase price of the item with respect to which damages are claimed, and in no event shall Multiquip be liable for loss of profit or good will or for any other special, consequential or incidental damages.

**LIMITATION OF WARRANTIES**

No warranties, express or implied, are made in connection with the sale of parts or trade accessories nor as to any engine not manufactured by Multiquip. Such warranties made in connection with the sale of new, complete units are made exclusively by a statement of warranty packaged with such units, and Multiquip neither assumes nor authorizes any person to assume for it any other obligation or liability whatever in connection with the sale of its products. A part from such written statement of warranty, there are no warranties, express, implied or statutory, which extend beyond the description of the products on the face hereof.





# PARTS AND OPERATION MANUAL

## **HERE'S HOW TO GET HELP**

*PLEASE HAVE THE MODEL AND SERIAL NUMBER  
ON-HAND WHEN CALLING*

### **PARTS DEPARTMENT**

*800/427-1244 or 310/537-3700*

*FAX: 800/672-7877 or 310/637-3284*

### **SERVICE DEPARTMENT**

*800/835-2551 or 310/537-3700*

*FAX: 310/638-8046*

### **WARRANTY DEPARTMENT**

*800/835-2551 or 310/537-3700*

*FAX: 310/638-8046*

### **MAIN**

*800/421-1244 or 310/537-3700*

*FAX: 310/537-3927*

© COPYRIGHT 2001, MULTIQIP INC.



#### **MULTIQIP INC.**

18910 WILMINGTON AVE.  
CARSON, CALIFORNIA 90746  
310-537-3700  
800-421-1244  
FAX: 310-537-3927

**E-mail: [mq@multiquip.com](mailto:mq@multiquip.com) • [www.multiquip.com](http://www.multiquip.com)**

#### **PARTS DEPARTMENT:**

800-427-1244  
FAX: 800-672-7877

#### **SERVICE DEPARTMENT:**

800-835-2551  
FAX: 310-638-8046

## Free Manuals Download Website

<http://myh66.com>

<http://usermanuals.us>

<http://www.somanuals.com>

<http://www.4manuals.cc>

<http://www.manual-lib.com>

<http://www.404manual.com>

<http://www.luxmanual.com>

<http://aubethermostatmanual.com>

Golf course search by state

<http://golfingnear.com>

Email search by domain

<http://emailbydomain.com>

Auto manuals search

<http://auto.somanuals.com>

TV manuals search

<http://tv.somanuals.com>