

PARTS AND OPERATION MANUAL

MQ POWER DCA-60SSAI WHISPERWATT™ GENERATOR (Standard)

© COPYRIGHT 2001, MULTIQUIP INC.

PARTS LIST NO. 7451201B

FINAL COPY



MULTIQUIP INC.

18910 WILMINGTON AVE.
CARSON, CALIFORNIA 90746
310-537-3700
800-421-1244
FAX: 310-537-3927

PARTS DEPARTMENT:

800-427-1244
FAX: 800-672-7877

SERVICE DEPARTMENT:

800-835-2551
FAX: 310-638-8046

E-mail: mq@multiquip.com • www.multiquip.com



WARNING



CALIFORNIA--Proposition 65 Warning

Engine exhaust and some of its constituents are known to the State of California to cause cancer, birth defects and other reproductive harm.

HERE'S HOW TO GET HELP

*PLEASE HAVE THE MODEL AND SERIAL NUMBER
ON-HAND WHEN CALLING*

PARTS DEPARTMENT

800/427-1244 or 310/537-3700

FAX: 800/672-7877 or 310/637-3284

SERVICE DEPARTMENT

800/835-2551 or 310/537-3700

FAX: 310/638-8046

WARRANTY DEPARTMENT

800/835-2551 or 310/537-3700

FAX: 310/638-8046

MAIN

800/421-1244 or 310/537-3700

FAX: 310/537-3927

TABLE OF CONTENTS

Here's How To Get Help	3
Table Of Contents	4
Parts Ordering Procedures	5
Rules for Safe Operation	6-9
Towing and Transportation	10
Trailer Safety Guidelines	11-17
Trailer Wiring Diagram	18
Electric Brake Troubleshooting	19
Hydraulic Brake Troubleshooting	20
Operation Decals	21-22
DCA -60SS12 Specifications	23
General Information	24
Major Components	55
Dimensions	26
Control Panel Descriptions	28-29
Engine Operating Panel Descriptions	30-31
Output Terminal Panel Descriptions	32-33
Output Amperage Setup	34-35
Output Voltage Setup	36-39
Installation	40-41
Pre Set-up	42-45
Load Application	46
Generator Start-up Procedure	47-49
Generator Shut-down Procedure	50
Maintenance	52-55
Generator Wiring Diagram	56
Engine Wiring Diagram	57
Engine Troubleshooting	58-59
Generator/Engine Troubleshooting	60
Explanation of Codes in Remarks Column	62
Suggested Spare Parts	63

MQ POWER DCA-60SSAI AC GENERATOR

Generator Assembly	64-65
Control Box Assembly	66-67
Engine & Radiator Assembly	68-71
Engine Operating Panel Assembly	72-75
Battery Assembly	76-77
Muffler Assembly	78-79
Fuel Tank Assembly	80-81
Enclosure Assembly	82-85
Rubber Seal Assembly	86-87
Name Plate And Decals	88-89

ISUZU 6BD1 ENGINE

Cylinder Head Cover Assembly	90-91
Cylinder Head Assembly	92-93
Cylinder Block Assembly	94-97
Oil Pan and Level Gauge Assembly	98-99
Camshaft and Valve Assembly	100-101
Crankshaft Piston and Flywheel Assembly	102-103
Timing Gear and Flywheel Housing Assembly	104-105
Inlet Manifold Assembly	106-107
Exhaust Manifold Assembly	108-109
Ventilation Assembly	110-111
Water Pump and Corrosion Resistor Assembly	112-113
Thermostat and Housing Assembly	114-115
Engine Water Piping Assembly	116-117
Fan and Fan Belt Assembly	118-119
Fuel Injection Assembly	120-121
Fuel Filter and Bracket Assembly	122-123
Fuel Pump and Pipe Assembly	124-125
Oil Cooler and Oil Filter Assembly	126-127
Oil Pump and Oil Strainer Assembly	128-129
Oil and Vacuum Piping Assembly	130-131
Electrical Control Assembly	132-133
Starter Components Assembly	134-135
Alternator Components Assembly	136-137
Injection Pump Components Assembly	138-141
Governor Components Assembly	142-145
Feed Pump Assembly	146-147
Misc. Injection Pump Assembly	148-149
Coupling Assembly	150-151
Water Sedimenter Assembly	152-153
Switch and Relay Assembly	154-155

Terms and Condition of Sale — Parts	156
---	-----

NOTE

***Specification and part number
are subject to change without
notice.***

- Dealer account number
- Dealer name and address
- Shipping address (if different than billing address)
- Return fax number
- Applicable model number
- Quantity, part number and description of each part
- Specify preferred method of shipment:
 - UPS Ground
 - UPS Second Day or Third Day*
 - UPS Next Day*
 - Federal Express Priority One (please provide us with your Federal Express account number)*
 - Airborne Express*
 - Truck or parcel post

**Normally shipped the same day the order is received, if prior to 2PM west coast time.*

Earn Extra Discounts when you order by FAX!

All parts orders which include complete part numbers and are received by fax qualify for the following extra discounts:

<u>Number of line items ordered</u>	<u>Additional Discount</u>
1-9 items	3%
10+ items**	5%

Get special freight allowances when you order 10 or more line items via FAX! **

- UPS Ground Service at no charge for freight
- PS Third Day Service at one-half of actual freight cost

No other allowances on freight shipped by any other carrier.

**Common nuts, bolts and washers (all items under \$1.00 list price) do not count towards the 10+ line items.

DISCOUNTS ARE SUBJECT TO CHANGE

Fax order discount and UPS special programs revised June 1, 1995

**Extra Fax Discount
for Domestic USA
Dealers Only**

**Up to 5%
extra savings!**

**UPS
Special**
For faxed orders only

**Now! Direct TOLL-FREE access
to our Parts Department!**

Toll-free nationwide:

800-421-1244

Toll-free FAX:

800/6-PARTS-7 • 800-672-7877

RULES FOR SAFE OPERATION

CAUTION:



Failure to follow instructions in this manual may lead to serious injury or even death! This equipment is to be operated by trained and qualified personnel only! This equipment is for industrial use only.

The following safety guidelines should always be used when operating the DCA-60SSAI portable generator:

GENERAL SAFETY

- **DO NOT** operate or service this equipment before reading this entire manual.



- This equipment should not be operated by persons under 18 years of age.



- **NEVER** operate this equipment without proper protective clothing, shatterproof glasses, steel-toed boots and other protective devices required by the job.

- **NEVER** operate this equipment when not feeling well due to fatigue, illness or taking medicine.



- **NEVER** operate this equipment under the influence of drugs or alcohol.



- **NEVER** use accessories or attachments, which are not recommended by MQ Power for this equipment. Damage to the equipment and/or injury to user may result.

- Manufacturer does not assume responsibility for any accident due to equipment modifications.

- Whenever necessary, replace nameplate, operation and safety decals when they become difficult read.

- Always check the machine for loosened threads or bolts before starting.

- **NEVER** touch the hot exhaust manifold, muffler or cylinder. Allow these parts to cool before servicing engine or generator.



- **High Temperatures** – Allow the engine to cool before adding fuel or performing service and maintenance functions. Contact with *hot* components can cause serious burns.

- The engine of this generator requires an adequate free flow of cooling air. Never operate the generator in any enclosed or narrow area where free flow of the air is restricted. If the air flow is restricted it will cause serious damage to the generator or engine and may cause injury to people. The generator engine gives off **DEADLY** carbon monoxide gas.

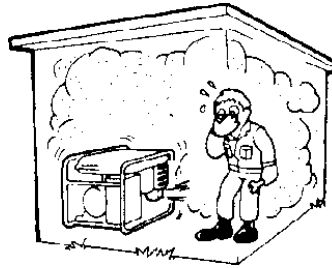

CAUTION:



- Always refuel in a well-ventilated area, away from sparks and open flames.

- Always use extreme caution when working with **flammable** liquids. When refueling, **stop the engine** and allow it to cool. **DO NOT** smoke around or near the machine. Fire or explosion could result from fuel vapors, or if fuel is spilled on a hot engine.

- **NEVER** operate the generator in an explosive atmosphere or near combustible materials. An explosion or fire could result causing severe *bodily harm or even death*.

- Topping-off to filler port is dangerous, as it tends to spill fuel.



RULES FOR SAFE OPERATION

CAUTION:

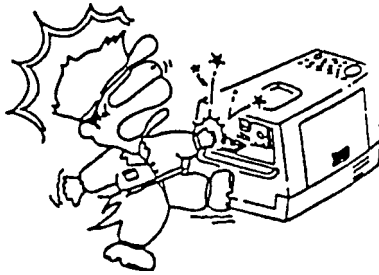

■ **NEVER** touch output terminals during operation. This is extremely dangerous. Always stop the machine when contact with the output terminals is required.

CAUTION:

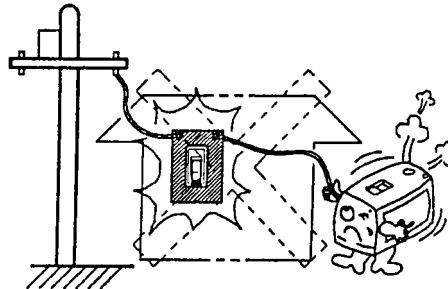
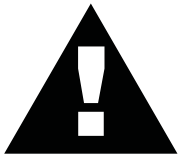

■ **Backfeed** to a utility system can cause electrocution and/or property damage. Do not connect to any building's electrical system except through an approved device or after building main switch is opened.

CAUTION:



■ **Never** use damaged or worn cables when connecting power tools or equipment to the generator. Make sure power connecting cables are securely connected to the generator's output terminals, insufficient tightening of the terminal connections may cause damage to the generator and electrical shock.

CAUTION:



DO NOT touch or open any of the below mentioned components while the generator is running. Always allow sufficient time for the engine and generator to cool before performing maintenance.

Radiator

1. **Radiator Cap** - Removing the radiator cap while the engine is hot will result in high pressurized, boiling water to gush out of the radiator, causing severe scalding to any persons in the general area of the generator.

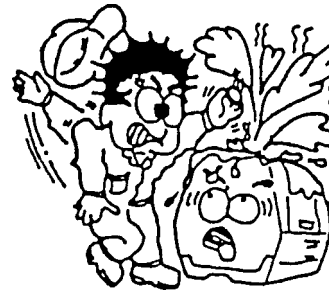

2. **Coolant Drain Plug** - Removing the coolant drain plug while the engine is hot will result in hot coolant to gush out of the coolant drain plug, therefore causing severe scalding to any persons in the general area of the generator.
3. **Engine Oil Drain Plug** - Removing the engine oil drain plug while the engine is hot will result in hot oil to gush out of the oil drain plug, therefore causing severe scalding to any persons in the general area of the generator.

Battery

CAUTION:



Never over fill the battery with water above the upper limit.

The battery contains acids that can cause injury to the eyes and skin. To avoid eye irritation, always wear safety glasses. Use well insulated gloves when picking up the battery. Use the following guidelines when handling the battery:

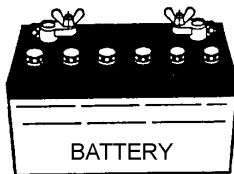

1. **DO NOT** drop the battery. There is the possibility of risk that the battery may explode.
 2. **DO NOT** expose the battery to open flames, sparks, cigarettes etc. The battery contains combustible gases and liquids. If these gases and liquids come in contact with a flame or spark, an explosion could occur.
 3. Always keep the battery charged. If the battery is not charged a buildup of combustible gas will occur.
 4. Always keep battery charging and booster cables in good working condition. Repair or replace all worn cables.
 5. Always recharge the battery in an open air environment, to avoid risk of a dangerous concentration of combustible gases.
 6. In case the battery liquid (dilute sulfuric acid) comes in contact with **clothing or skin**, rinse skin or clothing immediately with plenty of water.
 7. In case the battery liquid (dilute sulfuric acid) comes in contact with your **eyes**, rinse eyes immediately with plenty of water, then contact the nearest doctor or hospital, and seek medical attention.
- **NEVER** Run engine without air filter. Severe engine damage may occur.
 - Always service air cleaner frequently to prevent carburetor malfunction.
 - Always disconnect the battery before performing service on the generator.
 - Always be sure the operator is familiar with proper safety precautions and operations techniques before using generator.
 - Always store equipment properly when not in use. Equipment should be stored in a clean, dry location out of the reach of children.
 - **DO NOT** leave the generator running in the manual mode unattended.
 - **DO NOT** allow unauthorized people to operate this equipment.
 - Always read, understand, and follow procedures in Operator's Manual before attempting to operate equipment.
 - Refer to the **Isuzu Engine Owner's Manual** for engine technical questions or information.

Loading and Unloading (Crane)

- Before lifting, make sure the generator's lifting hook is secure and that there is no apparent damage to the generator itself (loose screws, nuts and bolts). If any part is loose or damaged, please take corrective action before lifting.
- Always drain fuel prior to lifting.
- Always make sure crane or lifting device has been properly secured to the hook of guard frame on generator.
- **NEVER** lift the machine while the engine is running.
- Use adequate lifting cable (wire or rope) of sufficient strength.
- When lifting the generator, always use the balanced center-point suspension hook and lift straight upwards.
- **NEVER** allow any person or animal to stand underneath the machine while lifting.
- When loading the generator on a truck, be sure to use the front and back frame bars as a means to secure the generator during transport.

Transporting

- Always shutdown engine before transporting.
- Tighten fuel tank cap securely.
- Drain fuel when transporting generator over long distances or bad roads.
- Always tie-down the generator during transportation by securing the generator.
- If generator is mounted on a trailer, make sure trailer complies with all local and state safety transportation laws. See page 10 for basic towing procedures.

Emergencies

- Always know the location of the nearest **fire extinguisher** and **first aid kit**. Know the location of the nearest telephone. Also know the phone numbers of the nearest **ambulance**, **doctor** and **fire department**.

Maintenance Safety

- **NEVER** lubricate components or attempt service on a running machine.
- Always allow the machine a proper amount of time to cool before servicing.
- Keep the machinery in proper running condition.
- Fix damage to the machine immediately and always replace broken parts.
- Dispose of hazardous waste properly. Examples of potentially hazardous waste are used motor oil, coolant, fuel, and fuel filters.
- **DO NOT** use plastic containers to dispose of hazardous waste.
- **DO NOT** pour waste, oil, coolant or fuel directly onto the ground, down a drain or into any water source.

DCA-60SSAI — TOWING RULES FOR SAFE OPERATION

Towing Safety Precautions

CAUTION :



Check with your county or state safety towing regulations department before towing your generator.

To reduce the possibility of an accident while transporting the generator on public roads, always make sure the trailer (Figure 1) that supports the generator and the towing vehicle are in good operating condition and both units are mechanically sound.

The following list of suggestions should be used when towing your generator:

- Make sure the hitch and coupling of the towing vehicle are rated equal to, or greater than the trailer "gross vehicle weight rating" (GVWR).
- **ALWAYS** inspect the hitch and coupling for wear. **NEVER** tow a trailer with defective hitches, couplings, chains etc.
- Check the tire air pressure on both towing vehicle and trailer. Also check the tire tread wear on both vehicles.
- **ALWAYS** make sure the trailer is equipped with a "Safety Chain".
- **ALWAYS** attach trailer's safety chain to bumper of towing vehicle.
- **ALWAYS** make sure the vehicle and trailer directional, backup, brake, and trailer lights are connected and working properly.
- The maximum speed for highway towing is **45 MPH** unless posted otherwise. Recommended off-road towing is not to exceed **10 MPH** or less depending on type of terrain.
- Place *chocked blocks* underneath wheel to prevent **rolling**, while parked.
- Place *support blocks* underneath the trailer's bumper to prevent **tipping**, while parked.
- Use the trailer's hand winch to adjust the height of the trailer, then insert locking pin to lock wheel stand in place, while parked.
- Avoid sudden stops and starts. This can cause skidding, or jack-knifing. Smooth, gradual starts and stops will improve gas mileage.
- Avoid sharp turns to prevent rolling.
- Remove wheel stand when transporting.
- **DO NOT** transport generator with fuel in tank.

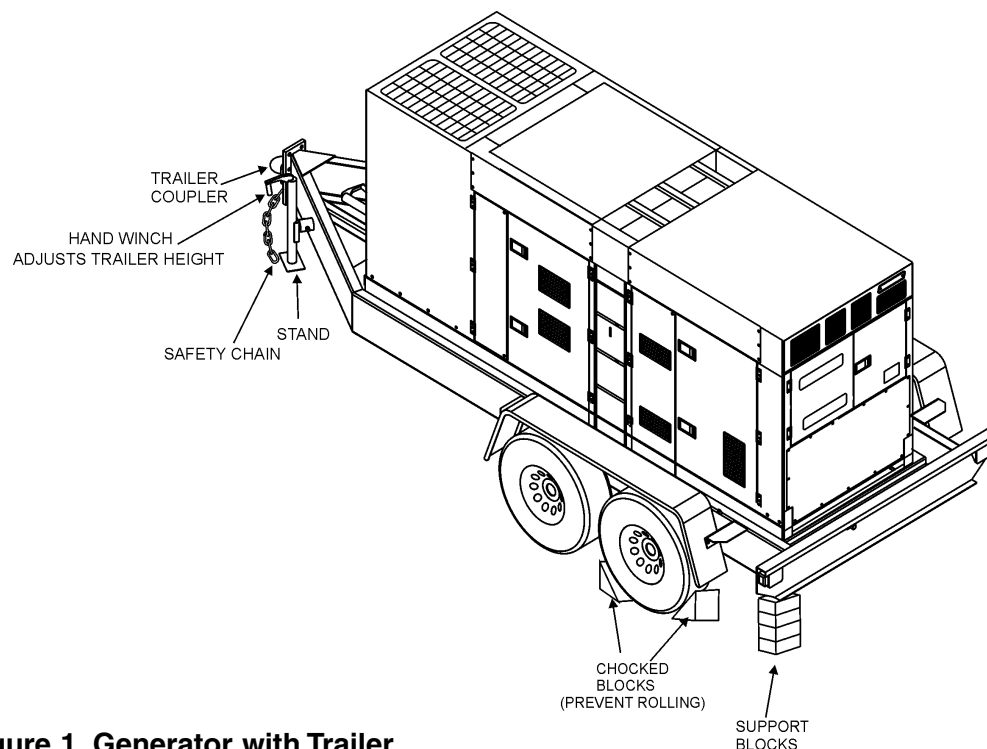

Figure 1. Generator with Trailer

CAUTION:



ALWAYS make sure the trailer is in good operating condition. Check the tires for proper inflation and wear. Also check the wheel lug nuts for proper tightness.

Explanation of Chart:

This section is to provide the user with trailer service and maintenance information. The service and maintenance guidelines referenced in this section apply a wide range of trailers. Remember periodic inspection of the trailer will ensure safe towing of the equipment and will prevent damage to the equipment and personal injury.

It is the purpose of this section to cover the major maintenance components of the trailer. The following trailer components will be discussed in this section:

- Brakes
- Tires
- Lug Nut Torquing
- Suspension
- Electrical
- Brake Troubleshooting Tables

Use the following definitions with reading Table 1.

1. **Fuel Cell** - Provides an adequate amount of fuel for the equipment in use. Fuel cells must be empty when transporting equipment.
2. **Braking System** - System employed in stopping the trailer. Typical braking systems are electric, surge, hydraulic, hydraulic-surge and air.
3. **GVWR**- Gross Vehicle Weight Rating (GVWR), is the maximum number of pounds the trailer can carry, including the fuel cell (empty).
4. **Frame Length** - This measurement is from the ball hitch to the rear bumper (reflector).
5. **Frame Width** - This measurement is from fender to fender.
6. **Jack Stand** - Trailer support device with maximum pound requirement from the tongue of the trailer.
7. **Coupler** - Type of hitch used on the trailer for towing.
8. **Tire Size** - Indicates the diameter of the tire in inches (10,12,14, etc.), and the width in millimeters (175,185,205, etc.). The tire diameter must match the diameter of the tire rim.
9. **Tire Ply** - The tire ply (layers) number is rated in letters; 2-ply,4-ply,6-ply, etc.
10. **Wheel Hub** - The wheel hub is connected to the trailer's axle.
11. **Tire Rim** - Tires mounted on a tire rim. The tire rim must match the size of the tire.
12. **Lug Nuts** - Used to secure the wheel to the wheel hub. Always use a torque wrench to tighten down the lug nuts. See Table 4 and Figure 5 or lug nut tightening and sequence.
13. **Axle** - Indicates the maximum weight the axle can support in pounds, and the diameter of the axle expressed in inches (see Table 3). Please note that some trailers have a double axle. This will be shown as 2-6000 lbs., meaning two axles with a total weight capacity of 6000 pounds.
14. **Suspension** - Protects the trailer chassis from shocks transmitted through the wheels. Types of suspension used are leaf, Q-flex, and air ride.
15. **Electrical** - Electrical connectors (looms) are provided with the trailer so the brake lights and turn signals can be connected to the towing vehicle.
16. **Application** - Indicates which units can be employed on a particular trailer.

DCA-60SSAI —TRAILER-SPECIFICATIONS

Table 1. Specifications

MODEL	APPLICATION	FUEL CELL	BRAKE SYSTEM	GVWR	FRAME LENGTH	FRAME WIDTH	JACK STAND
TRLR-10W	SDW225, SGW250, TLW300	NO	NO	1900LBS	96"	50"	800LB. FULL TILT WHEEL
TRLR-10	DCA10, TLG12, DCA-15	NO	NO	1900LBS	96"	50"	800LB. FULL TILT WHEEL
TRLR-10XF	DCA10, TLG-12, DCA15, TLW-300	52 GAL	NO	1900LBS	96"	50"	800LB. FULL TILT WHEEL
TRLR-225W	WELDERS, DA7000SS	NO	NO	2200LBS	85"	42"	800LB. FULL TILT WHEEL
TRLR-BLW400	BLW-400	NO	ELECTRIC	2700LBS	W/MAST 154" W/O 124"	55" (78" TALL)	800LB. FULL TILT WHEEL
TRLR-50X	DCA-25	NO	NO	2700LBS	124"	55"	800LB. FULL TILT WHEEL
TRLR-50XF	DCA-25	41 GAL	NO	2700LBS	124"	55"	800LB. FULL TILT WHEEL
TRLR-70W	DCA-45, -60, 70	NO	SURGE	7000LBS	186"	77"	2000LB. FLAT PAD
TRLR-70X	DCA-45, -60, 70	OPT	SURGE	7000LBS	138"	66"	2000LB. FLAT PAD
TRLR-70XF	DCA-45, -60, 70	53 GAL	SURGE	7000LBS	138"	66"	2000LB. FLAT PAD
TRLR-100XF	DCA-100, 125	150 GAL	HYDRAULIC SURGE	7000LBS	190"	76"	2000LB. FLAT PAD
TRLR-85/125	DCA-85, 100, 125	145 GAL	HYDRAULIC	10000LBS	186"	77"	2000LB. FLAT PAD
TRLR-150XF	DCA-150, 180	200 GAL	HYDRAULIC SURGE	11160LBS	204"	84"	5000 LB. FLAT PAD
TRLR-220XF	DCA-220	250 GAL	HYDRAULIC SURGE	14000LBS	222"	83"	5000 LB. FLAT PAD
TRLR-300XF	DCA-300	250 GAL	HYDRAULIC SURGE	18000LBS	238"	83"	5000 LB. FLAT PAD
TRLR-400XF	DCA-400	350 GAL	ELECTRIC	18000LBS	238"	83"	5000 LB. FLAT PAD
TRLR-600XF	DCA-600, 800	550 GAL	AIR	30000LBS	384"	96"	5000 LB. FLAT PAD
TRLR-800SX	DCA-600, 800	550 GAL	AIR	30000LBS	384"	96"	5000 LB. FLAT PAD

DCA-60SSAI —TRAILER-SPECIFICATIONS

Table 1. Specifications (Con't)

MODEL	COUPLER	TIRES	WHEELS	AXLE	HUBS	SUSPENSION	ELECTRICAL
TRLR-10W	2" BALL CLASS 2 ADJUSTABLE	175-13C	13"X4.50"	2200# 2X2	5 LUG	3 LEAF	4 WIRE LOOM W/ 4 POLE FLAT
TRLR-10	2" BALL CLASS 2 ADJUSTABLE	175-13C	13"X4.5"	2200#2X2	5 LUG	3 LEAF	4 POLE FLAT
TRLR-10XF	2" BALL CLASS 2 ADJUSTABLE	175-13C	13"X4.5"	2200#2X2	5 LUG	3 LEAF	4 POLE FLAT
TRLR-225W	2" BALL CLASS 2 ADJUSTABLE	175-13B	13X4.5"	2200#2X2	5 LUG	Q FLEX	4 POLE FLAT
TRLR-BLW 400	2" BALL CLASS 2 ADJUSTABLE	175-13C	13 X 4.5"	2200#2X2	5 LUG	3 LEAF	4 POLE FLAT
TRLR-50X	2" BALL CLASS	B78-13LRC	13"X4.50"	3500lbs. 2-3/8"	5 LUG	4 LEAF	4 POLE RUBBER FLAT
TRLR-50XF	2" BALL CLASS	B78-13LRC	13"X4.50"	3500lbs. 2-3/8"	5 LUG	4 LEAF	4 POLE RUBBER FLAT
TRLR-70W	2" BALL CLASS 3" ADJUSTABLE	205-14C BIAS (4)	14"X5"	3500lbs. 3"	5 LUG	5 LEAF	4 POLE RUBBER FLAT
TRLR-70X	2" BALL CLASS 3" ADJUSTABLE	205-14C BIAS (4)	14"X5"	3500lbs 3"	5 LUG	5 LEAF	4 POLE RUBBER FLAT
TRLR-70XF	2" BALL CLASS 3" ADJUSTABLE	205-14C BIAS (4)	14"X5"	3500lbs. 3"	5 LUG	5 LEAF	4 POLE RUBBER FLAT
TRLR-100XF	ADJUSTABLE 2-5/6 OPT 3" EYE	205-15C BIAS (4)	14"X5.5"	3500lbs 3"	5 LUG	5 LEAF	4 WIRE LOOM
TRLR-85/125	ADJUSTABLE 2-5/6 OPT 3" EYE	ST225/75R15D RADIAL (4)	14"x6"	(2)-6000lbs	6 LUG	7 LEAF	4 WIRE LOOM
TRLR-150XF	3" BALL EYE	750-16 E BIAS (4)	16"X7"	(2)-6000lbs	8 LUG	7 LEAF	4 WIRE LOOM
TRLR-220XF	3" EYE ADJUSTABLE	ST235/85R16E RADIAL(4)	16"X7"	(2)-7000lbs	8 LUG	Q FLEX	4 WIRE LOOM
TRLR-300XF	3" EYE ADJUSTABLE	ST235/85R16E RADIAL(6)	16"X7"	(2)-6000lbs	8 LUG	Q FLEX	4 WIRE LOOM
TRLR-400XF	3" EYE ADJUSTABLE	ST235/85R16E RADIAL(6)	16"X7"	(3)-7000lbs.	8 LUG	Q FLEX	4 WIRE LOOM
TRLR-600XF	5TH WHEEL	ST215/75R17.5H RADIAL (8)	16"X7"	(3)-10000lbs	8 LUG	7 LEAF	6 WIRE LOOM
TRLR-800AR	5TH WHEEL	ST215/75R17.5H RADIAL (8)	16"X7"	(3)-10000lbs	8 LUG	AIR-RIDE	6 WIRE LOOM

Brakes

If your trailer has a braking system, the brakes should be inspected the first 200 miles of operation. This will allow the brake shoes and drums to seat properly. After the first 200 mile interval, inspect the brakes every 3,000 miles. If driving over rough terrain, inspect the brakes more frequently.

Electric Brakes

Electrically actuated brakes (Figure 2) are similar to hydraulic brakes. The basic difference is that hydraulic brakes are actuated by an electromagnet.

Listed below are some of the advantages that electric brakes have over hydraulic brakes:

- Brake system can be manually adjusted to provide the corrected braking capability for varying road and load conditions
- Brake system can be modulated to provide more or less braking force, thus easing the brake load on the towing vehicle
- Brake system has very little lag time between the time the vehicle's brakes are actuated and the trailer's brakes are actuated
- Brake system can provide an independent emergency brake system

Remember in order to properly synchronize the tow vehicle's braking to the trailer's braking, can only be accomplished by road testing. Brake lockup, grabbiness or harshness is due to lack of synchronization between the tow vehicle and the trailer being towed or under-adjusted brakes.

Before any brake synchronizations adjustments can be made, the trailer brakes should be burnished-in by applying the brakes 20-30 times with approximately a 20 m.p.h. decrease in speed, e.g. 40 m.p.h. to 20 m.p.h. Allow ample time for brakes to cool between application. This allows the brake shoes to slightly be seated into the brake drum surface.

Figure 2 displays the major electric brake components that will require inspection and maintenance. Please inspect these components as required.

Electric Brake Adjustment

1. Place the trailer on jack stands. Make sure the jack stands are placed on secure level ground.
2. Check the wheel and drum for free rotation.
3. Remove the adjusting hole cover from the adjusting slot at the bottom brake backing plate.
4. With a screwdriver or standard adjusting tool, rotate the star wheel of the adjuster assembly to expand the brake shoes.
5. Adjust the brake shoes outward until the pressure of the lining against the wheel drum makes the wheel difficult to turn.
6. Rotate the star wheel in the opposite direction until the wheel rotates freely with slight lining drag.
7. Replace the adjusting hole cover and lower the trailer to the ground.
8. Repeat steps 1 through 6 on the remaining brakes.

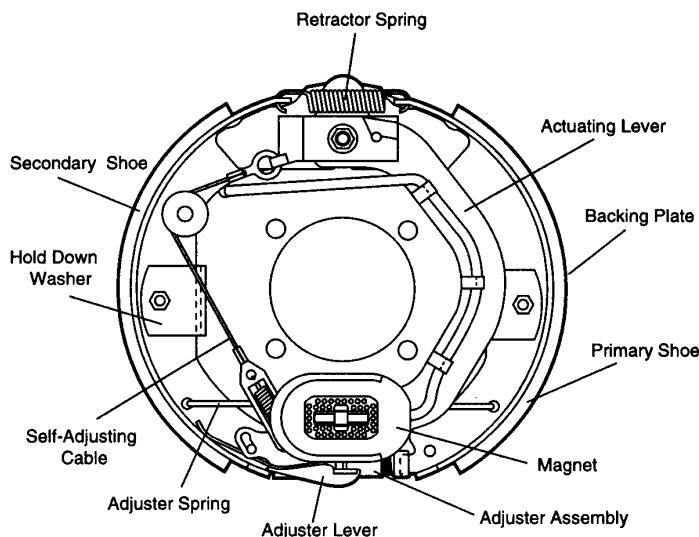

. . . . **Figure 2. Electrical Brake Components**

Hydraulic/Air/Surge Brakes

Hydraulic brakes (Figure 3) should not require any special attention with the exception of routine maintenance such as shoe and lining replacement. These brakes can be adjusted in the same manner as electric brakes. Brake lines should be periodically checked for cracks, kinks, or blockage.

Figure 3 below displays the major hydraulic/air/surge brake components that will require inspection and maintenance. Please inspect these components as required using steps 1 through 6 as referenced in the electric brake adjustments section.

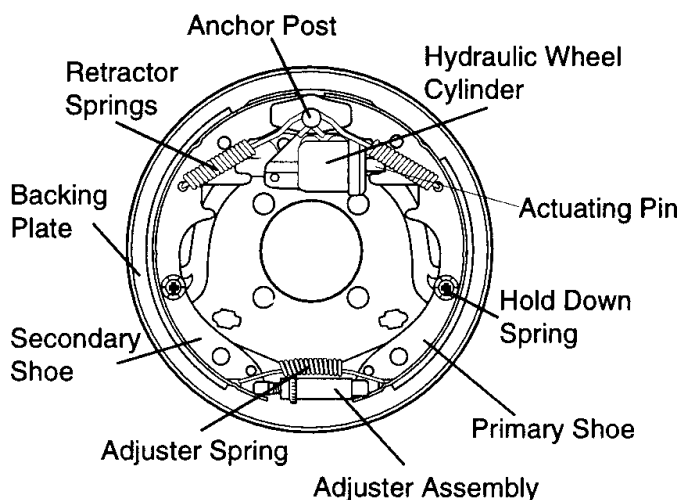

Figure 3. Hydraulic Brake Components

Tires/Wheels/Lug Nuts

Tires and wheels are a very important and critical components of the trailer. When specifying or replacing the trailer wheels it is important the wheels, tires, and axle are properly matched.

CAUTION:



DO NOT attempt to repair or modify a wheel. DO NOT install in inner tube to correct a leak through the rim. If the rim is cracked, the air pressure in the inner tube

may cause pieces of the rim to explode (break off) with great force and cause serious eye or bodily injury.

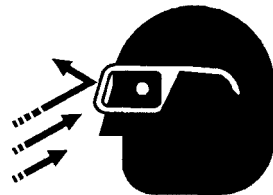

Tire Wear/Inflation

Tire inflation pressure is the most important factor in tire life. Pressure should be checked cold before operation DO NOT bleed air from tires when they are hot. Check inflation pressure weekly during use to insure the maximum tire life and tread wear.

Table 2 (Tire Wear Troubleshooting) will help pinpoint the causes and solutions of tire wear problems.

TABLE 2. TIRE WEAR TROUBLESHOOTING			
WEAR PATTERN		CAUSE	SOLUTION
	Center Wear	Over Inflation.	Adjust pressure to particular load per tire manufacturer.
	Edge Wear	Under Inflation.	Adjust pressure to particular load per tire manufacturer.
	Side Wear	Loss of camber or overloading.	Make sure load does not exceed axle rating. Align wheels.
	Toe Wear	Incorrect toe-in.	Align wheels.
	Cupping	Out-of-balance.	Check bearing adjustment and balance tires.
	Flat Spots	Wheel lockup & tire skidding.	Avoid sudden stops when possible and adjust brakes.

Suspension

The leaf suspension springs and associated components (Figure 4) should be visually inspected every 6,000 miles for signs of excessive wear, elongation of bolt holes, and loosening of fasteners. Replace all damaged parts (suspension) immediately. Torqued suspension components as detailed in Table 3.

CAUTION:

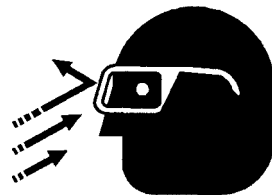

NOTE

ALWAYS wear safety glasses when removing or installing force fitted parts. Failure to comply may result in serious injury.

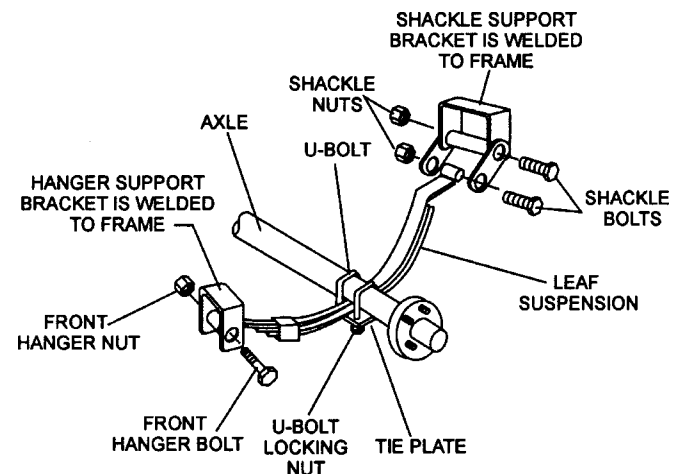

Figure 4. Major Suspension Components

Table 3. Suspension Torque Requirements

Item	Torque (Ft.-Lbs.)
3/8" U-BOLT	MIN-30 MAX-35
7/16" U-BOLT	MIN-45 MAX-60
1/2" U-BOLT	MIN-45 MAX-60
SHACKLE BOLT SPRING EYE BOLT	SNUG FIT ONLY. PARTS MUST ROTATE FREELY. LOCKING NUTS OR COTTER PINS ARE PROVIDED TO RETAIN NUT-BOLT ASSEMBLY.
SHOULDER TYPE SHACKLE BOLT	MIN-30 MAX-50

Lug Nut Torque Requirements

It is extremely important to apply and maintain proper wheel mounting torque on the trailer. Be sure to use only the fasteners matched to the cone angle of the wheel. Proper procedure for attachment of the wheels is as follows:

1. Start all wheel lug nuts by hand.
2. Torque all lug nuts in sequence. See Figure 5. **DO NOT** torque the wheel lug nuts all the way down. Tighten each lug nut in 3 separate passes as defined by Table 4.
3. After first road use, retorque all lug nuts in sequence. Check all wheel lug nuts periodically.

Table 4. Tire Torque Requirements

Wheel Size	First Pass FT-LBS	Second Pass FT-LBS	Third Pass FT-LBS
12"	20-25	35-40	50-65
13"	20-25	35-40	50-65
14"	20-25	50-60	90-120
15"	20-25	50-60	90-120
16"	20-25	50-60	90-120

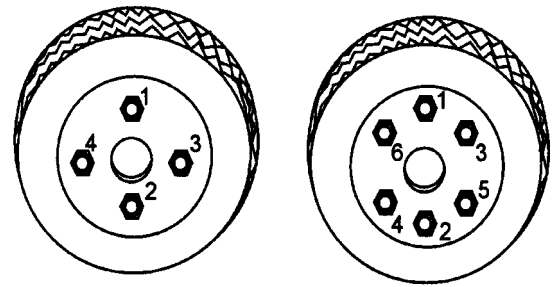

4-LUG NUTS

6-LUG NUTS

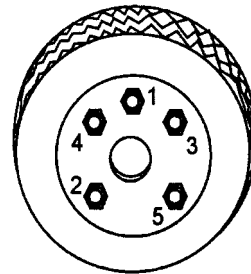

5-LUG NUTS

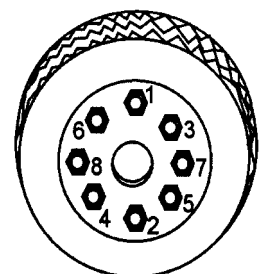

8-LUG NUTS

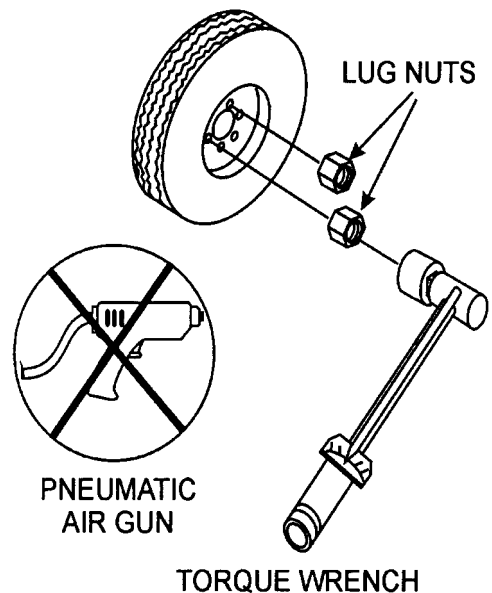

Figure 5. Wheel Lug Nuts Tightening Sequence

NOTE

NEVER use an pneumatic air gun to tighten wheel lug nuts.

DCA-60SSAI —TRAILER-WIRING DIAGRAM

TRAILER SIDE

TOWING VEHICLE SIDE

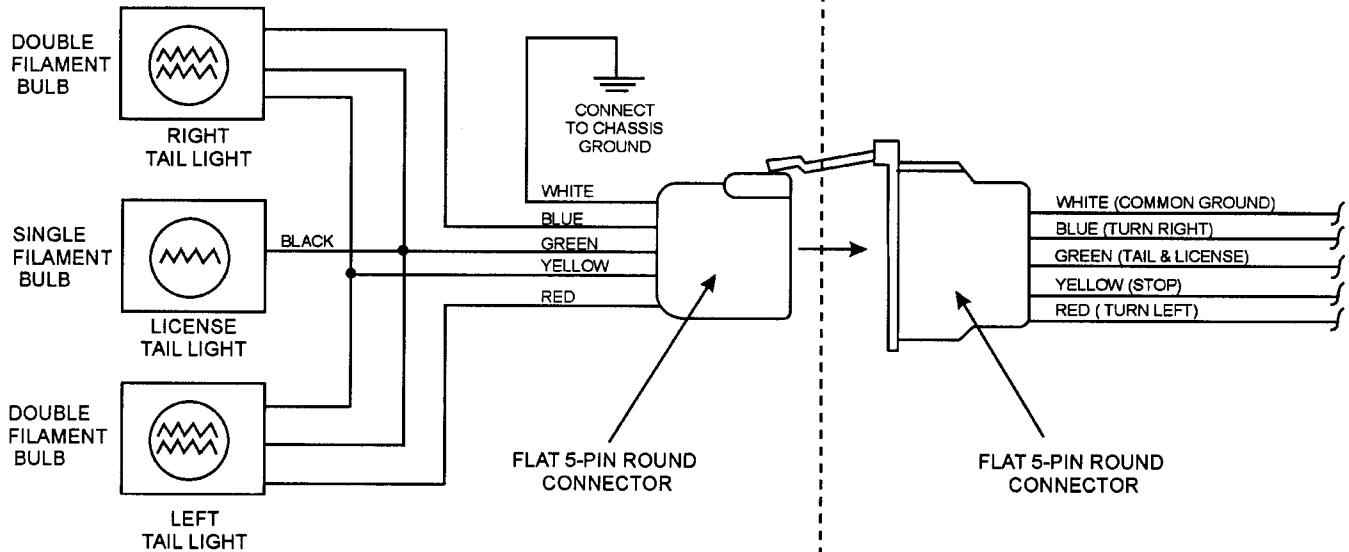
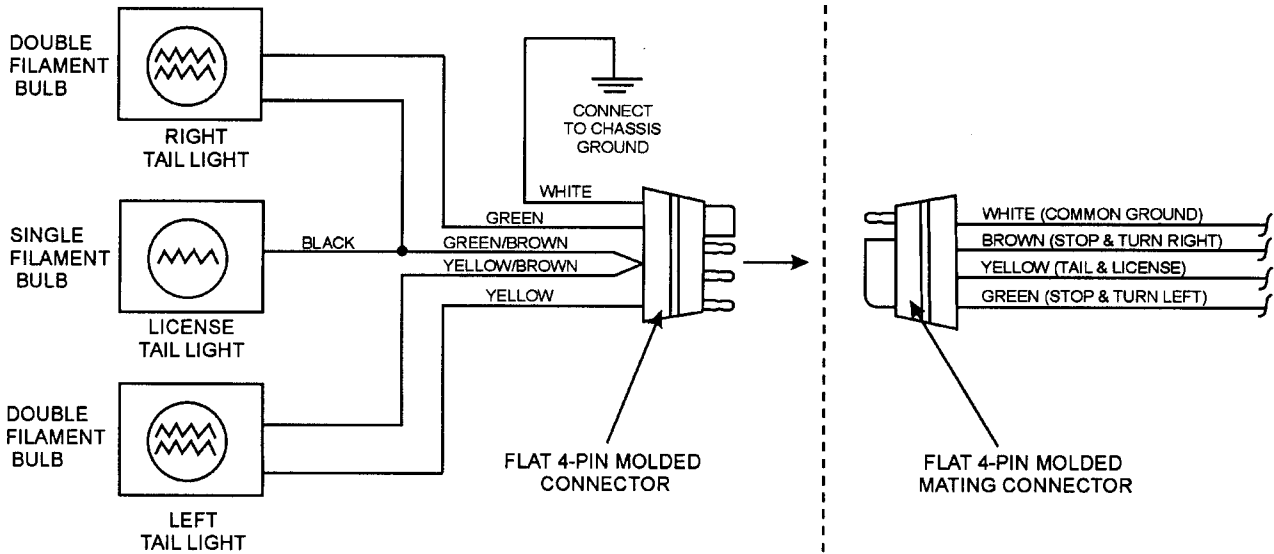

Table 5. Electric Brake Troubleshooting

Symptom	Possible Cause	Solution
No Brakes or Intermittent Brakes	Any open circuits or broken wires?	Find and correct.
	Any short circuits?	Find and correct.
	Faulty controller?	Test and correct.
	Any loose connections?	Find and repair.
	Ground wire secure?	Find and secure.
Weak Brakes or Brakes Pull to One Side	Grease or oil on magnets or linings?	Clean or replace.
	Connections corroded?	Clean and correct cause of corrosion.
	Brake drums scored or grooved?	Machine or replace.
	Brakes synchronized?	Correct.
Locking Brakes	Brake components loose, bent or broken?	Replace components.
	Brake drums out-of-round?	Replace.
Noisy Brakes	System lubricated?	Lubricate.
	Brake components correct?	Replace and correct.
Dragging Brakes	Bearings of the wheel adjusted?	Adjust.

Table 6. Hydraulic Brake Troubleshooting

Symptom	Possible Cause	Solution
No Brakes	Brake line broken or kinked?	Repair or replace.
Weak Brakes or Brakes Pull to One Side	Brake lining glazed?	Reburnish or replace.
	Trailer overloaded?	Correct weight.
	Brake drums scored or grooved?	Machine or replace.
	Tire pressure correct?	Inflate all tires equally.
	Tires unmatched on the same axle?	Match tires.
Locking Brakes	Brake components loose, bent or broken?	Replace components.
	Brake drums out-of-round?	Replace.
Noisy Brakes	System lubricated?	Lubricate.
	Brake components correct?	Replace and correct.
Dragging Brakes	Brake lining thickness correct or in right wrong position?	Install new shoes and linings.
	Enough brake fluid or correct fluid?	Replace rubber parts fill with dot4 fluid.

DCA-60SSAI — GENERATOR DECALS

The DCA -100SSJU generator is equipped with a number of safety decals. These decals are provided for operator safety and maintenance information. The illustration below and on the preceding pages show the decals as they appear on the machine. Should any of these decals become unreadable, replacements can be obtained from your dealer.

OPERATING PROCEDURES

Manual Starting

1. Check the engine oil, coolant, and fuel levels. Replenish if necessary.
2. Place all Generator Circuit Breakers in the "OFF" position and close all doors.
3. Check that the Voltage select switch (or the Voltage change-over board) is present at desired voltage.
(In case of generator having multiple voltage ratings)
4. Set the Engine speed switch to the "LOW" position.
5. Turn the Auto-Off/Reset-Manual switch to the "Manual" position to start the engine. If the engine fails to start in the specified number of attempts, the overcrank lamp will indicate and the Auto-Off/Reset-Manual switch must be returned to the "Off/Reset" position before proceeding.
6. When the engine is ready for starting during cold weather operating conditions, push the Intake Heater button for approximately 30 seconds. Start engine using the Auto-Off/Reset-Manual switch to the "Manual" position. As soon as the engine starts, release the button.
If the engine still does not start, utilize the water heater until water is warm. (If additional water heater is supplied)
7. After starting, allow the engine to run for 1 or 2 minutes to warm-up. At temperatures below freezing, this time period must be extended to 2 to 4 minutes.
8. When the engine starts, immediately check for abnormal noise, vibration, fluid leakage or any indication of a problem. Check the control panel gauges. If all is normal, let the engine remain at the "Low" position for a short time, depending on the ambient conditions, warm up.
9. After sufficient warm-up time has elapsed, set the Engine speed switch to the "High" position and the unit is ready for operation.
10. Check the NO-Load speed as shown in the table below.
60Hz operation—Approx. 50 Ohz (1500rpm)
11. Adjust the Voltage Regulator to the specified voltage.

Manual Stopping

1. Place the Generator Circuit Breakers in the "OFF" position.
2. Set the Engine speed switch to the "LOW" position, and allow the unit to cool for a few minutes.
3. Turn the Auto-Off/Reset-Manual switch, to the "Off/Reset" position.

Auto Starting/Stopping

1. With the Auto/Manual switch in the Auto position, the Auto Starting/Stopping controller monitors remote start contacts. Closure of the remote start contacts will begin engine cranking. When the contacts are opened cranking will stop or if running the engine will stop. All functions of the Automatic shutdown System work as in Manual Starting/stopping.
2. For cold weather conditions utilize the water heater until water is warm. If the engine still does not start, please operate as in Manual Starting.

Emergency Stopping

1. Place the Generator Circuit Breakers in the "OFF" position.
2. Turn the Auto-Off/Reset-Manual switch to the "Off/Reset" position.

M35200010

P/N M3552000103

SAFETY INSTRUCTIONS

Improper operation of this machine can cause severe injury or death.

- Read the instruction manual carefully before operating or servicing.

This machine should only be operated by a person with sufficient knowledge and skill to ensure safe operation.

High voltage circuits are located inside the output terminal cover and control panel.

- Close the cover and control panel before operating.

Moving parts and hot surfaces are contained within the enclosure.

- Close all doors and lock them before operating.

M92010030

P/N M9520100304

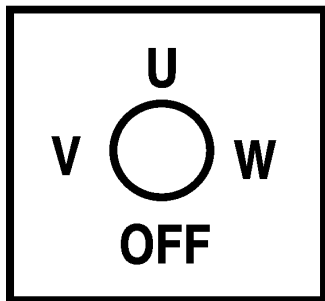

P/N M9520000104

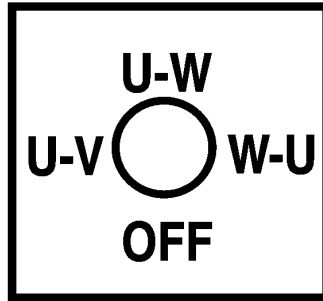

P/N M9520000204



P/N M950000004



P/N M9510200002

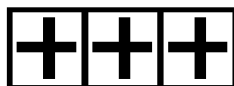

P/N M9500300104

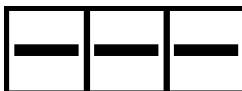

P/N M9500300004

OVER CURRENT RELAY

If it is Impossible to reset the CIRCUIT BREAKER, open the control panel and push the RESET BUTTON as below.

M92020010

P/N M9520200104



P/N M9500500104

DIESEL FUEL

M90050000

P/N M9500500004

WATER • OIL CHECK AND FILL DAILY

M90300010

P/N M9503000103

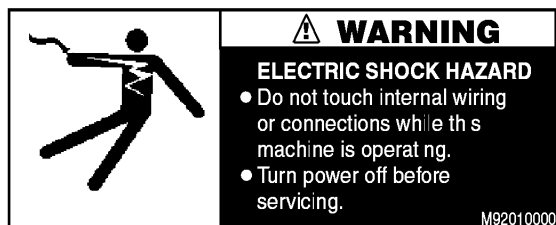

P/N M9520100004



P/N M9520100401

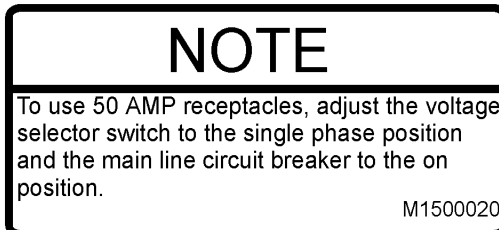

P/N M1550000204

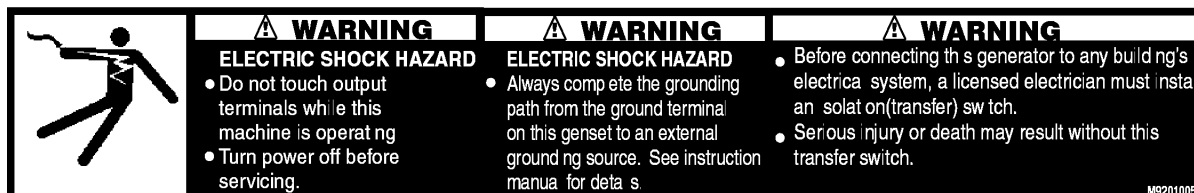

P/N M9520100503

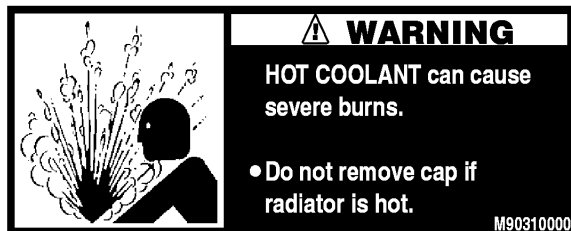

P/N M9503100004

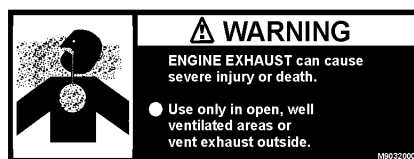

P/N M9503200004



P/N M9520100204

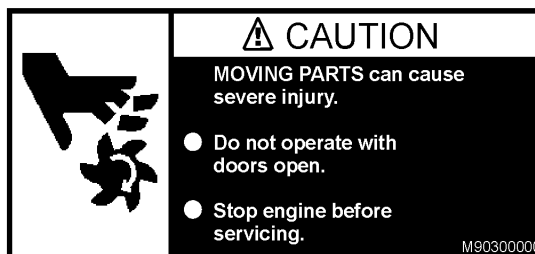

P/N M9503000004

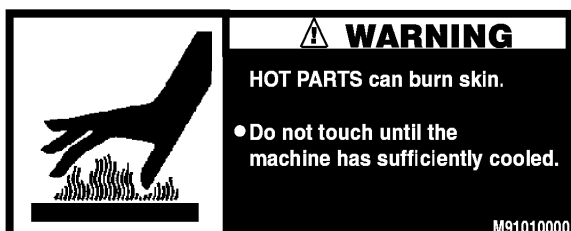

P/N M9510100004

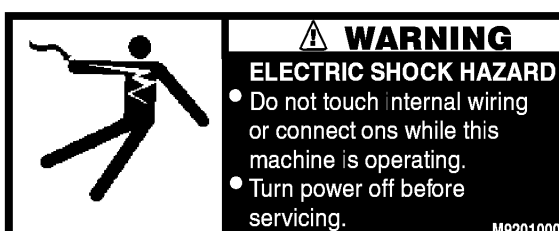

P/N M9520100004

DCA-60SSAI — SPECIFICATIONS

Table 7. Specifications		
Generator Specifications		
Model	DCA-60SSI2	
Type	Revolving field, self ventilated, open protected type synchronous generator	
Armature Connection	Star with Neutral	Zig Zag
Phase	3	Single
Standby Output	72 KVA (57.6 KW)	41.5KW
Prime Output	60 KVA (48 KW)	34.6KW
Voltage	240V or 480V	240/120V
Frequency	60 Hz	
Speed	1800 rpm	
Power Factor	0.8	1
Aux. AC Power	Single Phase, 60 Hz	
Voltage	120 V	
Output	4.8 KW (2.4 KW x 2)	
Engine Specifications		
Model	ISUZU A-6BG1	
Type	4 Cycle, water-cooled, direct injection	
No. of Cylinders	6 cylinders	
Bore x Stroke	4.1 in. x 4.9 in. (105 mm x 125 mm)	
Rated Output	77HP/1800 rpm	
Displacement	396 cu. in. (6494 cc)	
Starting	Electric	
Coolant Capacity	7.8 gal. (29.5 liters)	
Lube Oil Capacity	5.1 gal. (19.3 liters)	
Fuel Consumption	3.9 gal. (14.9L)/hr at full load	3.0 gal. (11.4L)/hr at 3/4 load
	2.4 gal. (9.1L)/hr at 1/2 load	1.9 gal. (7.2L)/hr at 1/4 load
Battery	12V- 100AH x 2	
Fuel	#2 Diesel Fuel	

DCA-60SSAI FAMILIARIZATION

Generator

The MQ Power Model DCA-60SSAI is a 48 kW **generator** that is designed as a high quality portable (requires a trailer for transport) power source for telecom sites, lighting facilities, power tools, submersible pumps and other industrial and construction machinery.

Engine Operating Panel

The "Engine Operating Panel" is provided with the following:

- Tachometer
- Water Temperature Gauge
- Oil Pressure Gauge
- Charging Ammeter Gauge
- Engine Throttle Lever
- Panel Light
- Panel Light Switch
- Oil Pressure and WaterTemp. Indicator lights

Generator Control Panel

The "Generator Control Panel" is provided with the following:

- Output Voltage Adjustment Knob
- Frequency Meter (Hz)
- AC Ammeter (Amps)
- AC Voltmeter (Volts)
- Ammeter Change-Over Switch
- Voltmeter Change-Over Switch

Output Terminal Panel

The "Output Terminal Panel" is provided with the following:

- Three 120/240V output receptacles, 50 amp
- Two 120V input receptacles, 20 amp
- 3 Load Circuit Breakers 240V @50 amps
- 2 Load GFCI Circuit Breakers 120V@ 20amps

Control Box

The "Control Box" is provided with the following:

- Main Circuit Breaker 150 amps
- Over-Current Relay

Open Delta Excitation System

The DCA-60SSAI generator is equipped with the state of the art "**Open-Delta**" excitation system. The open delta system consist of an electrically independent winding wound among stationary windings of the AC output section.

There are four leads: A, B, C and D. During light loads, the power to the **Automatic Voltage Regulator (AVR)** is supplied from the leads parallel connections of B&C. When loads increase, the AVR switches and accepts power from leads A&D. The output of leads A&D increase proportionally with load. This of adding the voltages to each phase provides better voltage response during heavy loads.

The connections of the AVR to the AC output windings are for sensing only. No power is required from these windings.

The open-delta design provides virtually unlimited excitation current, offering maximum motor starting capabilities. The excitation does not have a "**fixed ceiling**" and responds according the demands of the required load.

Engine

The **DCA-60SSAI** is powered by a 4 cycle, water cooled, Isuzu A-6BG1 **diesel** engine. This engine is designed to meet every performance requirement for the generator. Reference Table 1, page13 for engine specifications.

In keeping with Multiquip's policy of constantly improving its products, the specifications quoted herein are subject to change without prior notice.

The basic controls and indicators for the DCA-60SSAI generator are addressed on the following pages.

Mechanical Governor System

The mechanical governor system control the RPM of the engine. When the engine demands increase or decrease, the mechanical governor system regulates the frequency variation to $\pm 1.5\%$. The electronic governor option increases frequency variation to $\pm .25\%$.

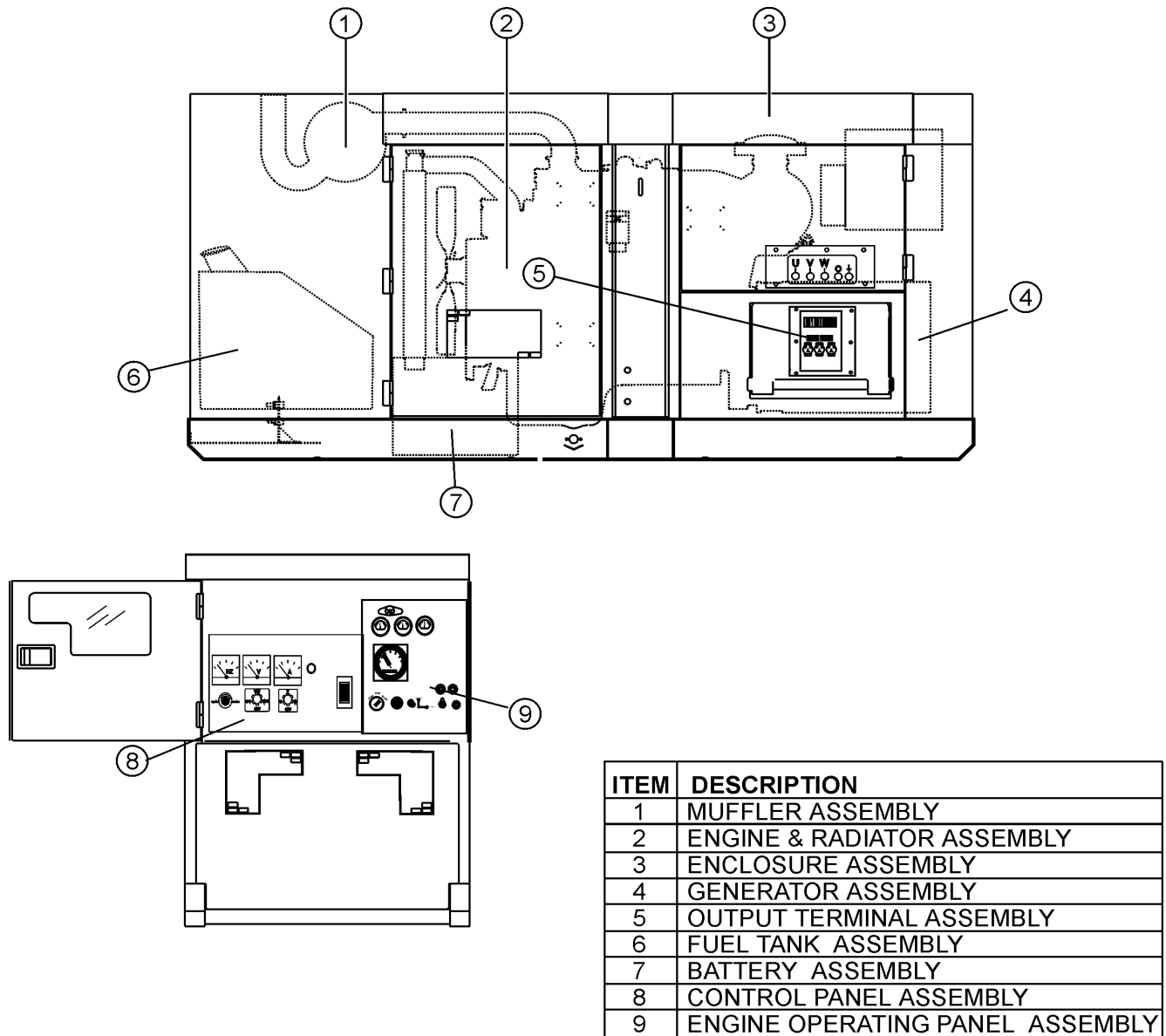

Figure 6. Major Components

DCA-60SSAI — DIMENSIONS (TOP, SIDE AND FRONT)

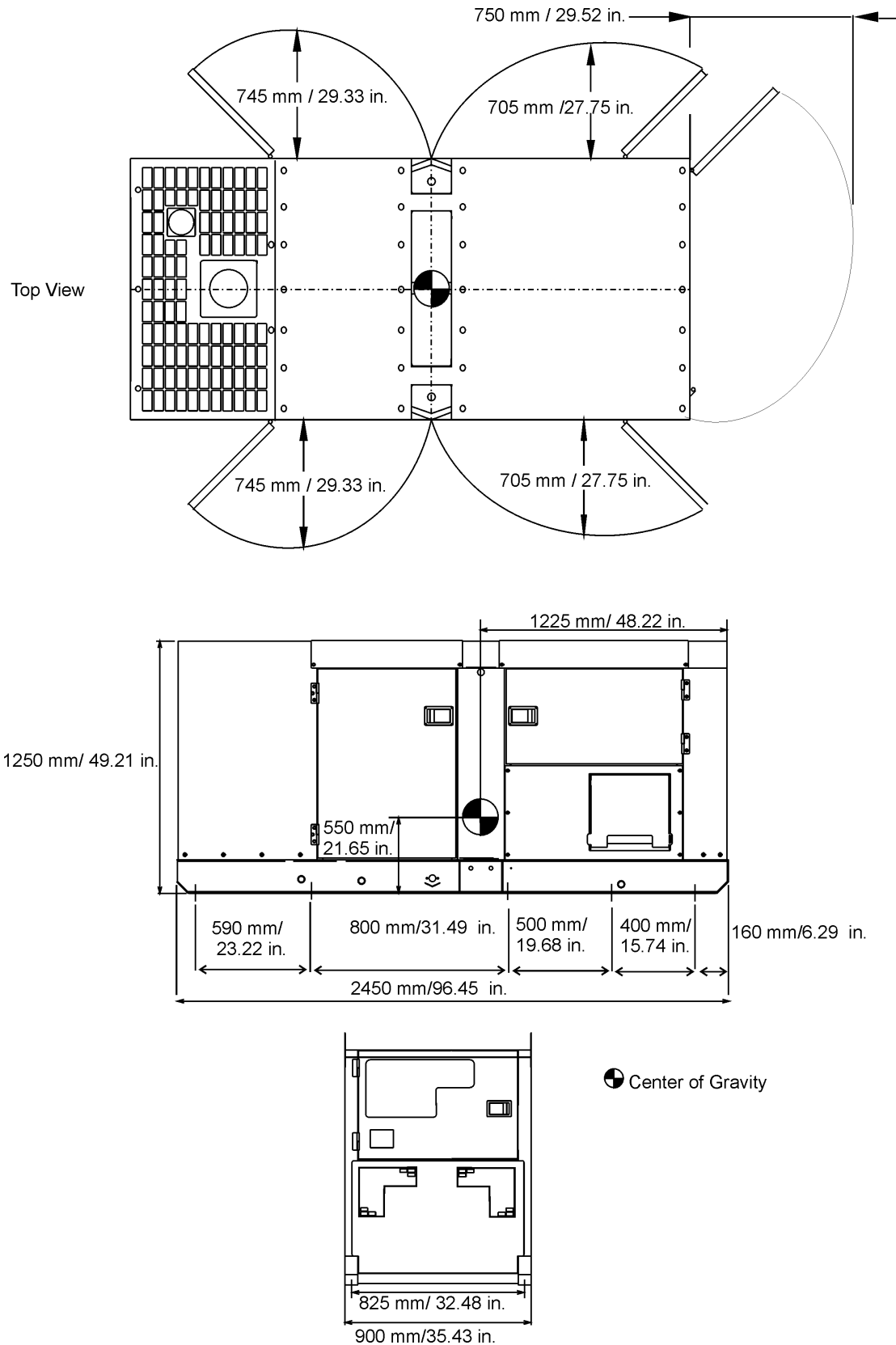
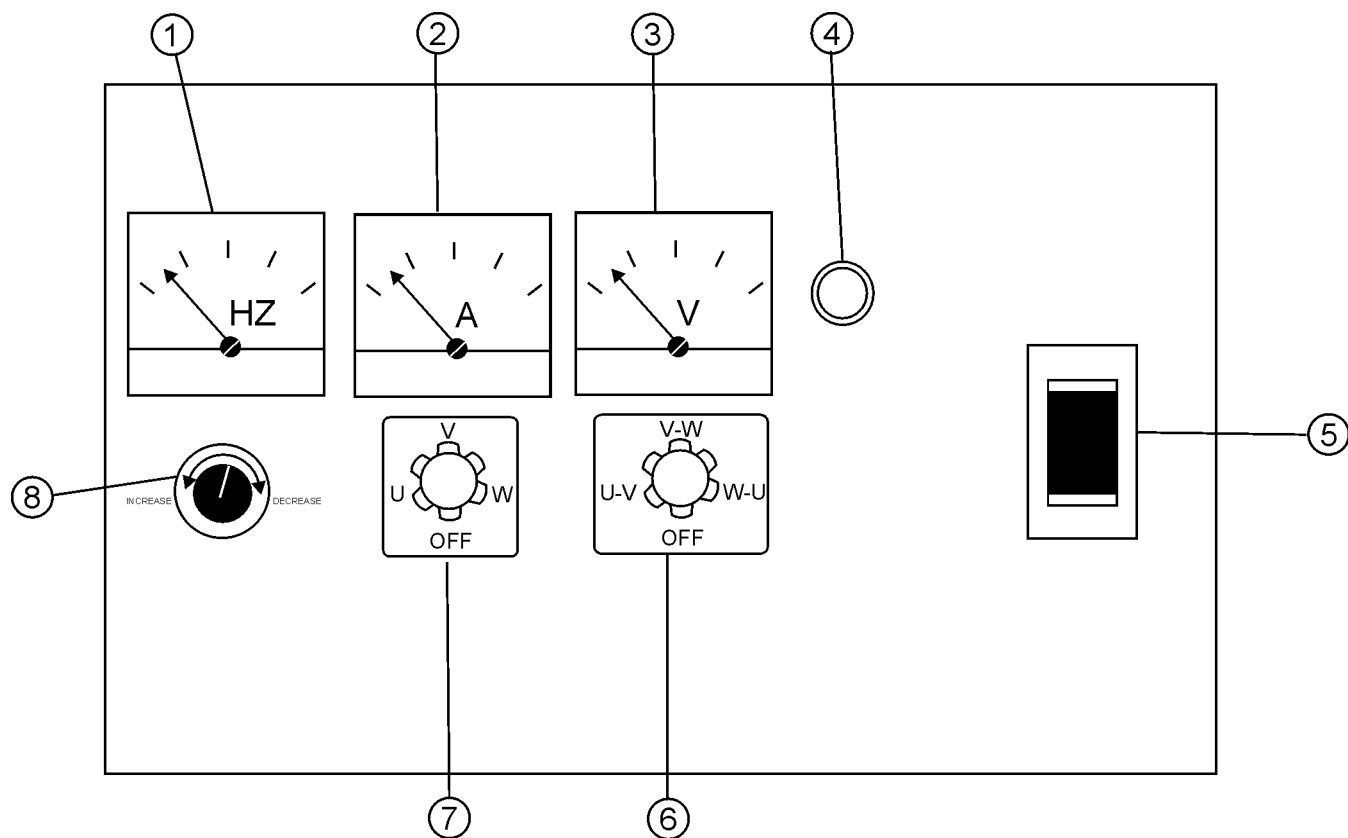

Figure 7. Dimensions



NO	ITEM
1	FREQUENCY METER
2	AC AMMETER
3	AC VOLTMETER
4	PILOT LAMP
5	MAIN CIRCUIT BREAKER
6	VOLTMETER CHANGE-OVER SWITCH
7	AMMETER CHANGE-OVER SWITCH
8	VOLTAGE REGULATOR

Figure 8. Control Panel

The definitions below describe the controls and functions of the DCA-60SSAI " **Control Panel** " (Figure 8).

1. **Frequency Meter** – Indicates the output frequency in hertz (Hz). Normally 60 Hz \pm 1 Hz .
2. **AC Ammeter** – Indicates the amount of current the load is drawing from the generator.
3. **AC Voltmeter** – Indicates the single phase output voltage present at the UNV terminals.
4. **Pilot Lamp** - This lamp indicates the load is not properly set. Readjust the load, or use the voltmeter change-over switch to adjust phase position.
5. **Main Circuit Breaker** – This three-pole, 150 amp main breaker is provided to protect the UNV voltage output terminals from overload.
6. **Voltmeter Change-Over Switch** – This switch allows the AC voltmeter to indicate phase to phase voltage between any two phases of the output terminals or to be switched off.
7. **Ammeter Change-Over Switch** – This switch allows the AC ammeter to indicate the current flowing to the load connected to any phase of the output terminals, or to be switched off.
8. **Voltage Regulator Control** – Allows manual adjustment of the generator's output voltage.

DCA-60SSAI — ENGINE OPERATING PANEL

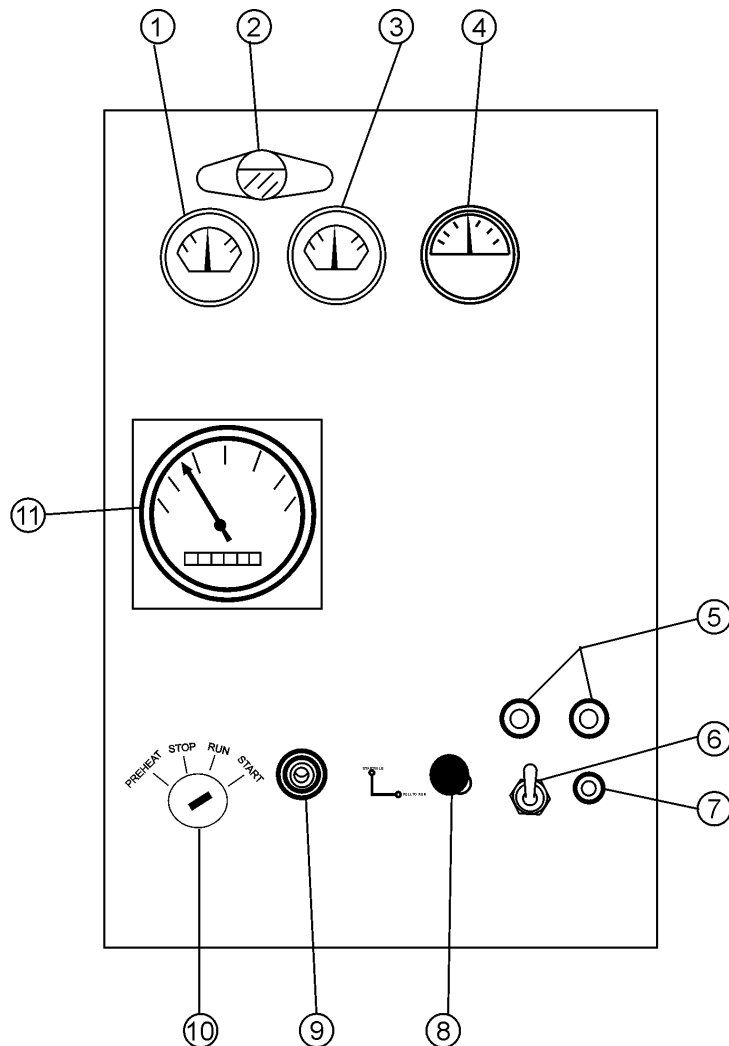

NO	ITEM
1	OIL PRESSURE GAUGE
2	PANEL LIGHT
3	WATER TEMPERATURE GAUGE
4	CHARGING AMMETER
5	INDICATOR LIGHTS
6	PANEL LIGHT SWITCH
7	LAMP CHECK SWITCH
8	ENGINE THROTTLE LEVER
9	PREHEAT INDICATOR
10	STARTER SWITCH
11	TACHOMETER

Figure 9. Engine Operating Panel

The definitions below describe the controls and functions of the DCA-60SSAI " **Engine Operating Panel** " (Figure 9).

1. **Oil Pressure Gauge** – Normal operation should be about 25 psi. When starting the generator the oil pressure may read a bit higher, but after the engine warms up the oil pressure should return to normal.
2. **Panel light** - Normally used in dark places or at night. When activated, panel will luminate. When the generator is not in use, turn the panel light switch to the 'OFF' position.
3. **Water Temperature Gauge** – During normal operation this gauge should read between 165° to 215°.
4. **Charging Ammeter Gauge** – Indicates the current being supplied by the engine's alternator which provides current for generator's control circuits and battery charging system.
5. **Indicator Lights** - These lights indicate if the oil pressure or water temperature is at dangerous levels and will shut off the engine. The oil pressure indicator will initially light at start-up, but will go off once the pressure rises.
6. **Panel light switch**- When activated, will turn on control panel light.
7. **Lamp Check Switch** - This is used to check the indicator lights. Turn on the engine, then press this to check the bulbs. If they don't light, replace the bulbs.
8. **Engine Throttle Lever** - Pull or push this lever to change the speed of the engine when a load is applied.
9. **Pre-Heat Indicator** – Under cold conditions, turn the starter key to preheat. Once the indicator lights, the engine is ready to start.
10. **Starter Switch** - Turn this to start, stop, and preheat the engine.
11. **Tachometer** – Indicates engine speed in RPM's for 60 Hz operation. This meter should indicate 1800 RPM's when the engine is at full speed and a load is applied. In addition, a built in hour meter will record the number of operational hours that the generator has been in use.

Output Terminal Panel

The output control panel is located on the rear (control panel) end of the generator. The UNV lugs are protected by a face plate cover that can be secured in the close position by a pad lock.

120 Volt Receptacle

One GFCI Duplex NEMA 5-20R (120V, 20 Amp) receptacle is located on the output terminal. This receptacle can be used anytime the generator is in operation. The receptacle is controlled by the circuit breaker located on the control panel.

The reset button will reset the receptacle after being tripped. Pressing the "Test Button" (Figure 8) in the center of this receptacle will check the GFCI function. The receptacle should be tested at least once a month.

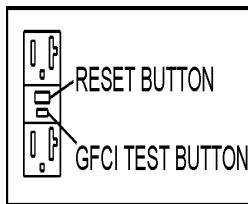

Figure 10. GFCI Test Button

Generator Grounding

Make sure the generator is properly grounded before applying load. Generators are NOT considered grounded when mounted on a trailer.

Twist Lock Dual Voltage Receptacles - To use these receptacles, place the voltage selector switch in the single phase 240/120 voltage position and adjust the output voltage to 240 volts with the voltage regulator on the Control Panel (Figure 8, page 28). Place the voltmeter change-over switch to the U-W position and the ammeter change-over switch to the U or W to read the output.

Connecting Load

Loads can be connected to the generator by the UVWO lugs or the duplex receptacles. (See figure 3). Make sure to read the operation manual before attempting to connect a load to the generator.

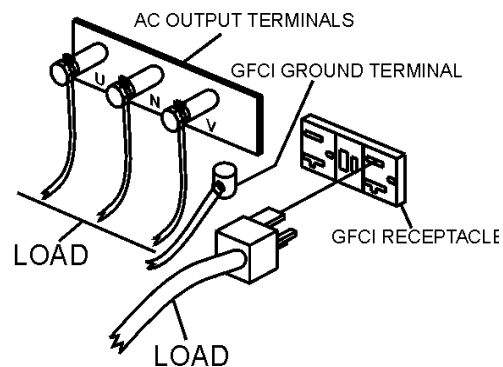

Figure 11. Load Application

Circuit Breakers

To protect the generator from an overload, a 3-pole, 150 amp, **main** circuit breaker is provided to protect the UVWO output terminals from overload. In addition two single-pole, 20 amp **GFCI** circuit breakers are provided to protect the GFCI receptacles from overload. Three 50 amp **load** circuit breakers have also been provided to protect the load side of the generator from overload. Make sure to switch **ALL** circuit breakers to the "OFF" position prior to starting the engine.

Maximum Output

The entire load connected to the UVWO lugs, all four slots in the duplex receptacles, and the must not exceed 52.8 kW in standby or 48 kW in prime output.

Generator Grounding

Make sure to ground the generator in **EVERY** application prior to connecting a load. Generators are **NOT** grounded just because they are mounted on trailers or other vehicles that are on rubber tires.

DCA-60SSAI — OUTPUT TERMINAL VOLTAGE SELECTION

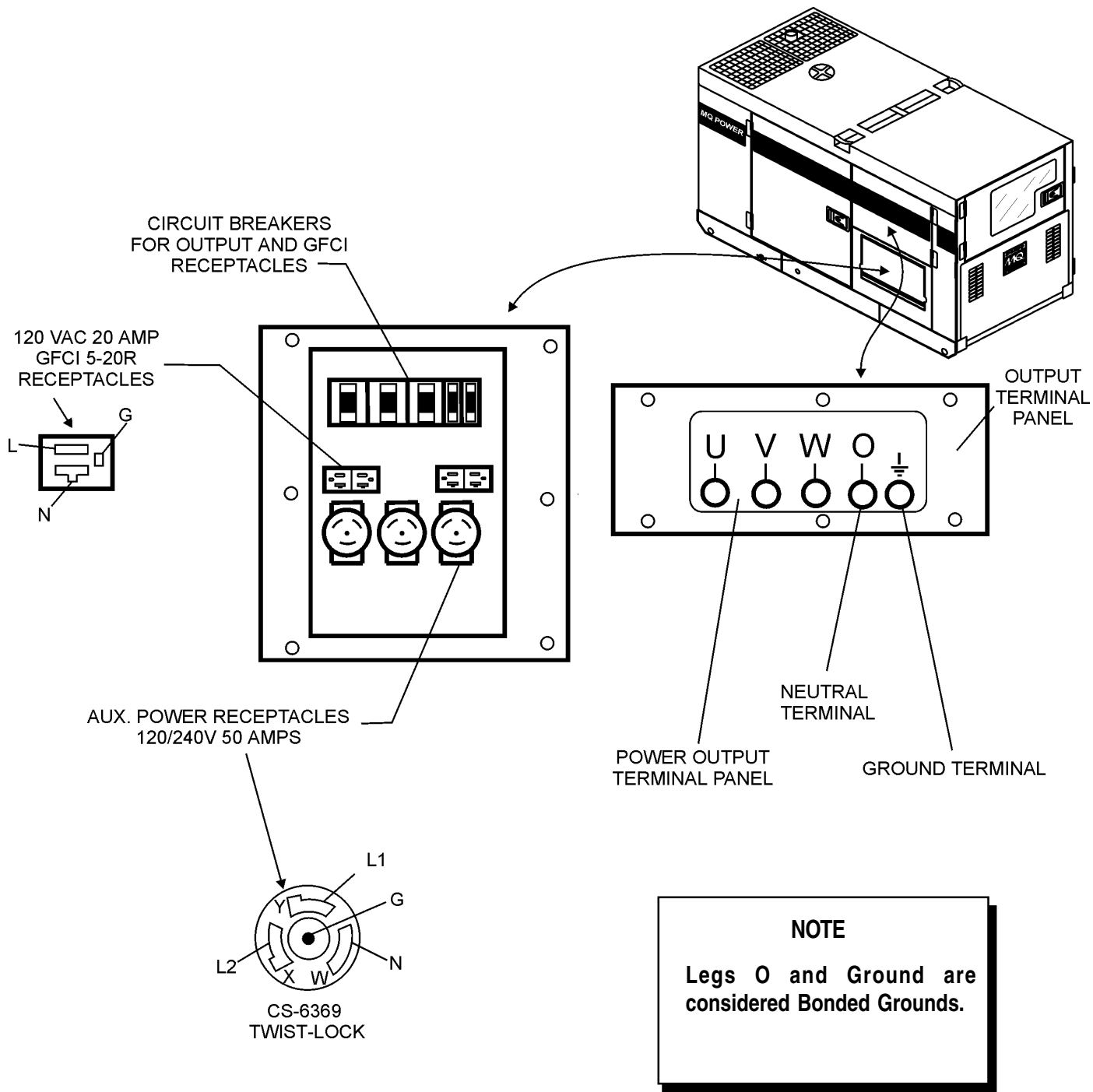

Figure 12. Output Panel Location

DCA-60SSAI — OUTPUT AMPERAGE SETUP

Output Terminal Panel Available Voltages

A wide range of voltages are available to supply load to many different applications. Voltages may be selected by using the voltage selector switch and depending how you hookup your hard wire connection to the generator. To obtain some of the voltages listed, fine adjustment with the voltage regulator on the control panel is necessary. See Table 8 for available voltages the generator will supply.

Over Current Relay

An over current relay is connected to the circuit breaker. During an over current situation, both the circuit breaker and the over current relay will trip. If the circuit breaker can not be reset, the reset button on the over current relay must be pressed. The over current relay is located inside the control box.

Table 8. Voltage Available

3 Phase (Switchable)	208 VOLT	220 VOLT	240 VOLT	416 VOLT	440 VOLT	480 VOLT
Single Phase (Switchable)	120 VOLT	127 VOLT	139 VOLT	240 VOLT	254 VOLT	277 VOLT

CAUTION :



NEVER switch Voltage Selector Switch position while the engine is engaged.

Voltage Selector Switch Locking Button

The voltage selector switch has a locking button to protect the generator and generator load from being switched while the engine is running. To lock the voltage selector switch, press in the red button located on the voltage selector switch, and use a pad lock to hold it into this position.

Maximum Amps

Table 9 shows the maximum amps the generator will provide. Do not exceed the maximum amps listed.

Table 9. Maximum Amps

Rated Voltage	Maximum Amps
Single Phase 120 Volt	133.3 amps (4 wire)
Single Phase 240 Volt	66.7 amps (4 wire)
Three Phase 240 Volt	144 amps
Three Phase 480 Volt	72 amps

Receptacle Use

When the UVWO terminals are providing power, the receptacle power availability will decrease.

How To Read The Output Terminal Gauges.

The gauges (Figure 15 and 17) and change-over switches on the control panel DO NOT effect the generator output. They are to help observe how much power is being supplied at the UVWO legs.

When the voltage selector switch is in the 240/120V position (Figure 13), place the AC voltmeter change-over switch to the W-U position (Figure 14) and the AC ammeter change-over switch to the U or W position (Figure 16) to read the output on the selected leg.

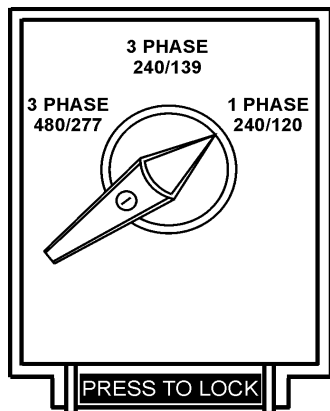

Figure 13. Voltage Selector Switch 240/120V Single Phase Position

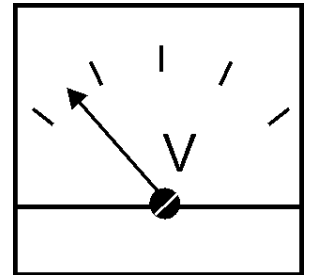
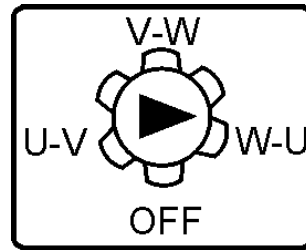

Figure 14 and 15. AC Voltmeter Change-over switch and Voltmeter Gauge

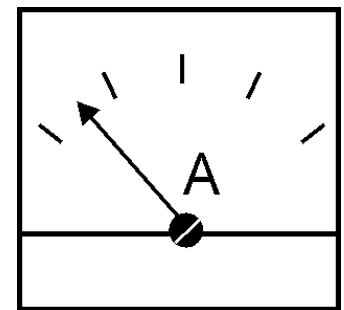
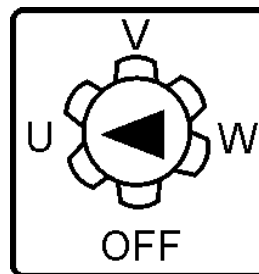

Figure 16 and 17. AC Ammeter Change-over Switch and Ammeter Gauge

NOTE

When using plural single phase voltages, make sure to balance the load on each of the single phase legs.

Voltage Selector Switch- 3 Phase 480/277V Position

The following are additional voltages available when the voltage selector switch is in the '3 phase 480/277V' position.

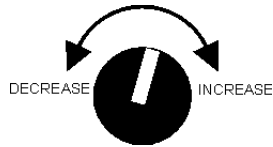

Figure 21. Voltage Regulator Knob

3 Phase, 480V, 440V, or 416 Volt

This setting can provide 3-phase power at 480, 440, or 416 volts. After hooking up the hard wires to the lugs as shown in Figure 22, 480 volts can be obtained with the voltage regulator knob turned toward maximum; 440 volts can be obtained with the voltage regulator knob is turned down; and 416 volts can be obtained with the voltage regulator knob is at the lowest setting.

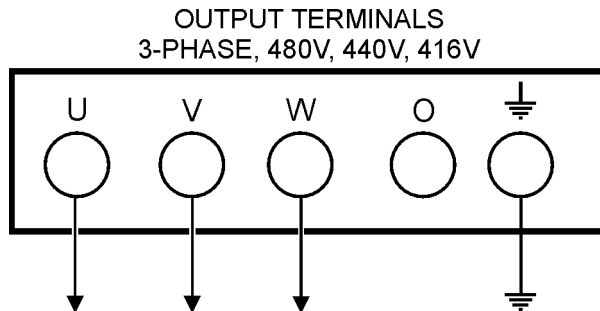

Figure 22. Hard Wire Hookup for Three Phase 480V, 440V, or 416V

Single Phase: 480V, 440V, or 416 Volt

This setting can provide single phase power at 480, 440, or 416 volts. After hooking up the hard wires to the lugs as shown in Figure 23, 480 volts can be obtained with the voltage regulator knob turned toward maximum; 440 volts can be obtained with the voltage regulator knob is turned down; and 416 volts can be obtained with the voltage regulator knob is at the lowest setting.

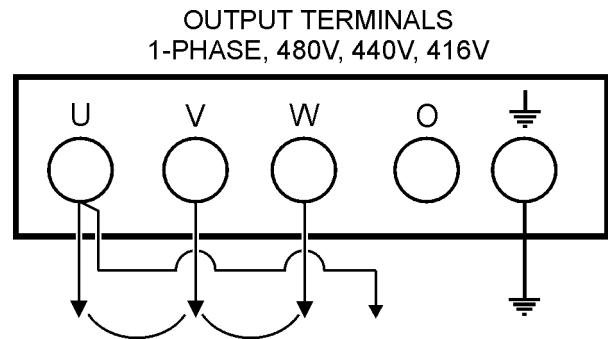

Figure 23. Hard Wire Hookup for Single Phase 480V, 440V, or 416V

Single Phase: 277V, 254V, or 240V

This setting can provide single phase power at 277, 254, or 240 volts. After hooking up the hard wires to the lugs as shown in Figure 24, 277 volts can be obtained with the voltage regulator knob turned toward maximum; 254 volts can be obtained with the voltage regulator knob is turned down; and 240 volts can be obtained with the voltage regulator knob is at the lowest setting.

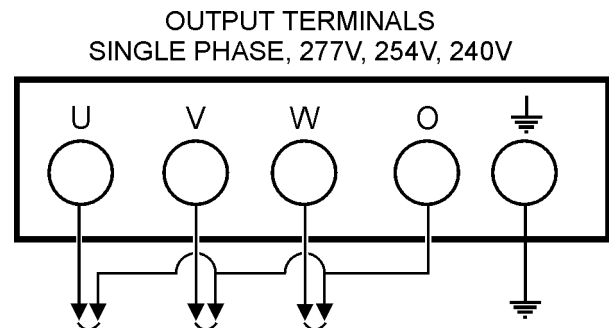

Figure 24. Hard Wire Hookup for Single Phase 277V, 254V, or 240V

Voltage Selector Switch- 3 Phase 240/139V Position

The following are additional voltages available when the voltage selector switch is in the '3 phase 240/139V' position.

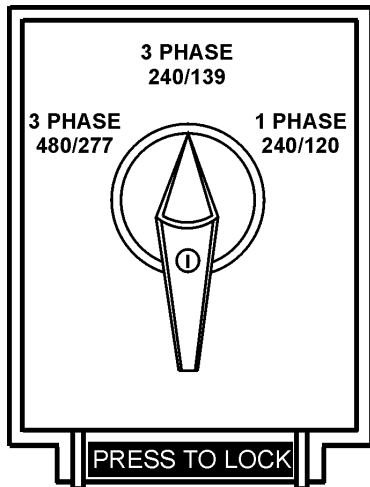

Figure 25. Voltage Selector Switch 240/139V Three Phase Position

3 Phase, 240V, 220V, or 208 Volt

This setting can provide 3-phase power at 240, 220, or 208 volts. After hooking up the hard wires to the lugs as shown in Figure 26, 240 volts can be obtained with the voltage regulator knob turned toward maximum; 220 volts can be obtained with the voltage regulator knob is turned down; and 208 volts can be obtained with the voltage regulator knob is at the lowest setting.

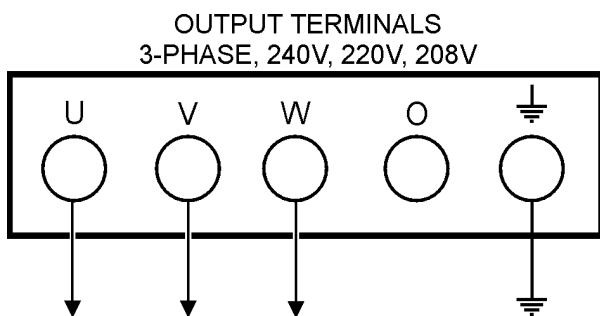

Figure 26. Hard Wire Hookup for Three Phase 240V, 220V, or 208V

Single Phase: 240V, 220V, or 208 Volt

This setting can provide single phase power at 240, 220, or 208 volts. After hooking up the hard wires to the lugs as shown in Figure 27, 240 volts can be obtained with the voltage regulator knob turned toward maximum; 220 volts can be obtained with the voltage regulator knob is turned down; and 208 volts can be obtained with the voltage regulator knob is at the lowest setting.

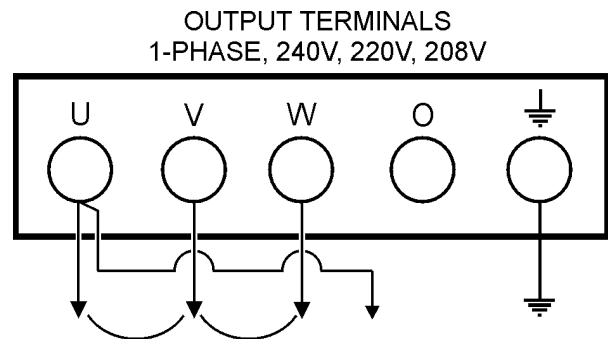

Figure 27. Hard Wire Hookup for Single Phase 240V, 220V, or 208V

Single Phase: 139V, 127V, or 120V

This setting can provide single phase power at 139, 127, or 120 volts. After hooking up the hard wires to the lugs as shown in Figure 28, 139 volts can be obtained with the voltage regulator knob turned toward maximum; 127 volts can be obtained with the voltage regulator knob is turned down; and 120 volts can be obtained with the voltage regulator knob is at the lowest setting.

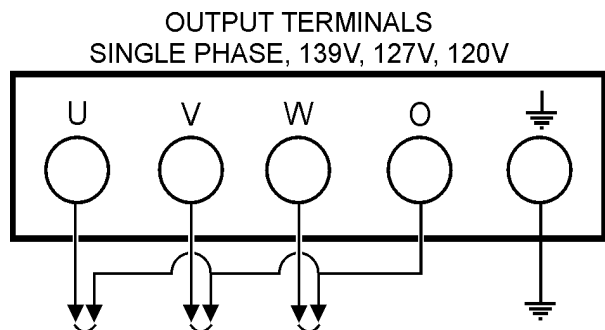

Figure 28. Hard Wire Hookup for Single Phase 139V, 127V, or 120V

Voltage Selector Switch- Single Phase 240/120V

Position

The following are additional voltages available when the voltage selector switch is in the 'single phase 240/120V' position.

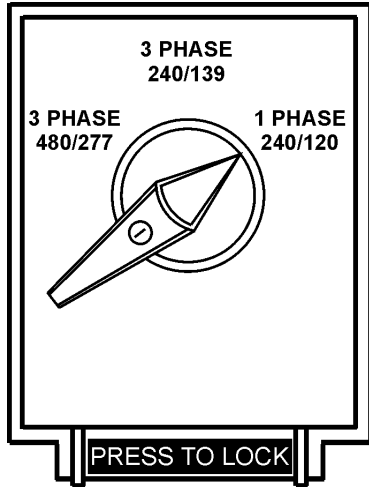

Figure 29. Voltage Selector Switch 240/120V Single Phase Position

Single Phase: 120 Volt

This setting can provide single phase power at 120 volts. After hooking up the hard wires to the lugs as shown in Figure 31, 120 volts can be obtained with the voltage regulator knob turned to fine tune.

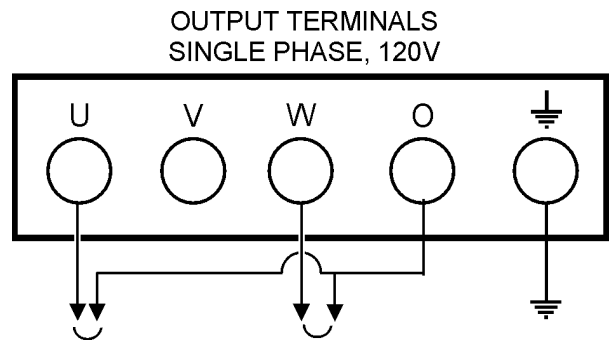

Figure 31. Hard Wire Hookup for Single Phase, 120 volt

Single Phase, 240 Volt

This setting can provide single phase power at 240 volts. After hooking up the hard wires to the lugs as shown in Figure 30, 240 volts can be obtained with the voltage regulator knob turned to fine tune.

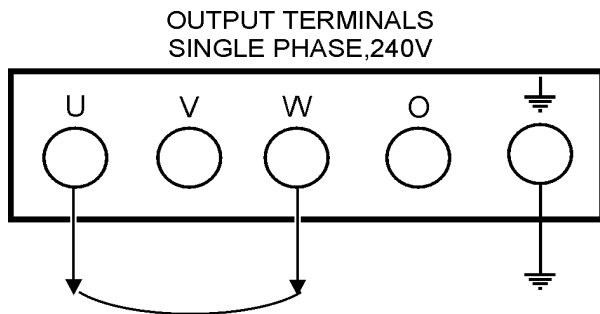

Figure 30. Hard Wire Hookup for Single Phase 240 volt

Outdoor Installation

Install the generator in a location where it will not be exposed to rain or sunshine. Make sure the generator is on secure level ground so it cannot slide or shift around. Also install the generator so the exhaust will not be discharged in the direction of nearby homes.

The installation site must be relatively free from moisture and dust. All electrical equipment should be protected from excessive moisture. Failure to do will result in deterioration of the insulation and will result in short circuits and grounding.

Foreign materials such as dust, sand, lint and abrasive materials have a tendency to cause excessive wear to the engine and alternator parts.

CAUTION :



Pay close attention to ventilation when operating the generator inside tunnels and caves. The engine exhaust contains noxious elements. Engine exhaust must be routed to a ventilated area.

Indoor Installation

Exhaust gases from diesel engines are extremely poisonous. Whenever an engine is installed indoors the exhaust fumes must be vented to the outside. The engine should be installed at least two feet from any outside wall. Using an exhaust pipe which is too long or too small can cause excessive back pressure which will cause the engine to heat excessively and possibly burn the valves.

CAUTION :

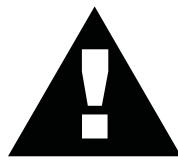

An electric shock may happen when vibrators are used. Pay close attention to handling when operating vibrators and always use rubber boots and gloves to insulate the body from electrical shock.

Generator Grounding

To guard against electrical shock and possible damage to the equipment, it is important to provide a good **EARTH** ground.

Article 250 (Grounding) of the National Electrical Code (NEC) provides guide lines for proper grounding and specifies that the cable ground shall be connected to the grounding system of the building as close to the point of cable entry as practical.

NEC articles 25064(b) a and 250-66 set the following grounding requirements:

1. Use one of the following wire types to connect the generator to earth ground.
 - a. Copper - 10 AWG (5.3 mm²) or larger.
 - b. Aluminum - 8 AWG (8.4 mm²) or larger.
2. When grounding the generator (Figure 32) connect the ground cable between the lock washer and the nut on the generator and tighten the nut fully. Connect the other end of the ground cable to earth ground.
3. NEC article 250-52(c) specifies that the earth ground rod should be buried a minimum of 8 ft. into the ground.

NOTE

When connecting the generator to any buildings electrical system **ALWAYS** consult with a licensed electrician.

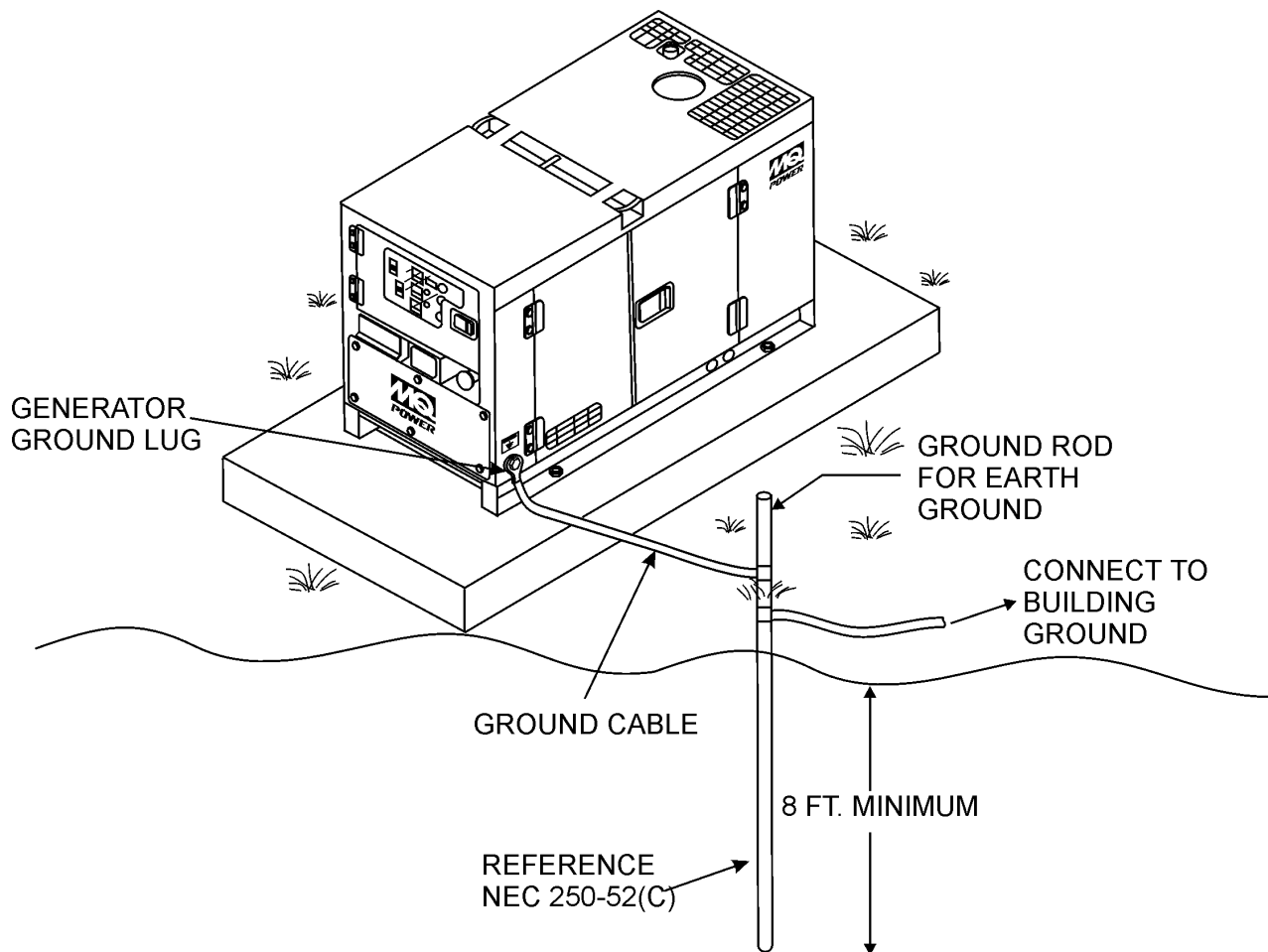

Figure 32. Typical Generator Grounding Application

General Inspection Prior to Operation

The DCA-60SSAI generator has been thoroughly inspected and accepted prior to shipment from the factory. However, be sure to check for damaged parts or components, or loose nuts and bolts, which could have occurred in transit.

Extension Cable

When electric power is to be provided to various tools or loads at some distance from the generator, extension cords are normally used. Cables should be sized to allow for distance in length and amperage so that the voltage drop between the generator and point of use (load) is held to a minimum. Use the Cable Selection Guide (Table 10) as a guide for selecting proper cable size.

Circuit Breakers

To protect the generator from an overload, a 3-pole, 150 amp, **main** circuit breaker is provided to protect the UNV output terminals from overload. In addition two single-pole, 20 amp **GFCI** circuit breakers are provided to protect the GFCI receptacles from overload. Three 50 amp **load** circuit breakers have also been provided to protect the load side of the generator from overload. Make sure to switch **ALL** circuit breakers to the "OFF" position prior to starting the engine.

NOTE

ALWAYS consult with a licensed electrician for correct extension cord wire size.

Table 10. Cable Selection (60 Hz, Single Phase Operation)

Current in Amperes	Load In Watts		Maximum Allowable Cable Length			
	At 120 Volts	At 240 Volts	#10 Wire	#12 Wire	#14 Wire	#16 Wire
2.5	300	600	1000 ft.	600 ft.	375 ft.	250 ft.
5	600	1200	500 ft.	300 ft.	200 ft.	125 ft.
7.5	900	1800	350 ft.	200 ft.	125 ft.	100 ft.
10	1200	2400	250 ft.	150 ft.	100 ft.	
15	1800	3600	150 ft.	100 ft.	65 ft.	
20	2400	4800	125 ft.	75 ft.	50 ft.	

CAUTION: Equipment damage can result from low voltage.

Lubrication Oil

Fill the engine crankcase with lubricating oil through the filler hole, but do not overfill. Make sure the generator is level. With the dipstick inserted all the way, but without being screw into the filler hole, verify that the oil level is maintained between the two notches (Figure 33) on the dipstick. See Table 11 for proper selection of engine oil.

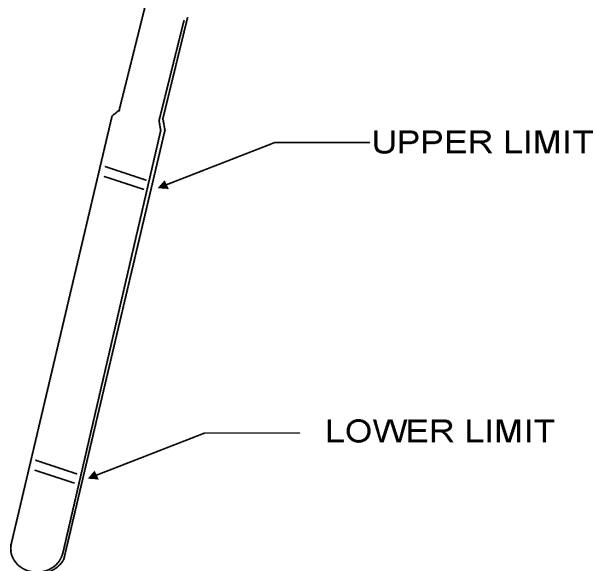

Figure 33. Engine Oil Dipstick

When checking the engine oil, be sure to check if the oil is clean and viscous. If the oil is not clean, drain the oil by removing the oil drain plug, and refill with the specified amount of oil as outlined in the **Isuzu Engine Owner's Manual**.

Fuel

Fill the fuel tank with clean and fresh **diesel fuel**. **DO NOT** fill the tank beyond capacity.

Pay attention to the fuel tank capacity when replenishing fuel. Refer to the fuel tank capacity listed on page 23, Specification Table 7.

The fuel tank cap must be closed tightly after filling. Handle fuel in a safety container. If the container does not have a spout, use a funnel. Wipe up any spilled fuel immediately.

CAUTION:



Never fill the fuel tank while the engine is running or in the dark. Diesel spillage on a hot engine can cause a fire or explosion. If diesel spillage occurs, wipe up the spilled diesel completely to prevent fire hazards.

Coolant

Use only drinkable tap water. If hard water or water with many impurities is used, the inside of the engine and radiator may become coated with deposits and cooling efficiency will be reduced.

An anticorrosion additive added to the water will help prevent deposits and corrosion in the cooling system. See the engine manual for further details.

Table 11. Recommended Motor Oil

Temperature Range	Type Oil
104° F ~ 23° F (40° C ~ -5°C)	SAE 30
23° F ~ 5° F (-5° C ~ -15°C)	SAE 20 or SAE 10W-30
Below 5° C (-15°)	SAE 10W or SAE 10W-30

CAUTION :



When adding coolant or antifreeze to the radiator, do not remove the radiator cap until the unit has completely cooled.

Day-to-day addition of coolant is done from the reserve tank. When adding coolant to the radiator, **DO NOT** remove the radiator cap until the unit has completely cooled. See Table 12. for engine, radiator, and reserve tank coolant capacities. Make sure the coolant level in the reserve tank is always between the "H" and the "L" markings.

Table 12. Coolant Capacity

Engine and Radiator	7.8 Gal. (29.5 Liter)
Reserve Tank	.95 Gal. (2 Liter)

Operation in Freezing Weather

When operating in freezing weather, be certain the proper amount of antifreeze (Table 13) has been added.

Table 13. Anti-Freeze Operating Temperatures

Vol % Anti-Freeze	Freezing Point		Boiling Point	
	°C	°F	°C	°F
40	-24	-12	106	222
50	-37	-34	108	226

NOTE

When the antifreeze is mixed with water, the antifreeze mixing ratio must be less than 50%.

Cleaning the Outer Radiator

The engine may overheat if the radiator fins become overloaded with dust or debris. Periodically clean the radiator fins with compressed air. Cleaning inside the radiator is dangerous, so clean only with the engine turned off and the battery disconnected.

Air Cleaner

Periodic cleaning/replacement is necessary. Inspect it in accordance with the **Isuzu Engine Owner's Manual**.

Fan Belt Tension

A slack fan belt may contribute to overheating, or to insufficient charging of the battery. Inspect the fan belt for damage and wear and adjust it in accordance with the **Isuzu Engine Owner's Manual**.

The fan belt tension is proper if the fan belt bends 10 to 15 mm (Figure 34) when depressed with the thumb as shown below. Never place hands near the belts or fan while the generator is running.

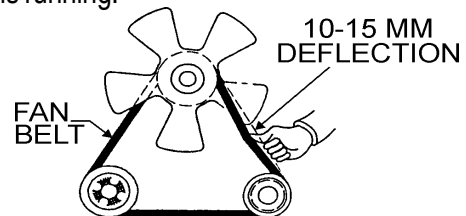

Figure 34. Fan Belt Tension

CAUTION :



Never place hands near the belts or fan while the generator set is running.

Adjusting Fan Belt

If the fan belt does not have the 10 to 15 mm deflection follow the procedure below to adjust:

Loosen the alternator adjusting plate and alternator mounting bolt.

Pivot the alternator at the mounting bolt toward the engine left or right until the belt reflects the proper tension.

Tighten the mounting bolt and the adjusting bolt.

Battery

This unit is of negative ground. **DO NOT** connect in reverse. Always maintain battery fluid level between the specified marks. Battery life will be shortened, if the fluid level is not properly maintained. Add only distilled water when replenishment is necessary. **DO NOT** over fill.

The battery is sufficiently charged if the specific gravity of the battery fluid is 1.28 (at 68° F). If the specific gravity should fall to 1.245 or lower, it indicates that the battery is dead and needs to be recharged or replaced.

Check to see whether the battery cables are loose. Poor contact may result in poor starting or malfunctions. Always keep the terminals firmly tightened. Coating the terminals with a thin film of grease will help to inhibit corrosion.

Battery Cable Installation

ALWAYS be sure the battery cables (Figure 35) are properly connected to the battery terminals as shown below. The **RED** cable is connected to the positive terminal of the battery, and the **BLACK** cable is connected to the negative terminal of the battery.

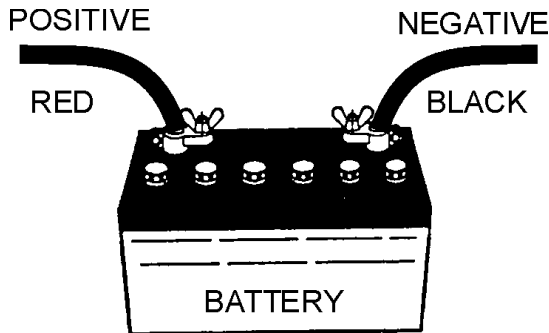

Figure 35. Battery Connections

Alternator

The polarity of the alternator is negative grounding type. When an inverted circuit connection takes place, the circuit will be in short circuit instantaneously resulting the alternator failure.

Do not put water directly on the alternator. Entry of water into the alternator leads an electrolyte corrosion causing an alternator failure.

Before charging the battery with an external electric source, be sure to disconnect the battery cables.

CAUTION :



If the battery cable is connected incorrectly, damage to the generator will occur. Pay close attention to the polarity of the battery when connecting the battery.

When connecting battery do the following:

1. **DO NOT** connect the battery cables to the battery terminals when the key is in the ignition and is set in 'START' mode. **ALWAYS** remove the key from the ignition and the ignition switch is in the OFF position when connecting the battery.
2. Place a small amount of grease around both battery terminals. This will ensure a good connection and will help prevent corrosion around the battery terminals.

CAUTION :

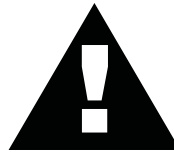

Inadequate battery connections may cause poor starting of the generator, and create other malfunctions.

Wiring

Inspect the entire generator for bad or worn electrical wiring or connections. If any wiring or connections are exposed (insulation missing) replace wiring immediately.

Piping and Hose Connection

Inspect all piping, oil hose, and fuel hose connections for wear and tightness. Tighten all hose clamps and check hoses for leaks.

If any hose (fuel or oil) lines are defective replace them immediately.

Single Phase Load

Always be sure to check the nameplate on the generator and equipment to insure the wattage, amperage and frequency requirements are satisfactorily supplied by the generator for operating the equipment.

Generally, the wattage listed on the nameplate of the equipment is its rated output. Equipment may require 130—150% more wattage than the rating on the nameplate, as the wattage is influenced by the efficiency, power factor and starting system of the equipment.

When the voltage selector switch is in single phase (240/120V position), place the AC voltmeter change-over switch to the U-W position and the AC ammeter change over-switch to the U or W position to read the output.

NOTE

If wattage is not given on the equipment's name plate, approximate wattage may be determined by multiplying nameplate voltage by the nameplate amperage.

$$\text{WATTS} = \text{VOLTAGE} \times \text{AMPERAGE}$$

The power factor of this generator is 1.0. See Table 14. below when connecting loads.

Table 14. Power Factor By Load

Type Of Load	Power Factor
Single-phase induction motors	0.4 - 0.75
Electric heaters, incandescent lamps	1.0
Fluorescent lamps, mercury lamps	0.4 - 0.9
Electronic devices, communication equipment	1.0
Common power tools	0.8

Three Phase Load

When calculating the power requirements for 3-phase power use the following equation:

$$\text{KVA} = \frac{\text{VOLTAGE} \times \text{AMPERAGE} \times 1.732}{1000}$$

CAUTION:



Motors and motor-driven equipment draw much greater current for starting than during operation.

An inadequate size connecting cable which cannot carry the required load can cause a voltage drop which can burn out the appliance or tool and overheat the cable.

- When connecting a resistance load such as an incandescent lamp or electric heater, a capacity of up to the generating set's rated output (kW) can be used.
- When connecting a fluorescent or mercury lamp, a capacity of up to the generating set's rated output (kW) multiplied by 0.6 can be used.
- When connecting an electric drill or other power tools, pay close attention to the required starting current capacity.

If wattage is not available on the equipment, approximate wattage may be determined by multiplying the nameplate voltage by the nameplate amperage for three-phase:
 $\text{WATTS} = 1.732 \times \text{VOLTAGE} \times \text{AMPERAGE}$

CAUTION:



Before connecting this generator to any building's electrical system, a licensed electrician must install an isolation (transfer) switch. Serious injury or death may result without this transfer switch.

NOTE

If output (kVA) is not given on the equipment nameplate, approximate output may be determined by multiplying voltage by amperage by $\sqrt{3}$

WARNING:



The engine's exhaust contains harmful emissions. **ALWAYS** ventilate the exhaust when operating inside tunnels, excavations or buildings. Direct exhaust away from nearby personnel.

Before Starting Engine

1. Check the lubricating oil level prior to starting the engine. Make sure the generator is level. The oil level must be maintained between two notches on the dipstick.
2. When there is not enough lubricating oil, fill the crankcase with high grade motor oil. Use a high quality detergent oil classified CC or higher (See Table 11 on page 43).
3. Check the coolant level in the radiator and subtank. Replenish with antifreeze as necessary. Always maintain the coolant level between the **FULL** and **LOW** markings on the coolant container. Be sure that the radiator cap is fastened securely.
4. Check the fuel level on the fuel gauge. If fuel is low, fill the fuel tank with clean fresh unleaded automotive diesel. If diesel spillage occurs, completely wipe up the spilled fuel immediately.

Before Starting Generator and Control Panel

CAUTION:



NEVER start the engine with the **main, GFCI** or **load** circuit breakers in the **ON** position.

1. Be sure to disconnect the electrical load and switch the **main, load** and **G.F.C.I.** circuit breakers (Figure 12) to the "OFF" position prior to starting the engine.

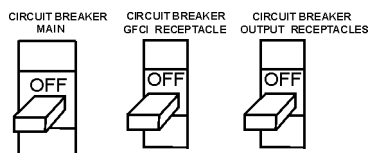

Figure 36. Main, GFCI and Load Circuit Breakers

2. Connect the load to the UVW terminals as shown in Figure 37. These terminals can be found on the output terminal panel, (see page 22 Figure 6). To gain access to the output terminals lift the UVW cover. Tighten terminal nuts securely to prevent load wires from slipping out.

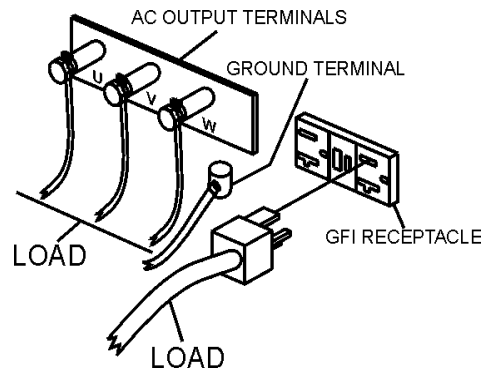

Figure 37. UVW Terminal Lugs (Load)

3. Connect the negative battery cable (BLACK) to the negative post on the battery (Figure 38).

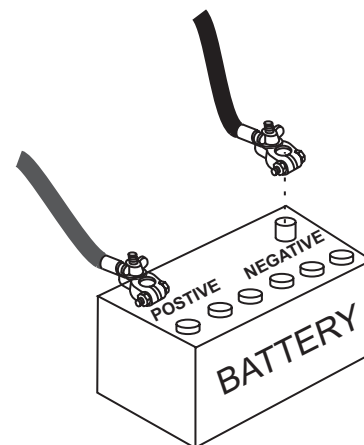
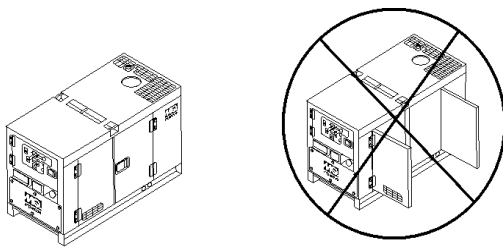

Figure 38. Battery Connections

DCA-60SSAI — GENERATOR START-UP PROCEDURE

4. Close all engine enclosure doors (Figure 39).



CORRECT

INCORRECT

Figure 39. Engine Enclosure Doors

5. Check the voltage selection switch (Figure 40) is at the desired voltage.

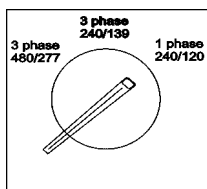

Figure 40. Voltage Selection Switch

6. Check to see if the engine throttle lever (Figure 41) is pushed in.

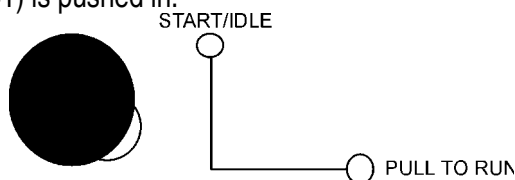

Figure 41. Engine Throttle Lever

7. Turn the starter switch to 'PREHEAT' (Figure 42) until the indicator light turns on. The oil pressure indicator light will initially turn on, but should turn off once the pressure rises.

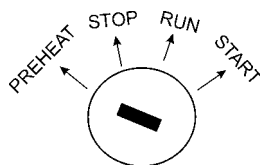

Figure 42. Key Switch (Preheat)

8. Once the preheat indicator lights, turn the key to 'START' (Figure 43). After the engine cranks, release the key to 'RUN'.

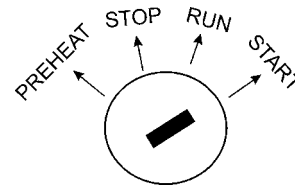

Figure 43. Starter Switch (Start)

9. Pull the engine throttle lever and turn left until the lever sets on the knob (Figure 44).

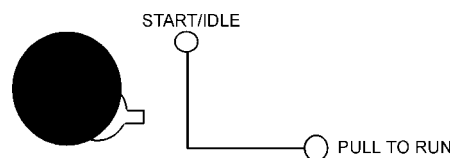

Figure 44. Engine Throttle Lever (Up)

10. The generator's frequency meter (Figure 45) displays the 60 cycle output frequency in **HERTZ**.

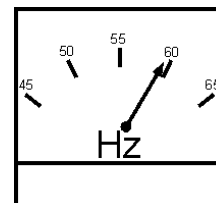

Figure 45. Frequency Meter (Hz)

11. The generator's voltage meter (Figure 46) displays the 120 VAC in **VOLTS**. If the voltage is not within the specified frequency tolerance, use the voltage adjustment control knob (Figure 47) to increase or decrease the desired voltage.

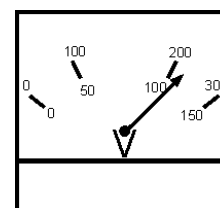

Figure 46. Voltage Meter (Volts)

DCA-60SSAI — GENERATOR START-UP PROCEDURE

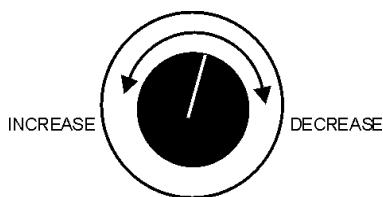

Figure 47. Voltage Adjust Control Knob

12. The ammeter (Figure 48) will indicate zero amps with no load applied. When a load is applied, this meter will indicate the amount of current that the load is drawing from the generator's alternator.

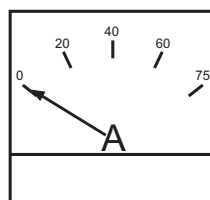

Figure 48. Ammeter (No Load)

13. The engine oil pressure gauge (Figure 49) will indicate the oil pressure (kg/cm²) of the engine. Under normal operating conditions the oil pressure is approximately 25 psi.

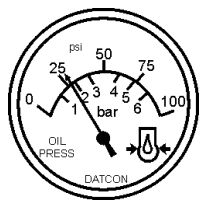

Figure 49. Oil Pressure Gauge

14. The coolant temperature gauge (Figure 50) will indicate the coolant temperature. Under normal operating conditions the coolant temperature is between 165 and 215 degrees fahrenheit.

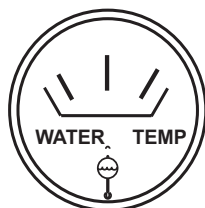

Figure 50. Coolant Temperature Gauge

15. The charging ammeter (Figure 51) will indicate if the battery is properly charged.



Figure 51. Charging Ammeter

16. The tachometer (Figure 52) will indicate the speed of the engine when the generator is operating. Under normal operating conditions this speed is approximately 1800 RPM's.

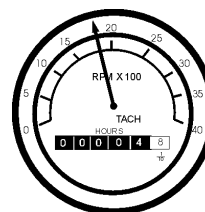

Figure 52. Engine Tachometer

17. Turn the MAIN, GFCI and LOAD circuit breakers to their ON position (Figure 53).

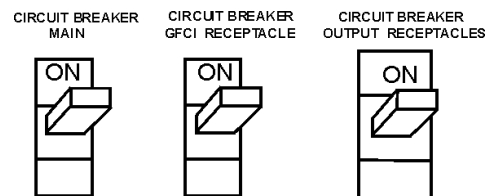

Figure 53. Main and GFCI Circuit Breakers

18. Observe the generator's ammeter (Figure 54) and verify it reads the anticipated amount of current with respect to the load. The ammeter will only display a current reading if the load is in use.

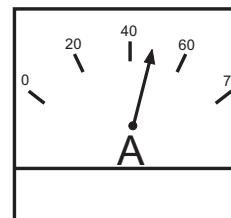

Figure 54. Ammeter (Load)

19. The generator will run until manually stopped or an abnormal condition occurs.

DCA-60SSAI — GENERATOR SHUT-DOWN PROCEDURE

ENGINE SHUTDOWN

To shutdown the generator, use the following procedure:

1. Switch both the MAIN, GFCI and LOAD circuit breakers (Figure 55) to the "OFF" position.

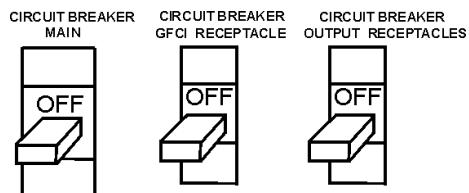

Figure 55. Main, GFCI and Load circuit breakers

2. Turn to the right and press in the engine throttle lever (Figure 56).

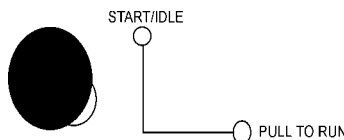

Figure 56. Engine Throttle Lever

3. Let the engine cool by running it for 3-5 minutes with no load applied.
4. Turn the key switch to "STOP" (Figure 57).

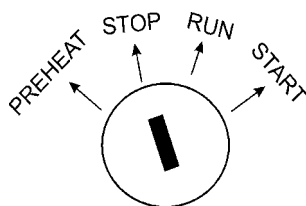

Figure 57. Key Switch (OFF)

5. Remove the load from the UVW terminal strip.

EMERGENCY STOP

1. To stop the engine in the event of an emergency, switch the MAIN, GFCI and LOAD circuit breakers to 'OFF' position.
2. Turn the key switch to 'STOP'.

General Inspection

Prior to each use, the generator should be cleaned and inspected for deficiencies. Check for loose, missing or damaged nuts, bolts or other fasteners. Also check for fuel, oil, and coolant leaks.

Engine Side (Refer to the Engine Instruction Manual)

Air Cleaner

Every 50 hours: Remove air cleaner element and clean heavy duty paper element with kerosene, or foam element with liquid detergent and hot water. Wrap foam element in a cloth and squeeze dry. For heavy duty paper element, wipe excess kerosene with towel.

The air cleaner is equipped with an indicator. After the dirty air cleaner has been replaced, press the dust indicator button to reset the indicator.

Fuel Addition

Add diesel fuel (the grade may vary according to season and locations). Always pour through the mesh filter.

Removing Water from the Fuel Tank

After prolonged use, water and other impurities accumulate in the bottom of the tank. Occasionally remove the drain cock and drain the contents. During cold weather, the more empty volume inside the tank, the easier it is for water to condense. This can be reduced by keeping the tank full as much as possible.

Air Removal

If air enters the fuel injection system of a diesel engine, starting becomes impossible. After running out of fuel, or after disassembling the fuel system, bleed the system according to the following procedure.

To restart after running out of fuel, turn the switch to the "ON" position for 15-30 seconds. Try again, if needed. This unit is equipped with an automatic air bleeding system.

Service Daily

If the engine is operating in very dusty or dry grass conditions, a clogged air cleaner will result. This can lead to a loss of power, excessive carbon buildup in the combustion chamber in high fuel consumption.

Cleaning the Fuel Strainer

Clean the fuel strainer if it contains dust or water. Remove dust or water in the strainer cap and wash it in gasoline. Securely fasten the fuel strainer cap so that fuel will not leak. Check the fuel strainer every 200 hours of operation or once a month.

Check Oil Level

Check the crankcase oil level prior to each use, or when the fuel tank is filled. Insufficient oil may cause severe damage to the engine. Make sure the generator is level. The oil level must be between the two notches on the dipstick as shown in Figure 32, page 43.

Replacing Oil Filter

1. Detach the oil filter cartridge with a filter wrench.
2. Apply a film of oil to the gasket for the cartridge.
3. Screw in the cartridge by hand. When the gasket is in contact with the seal surface, tighten the cartridge one or two more times by hand.
4. After the oil cartridge has been replaced, the engine oil will drop slightly. Run the engine for a while and check for leaks before adding more oil if needed. Clean excessive oil from engine.

Replacing Fuel Filter

1. Replace the fuel filter cartridge with new one every 400 hours or so.
2. Apply fuel oil thinly over the gasket and hand-tighten the cartridge into position.
3. Vent any air.
4. **Fuel Injection Nozzle**
5. Use an injection nozzle tester to check the static injection starting pressure and the fuel spray conditions.
6. Abnormal fuel consumption will lead to a lowered output and blackish exhaust smoke. The required injection starting pressure should be 14.7MPa (150kg/cm², 2130psi).

Feed Pump Strainer Cleaning

The strainer is incorporated in the feed pump inlet side joint bolt. Clean the strainer with compressed air and rinse it in the fuel oil.

Flushing Out Radiator and Replacing Coolant

1. Open both cocks located at the crankcase side and at the lower part of the radiator and drain coolant. Open the radiator cap while draining. Remove the overflow tank and drain.
2. Check hoses for softening and kinks. Check clamps for signs of leakage.
3. Flush the radiator by running clean tap water through radiator until signs of rust and dirt are removed. **DO NOT** clean radiator core with any objects, such as a screwdriver.
4. Tighten both cocks and replace the overflow tank.
5. Replace with coolant (see page 44, Table 14 for mixture).
6. Close radiator cap tightly.

CAUTION :



Allow engine to cool when flushing out radiator. Flushing the radiator while hot will damage radiator.

Valve Clearance Check

1. In order to bring No. 1 or No. 4 cylinder to top dead center in the compression stroke, align the notched line on the crank pulley with TDC mark on the timing gear case cover.
2. Do the adjustment on the circle marked valves in the below table where No. 1 cylinder is at the center in the compression stroke.
3. After adjustment started from either piston top center, turn the crankshaft 360° to align the notched line with the TDC mark to do the adjustment again on the remaining valve. See Table 16 and Figure 55 for valve arrangement.

Injection Timing Check and Adjustment

1. Bring No. cylinder to the top dead center on the compression stroke.
2. Turn the crankshaft pulley clockwise (viewed at engine front) and align the notched line on the crank pulley with the TDC mark on the timing gear case cover.

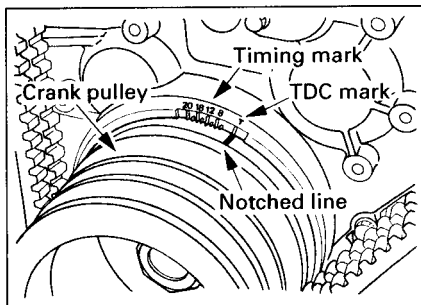

Figure 58. Valve Adjustment

NOTE:

Take necessary precautions to prevent dust and foreign particles in the pump interior when timing adjustments are made.

3. Remove the timing check hole cover at the front of injection pump to check the alignment between the pointer "a" on the injection pump gear lock plate and the projected area mark "b" on the timing gear case.
4. If "a" and "b" are in alignment, the timing is set correctly. If not, follow nos. 1-3 until the "a" and "b" are aligned.
5. Reversely turn the crankshaft pulley counterclockwise viewed at the engine front about 30° crank angle.
6. Remove No. 1 injection pipe from the engine.
7. Remove the injection pump No. 1 delivery valve holder, delivery valve and spring and reinstall the delivery valve holder on the original place.
8. Delivery valve holder tightening torque: 39~44Nm(29~33lbf.)
9. Slowly turn the crankshaft pulley clockwise and at the same time continue to feed the fuel with pumping the Feed pump. When the fuel stop to flow out from No. 1 delivery valve holder, stop pumping.
10. Observe and make sure which mark (injection starting angle line) on the timing gear case cover is aligning with the notched line on the crank pulley.
11. The timing line shows the injection starting crank angle of the engine.
12. The injection starting crank angle should be at the 14° timing mark.

**Table 15. Valve Adustment
(I=Inlet; E=Exhaust)**

Cylinder No.	1		2		3		4	
Valve Arrangement	I	E	I	E	I	E	I	E
When No. 1 is at top dead center in the compression stoke	X	X	X			X		
When No. 4 is at top dead center in the compression stroke				O	O		O	O

INSPECTION / MAINTENANCE		10 Hrs DAILY	250 Hrs	500 Hrs	1000 Hrs
ENGINE	Check Engine Fluid Levels	X			
	Check Air Cleaner	X			
	Check Battery Acid Level	X			
	Check Fan Belt Condition	X			
	Check for Leaks	X			
	Check for Loosening of Parts	X			
	Replace Engine Oil and Filter *1		X		
	Clean Air Filter		X		
	Drain Bottom of Fuel Tank		X		
	Clean Unit, Inside and Outside		X		
	Change Fuel Filter *2			X	
	Clean Radiator and Check Coolant Protection Level			X	
	Replace Air Filter Element				X
	Change Corrosion Resistor				X
	Check all Hoses and Clamps				X
Clean Inside of Fuel Tank				X	
GENERATOR	Measure Insulation Resistance Over 3M ohms		X		

*1 Replace engine oil and filter at 100 hours, first time only.

*2 Replace fuel filter at 250 Hours, first time only.

Generator Storage

For storage of the generator for over 30 days, the following is required:

- Fill the fuel tank completely.
- Completely drain the oil from the crankcase and refill with fresh oil.
- Clean all external parts of the generator with a cloth.
- Cover the generating set and store in a clean, dry place.

DCA-60SSAI — ENGINE WIRING DIAGRAM

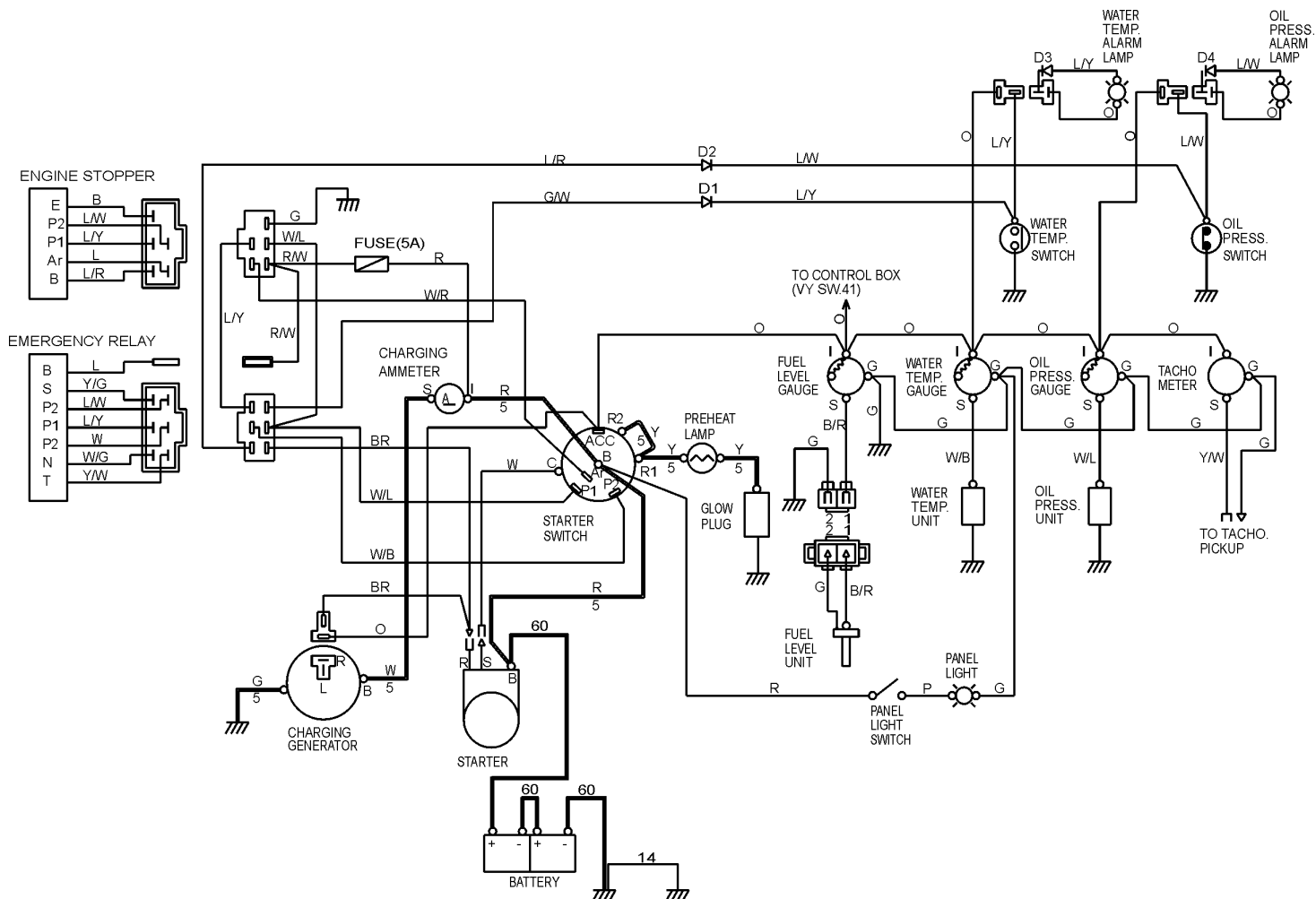

COLOR CODE TABLE

CODE/ WIRE COLOR			
B	BLACK	R	RED
L	BLUE	W	WHITE
BR	BROWN	Y	YELLOW
G	GREEN	LB	LIGHT BLUE
GR	GRAY	LG	LIGHT GREEN
V	VIOLET	O	ORAGNE
P	PINK		

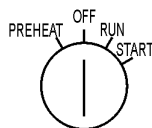

KEY CONNECTION DIAGRAM

	B	R-1	ACC	R-2	C	Ar	P-1	P-2
OFF	●					●	●	
PREHEAT	●	●				●	●	
RUN	●		●			●	●	●
START	●			●	●	●	●	●

DCA-60SSAI — TROUBLESHOOTING (ENGINE)

Practically all breakdowns can be prevented by proper handling and maintenance inspections, but in the event of a breakdown, use the tables shown for

diagnosis based on the Engine Troubleshooting (Table 16). If the problem cannot be remedied, consult our company's business office or service plant.

TABLE 16. ENGINE TROUBLESHOOTING

SYMPTOM	POSSIBLE PROBLEM	SOLUTION
Engine does not start.	No fuel?	Replenish fuel.
	Air in the fuel system?	Bleed system.
	Water in the fuel system?	Remove water from fuel tank.
	Fuel pipe clogged?	Clean fuel pipe.
	Fuel filter clogged?	Clean or change fuel filter.
	Excessively high viscosity of fuel or engine oil at low temperature?	Use the specified fuel or engine oil.
	Fuel with low cetane number?	Use the specified fuel.
	Fuel leak due to loose injection pipe retaining nut?	Tighten nut.
	Incorrect injection timing?	Adjust.
	Fuel cam shaft worn?	Replace.
	Injection nozzle clogged?	Clean injection nozzle.
	Injection pump malfunctioning?	Repair or replace.
	Seizure of crankshaft, camshaft, piston, cylinder liner or bearing?	Repair or replace.
	Compression leak from cylinder?	Replace head gasket, tighten cylinder head bolt, glow plug and nozzle holder.
	Improper valve timing?	Correct or replace timing gear.
	Piston ring and liner worn?	Replace.
Excessive valve clearance?	Adjust.	
Starter does not run.	Starter malfunctioning?	Repair or replace.
	Wiring disconnected?	Connect wiring.

TABLE 16. ENGINE TROUBLESHOOTING (CONTINUED)

SYMPTOM	POSSIBLE PROBLEM	SOLUTION
Engine revolution is not smooth.	Fuel filter clogged or dirty?	Clean or change.
	Air cleaner clogged?	Clean or change.
	Fuel leak due to loose injection pipe retaining nut?	Tighten nut.
	Injection pump malfunctioning?	Repair or replace.
	Incorrect nozzle opening pressure?	Adjust.
	Injection nozzle stuck or clogged?	Repair or replace.
	Fuel over flow pipe clogged?	Clean.
	Governor malfunctioning?	Repair.
Either white or blue exhaust gas is observed.	Excessive engine oil?	Reduce to the specified level.
	Piston ring and liner worn or stuck?	Repair or replace.
	Incorrect injection timing?	Adjust.
	Deficient compression?	Adjust top clearance.
Either black or dark gray exhaust gas is observed.	Overload?	Lessen the load.
	Low grade fuel used?	Use the specified fuel.
	Fuel filter clogged?	Clean or change.
	Air cleaner clogged?	Clean or change.
	Deficient nozzle injection?	Repair or replace the nozzle.
Deficient output.	Incorrect injection timing?	Adjust.
	Engine's moving parts seem to be seizing?	Repair or replace.
	Uneven fuel injection?	Repair or replace the injection pump.
	Deficient nozzle injection?	Repair or replace the nozzle.
	Compression leak?	Replace head gasket, tighten cylinder head bolt, glow plug and nozzle holder.

DCA-60SSAI — TROUBLESHOOTING (GENERATOR/ENGINE)

Practically all breakdowns can be prevented by proper handling and maintenance inspections, but in the event of a breakdown, use the tables shown for diagnosis based on the Engine and Radiator Troubleshooting (Table 7). If the problem cannot be remedied, consult our company's business office or service plant.

TABLE 17. ENGINE & GENERATOR TROUBLESHOOTING

SYMPTOM	POSSIBLE PROBLEM	SOLUTION
Engine fails to start and starter does not rotate.	Dead battery?	Replace battery.
	Defective starter switch?	Replace switch.
	Fuse F5 burned out?	Replace fuse.
Engine fails to start and starter rotates.	Broken pre-heat circuit?	Check pre-heat circuit.
	No fuel?	Add fuel.
	Defective wiring?	Check wiring.
Engine starts and remains at low speed.	Clogged fuel strainer?	Clean or replace.
	Clogged air cleaner?	Clean or replace.
	Disconnected wiring?	Check and repair wiring.
Engine speed rises and no voltage is present in AC power source.	No voltage present in AC power source?	Replace rectifier (RE1).
	Defective rotor?	Replace rotor.
	Defective voltmeter?	Replace voltmeter.
	Disconnected wiring?	Check and repair wiring.
	Layer short-circuit in armature winding?	Replace armature.
Engine speed rises and AC power voltage is too low or cannot be used.	Defective circuit breaker (protector)?	Replace circuit breaker (protector).
	Layer short-circuit, broken wires in armature winding?	Repair or replace armature.
Engine speed rises and battery discharges too soon.	Defective engine regulator?	Replace regulator.
	Defective wiring?	Repair or replace wiring.
Engine speed rises and engine seems overloaded.	Defective alternator?	Repair or replace alternator.
	Damaged alternator bearing?	Replace alternator bearings.

EXPLANATION OF CODE IN REMARKS COLUMN

How to read the marks and remarks used in this parts book.

Items Found In the “Remarks” Column

Serial Numbers-Where indicated, this indicates a serial number range (inclusive) where a particular part is used.

Model Number-Where indicated, this shows that the corresponding part is utilized only with this specific model number or model number variant.

Items Found In the “Items Number” Column

All parts with same symbol in the number column, *, #, +, or %, belong to the same assembly or kit.

Note: If more than one of the same reference number is listed, the last one listed indicates newest (or latest) part available.

DCA-60SSAI W/ISUZU 6BD1 DIESEL ENGINE 1 TO 3 UNITS

<u>Qty.</u>	<u>P/N</u>	<u>Description</u>
1	0601805869	CIRCUIT BREAKER
1	0601820671	AUTOMATIC VOLTAGE REGULATOR
1	0601840073	RHEOSTAT VOLTAGE REGULATOR
1	0601840121	KNOB REHOSTAT
1	0602013901	RADIATOR HOSE, UPPER
1	0602013160	RADIATOR HOSE, LOWER
5	1878100753	OIL FILTER
5	X132400240	FUEL FILTER
5	0602040193	ELEMENT, AIR
1	0602122200	UNIT OIL PRESSURE
1	0602123204	UNIT WATER PRESSURE
1	0601810244	BULB, ALARM LAMP
1	0601808507	TRANSDUCER WATT METER
1	8972322520	FAN BELT
1	1823100080	STARTER SWITCH
3	KEYISUZUF	KEY, STARTER SWITCH

NOTE

Part number on this Suggested Spare Parts list may supercede/replace the P/N shown in the text pages of this book.

DCA-60SSAI --- GENERATOR ASSY.

GENERATOR ASSY.

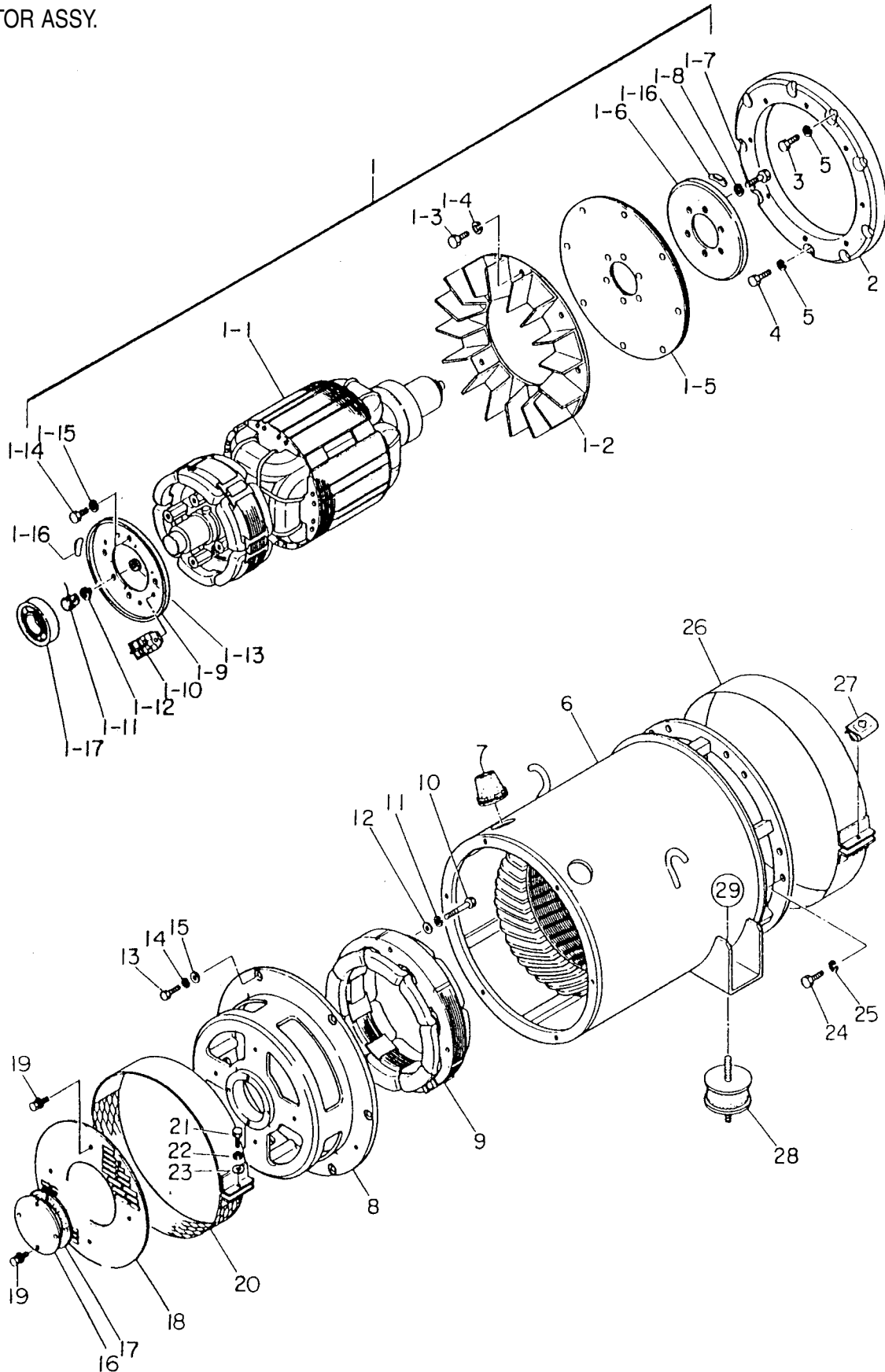

DCA-60SSAI --- GENERATOR ASSY.

GENERATOR ASSY.

<u>NO.</u>	<u>PART NO.</u>	<u>ITEM</u>	<u>QTY.</u>	<u>REMARKS</u>
1	7451040000	FIELD ASSY.	1	
1-1	3361010112	SHAFT	1	
1-2	7461042003	FIELD CORE	1	
1-3	3361080003	FIELD COIL	1	
1-4	3361032003	ARMATURE CORE, EXCITER	1	
1-5	3361085003	ARMATURE COIL, EXCITER	1	
1-6	3341610003	COUPLING HUB	1	
2	3361025003	RECTIFIER ASSY.	1	
2-1	3361026003	SET PLATE, RECTIFIER	1	
2-2	0601820067	RECTIFIER	3 PB2510
2-3	0010004020	HEX. HEAD BOLT	3	
2-4	0041604000	PLAIN WASHER	6	
2-5	0040004000	LOCK WASHER	3	
2-6	0030004000	HEX. NUT	3	
2-7	0601822601	SURGE ABSORBER	1 ERZM14JK621A
2-8	0801841004	INSULATOR WASHER	1	
2-9	0801841104	INSULATOR WASHER	1	
2-10	0010005020	HEX. HEAD BOLT	1	
2-11	0041605000	PLAIN WASHER	2	
2-12	0040005000	LOCK WASHER	1	
2-13	0030005000	HE. NUT	1	
2-14	0017105012	HE.HEAD BOLT	4	
3	3331014004	BEARING FLANGE	1	
4	0070206310	BEARING	1 6310RS
5	008000050	SNAP RING	1	
6	3361070003	FAB	1	
7	3341611003	COUPLING DISC	1 (80 0
8	3341613004	LOCK WASHER	5	
10	0010312030	HEX. HEAD BOLT	10	
11	060160000	COUPLING RING	1 92612590050
12	0601610700	LOCK WASHER	9 9091505100
13	0601610511	BOLT SET	1	
14	0040010000	LOCK WASHER	9	
15	0010310030	HEX. HEAD BOLT	9	
16	7451340000	STATOR ASSY.	1	
16-1	3361320122	GENERATOR FRAME	1	
16-2	3361342024	ARMATURE CORE	1	
16-3	7451361113	ARMATURE COIL	1	
17	0801350104	GROMMET	1	
18	3361315013	END BRACKET	1	

GENERATOR ASSY.

GENERATOR ASSY.

<u>NO.</u>	<u>PART NO.</u>	<u>ITEM</u>	<u>QTY.</u>	<u>REMARKS</u>
19	3361350030	FIELD ASSY., EXCITER	1	
19-1	3361352023	FIELD CORE, EXCITER	1	
19-2	3361362303	FIELD COIL, EXCITER	1	
20	0041608000	PLAIN WASHER	4	
21	0040008000	LOCK WASHER	4	
22	0010008060	HEX. HEAD BOLT	4	
23	0040010000	LOCK WASHER	6	
24	0010010030	HEX. HEAD BOLT	6	
25	3801312004	GASKET, BERAING	1	
26	3331310104	COVER, BEARING	1	
27	0040006000	LOCK WASHER	4	
28	0010006055	HEX. HEAD BOLT	4	
29	3361331003	COVER, END BRACKET	1	
30	0017106010	HEX. HEAD BOLT	8	
31	0040010000	LOCK WASHER	6	
32	0010310025	HEX. HEAD BOLT	6	
33	3341332103	COVER, FAN	1	
34	0041606000	PLAIN WASHER	1	
35	0040006000	LOCK WASHER	1	
36	0010006030	HEX. HEAD BOLT	1	
37	0605000011	RUBBER SUSPENSION	2	
38	0040016000	LOCK WASHER	4	
39	0030116000	HEX. NUT	4	

DCA-60SSAI --- CONTROL BOX ASSY.

CONTROL BOX ASSY.

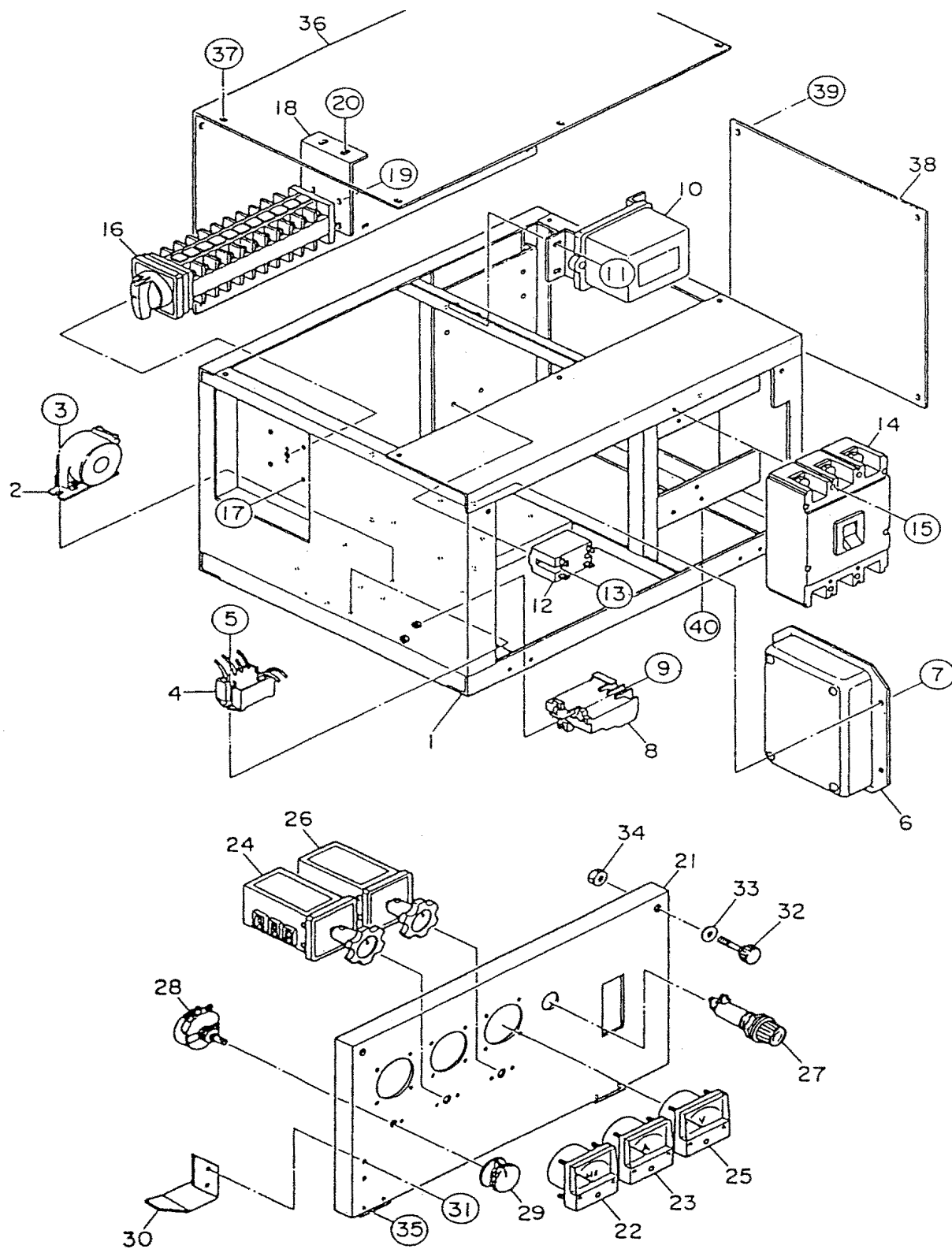

DCA-60SSAI --- CONTROL BOX ASSY.

CONTROL BOX ASSY.

<u>NO.</u>	<u>PART NO.</u>	<u>ITEM</u>	<u>QTY.</u>	<u>REMARKS</u>
1	7451810002	CONTROL BOX	1 UP TO S/N3311616
	7451810012	CONTROL BOX	1 S/N3311617 TO 3312672
	7451810022	CONTROL BOX	1 S/N3312673~
2	3361870603	CURRENT TRANSFORMER	3	
3	0017106016	HEX. HEAD BOLT	6	
4	0601801143	CURRENT TRANSFORMER, AMMETER	2 CT3.5MR 100/5A
5	0027104010	MACHINE SCREW	4	
6	0800225201	AUTOMATIC VOLTAGE REGULATOR	1 AE2206A
7	0027106010	MACHINE SCREW	6	
8	0601820042	RECTIFIER	1 16T60
9	0027103010	MACHINE SCREW	4	
10	0601842058	RESISTOR	1 RWH80V 200KOHMS
11	0027105010	MACHINE SCREW	2	
12	0601820851	OVER CURRENT RELAY	1 THK20
13	0027104016	MACHINE SCREW	2	
14	0601805352	CIRCUIT BREAKER	1 KM203 550V 150AT
15	0041604000	PLAIN WASHER	4	
16	0040004000	LOCK WASHER	4	
17	0021004020	MACHINE SCREW	4	
18	0601830625	CHANGE-OVER SW. VOLTAGE	1	
	0601840191	SWITCH CAP	1	
	0601830614	PLATE	1	
19	0021104016	MACHINE SCREW	4	
20	0021104014	MACHINE SCREW	2	
21	7451822503	CONTROL PANEL	1	
22	0601800460	FREQUENCY METER	1 PAK60 220V 45~65Hz
23	0601800784	AC AMMETER	1 PSK60 0~100A 0~200a
24	0601801040	CHANGE-OVER SW., AMMETER	1 SL2AS
25	0601800217	AC VOLTMETER	1 PCK60 0~600V
26	0601801041	CHANGE OVER SW., VOLTMETER	1 SL2VS
27	0601810072	PILOT LAMP	1	
	0601810261	BULB	1	

CONTROL BOX ASSY.

DCA-60SSAI --- CONTROL BOX ASSY.

CONTROL BOX ASSY.

<u>NO.</u>	<u>PART NO.</u>	<u>ITEM</u>	<u>QTY.</u>	<u>REMARKS</u>
28	0601840031	VOLTAGE REGULATOR	1 RA30A2FE202BJ
29	0601840120	KNOB	1	
30	3331824003	STOPPER, CONTROL PANEL	1	
31	0027105016	MACHINE SCREW	2	
32	0030005000	HEX. NUT	2	
33	0805001304	SET SCREW, CONTROL PANEL	2	
34	0041608000	PLAIN WASHER	2	
35	0030008000	HEX. NUT	2	
36	0027105010	MACHINE SCREW	4	
37	7451826504	SIDE PANEL, CONTROL BOX	1 UP TO S/N3311616
	7451826514	SIDE PANEL, CONTROL BOX	1 S/N3312178~
38	0017106016	HEX. HEAD BOLT	2	
39	0017108020	HEX. HEAD BOLT	4	
40	0030008000	HEX., NUT	4	
41	0601815933	TERMINAL	1 S/N3312673~; AYBS0431
42	0601815934	TERMINAL	1 S/N3312673~; AYBS0441
43	0027105020	MACHINE SCREW	4 S/N3312673~

DCA-60SSAI ENGINE AND RADIATOR ASSY.

ENGINE AND RADIATOR ASSY.

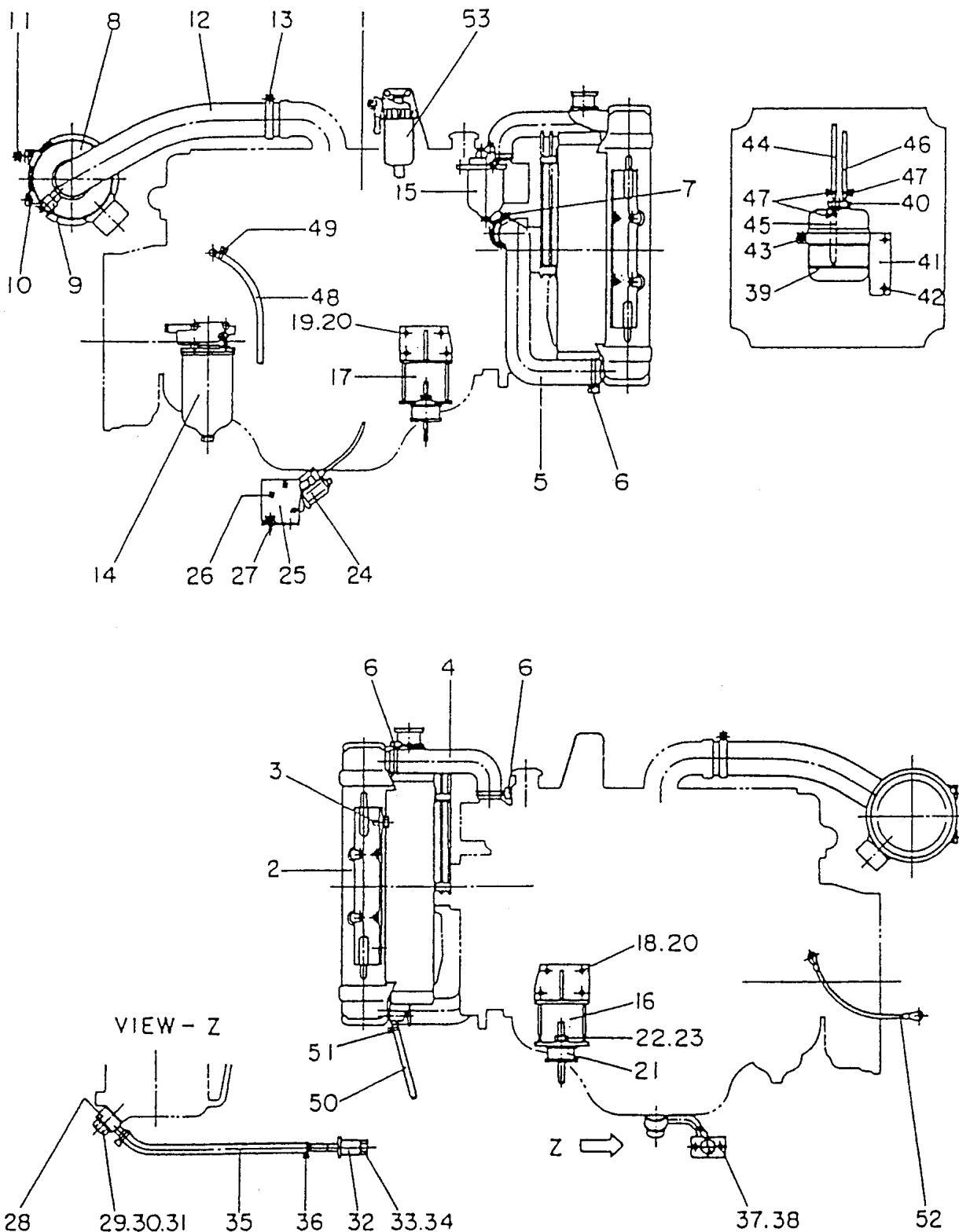

DCA-60SSAI ENGINE AND RADIATOR ASSY.

ENGINE AND RADIATOR ASSY.

<u>NO.</u>	<u>PART NO.</u>	<u>ITEM</u>	<u>QTY.</u>	<u>REMARKS</u>
1	0602000100	ENGINE	1	ISUZU 6BD1
2	0602010802	RADIATOR	1	H190110000
3	0602013901	RADIATOR HOSE	1	B400008
4	0602013160	RADIATOR HOSE	1	B400007
5	0602014302	HOSE BAND	3	
6	0602014303	HOSE BAND	1	
7	0602040090	AIR CLEANER	1	FWG088006
	0602040193	ELEMENT, AIR CLEANER	1	P104972
8	0602040690	DUST INDICATOR	1	RBX002252
9	0602040598	BAND, AIR CLEANER	2	AAH008263
10	0017108020	HEX. HEAD BOLT	4	
11	0030008000	HEX. NUT	4	
12	7452032303	HOSE, AIR CLEANER	1	
13	0605515008	HOSE BAND	2	
14	0602041106	ELEMENT, OIL FILTER	1	1878100750
15	0602042106	ELEMENT, FUEL FILTER	1	9885111911
16	3345112403	ENGIEN FOOT	1	
17	3345112503	ENGIEN FOOT	1	
18	0040010000	LOCK WASHER	8	
19	0010710025	HEX.HEAD BOLT	8	
20	0605000009	RUBBER SUSPENSION	2	
21	0040012000	LOCK WASHER	4	
22	0030112000	HEX. NUT	4	
23	0017108020	HEX. HEAD BOLT	6	
24	0602210803	ENGINE STOPPER	1	1819000161
25	7452215104	BRACKET, ENGINE STOPPER	1	
26	0027106016	MACHINE SCREW	3	
27	0017108020	HEX. HEAD BOLT	2	
28	7452051104	DRAIN JOINT	1	
29	0805013704	PACKING, OIL PAN SIDE	1	
30	0805014204	PACKING	1	

DCA-60SSAI ENGINE AND RADIATOR ASSY.

ENGINE AND RADIATOR ASSY.

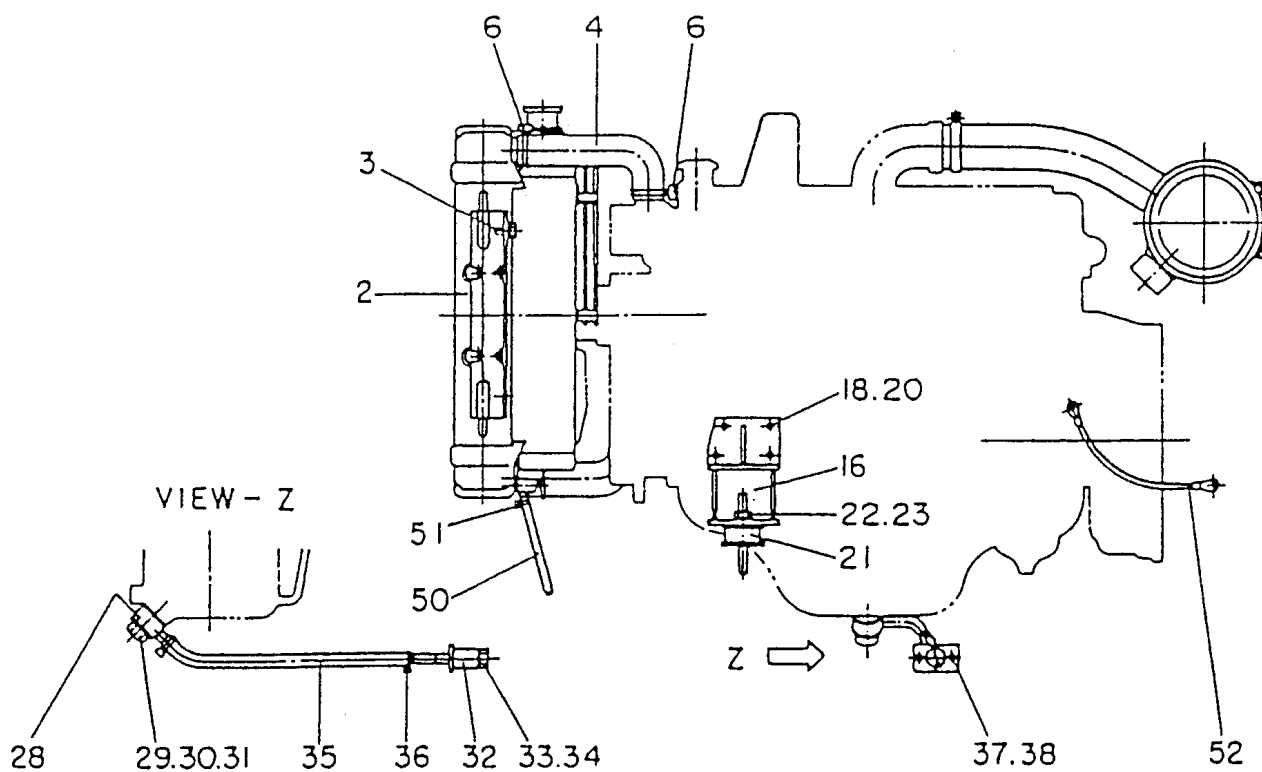
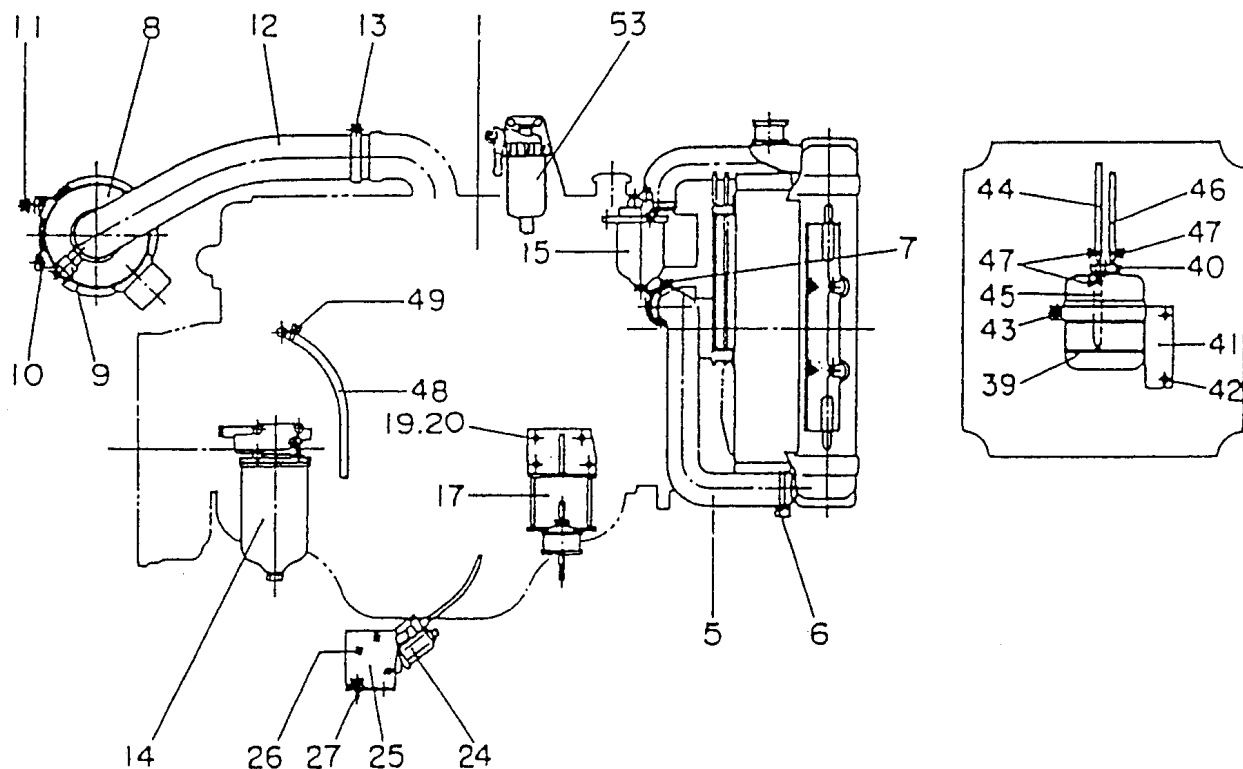

DCA-60SSAI ENGINE AND RADIATOR ASSY.

ENGINE AND RADIATOR ASSY.

<u>NO.</u>	<u>PART NO.</u>	<u>ITEM</u>	<u>QTY.</u>	<u>REMARKS</u>
31	3362054104	JOINT BOLT	1	
32	3362051003	DRIAN JOINT	1	
33	0802024004	PACKING	1	
34	0802010204	PLUG	1	
35	7452052104	DRAIN HOSE	1	
36	0605515003	HOSE BAND	2	
37	0017108020	HEX. HEAD BOLT	2	
38	0030008000	HEX. NUT	2	
39	0845031303	RESERVE TANK	1	
41	7452082504	BRAKET, RESERVE TANK	1	
42	0017108020	HE. HEAD BOLT	2	
43	0017106025	HEX. HEAD BOLT	1	
44	0199500470	HOSE	1	
45	0199500175	HOSE	1	
46	0193602000	HOSE	1	
47	0605515013	HOSE BAND	4	
48	0193100950	HOSE	1	
49	0605515007	HOSE BAND	1	
50	0193800850	HOSE	1	
51	0605515019	HOSE BAND	1	
52	7452220404	EARTH CABLE	1	

DCA-60SSAI --- ENGINE OPERATING PANEL ASSY.

ENGINE OPERATING PANEL ASSY.

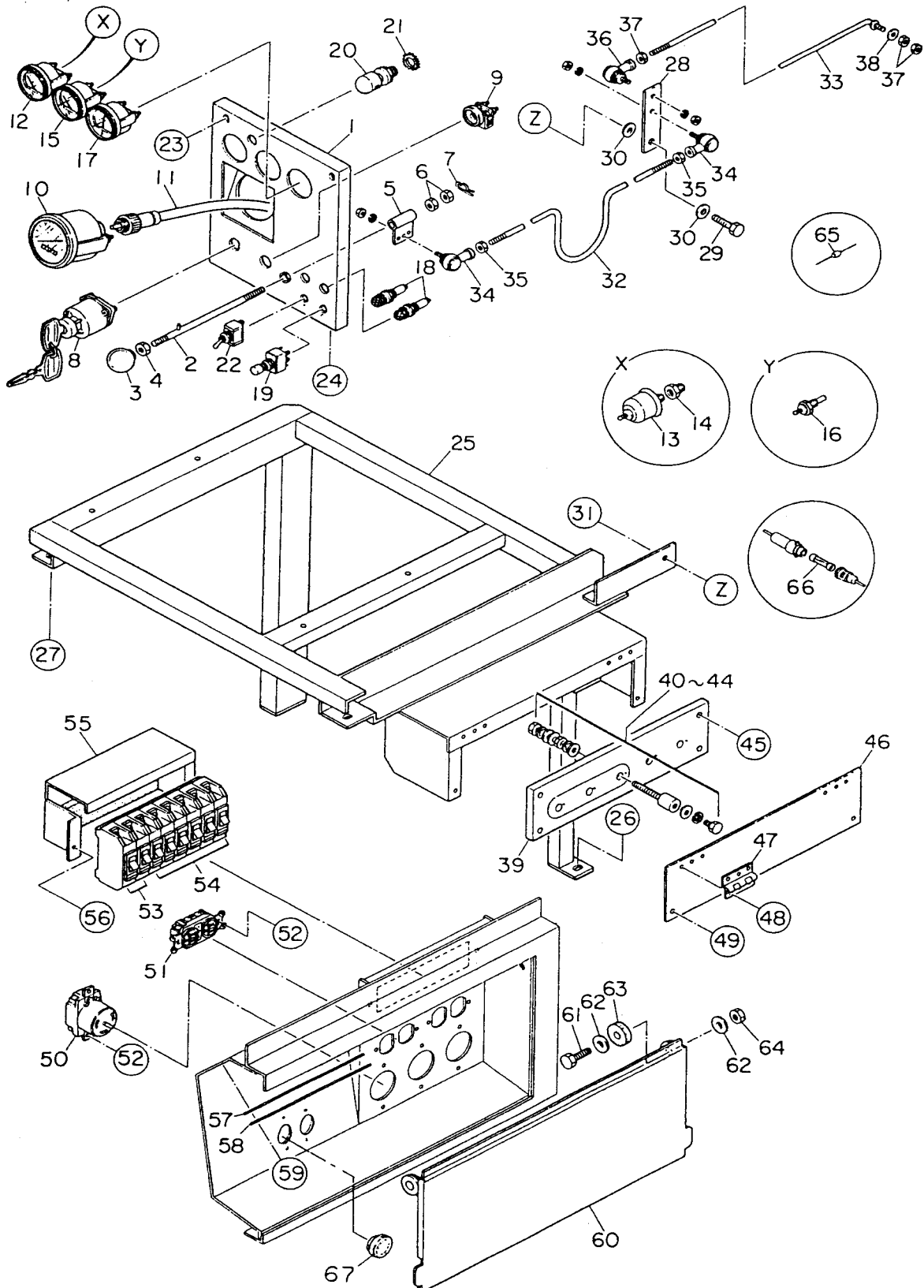

DCA-60SSAI --- ENGINE OPERATING PANEL ASSY.

ENGINE OPERATING PANEL ASSY.

<u>NO.</u>	<u>PART NO.</u>	<u>ITEM</u>	<u>QTY.</u>	<u>REMARKS</u>
1	7452111103	OPERATING PANEL	1	
2	7452142004	SLIDE BAR	1	UP TO S/N3313037
	7452142014	SLIDE BAR	1	S/N3313038~
3	0805012904	KNOB	1	
4	0080200006	SNAP RING	1	UP TO S/N3313037
	0036003000	HEX. NUT	1	S/N3313038~
5	7452140504	BRACKET, GOVERNOR ROD	1	
6	0030008000	HEX., NUT	2	
7	0605010503	SNAP PIN	1	
8	0602100004	STARTER SWITCH	1	1823100080
9	0602102005	PREHEAT LAMP	1	9825300430
10	0602120052	TACHOMETER	1	25000KX3710
11	0602120161	CABLE, TACHOMETER	1	62100KA0910 L=1700
12	0602122060	OIL PRESSURE GAUGE	1	42000KX1410
13	0602122200	UNIT, OIL PRESSURE	1	53000AC0101
14	0131300000	STREET SOCKET	1	
15	0602123061	WATER TEMPERATURE GAUGE	1	40000KX0910
16	0602123204	UNIT, WATER TEMPERATURE	1	51400KA1200
17	0602121052	CHARGING AMMETER	1	43000KV0300
18	0602103060	ALARM LAMP	2	
	0601810244	BULB	2	
19	0601830420	SWITCH, LAMP CHECK	1	SB61A
20	0601810120	PANEL LIGHT	1	DL31000
21	0040520000	TOITHED LOCKWASHER	1	
22	0601830710	SWITCH, PANEL LIGHT	1	
23	0041608000	PLAIN WASHER	2	
24	0040008000	LOCK WASHER	2	
25	0010008040	HEX. HEAD BOLT	2	
26	0017108020	HEX. HEAE BOLT	2	
30	0030008000	HEX. NUT	2	
31	7452183004	LINK, GOBERNOR ROD	1	
32	0010010025	HEX. HEAD BOLT	1	
33	0041610000	PLAIN WASHER2		
34	0030010000	HE.X NUT	1	
35	7452182004	GOVERNOR ROD	1	
36	7452152004	GOBERNOR ROD	1	
37	0602180101	BALL JOINT	2	
38	0030008000	HEX. NUT	2	
39	0602180100	BALL JOINT	2	
40	0030006000	HEX. NUT	3	
41	0041606000	PLAIN WASHER	1	
42	7455188103	SET PANEL, ELECTRIC PARTS	1	
43	0017108020	HEX. HEAD BOLT	5	
44	0602200405	EMERGENCY RELAY	1	1825500730
45	0027106016	MACHINE SCREW	4	
46	0601823706	RELAY	1	JH1A DC24V

DCA-60SSAI --- ENGINE OPERATING PANEL ASSY.

ENGINE OPERATING PANEL ASSY.

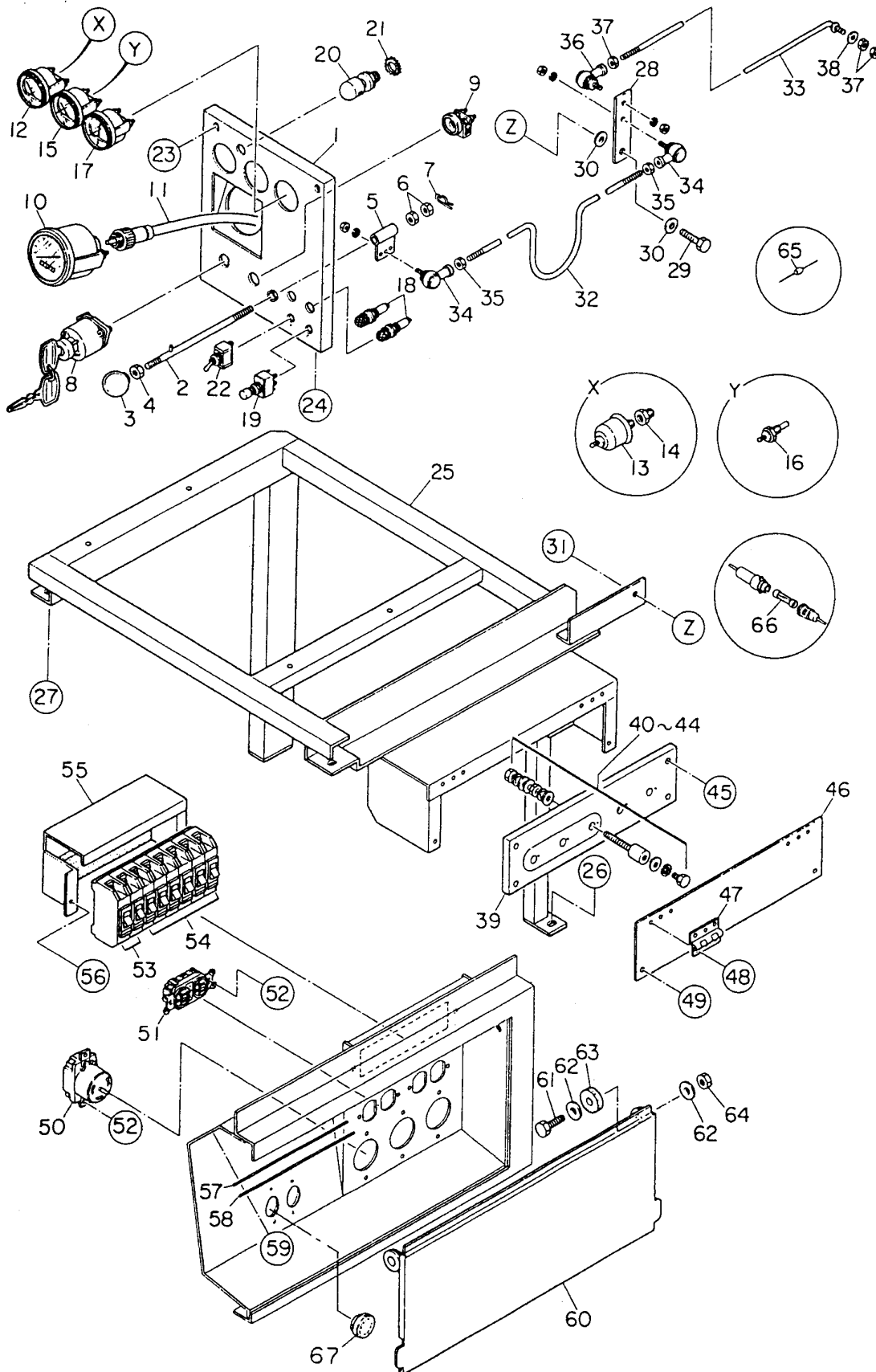

DCA-60SSAI --- ENGINE OPERATING PANEL ASSY.

ENGINE OPERATING PANEL ASSY.

<u>NO.</u>	<u>PART NO.</u>	<u>ITEM</u>	<u>QTY.</u>	<u>REMARKS</u>
47	0027104016	MACHINE SCREW	2	
48	7451860203	SET BOARD, OUTPUT TERMINAL	1	
49	0801830204	OUTPUT TERMINAL	4	
50	0801830704	HEX. HEAD BOLT	4	
51	0041412000	PLAIN WASHER	16	
52	0040012000	LOCK WASHER	12	
53	0039312000	HEX, .NUT	8	
54	0601805318	CIRCUIT BREAKER	1 S/N3312673~;KM52 265V 20A
55	0041608000	PLAIN WSHER	5	
56	0040008000	LOCK WASHER	5	
57	0010008030	HEX. HEAD BOLT	5	
58	0601811032	RECEPTACLE	2 UP TO S/N3312672; L6-20R 250V 20A
	0601811032	RECEPTACLE	1 S/N3312673~; L620R 250V 20A
59	0601811037	RECEPTACLE	2 UP TO S/N3312672; CS8269 250V 20A
	0601811034	RECEPTACLE	2 S/N3312672~; CS6369 250V 50A
60	0601811031	RECEPTACLE	2 UP TO S/N3312672; L530R 125V 30A
	0601811092	RECEPTACLE	2 S/N3312673~; L520R 125V 20A
61	0601811030	RECEPTACLE	2 5-20R 125V 20Ax2
62	0027103010	MACHINE SCREW	16	
63	0041603000	PLAIN WASHER	16	
64	0030003000	HEX. NUT	16	
65	0601805353	CIRCUIT BREAKER	2 UP TO S/N3312672; KM101 265V 75A
	0601805319	CIRCUIT BREAKER	2 S/N3312673~; KM52 265V 40A
66	0601805306	CIRCUIT BREAKER	2 UP TO S/N3312672; KM51 265V 40A
	0601805311	CIRCUIT BREAKER	2 S/N3312673~; KM51 265V 50A
67	7451816004	BRACKET, CIRCUIT BREAKER	1 UP TO S/N3312672
	7451816014	BRACKET, CIRCUIT BREAKER	1 S/N3312673~
68	0027106016	MACHINE SCREW	2	
69	7451865503	COVER, OUTPUT TERMINAL	1	
70	0805012304	HEX. HEAD BOLT	2	
71	0041612000	PLAIN WASHER	4	
72	0805019704	RUBBER WASHER	2	
73	0030012000	HEX. NUT	2	
74	0605010505	SNAP PIN	2	
75	0601850091	RUBBER CUSHION	2 SK156
76	0021003010	MACHINE SCREW	2	
77	0601802133	FUSE	1 F5 5A
78	0601820015	RECTIFIER	4 1S2762
79	7451865603	COVER, OUTPUT TERMINAL	1 FROM S/N3312331
80	7451855503	HINGE	1 FROM S/N3312331
81	7451855703	HINGE	1 FROM S/N3312331
82	0021304015	MACHINE SCREW	4 FROM S/N3312331
83	0040004000	LOCK WASHER	4 FROM S/N3312331
84	0041204000	PLAIN WASHER	8 FROM S/N3312331
85	0030104000	HEX. NUT	4 FROM S/N3312331
	0030104000	HEX. NUT	4 SN3312672~

BATTERY ASSY.

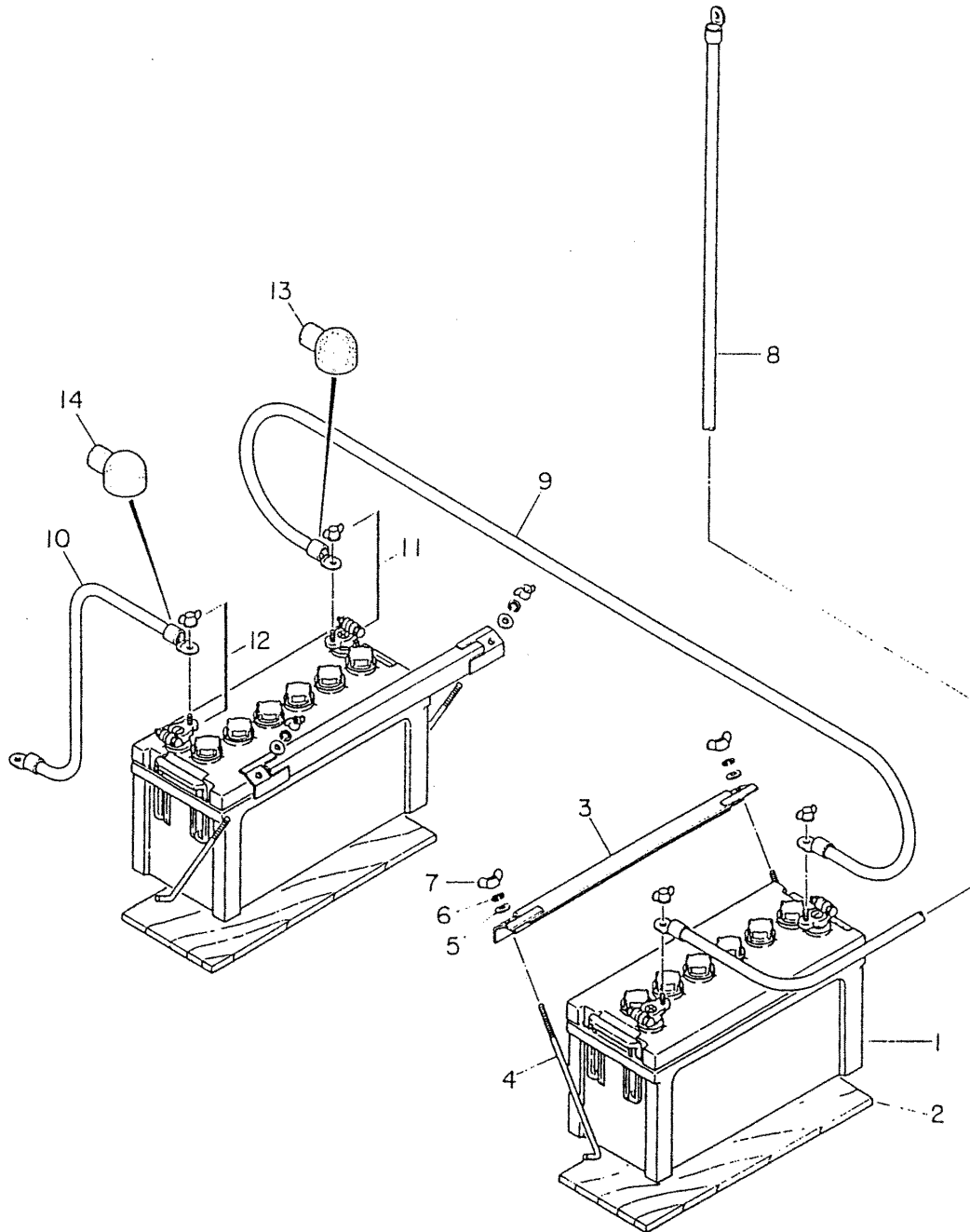

BATTERY ASSY.

<u>NO.</u>	<u>PART NO.</u>	<u>ITEM</u>	<u>QTY.</u>	<u>REMARKS</u>
1	0160012100	BATTERY	2	N1000 12V 100Ah
2	0805003904	BATTERY SHEET	2	
3	0805004004	BATTERY BAND	2	
4	0805002904	BATTERY BOLT	4	
5	0041608000	PLAIN WASHER	4	
6	0040008000	LOCK WASHER	4	
7	0037808000	WING NUT	4	
8	0215260065	BATTERY CABLE	1	
9	02511160180	BATTERY CABLE	1	
10	0215860100	BATTERY CABLE	1	
11	0602220310	TERMINAL ASSY. (+)	2	NO.9P
	0208008000	WING NUT	2	
12	0602220311	TERMINAL ASSY.(-)	2	NO.9N
	0208008000	WING NUT	2	

DCA-60SSAI --- MUFFLER ASSY.

MUFFLER ASSY.

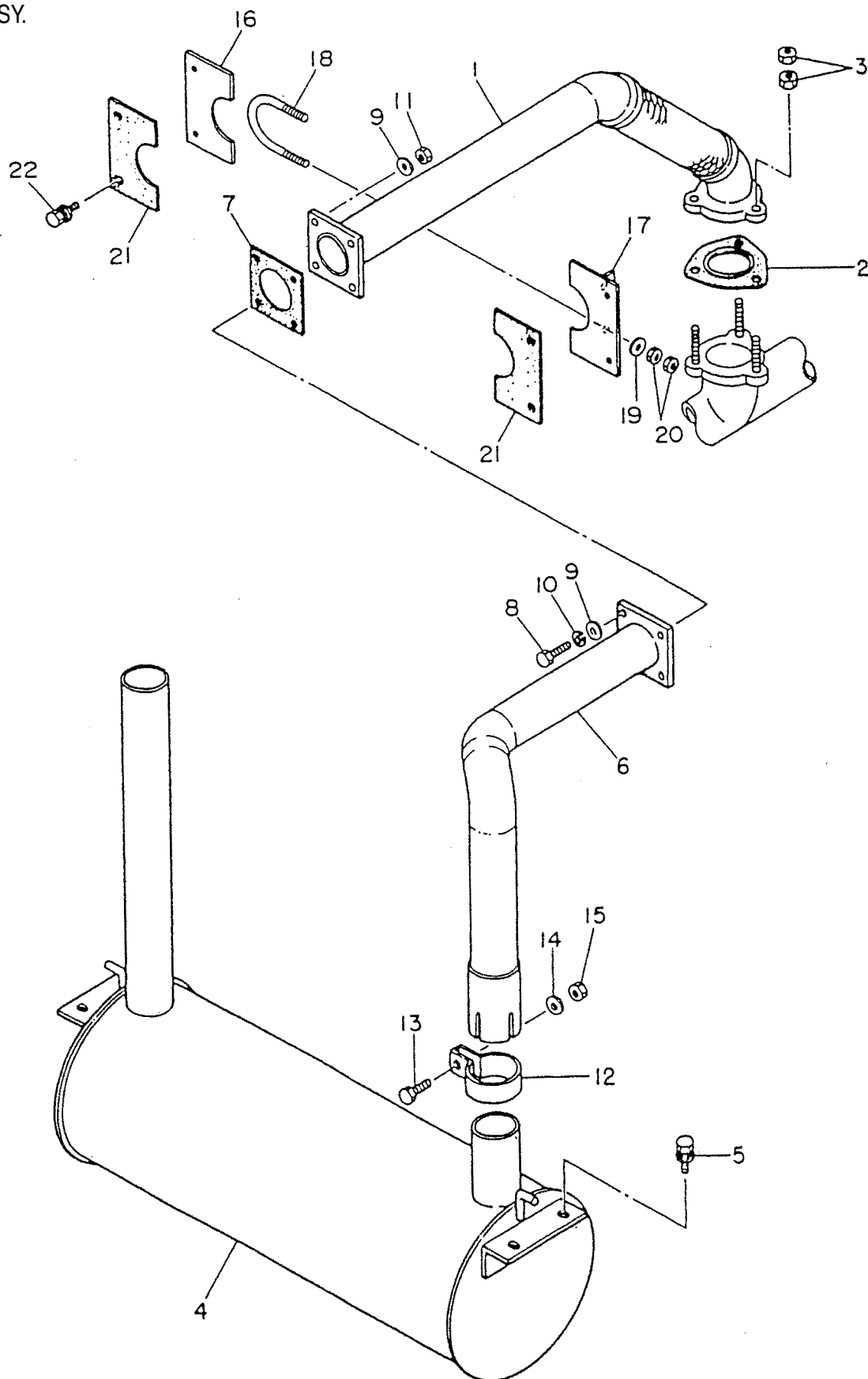

MUFFLER ASSY.

<u>NO.</u>	<u>PART NO.</u>	<u>ITEM</u>	<u>QTY.</u>	<u>REMARKS</u>
1	7452330103	EXHAUST PIPE	1	
2	0602320000	GASKET	1	9221160010
3	0602323002	HEX. NUT	6	9091103100
4	3802311122	MUFFLER	1	
5	0017110020	HEX. HEAD BOLT	4	
6	7452330303	EXHAUST PIPE	1	
7	3342356104	GASKET	1	
8	0010108035	HEX. HEAD BOLT	4	
9	0041608000	PLAIN WASHER	4	
10	0040008000	LOCK WASHER	4	
11	0030008000	HEX. NUT	4	
12	1382320003	PIPE BAND	1	
13	0010008030	HEX. HEAD BOLT	1	
14	0041608000	PLAIN WASHER	1	
15	0030008000	HEX. NUT	1	
16	3342354104	COVER	1	
17	3342354004	COVER	1	
18	3342328104	PIPE CLAMPER	1	
19	0030008000	HEX. NUT	4	
20	3342359004	COVER SHEET	2	
21	0017108025	HEX. HEAD BOLT	4	

DCA-60SSAI --- FUEL TANK ASSY.

FUEL TANK ASSY.

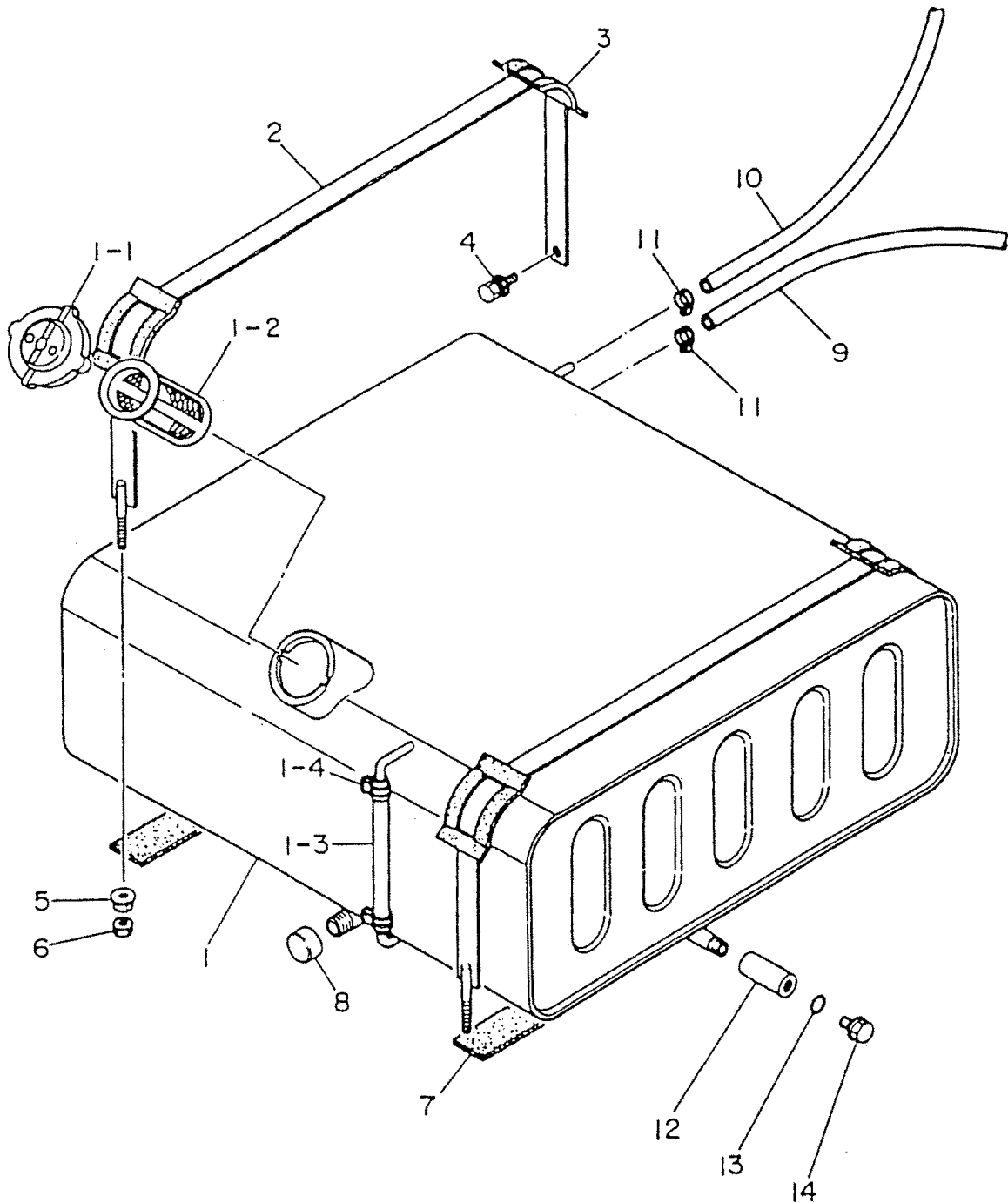

DCA-60SSAI --- FUEL TANK ASSY.

FUEL TANK ASSY.

<u>NO.</u>	<u>PART NO.</u>	<u>ITEM</u>	<u>QTY.</u>	<u>REMARKS</u>
1	7455510123	FUEL TANK	1	UP TO S/N3312672
	7455510303	FUEL TANK	1	S/N3312673~
1-1	0810105004	CAP, FUEL TANK	1	
1-2	0810105400	FUEL FILTER	1	
2	0802010304	PACKING	1	UP TO S/N3312672
3	0602021042	PLUG	1	UP TO S/N3312672; 960922101
4	7455523104	TANK BAND	2	UP TO S/N3312672
	7455523304	TANK BAND	2	S/N3312673~
5	0805003404	PAD, TANK BAND	4	
6	0017108020	HEX. HEAD BOLT	2	
7	0041608000	PLAIN WASHER	2	
8	0040008000	LOCK WASHER	2	
9	0030008000	HEX. NUT	2	
10	3805522004	TANK SHEET	4	
11	0191300530	SUCTION HOSR	1	
12	0191300650	RETURN HOSE	1	
13	0605515014	HOSE BAND	4	
14	0845032204	DRAIN JOINT	1	
15	0150000018	O RING	1	
16	0802011104	PLUG	1	
17	0193100255	FUEL GAUGE HOSE	1	
18	0605515079	HOSE BAND	2	
19	0131906000	CAP	1	S/N3312673~

ENCLOSURE ASSY.

DCA-60SSAI --- ENCLOSURE ASSY.

ENCLOSURE ASSY.

<u>NO.</u>	<u>PART NO.</u>	<u>ITEM</u>	<u>QTY.</u>	<u>REMARKS</u>
1	7455111012	BASE	1 UP TO S/N3312672
	7455111102	BASE	1 S/N3312673~
2	7455109104	ACOUSTIC SHEET	1	
3	7455116004	FLOOR PANEL	1	
	0017108020	HEX. HEAD BOLT	12	
5	7455121012	FRONT FRAME	1	
6	7455109203	ACOUSTIC SHEET	1	
7	7450630503	STRIPE, LEFT SIDE	1	
8	7450630703	STRIPE, RIGHT SIDE	1	
9	6360510003	EMBLEM	2	
10	0021106020	MACHINE SCREW	4	
11	0017108020	HEX. HEAD BOLT	6	
12	0800251201	FILTER COVER	1	
13	0027106016	MACHINE SCREW	2	
14	7455125003	COVER, FRONT FRAME	1 UP TO S/N3312672
	7455125503			
15	7455109304	ACOUSTIC SHEET	1	
16	7450630303	STRIPE	1	
17	0017108020	HEX., HEAD BOLT	16	
18	7455125303	COVER, FRONT FRAME	1	
19	0017108020	HEX.HEAD BOLT	12	
20	3385155104	COVER	2	
21	0017106020	HEX. HEAD BOLT	8	
22	7455125104	COVER, FROT FRAME	1	
23	7455109404	ACOUSTIC SHEET	1	
24	0017108020	HEX. HEAD BOLT	6	
25	7455125204	COVER, FRONT FRAME	1 UP TO S/N3312672
	7455125704	COVER, FRONT FRAME	1 S/N3312673~
26	7455109504	ACOUSTIC SHEET	1	
27	0017108020	HEX. HEAD BOLT	4	
28	7455132013	CENTER FRAME	1	
29	7455132203	CENTER FRAME	1	
30	00101141040	HEX. HEAD BOLT	8	
31	0041614000	PLAIN WASHER	16	
32	0040014000	LOCK WASHER	8	
33	0030014000	HEX. NUT	8	
34	0010012030	HEX. HEAD BOLT	10	
35	0040012000	LOCK WASHER	10	
36	0041612000	PLAIN WASHER	10	

ADD THE FOLLOWING DIGITS AFTER THE PART NUMBER
WHEN ORDERING ANY PAINTED PANEL TO
INDICATE COLOR OF UNIT:
1-ORANGE 5 -BLACK
2-WHITE 6 -CATERPILLAR YELLOW
3 -SPECTRUM GRAY 7 -CATO GOLD
4 -SUNBELT GREEN 8 -RED

THE SERIAL NUMBER MAY BE REQUIRED.

ENCLOSURE ASSY.

DCA-60SSAI --- ENCLOSURE ASSY.

ENCLOSURE ASSY.

<u>NO.</u>	<u>PART NO.</u>	<u>ITEM</u>	<u>QTY.</u>	<u>REMARKS</u>
37	7455141102	REAR FRAME	1 UP TO S/N3311616
	7455141112	REAR FRAME	1 S/N3312178~
38	7455109603	ACOUSTIC SHEET	1	
39	7450630904	STRIPE	2	
40	0017108020	HEX. HEAD BOLT	4	
41	7455155003	COVER, REAR FRAME	1	
42	7455109703	ACOUSTIC SHEET	1	
43	0041608000	PLAIN WASHER	8	
44	0040008000	LOCK WASHER	8	
45	0010008040	HEX. HEAD BOLT	8	
46	7455143103	DOOR, REAR FRAME	1 UP TO S/N3311616
	7455143113	DOOR, REAR FRAME	1 S/N3312178~
47	1320632003	STICKER	1	
48	3805147104	WINDOW PLATE	1	
49	0021006020	MACHINE SCREW	6	
50	0041606000	PLAIN WASHER	6	
51	0040006000	LOCK WASHER	6	
52	0030006000	HEX. NUT	6	
53	0845028303	HINGE	2	
54	0017108025	HEX. HEAD BOLT	4	
55	7455161012	ROOF PANEL	1	
56	7455109803	ACOUSTIC SHEET	1	
57	0017108020	HEX. HEAD BOLT	16	
58	7455165004	GUIDE PANEL, AIR	2	
59	7455109904	ACOUSTIC SHEET	2	
60	0017108020	HEX. HEAD BOLT	8	
61	7455181202	SPLASHER PANEL	1 UP TO S/N3312672
	7455181212	SPLASHER PANEL	1 S/N3312673~
62	7455105004	ACOUSTIC SHEET	1	
63	0010008055	HEX. HEAD BOLT	6	
64	0040008000	LOCK WASHER	6	
65	001608000	PLAIN WASHER	6	

ADD THE FOLLOWING DIGITS AFTER THE PART NUMBER
WHEN ORDERING ANY PAINTED PANEL TO
INDICATE COLOR OF UNIT:
1-ORANGE 5 -BLACK
2-WHITE 6 -CATERPILLAR YELLOW
3 -SPECTRUM GRAY 7 -CATO GOLD
4 -SUNBELT GREEN 8 -RED

THE SERIAL NUMBER MAY BE REQUIRED.

RUBBER SEAL ASSY.

DCA-60SSAI --- RUBBER SEAL ASSY.

RUBBER SEAL ASSY.

<u>NO.</u>	<u>PART NO.</u>	<u>ITEM</u>	<u>QTY.</u>	<u>REMARKS</u>
66	7455171403	SIDE DOOR, LEFT SIDE	1 UP TO S/N3311616
	7455171413	SIDE DOOR, LEFT SIDE	1 S/N3312178~
67	7455105104	ACOUSTIC SHEET	1	
68	7455171503	SIDE DOOR, RIGHT SIDE	1 UP TO S/N3311616
	7455171513	SIDE DOOR, RIGHT SIDE	1 S/N3312178~
69	7455105204	ACOUSTIC SHEET	1	
70	7450631104	STRIPE	2	
71	7455171603	SIDE DOOR, LEFT SIDE	1 UP TO S/N3311616
	7455171613	SIDE DOR, LEFT SIDE	1 S/N3312178~
72	7455105304	ACOUSTIC SHEET	1	
73	7450631304	STRIPE	1	
74	7455171703	SIDE DOOR, RIGHT SIDE	1 UP TO S/N3311616
	7455171713	SIDE DOOR, RIGHT SIDE	1 S/N3312178~
75	7455105404	ACOUSTIC SHEET	1
76	7450631504	STRIPE	1	
77	0845028203	HINGE	4	
78	0845028303	HINGE	4	
79	0017108025	HEX. HEAD BOLT	16	
80	0845031504	CAP	10	
81	0605010910	LATCH	1 UP TO S/N3311616
82	0027103010	MACHIEN SCREW	7 UP TO S/N3311616
83	0605010911	LATCH	2 UP TO S/N3311616
84	0027104010	MACHIEN SCREW	14 UP TO S/N3311616
85	7455104104	RUBBER SEAL	2	
86	7455104204	RUBBER SEAL	2	
87	7455104304	RUBBER SEAL	3	
88	7455104404	RUBBER SEAL	1	
89	7455104504	RUBBER SEAL	1	
90	7455104604	RUBBER SEAL	1	
91	7455104704	RUBBER SEAL	1	
92	7455104804	RUBBER SEAL	2	
93	7455104904	RUBBER SEAL	2	
94	7455116504	COVER	1 S/N3312673~
95	0017108020	HEX. HEAD BOLT	2 S/N3312673~

DECAL ASSY.

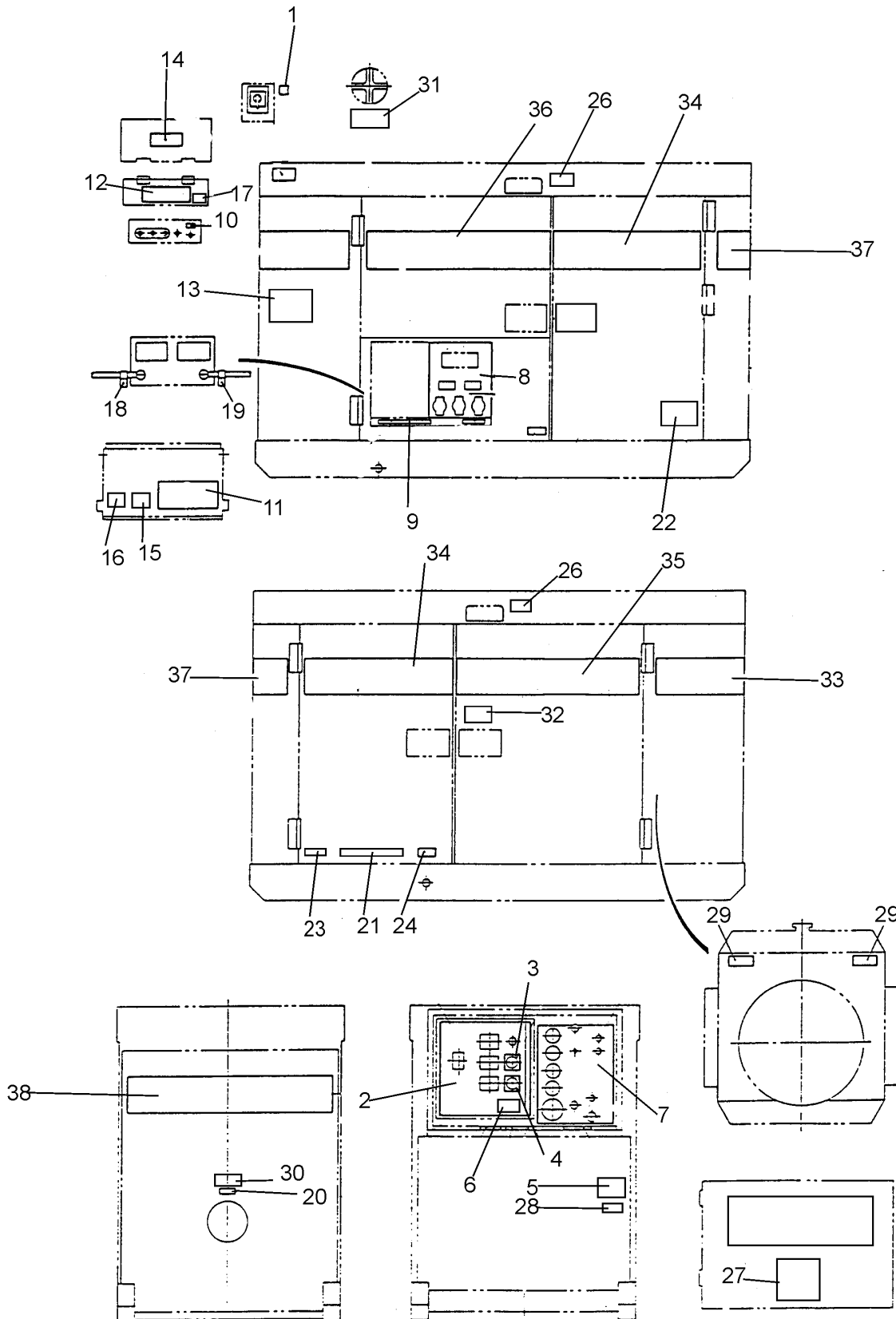

DECAL ASSY.

<u>NO.</u>	<u>PART NO.</u>	<u>ITEM</u>	<u>QTY.</u>	<u>REMARKS</u>
1	B9521100504	DECAL; CAUTION	1	B92110050
2	B4551005902	DECAL; CONTROL PANEL	1	B45100590
3	0800520904	PLATE; AMMETER CHANGE-OVER SWITCH	1	N2438
4	0800520804	PLATE; VOLTAGE CHANGE-OVER SWITCH	1	N2439
5	B9521100404	DECAL; SAFETY INSTRUCTION	1	B92110040
6	B9531100604	DECAL; WARNING	1	B93110060
7	3340670002	DECAL; OPERATING PANEL	1	S2361A
8	8050670113	DECAL; RECEPTABLE & CIRCUIT BREAKER	1	S3349A
9	B1551001604	DECAL; NOTE	1	B15100160
10	0840614104	DECAL; GROUND MARK	1	S2635
11	0840619904	DECAL; CAUTION	1	S2731
12	0840627103	DECAL; CABLE JOINING	1	S3245
13	8080670514	DECAL; CAUTION	1	S3696B
14	B9531100604	DECAL; WARNING ELECTRIC SHOCK HAZARD ...	1	B93110060
15	B9511100404	DECAL; WARNING ELECTRIC SHOCK HAZARD ...	1	B91110040
16	B9531100504	DECAL; WARNING ELECTRIC SHOCK HAZARD ...	1	B93110050
17	B9511100304	DECAL; WARNING	1	B91110030
18	0800689404	DECAL; +	1	S2090
19	0800689504	DECAL; -	1	S2091
20	1320620904	DECAL; DIESEL FUEL	1	S1756
21	1320610603	DECAL; WATER, OIL	1	S1760
22	6360610304	DECAL; WATER	1	S1880
23	6360620004	DECAL; FUEL DRAIN PLUG	1	S1883
24	6360620204	DECAL; OIL DRAIN PLUG	1	S1885
25	0840627304	DECAL; WARNING	1	S3247
26	1320621504	DECAL; SUPPORT HOOK	2	S2257
27	0840625902	DECAL; MQ	1	S3057
28	B9504200004	DECAL; WARNING ENGINE EXHAUST	1	B90420000
29	B9504000404	DECAL; WARNING MOVING PARTS	2	M90400040
30	B9504500004	DECAL; WARNING DIESEL FUEL	1	B90450000
31	B9504100104	DECAL; WARNING HOT COOLANT	1	B90410010
32	B9504000304	DECAL; CAUTION HOT PARTS	1	B90400030
33	7450630703	STRIPE	1	REPLACES B4561100103
34	B4561100403	STRIPE	2	
35	B4561100503	STRIPE	1	
36	B4561100604	STRIPE	1	
37	B4561100304	STRIPE	2	
38	B4561100003	STRIPE	1	

ISUZU 6BD1 — CYLINDER HEAD COVER ASSY.

CYLINDER HEAD COVER ASSY.

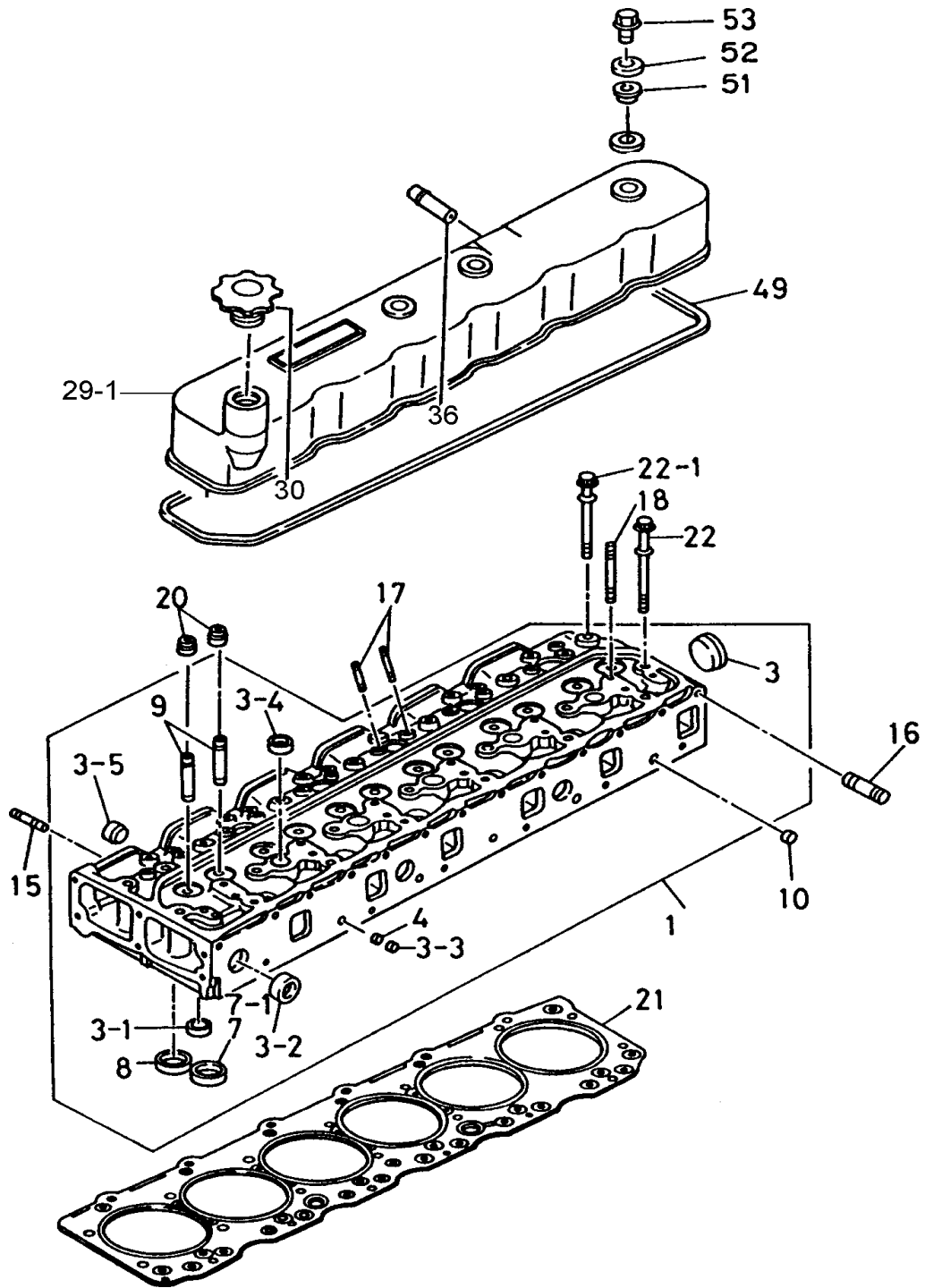

ISUZU 6BD1 — CYLINDER HEAD COVER ASSY.

CYLINDER HEAD COVER ASSY.

<u>NO</u>	<u>PART NO</u>	<u>PART NAME</u>	<u>QTY.</u>	<u>REMARKS</u>
1	1111105271	CYLINDER HEAD	1	UP TO AUG. 85; REPLACES 1111105270
	1111106141	CYLINDER HEAD	1	AUG. 85~; INCL. ITEMS W/#
3#	1096000051	REAR SEALING CUP, D=44.5	1	
3-1#	9111291280	LOWER SEALING CUP, D=20	3	
3-2#	5112190150	EXH. SEALING CUP, D=31.75	3	
3-3#	5096000130	DRILLED SEALING CUP, D=12	6	REPLACES 9111296010
3-4#	1096000160	TOP FACE SEALING CUP, D=25	5	
3-5#	1096000160	INL. MAN. SEALING CUP	6	
4#	9096600340	PLUG	6	
7#	9117156070	INLET VALVE SEAT INSERT	6	UP TO APR. 85
	1117150540	INLET VALVE SEAT INSERT	6	MAY 85~
8#	1117110260	EXH. VALVE SEAT INSERT	6	UP TO JUL. 85
	1117110430	EXH. VALVE SEAT INSERT	6	AUG. 85~
9#	5117210010	VALVE GUIDE, EXH. & INL.	12	
10	9111296010	SEALING CUP, DRILLED D=12	5	
15	9041108250	INLET MANIFOLD STUD	3	
16	9041108750	EXH. MANIFOLD STUD	9	
	9098301790	EXH. MANIFOLD STUD, L1=88	2	
	9096300260	EXH. MANIFOLD STUD, L1=86	12	
17	1093000180	NOZZLE HOLDER STUD, L1=40	12	
18	9098301630	ROCKER ARM NUT STUD, L1=83	4	
20	5125690010	VALVE GUIDE, INL & EXH. SEAL	12	UP TO JUL. 85
	1125690150	VALVE GUIDE, INL & EXH. SEAL	12	AUG. 85~
21	1111410902	CYLINDER HEAD GASKET	1	AUG. 84. TO AUG. 85
	1111411950	CYLINDER HEAD GASKET	1	AUG. 85~; REPLACES 1111411710
22	5090090180	BOLT, L=115	20	UP TO SEPT. 88
	1090701010	BOLT, L=113	20	OCT. 88~; REPLACES 1090700630
22-1	5090090170	BOLT, L=102	6	UP TO JUL. 84
	1090390030	BOLT, L=106	6	AUG. 84~JUL. 86
	1090701000	BOLT, L=100	6	JUL. 86~; REPLACES 1090700620
29-1	1111709281	CYL. HEAD COVER ASSY.	1	
29-2	1111801531	CYL. HEAD COVER ASSY.	1	
30	9117510381	OIL FILLER CAP	1	
36	5111790520	BREATHER HOSE NIPPLE	1	REPLACES 9143193681
49	1111730590	CYL. HEAD COVER PACKING	1	
51	9111790300	COVER PACKING	4	
52	9111791050	WASHER	4	
53	9111750110	NUT	4	

ISUZU 6BD1 — CYLINDER BLOCK ASSY.

CYLINDER BLOCK ASSY.

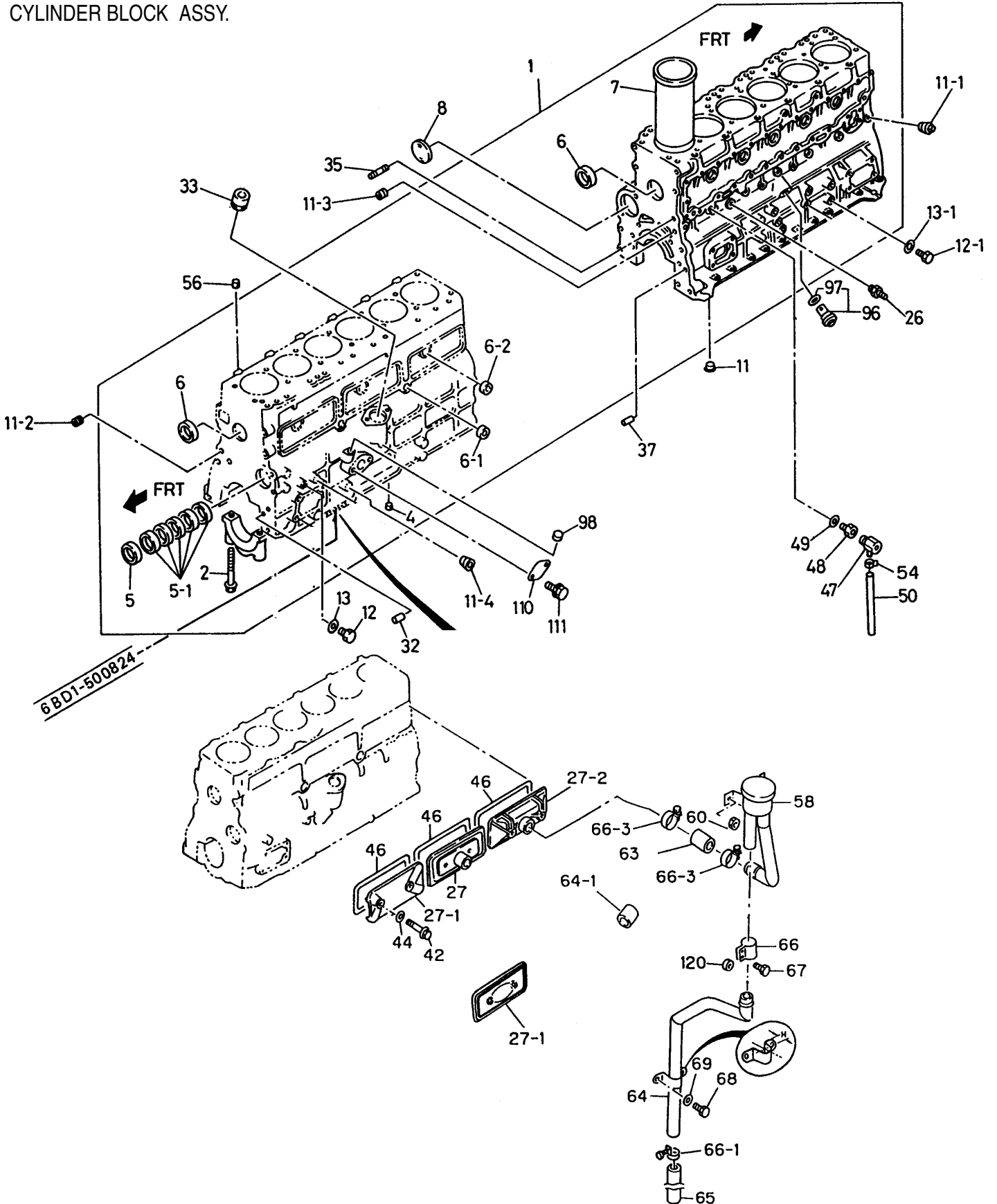

ISUZU 6BD1 — CYLINDER BLOCK ASSY.

CYLINDER BLOCK ASSY.

<u>NO.</u>	<u>PART NO.</u>	<u>PART NAME</u>	<u>QTY.</u>	<u>REMARKS</u>
1	1112102790	CYLINDER BLOCK ASSY.....	1	UP TO S/NE518004; INCL. ITEMS W/#
	1112103324	CYLINDER BLOCK ASSY.....	1	REPLACES 1112103320
2#	1090004691	BOLT	14	REPLACES 5090001330
4#	8943706360	BRIDGE CAP NO.4 DOWEL	1	REPLACES 5112570010; UP TO MAY 89
	5112570010	BRIDGE CAP NO. 4 DOWEL	1	JUNE 89~
5#	9116110480	FRONT CAM METAL	1	REPLACES 911690480
5-1#	9116130350	INNER AND REAR CAM METAL	5	REPLACES 9116930350
6#	1096000520	SEALING FACE CUP, D=60	2	
6-1#	5112190140	LEFT SEALING CUP, D=28	2	
6-2#	1096000121	TAPPET CHAMBER SEALING CUP	3	
7#	1112611180	CYLINDER LINER	6	REPLACES 5112610040
8#	9098600190	REAR END CAMSHAFT PLUG	1	
11	1096050660	OIL GALLERY PLUG, PT 3/8	1	
11-1	5096050180	OIL GALLERY PLUG, PT 1/8	10	
11-2	1096050681	FRONT OIL GALLERY PLUG, PT 1/2	1	
11-3	1096050681	REAR OIL GALLERY PLUG, PT 1/2	1	
11-4	1096050791	TURBO FEEDING PLUG	1	
12	9992023140	CYL. BLOCK PLUG, LEFT SIDE	1	
12-1	9992023120	CYL. BLOCK PLUG, RIGHT SIDE	1	
13	9095714140	PLUG PACKING, LEFT SIDE	1	
13-1	9095714120	PLUG PACKING	1	
26	5096540130	NIPPLE, INJ. PUMP, PT 1/8	1	
27	9112916050	TAPPET CHAMBER COVER	1	
27-1	1112910441	TAPPET CHAMBER COVER	1	
27-2	5112901450	TAPPET CHAMBER COVER ASSY.	1	
32	1097400780	TIMING GEAR CASE PIN	1	REPLACES 9081510500
33	9112246021	OIL PUMP DRIVE SHAFT BUSHING	1	
35	5093000231	FLYWHEEL HOUSING STUD	1	
37	9081510180	FLYWHEEL HOUSING PIN	2	
42	1090520211	CHAMBER COVER FIXTURE	2	REPLACES 1090520221
44	9095720080	CHAMBER COVER PACKING	6	
46	1112920200	CYLINDER BLOCK COVER PACKING	3	
47	1096800240	WATER DRAIN COCK ASSY.	1	
48	1096660360	DRAIN COCK JOINT	1	
49	1096301150	WATER DRAIN COCK PACKING	1	REPLACES 9099212420
50	9099148600	VINYL PIPE WITH DRAIN, L=510	1	
54	8970157540	RUBBER HOSE CLIP	1	
56	9112298010	CYLINDER HEAD DOWEL	2	
58	5117401220	AIR BREATHER ASSY.	1	
60	9091105080	NUT	2	REPLACES 9091104080

ISUZU 6BD1 — CYLINDER BLOCK ASSY.

CYLINDER BLOCK ASSY.

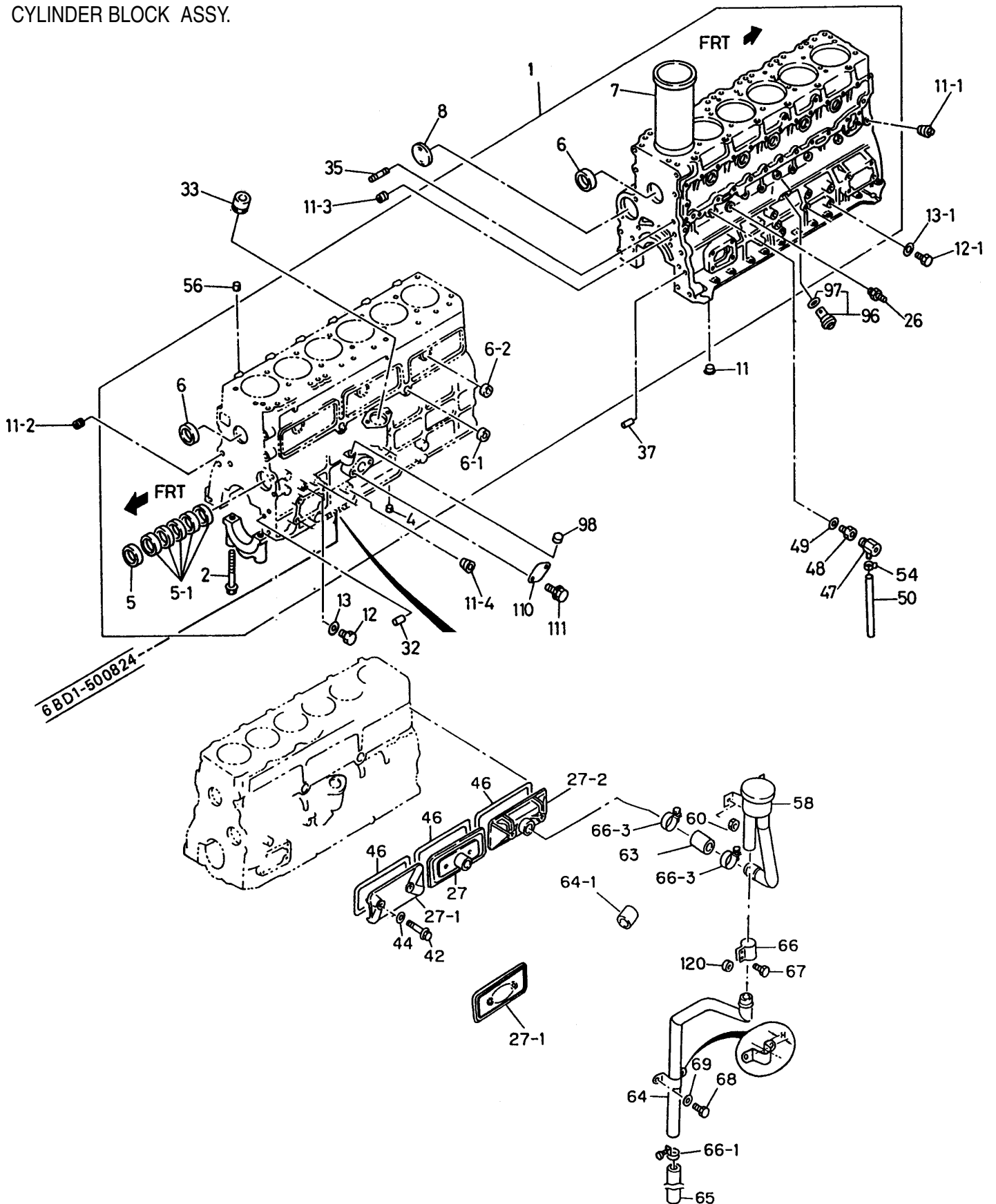

ISUZU 6BD1 — CYLINDER BLOCK ASSY.

CYLINDER BLOCK ASSY.

<u>NO.</u>	<u>PART NO.</u>	<u>PART NAME</u>	<u>QTY.</u>	<u>REMARKS</u>
61	9091505080	LOCK WASHER	2	
63	1093604390	BREATHER COVER HOSE	1	
64	9117426140	DRAIN PIPE, H=32	1	UP TO MAR. 84
	1117420211	DRAIN PIPE, H=26	1	APR. 84~
61-1	5093609780	RUBBER	1	
65	9097130740	HOSE	1	
66	9097150670	CLIP	1	
66-1	9099156661	CLIP	1	
66-3	1097040570	CLIP	2	
67	0208006250	BOLT	2	REPLACES 9020406250
68	0208008140	BOLT	2	REPLACE 9020508140
69	9091505080	LOCK WASHER	2	
96	8970233390	OIL RELIEF VALVE ASSY.	1	REPLACES 9131606062; INCL. ITEMS W/&
97&	5096230350	VALVE PACKING	1	
98	5111290030	SEALING CUP	1	
110	1112190983	OIL PORT COVER	1	UP TO JUL. 90
	1112191630	OIL PORT COVER	1	AUG. 90~
111	9019708180	BOLT	2	UP TO JUL. 90; REPLACES 0501408180
	0501408200	BOLT	2	AUG. 90~
120	8942351570	DISTANCE CLIP PIECE	2	NOT SHOWN

ISUZU 6BD1 —TIMING GEAR CASE ASSY.

TIMING GEAR CASE ASSY.

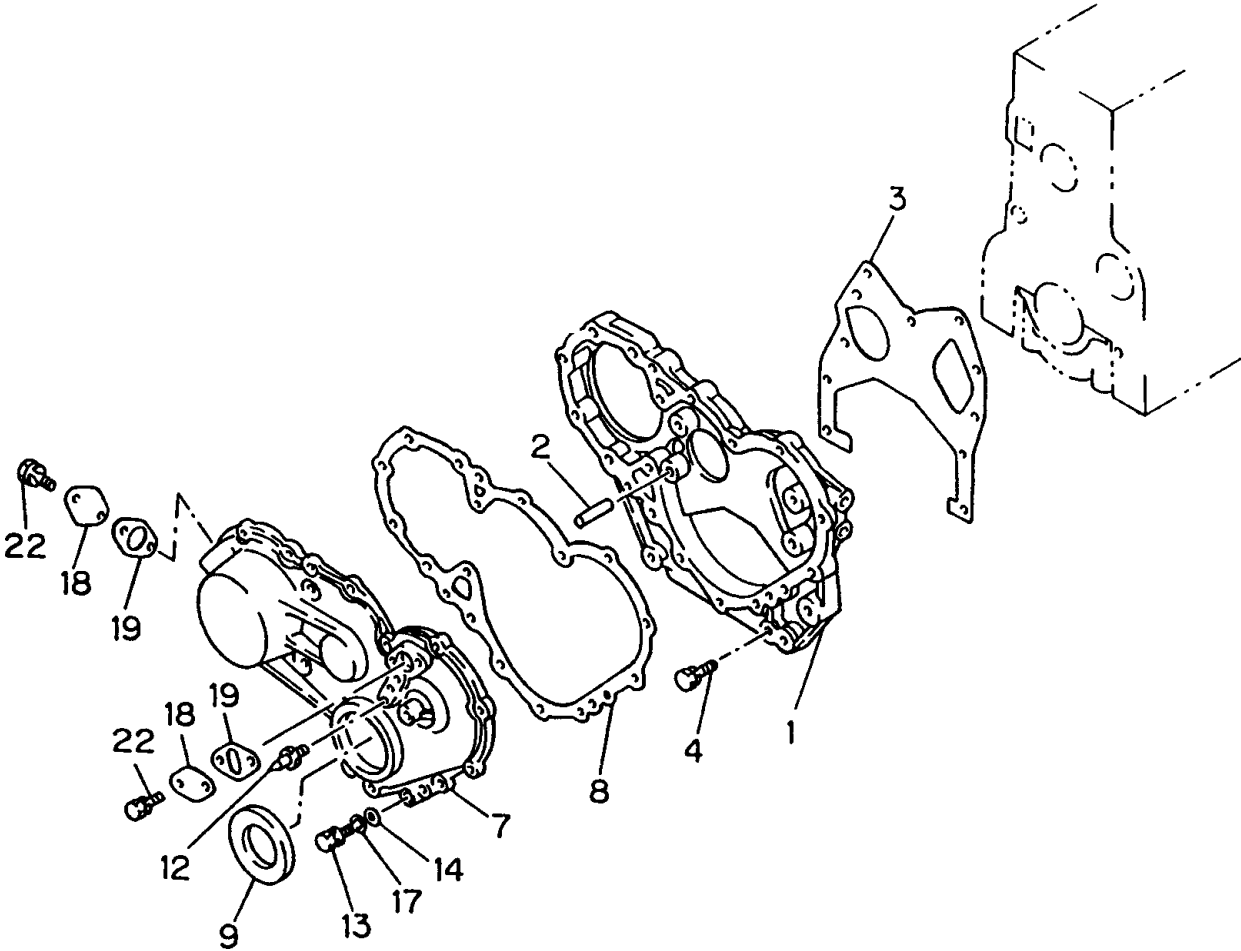

ISUZU 6BD1 — TIMING GEAR CASE ASSY.

TIMING GEAR CASE ASSY.

<u>NO.</u>	<u>PART NO.</u>	<u>PART NAME</u>	<u>QTY.</u>	<u>REMARKS</u>
1	5113110113	TIMING GEAR CASE	1	
2	9081510180	STRAIGHT PIN	1	
3	1113120140	GEAR PACKING	1	REPLACES 1113120100
4	0500408450	BOLT	2	REPLACES 9019108450
	0500408200	BOLT	4	REPLACES 9019108200
7	1113210790	GEAR CASE COVER	1	
8	1113220360	GEAR CASE PACKING	1	UP TO JUN. 90
	8943632690	GEAR CASE PACKING	1	JUL. 90~
9	5096250540	CRANKSHAFT OIL SEAL	1	UP TO OCT. 87
	1096254380	CRANKSHAFT OIL SEAL	1	NOV. 87~; REPLACES 1096253190
12	5113270090	TIMER POINTER; L1=33	1	
13	0501408250	BOLT	7	REPLACES 9019708250
	5090000841	BOLT	5	REPLACES 9010558550
14	9091605080	PLAIN WASHER	5	
17	9091505080	LOCKWASHER	5	
18	5113210090	TIMING CHECK COVER	2	
19	1112820130	COVER PACKING	2	REPLACES 1112820090
22	0500406140	BOLT	4	REPLACES 9019006140

ISUZU 6BD1 — FLYWHEEL HOUSING ASSY.

FLYWHEEL HOUSING ASSY.

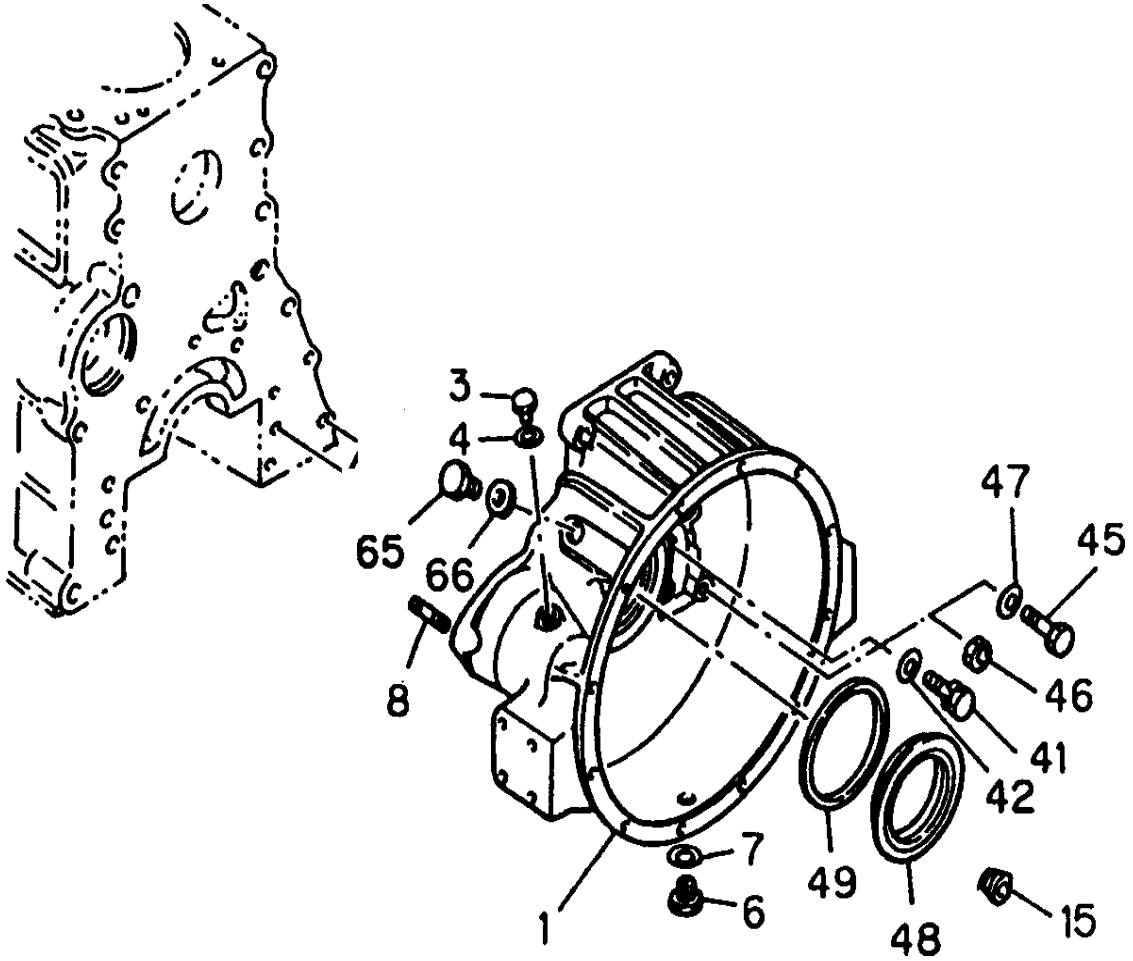

ISUZU 6BD1 — FLYWHEEL HOUSING ASSY.

FLYWHEEL HOUSING ASSY.

<u>NO.</u>	<u>PART NO.</u>	<u>PART NAME</u>	<u>QTY.</u>	<u>REMARKS</u>
1	9113416098	FLYWHEEL HOUSING	1	
6	9992023160	DRAIN PLUG	1	
7	9095714160	DRAIN PLUG PACKING	1	
8	9944112350	NUT	3	REPLACES 9944112280
15	992023160	PLUG	1	
41	0500408250	BOLT	7	REPLACE 9019108250
45	9910664500	BOLT	5	REPLACES 9910664500
46	999104140	NUT	1	
47	9096510690	PLAIN WASHER	8	
48	5096250141	OIL SEAL	1	UP TO MAR. 84
	1096253620	OIL SEAL	1	APR. 84~
49	9123631460	OIL SEAL SPACER	1	

ISUZU 6BD1 —OIL PAN ASSY.

OIL PAN ASSY.

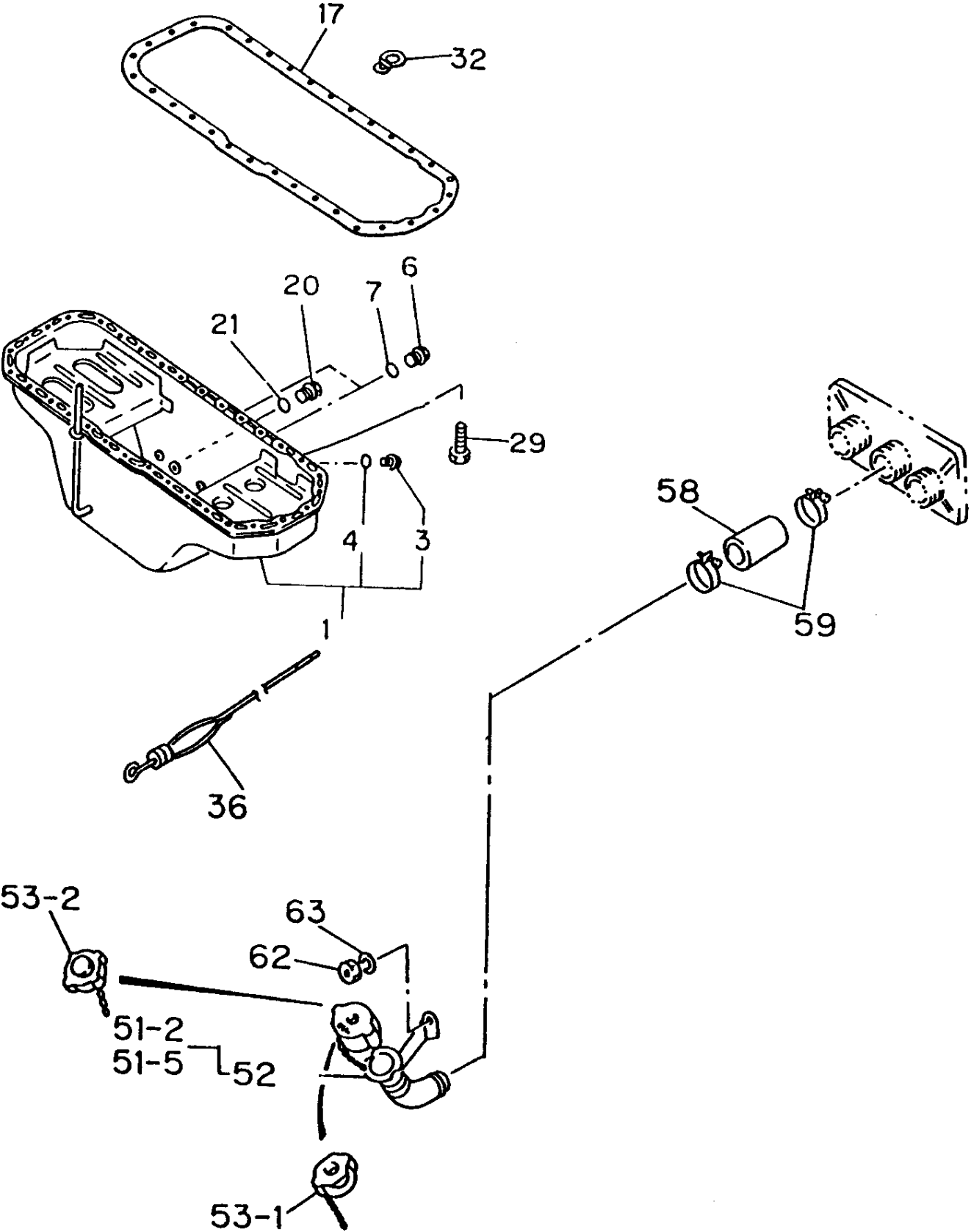

OIL PAN ASSY.

<u>NO</u>	<u>PART NO</u>	<u>PART NAME</u>	<u>QTY.</u>	<u>REMARKS</u>
1	1113604421	OIL PAN	1	INCL. ITEMS W/#
3#	9096620120	PLUG, M=20	1	
4#	1096230570	PACKING, ID=24	1	REPLACES 1096231830
6	9992023160	OIL PAN PLUG	1	
7	9095714160	OIL PAN PACKING	1	
17	1113670961	CYL. BLOCK PACKING	1	REPLACES 1113670720
20	9992023240	OIL PAN PLUG	1	
21	9095714240	OIL PAN PACKING	1	
29	0500408180	BOLT	32	REPLACES 9019108180
32	9112290700	CLIP	1	
36	1117602000	OIL LEVEL GAUGE	1	
51-2	5117401102	OIL FILLER ASSY.	1	INCL. ITEMS W/;&; UP TO APR. 89
51-5	1117402011	OIL FILLER ASSY.	1	INCL. ITEMS W/;&; MAY 89~
52&	5117410131	OIL FILLER	1	
53&	1117500060	CAP	1	REPLACES 1117500120; UP TO APR. 89
53-2	1117500241	OIL FILLER CAP	1	MAY 89~
58	9099129760	RUBBER HOSE	1	
59	9099155531	CLIP	2	
62	9091104080	NUT	1	
63	9091505080	LOCK WASHER	1	

ISUZU 6BD1 — OIL PUMP ASSY.

OIL PUMP ASSY.

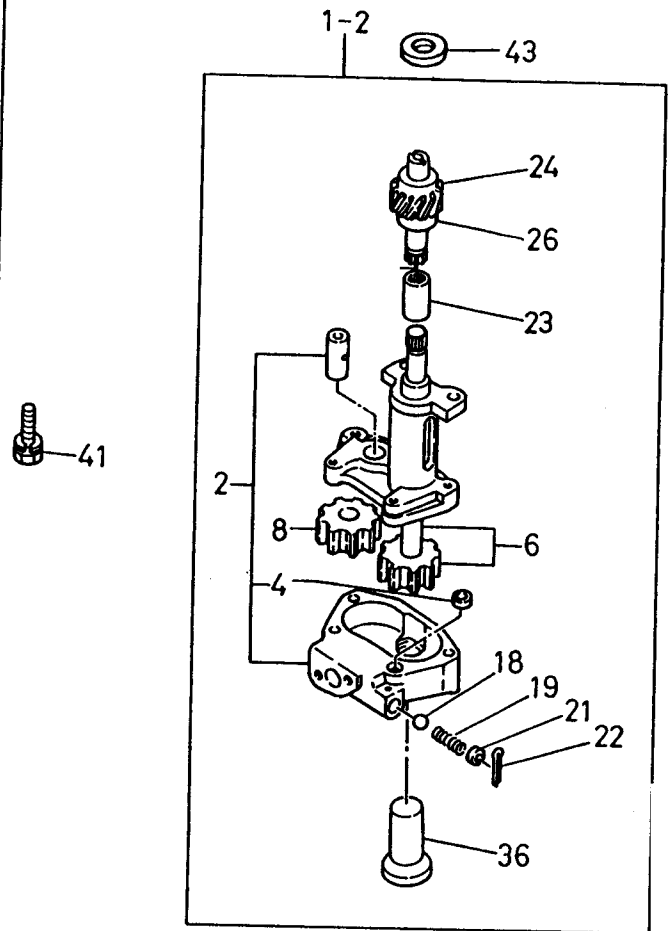
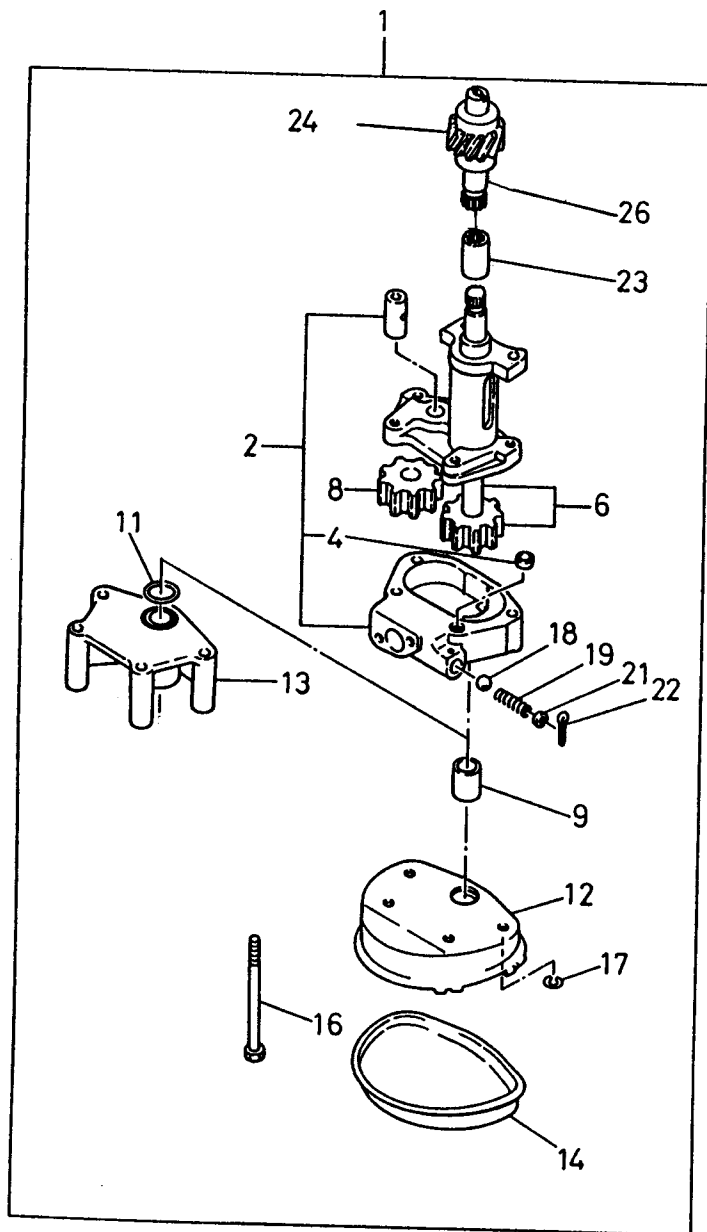

ISUZU 6BD1 — OIL PUMP ASSY.

OIL PUMP ASSY.

<u>NO.</u>	<u>PART NO.</u>	<u>PART NAME</u>	<u>QTY.</u>	<u>REMARKS</u>
1	5131000913	OIL PUMP	1	UP TO AUG. 88; INCL. ITEMS W/#
1-2	1131002330	OIL PUMP	1	SEP. 88~; INCL. ITEMS W/&
2#&	1131130470	COVER	1	INCL. ITEMS W/\$
4#&\$	1131190030	DOWEL	1	
6#&	5131210050	GEAR ASSY.	1	
8#&	5131250010	GEAR	1	
9#	5131190020	PIPE	1	
11#	9095612230	O RING	1	
12#	1131410210	TOP CASE	1	
13#	1131190020	OIL SPACER	1	
14#	5131410020	BOTTOM CASE	1	
16#	9098010741	BOLT, L=115	4	
16-2#	1090440470	BOLT, L=60	4	
17#	9091505080	LOCK WASHER	4	
18#&	5098430030	BALL	1	
19#&	5095800980	SPRING	1	
21#&	5131650040	VALVE SEAT	1	
22#&	9081040300	VALVE PIN	1	
23#&	1131230160	COUPLING	1	
24#&	1131280180	PINION	1	
26#&	9131190100	COLLAR	1	
36#&	1131400860	STRAINER ASSY.	1	
41	0500410250	BOLT	2	REPLACES 9019110250
43	9131190100	COLLER	1	

ISUZU 6BD1 — CRANKSHAFT ASSY.

CRANKSHAFT ASSY.

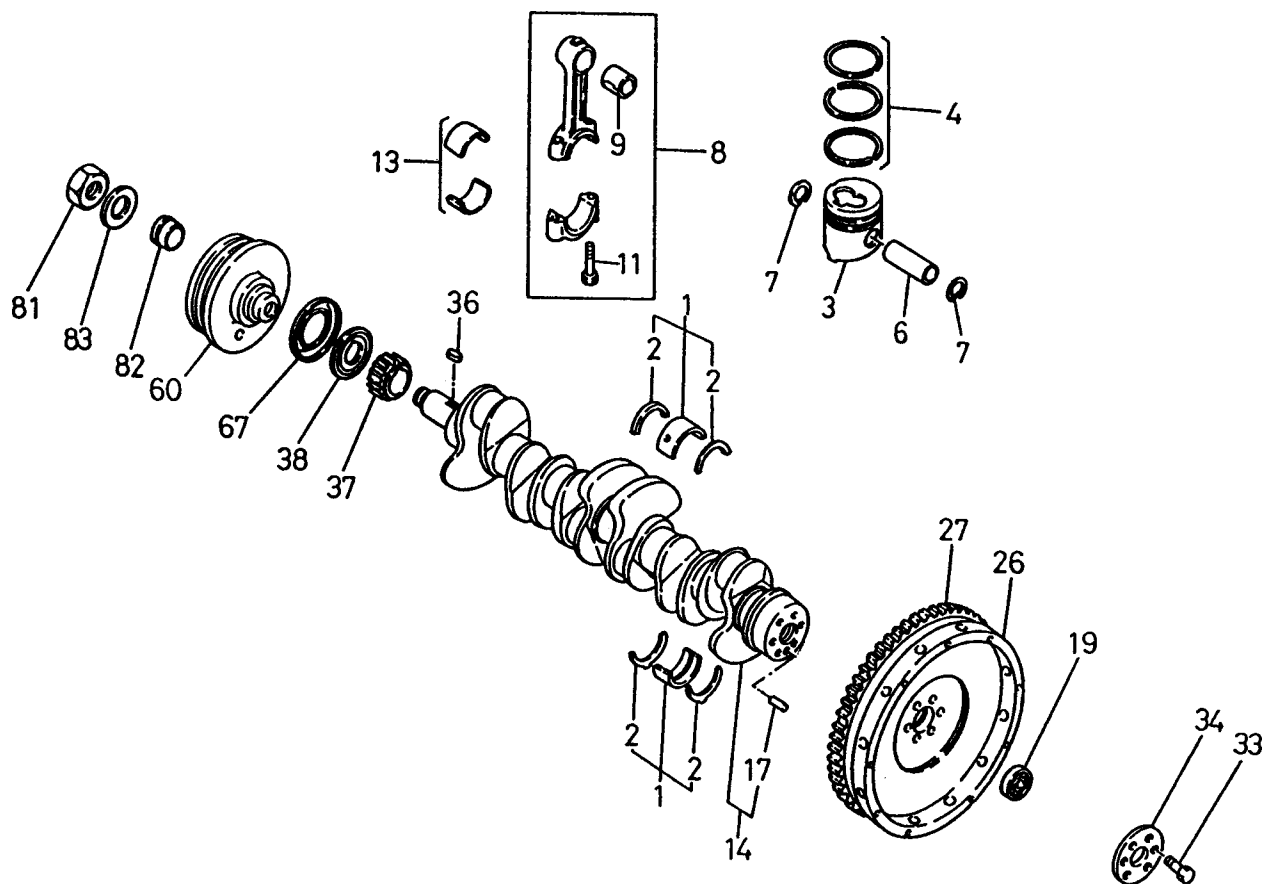

ISUZU 6BD1 — CRANKSHAFT ASSY.

CRANKSHAFT ASSY.

<u>NO.</u>	<u>PART NO.</u>	<u>PART NAME</u>	<u>QTY.</u>	<u>REMARKS</u>
1	1115100400	METAL KIT	1	UP TO S//N E518727; INCL. ITEMS W/#
	1115100742	METAL KIT	1	S/N E518728~
1-1	1115300400	METAL KIT, -.025MM	1	UP TO S/N E518727
	1115300742	METAL KIT, -0.25MM	1	S/N E518728~
1-2	1115400400	METAL KIT, -0.50MM	1	UP TO S/N E518727
	1115400742	METAL KIT, -0.50MM	1	S/N E518728~
2#	1116800012	METAL SET, THRUST	2	
3	5121110682	PISTON	6	UP TO MAR. 90
	1121110690	PISTON	6	APR. 90~
4	5121210050	RING SET	6	
6	912216040	PISTON PIN	6	
7	8941075750	SNAP RING	12	REPLACES 1095870480
8	5122300361	ROD ASSY.	6	UP TO JUL. 85
	1122301041	ROD ASSY.	6	AUG. 85~; INCL. ITEMS W/&
9&	5122510060	BUSHING	6	UP TO JUL 85
	1122510270	BUSHING	6	AUG. 85~
11&	5122350051	BOLT	12	UP TO JUL. 85
	1122350271	BOLT	12	AUG. 85~
13	9122716080	METAL SET, STD.	6	
13-1	9122736080	METAL SET, -0.25MM	6	
13-2	9122746080	METAL SET, -0.50MM	6	
14	1123104370	CRANKSHAFT ASSY.	1	INCL. ITEMS W/\$
17\$	9081512200	STRAIGHT PIN	1	
19	1098001560	PILOT BEARING	1	REPLACES 9000901570; UP TO DEC. 87
	1098002140	PILOT BEARING	1	JAN. 87~
26	5123310641	FLYWHEEL	1	
27	9123336070	RING GEAR, Z=129 T=22	1	
33	9920616380	BOLT	6	REPLACES 9098013340
34	5123360081	WASHER, ID=48	1	
36	5097380010	FEATHER KEY	1	
37	9125210430	CRANKSHAFT GEAR	1	
38	1123620031	THROWER	1	
60	5123712072	PULLEY	1	
67	5123620031	THROWER	1	
81	9098401071	CLAW	1	
83	9098514310	WASHER	1	

ISUZU 6BD1 — CAMSHAFT, IDLE GEAR, ROCKER ARM ASSY.

CAMSHAFT, IDLE GEAR, ROCKER ARM ASSY.

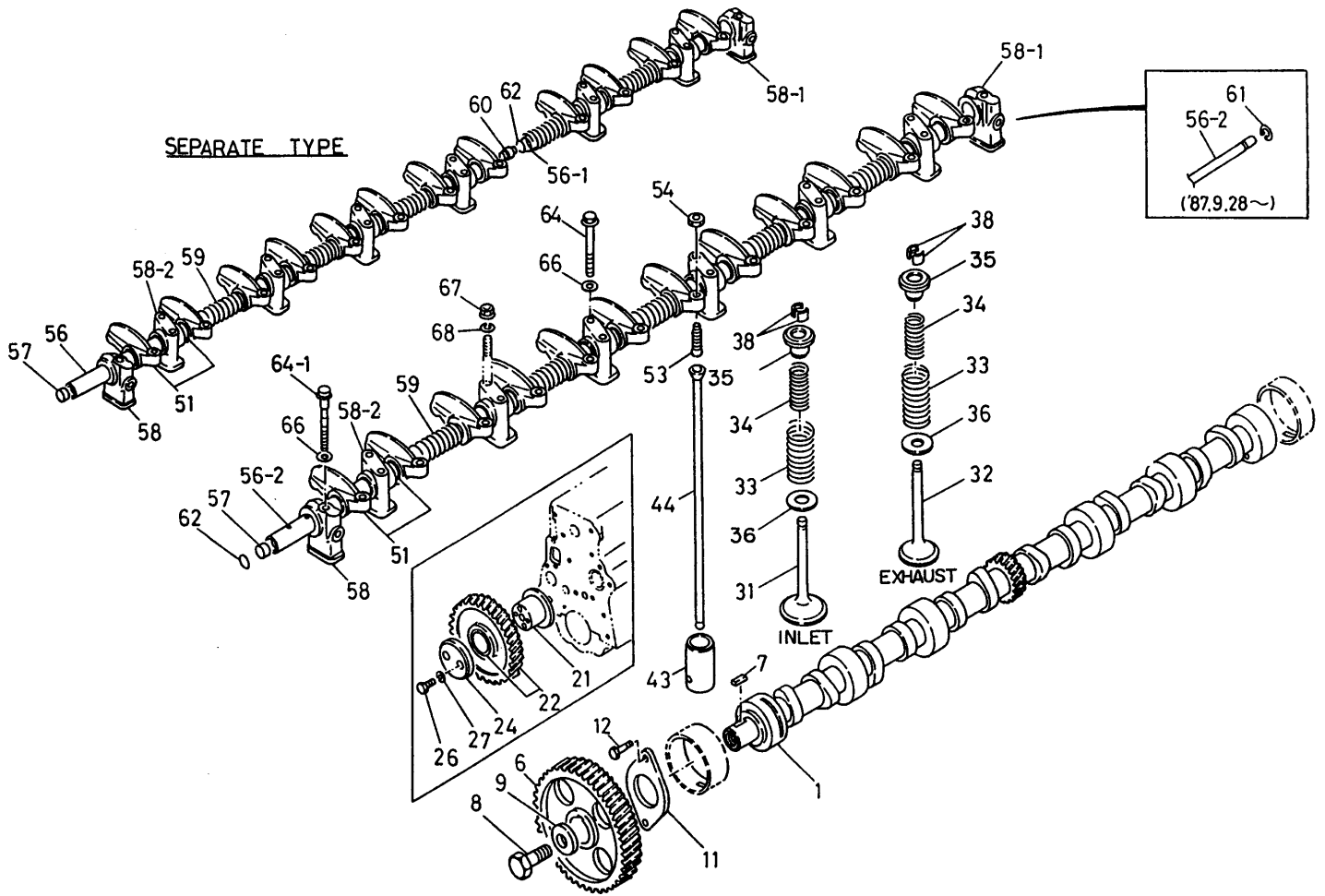

ISUZU 6BD1 — CAMSHAFT, IDLE GEAR, ROCKER ARM ASSY.

CAMSHAFT, IDLE GEAR, ROCKER ARM ASSY.

<u>NO.</u>	<u>PART NO.</u>	<u>PART NAME</u>	<u>QTY.</u>	<u>REMARKS</u>
1	9125148030	TIMING CAMSHAFT	1	
6	9125221471	GEAR, FC25	1	
7	9080307130	FEATHER KEY	1	
8	9920614280	BOLT	1	
9	9098518502	WASHER	1	
11	9116810150	THRUST PLATE	1	
12	0500408250	BOLT	2	REPLACES 9019108250
21	9125310300	IDLE GEAR SHAFT	1	
22	9125238013	GEAR	1	
24	5125350011	THRUST COLLAR	1	
26	9010510550	BOLT	2	REPLACES 9010510550
27	9091505100	LOCK WASHER	2	
31	1125510830	INLET VALVE	6	UP TO APR. 85
	1125511390	INLET VALVE	6	MAY 85~
32	1125520520	EXHAUST VALVE	6	REPLACES 1125520250
33	112561080	VALVE SPRING	12	REPLACES 5125610090
35	1125630300	UPPER VALVE SEAT	12	UP TO APR. 85
	8941145790	UPPER VALVE SEAT	12	MAY 85~
36	1125630351	LOWER VALVE SEAT	12	UP TO AUG. 88
	5125630010	LOWER VALVE SEAT	12	SEP. 88~
38	5125650060	COLLAR	24	
43	5125710032	TAPPET	12	
44	1125750360	PUSH ROD	12	
51	5126110310	ROCKER ARM	12	
53	9126160420	SCREW	12	
54	9091115080	NUT	12	
56-1	9126211301	REAR ROCKER ARM SHAFT	1	
56-2	5126200210	ROCKER ARM SHAFT	1	UP TO AUG. 87
	1126210621	ROCKER ARM SHAFT	1	SEP. 87~
57	9126260050	ROCKER ARM PLUG	2	
58	5126280112	FRONT ROCKER ARM BRACKET	1	UP TO AUG. 87
	5126280120	FRONT ROCKER ARM BRACKET	1	SEP. 87~
58-1	5126280060	REAR ROCKER ARM BRACKET	1	
58-2	9126281050	INTER ROCKER ARM BRACKET	6	
59	1095803350	ROCKER ARM SPRING	5	
60	5126230011	CONNECTOR	1	
61	9091800190	SNAP RING	1	
62	5096230600	PACKING	1	
64	9029508650	BOLT	9	UP TO AUG. 87
	1090005670	BOLT	8	SEP. 87~
64-1	9096021480	BOLT, FRONT BRACKET	1	
66	9098514300	PLAIN WASHER	10	UP TO AUG. 87
	9098514300	PLAIN WASHER	9	SEPT. 87~
67	1094001160	NUT	4	REPLACES 9091123080
68	9098514300	PLAIN WASHER	4	

ISUZU 6BD1 — OIL AND FUEL FILTER ASSY.

OIL AND FUEL FILTER ASSY.

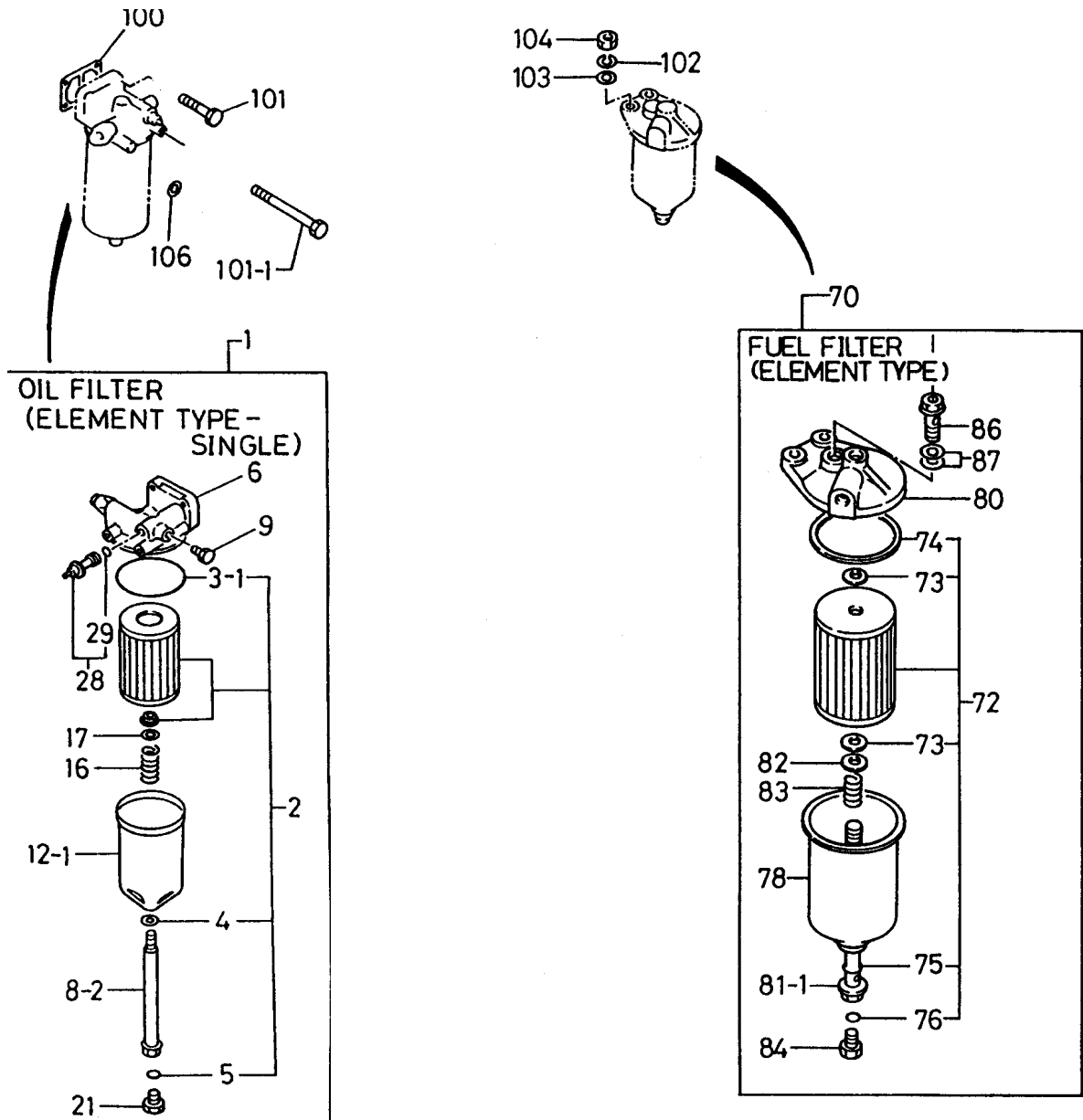

ISUZU 6BD1 — OIL AND FUEL FILTER ASSY.

OIL AND FUEL FILTER ASSY.

<u>NO.</u>	<u>PART NO.</u>	<u>PART NAME</u>	<u>QTY.</u>	<u>REMARKS</u>
1	5132000726	OIL FILTER ASSY.....	1	INCL. ITEMS W#
2#	1878100752	ELEMENT KIT	1	INCL. ITEMS W/&
3#&	9099203110	COVER PACKING	1	
4#	9099206940	CENTER BOLT PACKING	1	
5#	1096230550	O RING PACKING	1	
6#	5132120212	OIL FILTER COVER	1	
8#	1132310420	BOLT	1	
9#	9098621610	PLUG	1	
12#	5132110100	OIL FILTER CASE	1	
16#	9099412830	SPRING	1	
17#	9132390250	SPRING SEAT	1	
21#	1090001050	DRAIN PLUG	1	
28#	5132600061	OVER FLOW VALVE ASSY.	1	INCL. ITEMS W/\$
29#&	1096231630	O RING PACKING	1	
70	1132003322	FUEL FILTER ASSY.	1	INCL. ITEMS W/@
72	1878105650	ELEMENT KIT	1	REPLACES 988511911; INCL. ITEMS W/?
73@?	9097205420	PACKING	2	
71@?	9132136010	COVER BODY PACKING	1	
75@?	9097205410	O RING	1	
76@?	9099202550	DRAIN PLUG O RING	1	
78@	5132110151	FUEL FILTER CASE	1	
80@	9132128040	UPPER COVER	1	
81@	1132310330	BOLT	1	
82@	9096510680	ELEMENT SPRING SEAT	1	
83@	9097421090	ELEMENT SET SPRING	1	
84@	9098620680	DRAIN PLUG	1	
86@	1132600470	VALVE ASSY.	1	
87@	1096300850	PACKING	1	
100	1132191000	PACKING	1	UP TO OCT. 87
	1132191940	PACKING	1	NOV. 87~
101	9019710350	BOLT	2	UP TO OCT. 87
	0501410350	BOLT	2	NOV. 87~
101-1	9098009281	BOLT, L=145	2	
102	9091505100	LOCK WSAHER	2	
103	9091605100	PLAIN WASHER	2	
104	9091104100	NUT	2	
106	9095720100	OIL FILTER PACKING	2	

ISUZU 6BD1 — OIL AND AIR PIPE ASSY.

OIL AND AIR PIPE ASSY.

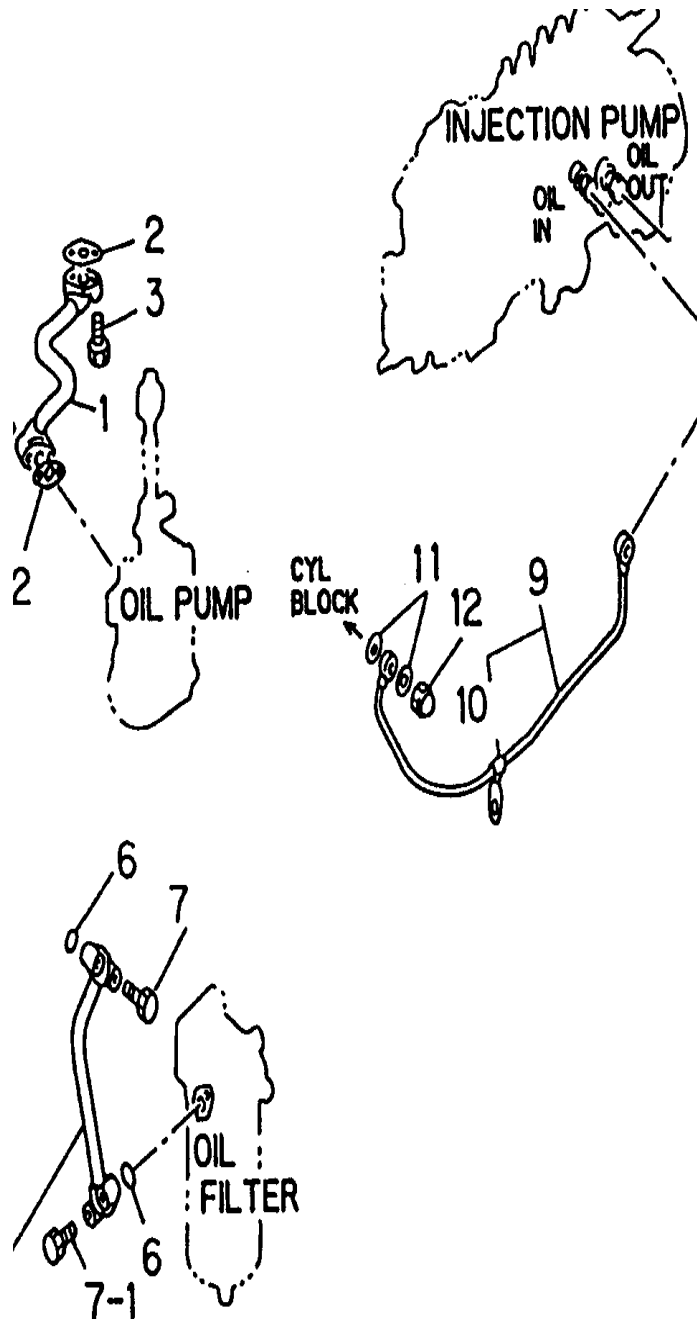

ISUZU 6BD1 — OIL AND AIR PIPE ASSY.

OIL AND AIR PIPE ASSY.

<u>NO.</u>	<u>PART NO.</u>	<u>PART NAME</u>	<u>QTY.</u>	<u>REMARKS</u>
1	5133110890	OIL PUMP ASSY.....	1	UP TO MAR. 84
	133115322	OIL PUMP ASSY.....	1	APR. 4~
2	9099211880	PACKING	2	
3	0500408400	BOLT	4	REPLACES 9019108400
4	5133111190	COOLER PIPE ASSY.	1	
6	1096232820	O RING	2	UP TO OCT. 87
	1096234620	O RING	2	NOV. 87~
7	0500408400	BOLT	4	REPLACES 9019108400
9	5133112050	OIL PIPE ASSY.....	1	INCL. ITEM W/#
10#	9099171050	CLIP	1	
11	1096308830	PACKING	2	
12	9098440220	NUT	1	

ISUZU 6BD1 — COOLING SYSTEM ASSY.

COOLING SYSTEM ASSY.

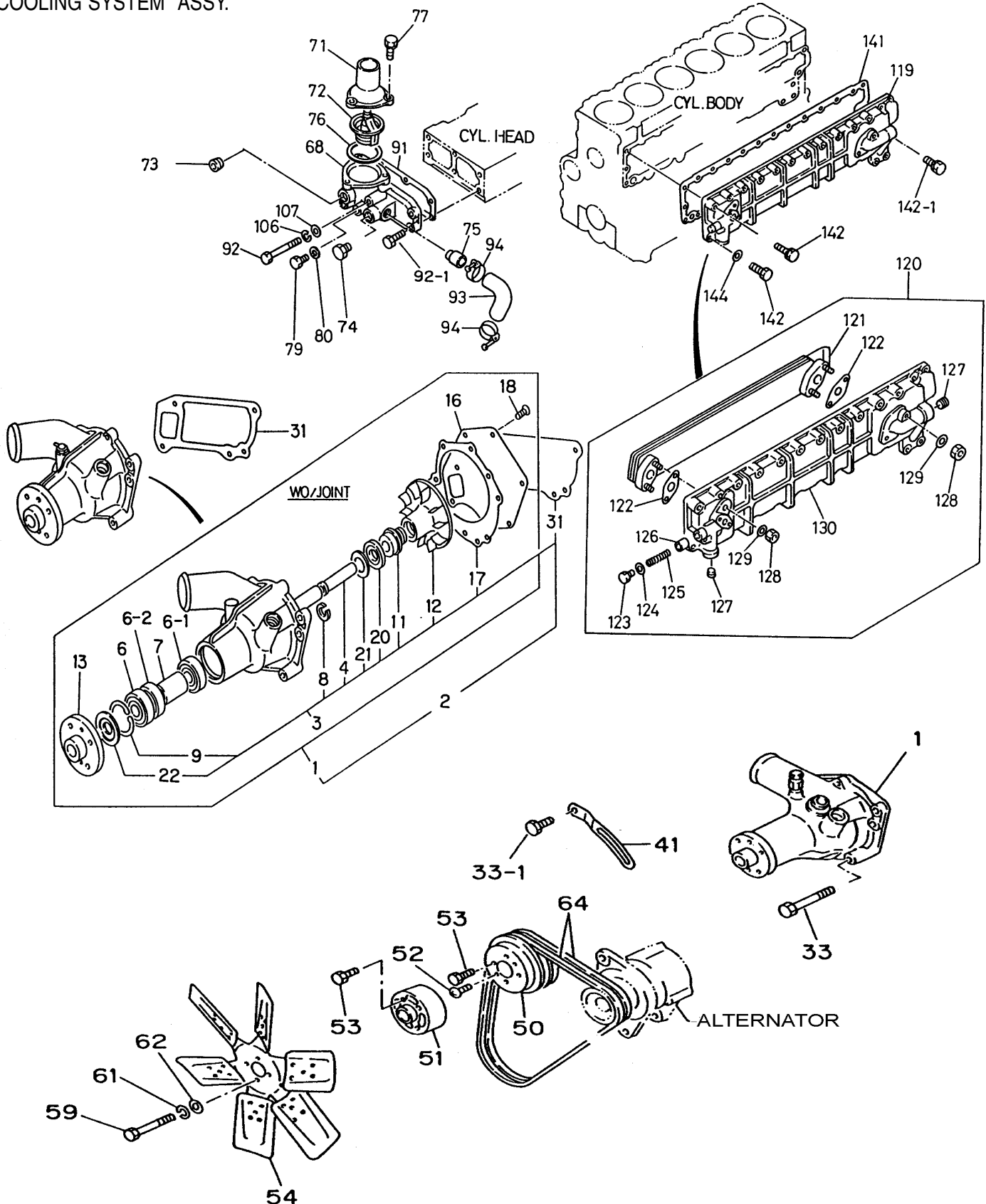

ISUZU 6BD1 — COOLING SYSTEM ASSY.

COOLING SYSTEM ASSY.

<u>NO.</u>	<u>PART NO.</u>	<u>PART NAME</u>	<u>QTY.</u>	<u>REMARKS</u>
1	5136101452	WATER PUMP ASSY	1	INCL. ITEMS W/#
2#	1136108770	PUMP KIT W/ GASKET	1	INCL. ITEMS W/%
3#%	1878102772	REPAIR KIT	1	REPLACES 5878100983
4#%	5136310090	WATER PUMP SHAFT	1	
6#%	5098000510	BALL BEARING, FRONT	1	
6-1#%	5098000500	BALL BEARING, REAR	1	
7#%	5136340020	BALL SPACKER	1	
8#%	9099521430	SNAP RING	1	
9#%	9091801520	C RING	1	
11#%	5136200061	SEAL UNIT	1	
12#%	9136218020	IMPELLER	1	
13#%	5136420072	FAN AND PULLEY CENTER	1	
16#%	9136128020	WATER PUMP COVER	1	
17#%	9136136130	PACKING	1	
18#%	9030908200	SCREW	3	
20#%	5096250550	SECONDARY SEAL	1	
21#%	1095030700	WASHER	1	
22#%	5136390010	DUST THROWER	1	
31%	1136140100	PACKING	1	UP TO OCT. 87
	1136140131	PACKING	1	NOV. 87~
33	5090300101	BOLT	1	
	0500410500	BOLT	2	REPLACES 5090000880
	0500410350	BOLT	1	REPLACES 9019110350
33-1	0500410250	BOLT	1	REPLACES 9019110250
41	9136756330	PLATE	1	
50	5136410171	PULLEY	1	
51	9136428032	SPACER	1	UP TO MAR. 87
	1136420250	SPACER	1	APR. 87~
52	9034406100	SCREW	2	
53	9019108160	BOLT	4	
54	1136600870	FAN ASSY., D=550,6,BLOWER	1	
59	1090440720	BOLT, L=65	4	
61	9091505080	LOCK WASHER	4	
62	9091647080	PLAIN WASHER	4	
64	5136710910	BELT ASSY., L=997	1	UP TO APR. 85
	5136710160	BELT ASSY., L1225	1	MAY 85 TO MAR. 87
	1136711430	BELT ASSY., L=1226	1	APR 87~
68	5137160260	THERMOSTAT HOUSING	1	
71	1137130371	THERMOSTAT JOINT	1	REPLACES 5137130161
72	5137700310	THERMOSTAT, 82-95C	1	UP TO APR. 85
	1137700700	THERMOSTAT, 85-95C	1	MAY 85~
73	9096640050	COCK PLUG	1	
74	9096620340	HEATER PLUG	1	
75	5137210152	WATER PIPE	1	

ISUZU 6BD1 — COOLING SYSTEM ASSY.

COOLING SYSTEM ASSY.

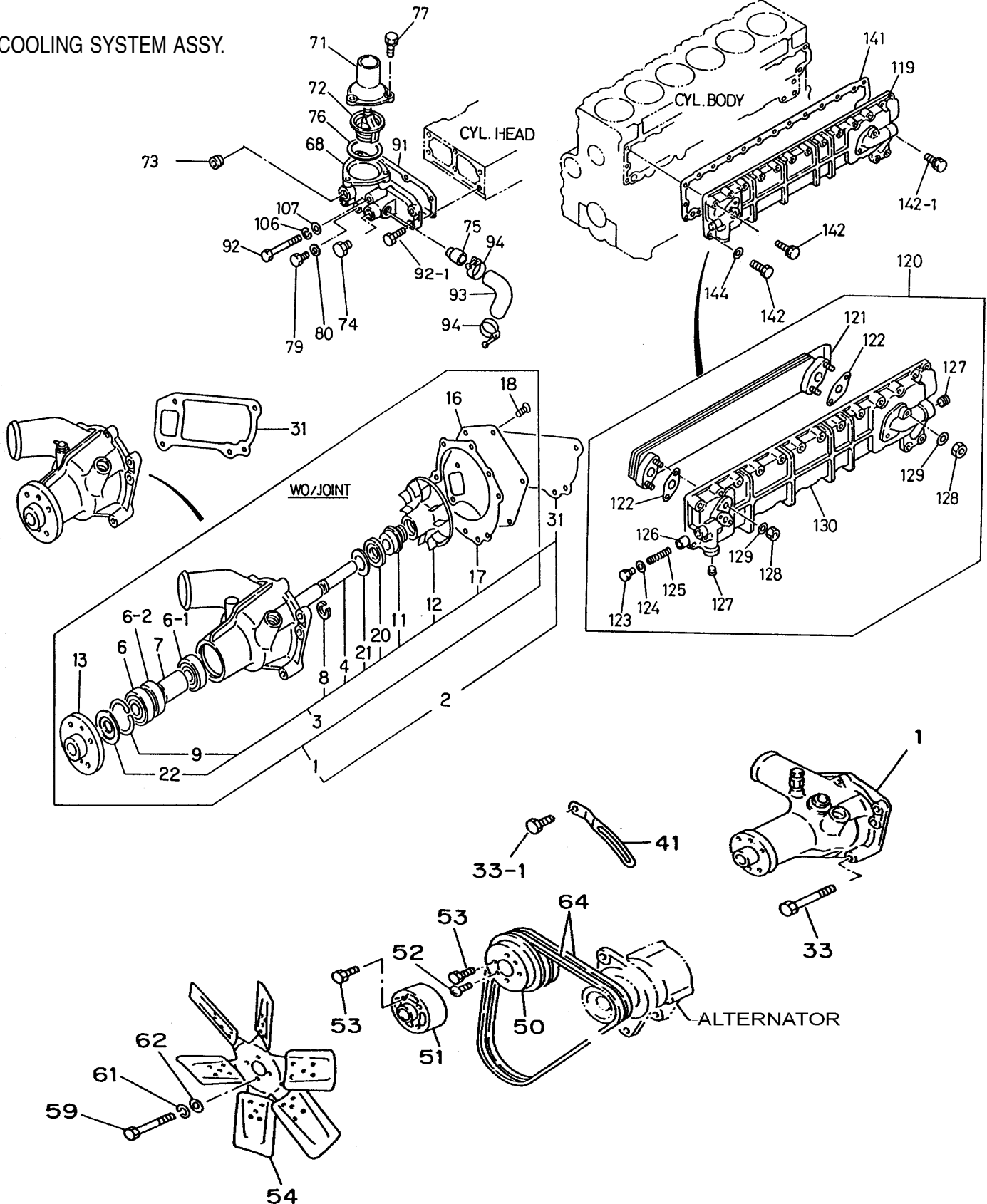

ISUZU 6BD1 — COOLING SYSTEM ASSY.

COOLING SYSTEM ASSY.

<u>NO.</u>	<u>PART NO.</u>	<u>PART NAME</u>	<u>QTY.</u>	<u>REMARKS</u>
76	9137436030	PACKING	1	UP TO APR. 86
	1137430160	PACKING	1	MAY 86~
77	0501408250	BOLT	3	REPLACES 9019708250
79	9096610050	PLUG	1	
80	9095714160	PAKING	1	
91	1137410100	PACKING	1	REPLACES 1137410080
92	0108060950	BOLT	3	REPLACES 9010560950
92-1	0501410350	BOLT	3	REPLACES 9019710350
93	5137210141	HOSE	1	
94	5097040460	CLIP	2	
106	9091505100	LOCK WASHER	3	
107	9091605100	PLAIN WASHER	3	
119	1112800051	WATER DUCT COVER	1	REPLACES 9112808016
120	5112800053	OIL COOLER ASSY.	1	INCL. ITEMS W/@
121@	5112820070	OIL COOLER ELEMENT ASSY	1	
122@	5112820060	GASKET	2	UP TO SEP. 88
	1112820140	GASKET	2	OCT. 88~
123@	9132630100	BY PASS PLUG VALVE	1	REPLACES 5096040100
124@	9095622150	PACKING	1	
125@	5095800920	SPRING	1	
126@	5112880010	BY PASS VALVE	1	
127@	5096050170	TAPER PLUG	2	
128@	9091114100	NUT	4	REPLACES 50904000280
129@	9091645100	PLAIN WASHER	4	REPLACES 5095030720
130@	5112810081	COOLER BODY	1	
141	1112820080	PACKING, COVER	1	UP TO AUG. 88
	1112820120	PACKING, COVER	1	SEP. 88~
142	8942059861	BOLT	1	
142-1	0501408280	BOLT	15	REPLACES 9019708280
	0501408200	BOLT	2	UP TO APR. 91;REPLACES 9019708200
	1090300910	BOLT	2	MAY 91~
	0501408450	BOLT	12	REPLACES 9019708450
144	9091605080	PLAIN WASHER	1	

ISUZU 6BD1 — INTAKE AND EXHAUST ASSY.

INTAKE AND EXHAUST ASSY.

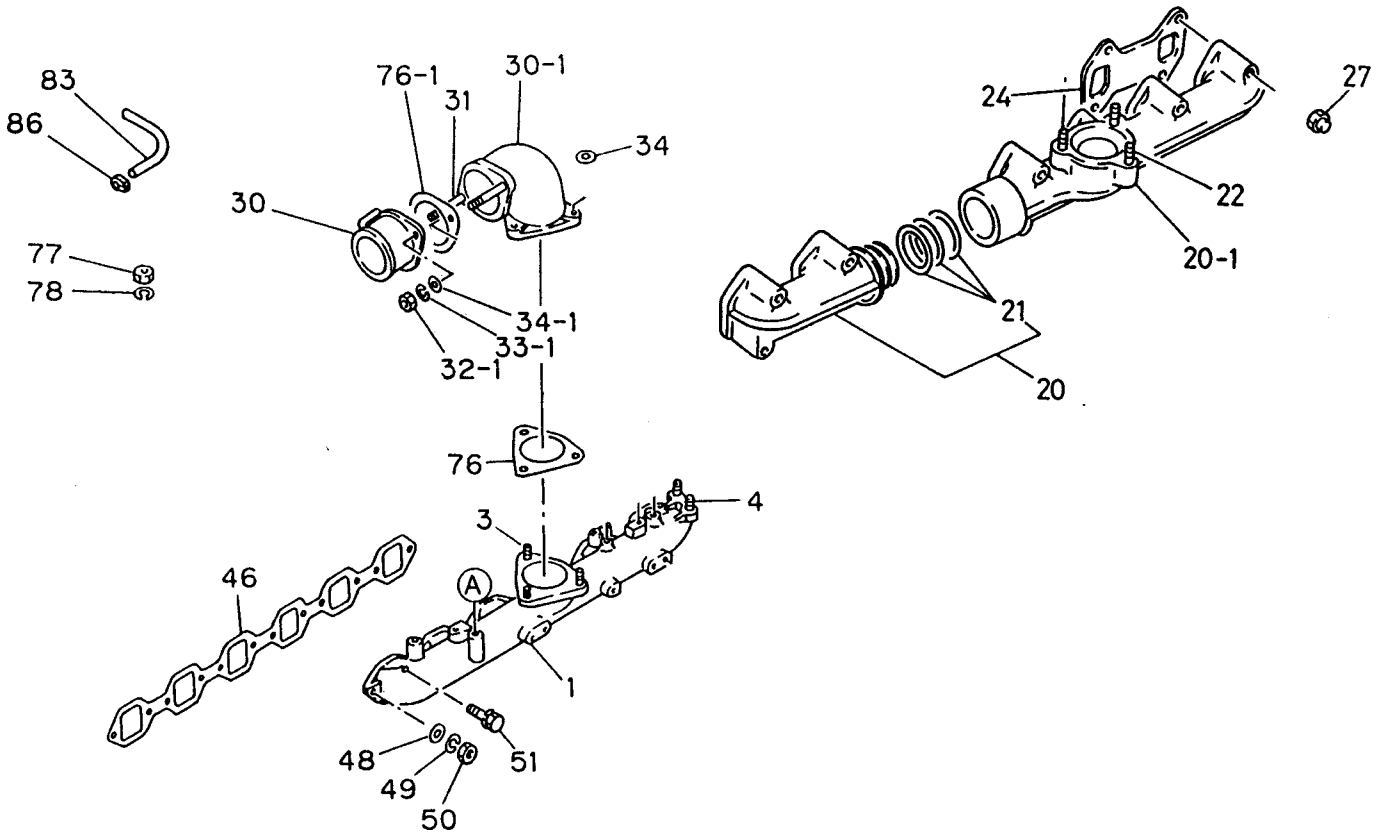

ISUZU 6BD1 — INTAKE AND EXHAUST ASSY.

INTAKE AND EXHAUST ASSY.

<u>NO.</u>	<u>PART NO.</u>	<u>PART NAME</u>	<u>QTY.</u>	<u>REMARKS</u>
1	5141112434	INLET MANIFOLD W/O STUD	1	
3	9040108280	STUD	3	
4	9044110280	FUEL FILTER STUD	2	
20	9141406130	MANIFOLD ASSY.....	1	INCL. ITEM W/#
20-1#	9141418030	MANIFOLD ASSY.	1	
21	9141496530	SEALING EXHAUST RING	3	
22	9044110300	EXHAUST STUD	3	
24	5141450040	EXHAUST GASKET	3	
27	9098445650	BUT	12	
30	5141112511	INLET PIPE	1	UP TO NOV. 88
	1141123150	INLET PIPE, H=57	1	DEC. 88~
30-1	5141111100	INLET PIPE	1	
31	9044110250	INTAKE PIPE STUD	2	
32	9091104080	NUT	3	
32-1	9091104100	NUT	2	
33	9091505080	LOCK WASHER	3	
33-1	9091505100	LOCK WASHER	2	
34	9091605080	PLAIN WASHER	3	
34-1	9091605100	PLAIN WASHER	2	
46	1141150360	INLET HEAD PACKING	1	UP TO AUG. 88
	1141150520	INLET HEAD PACKING	1	SEP. 88~
48	9091605080	PLAIN WASHER	3	
49	9091505080	LOCK WASHER	3	
50	9091104080	NUT	3	
51	9019708280	BOLT	9	UP TO APR. 90;REPLACES 9019708250
	0501408280	BOLT	9	MAY 90~
76	1141150370	INLET PACKING	1	UP TO OCT. 87
	1141150540	INLET PACKING	1	NOV. 87~
76-1	1096370560	SHUTTER PIPE PACKING	1	REPLACES 1096370470
77	9091104100	NUT	2	
78	9091505100	LOCK WASHER	2	
83	5093603200	RUBBER HOSE	1	
86	109700870	CLIP	1	

ISUZU 6BD1 — FUEL SYSTEM ASSY.

FUEL SYSTEM ASSY.

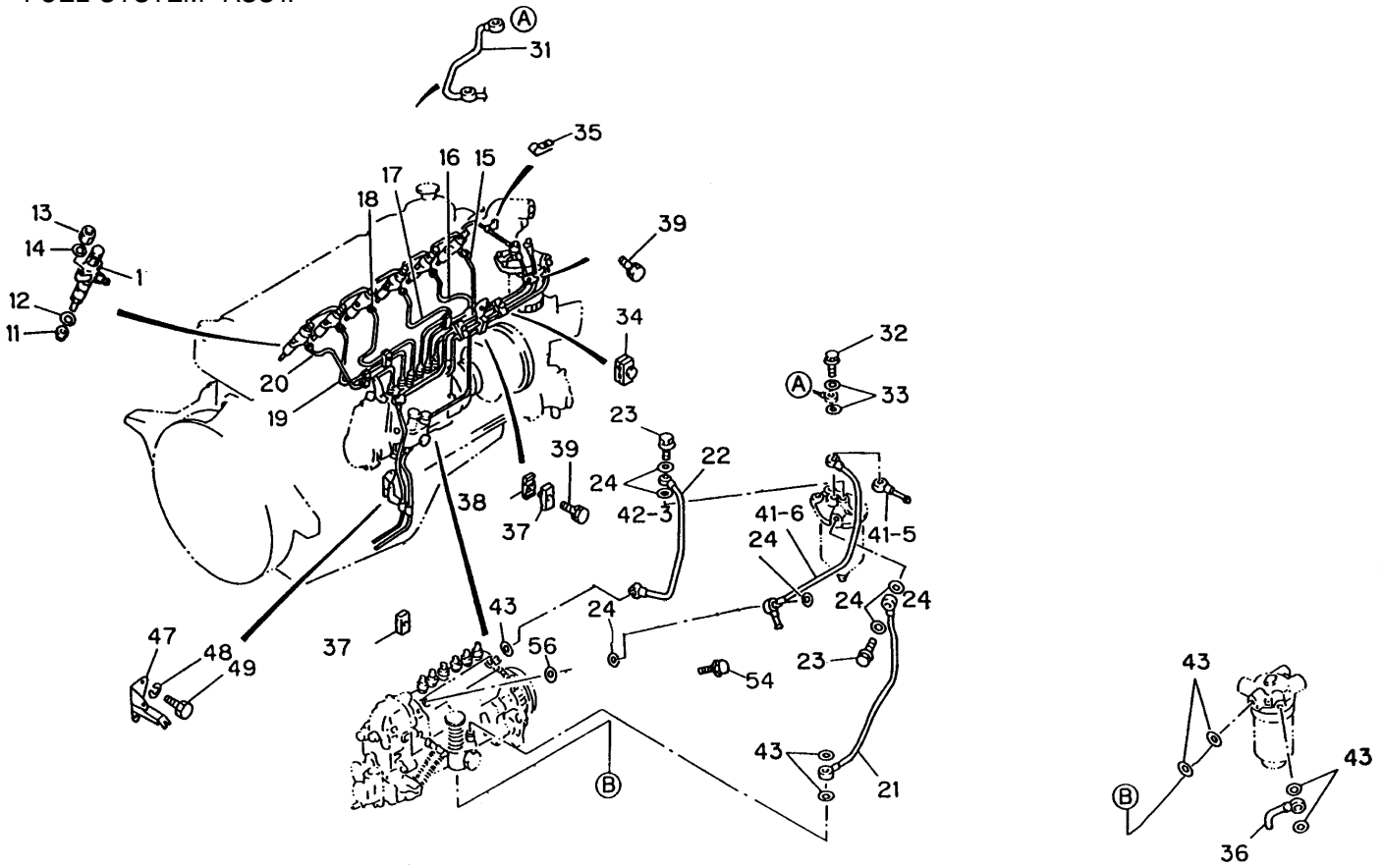

ISUZU 6BD1 — FUEL SYSTEM ASSY.

FUEL SYSTEM ASSY.

<u>NO.</u>	<u>PART NO.</u>	<u>PART NAME</u>	<u>QTY.</u>	<u>REMARKS</u>
1	5153001031	NOZZLE ASSY.	6	
11	5153150030	PACKING	6	
12	9153390510	COVER	6	
13	9091104080	NUT	12	
14	9091505080	LOCKWASHER	12	
15	5154116952	PIPE ASSY., INJ. NO. 1	1	
16	5154116962	PIPE ASSY., INJ. NO. 2	1	
17	5154116971	PIPE ASSY., INJ. NO. 3	1	UP TO MAR. 89
	1154148131	PIPE ASSY., INJ. NO. 3	1	APR. 89~
18	5154116982	PIPE ASSY., INJ. NO. 4	1	
19	5154116992	PIPE ASSY., INJ. NO. 5	1	
20	5154117002	PIPE ASSY., INJ. NO. 6	1	
21	5154115060	PIPE ASSY., FUEL PUMP FILTER	1	
22	5154115070	PIPE ASSY., INJECTION FILTER	1	
23	1096750860	BOLT	2	
24	1096300850	FUEL PIPE PACKING	6	
31	1154124711	INJECTION LEAK OFF PIPE ASSY.	1	
32	1096750371	BOLT	1	
33	9095714080	LEAK OFF PIPE PACKING	2	
34	9154196120	CLIP	6	
35	9095245550	CLIP	1	
36	5154112231	SUCTION FEED PUMP PIPE	1	
37	5097091030	CLIP	2	
38	509709104	CLIP	2	
39	9019006250	BOLT	2	
39-1	0500406300	BOLT	2	REPLACES 9019006300
41-5	5154112231	FILTER LEAK OFF PIPE ASSY.	1	
41-6	1154129180	FILTER LEAK OFF PIPE ASSY.	1	
43	1096300850	PACKING	2	
47	5197890030	BRACKET	1	
48	9091505100	LOCKWASHER	2	
49	0208010200	BOLT	2	REPLACES 9020510200
54	5132600101	OVER FLOW VALVE	1	
56	1096300850	VALVE FIXTURE PACKING	1	

ISUZU 6BD1 — ENGINE FOOT AND HANGER ASSY.

ENGINE FOOT AND HANGER ASSY.

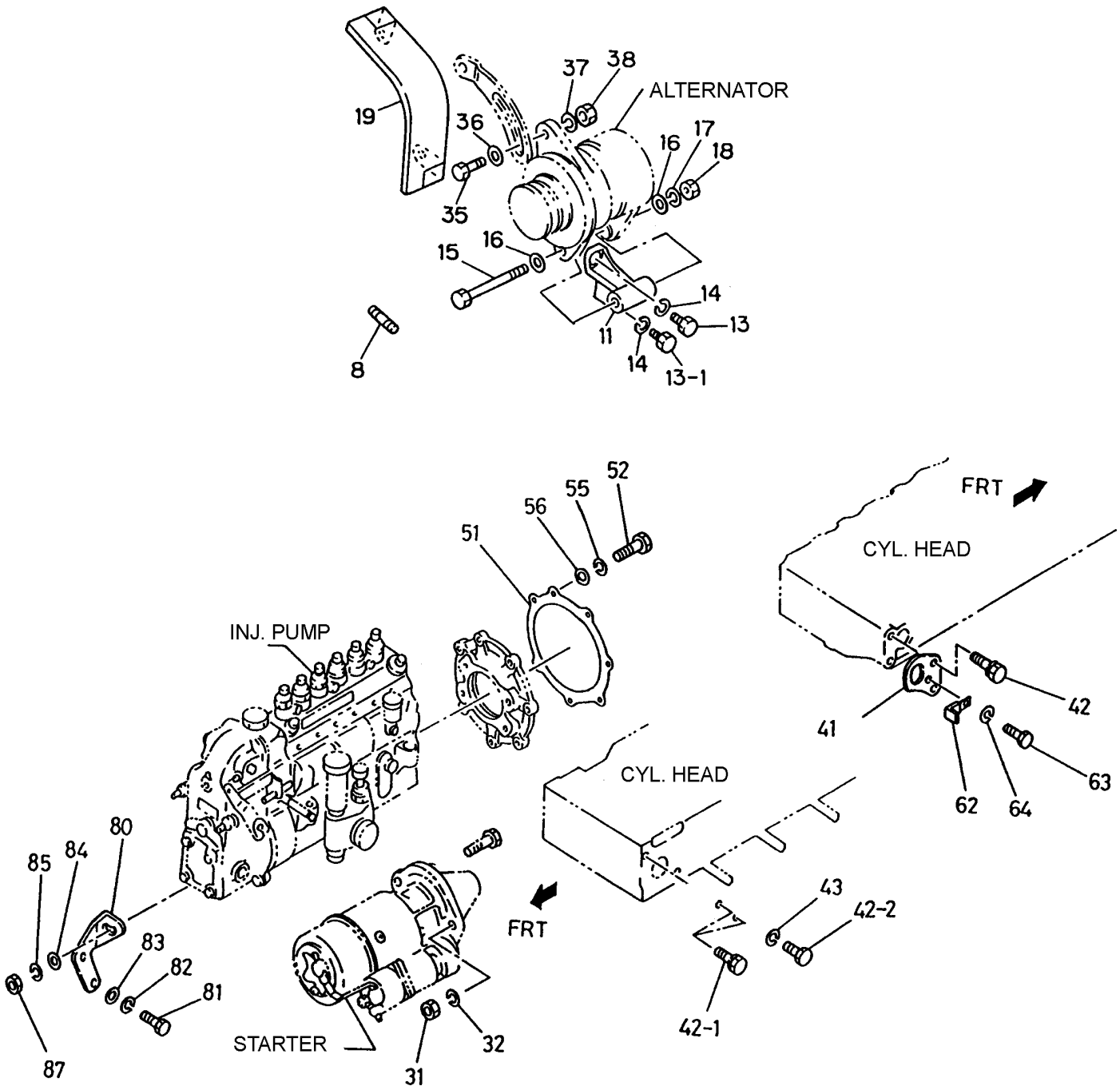

ISUZU 6BD1 — ENGINE FOOT AND HANGER ASSY.

ENGINE FOOT AND HANGER ASSY.

<u>NO.</u>	<u>PART NO.</u>	<u>PART NAME</u>	<u>QTY.</u>	<u>REMARKS</u>
8	1093000530	RIGHT FOOT STUD, L1=18.5	1	
11	5197110312	ALTERNATOR BRACKET	1	
13	0500410250	BOLT	1	REPLACES 9019110250
13-1	0500410350	BOLT	2	REPLACES 9019110350
15	1090001331	BOLT	1	
16	9091605140	PLAIN WASHER	1	
17	9091505140	LOCK WASHER	1	
18	9991104140	NUT	1	
19	1197190362	COVER	1	
31	9991104120	NUT	3	
32	9091505120	LOCK WASHER	3	
35	0208012400	BOLT	1	REPLACES 9910562400
36	9091607120	PLAIN WSAHER	1	
37	9091505120	LOCK WASHER	1	
38	9991104120	ADJUSTING NUT	1	
41	9117776221	RR. ENGINE LIFTING HANGER	1	
42	9019110200	BOLT	2	UP TO APR. 90
	9019110220	BOLT	2	MAY 90~
42-1	9019110220	BOLT	1	UP TO APR. 90
	0500410220	BOLT	1	MAY 90~
42-2	0208014250	BOLT	1	REPLACES 9920514250
43	9091504140	LOCK WASHER	1	
51	1113190080	INJECTION PUMP BRACKET ..	1	UP TO OCT. 87
	1113190090	INJECTION PUMP BRACKET ..	1	NOV. 87~
52	0108058600	BOLT	7	REPLACES 9010558600
55	9091505080	LOCK WASHER	7	
56	9091605080	PLAIN WASHER	7	
62	9099167550	CLIP	1	
63	9098008790	BOLT	1	UP TO APR. 92
	0208006100	BOLT	1	MAY 92~; REPLACES 9020406100
64	9091505060	LOCK WASHER	1	
80	5197510042	BRACKET	1	
81	9020510200	BOLT	2	UP TO SEP. 87
	0500410200	BOLT	2	OCT. 87~; REPLACES 9019110200
82	9091505100	LOCK WASHER	2	
83	9091607100	PLAIN WASHER	2	
84	9091646100	PLAIN WASHER	1	UP TO SEP. 87
	9091607100	PLAIN WASHER	1	OCT. 87~
85	9091505100	LOCK WASHER	1	
87	9091104100	NUT	1	

ISUZU 6BD1 — INJECTION PUMP ASSY.

INJECTION PUMP ASSY.

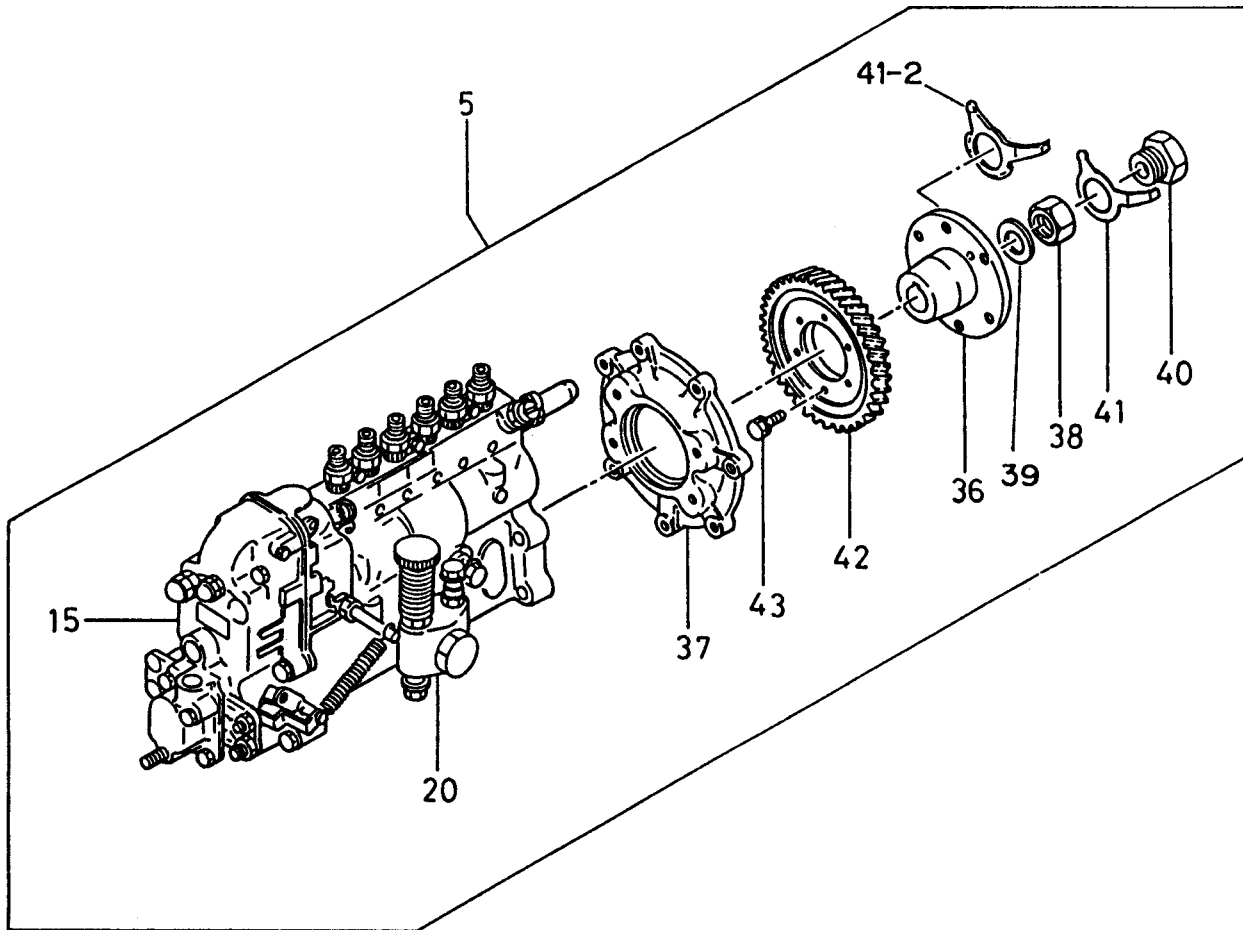

ISUZU 6BD1 — INJECTION PUMP ASSY.

INJECTION PUMP ASSY.

<u>NO.</u>	<u>PART NO.</u>	<u>PART NAME</u>	<u>QTY.</u>	<u>REMARKS</u>
5	1156020451	INJECTION PUMP ASSY.....	1	UP TO NOV. 89; REPLACES 1156010605 INCL. ITEMS W/#
	1156026800	INJECTION PUMP ASSY.....	1	DEC. 89~
15#	1157203470	GOVERNOR ASSY.....	1	UP TO NOV. 89
	1157704760	GOVERNOR ASSY.....	1	DEC. 89~
20#	1157500480	FEED PUMP ASSY.....	1	REPLACES 1157500280
36#	5157810030	INJ. PUMP COUPLING	1	
37#	1197510400	BRACKET	1	
38#	9884105020	NUT	1	
39#	5156190480	WASHER	1	
40#	9096620070	BOLT	1	
41#	1095390070	PLATE	1	REPLACES 5095390060
41-2#	1156192450	PLATE	1	
42#	5125240570	GEAR	1	
43#	9019006140	BOLT	6	

ISUZU 6BD1 — ELECTRICAL ASSY.

ELECTRICAL ASSY.

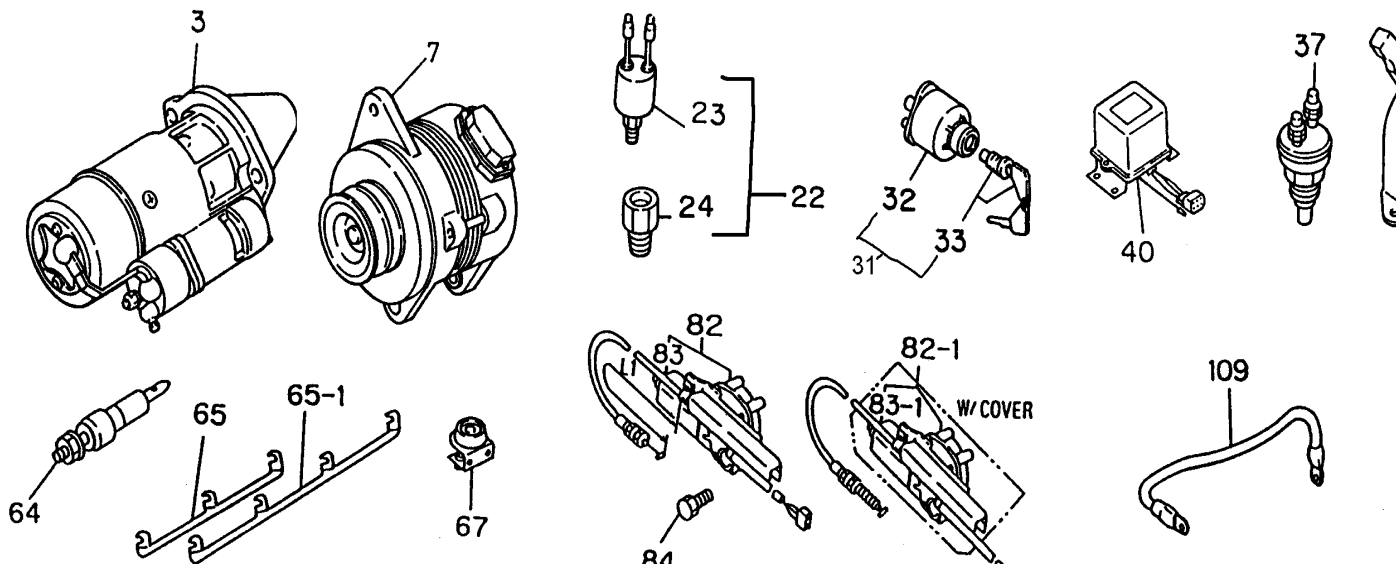

ELECTRICAL ASSY.

<u>NO.</u>	<u>PART NO.</u>	<u>PART NAME</u>	<u>QTY.</u>	<u>REMARKS</u>
3	1811001910	STARTER	1	
7	1812002050	ALTERNATOR	1	
22	5831510030	OIL PRESSURE SWITCH ADAPTER ...	1 INCL. ITEMS W/#
23#	9827200690	OIL PRESSURE WARNING SW.	1	
24#	9099022380	ADAPTER	1	
29	9831514320	THERMOMETER, OIL	1	
30	1823200010	BATTERY SW. ASSY.....	1 REPLACES 9827300090
31	1823100080	STARTER SWITCH ASSY.....	1 INCL. ITEMS W/&
32&	1823130030	STARTER SWITCH	1	
33&	1823170070	LOCK WITH KEY BARREL	1	
37	5824500141	OVER HEAT SW.	1	
40	1825500732	EMERGENCY RELAY	1	
64	9825139288	GLOW PLUG, 20.5V	6	
65	5197320010	GLOW PLUG CONNECTOR	1	
65-1	5197320020	GLOW PLUG CONNECTOR	1	
67	9825300430	RESISTANCE CONTROL, 24V	1	
82	1819000161	ENGINE STOPPER ASSY.	1 INCL. ITEM W/%
82-1	1819001931	ENGINE STOPPER ASSY. W/COVER	1	
83%	1828490430	CABLE ASSY., L=460	1	
109	9829322110	STARTER-FRAME CABLE ASSY.	1	

ISUZU 6BD1 — INJ. PUMP COMP. ASSY.

INJECTION PUMP COMP. ASSY.

<u>NO.</u>	<u>PART NO.</u>	<u>PART NAME</u>	<u>QTY.</u>	<u>REMARKS</u>
5	1156110750	HOUSING ASSY.	1	
14	5156190440	ADAPTER	1	
15	9812151150	STUD	3	
16	9812350170	ADAPTER	1	
18	1156190240	BOLT	3	
20	8941445880	GASKET	1	
22	1156290500	COVER	1	
23	1156190030	SCREW	2	
24	9812151440	GASEKT	2	
27	9091505060	WAWSHER	3	
28	1157290060	NUT	3	
29	1096230130	O RING	1	
31	5156310070	PLUNGER ASSY.	6	
32	1156410160	DELIVERY VALVE ASSY.	6	
34	515630010	SPRING	6	
35	1156490010	GASKET	6	
36	5156440100	HOLDER	6	
40	5156250010	PLATE ASSY	3	
41	1096230520	O RING	3	
43	9812212230	TAPPET ASSY.	6.....	INCL. ITEMS W/#
45#	9812212200	PIN	6	
47#	1156220030	ROLLER	6	
48#	1156290010	BUSHING	6	
49#	5156190410	GUIDE	6	
55	5156190010	SHIM, T=+0.60		
	5156190020	SHIM, T=+0.70		
	5156190030	SHIM, T=+0.80		
	5156190040	SHIM, T=+0.90		
	5156190050	SHIM, T=+1.00		
	5156190070	SHIM, T=+1.10		
	5156190080	SHIM, T=+1.20		
	5156190090	SHIM, T=+1.30		
	5156191080	SHIM, T=+1.35		
	5156190100	SHIM, T=+1.40		
	5156191090	SHIM, T=+1.45		
	5156191060	SHIM, T=+1.50		
	5156191100	SHIM, T=+1.55		
	5156191070	SHIM, T=+1.60		
	5156190110	SHIM, T=+0.55		
	5156190120	SHIM, T=+0.65		
	5156190130	SHIM, T=+0.75		
	5156190150	SHIM, T=+0.85		
	5156190250	SHIM, T=+0.20		
	5156190260	SHIM, T=+0.25		

ISUZU 6BD1 — INJ. PUMP COMP. ASSY.

INJECTION PUMP COMP. ASSY.

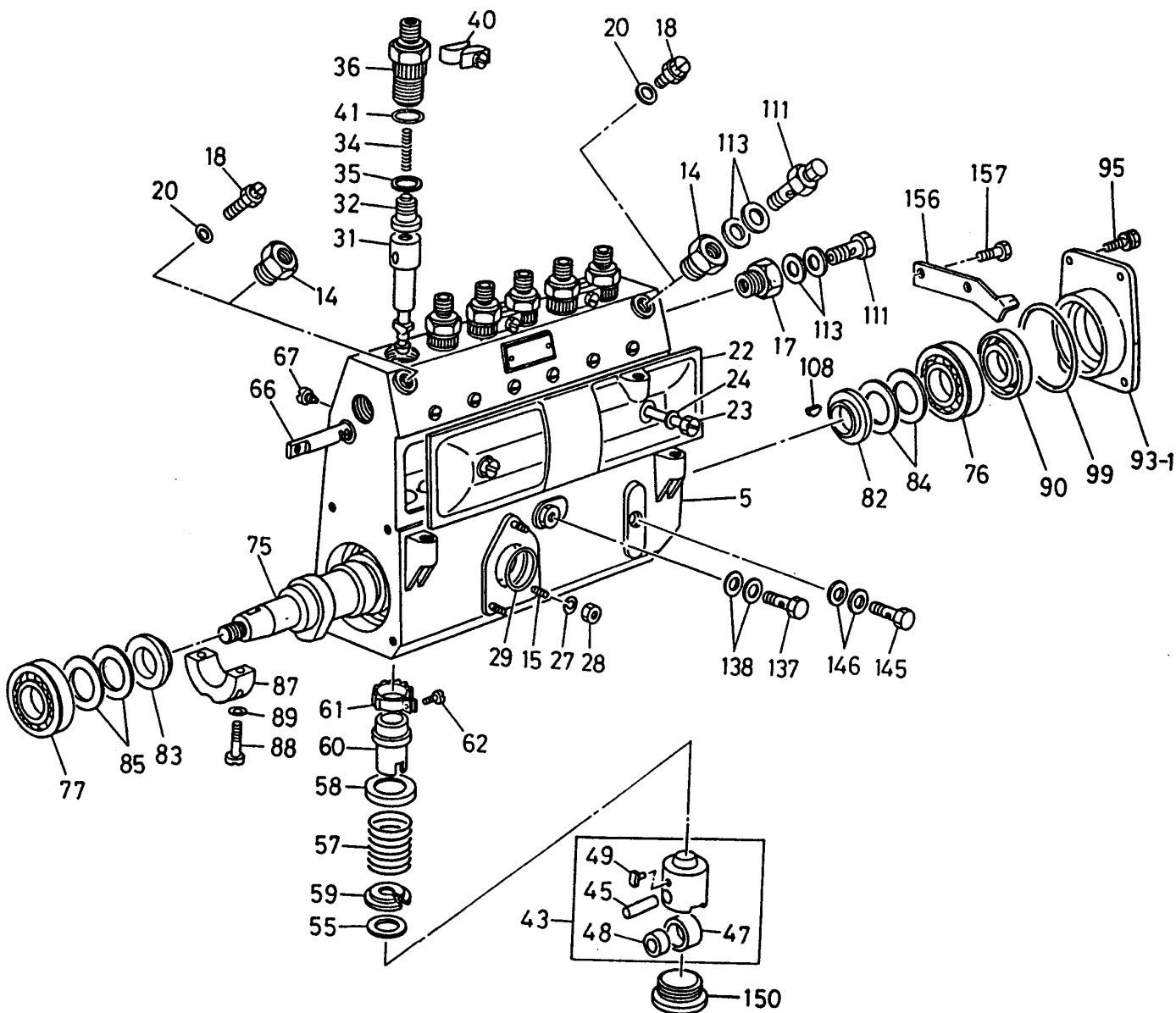

ISUZU 6BD1 — INJ. PUMP COMP. ASSY.

INJECTION PUMP COMP. ASSY.

<u>NO.</u>	<u>PART NO.</u>	<u>PART NAME</u>	<u>QTY.</u>	<u>REMARKS</u>
	5156190270	SHIM, T=+0.35		
	5156190340	SHIM, T=+0.30		
	5156190350	SHIM, T=+0.40		
	5156190360	SHIM, T=+0.50		
	5156190370	SHIM, T=+0.45		
	9812350420	SHIM, T=+0.95		
	9812350430	SHIM, T=+1.05		
	9812350440	SHIM, T=+1.15		
	9812350450	SHIM, T=+1.25		
	5156430090	SPRING	6	
58	9812350150	SEAT	6	
59	9812350210	SEAT	6	
60	9812250580	SLEEVE	6	
61	9812250570	PINION	6	
62	9812350030	SCREW	6	
66	5156370030	RACK	1	
67	1156390030	SCREW	1	
75-3	1156210630	CAMSHAFT	1	
75-4	1156210630	CAMSHAFT	1	
76	1156290020	BALL BEARING, OVERSIZE	AR	
	1156290030	BALL BEARING, STD	AR	
77	5098000380	BALL BEARING, OVERSIZE	AR	
	9000906770	BALL BEARING, STD	AR	
82	5156290240	RING	1	
83	9812250470	RING	1	
84	9812250490	SHIM, T=+0.10		
	9812250500	SHIM, T=+0.12		
	9812250510	SHIM, T=+0.14		
	9812250520	SHIM, T=+0.16		
	9812250530	SHIM, T=+0.18		
	9812250540	SHIM, T=+0.50		
	1156290070	SHIM, T=+1.00		
	5156190380	SHIM, T=1.00		
	5156190390	SHIM, T=+0.70		
	1156190900	SHIM, T=+1.40		
	5156290150	SHIM, T=+0.10		
	5156290160	SHIM, T=+0.12		
	5156290170	SHIM, T=+0.14		
	5156290180	SHIM, T=+0.16		
	51562901190	SHIM, T=+0.18		
	5156290200	SHIM, T=+0.50		
	5156290210	SHIM, T=+0.30		

ISUZU 6BD1 — INJ. PUMP COMP. ASSY.

INJECTION PUMP COMP. ASSY.

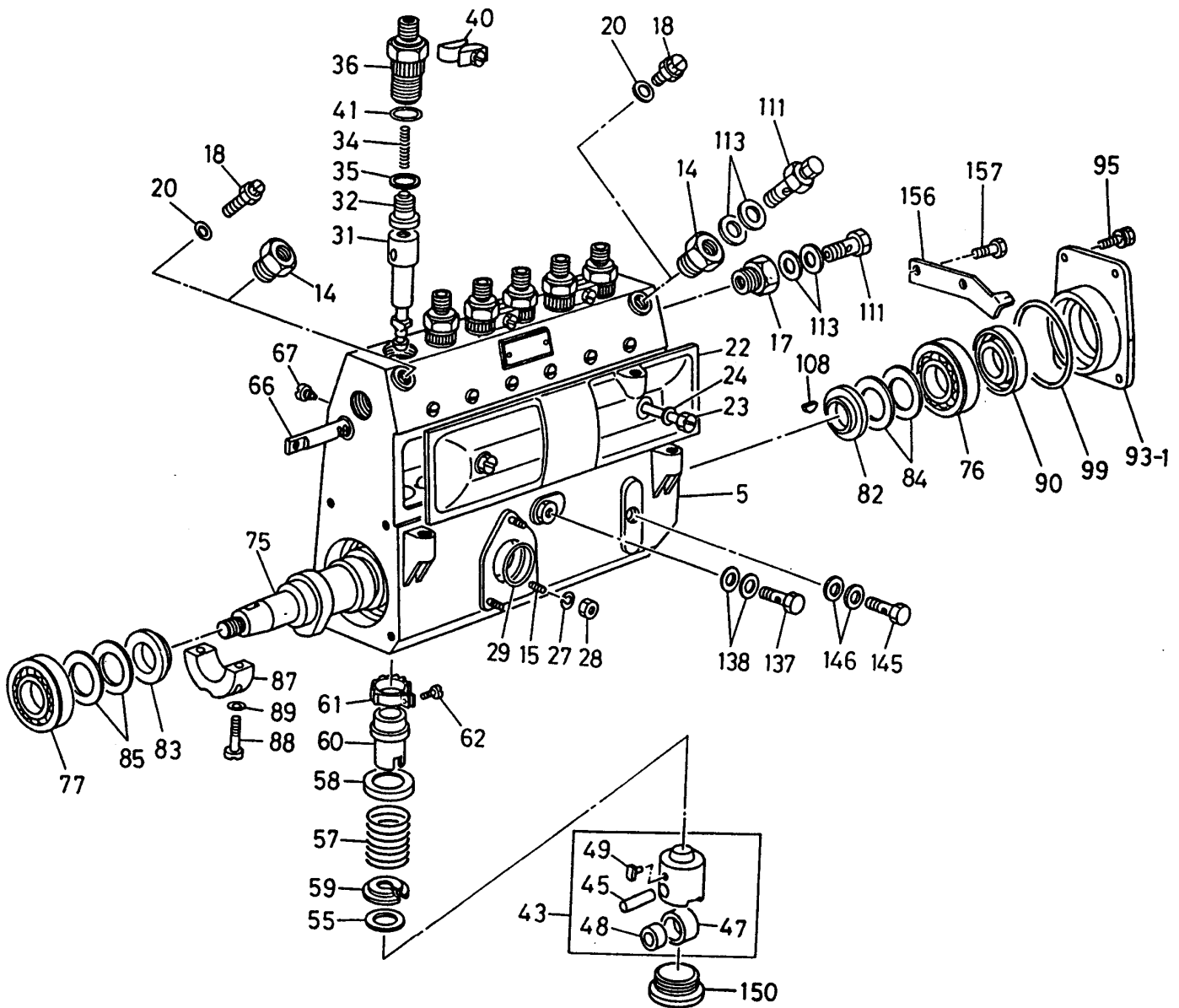

INJECTION PUMP COMP. ASSY.

<u>NO.</u>	<u>PART NO.</u>	<u>PART NAME</u>	<u>QTY.</u>	<u>REMARKS</u>
87	1156190330	BEARING	1	
88	9884100660	SCREW	2	
89	9812250430	WASHER	2	
93	1156290470	COVER	1	
95	1156192820	BOLT	4	
108	5835390240	WOODRUFF KEY	1	
150	5156191360	PLUB	6	
162	9091606100	WASHER	4	
163	9091506100	WASHER	4	
164	5156390020	NUT	4	
180	1156192660	BRACKET	1	
181	1156290490	PACKING	1	
182	9041010300	STUD	4	
183	1156290480	GASKET	1	

ISUZU 6BD1 — GOVERNOR COMP. ASSY.

GOVERNOR COMP. ASSY.

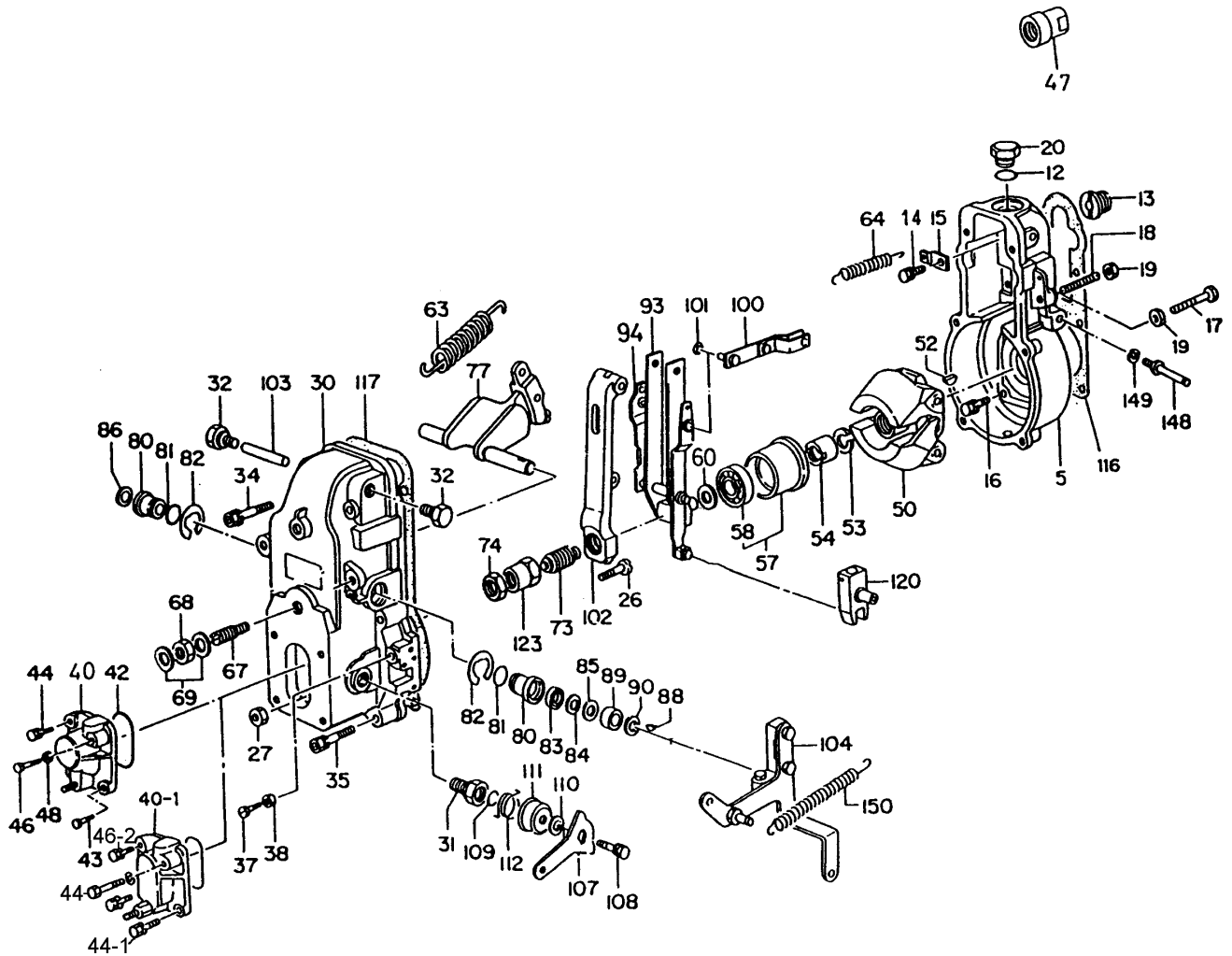

ISUZU 6BD1 — GOVERNOR COMP. ASSY.

GOVERNOR COMP. ASSY.

<u>NO.</u>	<u>PART NO.</u>	<u>PART NAME</u>	<u>QTY.</u>	<u>REMARKS</u>
5	5157210040	HOUSING	1	INCL. ITEMS W/#
12#	1157290150	O RING	1	
13#	9813150650	ADAPTER	1	
14#	9019008180	BOLT	1	
15#	9813253970	PLATE	1	
16#	9019006140	BOLT	6	
18#	5157291230	SCREW	1	
19#	9813252370	NUT	2	
50#	1157290380	PLUG	1	
26#	9813251820	SCREW	1	
27#	9813261120	NUT	1	
30#	5157210200	COVER	1	
31#	9813254290	BUSHING	1	
32#	5157290530	PLUG	2	
34#	5157290540	BOLT	2	
35#	5157290330	BOLT	4	
36#	9813251770	SCRWE	1	
37#	5157291020	BLT	1	
38#	9884100270	NUT	1	
40#	5157210210	COVER	1	
42#	9813919070	O RING	1	
44#	9019006160	BOLT	3	
46#	1157290280	BOLT	1	
47#	9812350340	CAP	1	
48#	9091505060	LOCK WASHER	1	
50#	5157220080	FLYWEIGHT ASSY.	1	
52#	5156190490	KEY	1	
53#	5157290340	LOCK WASHER	1	
54#	9813250860	NUT	1	
57#	5157190080	SLEEVE	1	
58#	9000902290	BEARING	1	
60#	9813250880	SHIM, T=0.20		
	9813255510	SHIM, T=+0.30		
	9813255520	SHIM, T=+0.40		
	9813255530	SHIM, T=+1.00		
	5157292860	SHIM, T=+0.50		
	5157292870	SHIM, T=+0.50		
63#	9008121300	SPRING	1	
64#	9813222350	SPRING	1	
67#	5157231240	CAPSULE	1	
68#	5157292090	NUT	1	
69#	1156390080	GASKET	2	
73#	5157230990	CAPSULE	1	
74#	9008130230	NUT	1	
77#	9813217210	LEVER	1	
80#	1157292930	BUSH	2	
81#	9813212050	O RING	2	
82#	9091854150	SNAP RING	2	

ISUZU 6BD1 — GOVERNOR COMP. ASSY.

GOVERNOR COMP. ASSY.

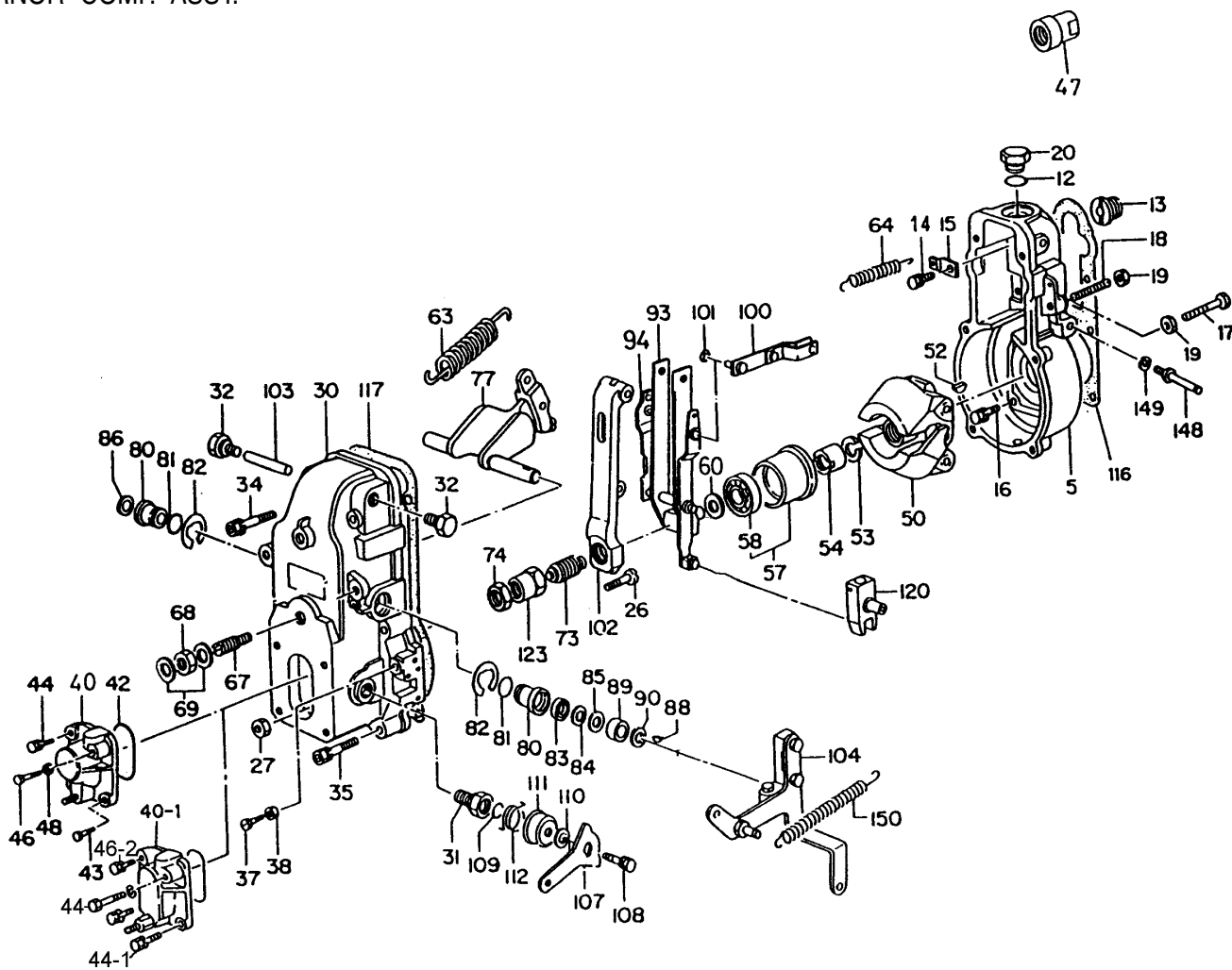

ISUZU 6BD1 — GOVERNOR COMP. ASSY.

GOVERNOR COMP. ASSY.

<u>NO.</u>	<u>PART NO.</u>	<u>PART NAME</u>	<u>QTY.</u>	<u>REMARKS</u>
83#	1157290980	OIL SEAL	1	
84#	1157290990	SHIM	1	
85#	9813250970	SHIM, T=0.30		
86#	9813253180	PLUG	1	
89#	1157293010	COLLAR	1	
90#	9813254880	WASHER		
93#	5157250570	LEVER	1	
100#	1157250110	LINK	1	
101#	9091854040	SNAP RING	1	
102#	5157250170	LEVER	1	
103#	9813250620	PIN	1	
104#	5157250410	LEVER	1	
107#	5157250810	LEVER	1	
108#	9019006160	BOLT	1	
109#	9813919060	O RING	1	
110#	1157292990	SHIM, T=0.50		
	1157292980	SHIM, T=+0.50		
	1157292980	SHIM, T=+0.40		
	1157292970	SHIM, T=+3.35		
	1157292960	SHIM, T=+0.30		
	1157292950	SHIM, T=+0.25		
	1157292940	SHIM, T=+0.20		
111#	9813252100	CAP	1	
112#	5157230640	SPRING	1	
116#	1157290010	GASKET	1	
117#	1157290020	GASKET	1	
120#	5157250420	LEVER ASSY.	1	
148#	5157291120	BOLT	1	
149#	9091505080	LOCK WASHER	1	
150#	5157230880	SPRING	1	

ISUZU 6BD1 —FEED PUMP ASSY.

FEED PUMP ASSY.

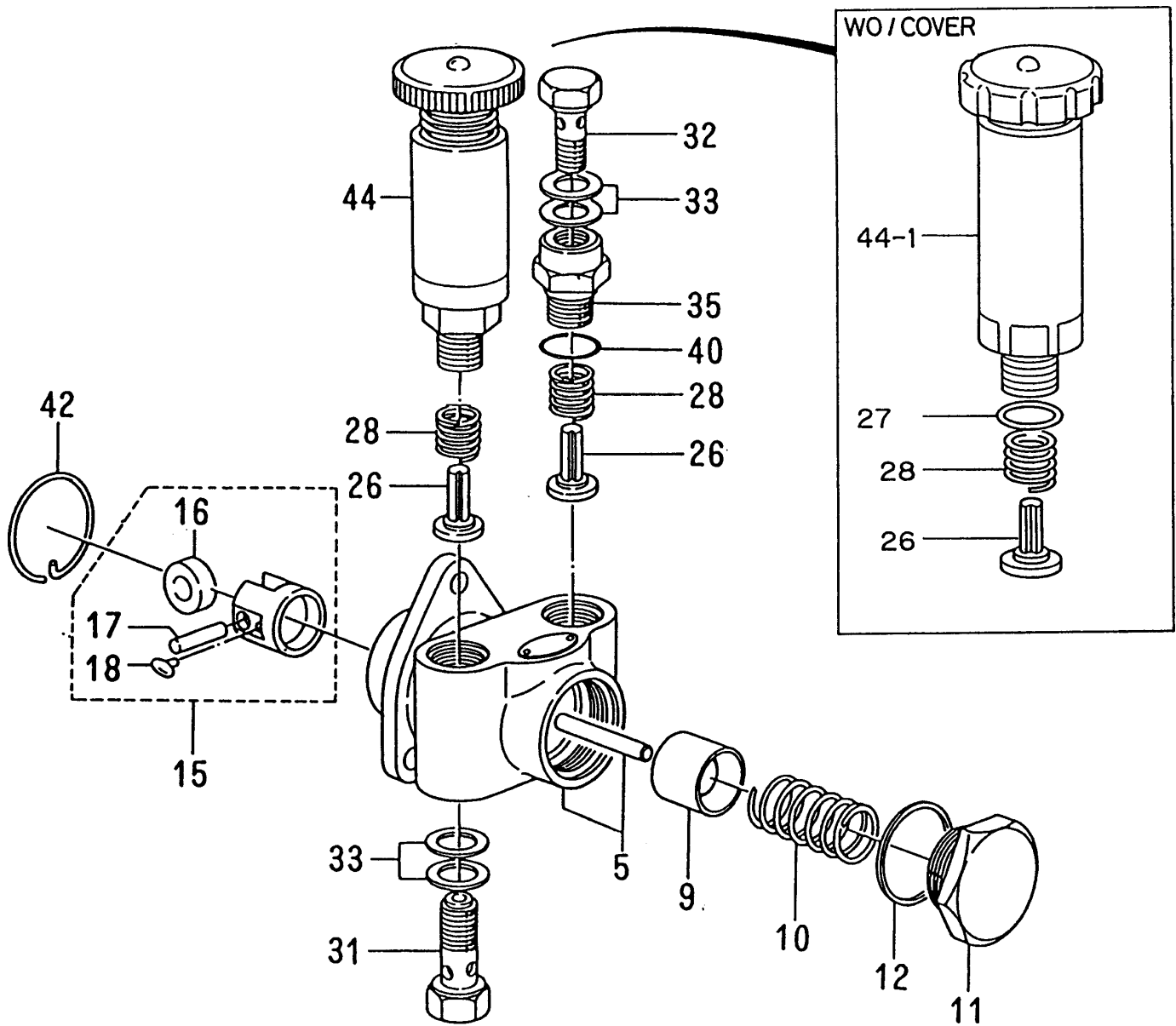

ISUZU 6BD1 — FEED PUMP ASSY.

FEED PUMP ASSY.

<u>NO.</u>	<u>PART NO.</u>	<u>PART NAME</u>	<u>QTY.</u>	<u>REMARKS</u>
	1157500480	FEED PUMP ASSY.	1	INCL. ITEMS W#
5#	5157510120	HOUSING	1	
9#	9813512050	PISTON	1	
10#	9813513020	SPRING	1	
11#	9813550230	PLUG	1	
12#	9813550350	GASKET	1	
15#	5157540010	TAPPET ASSY.	1	INCL. ITEMS W/%
16#%	9813514030	ROLLER	1	
17#%	9813514100	PIN	1	
18#%	1157590020	GUIDE	2	
26#	9813516020	VALVE	2	
27#	1196230160	O RING	1	REPLACES 1096230160
28#	9813517020	SPRING	2	
31#	1096750630	BOLT	1	
32#	1157590110	BOLT	1	
33#	1157590120	PACKING	4	
35#	1157590030	ADAPTER	1	
40#	1196230160	O RING	1	REPLACES 1096230160
42#	9813550250	SNAP RING	1	
44#	8941311300	PUMP	1	

NOZZLE ASSY.

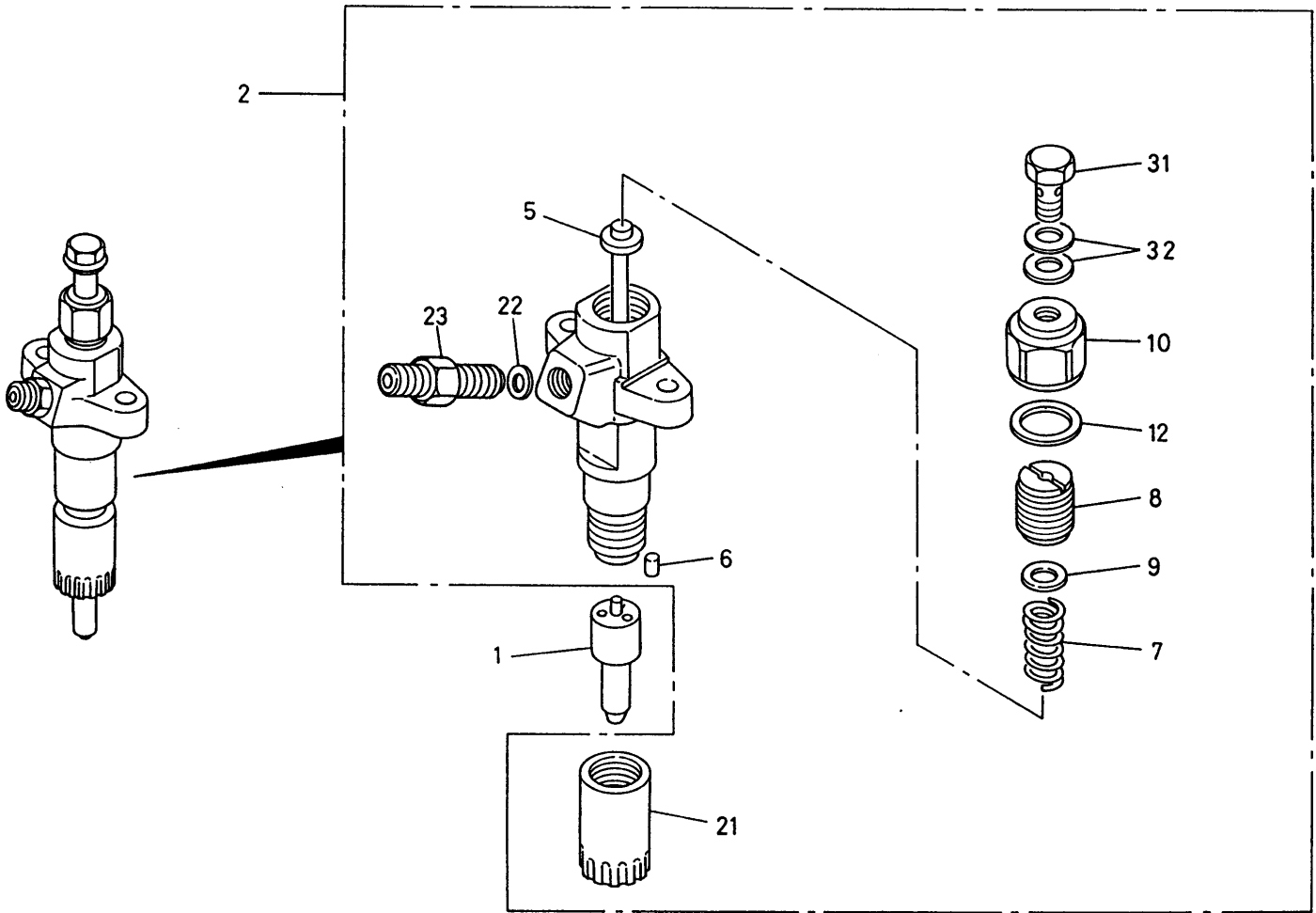

NOZZLE ASSY.

<u>NO.</u>	<u>PART NO.</u>	<u>PART NAME</u>	<u>QTY.</u>	<u>REMARKS</u>
1	5153110191	NOZZLE ASSY.	6	REPLACES 5153110190
2	5153300191	HOLDER ASSY.	6	REPLACES 5153300190; INCL. ITEMS W/#
5#	5153410010	PUSH ROD	6	
6#	9153470030	PIN	12	
7#	9153430130	SPRING	6	
8#	5153450010	SCREW	6	
9#	9153390570	WASHE	6	
10#	5153340010	NUT	6	
12#	9153390560	GASKET	6	
21#	5153320020	NUT	6	
22#	5153390030	GASKET	6	
23#	5153490020	CONNECTOR	6	
31#	5153490010	BOLT	6	
32#	9095714080	PAKCING, T=1.0	12	

ISUZU 6BD1 — STARTER ASSY,

STARTER ASSY.

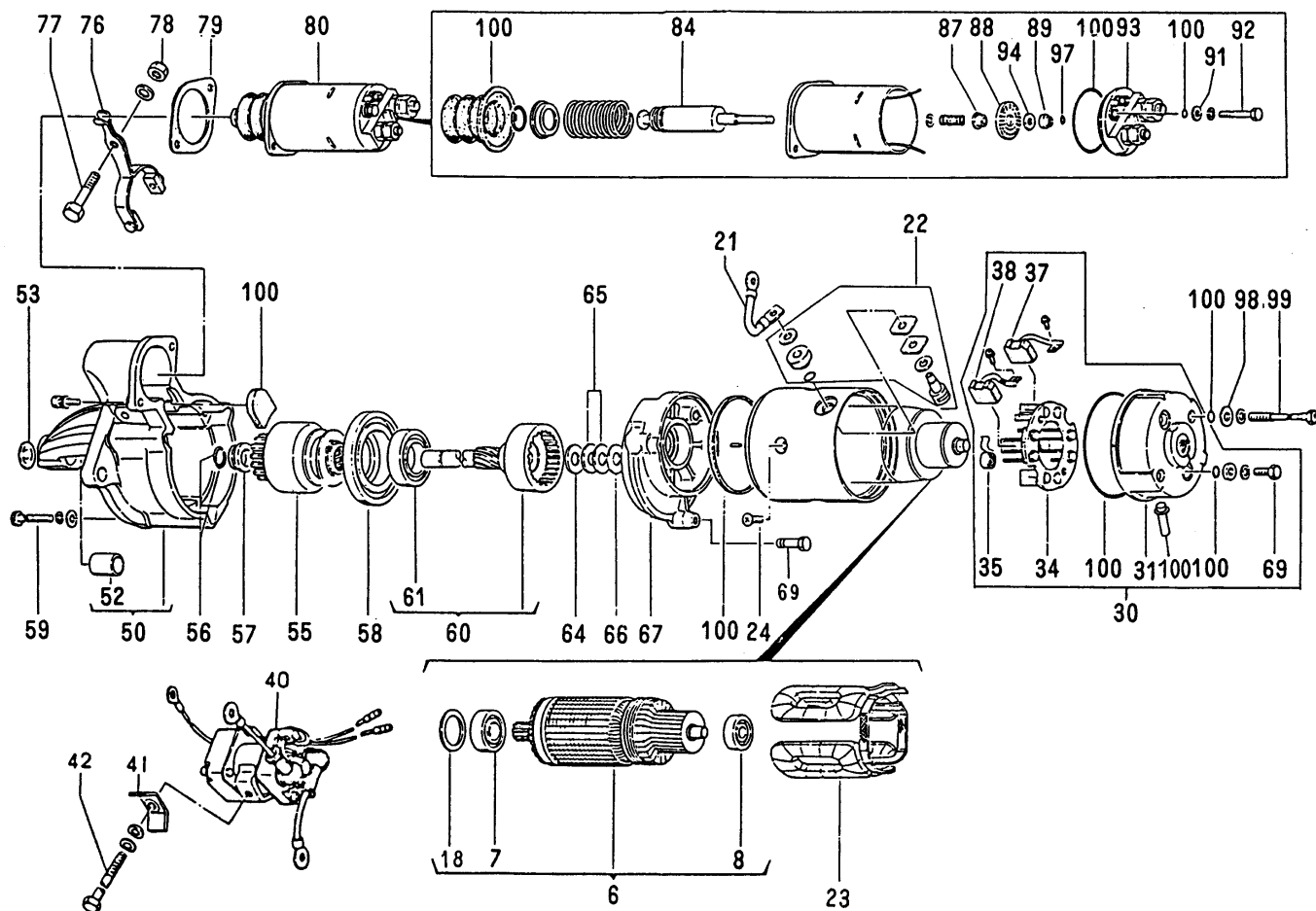

STARTER ASSY.

<u>NO.</u>	<u>PART NO.</u>	<u>PART NAME</u>	<u>QTY.</u>	<u>REMARKS</u>
	1811001910	STARTER ASSY.	1	INCL. ITEMS W/#
6#	1811210370	ARMATURE ASSY.	1	
7#	1811293950	BALL BEARING	1	
8#	1811293850	BALL BEARING	1	
18#	5811291560	WASHER	2	
21#	1811160440	LEAD WIRE	1	
22#	1811293840	TERMINAL	1	
23#	1811293960	FIELD COIL	1	
24#	5811292210	SCREW	4	
30#	1811150610	COVER	1	INCL. ITEMS W/@
31#@	1811150620	REAR COVER	1	
34#@	1811180360	BRUSH HOLDER	1	
35#@	1811170140	BRUSH SPRNG	4	
37#@	1811160430	BRUSH, (-)	2	
38#@	1811160420	BRUSH, (+)	2	
40#	1825530230	RELAY SAFETY SWITCH	1	
41#	1811180390	HOLDER	1	
42#	1811294010	BOLT	1	
50#	1811230250	FRONT COVER	1	INCL. ITEMS W/\$
52#&	1811293970	METAL COVER	1	
53#	5811291420	DISH LUG	1	
55#	5811220160	CLUTCH	1	
56#	5811291440	CLIP RIG	2	
57#	5811291450	PINION STOPPER	1	
58#	1811130260	CENTER BRACKET	1	
59#	1811293870	BOLT	3	
60#	1811230240	SHAFT ASSY.	1	INCL. ITEMS W/&
61#&	1811293860	BALL BEARING	1	
64#	5811291600	SHAFT WASHER	1	
65#	5811291590	SHAFT WASHER	2	
66#	5811291580	INSULATE WASHER	1	
67#	1811130730	CENTER COVER	1	
76#	1811270310	SHIFT LEVER	1	
77#	1811291850	LEVER PIN	1	
78#	1811291840	NUT	1	
79#	5811291470	PLATE	1	
80#	5811510360	MAGNETIC SWITCH ASSY.	1	
84#	5811291460	PLUNGER	1	
87#	9821161400	INSULATE BUSING	1	
88#	5811291480	CONNECTOR	1	
89#	5811180190	HOLDER	1	
91#	5811291510	WASHER	2	
92#	5811291520	BOLT	2	
93#	5811291500	TERMINAL ASSY	1	
94#	9821161420	WASHER	1	
97#	5811291490	CLI RING	2	
98#	1811291140	WASHER	2	
99#	5811292140	BOLT	2	
100#	1811293940	STARTER SEAL KIT	1	

ISUZU 6BD1 — ALTERNATOR ASSY.

ALTERNATOR ASSY.

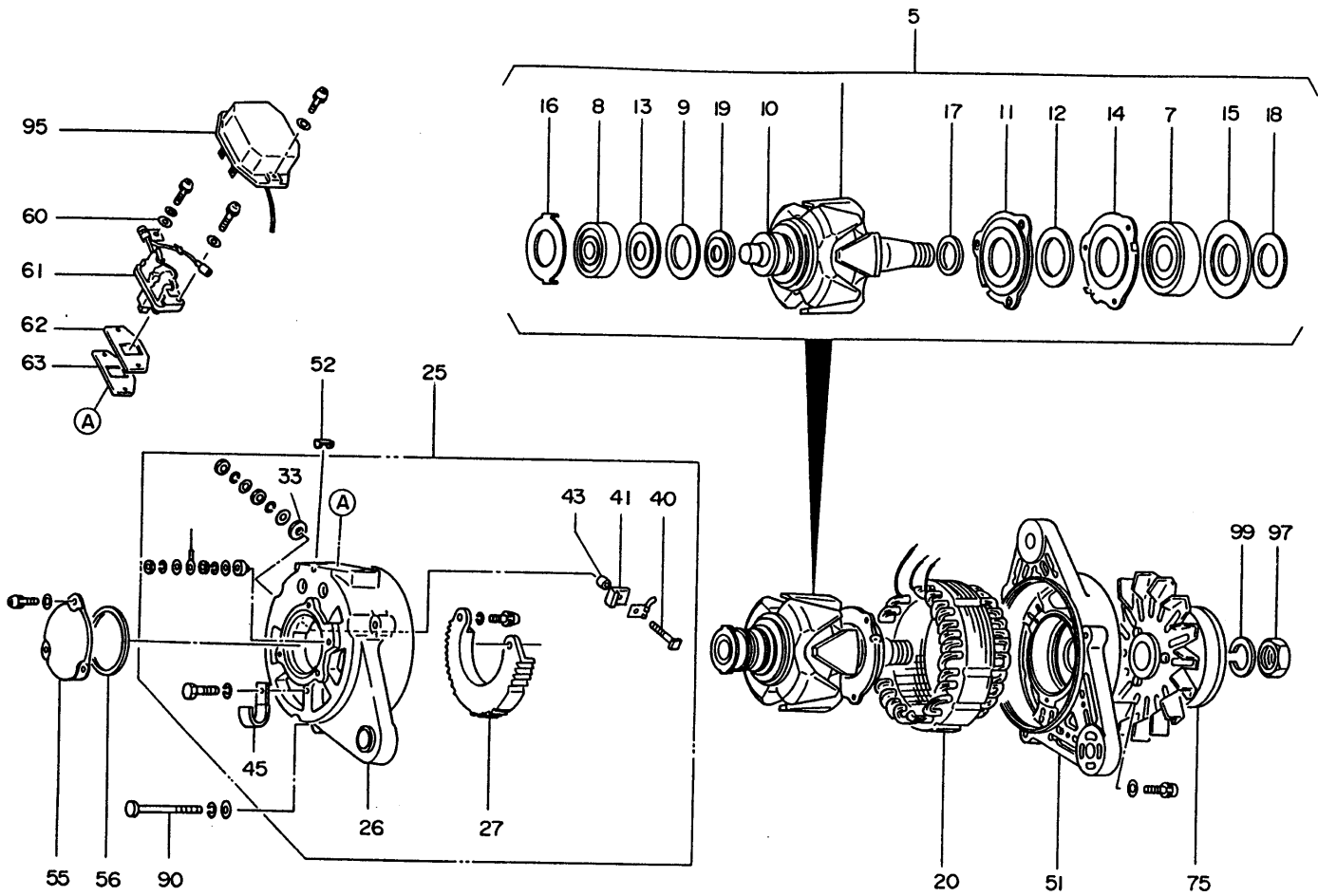

ISUZU 6BD1 — ALTERNATOR ASSY.

ALTERNATOR ASSY.

<u>NO.</u>	<u>PART NO.</u>	<u>PART NAME</u>	<u>QTY.</u>	<u>REMARKS</u>
	1812002050	ALTERNATOR ASSY.	1	INCL. ITEMS W/#
5#	1812210300	ROTOR ASSY.	1	
7#	1812292250	BEARING	1	
8#	1812292240	BALL BEARING	1	
9#	1812292310	ROTOR PACKING	1	
10#	1812240090	SLIP RING	1	
11#	1812291610	ROTOR RETAINER	1	
12#	1812291620	ROTOR PACKING	1	
13#	9822160600	ROTOR RETAINER	1	
14#	1812291630	ROTOR RETAINER	1	
15#	1812291640	ROTOR RETAINER	1	
16#	1812291950	ROTOR CLIP	1	
16-1#	1812292300	ROTOR CLIP	1	
17#	1812291600	COLLAR	1	
18#	1812291650	PACKING	1	
19#	1812291230	PLATE	1	
20#	1812110310	STATOR	1	
25#	1812140810	REAR COVER ASSY.	1	INCL. ITEMS W/@
26#@	1812140820	REAR COVER	1	
27#@	1812190330	RECTIFIER ASSY.	1	
33#@	1812292270	WASHER	2	
40#@	1812293100	BOLT	1	
41#@	1812292350	BUSH	1	
43#@	1812292340	TUBE	1	
45#@	1811180110	CLIP	1	
51#	1812130240	COVER	1	
52#	1812291670	BUSHING	1	
55#	181240830	COVER	1	
56#	1812292330	PACKING	1	
60#	1812291350	WASHER	1	
61#	1812170230	HOLDER ASSY.	1	
62#	1812292260	PACKING	1	
63#	1812292320	PACKIG	1	
75#	1812220340	PULLEY ASSY.	1	
90#	1812290970	BOLT	3	
95#	1812510240	VOLTAGE REGULATOR	1	NOT SHOWN
97#	1812295960	NUT	1	
99#	9822190270	LOCKWASHER	1	

ACCESSORIES

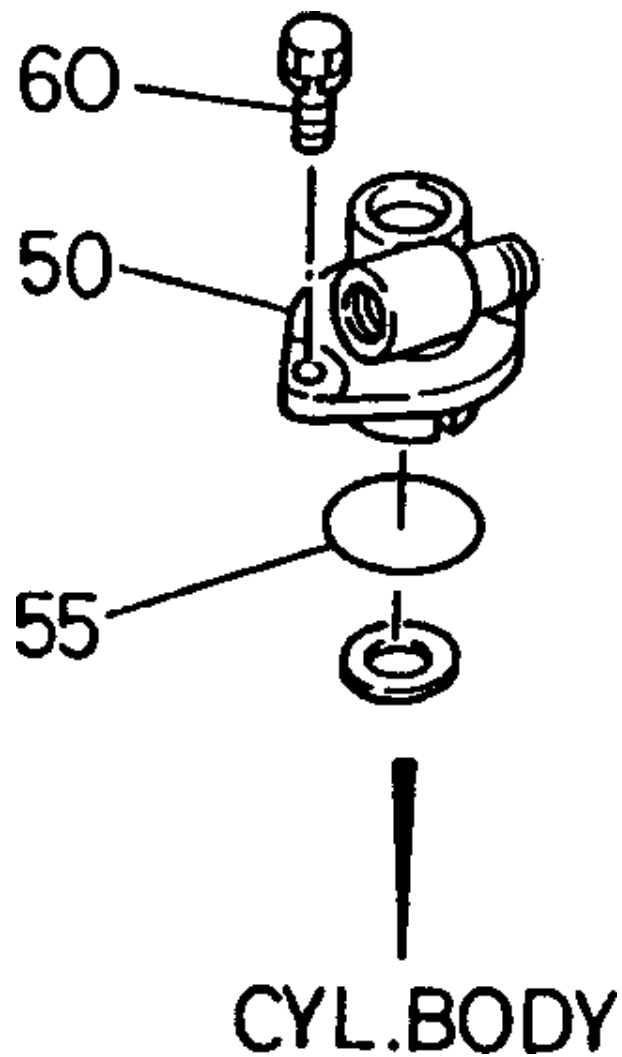

ACCESSORIES

<u>NO.</u>	<u>PART NO.</u>	<u>PART NAME</u>	<u>QTY.</u>	<u>REMARKS</u>
50	9839101011	TACHO DRIVE ELBOW ASSY. .	1	
55	1096231800	PACKING	1	UP TO OCT. 87
	1096234650	PACKING	1	NOV. 87~
60	0500408200	BOLT	2	REPLACES 9019108200

PAYMENT TERMS

Terms of payment for parts are net 10 days.

FREIGHT POLICY

All parts orders will be shipped collect or prepaid with the charges added to the invoice. All shipments are F.O.B. point of origin. Multiquip's responsibility ceases when a signed manifest has been obtained from the carrier, and any claim for shortage or damage must be settled between the consignee and the carrier.

MINIMUM ORDER

The minimum charge for orders from Multiquip is \$15.00 net. Customers will be asked for instructions regarding handling of orders not meeting this requirement.

RETURNED GOODS POLICY

Return shipments will be accepted and credit will be allowed, subject to the following provisions:

1. A Returned Material Authorization must be approved by Multiquip prior to shipment.
2. To obtain a Return Material Authorization, a list must be provided to Multiquip Parts Sales that defines item numbers, quantities, and descriptions of the items to be returned.
 - a. The parts numbers and descriptions must match the current parts price list.
 - b. The list must be typed or computer generated.
 - c. The list must state the reason(s) for the return.
 - d. The list must reference the sales order(s) or invoice(s) under which the items were originally purchased.
 - e. The list must include the name and phone number of the person requesting the RMA.
3. A copy of the Return Material Authorization must accompany the return shipment.
4. Freight is at the sender's expense. All parts must be returned freight prepaid to Multiquip's designated receiving point.
5. Parts must be in new and resalable condition, in the original Multiquip package (if any), and with Multiquip part numbers clearly marked.
6. The following items are not returnable:
 - a. Obsolete parts. (If an item is listed in the parts price book as being replaced by another item, it is obsolete.)
 - b. Any parts with a limited shelf life (such as gaskets, seals, "O" rings, and other rubber parts) that were purchased more than six months prior to the return date.
 - c. Any line item with an extended dealer net price of less than \$5.00.
 - d. Special order items.
 - e. Electrical components.
 - f. Paint, chemicals, and lubricants.
 - g. Decals and paper products.
 - h. Items purchased in kits.
7. The sender will be notified of any material received that is not acceptable.
8. Such material will be held for 5 working days from notification, pending instructions. If a reply is not received within 5 days, the material will be returned to the sender at his expense.
9. Credit on returned parts will be issued at dealer net price at time of the original purchase, less a 15% restocking charge.
10. In cases where an item is accepted for which the original purchase document can not be determined, the price will be based on the list price that was effective twelve months prior to the RMA date.
11. Credit issued will be applied to future purchases only.

PRICING AND REBATES

Prices are subject to change without prior notice. Price changes are effective on a specific date and all orders received on or after that date will be billed at the revised price. Rebates for price declines and added charges for price increases will not be made for stock on hand at the time of any price change.

Multiquip reserves the right to quote and sell direct to Government agencies, and to Original Equipment Manufacturer accounts who use our products as integral parts of their own products.

SPECIAL EXPEDITING SERVICE

A \$20.00 to \$50.00 surcharge will be added to the invoice for special handling including bus shipments, insured parcel post or in cases where Multiquip must personally deliver the parts to the carrier.

LIMITATIONS OF SELLER'S LIABILITY

Multiquip shall not be liable here under for damages in excess of the purchase price of the item with respect to which damages are claimed, and in no event shall Multiquip be liable for loss of profit or good will or for any other special, consequential or incidental damages.

LIMITATION OF WARRANTIES

No warranties, express or implied, are made in connection with the sale of parts or trade accessories nor as to any engine not manufactured by Multiquip. Such warranties made in connection with the sale of new, complete units are made exclusively by a statement of warranty packaged with such units, and Multiquip neither assumes nor authorizes any person to assume for it any other obligation or liability whatever in connection with the sale of its products. A part from such written statement of warranty, there are no warranties, express, implied or statutory, which extend beyond the description of the products on the face hereof.

PARTS AND OPERATION MANUAL

HERE'S HOW TO GET HELP

*PLEASE HAVE THE MODEL AND SERIAL NUMBER
ON-HAND WHEN CALLING*

PARTS DEPARTMENT

800/427-1244 or 310/537-3700

FAX: 800/672-7877 or 310/637-3284

SERVICE DEPARTMENT

800/835-2551 or 310/537-3700

FAX: 310/638-8046

WARRANTY DEPARTMENT

800/835-2551 or 310/537-3700

FAX: 310/638-8046

MAIN

800/421-1244 or 310/537-3700

FAX: 310/537-3927

© COPYRIGHT 2001, MULTIQIP INC.



MULTIQIP INC.

18910 WILMINGTON AVE.
CARSON, CALIFORNIA 90746
310-537-3700
800-421-1244
FAX: 310-537-3927

PARTS DEPARTMENT:

800-427-1244
FAX: 800-672-7877

SERVICE DEPARTMENT:

800-835-2551
FAX: 310-638-8046

E-mail: mq@multiquip.com • **www:** www.multiquip.com

Free Manuals Download Website

<http://myh66.com>

<http://usermanuals.us>

<http://www.somanuals.com>

<http://www.4manuals.cc>

<http://www.manual-lib.com>

<http://www.404manual.com>

<http://www.luxmanual.com>

<http://aubethermostatmanual.com>

Golf course search by state

<http://golfingnear.com>

Email search by domain

<http://emailbydomain.com>

Auto manuals search

<http://auto.somanuals.com>

TV manuals search

<http://tv.somanuals.com>