

# PARTS AND OPERATION MANUAL



## CONCRETE SAW MODELS FS3SP

© COPYRIGHT 2002, MULTIQIP INC.

Revision #0 (07/15/02)



**MULTIQIP INC.**

18910 WILMINGTON AVE.  
CARSON, CALIFORNIA 90746  
310-537-3700  
800-421-1244  
FAX: 310-537-3927

**E-mail:** [mq@multiquip.com](mailto:mq@multiquip.com) • **www:** [www.multiquip.com](http://www.multiquip.com)

Atlanta • Boise • Dallas • Houston • Newark  
Montreal, Canada • Manchester, UK  
Rio De Janiero, Brazil • Guadalajara, Mexico

**PARTS DEPARTMENT:**

800-427-1244  
FAX: 800-672-7877  
**SERVICE DEPARTMENT/TECHNICAL ASSISTANCE:**  
800-478-1244  
FAX: 310-631-5032



# WARNING



## **CALIFORNIA — Proposition 65 Warning**

Engine exhaust and some of its constituents, and some dust created by power sanding, sawing, grinding, drilling and other construction activities contains chemicals known to the State of California to cause cancer, birth defects and other reproductive harm. Some examples of these chemicals are:

- Lead from lead-based paints.
- Crystalline silica from bricks.
- Cement and other masonry products.
- Arsenic and chromium from chemically treated lumber.

Your risk from these exposures varies, depending on how often you do this type of work. To reduce your exposure to these chemicals: **ALWAYS** work in a well ventilated area, and work with approved safety equipment, such as dust masks that are specially designed to filter out microscopic particles.

## **HERE'S HOW TO GET HELP**

*PLEASE HAVE THE MODEL AND SERIAL NUMBER  
ON-HAND WHEN CALLING*

### ***PARTS DEPARTMENT***

*800-427-1244 or 310-537-3700*

*FAX: 800-672-7877 or 310-637-3284*

### ***SERVICE DEPARTMENT/TECHNICAL ASSISTANCE***

*800-478-1244 or 310-537-3700*

*FAX: 310-537-4259*

### ***WARRANTY DEPARTMENT***

*888-661-4279, or 310-661-4279*

*FAX: 310-537-1173*

### ***MAIN***

*800-421-1244 or 310-537-3700*

*FAX: 310-537-3927*

# TABLE OF CONTENTS

Here's How To Get Help ..... 3  
Table Of Contents ..... 4  
Parts Ordering Procedures ..... 5  
Safety Message Alert Symbols ..... 6-7  
Decals ..... 8  
Rules for Safe Operation ..... 9-11  
Dimensions ..... 12  
Weights ..... 13  
Basic Components ..... 14  
Basic Console Components ..... 15-16  
Basic Engine Components..... 17-18  
General Information ..... 19-20

Blade Shaft Assembly ..... 46-47  
Engine Mount Assembly ..... 48-49  
Pointers and Covers Assembly ..... 50-51  
Water System Assembly ..... 52-53  
Basic Platform Assembly..... 54-55  
Blade Mist 20-Inch Assembly ..... 56-57  
Manual Raise and Lower Assembly ..... 58-59  
Battery Box Assembly..... 64-65  
Platform(Bare) Assembly..... 66-67  
Transmission Assembly ..... 69-71

## Engines

Engine Assemblies ..... 72-73

## MQ-Whiteman — FS3SP Concrete Saw

Inspection Engine ..... 21-22  
Inspection Blade ..... 23  
Inspection Blade Placement ..... 24  
Inspection-Guards, Covers, and V-Belts ..... 25-26  
Initial Start-Up ..... 27-28  
Operation ..... 29-30  
Maintenance ..... 31-34  
Explanation Of Codes In Remarks Column ..... 36  
Suggested Spare Parts ..... 37  
Troubleshooting (Engine) ..... 38-39  
Name Plate and Decals..... 40-41  
Under Carriage Assembly ..... 42-43  
Rear Axle Assembly..... 44-45

Terms and Conditions Of Sale — Parts ..... 75

### NOTE

*Specification and part number  
are subject to change without  
notice.*

- Dealer account number
- Dealer name and address
- Shipping address (if different than billing address)
- Return fax number
- Applicable model number
- Quantity, part number and description of each part
- Specify preferred method of shipment:
  - UPS Ground
  - UPS Second Day or Third Day\*
  - UPS Next Day\*
  - Federal Express Priority One (please provide us with your Federal Express account number)\*
  - Airborne Express\*
  - Truck or parcel post

*\*Normally shipped the same day the order is received, if prior to 2PM west coast time.*

## Earn Extra Discounts when you order by FAX!

All parts orders which include complete part numbers and are received by fax qualify for the following extra discounts:

<u>Number of line items ordered</u>	<u>Additional Discount</u>
1-9 items	3%
10+ items**	5%

### Get special freight allowances when you order 10 or more line items via FAX!\*\*

- UPS Ground Service at no charge for freight
- PS Third Day Service at one-half of actual freight cost

No other allowances on freight shipped by any other carrier.

\*\*Common nuts, bolts and washers (all items under \$1.00 list price) do not count towards the 10+ line items.

\*DISCOUNTS ARE SUBJECT TO CHANGE\*

Fax order discount and UPS special programs revised June 1, 1995

**Extra Fax Discount  
for Domestic USA  
Dealers Only**

**Up to 5%  
extra savings!**

**UPS  
Special**  
For faxed orders only

**Now! Direct TOLL-FREE access  
to our Parts Department!**

Toll-free nationwide:

**800-421-1244**

Toll-free FAX:

**800/6-PARTS-7 • 800-672-7877**

# FS3SP CONCRETE SAW — SAFETY MESSAGE ALERT SYMBOLS

## FOR YOUR SAFETY AND THE SAFETY OF OTHERS!

Safety precautions should be followed at all times when operating this equipment. Failure to read and understand the Safety Messages and Operating Instructions could result in injury to yourself and others.

### NOTE

This Owner's Manual has been developed to provide complete instructions for the safe and efficient operation of the MQWhiteman FS3SP Concrete Saws. Depending on the power plant you have selected, please refer to the engine manufacturers instructions for data relative to its safe operations.

**Before using this Concrete Saw, ensure that the operating individual has read and understands all instructions in this manual.**

## SAFETY MESSAGE ALERT SYMBOLS

The three (3) Safety Messages shown below will inform you about potential hazards that could injure you or others. The Safety Messages specifically address the level of exposure to the operator, and are preceded by one of three words: **DANGER**, **WARNING**, or **CAUTION**.



**DANGER:** You **WILL** be **KILLED** or **SERIOUSLY** injured if you do not follow directions.



**WARNING:** You **CAN** be **KILLED** or **SERIOUSLY** injured if you do not follow directions.



**CAUTION:** You **CAN** be injured if you do not follow directions.

Potential hazards associated with Concrete Saw operations will be referenced with Hazard Symbols which appear throughout this manual, and will be referenced in conjunction with Safety Message Alert Symbols.

## HAZARD SYMBOLS



### Lethal Exhaust Gases



Engine exhaust gases contain poisonous carbon monoxide. This gas is colorless and odorless, and can cause death if inhaled. **NEVER** operate this equipment in a confined area or enclosed structure that does not provide ample free flow air.



### Explosive Fuel



Gasoline is extremely flammable, and its vapors can cause an explosion if ignited. **DO NOT** start the engine near spilled fuel or combustible fluids. **DO NOT** fill the fuel tank while the engine is running or hot. **DO NOT** overfill tank, since spilled fuel could ignite if it comes into contact with hot engine parts or sparks from the ignition system. Store fuel in approved containers, in well-ventilated areas and away from sparks and flames. **NEVER** use fuel as a cleaning agent.



### Burn Hazards



Engine components can generate extreme heat. To prevent burns, **DO NOT** touch these areas while the engine is running or immediately after operations. Never operate the engine with heat shields or heat guards removed.



### Rotating Parts



**NEVER** operate equipment with covers, or guards removed. Keep fingers, hands, hair and clothing away from all moving parts to prevent injury.

# FS3SP CONCRETE SAW — SAFETY MESSAGE ALERT SYMBOLS



## Accidental Starting



**OFF** **ALWAYS** place the ON/OFF switch in the OFF position, remove key and/or disconnect the spark plug lead before servicing the engine or equipment. Ground the lead to prevent sparks that could ignite a fire.



## Respiratory Hazard



**ALWAYS** wear approved respiratory protection.



## Over Speed Conditions



**NEVER** tamper with the factory settings of the engine governor or settings. Personal injury and damage to the engine or equipment can result if operating in speed ranges above maximum allowable.



## Sight and Hearing hazard

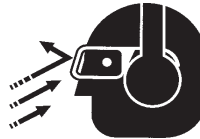

**ALWAYS** wear approved eye and hearing protection.



## Guards and Covers In Place

**NEVER** operate the saw without blade guards and covers in place. Adhere to safety guidelines ANSI American National Standards Institute, OSHA or other applicable local regulations.



## Equipment Damage Messages

Other important messages are provided throughout this manual to help prevent damage to your concrete saw, other property, or the surrounding environment.

### NOTE

This concrete saw, other property, or the surrounding environment could be damaged if you do not follow instructions.

# FS3SP CONCRETE SAW — DECALS

## Machine Safety Decals

The FS3SP Series concrete saws are equipped with a number of safety decals (Figure 1). These decals are provided for operator safety and maintenance information. The illustration below shows these decals as they appear on either concrete saw. Should any of these decals become unreadable, replacements can be obtained from you dealer.

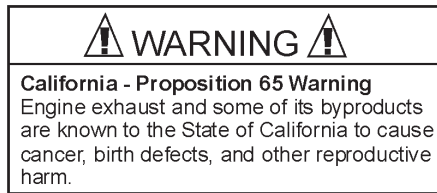

P/N 15582

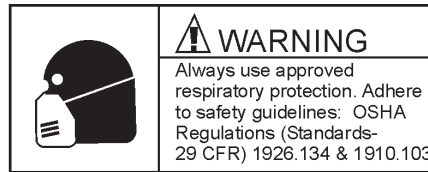

P/N 15580

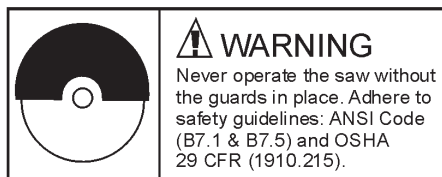

P/N 15581



P/N 15579



P/N 15578

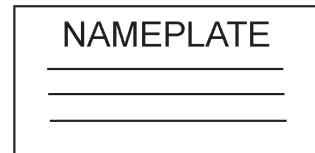

CONTACT MULTIQUIP  
SERVICE DEPT.



P/N 13118



P/N 2942

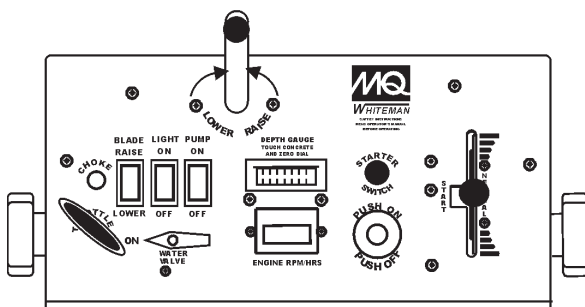

P/N 15740



P/N 15741

Figure 1. FS3SP Decals



# FS3SP CONCRETE SAW — RULES FOR SAFE OPERATION

## WARNING:



Failure to follow instructions in this manual may lead to serious injury or even death! This equipment is to be operated by trained and qualified personnel only! This equipment is for industrial use only.

The following safety guidelines should always be used when operating the MQ Whiteman FS3SP Concrete Saws:

### GENERAL SAFETY

- **DO NOT** operate or service this equipment before reading this entire manual.



- This equipment should not be operated by persons under 18 years of age.

- **NEVER** operate this equipment without proper protective clothing, shatterproof glasses, steel-toed boots and other protective devices required by the job.



- **NEVER** operate this equipment when not feeling well due to fatigue, illness or taking medicine.



- **NEVER** operate this equipment under the influence of drugs or alcohol.



- **NEVER** use accessories or attachments, which are not recommended by Multiquip for this equipment. Damage to the equipment and/or injury to user may result.

- The manufacturer does not assume responsibility for any accident due to equipment modifications.

- Whenever necessary, replace nameplate, operation and safety decals when they become difficult to read.

- **ALWAYS** check the machine for loosened threads or bolts before starting.

- **NEVER** touch the hot exhaust manifold, muffler or cylinder. Allow these parts to cool before servicing engine or saw.



- **High Temperatures** – Allow the engine to cool before adding fuel or performing service and maintenance functions. Contact with **hot** components can cause serious burns.

- The engine section of this saw requires an adequate free flow of cooling air. **NEVER** operate the saw in any enclosed or narrow area where free flow of the air is restricted. If the air flow is restricted it will cause serious damage to the saw or engine and may cause injury to people. Remember the saw's engine gives off **DEADLY** carbon monoxide gas.

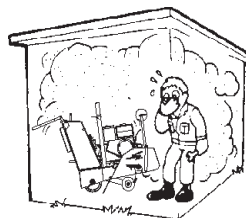

- **ALWAYS** refuel in a well-ventilated area, away from sparks and open flames.

- **ALWAYS** use extreme caution when working with **flammable** liquids. When refueling, **stop the engine** and allow it to cool. **DO NOT** smoke around or near the machine. Fire or explosion could result from fuel vapors, or if fuel is spilled on a hot engine.

- **NEVER** operate the saw in an explosive atmosphere or near combustible materials. An explosion or fire could result causing severe *bodily harm or even death*.



- Topping-off to the **fuel** filler port is dangerous, as it tends to spill fuel.

- **NEVER** use fuel as a cleaning agent.

# FS3SP CONCRETE SAW — RULES FOR SAFE OPERATION

## GENERAL SAFETY

- **ALWAYS** read, understand, and follow procedures in Operator's Manual before attempting to operate equipment.
- **ALWAYS** be sure the operator is familiar with proper safety precautions and operating techniques before using the saw.
- Stop the engine when leaving the saw unattended.
- Block the unit when leaving or when using on a slope.
- Maintain this equipment in a safe operating condition at all times.
- **ALWAYS** stop the engine before servicing, adding fuel and oil.
- **NEVER** Run engine without air filter. Severe engine damage may occur.
- **ALWAYS** service air cleaner frequently to prevent carburetor malfunction.
- **ALWAYS** store equipment properly when it is not being used. Equipment should be stored in a clean, dry location out of the reach of children.
- **NEVER** use accessories or attachments, which are not recommended by Multiquip for this equipment. Damage to the equipment and/or injury to user may result.
- **NEVER** operate this saw in areas that contain combustible material or fumes. Fire and/or explosions may result from errant sparks from the equipment.

## WARNING:



- **DO NOT** operate this equipment unless all guards and safety devices are attached and in place.

- Caution must be exercised while servicing this equipment. Rotating and moving parts can cause injury if contacted.
- Keep all inexperienced and unauthorized people away from the equipment at all times.
- Unauthorized equipment modifications will void all warranties.
- Test the **ON/OFF** switch before operating. The purpose of the switch is to shut down the engine.

## DIAMOND BLADE SAFETY

- Use appropriate steel centered diamond blades manufactured for use on concrete saws.
- **ALWAYS** inspect diamond blades before each use. The blade should exhibit no cracks, dings, or flaws in the steel centered core and/or rim. Center (arbor) hole must be undamaged and true.
- Examine blade flanges for damage, excessive wear and cleanliness before mounting blade. Blade should fit snugly on the shaft and against the inside/outside blade flanges.
- Ensure that the blade is marked with an operating speed greater than the blade shaft speed of the saw.
- Only cut the material that is specified by the diamond blade. Read the specifications of the diamond blade to ensure the proper tool has been matched to the material being cut.
- **ALWAYS** keep blade guards in place. Exposure of the diamond blade must not exceed 180 degrees.
- Ensure that the diamond blade does not come into contact with the ground or surface during transportation. **DO NOT** drop the diamond blade on ground or surface.
- The engine governor is designed to permit maximum engine speed in a no-load condition. Speeds that exceed this limit may cause the diamond blade to exceed the maximum safe allowable speed.
- Ensure that the blade is mounted for proper operating direction.

## SAW TRANSPORTATION SAFETY

- Use the lifting bail and appropriate lifting equipment to ensure the safe movement of the saw.
- **DO NOT** use the handle bars and/or front pointer as lifting points.
- **NEVER** tow the saw behind a vehicle.
- Ensure that both pointer bars are positioned appropriately to minimize their exposure during transportation.
- Safeguard against extreme saw attitudes relative to level. Engines tipped to extreme angles may cause oil to gravitate into the cylinder head making the engine difficult to start.
- **NEVER** transport the saw with the blade mounted.

# FS3SP CONCRETE SAW — RULES FOR SAFE OPERATION

## Emergencies

- **ALWAYS** know the location of the nearest *fire extinguisher* and *first aid kit*. Know the location of the nearest telephone. Also know the phone numbers of the nearest *ambulance*, *doctor* and *fire department*. This information will be invaluable in the case of an emergency.

## Maintenance Safety

- **NEVER** lubricate components or attempt service on a running machine.
- **ALWAYS** allow the machine a proper amount of time to cool before servicing.
- Keep the machinery in proper running condition.
- Fix damage to the machine immediately and always replace broken parts.
- Dispose of hazardous waste properly. Examples of potentially hazardous waste are used motor oil, fuel and fuel filters.
- **DO NOT** use food or plastic containers to dispose of hazardous waste.

# FS3SP CONCRETE SAW — DIMENSIONS

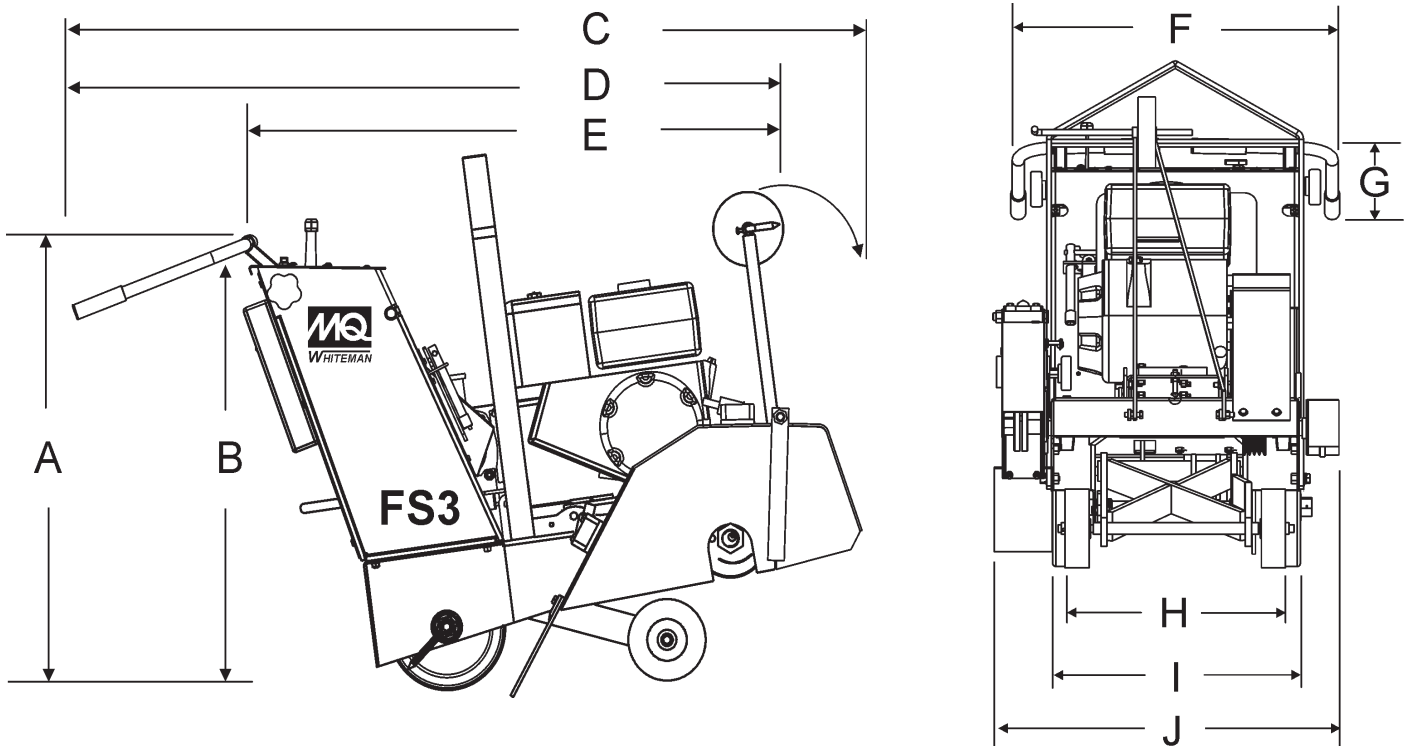

Figure 2. FS3SP Concrete Saw Dimensions

TABLE 1. DIMENSIONS

REFERENCE LETTER	DESCRIPTION	DIMENSION (MM)
A	Max Height (Handle Bars Fully Raised)	45" (1143)
B	Max Height (Handle Bars Fully Lowered)	43" (1092)
C	Max Length (Handle Bars Fully Raised & Front Pointer Lowered)	92" (2337)
D	Max Length (Handle Bars Fully Raised & Front Pointer Raised)	73" (1854)
E	Max Length (Handle Bars Fully Lowered & Front Pointer Raised)	67" (1701)
F	Max Handle Bar Width	28" (711)
G	Max Handle Bar Deflection	12" (305)
H	Front Wheel Base	18" (457)
I	Rear Wheel Base	20" (508)
J	Max Width	28" (711)

Crated Dimension (L x W x H) 47" (1194) x 30" (762) x 44" (1118)

# FS3SP CONCRETE SAW — WEIGHTS

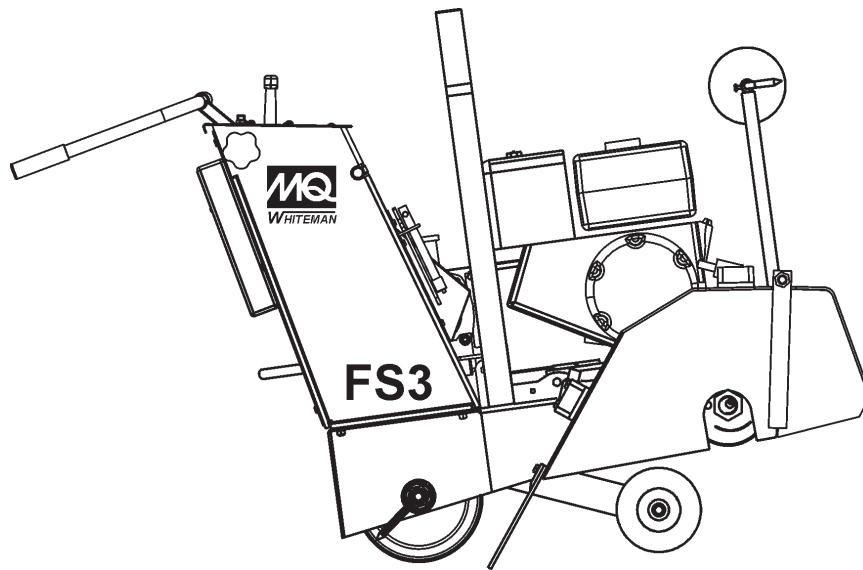

Figure 3. FS3SP Concrete Saw Weights

**TABLE 2. WEIGHTS**

SAW	DESCRIPTION	OPERATING WEIGHT Lbs. (kgs)
FS3SP-20KE14	Saw, 14", Self Prop, 20 HP Kohler, Elec. Start	550(249)
FS3SP-20KE20	Saw, 20", Self Prop, 20 HP Kohler, Elec. Start	555 (252)
FS3SP-20HE14	Saw, 14", Self Prop, 20 HP Honda, Elec. Start	550 (249)
FS3SP-20HE20	Saw, 20", Self Prop, 20 HP Honda, Elec. Start	555 (252)

**Crated Weight (kgs) 600 lbs (272)**

# FS3SP CONCRETE SAW — MAJOR COMPONENTS

## BASIC COMPONENTS

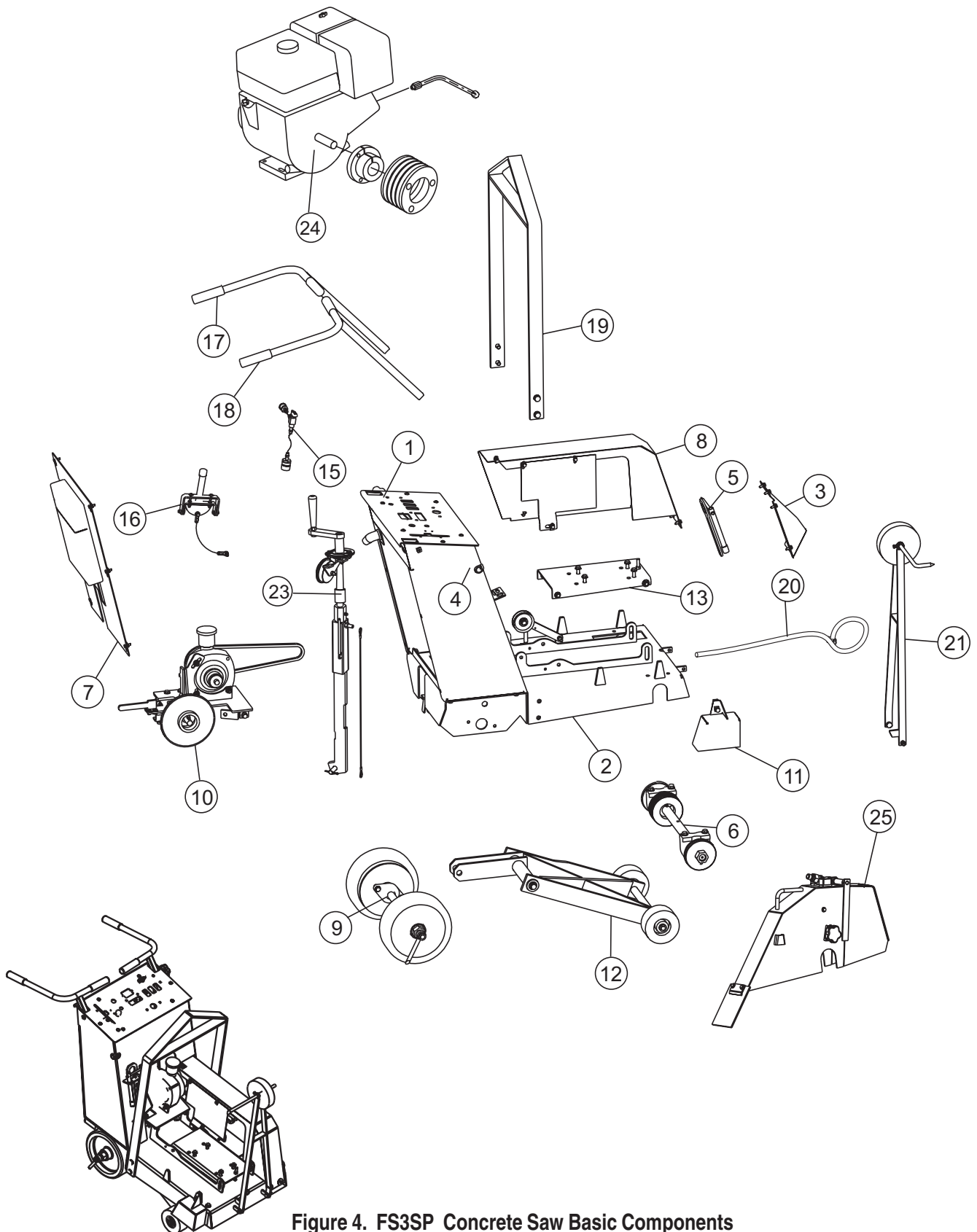

Figure 4. FS3SP Concrete Saw Basic Components

# FS3SP CONCRETE SAW — MAJOR COMPONENTS

BASIC UNIT, FS3 ASSY.

<u>NO.</u>	<u>PART NO.</u>	<u>PART NAME</u>	<u>QTY.</u>	<u>REMARKS</u>
1	15072	HANDLE, CLAMPING	1	See Page 54
2	15200	CHASSIS ASSEMBLY	1	See Page 54
3	15399	COVER, CHAIN ASSEMBLY	1	See Page 50
4	15468	GROMMET, 1.0 X .13 X 1.375	1	See Page 54
5	15523	TOOL KIT	1	See Page 50
6	15573	SHAFT, BLADE ASSEMBLY	1	See Page 46
7	15602	COVER, ASSEMBLY, REAR	1	See Page 54
8	15604	COVER, BELT ASSEMBLY	1	See Page 50
9	15605	AXLE, SP REAR ASSEMBLY	1	See Page 44
10	15606	DRIVE ASSEMBLY, FS3	1	See Page 68
11	15670	COVER, BLADE FLANGE ASSEMBLY	1	See Page 50
12	15674	UNDERCARRIAGE, ASSEMBLY	1	See Page 42
13	15731	MOUNT, ENGINE ASSEMBLY	1	See Page 48
14	15739	FS3, DECAL KIT	1	Not Shown
15	15764	FS3, WATER ASSEMBLY	1	See Page 52
16	15776	HYDROSTATIC THROTTLE ASSEMBLY	1	See Page 70
17	15779	HANDLEBAR ASSEMBLY, LEFT	1	See Page 54
18	15780	HANDLEBAR ASSEMBLY, RIGHT	1	See Page 54
19	15781	FS3, LIFTING BALE KIT	1	See Page 54
20	15830	SASH ASSEMBLY, FS3	1	See Page 50
21	15904	POINTER, FRONT ASSEMBLY	1	See Page 50
22	25252	KIT, SHIPPING	1	Not Shown
23	15569	MANUAL RAISE/LOWER ASSEMBLY	1	See Page 58
24	15750	ENGINE ASSEMBLY	1	See Page 72
25	15652	BLADE GUARD ASSEMBLY	1	See page 56

# FS3SP CONCRETE SAW — CONSOLE COMPONENTS

Figure 5 displays the location of the various operational control features of the FS3SP saw. Features are dependent on the specific model saw selected. The function of each console component or indicator is explained below:

1. **Engine ON/OFF Switch** – *Pull* the switch to permit engine starting. Push the switch to stop engine. Also acts as a fast and secure way to stop the engine in an emergency.
2. **Digital Tachometer/Hourmeter** – Indicates engine RPM and operation hours saw has been in use.
3. **Water ON/OFF Valve** – On position *opens* valve and permits water to flow from source through saw water hose. OFF position *closes* valve and halts the flow of water through the saw.
4. **Throttle Lever** – *Pull* the lever to increase engine RPM. *Push* lever to decrease engine RPM (twist handle to lock).
5. **Choke Lever** – *Pull* lever to assist when starting a cold engine. *Push* lever down after engine warms to disengage choke.
6. **Blade Raise/lower Switch** – Raise position raises blade. Lower position lowers blade.
7. **Light Switch** – On position provides power to external lights. Off position secures power to external lights.
8. **Pump On Switch** – On position provides power to external water pump. Off position secures power to external water pump.
9. **Raise/Lower Crank Handle** – Physically orients saw (Raises/Lowers) depending on turn direction and number of turns. Turning the handle "clockwise" lowers the saw, turning the handle "counter-clockwise" raises the saw. (Used in conjunction with the Depth Feed Gauge)
10. **Depth Feed Gauge** – Indicates the blade cutting depth in inches. To activate, first lower the blade via the **crank handle** until the blade *touches* the cutting surface. Then roll the depth feed dial until the face label reads **zero**.
11. **Start Button** – A spring loaded button, that when pressed actuates the engine start solenoid.
12. **Forward/Reverse Speed Lever** – Controls forward and reverse speeds for self-propelled operation. Provides positive neutral for engine start. **ALWAYS** place transmission engage/disengage lever in the engage position before setting speed lever.
13. **Handle Bar Locking Knobs** – Loosen or tighten these two knobs when making adjustments to the handlebar(s). Turn handle(s) **counter-clockwise** to loosen and **clockwise** to tighten.

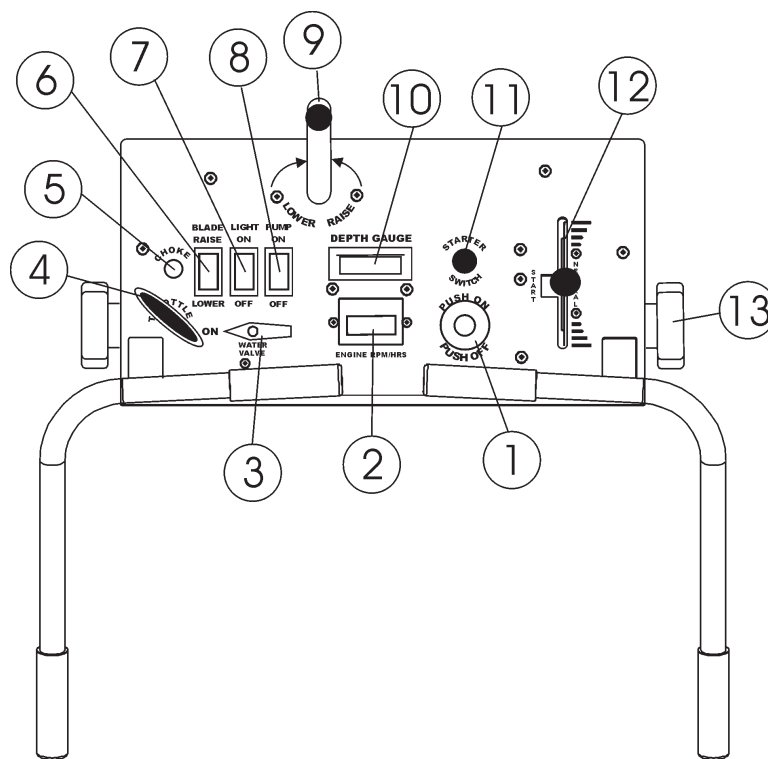

Figure 5. Console Components



# FS3SP CONCRETE SAW — BASIC ENGINE COMPONENTS

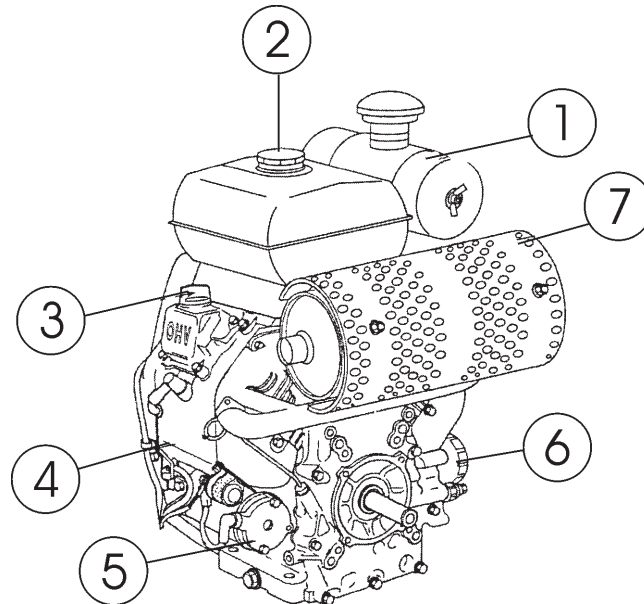

Figure 6. Engine Controls and Components

## INITIAL SERVICING

The engine (Figure 6) must be checked for proper lubrication and filled with fuel prior to operation. Refer to the manufacturers Engine manual for instructions & details of operation and servicing.

1. **Air Filter** – A dirty air filter will restrict airflow to the carburetor, reducing engine performance. When the engine is operated in very dusty conditions, clean the air filter more often than specified in the Maintenance Schedule.

### NOTE

Operating the engine without an air filter, with a damaged air filter, or a filter in need of replacement will allow dirt to enter the engine, causing rapid engine wear.

### To Change/Clean Air Filter

- Remove Air Filter Wing Nut and pull the Air Filter Element out of the filter housing
  - Replace, or clean by using low pressure compressed (30 psi MAX) from inside out.
2. **Fuel Filler Cap** – Remove this cap to add unleaded gasoline (86 Octane rating or higher) to the fuel tank. Make sure cap is tightened securely. The engine fuel tank holds approximately 2 gallons of gasoline. **DO NOT** over fill.



### WARNING

Adding fuel to the tank should be accomplished only when the engine is stopped and has had an opportunity to cool down. In the event of a fuel spill, **DO NOT** attempt to start the engine until the fuel residue has been completely wiped up, and the area surrounding the engine is dry.

3. **Oil Filler Cap** – Check the engine oil level with the engine stopped and in a level position. Oil is a major factor affecting engine performance and service life. Use 4-stroke automotive detergent oil.

**SAE 10W-30** is recommended for general use. Refer to manufacturers Engine Manual for further data regarding other viscosities/temperature limits.

### ENGINE OIL REFILL CAPABILITIES:

- Without Oil Filter Replacement: 1.27 qt. (1.20 L)
- With Oil Filter Replacement: 1.59 qt. (1.20 L)

### NOTICE

Running the engine with a low oil level can cause engine damage. The oil alert system will automatically stop the engine before the oil level falls below safe limits; however, it is advisable to always check the engine oil level before startup.

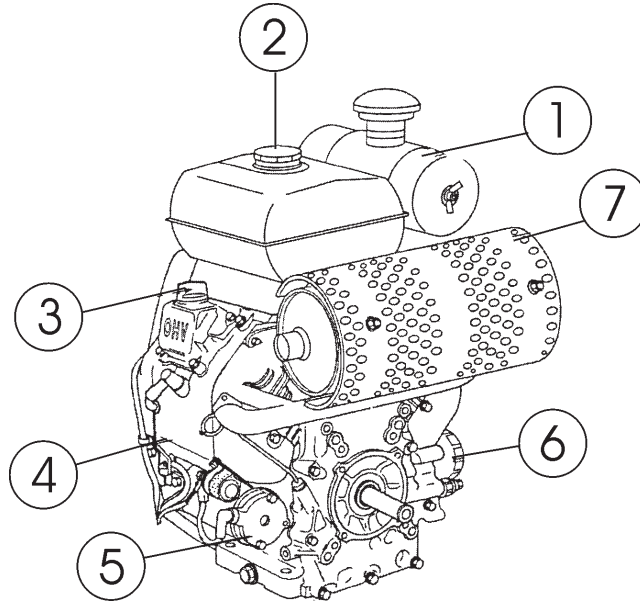

Figure 7. Engine Controls and Components

#### 4. Engine Oil – (See figure 7)

##### A. Engine Oil Dip Stick

- Remove the dipstick and wipe clean.
- Fully insert the dipstick; Then remove it to check the oil level.

##### B. Engine Oil Limits

- Check Oil Level. If the level is low, fill to the upper limit mark on the dipstick with the recommended oil.
- Reinstall the dipstick and screw the oil filter cap securely.

##### C. Engine Oil Filler and Cap.

Ensure that the mouth of the oil filler is kept clean and that the cap is secure after servicing.

##### D. Engine Drain Bolt.

- Drain the used oil while the engine is still warm. Place suitable container to catch the used oil before removing the Engine Drain Bolt.
- Allow used oil to drain completely and then reinstall oil drain bolt and tightly secure.
- Refer to "A. & B." above for Oil Refil.

5. **Electric Starter** – Engine Start is electrically actuated by 12 Volt DC system. Starter button, choke, Throttle Handle, and Engine On/Off Switches are conveniently located on the operating console. (See figure 5)

6. **Oil Filter** – A "Spin On/Off" type oil filter is utilized. It is recommended that the filter be replaced every **(year / or 200 hours of operation)**. Oil Filter tightening torque is approximately 16 ft-lb. (22 N-m, 2.2 kg-m)

#### ⚠ NOTICE

Use only genuine Honda filters or a filter of equivalent quality which is specified by the engine model. Using the wrong filter, or a non-Honda quality equivalent, may cause engine damage.

7. **Muffler** – A high-mount muffler (type "8") is utilized to reduce noise and emissions; as well as deflect engine exhaust away from the operator.

#### ⚠ WARNING



Engine components can generate extreme heat. To prevent burns, do not touch these areas while the engine is running or immediately after operations. Never operate the engine with the muffler removed.

#### ⚠ NOTICE

Dispose of used motor oil in a manner that is compatible with the environment and the Local, State, & Federal laws.

# FS3SP CONCRETE SAW — GENERAL INFORMATION

## FAMILIARIZATION

The MQ Whiteman FS3SP Series concrete saws are designed for wet or dry cutting utilizing diamond blades. They are self-propelled via a hydrostatic transmission system and have been engineered for general, industrial and high production flat sawing applications. The exceptional performance of these saws centers around innovative features, top quality components, and committed attention to state-of-the-art manufacturing.

The reinforced heavy gauge steel frame and chassis assembly has been precisely jig welded to eliminate operational bending and/or flex that would lead to diminished blade performance. Additionally, the general weight-to-strength ratio design of the frame and chassis assembly provides for optimum weight distribution to keep the blade running true in the cut.

An innovative outboard blade shaft bearing assembly ensures minimal flutter and shaft harmonics providing the most advantageous condition for a diamond blade at operating speeds. Also, this design further promotes greater operating life to the blade shaft bearings and V-Belts.

Heavy duty front and rear axles, oversized reinforced wheels supported by roller wheel bearings and locking collars, and industrial under carriage assembly ensure accurate tracking and years of reliable use. The positive locking Raise/Lower screw feed system with accurate depth gauge easily orients blade elevation, and will not permit blade creep during cutting operations.

A robust water plumbing system allows for optimum fluted floodwater to the blade for wet cutting applications.

Operator control of the saw is safely accomplished with adjustable ergonomic handle bars, and a combination of conveniently oriented items on the console such as: Raise/Lower Crank Handle, Tachometer/Hourmeter, ON/OFF Water Valve, Depth Feed Gauge, and Emergency Engine ON/OFF switch. Additionally, the console also provides starting, power control and forward/reverse controls.

**All MQ Whiteman FS3SP saws are designed, engineered and manufactured with strict adherence to American National Standards Institute, Inc. (ANSI) guidelines B7.1 and B7.5.**

## POWER PLANTS

The FS3SP Series saws provides a variety of gasoline engine choices (Table 3). Selection of a specific engine, and its capacity measured in horsepower/torque, directly affects the performance of the diamond blade.

The FS3SP series saws are generally classified in the industry as a "**MEDIUM**" horsepower saw. This classification is particularly useful when selecting the proper diamond blade for an application. Refer to the engine *Owner's Manual* for specific instructions regarding engine operation and maintenance practices.

TABLE 3. POWER PLANTS

ENGINE MFR.	HP	STARTING SYSTEM	AIR CLEANER	FUEL TANK GAL. (Liters)
HONDA	20	Electric	Ind. Dry Canister	1.6 (6.1)
KOHLER	20	Electric	Ind. Dry Canister	1.6 (6.1)

# FS3SP CONCRETE SAW — GENERAL INFORMATION

## UNDER CARRIAGE SYSTEM

A jig welded heavy steel gauge under carriage assembly supports the saw in tracking, pivoting and stabilization. A 1" diameter rear axle supports two solid rubber (10" x 2.75") cast hub wheels with roller bearings, grease fittings and locking collars. A 5/8" diameter front axle supports two solid rubber (5" x 2") cast hub wheels with roller bearings, grease fittings and locking collars. The assembly pivots about two rocker blocks with bushings. See page 42.

## BLADE DRIVE SYSTEM

An innovative blade shaft assembly has been specifically designed to support the optimum distribution of torque from the engine shaft to the blade shaft, and to ensure minimal vibratory conditions on the tips of the shaft.

Balanced engine & blade shaft pulleys are connected to their respective shafts, and four 3VX V-belts connect the engine pulley to the blade shaft pulley. The 1- 1/4" diameter blade shaft is supported by two self-aligning pillow block bearings that are uniquely positioned on the most outboard portion of the reinforced frame.

The combination of pulley and blade shaft bearing positioning ensures minimal vibration & flutter to the ends of the blade shaft. The blade drive system has been designed for left and right hand cutting. See page 46.

## BLADE GUARD ASSEMBLY

The FS3SP offers a 14" or a 20" hinged two-piece, heavy steel gauge blade guard.

Both blade guards provide zinc plated, fluted floodwater manifold assemblies that supply optimum volume and dispersal of water to both sides of the diamond blade for wet cutting. The sizable (6") fluted floodwater tubes resist clogging and are easily removed for maintenance.

The spray pattern and orientation, in conjunction with the design of the blade guard, provides exceptional dust suppression when cutting dry, and may also be desired when the job site requires minimal use of water.

A quick disconnect hose and blade guard are easily removed for fast blade changes, and easily seats itself on the chassis bayonet fitting. The blade guard may be oriented for left or right hand cutting. See pages 56.

## WATER SYSTEM

All FS3 saws provide a water direction system to provide cooling water to the diamond blade. This system consist of : a standard "garden hose" valve that connects the water source (via hose) to the saw, an ON/OFF console water switch, water hose with quick disconnect manifold fittings, and a 14" or 20" blade guard.

## CONSOLE

An ergonomically designed control console allows the operator to easily understand and/or operate the adjustable handlebars, Raise/Lower Crank Handle, Tachometer/Hourmeter, ON/OFF Water Valve, Depth Feed Gauge, and Emergency Engine ON/OFF Switch. Additionally, for electric start and self-propelled models, the console also provides starting, power control and forward/reverse controls.

## MECHANICAL RAISE/LOWER SYSTEM

A positive locking mechanical raise and lower screw feed assembly supports elevation cycling operations. A crank raise/lower handle is located on the console with "**clockwise**" rotation providing lowering action, and "**counter-clockwise**" rotation providing raising action. An ACME precision screw and thread assembly provide accurate travel; while a spring loaded plunge ball system ensures positive height position locking.

An adjustable depth gauge assembly is synchronized with raise/lower handle rotations to accurately depict depth feed. See Table 4 for blade selection with respect to depth of cut. Blade orientation is referenced on the console's depth feed gauge.

TABLE 4. BLADE SELECTION

Diamond Blade Diameter (In.)	Depth of Cut
12"	3-5/8"
14"	4-5/8"
16"	5-5/8"
18"	6-5/8"
20"	7-5/8"

# FS3SP CONCRETE SAW — INSPECTION

## Before Starting

1. Read safety instructions at the beginning of manual.
2. Clean the SAW, removing dirt and dust, particularly the engine cooling air inlet, carburetor and air cleaner.
3. Check the air filter for dirt and dust. If air filter is dirty, replace air filter with a new one as required.
4. Check carburetor for external dirt and dust. Clean with dry compressed air.
5. Check fastening nuts and bolts for tightness.

## Engine Oil Check

1. To check the engine oil level, place the saw on secure level ground with the engine stopped, and the diamond blade removed.
2. Remove the dipstick from the engine oil filler hole (Figure 8) and wipe it clean.

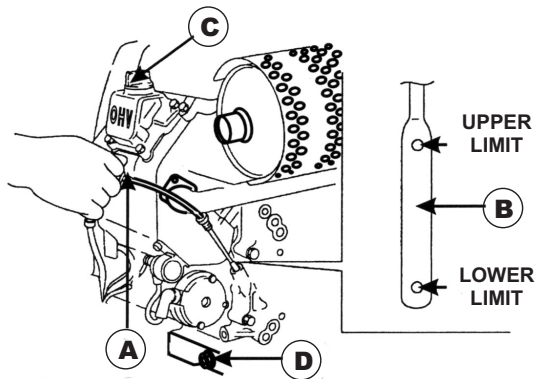

Figure 8. Engine Oil Service

3. Insert and remove the dipstick without screwing it into the filler neck. Check the oil level shown on the dipstick.
4. If the oil level is low (Figure 8), fill to the edge of the oil filler hole with the recommended oil type (Table 5). Maximum oil capacity is 400 cc.

### NOTE

Reference manufacturer engine manual for specific servicing instructions.

### NOTE

FS3SP Series concrete saws have an oil Alert System. This system will automatically stop the **engine** in the event of low oil level. **ALWAYS** be sure to check the engine oil level prior to starting the engine.

Table 5. Oil Type

Season	Temperature	Oil Type
Summer	25°C or Higher	SAE 10W-30
Spring/Fall	25°C~10°C	SAE 10W-30/20
Winter	0°C or Lower	SAE 10W-10

### Explosive Fuel



1. Remove the gasoline cap located on top of fuel tank.
2. Visually inspect to see if fuel level is low. If fuel is low, replenish with unleaded fuel.
3. When refueling, be sure to use a strainer for filtration. **DO NOT** top-off fuel. Wipe up any spilled fuel.

# FS3SP CONCRETE SAW — INSPECTION

**Hydrostatic Transmission** - An EATON® Model 7 hydrostatic transmission (Figure 9) provides the power for the saw's propulsion system. The transmission drives a sprocket that directly connects the rear axle assembly via a drive chain. The "**no load**" forward/reverse speeds are approximately 80 ft/min

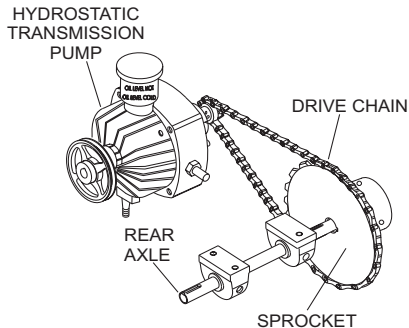

**Figure 9. Hydrostatic Transmission**

1. The transmission is factory filled with approved fluid that has a viscosity equivalent to SAE 20 W 20. Should additional servicing be required, the following oils are recommended:

General Motors Dextron B

Ford MM2C-33F

Ford M2C-41A

International Harvester Hy-Tran Fluids

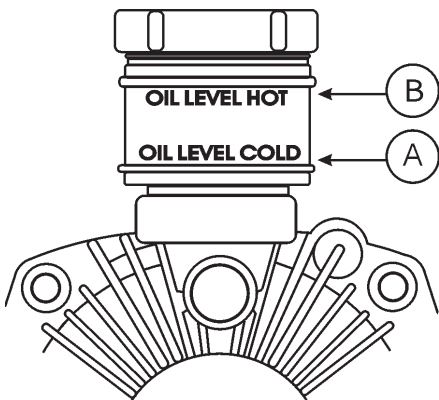
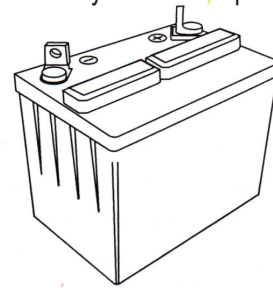

**Figure 10. Transmission Reservoir**

## **NOTICE**

DO NOT overfill the expansion tank. (See figure 10). Note the level marks on the oil reservoir. It is essential to reference the existing oil conditions (A) "cold" or (B) "hot" levels prior to servicing. Overfilling the transmission with oil may cause the seals to rupture, causing mechanical damage.

**Battery** - The 12-Volt DC battery (figure 11) is shipped dry, and will require a proper electrolyte level for operation (electric start models only).



**Figure 11. Battery**

When servicing of the battery is required perform the following:

- A face shield and rubber gloves should be worn while handling and servicing battery's electrolyte.
- **Disconnect** battery terminal clamps, and remove the battery from the saw when servicing is required.
- **DO NOT** overfill the battery.

## **WARNING**

Electrolyte is an acid and must be handled with caution. Servicing instructions from the electrolyte manufacturer must always be followed to ensure safety. Serious injury can result from careless handling and non-compliance to safety handling instructions.



## **WARNING**

Overfilling the battery may cause the electrolyte to overflow resulting in corrosion to nearby components. Immediately wash off any spilled electrolyte (battery acid).

Additionally, when connecting the positive (+) cable to the battery's positive (+) terminal post, **DO NOT** allow contact of the wrench or any metallic part to come in contact with the battery's negative (-) terminal post. This may result in an electrical short circuit or an explosion.

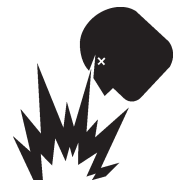

## **NOTICE**

Use only **distilled** water in the battery. Tap water can **reduce** the operating life of the battery.

# FS3SP CONCRETE SAW — INSPECTION -BLADE

## WARNING

Failure to thoroughly inspect the diamond blade (Figure 12) for operational safety could result in damage to the blade, the saw, and may cause injury to the user or others in the operating area.

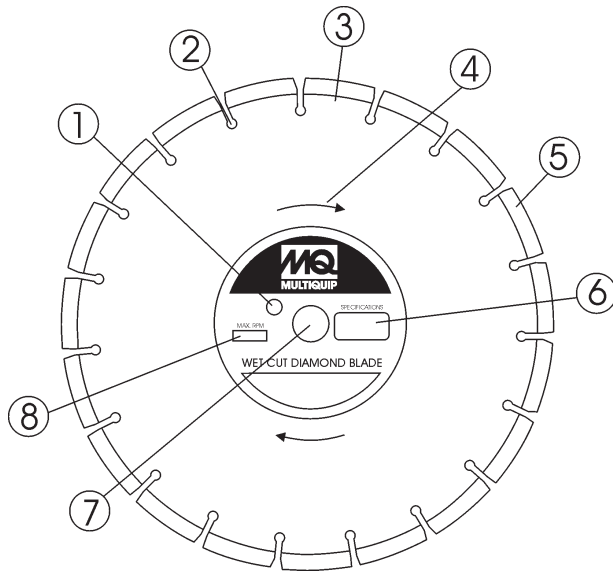

Figure 12. Diamond Blade

- 1. Drive Pin Hole** – A commonly located hole on the diamond blade core that prevents operational blade slippage between the inner & outer blade flanges (collars). Inspect the diameter of the hole to ensure there is no distortion, and that a snug fit develops between the hole and drive pin.
- 2. Stress Relief Holes (Gullets)** – Check the steel core for cracks that may have propagated from the slots and/or gullets. Cracks indicate extreme fatigue failure and if sawing continues, catastrophic failure will occur.
- 3. Edge Of The Steel Core** – Check the diameter edge for discoloration (blue oxidation) indicating an overheating condition caused by insufficient cooling water/air. Overheating of blades may lead to loss of core tension and/or increase the possibility for blade failure. Check to make sure the steel core's width is uniform about the rim of the blade, and not succumbing to an "under cutting" condition brought about by highly abrasive material or improper under cutting core protection.
- 4. Directional Arrow** – Check to ensure that the blade is oriented properly on the blade shaft for sawing. Reference the directional arrow in the blade and place it so the direction of rotation "downcuts" with the turn of the shaft.
- 5. Diamond Segment or Rim** – Ensure there are no cracks, dings, or missing portions of the diamond segment/rim. **DO NOT use a blade that is missing a segment or a portion of the rim.** Damaged and/or missing segments/rims may cause damage to your saw, and injury to the user or others in the operating area.
- 6. Specifications** – Ensure that the blade specifications, size, and diameter properly match up to the sawing operation. Wet blades must have water to act as a coolant. Utilizing a diamond blade not matched properly to the task may result in poor performance and/or blade damage.
- 7. Arbor Hole** – It is essential that the arbor hole diameter properly matches the blade, and that it is free from distortions. Correct blade flanges (collars) must be used. The inside face of the flanges must be clean & free of debris. An out of round arbor condition will cause damage to the blade and the saw.
- 8. MAX RPM** – This RPM reference is the maximum safe operating speed for the blade selected. **NEVER** exceed the max RPM on the diamond blade. Exceeding the MAX RPM is dangerous, and may cause poor performance and may damage the blade.

# FS3SP CONCRETE SAW — INSPECTION -BLADE PLACEMENT

## NOTE

The following steps should be accomplished before placing the diamond blade on the **blade shaft**.

- Place the console ON/OFF button in the OFF position.
  - Raise the saw to a high position by cranking the Raise/Lower handle in a counterclockwise direction.
  - Use the Blade Nut Wrench & Blade Shaft Locking Wrench stored in the lower section of the console to install the diamond blade.
  - Reference Figure 13 (Diamond Blade Placement) when removing or installing the diamond blade.
1. **Belt Guard** – Unscrew the guard security knob and water hose quick disconnect fitting and remove blade guard (1) from its bayonet fitting and set it beside the saw.
  2. **Shaft Lock Tool** – Remove the **shaft lock tool** (2) from the tool holder and insert the pointed end through the front of the saw frame into the machined hole in the blade shaft. A conveniently placed opening on the front of the saw frame permits the use of the shaft lock tool. This tool inhibits the shaft from rotating when applying torque to the blade nut.

3. **Blade Nut Wrench** – Remove the blade nut wrench (3) from the tool holder and unscrew the blade shaft nut (right-side). This nut **loosens clockwise** and **tightens counterclockwise**.
4. **Blade Nut** – Remove the blade nut (4). For reassembly, DO NOT over tighten the blade nut against the outer flange. Tighten blade nut approximately 45-50 ft-lbs/62-69 N/m.
5. **Outside Blade Flange (Collar)** – Ensure that the flange face is clean and free of debris and is placed flush against the diamond blade (7). Check that the drive pin goes through the blade pin hole (6) and seats properly into the inner flange (8).
6. **Blade Pin Hole** – Align this hole with the drive pin hole on the inner flange collar.
7. **Diamond Blade** – Ensure that the proper blade has been selected for the job. Pay close attention to the directional arrow on the blade, **clockwise for right-side** cutting, **counter-clockwise for left-side** cutting. The arbor hole of the blade must match the 1" arbor of the blade shaft.
8. **Inner Flange Collar** – This flange is fixed upon the blade shaft, and is manufactured with a drive pin hole. The inside surface of the flange must be free of debris and permit a tight closure on the surface of the blade.

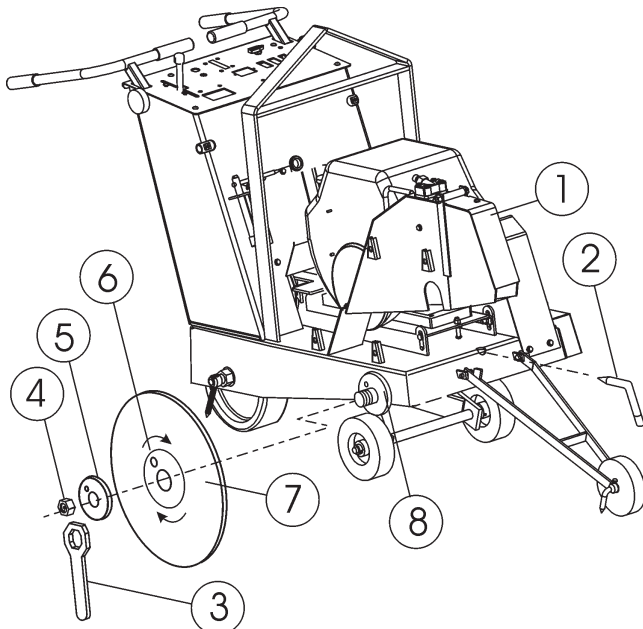

Figure 13. Diamond Blade Placement



# FS3SP CONCRETE SAW — INSPECTION -GUARDS, COVERS & BELTS

## Guards and Covers Check



**NEVER** operate the saw without blade guards and covers (Figures 14 and 15) in place. **DO NOT** operate with the front of the blade guard raised. The blade exposure cannot exceed 180 degrees during operations. Adhere to the safety guidelines of the **American National Standards Institute (ANSI) B7.1 and B7.5**.

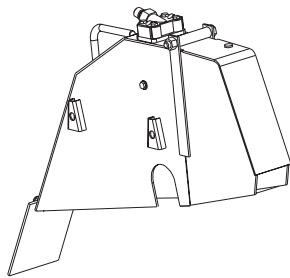

Figure 14. Blade Guard

**CHECK** the following on the "blade guard":

- Check to ensure the capacity of the blade guard matches the diameter of your diamond blade.
- Check that the guard seats firmly upon the bayonet fitting of the saw frame.
- Check that the spring tensioned front cover of the guard is firmly seated with the rear section of the guard, and there are no gaps.
- Check the fit of the water hoses about the two water manifolds (14" guard). **NEVER** lift the blade guard while cutting.
- Check that the flood water tubes and water jets are clear and open. Test the water supply for pressure and flow (to both sides of the blade) before sawing operations.

**CHECK** the following on the "blade flange cover":

- Check that the flange cover seats firmly upon the bayonet fitting of the saw frame prior to operation.
- This flange cover is to be in place when cutting from either the right or left side of the saw.

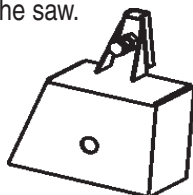

Figure 15. Blade Flange Cover

## V-Belts and Covers

### CAUTION:



**NEVER** attempt to check the V-belt with the engine running because severe injury can occur. Keep fingers, hands, hair and clothing away from all moving parts.

### V-belts Alignment and Tensioning

This concrete saw is equipped with four premium V-belts that have been aligned and tensioned by factory personnel. All four V-belts **MUST** be installed for proper operation of the saw. Failure to run the saw with less than four belts may damage the saw or equipment.

Use the following procedure to check the alignment of V-belts:

1. Remove the bolts that secure the V-belt cover (Figure 16) to the saw frame.

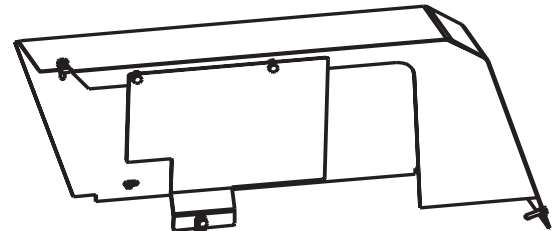

Figure 16. V-Belt Cover

2. Check uniform parallelism (Figure 17) of V-belts and pulley (sheaves). Use a straight edge or machinists's square against both pulleys and adjust both pulleys until equally aligned.

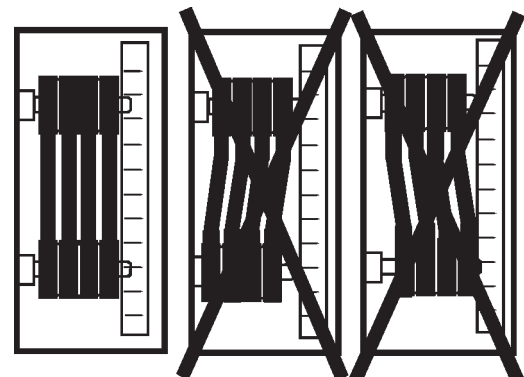

Figure 17. V-Belt Parallelism

3. Check V-belt tension (Figure 18) by using a tensionmeter (6.0 - 9.0 lbs.) against the inside belt at a mid point between the two pulleys, or by deflecting the center belt at a mid point 3/8" (10 mm) - 1/2" (13 mm).

CORRECT V-BELT TENSION 3/8 IN. (10 MM) TO 1/2 IN.(13 MM) WHEN DEPRESSED AT MIDPOINT AS SHOWN

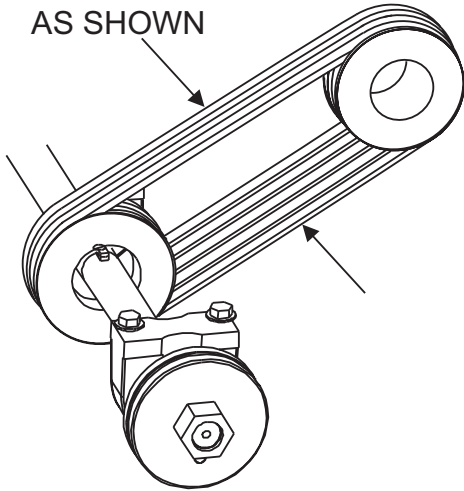

Figure 18. V-Belt Tension

4. **DO NOT** over or under tension the V-belts. Severe damage can occur to the saw and engine crank shaft if the belts are over tensioned. A decrease of power to the blade and poor performance will result if the belts are under tensioned (loose on pulleys).

5. If the V-belts becomes worn or loose, replace them by using the following V-belt part numbers listed in Table 6.

Table 6. V-Belts and Pulleys			
Engine Size	V-Belt P/N	Pulley P/N	Blade Size
20 HP Engine	3VX375 10799	15365	14"
	3VX355 15897	15366	20"

# FS3SP CONCRETE SAW— INITIAL START-UP

## CAUTION:



**DO NOT** attempt to operate the saw until the Safety, General Information and Inspection sections have been read and understood. Depending on engine manufacturer, operating steps may vary. See engine manufacturer's operating manual. The following start-up procedure makes reference to a **HONDA 20 HP Engine**.

1. Ensure the diamond blade has been mounted correctly and that it is raised above the surface you are about to saw.
2. Connect a hose (water source) to the water input port of the saw (see page 50, item 2, **Water System Assembly**), and test for adequate flood water [ 4 to 5 gallons per minute (15 to 19 LT/min)].
3. Set the **Speed Control Lever**(Figure 19) to the start position(neutral) and hold lever against the start microswitch.

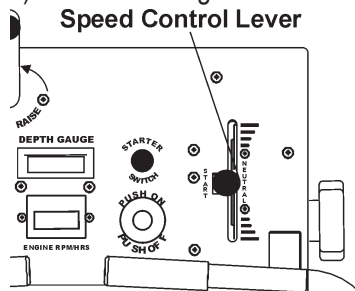
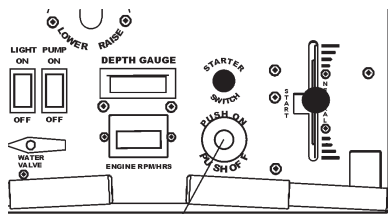

Figure 19. Speed Control Lever

4. **PULL** the Console **Engine ON/OFF switch** (Figure 20) to the "PULL-ON" position.



PULL TO  
START ENGINE

Figure 20 Console Engine ON/Off Switch

## NOTE

The **CLOSED** position of the choke lever enriches the fuel mixture for starting a **COLD** engine. The **OPEN** position provides the correct fuel mixture for normal operation after starting, and for restarting a warm engine.

5. Pull the **Choke Knob** (Figure 21) up into the "**OPEN**" position

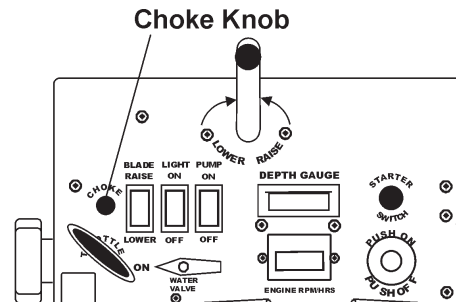

Figure 21. Choke Knob

## CAUTION:



The engine governor speed has been set at the factory. Changing the governor speed could damage the blade and/or the saw.

6. Place the **throttle lever** (Figure 22) halfway between **fast** and **slow** for starting. All sawing is done at full throttle. The engine governor speed is factory set to ensure optimum blade operating speeds.

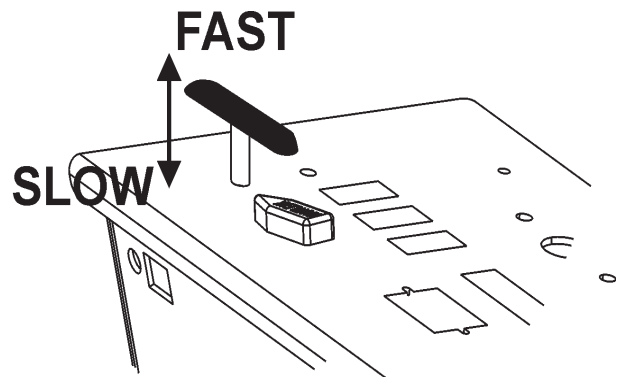

Figure 22. Throttle Lever

# FS3SP CONCRETE SAW — INITIAL START-UP

7. Push the **Start Switch**(Figure 23) to start the engine

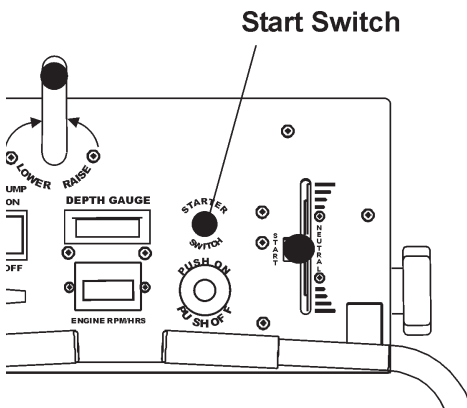

Figure 23. Start Switch

8. If the engine has started, slowly return the choke lever (Figure 23) to the **CLOSED** position. If the engine has not started repeat steps 1 through 5.
9. Before the saw is placed into operation, run the engine for several minutes. Check for fuel leaks, and noises that would associate with a loose guard and/or covers.
10. All sawing is done at full throttle. Your engine governor has been set at the factory to ensure an optimum speed setting.

## Stopping the Engine

**NEVER** stop the engine while the blade is in the cut, except for extreme emergencies. A sudden stoppage of the engine at high speed while in a cut could damage the blade and/or saw, and may cause injury to the user or other in the operating area.

1. Place the throttle lever (Figure 22) in the slow position, and listen for the engine speed to decrease.
2. Push the console engine ON/OFF switch (Figure 20) to the "OFF" position.

## Maneuvering The Saw



The blade is spinning whenever the engine is running.

Raise the blade high above the surface when maneuvering the saw. Damage to the blade and/or saw may occur if the blade strikes the pavement.

## CAUTION:



- **NEVER** stop the engine in the cut while working at high speeds, except for extreme emergencies.

# FS3SP CONCRETE SAW — OPERATION

## Saw Alignment

1. The FS3SP employs a front and rear pointer (Figure 24) that has been precisely aligned with the diamond blade at the factory. Referencing the figure below, accurate tracking is accomplished by referencing the front and rear pointer tips over the cut line. Precise saw direction is accomplished by slight operator pressure against the handle bars.

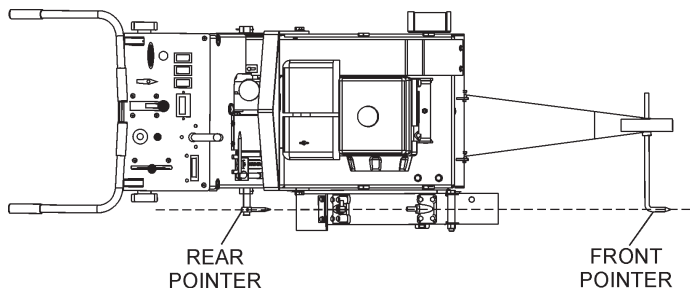

Figure 24. Saw Pointers (Front/Rear)

2. To reorient a pointer position, loosen the screw that secures the pointer bar to the shaft, adjust as necessary, and retighten the screw.
3. For operator comfort, ergonomically designed handle bars adjust by loosening two clamping knobs (Figure 5, item 14), and adjust to the desired height. Tighten the knobs back down when the desired height has been achieved.

## Wet Saw Operation



The operator must wear the appropriate protective equipment and clothing while engaged in sawing.

For wet sawing :

1. Connect hose from water source to the hose fitting connection (see page 52, item 1, **Water System Assembly**) of the saw. The source pressure should be approximately 30-40 psi.
2. Ensure the quick disconnect water hose fitting is connected to the Floodwater manifold of the blade guard.
3. Turn water source on.
4. Select the "ON" position (water valve on the saw console), and ensure the proper flow and rate (4-6 gallons/minute) is equally directed to both sides of the diamond blade.
5. Align the saw along the cut line utilizing the front and rear pointers.

## CAUTION:

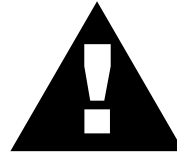

**ALWAYS** saw in a straight line only. Serious damage to the blade may occur if the saw is twisted or forced to cut radius shapes.

6. Slowly lower the diamond blade onto the cut line by cranking the Raise/Lower handle clockwise. When the blade "touches" the cutting surface, "zero-out" the depth feed gauge (Figure 5, item 10) by rolling the depth wheel until "0" is lined up with the slip mark. Slowly continue to lower the blade into the cut until the desired depth is achieved.

**If the water supply to your blade is interrupted - STOP sawing immediately.**

7. Set the sawing depth and saw only as job conditions and specifications require. Deep sawing is wasteful to the life of the blade. The preferred method of sawing is to "**step cut**" in increments of 2" (51 mm). Step cutting provides the optimum opportunity for the blade to cut fast and last it's longest.
8. The rotation of the blade creates a tendency for the saw to slightly pull in a particular direction. To ensure a straight line of sawing, apply pressure against the appropriate handle bar as you slowly advance the saw forward. **DO NOT force the blade into the cut any faster than its designed tendency is effective cut and remove the material.**

# FS3SP CONCRETE SAW — OPERATION

## WARNING

If the engine stalls for any reason during sawing, raise the blade out of the cut before restarting.



10. The operator must recognize and adhere to the optimum speed that the saw advances while sawing. **DO NOT force the saw in the cut.** Observe the engine tachometer from time to time to get the feel for a smooth sawing pace relative to RPM.

11. Factors for sawing economy:

- Type of Blade
- Depth of Cut
- Sawing Speed
- Characteristics of the Material Being Cut
- Wet or Dry Sawing

### Finishing A Cut

1. Raise the blade out of the cut by cranking the Raise/Lower handle counter-clockwise (Figure 5, item 10). Raise the blade high enough out of the cut to clear the surface and allow the saw to be maneuvered.
2. Move the engine throttle lever to the idle (**SLOW**) position (Figure 22).
3. Push the console engine ON/OFF button to the "**OFF**" position (Figure 5, item 1).
4. Set the engine ON/OFF switch to the "**OFF**" position (Figure 6, item 3).
5. Place the water valve (Figure 5, item 3) in the "**OFF**" position (as required).

## WARNING

Engine components can generate extreme heat.



### Diamond Blades and Blade Speed

1. Diamond sawing consist of cutting **WET** (using water to cool the blade) or **DRY** (using the circulating air to cool the blade).
2. Selecting the diamond blade **type** and **grade** defines how the blade will perform both in cutting speed and blade life.

**MULTIQUIP offers a full line of quality diamond blades to match up with your FS3SP, that provide the highest level of sawing value and performance**

### Blade Speed

1. A diamond blade's performance is directly connected to specific peripheral (rim) speeds.
2. The following shaft rotational speeds have been factory set to ensure optimum blade performance.
  - FS3SP 14" Capacity-3,200 RPM.
  - FS3SP 20" Capacity-2,600 RPM.

## WARNING

Operating saw blades at rotational speeds greater than those specified by the manufacture can cause blade damage, and may injure the user or others in the operating area.



# FS3SP CONCRETE SAW — MAINTENANCE

## CAUTION:



General maintenance practices are crucial to the performance and longevity of your saw. The extreme environments of sawing operations require routine cleaning, lubrication, belt tensioning, and inspection for wear and damage



## WARNING

The following procedures devoted to maintenance can prevent serious saw damage or malfunctioning. Before servicing or inspection, **ALWAYS** park the saw on a level surface with the blade removed, and the Console Engine ON/OFF switch & Engine ON/OFF switch in “OFF” position.



## WARNING

Some maintenance operations may require the engine to be run. Ensure that the maintenance area is well ventilated. Exhaust contains poisonous carbon monoxide gas that can cause of unconsciousness and may result in **DEATH**



## General Engine Care

1. **ENGINE CHECK:** Check daily for any oil and/or fuel leakage, thread nut & bolt tightness, and overall cleanliness.
2. **ENGINE OIL:** Check daily. Inspect with blade removed and saw frame level on a level surface. Keep the oil clean, and at the proper servicing level (Figure 7). **DO NOT OVERFILL!** SAE 10W-30 of SG is recommended for general use.
3. **ENGINE OIL CHANGE:** Change engine oil the first month or 20 hours of operation. Then every 3 months/ or 50 HOURS

### NOTE

**ALWAYS** dispose of used oil in a responsible manner. Ensure that the disposition of all hazardous waste is handled properly. Call your Recycling Center for information about recycling engine oil.

4. **ENGINE AIR FILTER:** Clean air filter 2 TO 3 times daily when DRY cutting. See Engine Owner's Manual for detailed information.
5. **ENGINE TANK & STRAINER:** Clean every year/ or 300 hours.
6. **FUEL LINE:** Replace every two years/ or as necessary.
7. **SPARK PLUG:** Clean/adjust every 6 months/or 100 hours. Replace every year/ or 300 hours.

## Bearing Lubrication Care

There are seven (7) grease points for the FS3SP Push Model saw, and nine (9) grease points for the FS3SP Self-Propelled Model saw. [Use only Premium Lithium 12 based Grease, conforming to NLG1 Grade #2 consistency.]

1. **Front Wheels (2):** Grease daily, see page 42, item 3, Undercarriage Assembly.
2. **Rear Wheels (2):** Grease daily, see page 44, item 10, Rear Axle Assembly.
3. **Blade Shaft Bearings (2):** Grease daily, see page 46, item 6, Blade Shaft Assembly.
4. **Raise/Lower Adjust Tube (1):** Grease daily, see page 58, item 20, Raise/Lower Assembly.
5. **Transmission Shaft Bearings (2):** Grease weekly, see page 68, item 16, Transmission Assembly.

### NOTE

When cutting **DRY**, lubricate blade shaft bearings 2 to 3 times daily. The grease can provide an added protective seal for the bearings.

## General Transmission Care

All FS3SP Models utilize spline gear wheel design coupled with an EATON Model 7 Hydrostatic Transmission that provides forward/reverse propulsion. The simple design of the system keeps maintenance to a minimum.

1. **Transmission Reservoir Cup:** Check every 8 hours of operation. When the transmission is **cold** (A), check oil level against the level indicator (see Figure 25).

**DO NOT use multiple viscosity oils! DO NOT OVERFILL.**

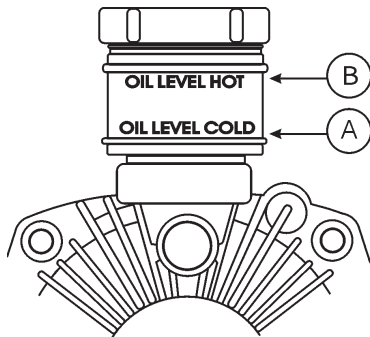

Figure 25. Transmission Reservoir

2. **Servicing:** The transmission reservoir is factory filled. Should servicing be required, use SAE20W-20, API classification (SE,CC,CD) or better, General Motors Dexron B, Ford M2C-33F, M2C-41A or International Harvester Hy-Tran fluids. For extreme **hot weather**, drain oil and refill with an oil having a viscosity of SAE30W-30 or SAE40W-40.

3. **Drive Chain:** Check every 50 hours. Periodically wipe the chain clean and relubricate with penetrating chain oil.

The drive chain may stretch requiring tension adjustments. Loosen the (3) transmission attachment screws (see page 68, item 11), and pivot the transmission in the “U” slots of the **transmission mount** until the proper tension is achieved. (see page 68, item 12). **EXCESSIVE TENSION ON THE DRIVE CHAIN WILL REDUCE CHAIN LIFE.**

## Adjust V-Belt Alignment/Replacement Pulleys

The V-belts and their respective pulleys have been professionally aligned at the factory. If there is a requirement to remove/replace or adjust the pulleys, proceed with the following instructions.

1. Select the proper sized pulley both in outside diameter and arbor size. **Use approved Multiquip parts to ensure the component compatibility.**
2. A change in Pulley diameters may require specifically sized V-Belts. **Contact Multiquip Service Department to ensure V-Belt compatibility.**

## Complete Drive V-Belt(s) Replacement steps (1 through 7)

3. Remove the V-Belts from around the Pulley(s).
4. Remove the set screws that secure the pulleys to the respective shafts (PTO shaft) for engine pulley or the (blade shaft) for the blade shaft pulley.
5. Remove/replace the pulley by sliding it off the shaft.
6. Reorient the new pulley on the shaft, and ensure precise pulley alignment by utilizing an accurate straight edge (see Figures 26 and 27).
7. Replace/tighten set screws treated with a drop of **LOCTITE Threadlocker 266**.
8. Orient the proper replacement V-Belt(s) around the blade shaft pulley and engine pulley.
9. Reference the final stages of the **Drive V-Belt(s) Replacement** steps.

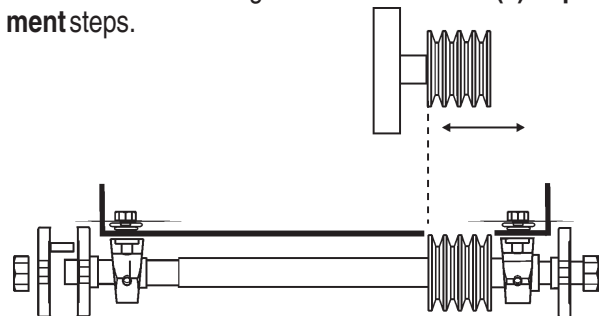

Figure 26. Pulley Alignment

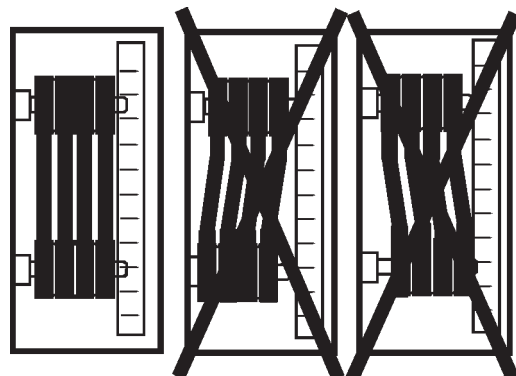
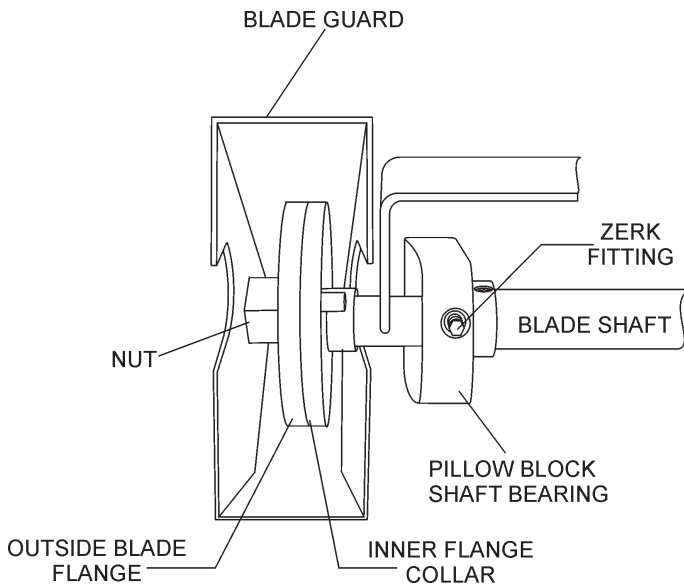

Figure 27. V-Belt Alignment



## Blade Shaft Bearing Replacement

The FS3SP is supported by “tapped base lock collar (w/set screw)” self-aligning blade shaft bearings. These heavy duty bearings support the 1-1/4 blade shaft, and have grease (zerk) points (Figures 28 and 29) conveniently located for service.



**Figure 28. Right-Side Shaft Bearing**

1. Reference pages 46 (*Blade Shaft Assembly*) and 72 (*Engine Mount Assembly*).
2. Its recommended to replace both left & right hand bearings collectively.

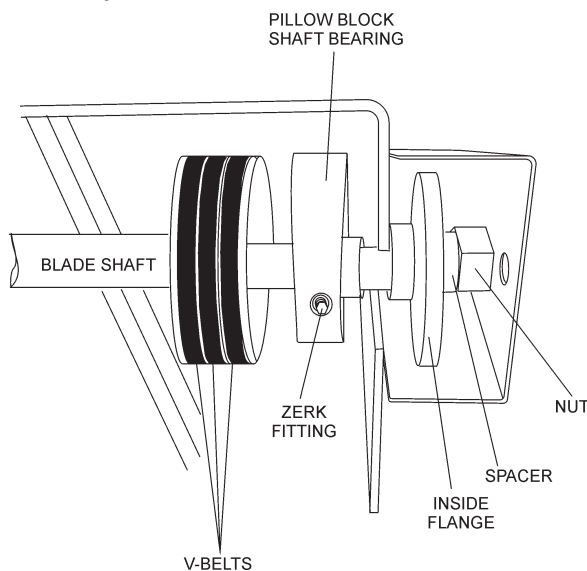

**Figure 29. Left-Side Shaft Bearing**

3. To loosen the tension on the three V-Belts perform the following:

- Remove the **Belt Guard**, item, page 50, item 17 (Pointers and Covers Assembly)
- Loosen the **Carriage Bolt**, page 48, item 4 (Engine Mount Assembly).
- Loosen the **Hex Head Cap Screws**, page 48, item 7 (Engine Mount Assembly).
- Rotate the engine down to provide slack in the V-Belts

## Replacement of the Blade Shaft Bearings

4. Perform the following to replace the blade shaft bearings:
  - Remove **blade flanges** (page 46, items 7 and 8, **Blade Shaft Assembly**) as required to permit the Shaft Bearing(s) to slide off the blade shaft.
  - Loosen/remove shaft bearing(s) **hex head cap screws**, page 44, item 11.
  - Loosen **set screw** on the blade shaft bearing collar.
  - Slide “old” bearing(s) off the blade shaft and replace with “new” bearing(s)- grease (zerk) fitting pointing forward, and the lock collar oriented to the “right” as you face the saw.
5. Loosely bolt the bearing(s) into place on the saw frame, then ensure the alignment by referencing past bearing positioning.
6. Tighten the hex head cap screw, page 46, item 11 to secure the shaft bearing (s) to the frame.
7. To complete the re-installation process, reverse the order of the above mentioned steps. For V-belt adjustment and tensioning see pages 32 (Figures 26 and 27) and page 34 (Figure 30).

## Drive V-Belt Check

Operating the saw with less than four (4) V-belts, or belts that are **slipping** or are **Over Tensioned** will significantly diminish the performance of the saw, and may cause damage to the blade.

1. The V-Belts of the FS3SP have been factory set utilizing precision standards.

## Drive V-Belt(s) Replacement

Reference Pointers and Covers Assembly (page 50), Blade Shaft Assembly (page 46), Engine Mount Assembly (page 48) for this operation.

1. Remove the Belt Guard (page 50, item 17), then loosen the tension of the V-Belts
2. Loosen the Engine Mount Carriage Bolt (page 48, item 4).
3. Loosen the (4) 3/8" HHC screws (page 48, item 7).
4. Rotate the engine down to provide slack in the V-Belts.
5. Loosen the (2) 3/4" HHC screws that support the Blade Shaft Bearings on the **right-side** of the saw (page 46, item 11, also see Figure 30).
6. Remove the (2) 3/4" HHC screws that secure the Blade Shaft Bearing on the **V-Belt side** of the saw (page 46, item 11 also see Figure 30).

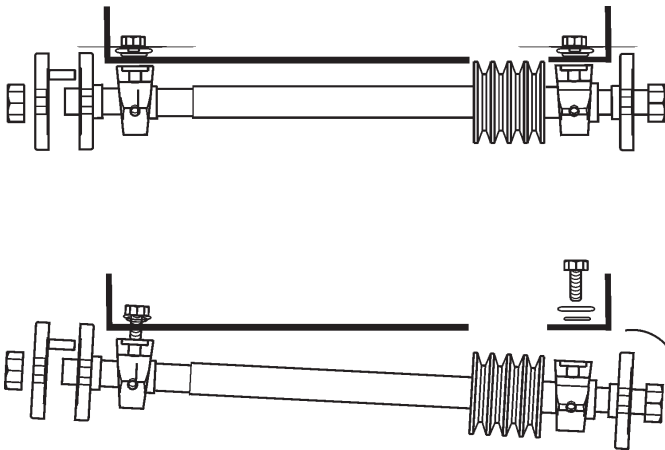

Figure 30. V-Belt Removal

7. Orient the blade shaft so the belt(s) to be replaced can slide off of the blade shaft pulley and engine pulley.
8. Select the proper Multiquip replacement V-Belts (see page 46, item 12).
9. Remove the worn V-Belt(s).
10. Orient the proper replacement V-Belt(s) around the blade shaft pulley and engine pulley.
11. Replace and tighten the (4) 3/4" HHC screws that secure the Blade Shaft Bearings to the saw frame.

## Adjust V-Belt Tension

1. Tighten down the engine mount **carriage bolt** (page 48, item 4,) and monitor the tension on the belts.
2. Determine the proper tension (Figure 31) by using a tensionmeter against the inside belts at mid point between the two pulleys (6-9 lbs.), or by deflecting the center belts at mid point 3/8" (10 mm) to 1/2" (13 mm).

CORRECT V-BELT TENSION 3/8 IN. (10 MM) TO 1/2 IN. (13 MM) WHEN DEPRESSED AT MIDPOINT AS SHOWN

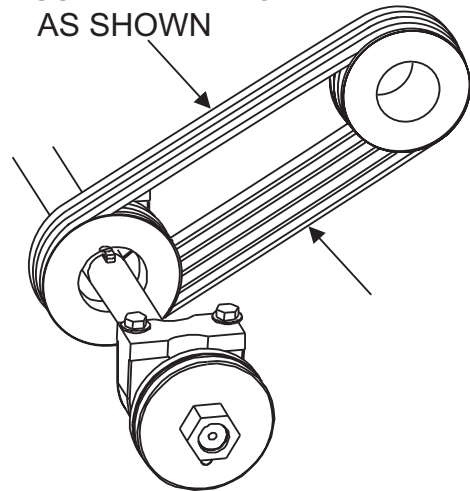

Figure 31. V-Belt Adjustment/Tension

3. Once the proper tension has been applied to the belts, tighten the (4) 3/8" HHC screws (page 48, item 7).
4. Replace and secure the **Belt Guard** (page 50, item 17).

## General Cleanliness

**Clean the machine daily.** Remove all dust and slurry build up. If the saw is steam cleaned, ensure that lubrication is accomplished **AFTER** steam cleaning operations.



# FS3SP SAW — EXPLANATION OF CODE IN REMARKS COLUMN

How to read the marks and remarks used in this parts book.

## Section 1: Items Found In the “Remarks” Column

Serial Numbers-Where indicated, this indicates a serial number range (inclusive) where a particular part is used.

Model Number-Where indicated, this shows that the corresponding part is utilized only with this specific model number or model number variant.

## Section 2: Items Found In the “Remarks” Column

Serial Numbers-Where indicated, this indicates a serial number range (inclusive) where a particular part is used.

Model Number-Where indicated, this shows that the corresponding part is utilized only with this specific model number or model number variant.

## Section 3: Items Found In the “Items Number” Column

All parts with same symbol in the number column, \*, #, +, %, or ■, belong to the same assembly or kit.

Note: If more than one of the same reference number is listed, the last one listed indicates newest (or latest) part available.

### NOTE

The contents of this parts catalog are subject to change without notice.

# FS3SP CONCRETE SAW — SUGGESTED SPARE PARTS

FS3SP CONCRETE SAW 1 TO 3 UNITS

## *1 to 3 Units*

Qty. .... P/N ..... Description

# FS3SP CONCRETE SAW — TROUBLESHOOTING (ENGINE)

## TABLE 7. ENGINE TROUBLESHOOTING

SYMPTON	POSSIBLE CAUSE	SOLUTION
Difficult to start, "fuel is available, but no SPARK at spark plug".	Spark plug bridging?	Check gap, insulation or replace spark plug.
	Carbon deposit on spark plug?	Clean or replace spark plug.
	Short circuit due to deficient spark plug insulation?	Check spark plug insulation, replace if worn.
	Improper spark plug gap?	Set to proper gap.
Difficult to start, "fuel is available, and SPARK is present at the spark plug".	Console or engine ON/OFF switch is shorted?	Check switch wiring, replace switch.
	Ignition coil defective?	Replace ignition coil.
	Improper spark gap, points dirty?	Set correct spark gap and clean points.
	Condenser insulation worn or short circuiting?	Replace condenser.
	Spark plug wire broken or short circuiting?	Replace defective spark plug wiring.
Difficult to start, "fuel is available, spark is present and compression is normal"	Wrong fuel type?	Flush fuel system, and replace with correct type of fuel.
	Water or dust in fuel system?	Flush fuel system.
	Air cleaner dirty?	Clean or replace air cleaner.
Difficult to start, "fuel is available, spark is present and compression is low"	Suction/exhaust valve stuck or protruded?	Re-seat valves.
	Piston ring and/or cylinder worn?	Replace piston rings and or piston.
	Cylinder head and/or spark plug not tightened properly?	Torque cylinder head bolts and spark plug.
	Head gasket and/or spark plug gasket damaged?	Replace head and spark plug gaskets.
No fuel present at carburetor.	Fuel not available in fuel tank?	Fill with correct type of fuel.
	Fuel cock does not open properly?	Apply lubricant to loosen fuel cock lever, replace if necessary.
	Fuel filter clogged?	Replace fuel filter.
	Fuel tank cap breather hole clogged?	Clean or replace fuel tank cap.
	Air in fuel line?	Bleed fuel line.

# FS3SP CONCRETE SAW — TROUBLESHOOTING (ENGINE)

**TABLE 7. ENGINE TROUBLESHOOTING (CONTINUED)**

SYMPTON	POSSIBLE CAUSE	SOLUTION
"Weak in power" compression is proper and does not misfire.	Air cleaner not clean?	Clean or replace air cleaner
	Improper level in carburetor?	Check float adjustment, re-build carburetor.
	Defective Spark plug?	Clean or replace spark plug.
	Defective Spark plug?	
"Weak in power" compression is proper but misfires.	Water in fuel system?	Flush fuel system, and replace with correct type of fuel.
	Dirty spark plug?	Clean or replace spark plug.
	Ignition coil defective?	Replace ignition coil.
Engine overheats.	Spark plug heat value improper?	Replace with correct type of spark plug.
	Correct type of fuel?	Replace with correct type of fuel
	Cooling fins dirty?	Clean cooling fins.
Rotational speed fluctuates.	Governor adjusted correctly?	Adjust governor.
	Governor spring defective?	Replace governor spring.
	Fuel flow restricted?	Check entire fuel system for leaks or clogs.
Recoil starter malfunction.	Recoil mechanism clogged with dust and dirt?	Clean recoil assembly with soap and water.
	Spiral spring loose?	Replace spiral spring.

**TABLE 8. SELF-PROPULSION TROUBLESHOOTING**

SYMPTON	POSSIBLE CAUSE	SOLUTION
Transmission Does Not Engage	Broken Drive Chain	Replace/Repair Drive Chain
	Spline Gear Does Not Make Proper Contact With Rear Wheels	Adjust Spline Gear Control Rod
Transmission Operates in One Direction	Loose Transmission Drive Linkage	Adjust Transmission
Transmission Operating Very HOT	Loose Transmission Drive Linkage	Adjust Transmission
	Low Oil Level	Service Transmission Filler Cup
	Cooling Louvers of the Transmission is Caked With Cutting Slurry	Thoroughly Clean Transmission Casing
Saw Slips and Demonstrates Jerky Motion When Engaged	Loose Transmission Drive Linkage	Adjust Transmission
	Loose Drive Chain	Adjust Drive Chain
	Low Oil Level	Service Transmission Filler Cup
Oil in Reservoir is Dark/Milky in Color	Water in Reservoir or Extreme Overheating Has Occured	Clean recoil assembly with soap and water.

# FS3SP CONCRETE SAW — NAME PLATE AND DECALS

NAME PLATE AND DECALS.

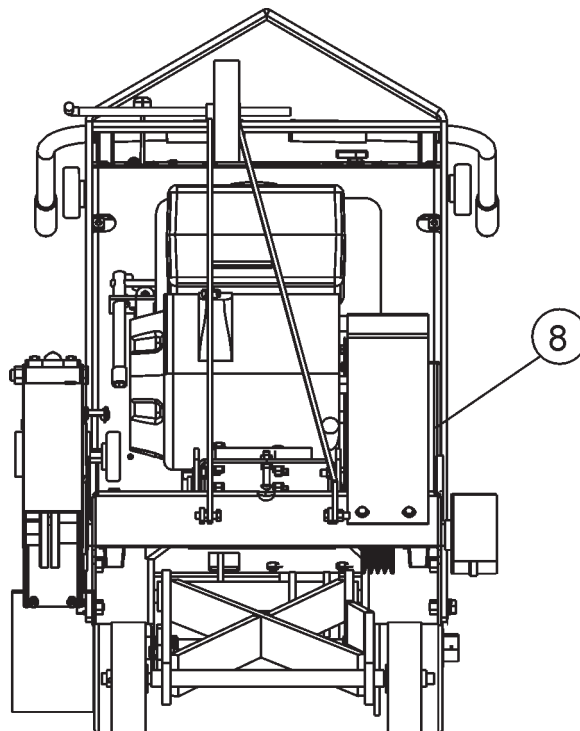
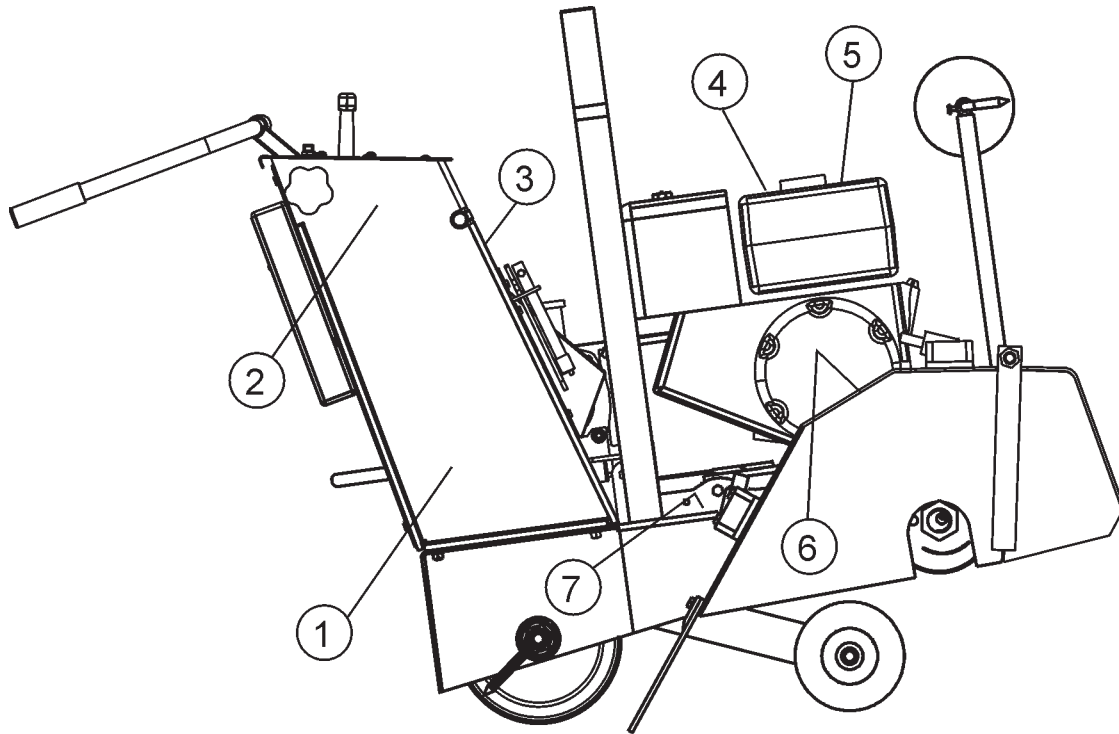



# FS3SP CONCRETE SAW — NAME PLATE AND DECALS

## NAME PLATE AND DECALS

NO	PART NO	PART NAME	QTY.	REMARKS
1*	15578	DECAL: FS3 (WHITE)	2	
2*	15579*	DECAL: MQ WHITEMAN 5.5" X 4"	2	
3	13118	DECAL: POWDER COATED	1	
4*	15582	DECAL: WARNING PROP. 65	1	
5*	15580	DECAL: WARNING RESPIRATORY	1	
6	15581	DECAL: WARNING BLADE GUARD	1	
7		PLATE: SERIAL NO. ....	1	..... CONTACT MQ SERVICE DEPT. W/MODEL & S/N
8*	2942	DECAL: MQ WHITEMAN 13"	1	
9	15739	DECAL: KIT FS3 .....	1	..... INCLUDES ITEMS W/*

SEE DECAL ILLUSTRATIONS ON PAGE 8.

# FS3SP CONCRETE SAW — UNDER CARRIAGE ASSY.

UNDER CARRIAGE ASSY.

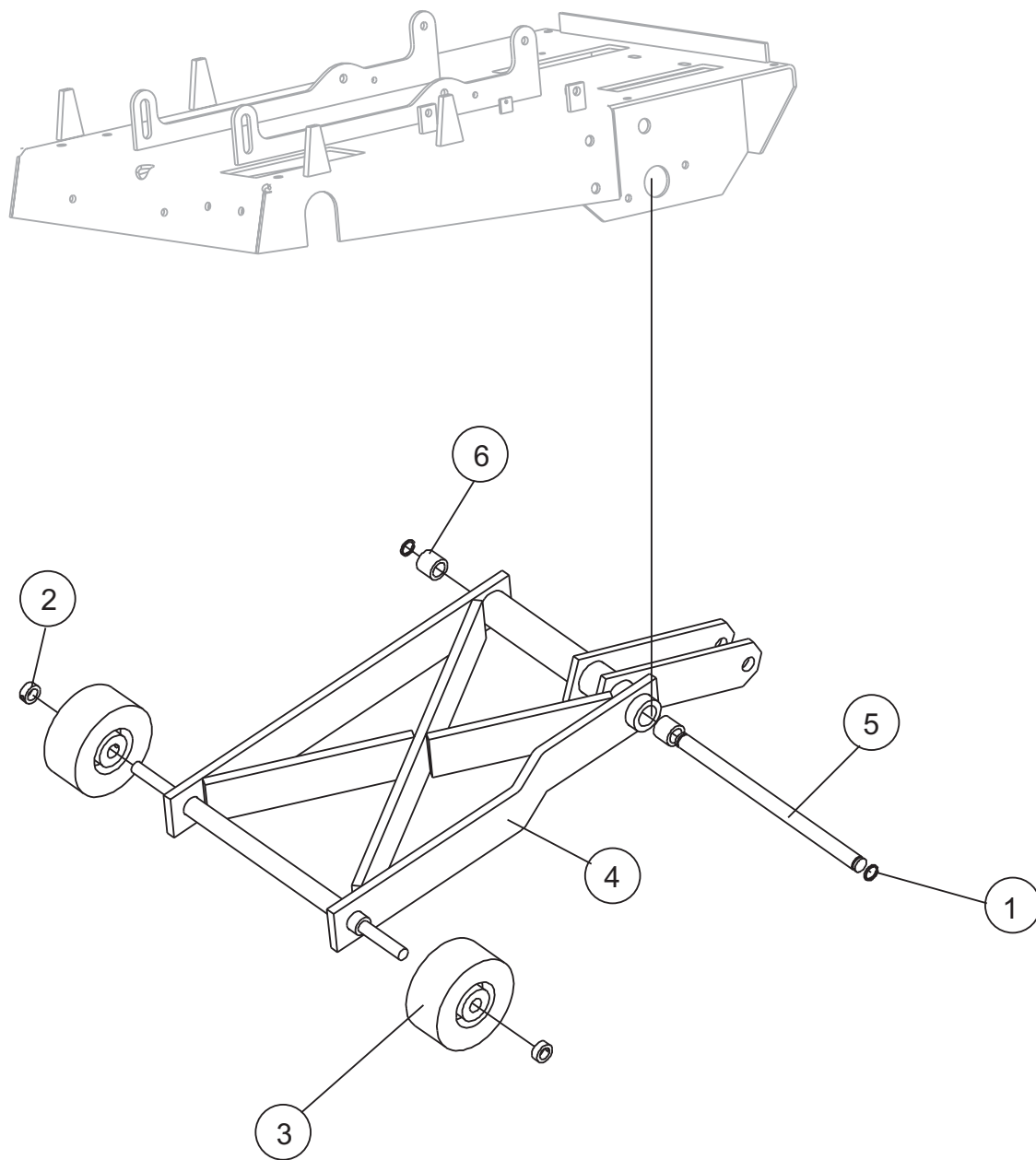

# FS3SP CONCRETE SAW — UNDER CARRIAGE ASSY.

## UNDERCARRIAGE ASSY.

<u>NO.</u>	<u>PART NO.</u>	<u>PART NAME</u>	<u>QTY.</u>	<u>REMARKS</u>
1	10512	RING, SNAPTRUARC #5100-56	2	
2	15028	SET COLLAR, 5/8 DIAMETER	2	
3	15090	WHEEL, 5D X 2W X .625 ID #400 CAP	2	
4	15202	UNDERCARRIAGE W/A	1	
5	15377	AXLE, PIVOT, UNDERCARRIAGE	1	
6	15382	BUSHING, PIVOT AXLE	2	

# FS3SP CONCRETE SAW — REAR AXLE ASSY.

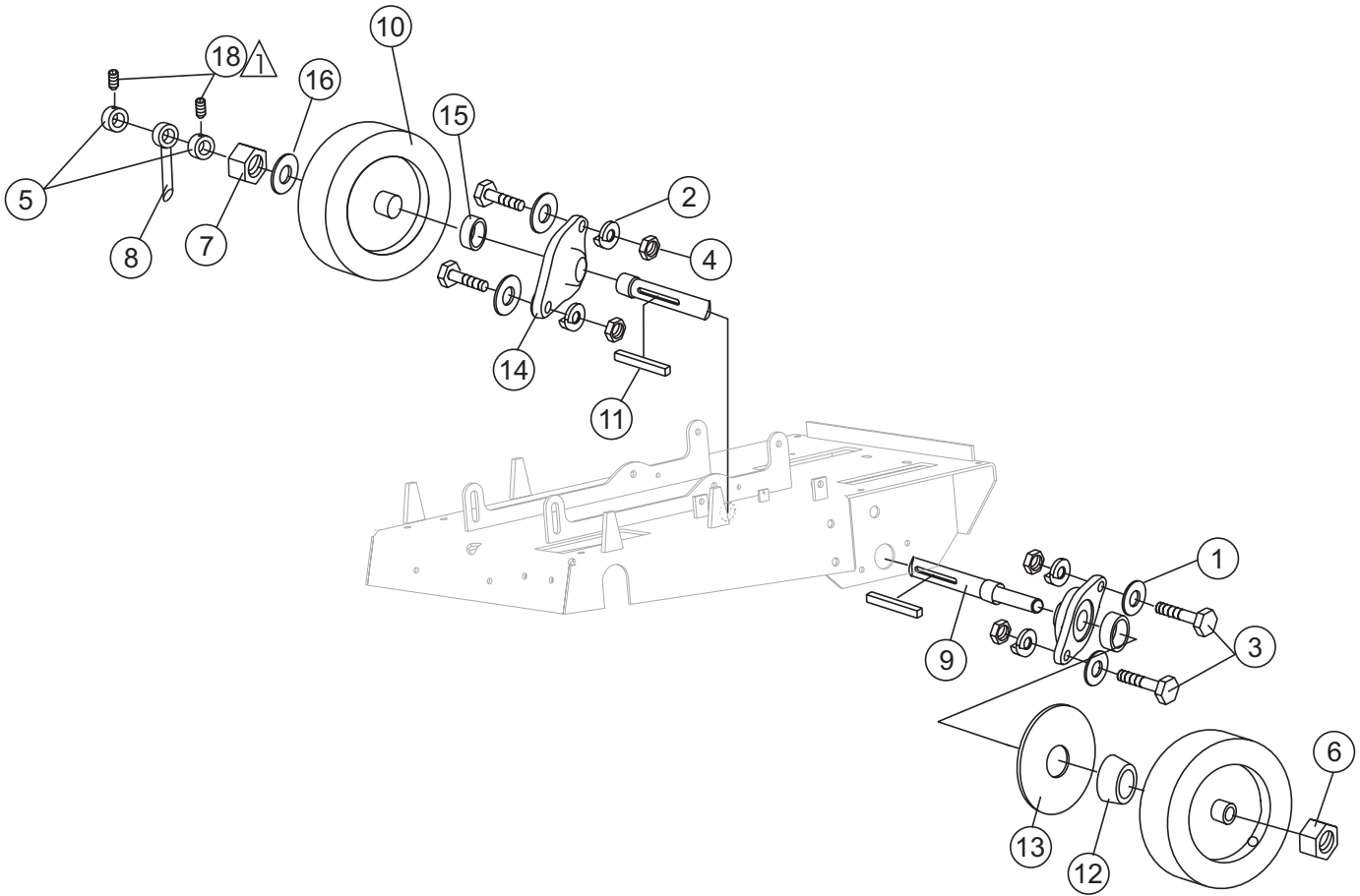

## NOTES:

 INCLUDED WITH SET COLLAR  
ITEM 5.

## FS3SP CONCRETE SAW — UNDER CARRIAGE ASSY.

### REAR AXLE ASSY.

<u>NO.</u>	<u>PART NO.</u>	<u>PART NAME</u>	<u>QTY.</u>	<u>REMARKS</u>
1	0166A	WASHER, LOCK, 3/8 MEDIUM	4	
2	10136	WASHER, FLAT, 3/8 SAE	4	
3	1284	SCREW, HHC 3/8- 16 X 1- 1/2	4	
4	1456	NUT, HEX FINISH 3/8- 16	4	
5	15028	SET COLLAR, 5/8 DIAMETER	2	
6	15092	NUT, 1- 14- 2B	1	
7	15093	NUT, 1- 14 2B- LH	1	
8	15106	POINTER, REAR, W/A	1	
9	15213	REAR AXLE SELF PROPELLED	1	
10	15278	WHEEL, REAR 10.00 X 2.50	2	
11	15279	KEY, 0.25 X 0.25 X 3.25	1	
12	15356	BUSHING, TL SH X 1	1	
13	15361	SPROCKET, TL 40TB48	1	
14	15372	BEARING, FLANGED, 1" BORE	2	
15	15417	SPACER, REAR AXLE, SPROCKET	2	
16	3264	WASHER, FLAT 1" SAE	2	
17	6059B	KEY, 1/4 SQ. X 2"	1	
18		SET SCREW	2	

# FS3SP CONCRETE SAW — BLADE SHAFT ASSY.

## BLADE SHAFT ASSY.

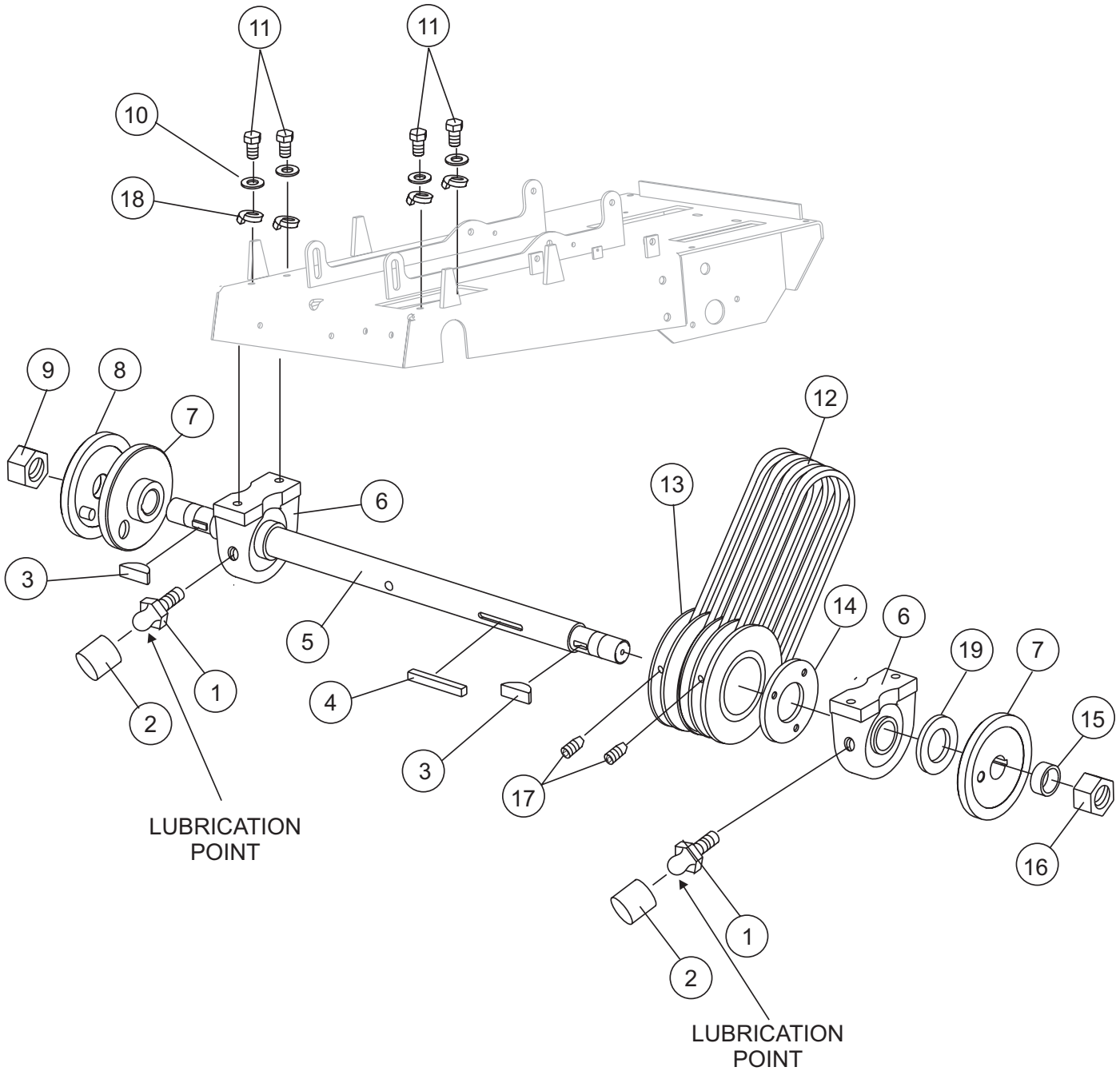

# FS3SP CONCRETE SAW — BLADE SHAFT ASSY.

## BLADE SHAFT ASSY.

NO	PART NO	PART NAME	QTY.	REMARKS
1	2621	ZERK FITTING	2	
2	1162A	CAP, ZERK FITTING	2	
3	15119	KEY, WOODRUFF #91, ANS1 #8061	2	
4	6059B	KEY, 1/4 SQ. X 2"	1	
5	15065	SHAFT, BLADE	1	
6	15066	BEARING, PILLOW BLOCK 1 1/4 BORE	2	
7	15063	FLANGE, BLADE INSIDE	2	
8	15012	FLANGE, DRIVEN ASSY.	1	
9	15093	NUT, 1-14-2B-LH	1	
10	0448	WASHER, FLAT 7 / 16 SAE	4	
11	15563	SCREW, HHC 7/16 -14 X 3/4	4	
12	10799	V-BELTS 3VX375 .....	4	20 HP ENGINE HONDA 14" BLADE
12	15897	V-BELTS 3VX355 .....	4	20 HP ENGINE HONDA 20" BLADE
13	15365	PULLEY, 4/3V4.12 X 1.125 ID/3L2.75 .....	1	20 HP ENGINE HONDA 14" BLADE
13	15366	PULLEY, 4/3V3.00 X 1.125 ID/3L2.75 .....	1	20 HP ENGINE HONDA 20" BLADE
14	15060	BUSHING, OD SDS X 1- 1/4 X 1/4	1	
15	15148	SPACER, 1.320D X 1.051D X 0.53	1	
16	15092	NUT, 1-14-2B	1	
17	1528	SCREW, SHS 1/4-20 X 5/16 HDP	2	
18	2955	WASHER, LOCK 7/16 MED	4	
19	25281	SPACER, 1.75 OD X 1.00 ID X .15	2	

# FS3SP CONCRETE SAW — ENGINE MOUNT ASSY.

ENGINE MOUNT ASSY.

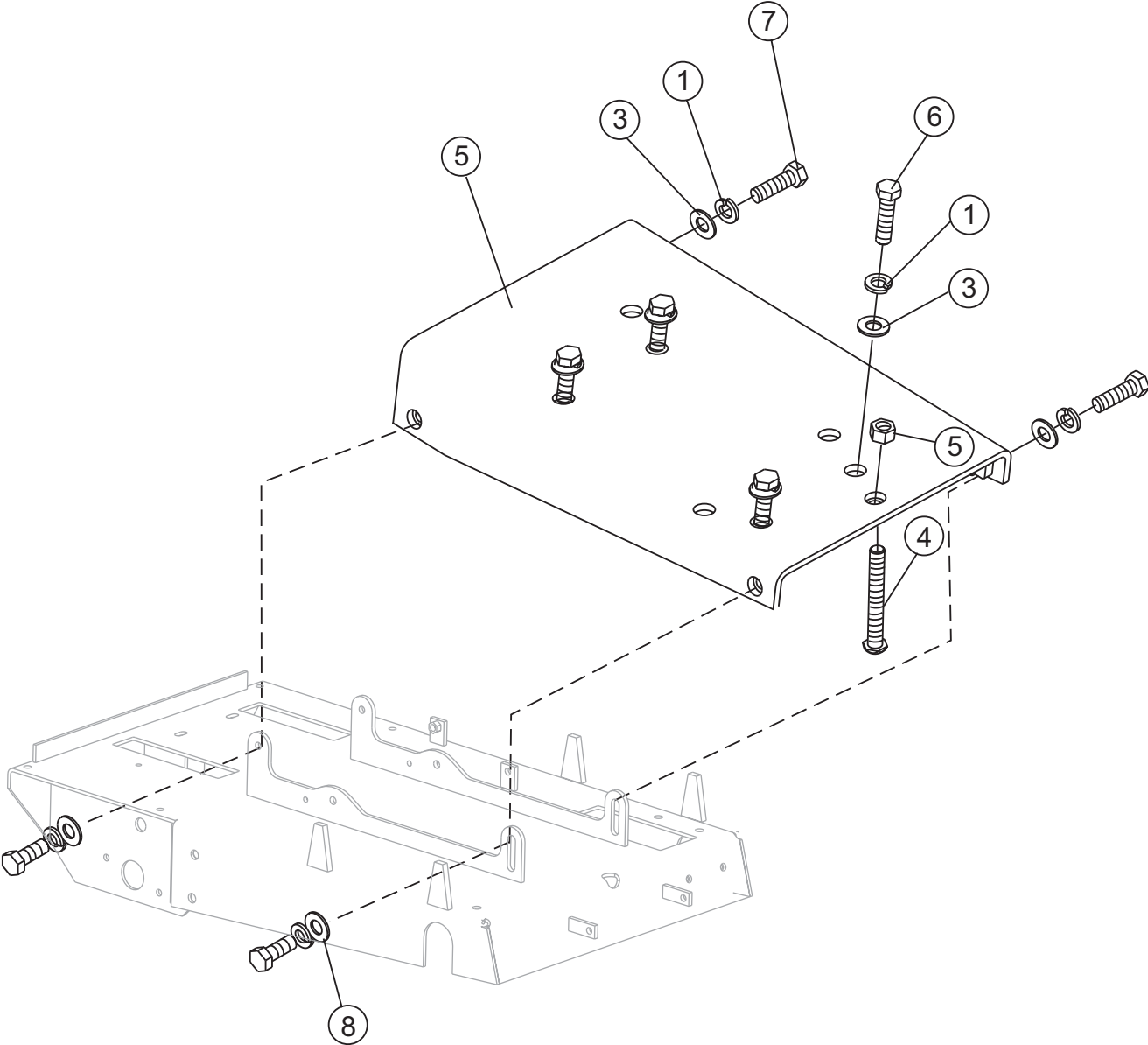



## FS3SP CONCRETE SAW — ENGINE MOUNT ASSY.

MOUNT, ENGINE ASSY.

<u>NO.</u>	<u>PART NO.</u>	<u>PART NAME</u>	<u>QTY.</u>	<u>REMARKS</u>
1	0166A	WASHER, LOCK, 3/8 MEDIUM	4	
2	1007	NUT, HEX JAM 3/8 - 16	1	
3	10136	WASHER, FLAT 3/8 SAE	6	
4	15174	BOLT, CARRIAGE 3/8- 16 X 3	1	
5	15680	MOUNT, ENGINE W/A	1	
6	1665	SCREW, HHC 3/8- 16 X 2	4	
7	25301	SCREW, HHC 3/8- 16 X 1, GRD 8	4	
8	4001	WASHER, FLAT 3/8 PLTD STD. USS	2	

# FS3SP CONCRETE SAW — POINTERS AND COVERS ASSY.

## POINTERS AND COVERS ASSY.

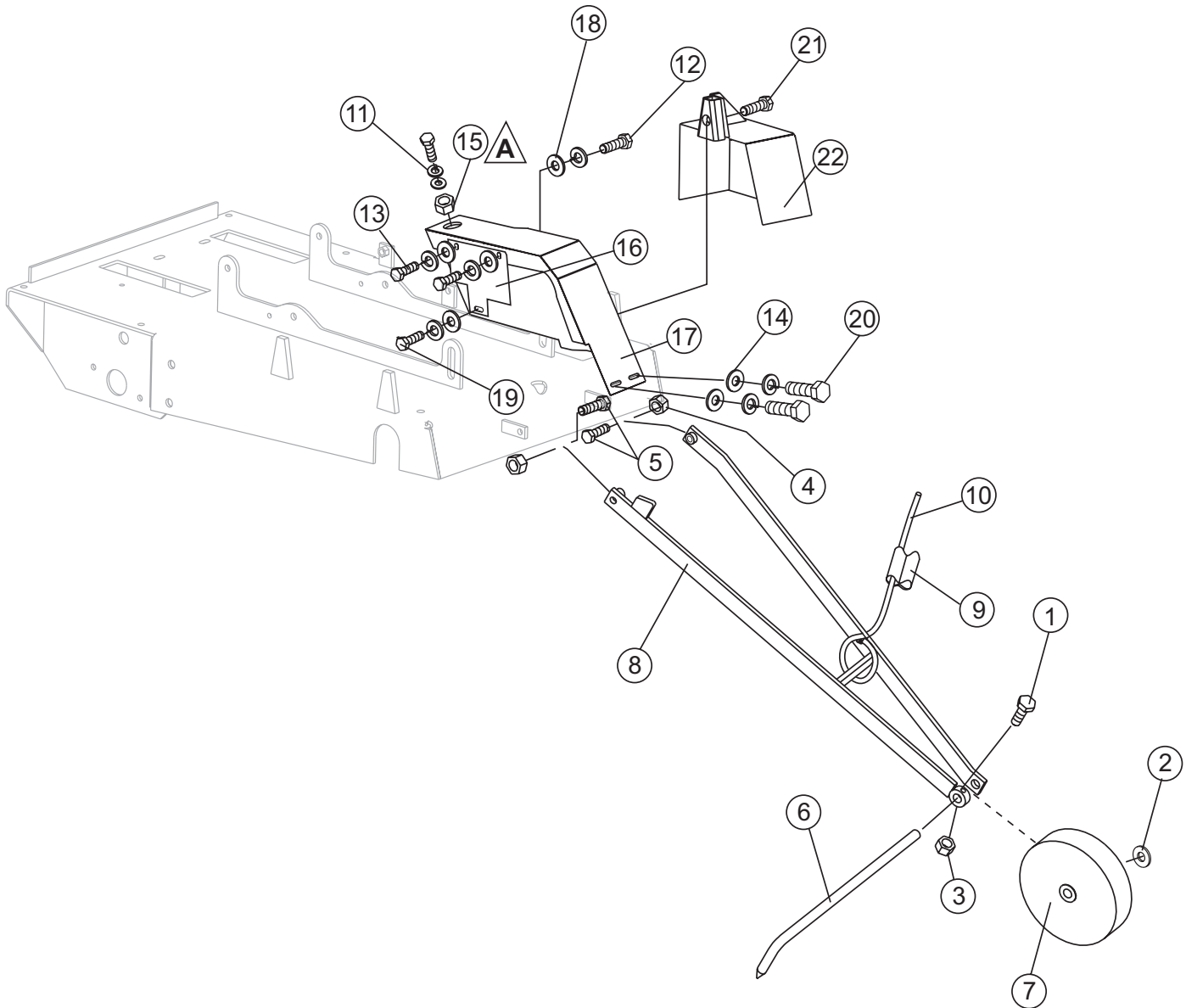

NOTES:

**A** ITEM 15 PLACED ON  
UNDERSIDE OF COVER

## FS3SP CONCRETE SAW — POINTERS AND COVERS ASSY.

### POINTER FRONT ASSY.

<u>NO.</u>	<u>PART NO.</u>	<u>PART NAME</u>	<u>QTY.</u>	<u>REMARKS</u>
1	0131A	SCREW, HHC 1/4- 20 X 3/4	1	
2	0447	WASHER, FLAT 1/2 SAE	1	
3	0949	NUT, HEX FINISH 1/4- 20	1	
4	10133	NUT, NYLOC 3/8- 16	2	
5	1023	SCREW, HHC 3/8- 16 X 1- 1/4	2	
6	15052	ROD, POINTER	1	
7	15053	WHEEL, POINTER ARM	1	
8	15889	POINTER, LONG FRONT, W/A	1	
9	15113	SASH, POINTER RETAINER	1	
10	15114	SLEEVE, SASH	1	
11	181B	WASHER, LOCK, 1/4 MEDIUM	4	
12	0205	SCREW, HHC 3/8- 16 X 1	1	
13	0948	WASHER, FLAT, 1/4 SAE	4	
14	10930	WASHER, FENDER 1/4- X 1 1/4	2	
15	11534	NUT U TYPE 1/4- 20	4	
16	15293	COVER, TRANS. BELT	1	
17	15381	COVER, BELT GUARD W/A	1	
18	4001	WASHER, FLAT 3/8 PLTD. STD. USS	1	
19	4514	SCREW, HHC 1/4- 20 X 5/8	3	
20	0131A	SCREW, HHC 1/4- 20 X 3/4	3	
21	15046	PIN, DOWEL 3/8	1	
22	15064	FLANGE, BLADE DRIVEN SIDE	1	

# FS3SP CONCRETE SAW — WATER SYSTEM ASSY.

## WATER SYSTEM ASSY.

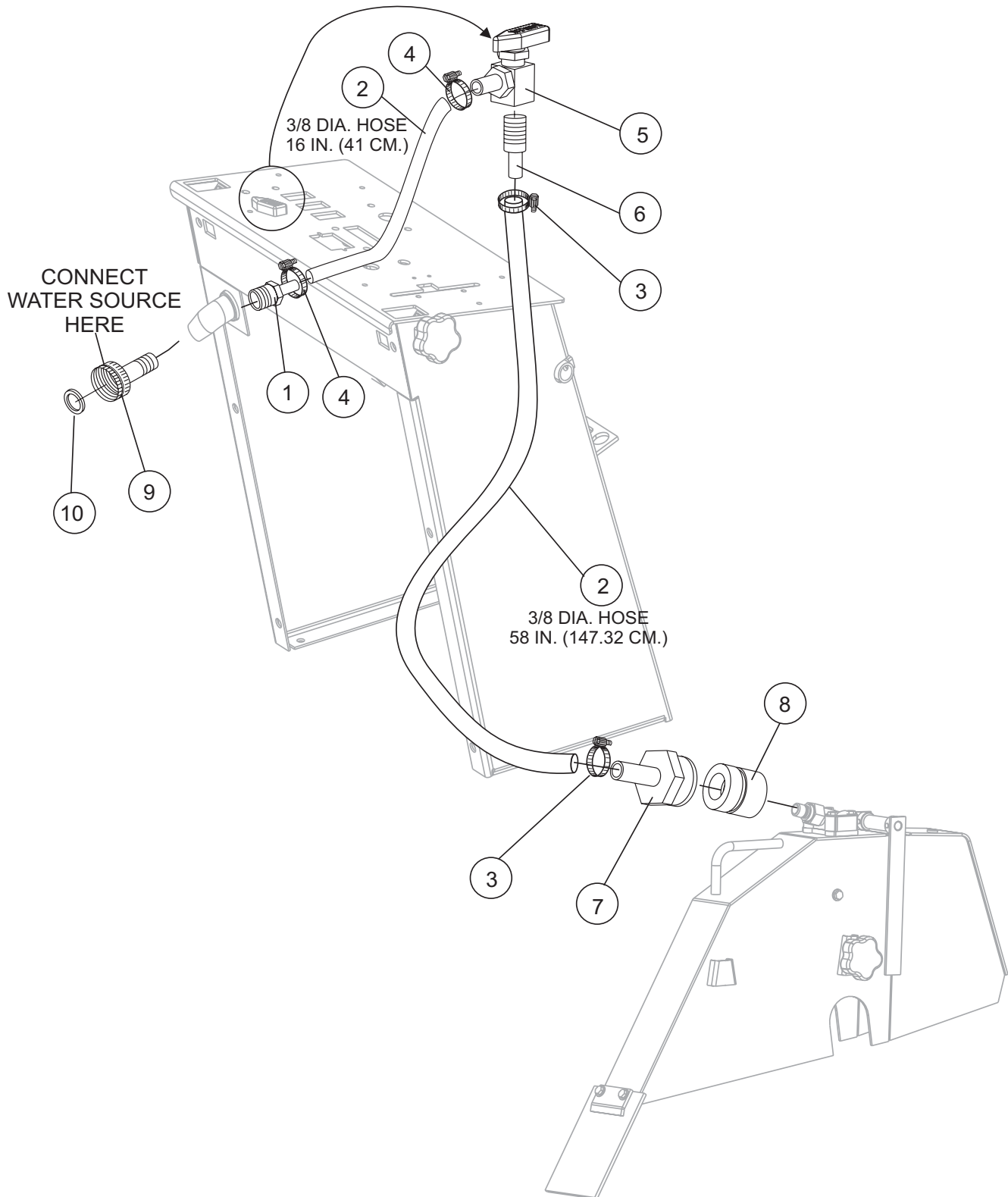

## FS3SP CONCRETE SAW — WATER SYSTEM ASSY.

FS3, WATER ASSY.

<u>NO.</u>	<u>PART NO.</u>	<u>PART NAME</u>	<u>QTY.</u>	<u>REMARKS</u>
1	15180	FITTING, STR 6 BARB- 1/2 MP	1	
2	15181	HOSE, 3/8 BLACK WATER 200PSI	5.5	
3	15538	CLAMP, WORM HOSE, 7/16- 11/16	4	
4	15546	GASKET, 3/4 HOSE GASKET/SCREEN	1	
5	15766	VALVEL, 2 WAY 3/8 BARB X 3/8 MPT	1	
6	15767	FITTING, 6FPT- 6BARB	1	
7	15768	FITTING, 6BARB 3/4 MALE HOSE	1	
8	15769	FITTING, 3/4 HOSE QUICK REL. FEMALE	1	
9	15546	GASKET, 3/4 HOSE GASKET / SCREEN	1	
10	15076	FITTING, STR 3/4 FEM HOSE X 1/2 MP	1	

# FS3SP CONCRETE SAW — BASIC PLATFORM ASSY.

## BASIC PLATFORM ASSY.

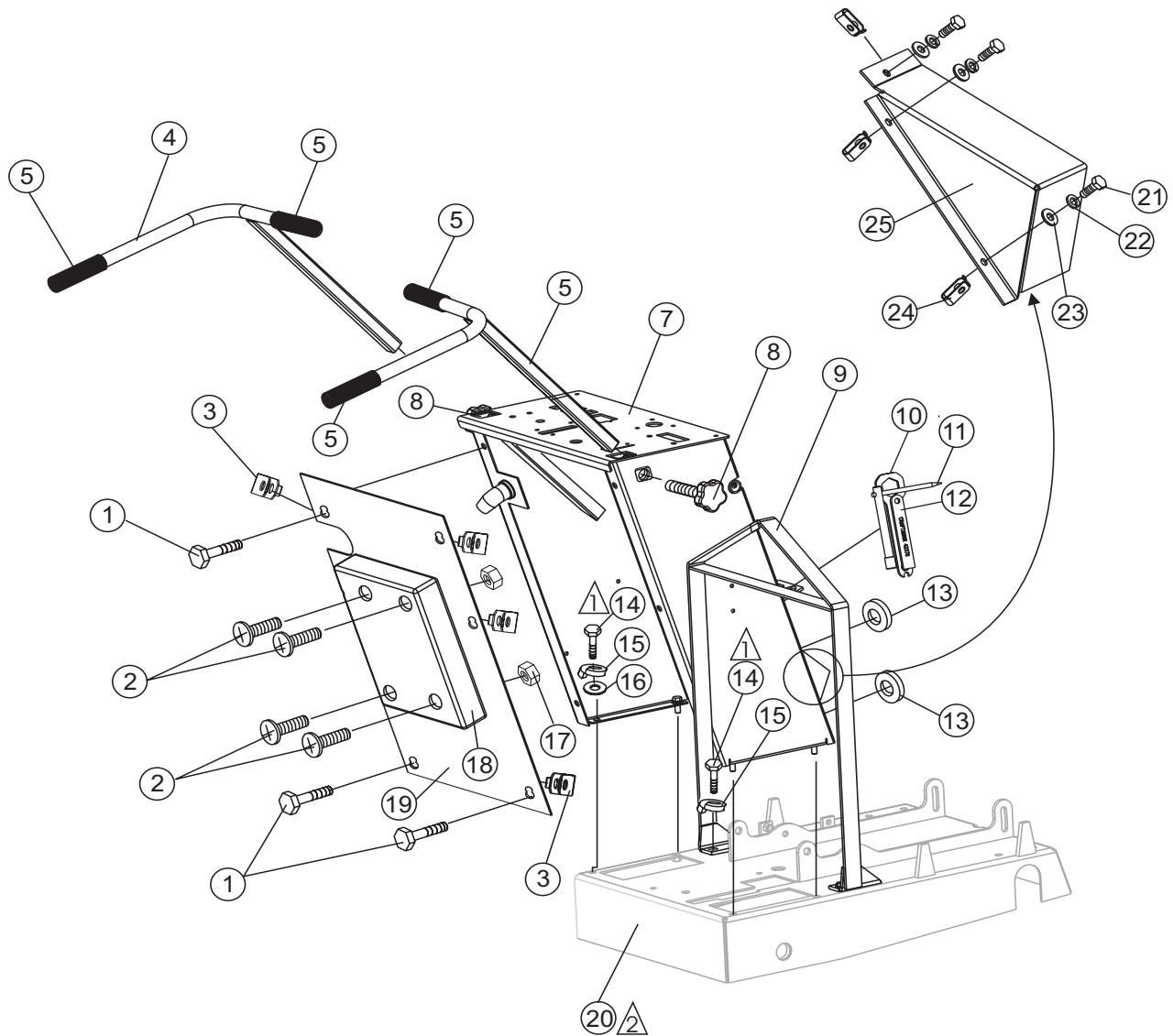

### NOTES:

▲ USE LOCTITE 271 ON ITEM 13, SCREW, HHC 3/8-16 X 1

▲ REFERENCE PAGES 66 AND 67 FOR COMPLETE PARTS BREAK-DOWN FOR BARE PLATFORM ASSY. P/N 15409.

# FS3SP CONCRETE SAW — BASIC PLATFORM ASSY.

## COVER ASSY., REAR

<u>NO.</u>	<u>PART NO.</u>	<u>PART NAME</u>	<u>QTY.</u>	<u>REMARKS</u>
1	0916	SCREW, RHM 1/4- 20- X 3/4	4	
2	10024	NUT, NYLOC 1/4- 20	4	
3	11534	NUT U TYPE 1/4- 20	6	
4	11819	SCREW, HHC, WASHER 1/4- 20 X 3/4	6	
5	15266	COVER, REAR	1	
6	29057	DOCUMENT BOX, (CP90007-07)	1	
7	15081	HANDLE, 1" DIAMETER	2	
8	15701	HANDLEBAR, LEFT W/A	1	
9	15081	HANDLE, 1" DIAMETER	2	
10	15702	HANDLEBAR, RIGHT W/A	1	
11	15212	CONSOLE W/A FS3	1	
12	15505	KNOB, COMFORT GRIP	2	
13	0166	SCREW, HHC 3/8- 16 X 7/8	4	
14	10133	NUT, NYLOC 3/8- 16	6	
15	10136	WASHER, FLAT 3/8 SAE	11	
16	16524	SCREW, HHC 1/2- 13 X 1- 1/4	4	
17	5054A	WASHER, LOCK, 1/2 MEDIUM	4	
18	15703	BALE, LIFT W/A	1	
19	15097	WRENCH, ALL PURPOSE	1	
20	15098	TOOL, SHAFT LOCK SOCKET W/A	1	
21	15138	WRENCH, 6" POCKET SOCKET	1	
22	0131A	SCREW, HHC 1/4- 20 X 3/4	4	
23	0181B	WASHER, LOCK, 1/4 MED.	4	
24	0948	WASHER, FLAT, 1/4 SAE	4	
25	15398	COVER, CHAIN GUARD	1	

# FS3SP CONCRETE SAW — BLADE MIST 20 -INCH ASSY.

BLADE MIST 20-INCH ASSY.

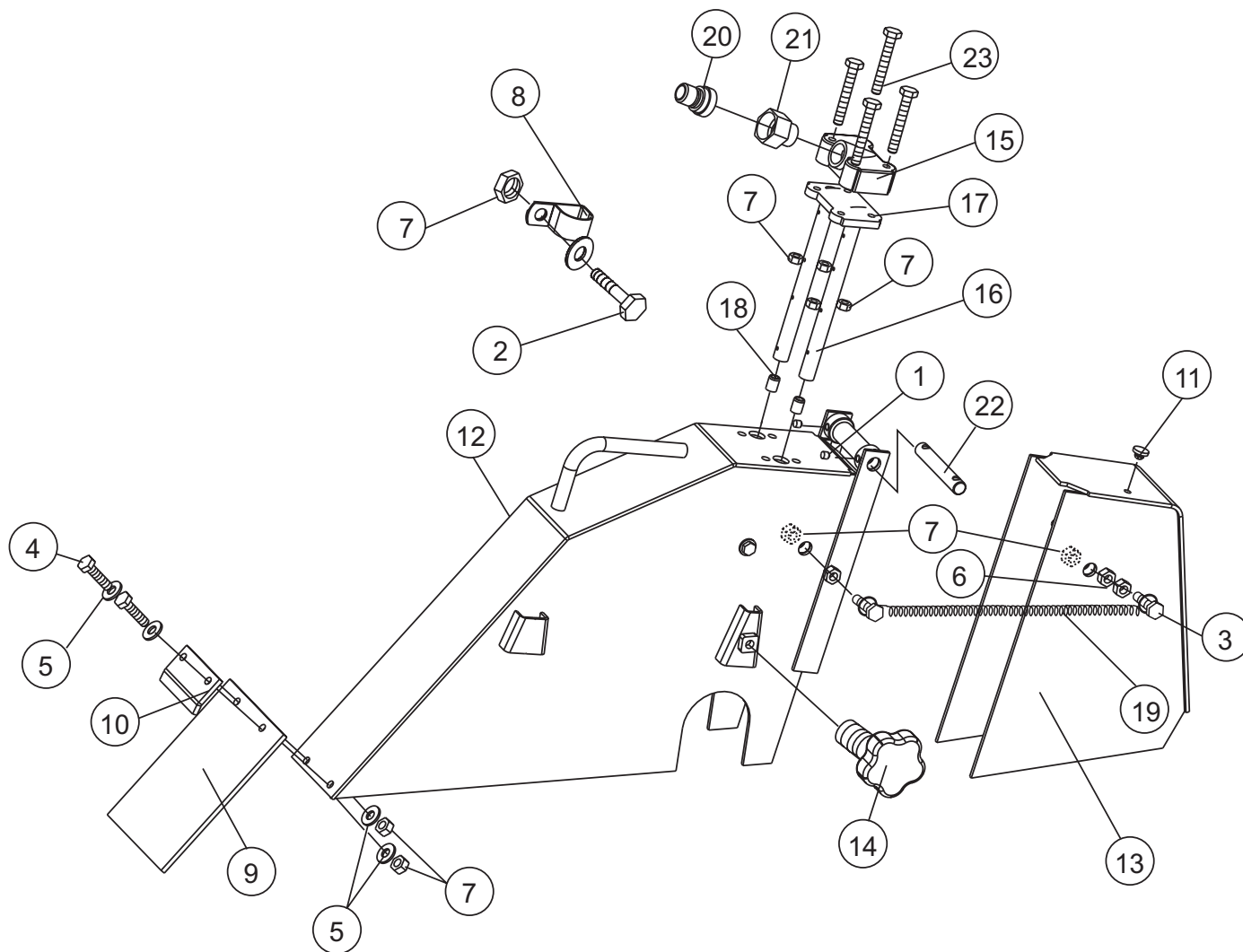



## FS3SP CONCRETE SAW — BLADE MIST 20 -INCH ASSY.

GUARD, BLADE 20" ASSY.

<u>NO.</u>	<u>PART NO.</u>	<u>PART NAME</u>	<u>QTY.</u>	<u>REMARKS</u>
1	0130A	SCREW, SHS 1/4- 20 X 1/4	2	
2	0131A	SCREW, HHC 1/4- 20 X 3/4	2	
3	0424	SCREW, HHC 1/4- 20 X 1 1/4	2	
4	0730	SCREW, HHC 1/4- 20 X 1	2	
5	0948	WASHER, FLAT 1/4 SAE	6	
6	0949	NUT, HEX FINISH 1/4- 20	4	
7	10024	NUT, NYLOC 1/4- 20	10	
8	11505	CLAMP, HOSE SUPPORT 1/2 INCH LONG	2	
9	15043	FLAP, NEOPRENE WATER SHIELD	1	
10	15096	ANGLE, SPLASH GUARD	1	
11	15161	STOP, RUBBER BUMPER	1	
12	15462	GUARD BLADE 20" BODY W/A	1	
13	15463	GUARD BLADE 20" DOOR W/A	1	
14	15503	KNOB, CONFORT GRIP	1	
15	15504	MANIFOLD, (CIPSA)	1	
16	15506	TUBE, FLOOD	2	
17	15507	GASKET, MANIFOLD FLOOD	1	
18	15508	PLUG (CIPSA)	2	
19	15509	SPRING, CENTURY SPRING #	1	
20	15770	FITTING, 3/4 HOSE QUICK REL. MALE	1	
21	15842	FITTING, 1/2MP- 3/4 F HOSE	1	
22	25023	PIN, HINGE- 1/2 X 3.22	1	
23	26250	SCREW, HHC 1/4- 20 X 1- 3/4	4	

# FS3SP CONCRETE SAW — MANUAL RAISE AND LOWER ASSY.

MANUAL RAISE AND LOWER ASSY.

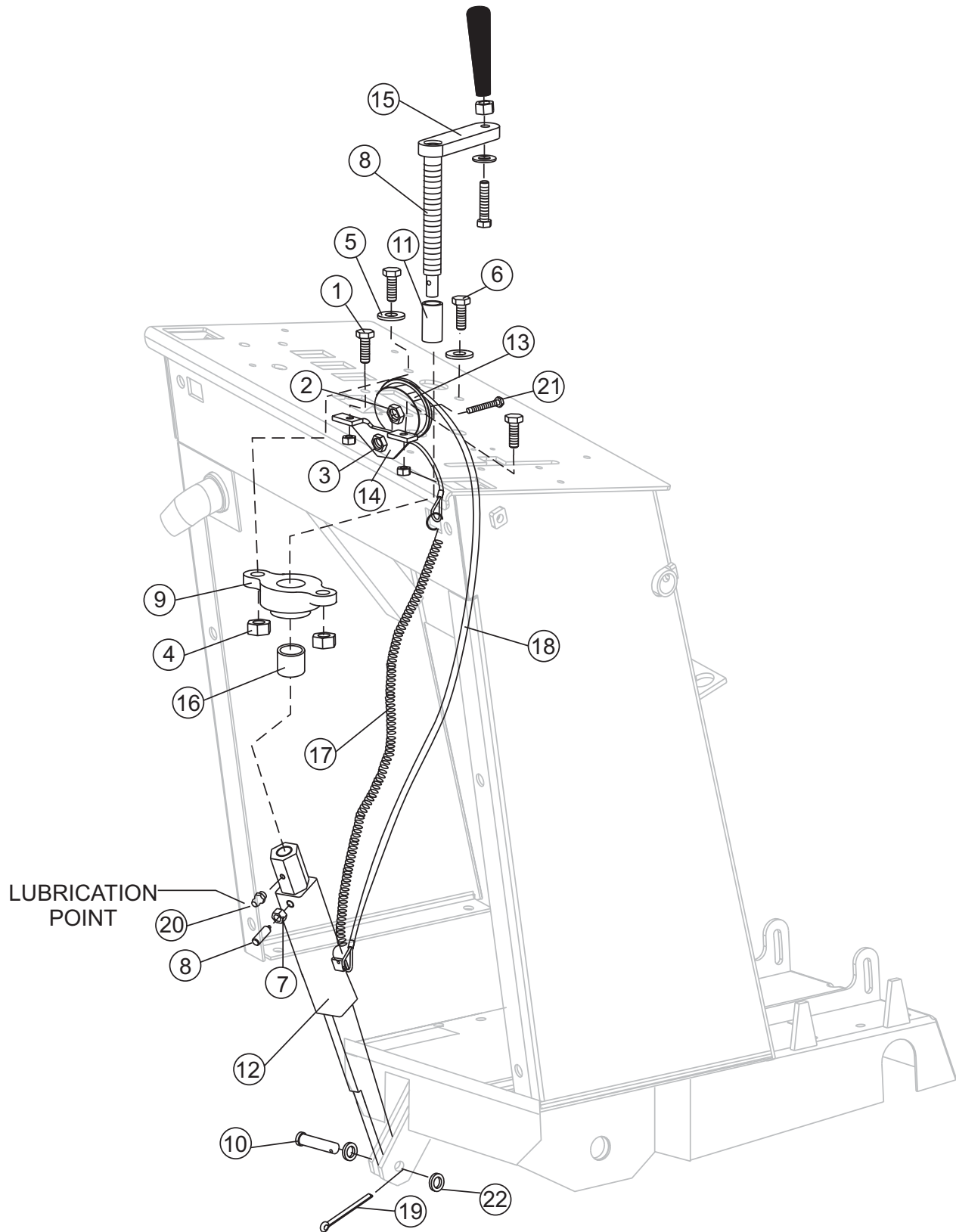

# FS3SP CONCRETE SAW — MANUAL RAISE AND LOWER ASSY.

## MANUAL LIFT ASSY.

<u>NO.</u>	<u>PART NO.</u>	<u>PART NAME</u>	<u>QTY.</u>	<u>REMARKS</u>
1	0131A	SCREW, HHC 1/4- 20 X 3/4	2	
2	0949	NUT, HEX FINISH 1/4- 20	1	
3	10024	NUT, NYLOC 1/4 - 20	3	
4	10133	NUT, NYLOC 3/8- 16	2	
5	10136	WASHER, FLAT 3/8 SAE	2	
6	1023	SCREW, HHC 3/8- 16 X 1- 1/4	2	
7	1456	NUT, HEX FINISH 3/8- 16	1	
8	15054	PLUNGE, BALL	1	
9	15080	BEARING, DEPTH GAUGE	1	
10	15083	PIN, HEADED BLADE ADJUST	1	
11	15089	SPACER, DEPTH, ADJUSTER	1	
12	15206	LOWER ARM W/A, DEPTH CONTROL	1	
13	15704	GAUGE, DEPTH	1	
14	15708	BRACKET, DEPTH GAUGE	1	
15	15710	HANDLE, MANUAL R/ L ASSEMBLY	1	
16	15712	SPACER, 1" OD X 0.77" ID X 1.31" L	1	
17	15717	SPRING, EXTENSION 5L X 0.25D X .038d	1	
18	15738	CABLE ASSEMBLY DEPTH GAUGE	1	
19	2219	PIN, COTTER 1/8 X 1- 1/2	1	
20	2621	ZERK, GREASE STR. 1/4- 28	1	
21	26385	SCREW, HHC 1/4- 20 X 1/4 GRD. 8	1	
22	8151	WASHER, FLAT 3/4 SAE	2	

# FS3SP CONCRETE SAW — PLUG KIT (PUSH) ASSY.

PLUG KIT (PUSH) ASSY.

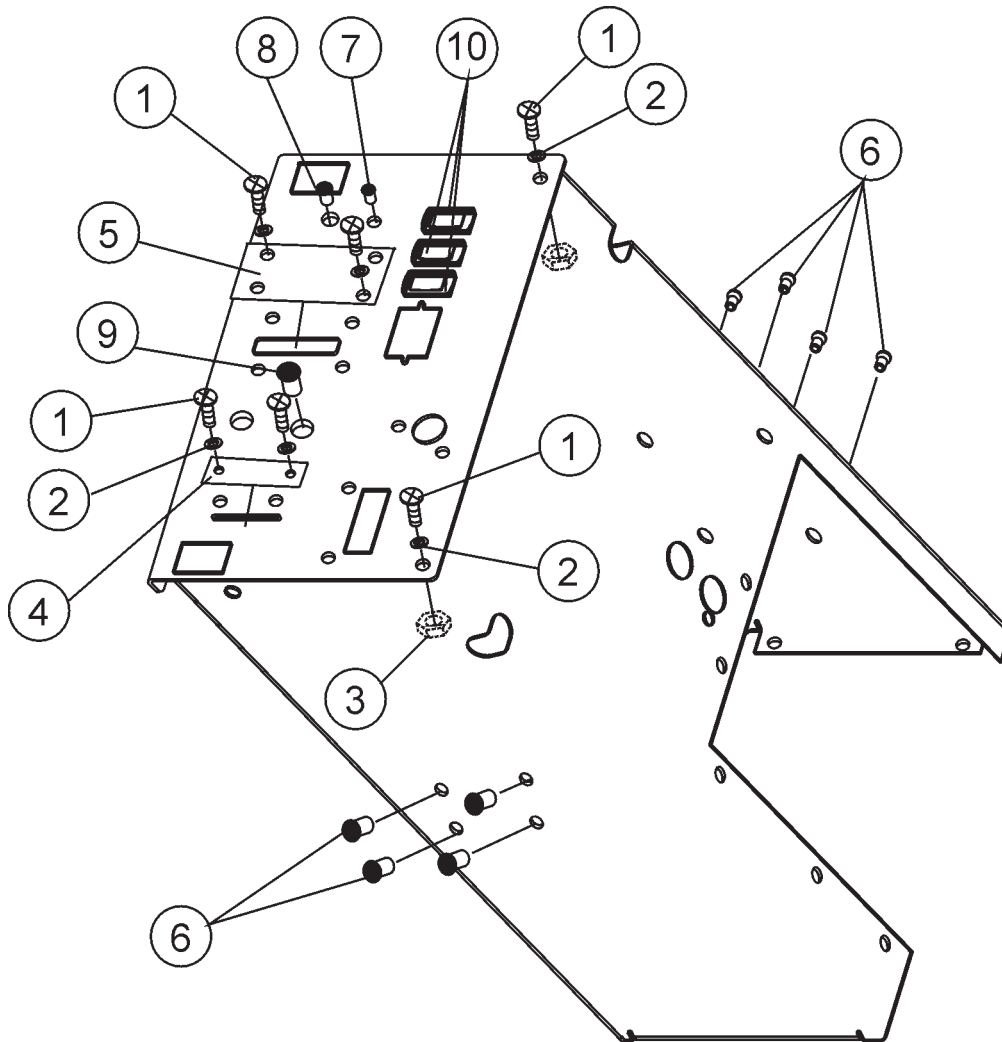

## FS3SP CONCRETE SAW — PLUG KIT (PUSH) ASSY.

### PLUG KIT (PUSH) ASSY.

NO	PART NO	PART NAME	QTY.	REMARKS
1	0916	SCREW, HHC RHM 1/4-20 X 3/4	8	
2	0948	WASHER, FLAT	8	
3	10024	NUT, NYLOC 1/4-20	8	
4	15208	COVER, PROPEL LEVEL FS2	1	
5	15339	COVER, FS2 ENGAGE HOLE	1	
6	15340	PLUG, 0.65 DIA X 14 GA, BLACK	8	
7	15341	PLUG, 0.44 DIA X 14 GA, BLACK	1	
8	15342	PLUG, 0.38 DIA X 14 GA, BLACK	1	
9	15345	PLUG, 0.28 DIA X 14 GA, BLACK	1	
10	15553	SWITCH, BLANK	3	

# FS3SP CONCRETE SAW — PLUG KIT (SELF PROPELLED) ASSY.

PLUG KIT (SELF PROPELLED) ASSY.

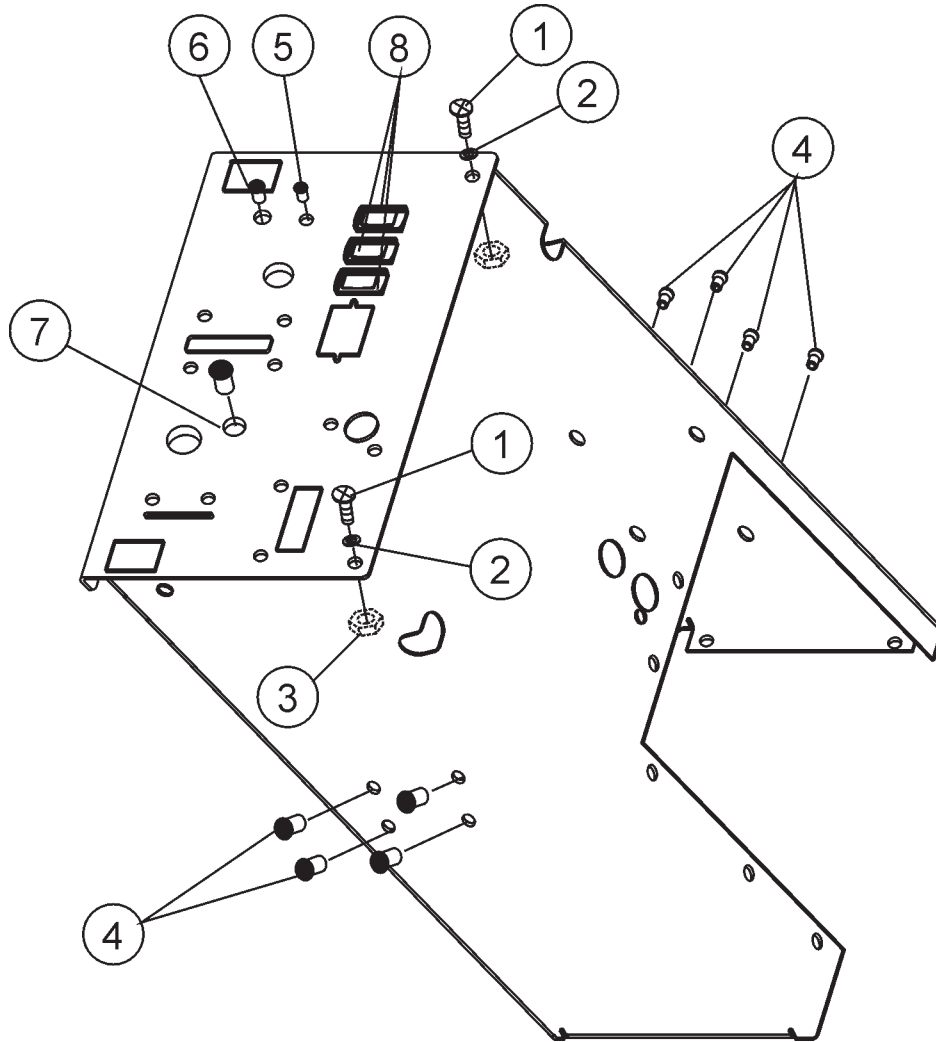

# FS3SP CONCRETE SAW — PLUG KIT (SELF PROPELLED) ASSY.

## PLUG KIT (SELF PROPELLED) ASSY.

NO	PART NO	PART NAME	QTY.	REMARKS
1	0916	SCREW, HHC RHM 1/4-20 X 3/4	2	
2	0948	WASHER, FLAT	2	
3	10024	NUT, NYLOC 1/4-20	2	
4	15340	PLUG, 0.65 DIA X 14 GA, BLACK	8	
5	15341	PLUG, 0.44 DIA X 14 GA, BLACK	1	
6	15342	PLUG, 0.38 DIA X 14 GA, BLACK	1	
7	15345	PLUG, 0.28 DIA X 14 GA, BLACK	1	
8	15553	SWITCH, BLANK	3	

# FS3SP CONCRETE SAW — BATTERY BOX ASSY.

## BATTERY BOX ASSY.

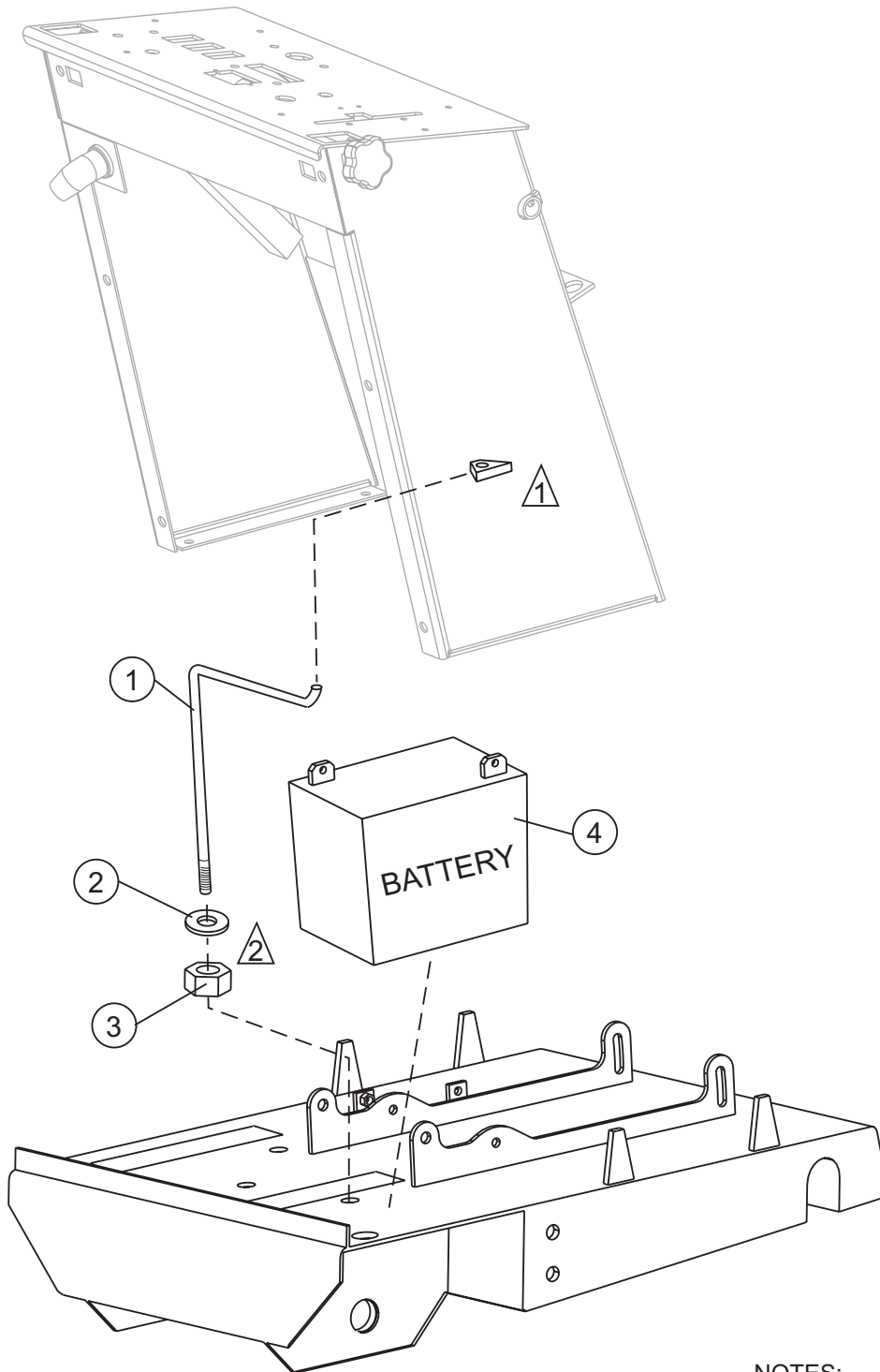

### NOTES:

- ① BRACKET IS ON INSIDE OF CONSOLE CHASSIS
- ② ITEMS 2 AND 3 ARE ATTACHED ON THE UNDERSIDE OF THE PLATFORM



# FS3SP CONCRETE SAW — BATTERY BOX ASSY.

## BATTERY BOX ASSY.

NO	PART NO	PART NAME	QTY.	REMARKS
1	15203	BATTERY HOLD DOWN	1	
2	0948	WASHER, FLAT 1/4" SAE	1	
3	10024	NUT, NYLOCK 1/4 - 20	1	
4	0471	BATTERY, WET GR.U1	1	

# FS3SP CONCRETE SAW — PLATFORM (BARE) ASSY.

PLATFORM (BARE) ASSY.

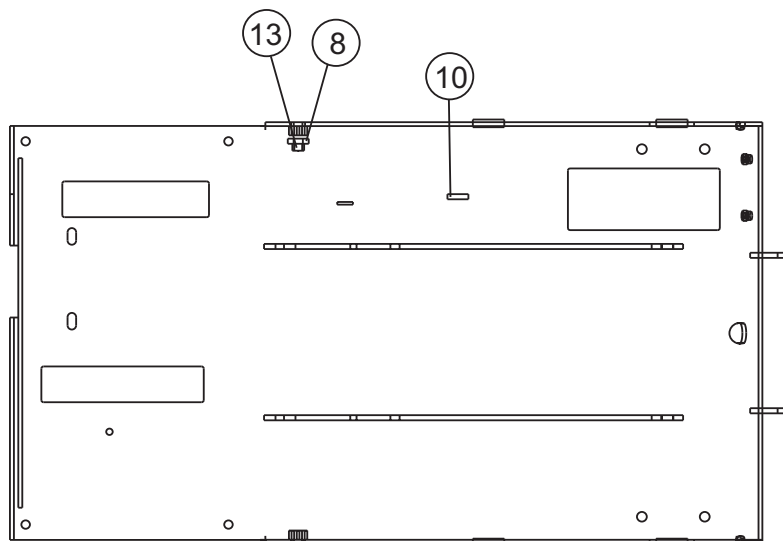

TOP VIEW

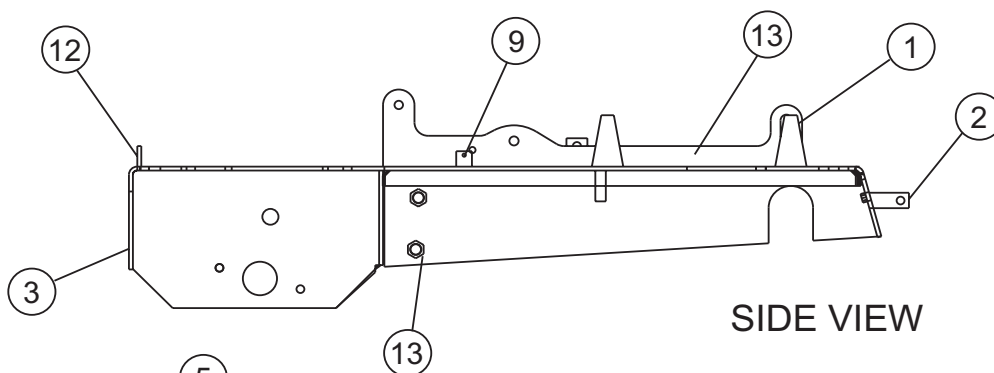

SIDE VIEW

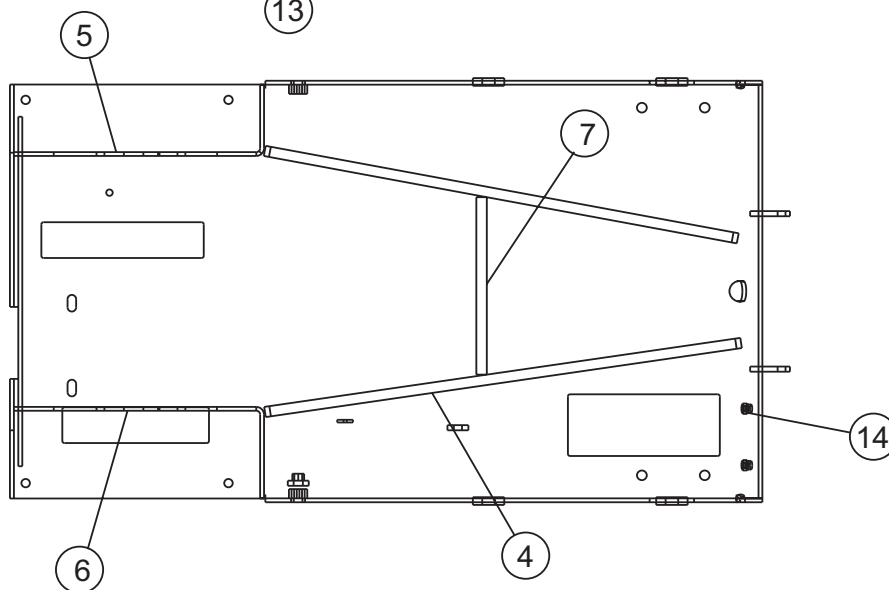

BOTTOM VIEW

# FS3SP CONCRETE SAW — PLATFORM (BARE) ASSY.

## PLATFORM (BARE) ASSY.

NO	PART NO	PART NAME	QTY.	REMARKS
1	15035	MOUNT, BLADE GUARD BAYONET	4	
2	15069	MOUNT, FRONT POINTER	4	
3	15214	PLATFORM	1	
4	15215	SUPPORT, PLATFORM	2	
5	15373	SUPPORT, REAR AXLE RIGHT	1	
6	15374	SUPPORT, REAR AXLE LEFT	1	
7	15428	SUPPORT, CROSS PLATFORM	1	
8	15453	PLATE, MOUNT, BELT COVER	1	
9	15455	TAB, SPRING IDLER	1	
10	15672	TAB, IDLER MOUNT	1	
11	15682	MOUNT, ENGINE / TRANS SIDE	2	
12	15742	STIFFENER, REAR PLATFORM	1	
13	20530	NUT, WELD, HEX LOCK 3/8-16	1	
14	20533	NUT, WELD, HEX LOCK 1/4-20	2	
15	968011	NUT, HEX FINISH 1/2-13	4	

# FS3SP CONCRETE SAW — TRANSMISSION ASSY.

## TRANSMISSION ASSY.

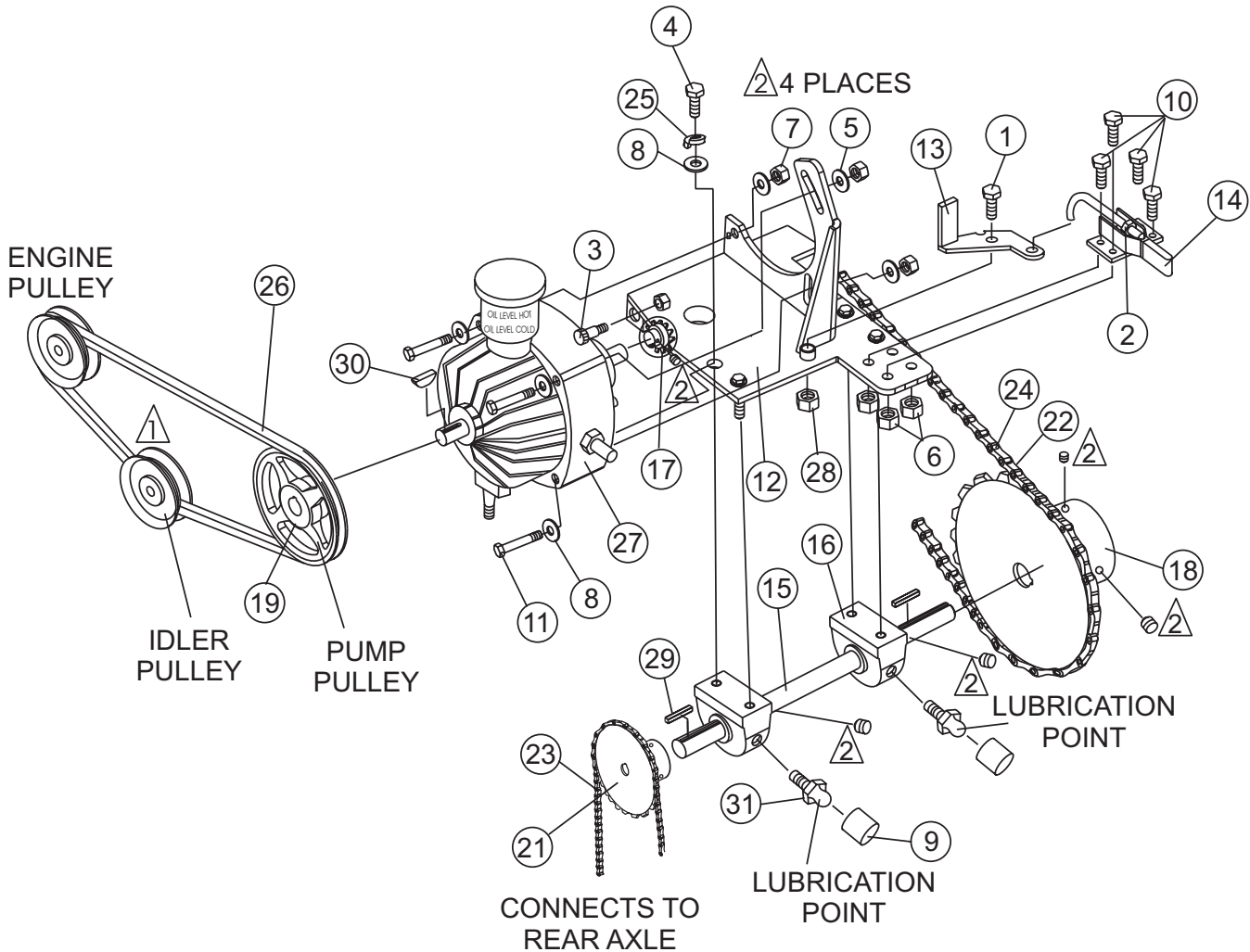

### NOTES:

- ⚠ **DO NOT OVER TIGHTEN.** IDLER PULLEY SHOULD BE FREE TO MOVE.
- ⚠ USE LOCTITE P/N 60091 (BLUE).
- ⚠ THROTTLE CABLE INCLUDED WITH HANDLE.

# FS3SP CONCRETE SAW — TRANSMISSION ASSY.

## HYDROSTATIC DRIVE ASSY.

<u>NO.</u>	<u>PART NO.</u>	<u>PART NAME</u>	<u>QTY.</u>	<u>REMARKS</u>
1	0105	SCREW, HHC 5/16- 18 X 1 1/2	1	
2	0161D	NUT, HEX FINISH 5/16- 18	1	
3	0166	SCREW, HHC 3/8- 16 X 7/8	6	
4	0205	SCREW, HHC 3/8- 16 X 1	4	
5	0300B	WASHER, FLAT 5/16 SAE	1	
6	10019	NUUT, NYLOC 10- 32	4	
7	10133	NUT, NYLOC 3/8- 16	7	
8	10136	WASHER, FLAT 3/8 SAE	20	
9	1162A	CAP, GREASE ZERK #2	2	
10	11644	SCREW, HHC, WASHER 10- 32 X 5/8	4	
11	1493	SCREW, HHC 3/8- 16 X 3- 1/4	3	
12	15288	MOUNT, TRANSMISSION, W/A	1	
13	15300	DISENGAGE LEVER, W/A	1	
14	15301	DISENGAGE, LATCH CLAMP	1	
15	15355	SHAFT, REDUCTION, TRANS.	1	
16	15359	BEARING, PIL. BLK., BRN. VTBS- 212	2	
17	15360	SPROCKET, 40BS10 X 17MM X 1/8	1	
18	15361	SPROCKET, TL 40TB48	1	
19	15363	SHEAVE, TL 1/3V106(3.35)	1	
20	15371	MOUNT, DRIVE SYSTEM	2	
21	15379	SPROCKET, 40BS10 X 3/4 X 3/16	2	
22	15389	CHAIN, ROLLER #40S X 57P	1	
23	15390	CHAIN, ROLLER #40S X 63P	1	
24	15391	CONNECTOR LINK #40 CHAIN	2	
25	0166A	WASHER, LOCK 3/8 MED	4	
26	15432	BELT, 3L ACCU- LINK WITH INSTRUCTION SHEET	1	
27	25040	TRANSMISSION, EATON MODEL 700- 001	1	
28	29096	NUT, HEX 5/16- 18 PLAIN	1	
29	0627	KEY, SQUARE 3/16 x 1-1/4	2	
30	1578	KEY, WOODRUFF #3	1	
31	2621	ZERK FITTING	2	

# FS3SP CONCRETE SAW — TRANSMISSION ASSY.

HYDROSTATIC THROTTLE ASSY.

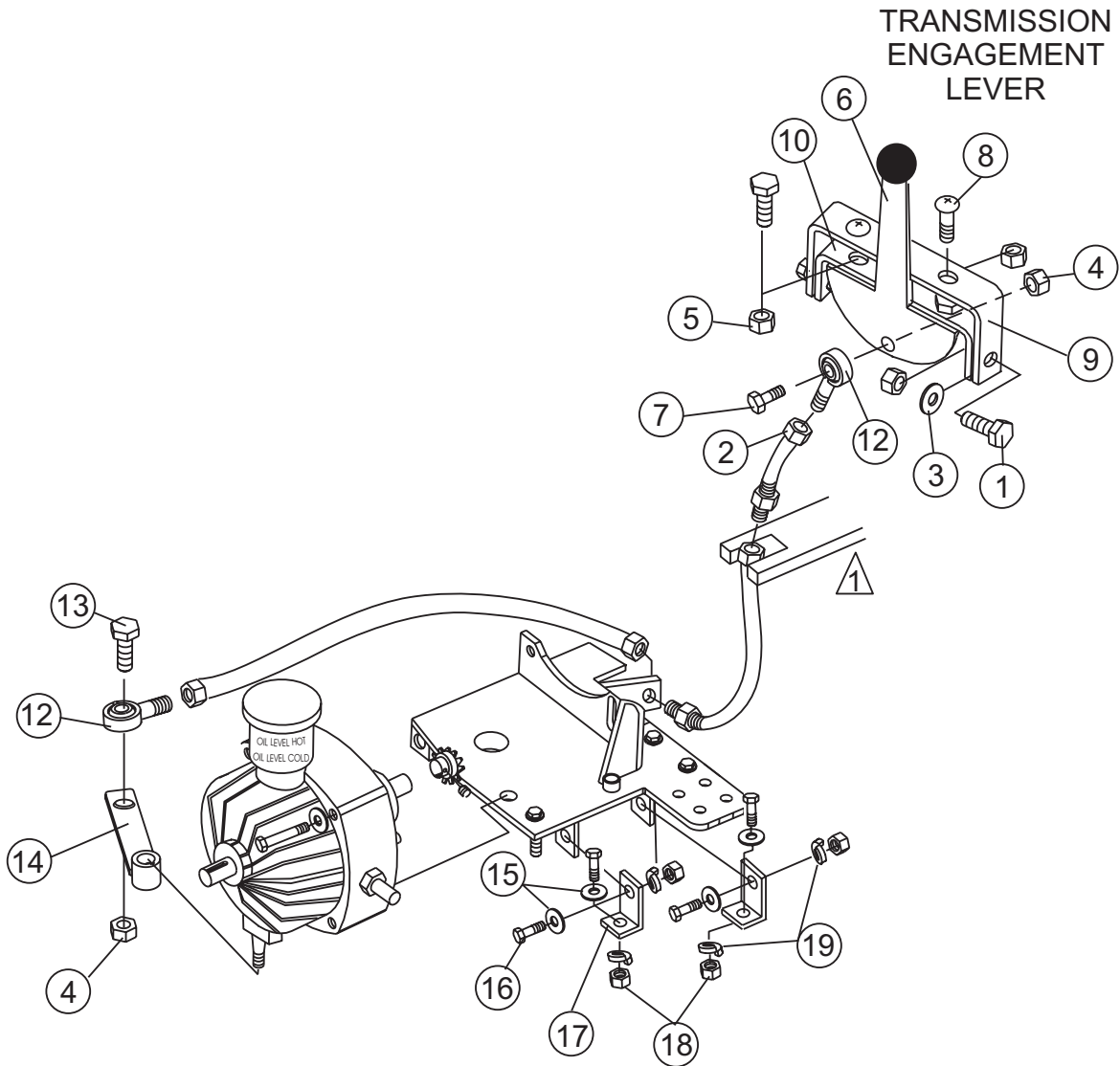

NOTES:

△ 1 BRACKET FOUND ON RIGHT SIDE  
OF CONSOLE INTERIOR

# FS3SP CONCRETE SAW — TRANSMISSION ASSY.

## HYDROSTATIC THROTTLE ASSY.

<u>NO.</u>	<u>PART NO.</u>	<u>PART NAME</u>	<u>QTY.</u>	<u>REMARKS</u>
1	0131A	SCREW, HHC 1/4- 20 X 3/4	4	
2	0937	NUT, HEX #10- 32	2	
3	0948	WASHER, FLAT, 1/4 SAE	2	
4	10019	NUT, NYLOC 10- 32	2	
5	10024	NUT, NYLOC 1/4- 20	4	
6	11379	LEVER, THROTTLE	1	
7	11644	SCREW, HHC, WASHER 10- 32 X 5/8	1	
8	12287	SCREW, THP 1/4- 20 X 3/4 SS	2	
9	15773	BRACKET, UPR PVT FLOW CONTROL	1	
10	15774	BRACKET, LWR PVT FLOW CONTROL	1	
11	15789	CABLE, THROTTLE 314VTT- 2- 30 1/4	1	
12	2153	ROD END, 10- 32 FEMALE RH	2	
13	3513	SCREW, HHC 10- 32 X 1	1	
14	15395	CONTROL, PUMP W/A	1	
15	10136	WASHER, FLAT 3/8 SAE	4	
16	0166	SCREW, HHC 3/8- 16 X 7/8	4	
17	15371	MOUNT, DRIVE SYSTEM	2	
18	10133	NUT, NYLOC 3/8- 16	4	
19	0166A	WASHER, LOCK 3/8 MED	4	

# FS3SP CONCRETE SAW — ENGINE ASSY.

ENGINE ASSY.

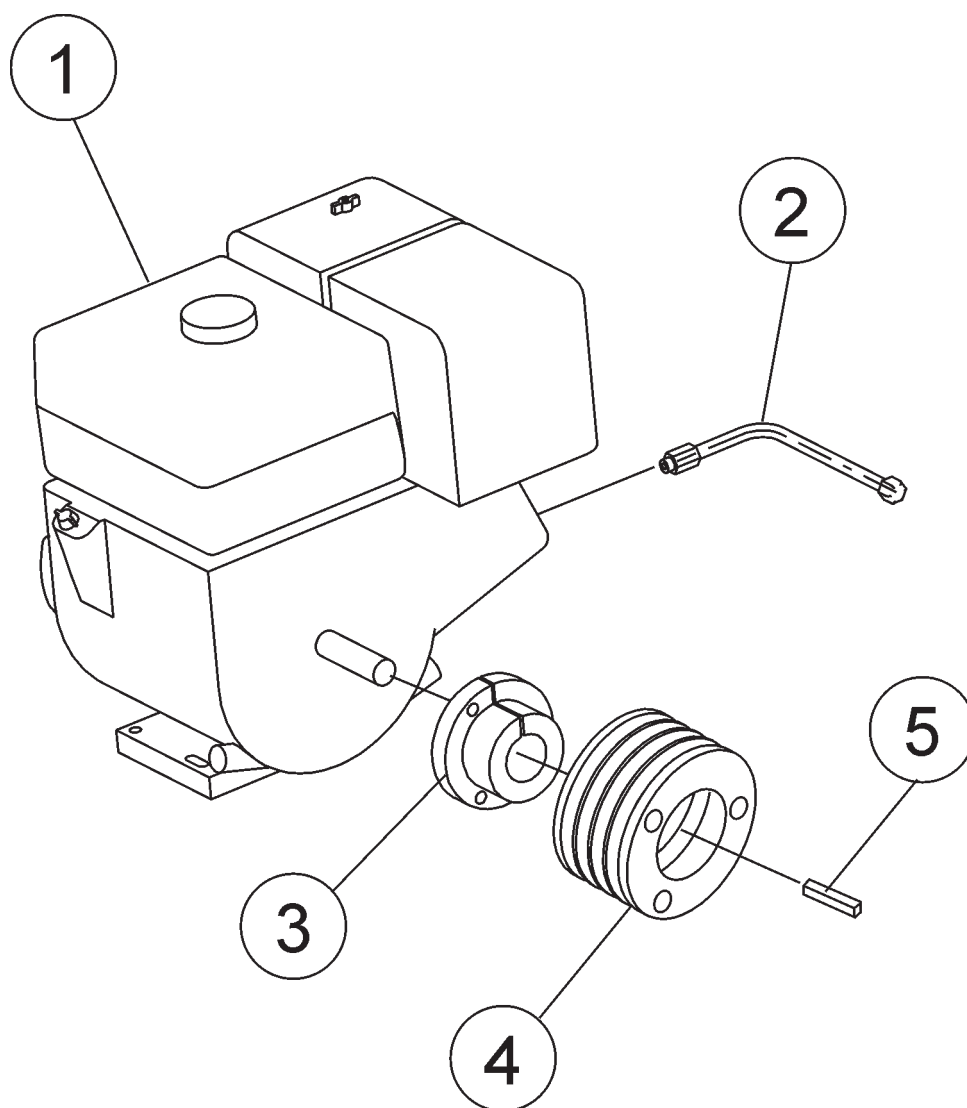



# FS3SP CONCRETE SAW — ENGINE ASSY.

## ENGINE ASSY.

<u>NO</u>	<u>PART NO</u>	<u>PART NAME</u>	<u>QTY.</u>	<u>REMARKS</u>
1	15729	ENGINE, KOHLER 20 HP W/CHARGE	1	
1	15104	ENGINE, HONDA 20HP GX620TXF2	1	
2	15743	TUBE, OIL DRAIN ASSY.	1	
3	15386	BUSHING, TL 1.125" BORE	1	
4	15769	PULLEY, 1.75TL 4/3V 3.00OD	1	
5	6059B	KEY, 1/4"SQ. X 2"	1	



# FS3SP CONCRETE SAW — WIRING DIAGRAM.

## FS3SP ELECTRIC START WIRING DIAGRAM (ROCKER SWITCHES)

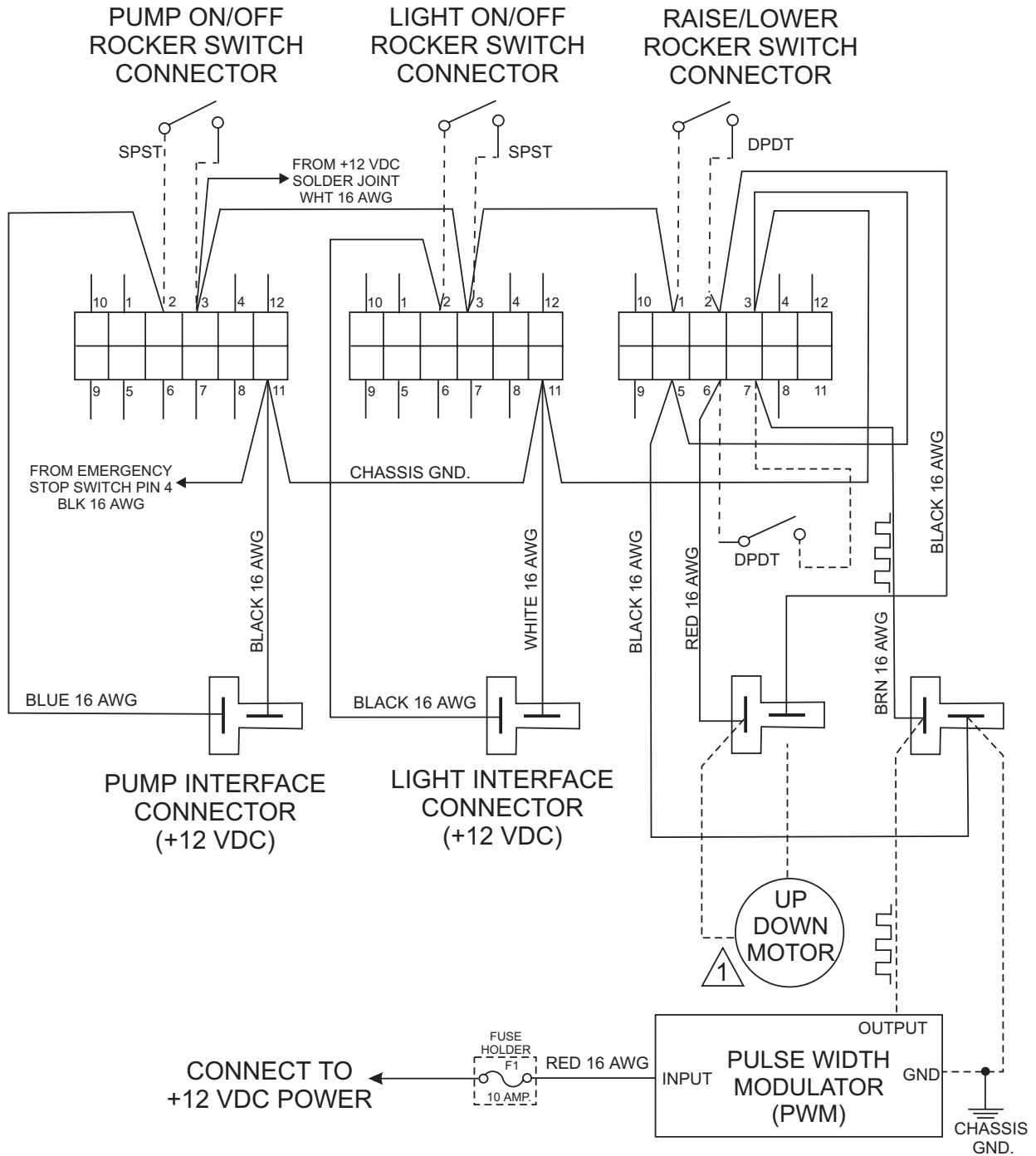

**NOTES:**

1

THE RAISE/LOWER (CUTTING BLADE) CAPABILITY IS AN OPTION. CONTACT MULTIQUIP SALES DEPT. REGARDING THIS FEATURE.

**PAYMENT TERMS**

Terms of payment for parts are net 10 days.

**FREIGHT POLICY**

All parts orders will be shipped collect or prepaid with the charges added to the invoice. All shipments are F.O.B. point of origin. Multiquip's responsibility ceases when a signed manifest has been obtained from the carrier, and any claim for shortage or damage must be settled between the consignee and the carrier.

**MINIMUM ORDER**

The minimum charge for orders from Multiquip is \$15.00 net. Customers will be asked for instructions regarding handling of orders not meeting this requirement.

**RETURNED GOODS POLICY**

Return shipments will be accepted and credit will be allowed, subject to the following provisions:

1. A Returned Material Authorization must be approved by Multiquip prior to shipment.
2. To obtain a Return Material Authorization, a list must be provided to Multiquip Parts Sales that defines item numbers, quantities, and descriptions of the items to be returned.
  - a. The parts numbers and descriptions must match the current parts price list.
  - b. The list must be typed or computer generated.
  - c. The list must state the reason(s) for the return.
  - d. The list must reference the sales order(s) or invoice(s) under which the items were originally purchased.
  - e. The list must include the name and phone number of the person requesting the RMA.
3. A copy of the Return Material Authorization must accompany the return shipment.

4. Freight is at the sender's expense. All parts must be returned freight prepaid to Multiquip's designated receiving point.
5. Parts must be in new and resalable condition, in the original Multiquip package (if any), and with Multiquip part numbers clearly marked.
6. The following items are not returnable:
  - a. Obsolete parts. (If an item is listed in the parts price book as being replaced by another item, it is obsolete.)
  - b. Any parts with a limited shelf life (such as gaskets, seals, "O" rings, and other rubber parts) that were purchased more than six months prior to the return date.
  - c. Any line item with an extended dealer net price of less than \$5.00.
  - d. Special order items.
  - e. Electrical components.
  - f. Paint, chemicals, and lubricants.
  - g. Decals and paper products.
  - h. Items purchased in kits.
7. The sender will be notified of any material received that is not acceptable.
8. Such material will be held for 5 working days from notification, pending instructions. If a reply is not received within 5 days, the material will be returned to the sender at his expense.
9. Credit on returned parts will be issued at dealer net price at time of the original purchase, less a 15% restocking charge.
10. In cases where an item is accepted for which the original purchase document can not be determined, the price will be based on the list price that was effective twelve months prior to the RMA date.
11. Credit issued will be applied to future purchases only.

**PRICING AND REBATES**

Prices are subject to change without prior notice. Price changes are effective on a specific date and all orders received on or after that date will be billed at the revised price. Rebates for price declines and added charges for price increases will not be made for stock on hand at the time of any price change.

Multiquip reserves the right to quote and sell direct to Government agencies, and to Original Equipment Manufacturer accounts who use our products as integral parts of their own products.

**SPECIAL EXPEDITING SERVICE**

A \$20.00 to \$50.00 surcharge will be added to the invoice for special handling including bus shipments, insured parcel post or in cases where Multiquip must personally deliver the parts to the carrier.

**LIMITATIONS OF SELLER'S LIABILITY**

Multiquip shall not be liable here under for damages in excess of the purchase price of the item with respect to which damages are claimed, and in no event shall Multiquip be liable for loss of profit or good will or for any other special, consequential or incidental damages.

**LIMITATION OF WARRANTIES**

No warranties, express or implied, are made in connection with the sale of parts or trade accessories nor as to any engine not manufactured by Multiquip. Such warranties made in connection with the sale of new, complete units are made exclusively by a statement of warranty packaged with such units, and Multiquip neither assumes nor authorizes any person to assume for it any other obligation or liability whatever in connection with the sale of its products. A part from such written statement of warranty, there are no warranties, express, implied or statutory, which extend beyond the description of the products on the face hereof.



# PARTS AND OPERATION MANUAL

## **HERE'S HOW TO GET HELP**

*PLEASE HAVE THE MODEL AND SERIAL NUMBER  
ON-HAND WHEN CALLING*

### **PARTS DEPARTMENT**

*800-427-1244 or 310-537-3700*

*FAX: 800-672-7877 or 310-637-3284*

### **SERVICE DEPARTMENT/TECHNICAL ASSISTANCE**

*800-478-1244 or 310-537-3700*

*FAX: 310- 537-4259*

### **WARRANTY DEPARTMENT**

*888-661-4279, or 310-661-4279*

*FAX: 310- 537-1173*

### **MAIN**

*800-421-1244 or 310-537-3700*

*FAX: 310-537-3927*



#### **MULTIQUIP INC.**

POST OFFICE BOX 6254

CARSON, CA 90749

310-537-3700 • 800-421-1244

FAX: 310-537-3927

E-MAIL: [mq@multiquip.com](mailto:mq@multiquip.com)

WWW: [multiquip.com](http://multiquip.com)

Atlanta • Boise • Dallas • Houston • Newark  
Quebec, Canada • Manchester, UK • Rio De Janeiro, BR • Guadalajara, MX

## Free Manuals Download Website

<http://myh66.com>

<http://usermanuals.us>

<http://www.somanuals.com>

<http://www.4manuals.cc>

<http://www.manual-lib.com>

<http://www.404manual.com>

<http://www.luxmanual.com>

<http://aubethermostatmanual.com>

Golf course search by state

<http://golfingnear.com>

Email search by domain

<http://emailbydomain.com>

Auto manuals search

<http://auto.somanuals.com>

TV manuals search

<http://tv.somanuals.com>