

OPERATION AND PARTS MANUAL



MODEL QP2TH TRASH PUMP (HONDA GX160K1QX2/GX160U1QX2/GX160UT2QX2 GASOLINE ENGINE)

Revision #5 (01/29/14)

To find the latest revision of this
publication, visit our website at:
www.multiquip.com



THIS MANUAL MUST ACCOMPANY THE EQUIPMENT AT ALL TIMES.



 WARNING 
CALIFORNIA — Proposition 65 Warning
Gasoline engine exhaust and some of its constituents are known to the State of California to cause cancer, birth defects and other reproductive harm.

TABLE OF CONTENTS

QP2TH Trash Pump

Proposition 65 Warning	2
Table Of Contents	4
Parts Ordering Procedures	5
Safety Information	6-10
Specifications (Pump).....	11
Specifications (Engine).....	12
General Information.....	13
Pump Components.....	14
Basic Engine.....	15
Inspection (Engine).....	16
Setup	17
Operation.....	18-19
Maintenance (Pump)	20-21
Maintenance (Engine)	22-24
Storage.....	25
Troubleshooting (Engine).....	26
Troubleshooting (Engine/Pump)	27
Explanation Of Code In Remarks Column.....	28
Suggested Spare Parts	29

Component Drawings

Pump Assembly.....	30-33
Engine Service Parts.....	34-35
Terms And Conditions Of Sale — Parts	36

NOTICE

Specifications and part numbers are subject to change without notice.

PARTS ORDERING PROCEDURES

Ordering parts has never been easier! Choose from three easy options:

Effective:
January 1st, 2006

www.multiquip.com



Order via Internet (Dealers Only):

Order parts on-line using Multiquip's SmartEquip website!

- View Parts Diagrams
- Order Parts
- Print Specification Information



If you have an MQ Account, to obtain a Username and Password, E-mail us at: parts@multiquip.com.

To obtain an MQ Account, contact your District Sales Manager for more information.

Goto www.multiquip.com and click on **Order Parts** to log in and save!

Use the **internet** and qualify for a **5% Discount** on *Standard orders* for all orders which include complete part numbers.*

Note: Discounts Are Subject To Change

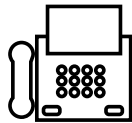

Order via Fax (Dealers Only):

All customers are welcome to order parts via Fax.

Domestic (US) Customers dial:
1-800-6-PARTS-7 (800-672-7877)

Fax your order in and qualify for a **2% Discount** on *Standard orders* for all orders which include complete part numbers.*

Note: Discounts Are Subject To Change



Order via Phone: Domestic (US) Dealers Call:
1-800-427-1244

Non-Dealer Customers:

Contact your local Multiquip Dealer for parts or call 800-427-1244 for help in locating a dealer near you.



International Customers should contact their local Multiquip Representatives for Parts Ordering information.

When ordering parts, please supply:

- | | |
|---|--|
| <input type="checkbox"/> Dealer Account Number | <input type="checkbox"/> Specify Preferred Method of Shipment: |
| <input type="checkbox"/> Dealer Name and Address | <input checked="" type="checkbox"/> UPS/Fed Ex <input checked="" type="checkbox"/> DHL |
| <input type="checkbox"/> Shipping Address (if different than billing address) | <input type="checkbox"/> Priority One <input checked="" type="checkbox"/> Truck |
| <input type="checkbox"/> Return Fax Number | <input type="checkbox"/> Ground |
| <input type="checkbox"/> Applicable Model Number | <input type="checkbox"/> Next Day |
| <input type="checkbox"/> Quantity, Part Number and Description of Each Part | <input type="checkbox"/> Second/Third Day |

NOTICE

All orders are treated as *Standard Orders* and will ship the same day if received prior to 3PM PST.

WE ACCEPT ALL MAJOR CREDIT CARDS!



SAFETY INFORMATION

Do not operate or service the equipment before reading the entire manual. Safety precautions should be followed at all times when operating this equipment. Failure to read and understand the safety messages and operating instructions could result in injury to yourself and others.



SAFETY MESSAGES

The four safety messages shown below will inform you about potential hazards that could injure you or others. The safety messages specifically address the level of exposure to the operator and are preceded by one of four words: **DANGER**, **WARNING**, **CAUTION** or **NOTICE**.

SAFETY SYMBOLS

! **DANGER**

Indicates a hazardous situation which, if not avoided, **WILL** result in **DEATH** or **SERIOUS INJURY**.

! **WARNING**

Indicates a hazardous situation which, if not avoided, **COULD** result in **DEATH** or **SERIOUS INJURY**.







! **CAUTION**

Indicates a hazardous situation which, if not avoided, **COULD** result in **MINOR** or **MODERATE INJURY**.

NOTICE

Addresses practices not related to personal injury.

Potential hazards associated with the operation of this equipment will be referenced with hazard symbols which may appear throughout this manual in conjunction with safety messages.

Symbol	Safety Hazard
	Lethal exhaust gas hazards
	Explosion hazards
	Burn hazards
	Pressurized fluid hazards
	Battery acid hazards
	Eye safety hazards

SAFETY INFORMATION

GENERAL SAFETY

CAUTION

- **NEVER** operate this equipment without proper protective clothing, shatterproof glasses, respiratory protection, hearing protection, steel-toed boots and other protective devices required by the job or city and state regulations.



- **NEVER** operate this equipment when not feeling well due to fatigue, illness or when under medication.



- **NEVER** operate this equipment under the influence of drugs or alcohol.



NOTICE

- This equipment should only be operated by trained and qualified personnel 18 years of age and older.
- Whenever necessary, replace nameplate, operation and safety decals when they become difficult read.
- Manufacturer does not assume responsibility for any accident due to equipment modifications. Unauthorized equipment modification will void all warranties.
- **NEVER** use accessories or attachments that are not recommended by Multiquip for this equipment. Damage to the equipment and/or injury to user may result.
- **ALWAYS** know the location of the nearest **fire extinguisher**.
- **ALWAYS** know the location of the nearest **first aid kit**.
- **ALWAYS** know the location of the nearest phone or **keep a phone on the job site**. Also, know the phone numbers of the nearest **ambulance, doctor** and **fire department**. This information will be invaluable in the case of an emergency.



PUMP SAFETY

DANGER

- **NEVER** pump volatile, explosive, flammable or low flash point fluids. These fluids could ignite or explode.
- The engine fuel exhaust gases contain poisonous carbon monoxide. This gas is colorless and odorless, and can cause death if inhaled.
- The engine of this equipment requires an adequate free flow of cooling air. **NEVER** operate this equipment in any enclosed or narrow area where free flow of the air is restricted. If the air flow is restricted it will cause injury to people and property and serious damage to the equipment or engine.



- **NEVER** operate the equipment in an explosive atmosphere or near combustible materials. An explosion or fire could result causing severe **bodily harm or even death**.



WARNING

- **NEVER** pump corrosive chemicals or water containing toxic substances. These fluids could create serious health and environmental hazards. Contact local authorities for assistance.
- **NEVER** open the priming plug when pump is hot. Hot water inside could be pressurized much like the radiator of an automobile. Allow pump to cool to the touch before loosening plug. The possibility exists of scalding, resulting in severe bodily harm.
- **NEVER** disconnect any **emergency or safety devices**. These devices are intended for operator safety. Disconnection of these devices can cause severe injury, bodily harm or even death. Disconnection of any of these devices will void all warranties.



SAFETY INFORMATION

CAUTION

- **NEVER** lubricate components or attempt service on a running machine.
- **NEVER** block or restrict flow from discharge hose. Remove kinks from discharge line before starting pump. Operation with a blocked discharge line can cause water inside pump to overheat.

NOTICE

- **ALWAYS** fill the pump casing with water before starting the engine. Failure to maintain water inside the pump housing will cause severe damage to the pump and mechanical seal.
- In winter drain water from pump housing to prevent freezing.
- **NEVER** start the pump with the clean-out cover removed. The rotating impeller inside the pump can cut or sever objects caught in it. Before starting the pump, check that the clean-out cover is securely fastened.
- **ALWAYS** keep the machine in proper running condition.
- **ALWAYS** ensure pump is on level ground before use.
- Fix damage to machine and replace any broken parts immediately.
- **ALWAYS** store equipment properly when it is not being used. Equipment should be stored in a clean, dry location out of the reach of children and unauthorized personnel.

ENGINE SAFETY

WARNING

- **NEVER** operate the engine with heat shields or guards removed.
- **DO NOT** remove the engine oil drain plug while the engine is hot. Hot oil will gush out of the oil tank and severely scald any persons in the general area of the pump.



CAUTION

- **NEVER** touch the hot exhaust manifold, muffler or cylinder. Allow these parts to cool before servicing equipment.



NOTICE

- **NEVER** run engine without an air filter or with a dirty air filter. Severe engine damage may occur. Service air filter frequently to prevent engine malfunction.
- **NEVER** tamper with the factory settings of the engine or engine governor. Damage to the engine or equipment can result if operating in speed ranges above the maximum allowable.



FUEL SAFETY

DANGER

- **DO NOT** add fuel to equipment if it is placed inside truck bed with plastic liner. Possibility exists of explosion or fire due to static electricity.

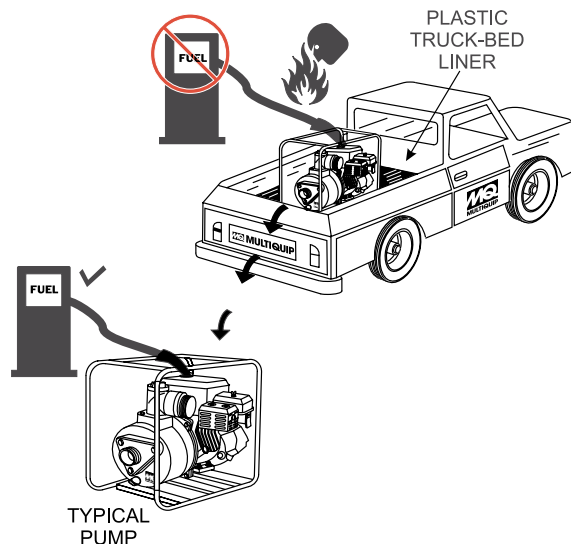

- **DO NOT** start the engine near spilled fuel or combustible fluids. Fuel is extremely flammable and its vapors can cause an explosion if ignited.
- **ALWAYS** refuel in a well-ventilated area, away from sparks and open flames.
- **ALWAYS** use extreme caution when working with flammable liquids.
- **DO NOT** fill the fuel tank while the engine is running or hot.
- **DO NOT** overfill tank, since spilled fuel could ignite if it comes into contact with hot engine parts or sparks from the ignition system.

SAFETY INFORMATION



- Store fuel in appropriate containers, in well-ventilated areas and away from sparks and flames.
- **NEVER** use fuel as a cleaning agent.
- **DO NOT** smoke around or near the equipment. Fire or explosion could result from fuel vapors or if fuel is spilled on a hot engine. 

BATTERY SAFETY (ELECTRIC START ONLY)

DANGER

- **DO NOT** drop the battery. There is a possibility that the battery will explode.
- **DO NOT** expose the battery to open flames, sparks, cigarettes, etc. The battery contains combustible gases and liquids. If these gases and liquids come into contact with a flame or spark, an explosion could occur. 

WARNING

- **ALWAYS** wear safety glasses when handling the battery to avoid eye irritation. The battery contains acids that can cause injury to the eyes and skin. 
- Use well-insulated gloves when picking up the battery.
- **ALWAYS** keep the battery charged. If the battery is not charged, combustible gas will build up.
- **DO NOT** charge battery if frozen. Battery can explode. When frozen, warm the battery to at least 61°F (16°C).
- **ALWAYS** recharge the battery in a well-ventilated environment to avoid the risk of a dangerous concentration of combustible gases.
- If the battery liquid (dilute sulfuric acid) comes into contact with **clothing or skin**, rinse skin or clothing immediately with plenty of water. 
- If the battery liquid (dilute sulfuric acid) comes into contact with **eyes**, rinse eyes immediately with plenty of water and contact the nearest doctor or hospital to seek medical attention.

CAUTION

- **ALWAYS** disconnect the **NEGATIVE** battery terminal before performing service on the equipment.
- **ALWAYS** keep battery cables in good working condition. Repair or replace all worn cables.

TRANSPORTING SAFETY

CAUTION

- **NEVER** allow any person or animal to stand underneath the equipment while lifting.

NOTICE

- Before lifting, make sure that the equipment parts (hook and vibration insulator) are not damaged and screws are not loose or missing.
- Always make sure crane or lifting device has been properly secured to the lifting bail (hook) of the equipment.
- **ALWAYS** shutdown engine before transporting.
- **NEVER** lift the equipment while the engine is running.
- Tighten fuel tank cap securely and close fuel cock to prevent fuel from spilling.
- Use adequate lifting cable (wire or rope) of sufficient strength.
- Use one point suspension hook and lift straight upwards.

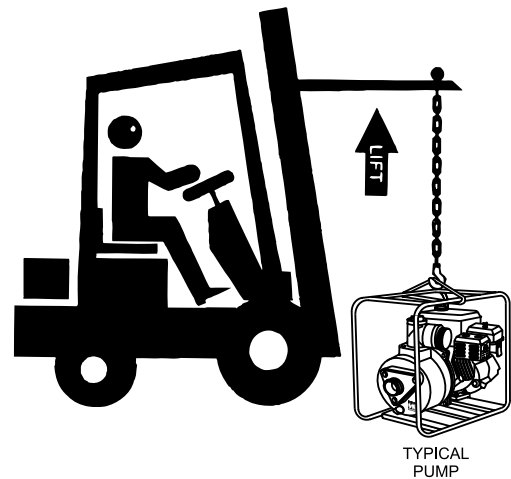

- **DO NOT** lift machine to unnecessary heights.
- **ALWAYS** tie down equipment during transport by securing the equipment with rope.

SAFETY INFORMATION

ENVIRONMENTAL SAFETY/DECOMMISSIONING

NOTICE

Decommissioning is a controlled process used to safely retire a piece of equipment that is no longer serviceable. If the equipment poses an unacceptable and unrepairable safety risk due to wear or damage or is no longer cost effective to maintain (beyond life-cycle reliability) and is to be decommissioned (demolition and dismantlement), be sure to follow rules below.

- **DO NOT** pour waste or oil directly onto the ground, down a drain or into any water source.
- Contact your country's Department of Public Works or recycling agency in your area and arrange for proper disposal of any electrical components, waste or oil associated with this equipment.
- When the life cycle of this equipment is over, remove battery and bring to appropriate facility for lead reclamation. Use safety precautions when handling batteries that contain sulfuric acid.
- When the life cycle of this equipment is over, it is recommended that the trowel frame and all other metal parts be sent to a recycling center.



Metal recycling involves the collection of metal from discarded products and its transformation into raw materials to use in manufacturing a new product.

Recyclers and manufacturers alike promote the process of recycling metal. Using a metal recycling center promotes energy cost savings.

EMISSIONS INFORMATION

NOTICE

The gasoline engine used in this equipment has been designed to reduce harmful levels of carbon monoxide (CO), hydrocarbons (HC) and nitrogen oxides (NOx) contained in gasoline exhaust emissions.

This engine has been certified to meet US EPA Evaporative emissions requirements in the installed configuration.

Attempting to modify or make adjustments to the engine emission system by unauthorized personnel without proper training could damage the equipment or create an unsafe condition.

Additionally, modifying the fuel system may adversely affect evaporative emissions, resulting in fines or other penalties.

Emission Control Label

The emission control label is an integral part of the emission system and is strictly controlled by regulation(s).

The label must remain with the engine for its entire life.

If a replacement emission label is needed, please contact your authorized engine distributor.

SPECIFICATIONS (PUMP)

Table 1. Specifications (Pump)		
Pump	Model	QP2TH
	Type	Trash Pump
	Suction	2.0 in. (51 mm.)
	Discharge Size	2.0 in. (51 mm.)
	Maximum Pumping Capacity	211 gallons/minute (800 liters/minute)
	Max. Solids Diameter	1.00 in. (25.4 mm)
	Max. Lift	25 ft. (7.6 m)
	Max. Head	98 ft. (30.0 m)
	Max. Pressure	42 psi (292 kPa)
Dry Net Weight	97 lbs. (44 Kg.)	

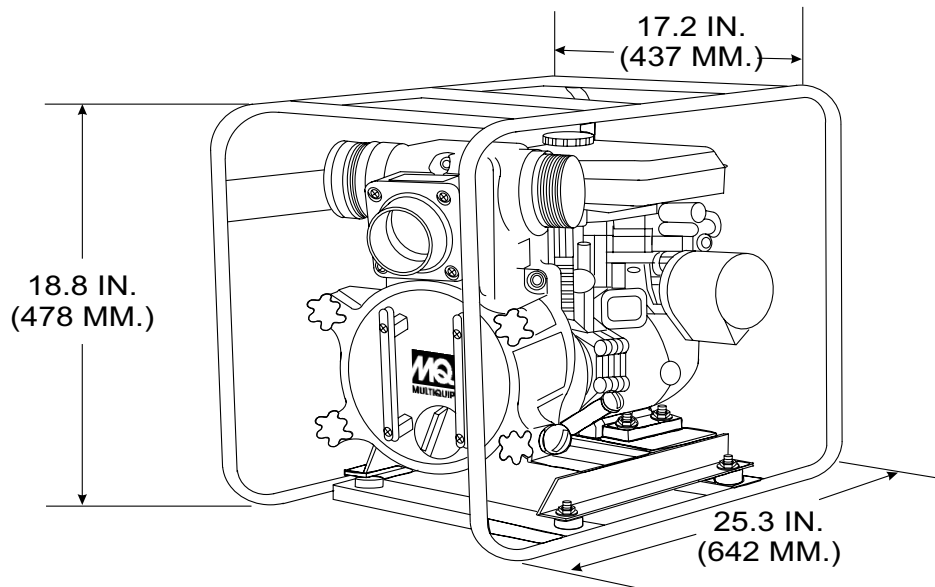

Figure 1. QP2TH Dimensions

SPECIFICATIONS (ENGINE)

Table 2. Specifications (Engines)		
Engine	Model	HONDA GX160K1QX2/ GX160U1QX2/GX160UT2QX2
	Type	Air-cooled 4 stroke, Single Cylinder, OHV, Horizontal Shaft Gasoline Engine
	Bore x Stroke	2.7 in. x 1.8 in. (68 mm x 45 mm)
	Displacement	163 cc (9.9 cu-in)
	Max Output	4.8 H.P./3,600 R.P.M.
	Fuel Tank Capacity	Approx.0.82 U.S. Gallons (3.1liters)
	Fuel	Unleaded Automobile Gasoline
	Lube Oil Capacity	0.61 quarts (0.58 liters)
	Speed Control Method	Centrifugal Fly-weight Type
	Starting Method	Recoil Start
	Dimension (L x W x H)	12.0 x 14.4 x 13.2 in. (304 x 362 x 335 mm)
Dry Net Weight	33.1 lbs (15 Kg.)	

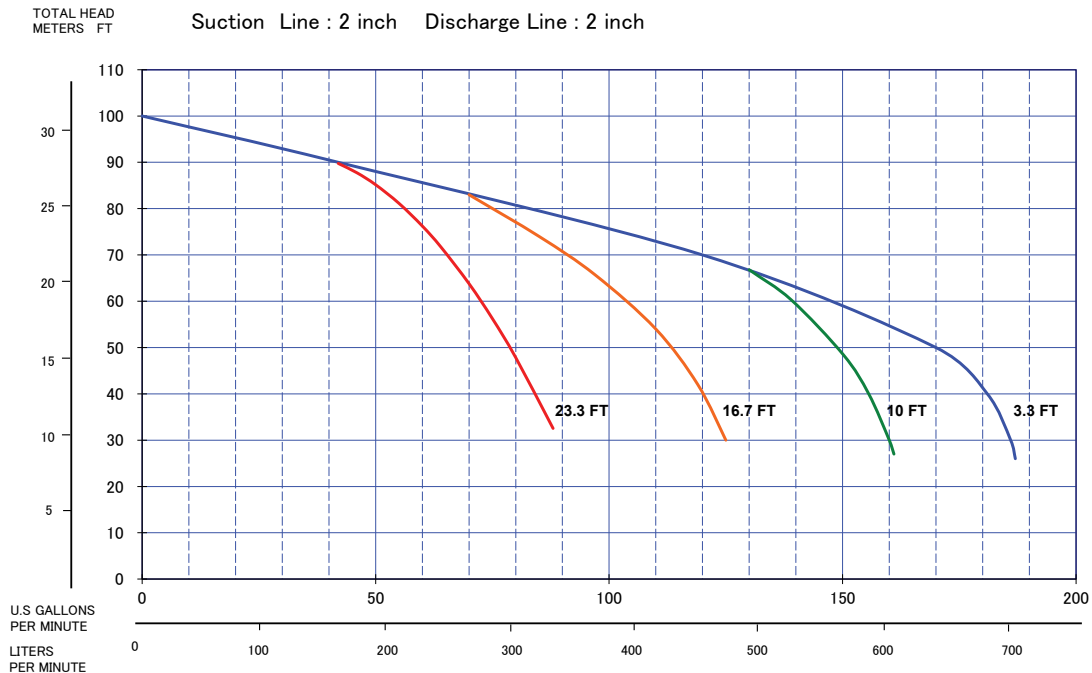

Figure 2. QP2TH Performance Curve

GENERAL INFORMATION

APPLICATION

The Multiquip QP2TH Trash Pump is designed to be used for dewatering applications. Both the suction and discharge ports on the QP2TH trash pump use a 2-inch diameter opening, which allows the pump to pump at a rate of approximately 211 gallons/minute (gpm) or 800 liters/minute (lpm).

Trash pumps are designed to purge air from the suction line and create a partial vacuum in the pump body. The reduced atmospheric pressure inside the pump allows water to flow through the suction line and into the pump body. The centrifugal force created by the rotating impeller pressurizes the water and expels it from the pump.

TRASH PUMP

Trash pumps derive their name from their ability to handle a greater amount of debris and solids than standard centrifugal pumps. These pumps generally handle solids up to 1/2 the size of the discharge opening making them less likely to clog. Also trash pumps are capable of handling water with 25% solids by weight.

The advantage of using a trash pump is that it can be quickly and easily disassembled in the field "without tools" and easily cleaned when clogged.

POWER PLANT

This trash pump is powered by a 4.8 horsepower air cooled 4-stroke, single cylinder HONDA GX160 gasoline engine that incorporates a low "Oil Alert Feature."

OIL ALERT FEATURE

In the event of low oil or no oil, the HONDA GX160 engine has a built-in oil alarm engine shut-down feature. In the event the oil level is low the engine will automatically shutdown.

SUCTION LIFT

This pump is intended to be used for dewatering applications and is capable of suction lifts up to 25 feet at sea level. For optimal suction lift performance keep the suction hose or line as short as possible. In general always place the pump as close to the water as possible.

PUMP SUPPORT

The pump should always be placed on solid stationary

ground in a level position.

NEVER place the pump on **soft soil**. The suction hose or pipe connection should always be checked for tightness and leaks. A small suction leak in the hose or fittings could prevent the pump from priming.

Elevation

Higher elevations will effect the performance of the pump. Due to less atmospheric pressure at higher altitudes, pumps **DO NOT** have the priming ability that they have at sea level. This is due to the "thinner air" or lack of oxygen at higher altitudes.

A general rule of thumb is that for every 1,000 feet of elevation above sea level a pump will lose one foot of priming ability.

For example, in Flagstaff, Arizona where the elevation is approximately 7,000 feet, the pump would have a suction lift of only 18 feet rather than the 25 feet at sea level. Table 3 shows suction lift at various elevations.

Table 3. Suction Lift at Various Elevations

Altitude Feet (Meters)	Suction Lift in Feet (Meters)			
Sea Level	10.0 (3.048)	15.0 (4.572)	20.0 (6.096)	25.0 (7.620)
2,000 (610)	8.80 (2.680)	13.2 (4.023)	17.6 (5.364)	22.0 (6.705)
4,000 (1,219)	7.80 (2.377)	11.7 (3.566)	15.6 (4.754)	19.5 (5.943)
6,000 (1,829)	6.90 (2.103)	10.4 (3.169)	13.8 (4.206)	17.3 (5.273)
8,000 (2,438)	6.20 (1.889)	9.30 (2.834)	12.4 (3.779)	15.5 (4.724)
10,000 (3,048)	5.70 (1.737)	8.60 (2.621)	11.4 (3.474)	14.3 (4.358)

Table 4 shows percentage drops in performance as elevation increases.

Table 4. Performance Loss at Various Elevations

Altitude Feet (Meters)	Discharge Flow	Discharge Head
Sea Level	100%	100%
2,000 (610)	97%	95%
4,000 (1,219)	95%	91%
6,000 (1,829)	93%	87%
8,000 (2,438)	91%	83%
10,000 (3,048)	88%	78%

PUMP COMPONENTS

Figure 3 shows a typical application using the QP2TH centrifugal pump. Please note that this pump is intended for the removal of clean water.

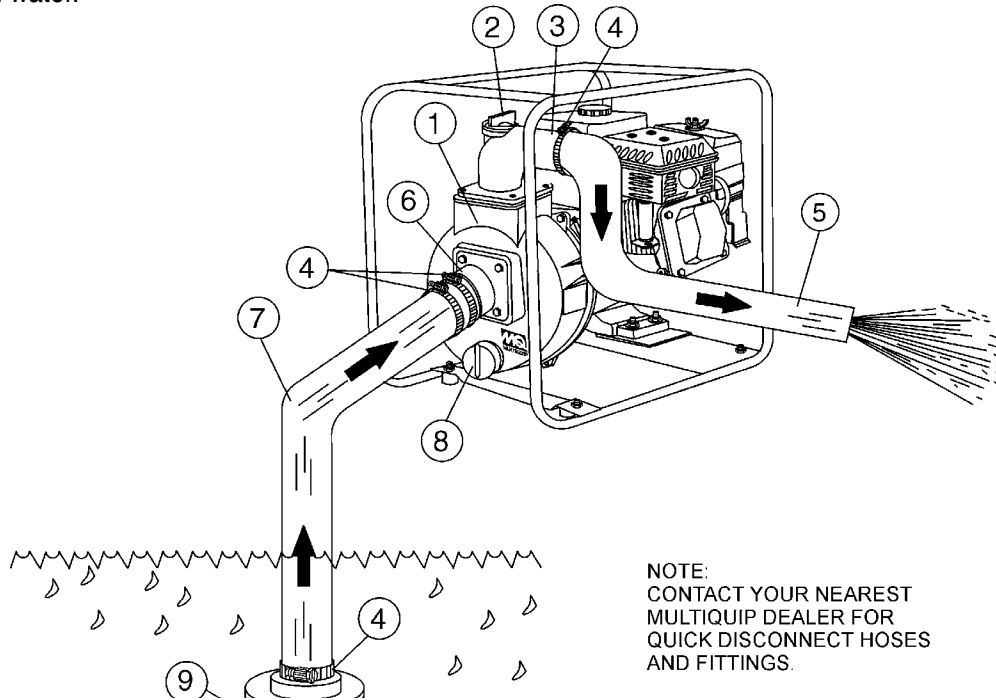

Figure 3. QP2TH Pump Application

- 1. Pump** — The model QP2TH is a 2-inch trash pump used in general dewatering applications. Typical dewatering applications consist of manholes, septic tanks, fast and slow seepage ditch water, silt water, mud water and muck water.
- 2. Fill Cap** — Prior to operation, the pump casing should be filled with water. Remove this cap to add water to the pump. After the initial prime, a sufficient amount of water will be retained in the casing so that the operator will not need to re-prime later.
- 3. Discharge Port** — Connect a 2-inch discharge hose to this port. Note there are 2 ports.
- 4. Worm Clamp** — Used to secure the hose to the inlet and outlet ports on the pump. Use two clamps to secure the hose on the inlet side of the pump.
- 5. Discharge Hose** — Connect a flexible rubber hose to the discharge port on the pump. Make sure that the hose lays flat and is not kinked. Use only recommended type discharge hose. Contact Multiquip Parts Department for ordering information.
- 6. Suction Port** — Connect a 2-inch inlet hose to this port. Use two worm clamps to secure the hose.
- 7. Suction Hose** — Connect this flexible rubber hose to the suction port on the pump. Make sure that the hose lays flat and is not kinked. Use only recommended type suction hose. Contact Multiquip parts department for ordering information.
- 8. Clean-out Cover Handles** — To gain access to the pump's clean-out area, grip both handles, then pull to remove cover. Make sure both locking knobs have been released before attempting to remove clean-out cover.
- 9. Drain Plug** — Remove this plug to drain water from the pump.
- 10. Clean-out Cover** — Remove cover to gain access to the clean-out area.
- 11. Locking Knobs** — Turn both knobs clockwise to secure clean-out cover, turn counter-clockwise to release cover.
- 12. Strainer** — Always attach a strainer to bottom side of the suction hose to prevent large objects and debris from entering the pump. Strainer should be positioned so that it will remain completely under water. Running the pump with the strainer above water for long periods can damage pump.

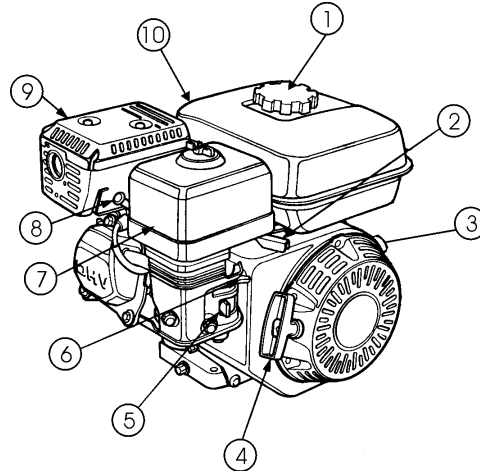

Figure 4. Engine Controls and Components

INITIAL SERVICING

The engine (See Figure 4) must be checked for proper lubrication and filled with fuel prior to operation. Refer to the manufacturer's engine manual for instructions and details of operation and servicing. The engine shown above is a HONDA engine, operation for other types of engines may vary somewhat.

1. **Fuel Filler Cap** — Remove this cap to add unleaded gasoline to the fuel tank. Make sure cap is tightened securely. **DO NOT** over fill.

DANGER



Adding fuel to the tank should be done only when the engine is stopped and has had an opportunity to cool down. In the event of a fuel spill, **DO NOT** attempt to start the engine until the fuel residue has been completely wiped up, and the area surrounding the engine is dry.

2. **Throttle Lever** — Used to adjust engine RPM speed (lever advanced forward **SLOW**, lever back toward operator **FAST**).
3. **Engine ON/OFF Switch** — ON position permits engine starting, OFF position stops engine operations.
4. **Recoil Starter (pull rope)** — Manual-starting method. Pull the starter grip until resistance is felt, then pull briskly and smoothly.
5. **Fuel Valve Lever** — **OPEN** to let fuel flow, **CLOSE** to stop the flow of fuel.

6. **Choke Lever** — Used in the starting of a cold engine, or in cold weather conditions. The choke enriches the fuel mixture.
7. **Air Cleaner** — Prevents dirt and other debris from entering the fuel system. Remove wing-nut on top of air filter canister to gain access to filter element.

NOTICE

Operating the engine without an air filter, with a damaged air filter, or a filter in need of replacement will allow dirt to enter the engine, causing rapid engine wear.

WARNING



Engine components can generate extreme heat. To prevent burns, **DO NOT** touch these areas while the engine is running or immediately after operating. **NEVER** operate the engine with the muffler removed.

8. **Spark Plug** — Provides spark to the ignition system. Set spark plug gap to 0.6 - 0.7 mm (0.028 - 0.031 inch). Clean spark plug once a week.
9. **Muffler** — Used to reduce noise and emissions.
10. **Fuel Tank** — Holds unleaded gasoline. For additional information refer to engine owner's manual.

INSPECTION (ENGINE)

CAUTION



DO NOT attempt to operate the pump until the Safety Information, General Information and Inspection sections of this manual have been read and thoroughly understood.

BEFORE STARTING

1. Read safety instructions at the beginning of manual.
2. Clean the pump, removing dirt and dust, particularly the engine cooling air inlet, carburetor and air cleaner.
3. Check the air filter for dirt and dust. If air filter is dirty, replace air filter with a new one as required.
4. Check carburetor for external dirt and dust. Clean with dry compressed air.
5. Check fastening nuts and bolts for tightness.

Engine Oil Check

1. To check the engine oil level, place the pump on secure level ground with the engine stopped.
2. Remove the filler dipstick from the engine oil filler hole (See Figure 5) and wipe clean.

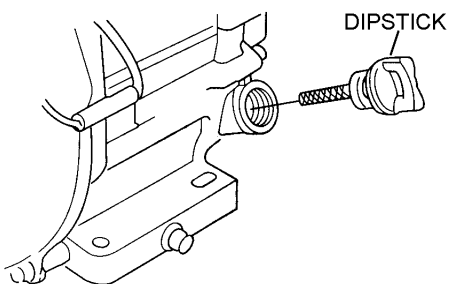

Figure 5. Engine Oil Dipstick (Removal)

3. Insert and remove the dipstick without screwing it into the filler neck. Check the oil level shown on the dipstick.
4. If the oil level is low (See Figure 6), fill to the edge of the oil filler hole with the recommended oil type (Table 5). Maximum oil capacity is 0.61 quarts (0.58 liters).

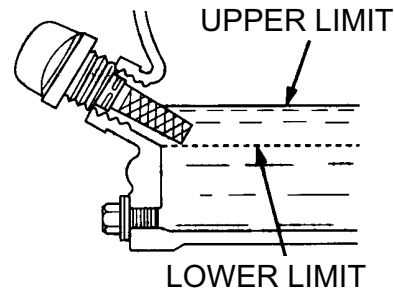

Figure 6. Engine Oil Dipstick (Oil Level)

Table 5. Oil Type

Season	Temperature	Oil Type
Summer	25°C or Higher	SAE 10W-30
Spring/Fall	25°C~10°C	SAE 10W-30/20
Winter	0°C or Lower	SAE 10W-10

DANGER



Motor fuels are highly flammable and can be dangerous if mishandled. **DO NOT** smoke while refueling. **DO NOT** attempt to refuel the pump if the engine is **hot!** or running.

Fuel Check

1. Remove the gasoline cap located on top of fuel tank.
2. Visually inspect to see if the fuel level is low. If fuel is low, replenish with unleaded fuel.
3. When refueling, be sure to use a strainer for filtration. **DO NOT** top-off fuel. Wipe up any spilled fuel **immediately!**

1. Place pump as near to water as possible, on a firm flat, level surface.
2. To prime pump, remove fill cap (See Figure 3) and fill pump casing with water. If the pump casing is not filled with water before starting, it will not begin pumping.
3. Attach suction and discharge hoses to the pump. Check that all hoses are **securely** attached to the pump. Make certain suction hose (See Figure 3) does not have any air leakage. Tighten hose clamps and couplings as required.
4. It is recommended that 2 clamps be used when securing the suction hose to the inlet side (suction) of the pump.
5. Remember suction hoses must be **rigid** enough not to collapse when the pump is in operation.
6. Check that the **discharge** hose (See Figure 3) is not restricted. Place hose so that it lays as straight as it is possible on the ground. Remove any twists or sharp bends from hose which may block the flow of water.

NOTICE

Suction and discharge hoses are available from Multiquip. Contact your nearest dealer for more information.

7. The discharge hose is usually a **collapsible** (thin-walled) hose, however if a thin-walled discharge hose is not available, a rigid suction hose can be substituted in its place.
8. Make sure the **suction strainer** (See Figure 3) is clean and securely attached to the water end of the suction hose. The strainer is designed to protect the pump by preventing large objects from being pulled in to the pump.

CAUTION

The strainer should be positioned so it will remain completely **under water**. Running the pump with the strainer above water for long periods can damage the pump.

CAUTION

DO NOT attempt to start the engine unless the pump has previously been primed with water. Severe pump damage will occur if pump has not been primed.

STARTING THE ENGINE

1. Place the engine fuel valve lever (See Figure 7) to the **ON** position.

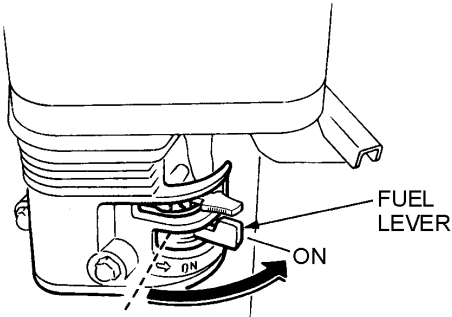

Figure 7. Engine Fuel Valve Lever (ON Position)

2. Move the throttle lever (See Figure 8) away from the slow position, about 1/3 of the way toward the fast position.

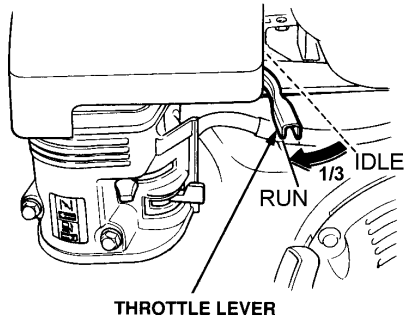

Figure 8. Throttle Lever (1/3 Start Position)

3. Place the choke lever (See Figure 9) in the **CLOSED** position if starting a cold engine.

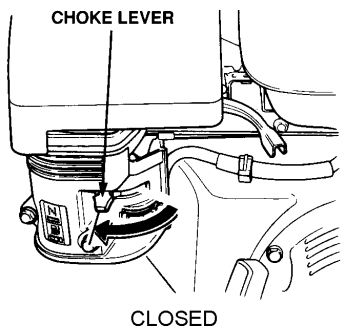

Figure 9. Engine Choke Lever (Closed)

4. Place the choke lever (See Figure 10) in the **OPEN** position if starting a warm engine or the temperature is warm.

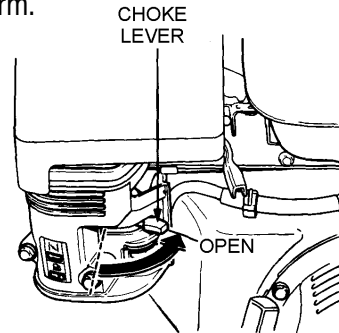

Figure 10. Engine Choke Lever (Open)

5. Place the engine **ON/OFF** switch (See Figure 11) in the **ON** position.

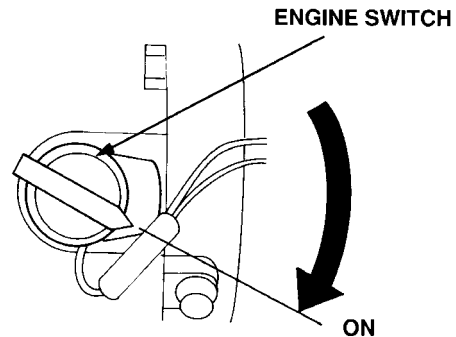

Figure 11. Engine ON/OFF Switch (ON Position)

6. Grasp the starter grip (See Figure 12) and slowly pull it out. The resistance becomes the hardest at a certain position, corresponding to the compression point. Pull the starter grip briskly and smoothly for starting.

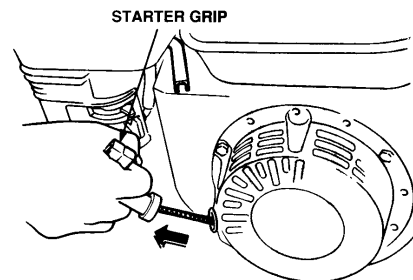

Figure 12. Starter Grip

7. If the engine has started and the choke lever was moved to the **CLOSED** position to start the engine, gradually move the choke lever to the **OPEN** position (Figure 13) as the engine warms up. If the engine has not started repeat steps 1 through 6.

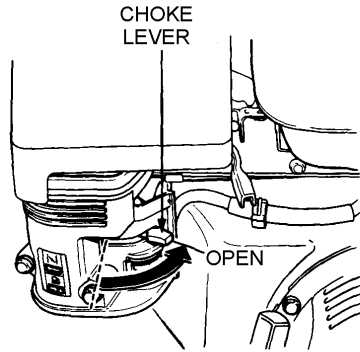

Figure 13. Choke Lever (Open)

8. Before the pump is placed in to operation, run the engine for several minutes. Check for fuel leaks, and noises that would associate with a lose component.
9. To begin pumping, place the throttle lever (See Figure 14) in the **RUN** position. If water is not flowing out of the discharge port, turn off the engine and check for and clear any obstructions within the suction hose.

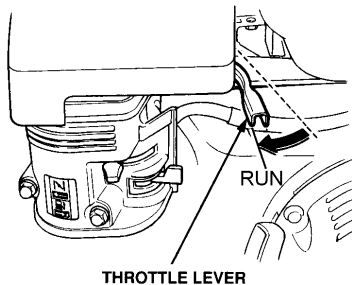

Figure 14. Throttle Lever (Run)

WARNING

Water must always be flowing through the pump casing while the engine is running. Loss of flow may be the result of a loss of prime, restricted water flow or a dead-head situation. Please note that in such a condition, water in the pump can reach temperatures of 150-200°F in 15 to 20 minutes. This can cause serious burns if this hot water comes into contact with unprotected skin.

Before touching or opening the fill plug or drain plug, first turn off the engine and allow the pump casing to cool to the touch, and then open the pump carefully. Be cautious of any built up water pressure.

CAUTION

ALWAYS run engine at **full speed** while pumping.

STOPPING THE ENGINE

Normal Shutdown

1. Move the throttle lever to the **IDLE** position (See Figure 15) and run the engine for three minutes at low speed.

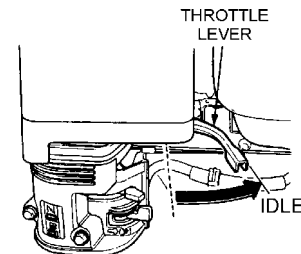

Figure 15. Throttle Lever (Idle)

2. After the engine cools, turn the engine **ON/OFF** switch to the **OFF** position (See Figure 16).

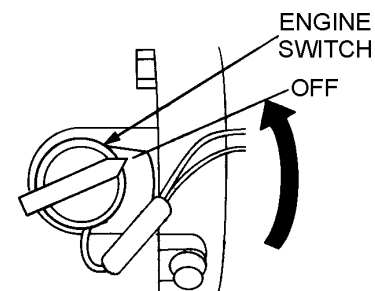

Figure 16. Engine ON/OFF Switch (OFF)

3. Place the fuel shut-off lever (See Figure 17) in the **OFF** position

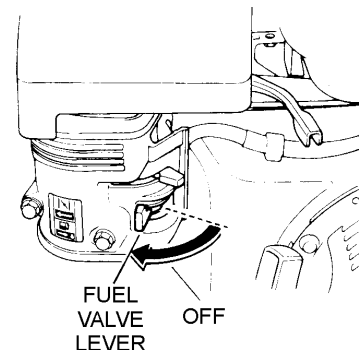

Figure 17. Fuel Valve Lever (OFF)

Emergency Shutdown

1. Move the throttle lever quickly to the **IDLE** position, and place the engine **ON/OFF** switch in the **OFF** position.

MAINTENANCE (PUMP)

PUMP VACUUM TEST

CAUTION

DO NOT attempt to start the engine unless the pump has previously been **primed** with water. Severe pump damage will occur if pump has not been primed.

To perform the pump vacuum test do the following:

1. Remove the pump fill cap (See Figure 3), and fill the pump with water.
2. Start the engine as outlined in the initial start-up section, and wait for the pump to begin pumping.
3. As shown in Figure 18, place a water hose inside the discharge opening of the pump, and turn on the water. This flow of water into the discharge opening will **prevent** the pump from running dry.
4. Place the Pump Vacuum Tester (P/N 7000030) over the pump suction (inlet) opening (See Figure 18) with the vacuum gauge facing upwards. It may be necessary to apply a small amount of water around the rubber seal of the vacuum tester to make a good suction fit.
5. Check and make sure that there are no air leaks between the vacuum tester and the inlet port on the pump. If air leaks are present reseal vacuum tester.
6. Run the pump for a few minutes while monitoring the vacuum gauge. If the gauge indicates a reading between -25 and -20 in. Hg. (inches of mercury) then it can be assumed that the pump is working correctly.

NOTICE

25 in. Hg (inches of mercury) translates into 25 feet of lift at **sea level**.

7. If the vacuum tester gauge indicates a reading below -20 in. Hg, it can then be assumed that the pump is not functioning correctly, and corrective action needs to be taken.
8. To test the flapper valve, shutdown the engine. The vacuum tester should remain attached to the pump suction inlet port by vacuum. This indicates the pump's flapper valve is seating properly to hold water in the suction hose when the engine is stopped. This prevents backflow and allows for faster priming when the engine is restarted.

ADJUSTING IMPELLER CLEARANCE

1. If it is necessary to replace impeller or volute, be sure clearance between impeller and volute is adjusted
2. The impeller should be as close to the volute as possible without rubbing against it. Clearance is adjusted by adding or removing shims from behind the impeller.
3. Check clearance between impeller and insert by slowly pulling starter rope to turn impeller.

NOTICE

It is important not to remove too many shims or the clearance between the impeller and volute will become **too wide** and pump performance will be reduced. Remember as the impeller wear down, additional shims may be required to maintain the clearance between the impeller and insert.

4. Check the impeller every six months for wear, and for clearance between the impeller face and the volute. Also check the shaft seal for wear, as well as the shaft sleeve.

PUMP CLEANING

After pumping water containing large amounts of dirt and debris, perform the following:

1. Remove the drain plug from the pump housing (Figure 3) and drain any water left in the pump.
2. Loosen the two locking hand knobs (turn counterclockwise) and remove clean-out cover.
3. Clean and remove dirt, debris from pump casing. Inspect impeller and volute for wear. Replace any damaged or worn parts.

CAUTION

The impeller may develop sharp edges. Use extreme care when cleaning around the impeller to prevent being cut..

MAINTENANCE (PUMP)

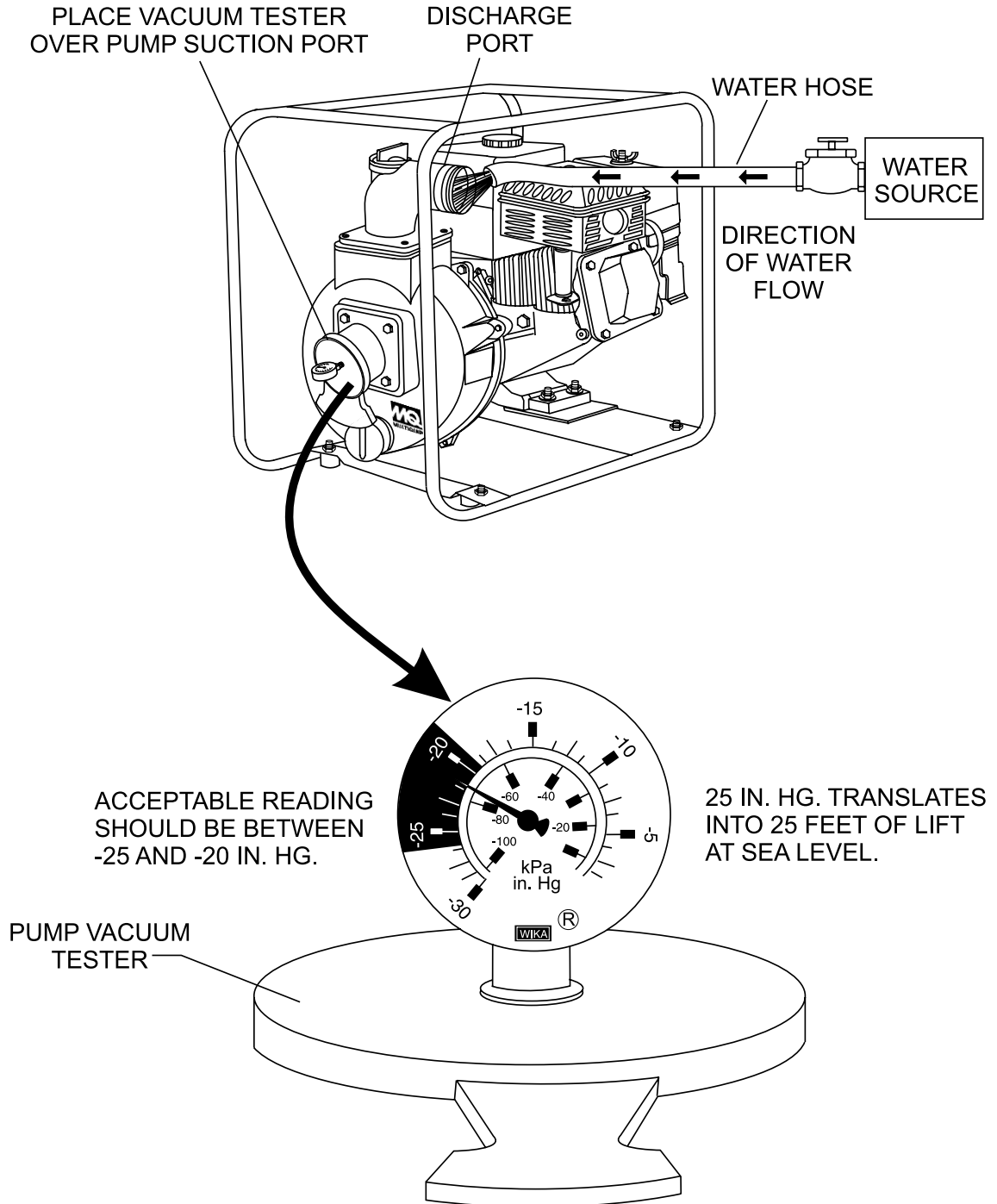

Figure 18. Pump Vacuum Tester

MAINTENANCE (ENGINE)

ENGINE MAINTENANCE

Perform engine maintenance procedures as referenced by Table 6 below:

Table 6. Engine Maintenance Schedule							
Description (3)	Operation	Before	First Month or 10 hrs	Every 3 Months or 25 hrs	Every 6 Months or 50 hrs	Every Year or 100 hrs	Every 2 Years or 200 hrs
Engine Oil	CHECK	X					
	CHANGE		X				
Air Cleaner	CHECK	X					
	CHANGE			X (1)			
All Nuts and Bolts	Re-tighten If Necessary	X					
Spark Plug	CHECK-CLEAN				X		
	REPLACE						X
Cooling Fins	CHECK				X		
Spark Arrester	CLEAN					X	
Fuel Tank	CLEAN					X	
Fuel Filter	CHECK					X	
Idle Speed	CHECK-ADJUST					X (2)	
Valve Clearance	CHECK-ADJUST						X (2)
Fuel lines	CHECK	Every 2 years (replace if necessary) (2)					

1. Service more frequently when used in **DUSTY** areas.
2. These items should be serviced by your service dealer, unless you have the proper tools and are mechanically proficient. Refer to the HONDA shop Manual for service procedures.
3. For commercial use, log hours of operation to determine proper maintenance intervals.

NOTICE

Refer to manufacturer engine manual for specific servicing instructions.

MAINTENANCE (ENGINE)

DAILY

1. Thoroughly remove dirt and oil from the engine and control area. Clean or replace the air cleaner elements as necessary. Check and retighten all fasteners as necessary. Check the spring box and bellows for oil leaks. Repair or replace as needed.

WEEKLY

1. Remove the fuel filter cap and clean the inside of the fuel tank.
2. Remove or clean the filter at the bottom of the tank.
3. Remove and clean the spark plug (See Figure 19), then adjust the spark gap to 0.028~0.031 inch (0.6~0.7 mm). This unit has electronic ignition, which requires no adjustments.

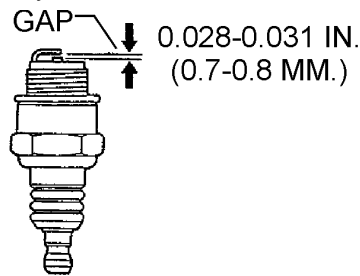

Figure 19. Spark Plug Gap

ENGINE OIL

1. Drain the engine oil when the oil is **warm** as shown in Figure 20.
2. Remove the oil drain bolt and sealing washer and allow the oil to drain into a suitable container.
3. Replace engine oil with recommended type oil as listed in Table 5. Engine oil capacity is 1.16 quarts (1.1 liters). **DO NOT** over fill.
4. Install drain bolt with sealing washer and tighten securely.

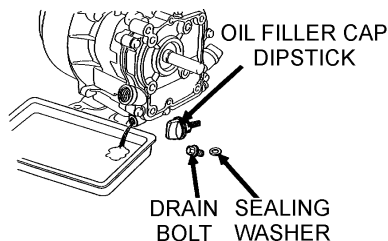

Figure 20. Engine Oil (Draining)

DANGER



DO NOT use gasoline as a cleaning solvent, because that would create a risk of fire or explosion.

ENGINE AIR CLEANER

1. Remove the air cleaner cover and foam filter element as shown in Figure 21.
2. Tap the paper filter element (See Figure 21) several times on a hard surface to remove dirt, or blow compressed air [not exceeding 30 psi (207 kPa, 2.1 kgf/cm²)] through the filter element from the air cleaner case side. **NEVER** brush off dirt. Brushing will force dirt into the fibers. Replace the paper filter element if it is excessively dirty.
3. Clean foam element in warm, soapy water or non-flammable solvent. Rinse and dry thoroughly. Dip the element in clean engine oil and completely squeeze out the excess oil from the element before installing.

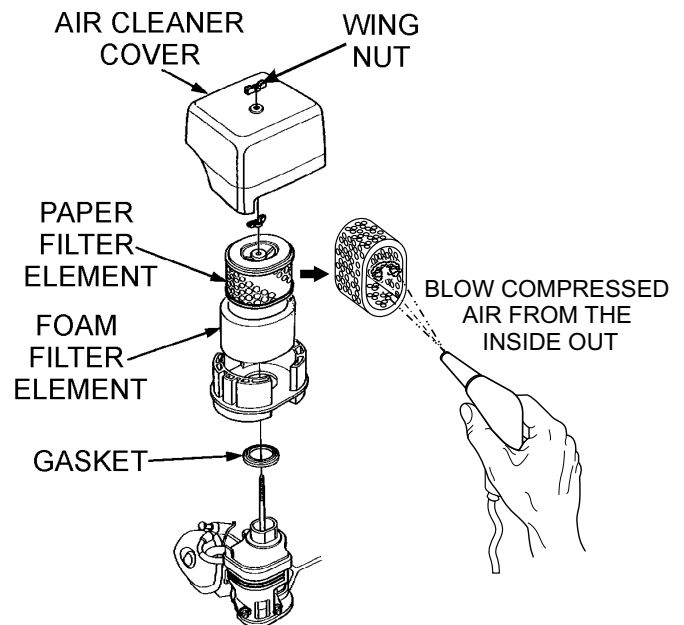

Figure 21. Engine Air Cleaner

MAINTENANCE (ENGINE)

SPARK ARRESTER CLEANING

Clean the spark arrester every 6 months or 100 hours.

1. Remove the 4 mm screw (3) from the exhaust deflector, then remove the deflector. See Figure 22.
2. Remove the 5 mm screw (4) from the muffler protector, then remove the muffler protector.
3. Remove the 4 mm screw from the spark arrester, then remove the spark arrester.

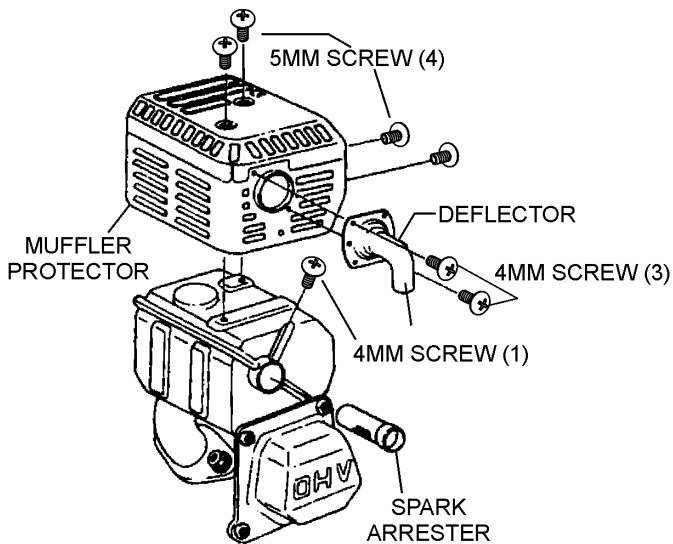

Figure 22. Spark Arrester Removal

4. Carefully remove carbon deposits from the spark arrester screen (Figure 23) with a wire brush.

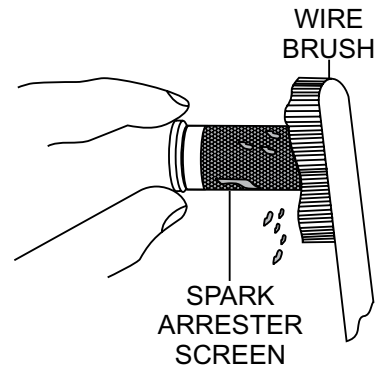

Figure 23. Cleaning The Spark Arrester

5. If the spark arrester is damaged and has breaks or holes, replace with a new one.
6. Reinstall the spark arrester and muffler protector in reverse order of disassembly.

PUMP STORAGE

For storage of the pump for over 30 days, the following is required:

- Drain the fuel tank completely.
- Run the engine until the fuel is completely consumed.
- Completely drain used oil from the engine crankcase and fill with fresh clean oil, then follow the procedures described in the engine manual for engine storage.
- Remove the drain plug from the pump and drain out any water from left in the housing.
- Remove the pump cover and clean inside of pump housing. Coat inside of pump housing with a light film of oil to reduce corrosion. A spray can of oil works well for this application.
- Cover suction and discharge ports with duct tape to prevent any foreign matter from falling into pump.
- Cover pump and engine with plastic covering or equivalent and store in a clean, dry place.
- To protect the water cooled-seals, place one-half pint of lubricating oil (new or used) through the discharge opening on the pump and crank the engine several times. This will prevent excessive corrosion and also keep the mechanical seal lubricated.

TROUBLESHOOTING (ENGINE)

Table 7. Engine Troubleshooting

Symptom	Possible Problem	Solution
Difficult to start		
Fuel is available but spark plug will not ignite. (Power available at high tension cable).	Ignition plug being bridge?	Check ignition system.
	Carbon deposit at ignition?	Clean or replace ignition.
	Short circuit due to defective insulators?	Replace insulators.
	Improper spark gap?	Set spark plug gap to the correct gap.
Fuel is available but spark plug will not ignite. (Power NOT available at high tension cable).	Short circuit at stop switch?	Check stop switch circuit. Replace stop switch if defective.
	Ignition coil defective?	Replace ignition coil.
Fuel is available and spark plug ignites (compression normal).	Muffler clogged with carbon deposits?	Clean or replace muffler.
	Mixed fuel quality is inadequate?	Check fuel to oil mixture.
	Fuel in use inadequate (water, dust)?	Flush fuel system and replace with fresh fuel.
	Air Cleaner clogged?	Clean or replace air cleaner.
Fuel is available and spark plug ignites (compression low).	Defective cylinder head gasket?	Tighten cylinder head bolts or replace head gasket.
	Cylinder worn?	Replace cylinder.
	Spark plug loose?	Tighten spark plug.
Operation not satisfactory		
Not enough power available (compression normal, no miss-firing).	Air cleaner clogged?	Clean or replace air cleaner.
	Air in fuel line?	Bleed (remove air) from fuel line.
	Fuel level in carburetor float chamber improper?	Adjust carburetor float.
	Carbon deposits in cylinder?	Clean or replace cylinder.
Not enough power available (compression normal, miss-firing).	Ignition coil defective?	Flush fuel system and replace with fresh fuel.
	Ignition plug often shorts?	Replace ignition wires, clean ignition.
	Fuel in use inadequate (water, dust)?	Flush fuel system and replace with fresh fuel.
Engine overheats.	Excessive carbon deposition in combustion chamber?	Clean or replace crankcase.
	Exhaust or muffler clogged with carbon.	Clean or replace muffler.
	Spark plug heat value incorrect?	Replace spark plug with correct type spark plug.

TROUBLESHOOTING (ENGINE/PUMP)

Table 7. Engine Troubleshooting

Symptom	Possible Problem	Solution
Operation not satisfactory		
Rotational speed fluctuates.	Governor adjustment improper?	Adjust governor to correct lever.
	Governor spring defective?	Clean or replace ignition.
	Fuel flow erratic?	Check fuel line.
	Air taken in through suction line?	Check suction line.
Recoil starter not working properly.	Dust in rotating part?	Clean recoil starter assembly.
	Spring failure?	Replace spiral spring.

Table 8. Pump Troubleshooting

Symptom	Possible Problem	Solution
Pump does not take on water.	Not enough priming water in the housing?	Add water.
	Engine speed too low?	Increase throttle.
	Strainer plugged?	Clean strainer.
	Suction hose damaged?	Replace or repair hose, and clamps.
	Air leak at suction port?	Check that fittings are tight and properly sealed.
	Pump is located too high above water line?	Move pump closer to water.
	Debris collecting in pump housing?	Clean pump housing.
	Too much distance between impeller and volute.	Adjust clearance by adding shims or replace impeller. Min. .006" - Max. .020".
	Water leaking out weep hole between pump and engine?	Check condition of mechanical seal and gaskets, between pump end and engine housing.
Pump takes in water, little or no discharge.	Engine speed too low?	Increase throttle speed.
	Suction strainer partially plugged?	Clean strainer.
	Impeller/Volute worn?	Adjust clearance by adding shims or replace impeller/volute.
Suction hose leaks at inlet.	Fittings/clamps are not sealed properly?	Tighten, replace or add clamp. (Keep extra seals on pump).
	Hose diameter is too large?	Use smaller diameter hose or replace hose.
Discharge does not stay on coupling.	Pressure too high?	Check pressure, add additional clamp.
	Hose kinked or end blocked?	Check hose.
Impeller does not turn: pump is hard to start.	Impeller jammed or blocked?	Open pump cover and clean dirt and debris from inside housing.
	Impeller and volute binding?	Adjust clearance by removing shim from behind impeller.
	Defective engine?	See Engine Owner's Manual.

EXPLANATION OF CODE IN REMARKS COLUMN

The following section explains the different symbols and remarks used in the Parts section of this manual. Use the help numbers found on the back page of the manual if there are any questions.

NOTICE

The contents and part numbers listed in the parts section are subject to change **without notice**. Multiquip does not guarantee the availability of the parts listed.

SAMPLE PARTS LIST

NO.	PART NO.	PART NAME	QTY.	REMARKS
1	12345	BOLT	1	INCLUDES ITEMS W/%
2%		WASHER, 1/4 IN.		NOT SOLD SEPARATELY
2%	12347	WASHER, 3/8 IN. ...	1	MQ-45T ONLY
3	12348	HOSE	A/R	MAKE LOCALLY
4	12349	BEARING	1	S/N 2345B AND ABOVE

NO. Column

Unique Symbols — All items with same unique symbol (@, #, +, %, or >) in the number column belong to the same assembly or kit, which is indicated by a note in the “Remarks” column.

Duplicate Item Numbers — Duplicate numbers indicate multiple part numbers, which are in effect for the same general item, such as different size saw blade guards in use or a part that has been updated on newer versions of the same machine.

NOTICE

When ordering a part that has more than one item number listed, check the remarks column for help in determining the proper part to order.

PART NO. Column

Numbers Used — Part numbers can be indicated by a number, a blank entry, or TBD.

TBD (To Be Determined) is generally used to show a part that has not been assigned a formal part number at the time of publication.

A blank entry generally indicates that the item is not sold separately or is not sold by Multiquip. Other entries will be clarified in the “Remarks” Column.

QTY. Column

Numbers Used — Item quantity can be indicated by a number, a blank entry, or A/R.

A/R (As Required) is generally used for hoses or other parts that are sold in bulk and cut to length.

A blank entry generally indicates that the item is not sold separately. Other entries will be clarified in the “Remarks” Column.

REMARKS Column

Some of the most common notes found in the “Remarks” Column are listed below. Other additional notes needed to describe the item can also be shown.

Assembly/Kit — All items on the parts list with the same unique symbol will be included when this item is purchased.

Indicated by:

“INCLUDES ITEMS W/(unique symbol)”

Serial Number Break — Used to list an effective serial number range where a particular part is used.

Indicated by:

“S/N XXXXX AND BELOW”

“S/N XXXX AND ABOVE”

“S/N XXXX TO S/N XXX”

Specific Model Number Use — Indicates that the part is used only with the specific model number or model number variant listed. It can also be used to show a part is NOT used on a specific model or model number variant.

Indicated by:

“XXXXX ONLY”

“NOT USED ON XXXX”

“Make/Obtain Locally” — Indicates that the part can be purchased at any hardware shop or made out of available items. Examples include battery cables, shims, and certain washers and nuts.

“Not Sold Separately” — Indicates that an item cannot be purchased as a separate item and is either part of an assembly/kit that can be purchased, or is not available for sale through Multiquip.

SUGGESTED SPARE PARTS

QP2TH TRASH PUMP WITH HONDA GX160K1QX2/GX160U1QX2/ GX160UT2QX2 ENGINES

1 to 3 units

Qty.	P/N	Description
1.....	1889040030.....	IMPELLER
1.....	0811345443.....	MECHANICAL SEAL SLEEVE
2.....	0803442930.....	MECHANICAL SEAL
2.....	0631211159.....	CAP, FLOODING
2.....	0481571950.....	O-RING, DRAIN COVER
2.....	0489402910.....	O-RING, CASING
2.....	0482200180.....	O-RING, MECHANICAL SEAL SLEEVE
4.....	0852833020.....	ADJUST LINER .30
4.....	0852853020.....	ADJUST LINER .50
3.....	17210ZE2515.....	ELEMENT, AIR CLEANER, GX160K1QX2/GX160U1QX2
3.....	17210ZE1517.....	ELEMENT, AIR CLEANER, GX160UT2QX2
3.....	9807956846.....	SPARK PLUG
1.....	28462ZE2W11.....	ROPE, RECOIL STARTER, GX160K1QX2/GX160U1QX2
1.....	28462ZH8003.....	ROPE, RECOIL STARTER, GX160UT2QX2
1.....	17620ZH7023.....	CAP, WITH GASKET, FUEL FILLER, GX160K1QX2/GX160U1QX2
1.....	17620Z4M000.....	CAP, WITH GASKET FUEL FILLER, GX160UT2QX2

NOTICE

Part numbers on this Suggested Spare Parts list may supersede/replace the part numbers shown in the following parts lists.

PUMP ASSEMBLY

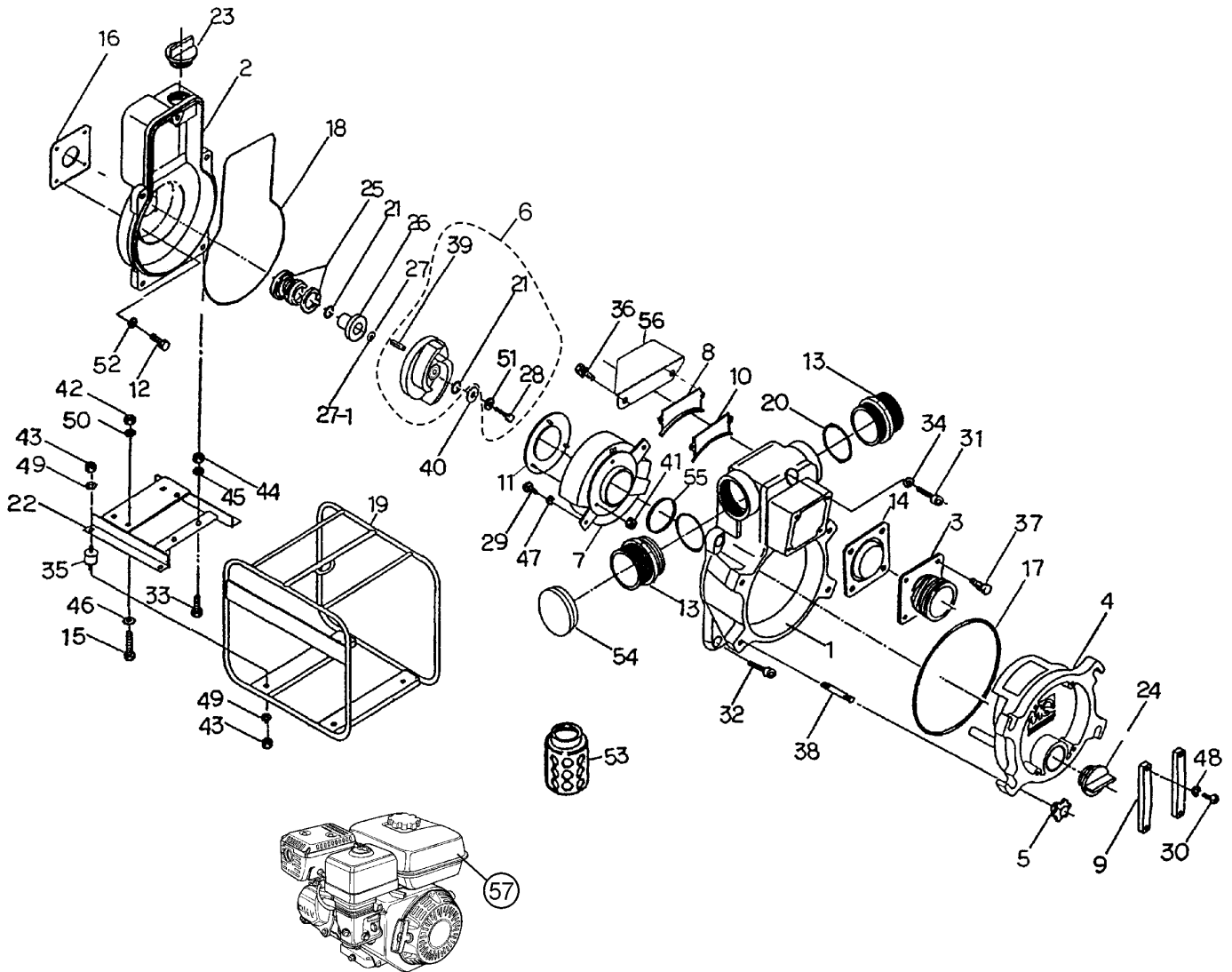

PUMP ASSEMBLY

<u>NO.</u>	<u>PART NO.</u>	<u>PART NAME</u>	<u>QTY.</u>	<u>REMARKS</u>
1	1889100011	CASING	1	
2	1889100020	CASING COVER	1	
3	18890001600014	SUCTION COVER	1	
4	1889100171	DRAIN COVER	1	
5	19920002200014	DRAIN COVER HANDLE	4	
6	1889040031	ASSY IMPELLER KIT.....	1	INCLUDES ITEMS W/ #
7	1889000132	VOLUTE CASING	1	
8	1889100741	SUCTION PLATE	1	
9	1247100250	DRAIN COVER SET HANDLE	2	
10	1889330410	SUCTION PLATE PACKING	1	
11	1992250700	WEAR PLATE	1	
12	0191190525	BOLT(CASING COVER), 5/16-24 UNF	4	
13	07904320200014	NIPPLE, NPS2" X NPT2"	2	
14	1889350351	CHECK VALVE	1	
15	0105090840	BOLT (ENGINE), M8 X40	4	
16	1211390610	CASING COVER PACKING, OIL SHEET	1	
17	0481571950	O'RING (DRAIN COVER)	1	
18	0489402910	O'RING (CASING), 4 X 291 MM	1	
19	1889214010P002	BASE, SS400	1	
20	0481310550	O-RING (NIPPLE)	2	
21#	0482200180	O-RING" (MECHANICAL SEAL SLEEVE)	2	
22	18892140200014	ENGINE BASE, SS400	1	
23	0631211159	FLOODING CAP, PF1-1/2"	1	
24	0631211159	DRAIN CAP, PF1-1/2"	1	
25	0803442930	MECHANICAL SEAL	1	
26	0811345443	MECHANICAL SEAL SLEEVE, DIA. 25MM	1	
27	0852833020	ADJUST LINER DIA. 20 X 30 MM T0.3	1	
27-1	0852853020	ADJUST LINER DIA. 20 X 30 MM T0.5	1	
28#	0191190544	BOLT(IMPELLER), 5/16-24 UNF X 1-3/4.....	1	REPLACES P/N 0191190525
29	0131190820	SCREW (VOLUTE CASING) M8 X 20.....	2	REPLACES P/N 0141090820QP2
30	0141090825	SCREW (DRAIN COVER SET HANDLE) M8 X 25	4	
31	0131191270	CAP SCREW (CASING), M12 X 70	1	
32	0131191235	CAP SCREW (CASING), M12 X 35	4	
33	0105091035	BOLT (PUMP), M10 X 35	2	
34	0459220120	SEAL WASHER (CASING) M12	1	
35	0723302040	CUSHION RUBBER, 40 X 20 M10	4	
36	0181090820	BOLT SET W/SPRING WASHER M8 X 20 (SUCTION PLATE)	2	
37	0181090825	BOLT SET WITH SPRING WASHER M8 X 25	4	

NOTICE

Item 21, O-ring, is included in impeller kit, item 6. When ordered as part of the kit, quantity of o-ring is one. Replacement of impeller requires two o-rings, so it is necessary to order one additional o-ring.

PUMP ASSEMBLY

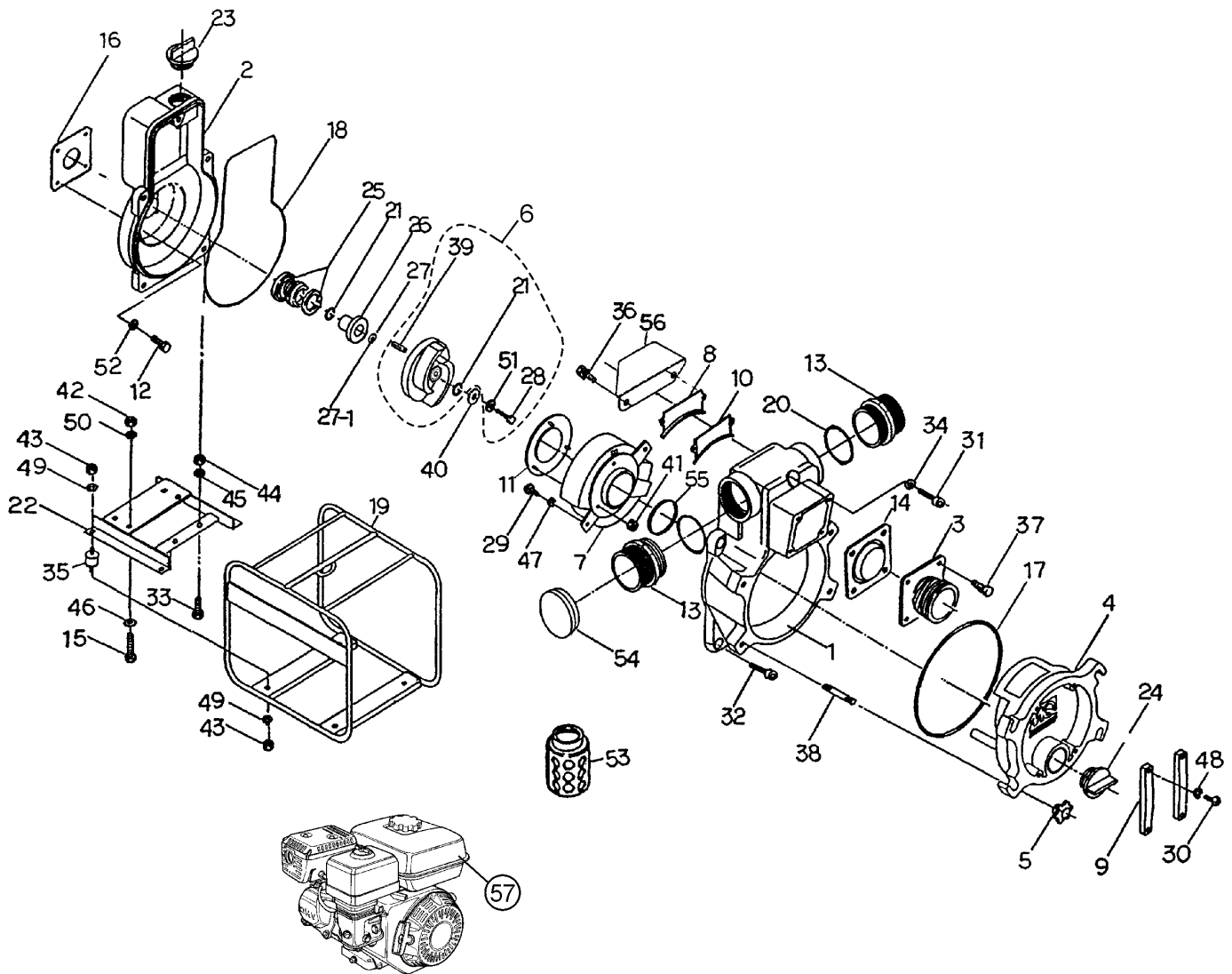

PUMP ASSEMBLY

<u>NO.</u>	<u>PART NO.</u>	<u>PART NAME</u>	<u>QTY.</u>	<u>REMARKS</u>
38	0151191257	STUD BOLT, (DRAIN COVER HANDLE) M12 X 57 X15 X 22	4	
39#	0520030310	KEY, 4.7 X21 MM.....	1	REPLACES P/N 0520030413
40	43592012400011	IMPELLER WASHER, DIA. 35 X 9 MM T4.5	1	
41	0204490060	U-NUT, WEAR PLATE M6	3	
42	0205490080	NUT, ENGINE M8	4	
43	0205490100	NUT, CUSHION RUBBER M10	8	
44	0205490100	NUT, PUMP M10	2	
45	0451290100	SPRING WASHER, PUMP M10	2	
46	0401650080	WASHER, ENGINE M8	4	
47	0457290080	SPRING WASHER, (VOLUTE CASING)M8	2	
48	0451290080	SPRING WASHER, (DRAIN COVER SET M8	4	
49	0451290100	SPRING WASHER, (CUSHION RUBBER) M10	8	
50	0451290080	SPRING WASHER, (ENGINE) M8	4	
51#	0458220080	SPRING WASHER, (IMPELLER), M8	1	REPLACES P/N 0451290080
52	0451290080	SPRING WASHER, (CASING COVER) M8	4	
53	0742214050	STRAINER	1	
54	1889108050	CAP	1	
55	0481310700	O-RING	1	
56	1889250770	OVERFLOW SUPPRESSOR	1	
57	GX160K1QX2	ENGINE, HONDA 5.5 HP	1	S/N 2TH-3428 AND BELOW
57	GX160U1QX2	ENGINE, HONDA 5.5 HP	1	S/N 2TH-3429 TO 2TH-13438
57	GX160UT2QX2	ENGINE, HONDA 5.5 HP	1	S/N 2TH-13439 AND ABOVE

ENGINE SERVICE PARTS

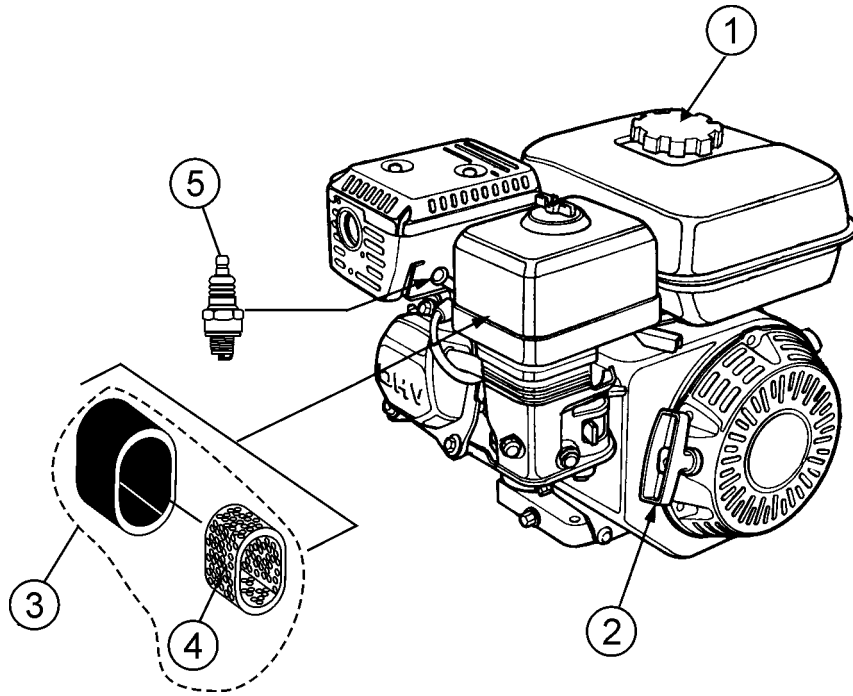

ENGINE SERVICE PARTS

<u>NO.</u>	<u>PART NO.</u>	<u>PART NAME</u>	<u>QTY.</u>	<u>REMARKS</u>
1	17620ZH7023	CAP, WITH GASKET, FUEL FILLER.....	1.....	GX160K1QX2/GX160U1QX2
1	17620Z4M000	CAP, WITH GASKET, FUEL FILLER.....	1.....	GX160UT2QX2
2	28462ZE2W11	ROPE, RECOIL STARTER	1.....	GX160K1QX2/GX160U1QX2
2	28462ZH8003	ROPE, RECOIL STARTER	1.....	GX160UT2QX2
3	17210ZE2515	ELEMENT, AIR CLEANER	1.....	GX160K1QX2/GX160U1QX2 INCLUDES ITEM W/ #
3	17210ZE1517	ELEMENT, AIR CLEANER	1.....	GX160UT2QX2 INCLUDES ITEM W/ #
4#	17218ZE1507	FILTER, OUTER	1	
5	9807956846	SPARK PLUG	1	

TERMS AND CONDITIONS OF SALE — PARTS

PAYMENT TERMS

Terms of payment for parts are net 30 days.

FREIGHT POLICY

All parts orders will be shipped collect or prepaid with the charges added to the invoice. All shipments are F.O.B. point of origin. Multiquip's responsibility ceases when a signed manifest has been obtained from the carrier, and any claim for shortage or damage must be settled between the consignee and the carrier.

MINIMUM ORDER

The minimum charge for orders from Multiquip is \$15.00 net. Customers will be asked for instructions regarding handling of orders not meeting this requirement.

RETURNED GOODS POLICY

Return shipments will be accepted and credit will be allowed, subject to the following provisions:

1. A Returned Material Authorization must be approved by Multiquip prior to shipment.
2. To obtain a Return Material Authorization, a list must be provided to Multiquip Parts Sales that defines item numbers, quantities, and descriptions of the items to be returned.
 - a. The parts numbers and descriptions must match the current parts price list.
 - b. The list must be typed or computer generated.
 - c. The list must state the reason(s) for the return.
 - d. The list must reference the sales order(s) or invoice(s) under which the items were originally purchased.
 - e. The list must include the name and phone number of the person requesting the RMA.
3. A copy of the Return Material Authorization must accompany the return shipment.
4. Freight is at the sender's expense. All parts must be returned freight prepaid to Multiquip's designated receiving point.

5. Parts must be in new and resalable condition, in the original Multiquip package (if any), and with Multiquip part numbers clearly marked.
6. The following items are not returnable:
 - a. Obsolete parts. (If an item is in the price book and shows as being replaced by another item, it is obsolete.)
 - b. Any parts with a limited shelf life (such as gaskets, seals, "O" rings, and other rubber parts) that were purchased more than six months prior to the return date.
 - c. Any line item with an extended dealer net price of less than \$5.00.
 - d. Special order items.
 - e. Electrical components.
 - f. Paint, chemicals, and lubricants.
 - g. Decals and paper products.
 - h. Items purchased in kits.
7. The sender will be notified of any material received that is not acceptable.
8. Such material will be held for five working days from notification, pending instructions. If a reply is not received within five days, the material will be returned to the sender at his expense.
9. Credit on returned parts will be issued at dealer net price at time of the original purchase, less a 15% restocking charge.
10. In cases where an item is accepted, for which the original purchase document can not be determined, the price will be based on the list price that was effective twelve months prior to the RMA date.
11. Credit issued will be applied to future purchases only.

PRICING AND REBATES

Prices are subject to change without prior notice. Price changes are effective on a specific date and all orders received on or after that date will be billed at the revised price. Rebates for price declines and added charges for price increases will not be made for stock on hand at the time of any price change.

Multiquip reserves the right to quote and sell direct to Government agencies, and to Original Equipment Manufacturer accounts who use our products as integral parts of their own products.

SPECIAL EXPEDITING SERVICE

A \$35.00 surcharge will be added to the invoice for special handling including bus shipments, insured parcel post or in cases where Multiquip must personally deliver the parts to the carrier.

LIMITATIONS OF SELLER'S LIABILITY

Multiquip shall not be liable hereunder for damages in excess of the purchase price of the item with respect to which damages are claimed, and in no event shall Multiquip be liable for loss of profit or good will or for any other special, consequential or incidental damages.

LIMITATION OF WARRANTIES

No warranties, express or implied, are made in connection with the sale of parts or trade accessories nor as to any engine not manufactured by Multiquip. Such warranties made in connection with the sale of new, complete units are made exclusively by a statement of warranty packaged with such units, and Multiquip neither assumes nor authorizes any person to assume for it any other obligation or liability whatever in connection with the sale of its products. Apart from such written statement of warranty, there are no warranties, express, implied or statutory, which extend beyond the description of the products on the face hereof.

Effective: February 22, 2006

OPERATION AND PARTS MANUAL

HERE'S HOW TO GET HELP

PLEASE HAVE THE MODEL AND SERIAL
NUMBER ON-HAND WHEN CALLING

UNITED STATES

Multiquip Corporate Office

18910 Wilmington Ave.
Carson, CA 90746
Contact: mq@multiquip.com

Tel. (800) 421-1244
Fax (310) 537-3927

Service Department

800-421-1244
310-537-3700

Fax: 310-537-4259

Technical Assistance

800-478-1244

Fax: 310-943-2238

MQ Parts Department

800-427-1244
310-537-3700

Fax: 800-672-7877
Fax: 310-637-3284

Warranty Department

800-421-1244
310-537-3700

Fax: 310-943-2249

CANADA

Multiquip

4110 Industriel Boul.
Laval, Quebec, Canada H7L 6V3
Contact: jmartin@multiquip.com

Tel: (450) 625-2244
Tel: (877) 963-4411
Fax: (450) 625-8664

UNITED KINGDOM

Multiquip (UK) Limited Head Office

Unit 2, Northpoint Industrial Estate,
Globe Lane,
Dukinfield, Cheshire SK16 4UJ
Contact: sales@multiquip.co.uk

Tel: 0161 339 2223
Fax: 0161 339 3226

© COPYRIGHT 2014, MULTIQUIP INC.

Multiquip Inc, the MQ logo are registered trademarks of Multiquip Inc. and may not be used, reproduced, or altered without written permission. All other trademarks are the property of their respective owners and used with permission.

This manual MUST accompany the equipment at all times. This manual is considered a permanent part of the equipment and should remain with the unit if resold.

The information and specifications included in this publication were in effect at the time of approval for printing. Illustrations, descriptions, references and technical data contained in this manual are for guidance only and may not be considered as binding. Multiquip Inc. reserves the right to discontinue or change specifications, design or the information published in this publication at any time without notice and without incurring any obligations.

Your Local Dealer is:



Free Manuals Download Website

<http://myh66.com>

<http://usermanuals.us>

<http://www.somanuals.com>

<http://www.4manuals.cc>

<http://www.manual-lib.com>

<http://www.404manual.com>

<http://www.luxmanual.com>

<http://aubethermostatmanual.com>

Golf course search by state

<http://golfingnear.com>

Email search by domain

<http://emailbydomain.com>

Auto manuals search

<http://auto.somanuals.com>

TV manuals search

<http://tv.somanuals.com>