

OPERATION MANUAL



***WHITEMAN* SERIES**
MODEL HTN-27K-TCSL
MODEL HTN-28K-TCSL
RIDE ON TROWEL
(KOHLEK GASOLINE ENGINE)

Revision #0 (06/06/07)

**THIS MANUAL MUST ACCOMPANY
THE EQUIPMENT AT ALL TIMES.**

P/N 21565



WARNING



CALIFORNIA — Proposition 65 Warning

Engine exhaust and some of its constituents, and some dust created by power sanding, sawing, grinding, drilling and other construction activities contains chemicals known to the State of California to cause cancer, birth defects and other reproductive harm. Some examples of these chemicals are:

- Lead from lead-based paints.
- Crystalline silica from bricks.
- Cement and other masonry products.
- Arsenic and chromium from chemically treated lumber.

Your risk from these exposures varies, depending on how often you do this type of work. To reduce your exposure to these chemicals: **ALWAYS** work in a well ventilated area, and work with approved safety equipment, such as dust masks that are specially designed to filter out microscopic particles.

WARNING



SILICOSIS WARNING

Grinding/cutting/drilling of masonry, concrete, metal and other materials with silica in their composition may give off dust or mists containing crystalline silica. Silica is a basic component of sand, quartz, brick clay, granite and numerous other minerals and rocks. Repeated and/or substantial inhalation of airborne crystalline silica can cause serious or fatal respiratory diseases, including silicosis. In addition, California and some other authorities have listed respirable crystalline silica as a substance known to cause cancer. When cutting such materials, always follow the respiratory precautions mentioned above.

WARNING



RESPIRATORY HAZARDS

Grinding/cutting/drilling of masonry, concrete, metal and other materials can generate dust, mists and fumes containing chemicals known to cause serious or fatal injury or illness, such as respiratory disease, cancer, birth defects or other reproductive harm. If you are unfamiliar with the risks associated with the particular process and/or material being cut or the composition of the tool being used, review the material safety data sheet and/or consult your employer, the material manufacturer/supplier, governmental agencies such as OSHA and NIOSH and other sources on hazardous materials. California and some other authorities, for instance, have published lists of substances known to cause cancer, reproductive toxicity, or other harmful effects.

Control dust, mist and fumes at the source where possible. In this regard use good work practices and follow the recommendations of the manufacturers or suppliers, OSHA/NIOSH, and occupational and trade associations. Water should be used for dust suppression when wet cutting is feasible. When the hazards from inhalation of dust, mists and fumes cannot be eliminated, the operator and any bystanders should always wear a respirator approved by NIOSH/MSHA for the materials being used.

MQ WHITEMAN — HTN-SERIES RIDE-ON POWER TROWEL

Proposition 65 Warning	2
Silicosis/Respiratory Warnings	3
Table of Contents	4
Parts Ordering Procedures	5
Training Checklist	6
Daily Pre-Operation Checklist	7
Safety Message Alert Symbols	8-9
Rules For Safe Operation	10-13
Operation And Safety Decals	14
Specifications	15
Engine Specifications	16
General Information	17
Controls and Indicators	18-19
Basic Engine	20
New Machine Setup Instructions	21
Initial Start-Up	22
Operation	23-24
Maintenance	25-38
Engine Troubleshooting.....	39-40
Troubleshooting (Trowel)	41-42
Terms And Conditions Of Sale	44

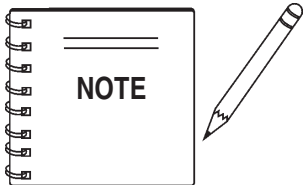

Specifications and part numbers are subject to change without notice.

www.multiquip.com

**Ordering parts has never been easier!
Choose from three easy options:**



Order via Internet (Dealers Only):

Order parts on-line using Multiquip's SmartEquip website!

- View Parts Diagrams
- Order Parts
- Print Specification Information



If you have an MQ Account, to obtain a Username and Password, E-mail us at: parts@multiquip.com.

To obtain an MQ Account, contact your District Sales Manager for more information.

Goto www.multiquip.com and click on

Order Parts to log in and save!

Use the **internet** and qualify for a **5% Discount** on *Standard orders* for all orders which include complete part numbers.*

Note: Discounts Are Subject To Change



Order via Fax (Dealers Only):

All customers are welcome to order parts via Fax.

Domestic (US) Customers dial:
1-800-6-PARTS-7 (800-672-7877)

Fax your order in and qualify for a **2% Discount** on *Standard orders* for all orders which include complete part numbers.*

Note: Discounts Are Subject To Change



Order via Phone: Domestic (US) Dealers Call:
1-800-427-1244

Non-Dealer Customers:

Contact your local Multiquip Dealer for parts or call 800-427-1244 for help in locating a dealer near you.



International Customers should contact their local Multiquip Representatives for Parts Ordering information.

When ordering parts, please supply:

- | | |
|--|--|
| <ul style="list-style-type: none"> <input type="checkbox"/> Dealer Account Number <input type="checkbox"/> Dealer Name and Address <input type="checkbox"/> Shipping Address (if different than billing address) <input type="checkbox"/> Return Fax Number <input type="checkbox"/> Applicable Model Number <input type="checkbox"/> Quantity, Part Number and Description of Each Part | <ul style="list-style-type: none"> <input type="checkbox"/> Specify Preferred Method of Shipment: <ul style="list-style-type: none"> <input checked="" type="checkbox"/> UPS/Fed Ex <input checked="" type="checkbox"/> DHL ■ Priority One <input checked="" type="checkbox"/> Truck ■ Ground ■ Next Day ■ Second/Third Day |
|--|--|

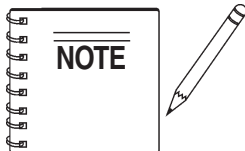

All orders are treated as *Standard Orders* and will ship the same day if received prior to 3PM PST.

WE ACCEPT ALL MAJOR CREDIT CARDS!



TRAINING CHECKLIST

TRAINING CHECKLIST

This checklist lists some of the minimum requirements for machine operation. Please feel free to make copies for daily use. Use this checklist when training a new operator or use as a review for more experienced operators.

TRAINING CHECKLIST			
NO.	DESCRIPTION	OK?	DATE
1	Read Operator's Manual completely.		
2	Machine layout, location of components, checking of engine and fluid levels.		
3	Fuel system, refueling procedure.		
4	Operation of spray and lights.		
5	Operation of controls (machine not running).		
6	Safety controls, Safety Stop Switch operation.		
7	Emergency stop procedures.		
8	Startup of machine.		
9	Maintaining a hover.		
10	Maneuvering.		
11	Pitching.		
12	Matching blade pitch between towers Twin Pitch™, disengaging the linkage.		
13	Concrete finishing techniques.		
14	Shutdown of machine.		
15	Lifting of machine (lift loops).		
16	Machine transport and storage.		

Operator _____ Trainee _____

COMMENTS:

DAILY PRE-OPERATION CHECKLIST

DAILY PRE-OPERATION CHECKLIST

DAILY PRE-OPERATION CHECKLIST		✓	✓	✓	✓	✓	✓
1	Engine Oil Level.						
2	Gearbox Fluid Level.						
3	Radiator Coolant Level.						
4	Condition of Blades.						
5	Blade Pitch Operation.						
6	Safety-Stop Switch Operation.						
7	Steering Control Operation.						
8	Condition of Belts.						

COMMENTS:

HTN-SERIES — SAFETY MESSAGE ALERT SYMBOLS

FOR YOUR SAFETY AND THE SAFETY OF OTHERS!

Safety precautions should be followed at all times when operating this equipment. Failure to read, understand and comply with the Safety Messages and Operating Instructions could result in injury to yourself and others.

This Operation Manual has been developed to provide instructions for the safe and efficient operation of the HTN - Series Ride-On Trowel. For engine maintenance information, please refer to the engine manufacturer's instructions for data relative to its safe operation.



Before using this Ride-On Trowel, ensure that the operating individual has read, understands, and complies with all instructions in this manual.

SAFETY MESSAGE ALERT SYMBOLS

The three (3) Safety Messages shown below will inform you about potential hazards that could injure you or others. The Safety Messages specifically address the level of exposure to the operator, and are preceded by one of three words: **DANGER**, **WARNING**, or **CAUTION**.

DANGER

You **WILL** be **KILLED** or **SERIOUSLY INJURED** if you **DO NOT** follow these directions.

WARNING

You **CAN** be **KILLED** or **SERIOUSLY INJURED** if you **DO NOT** follow these directions.

CAUTION

You **CAN** be **INJURED** if you **DO NOT** follow these directions.

Potential hazards associated with trowel operation will be referenced with Hazard Symbols which appear throughout this manual, and will be referenced in conjunction with Safety Message Alert Symbols.

HAZARD SYMBOLS

Lethal Exhaust Gases



Engine exhaust gases contain poisonous carbon monoxide. This gas is colorless and odorless, and can cause death if inhaled. **NEVER** operate this equipment in a confined area or enclosed structure that does not provide ample free flow air.

Explosive Fuel

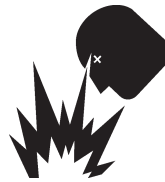

Gasoline is extremely flammable, and its vapors can cause an explosion if ignited. **DO NOT** start the engine near spilled fuel or combustible fluids. **DO NOT** fill the fuel tank while the engine is running or hot. **DO NOT** overfill tank, since spilled fuel could ignite if it comes into contact with hot engine parts or sparks from the ignition system. Store fuel in approved containers, in well-ventilated areas and away from sparks and flames. **NEVER** use fuel as a cleaning agent.

Burn Hazards



Engine components can generate extreme heat. To prevent burns, **DO NOT** touch these areas while the engine is running or immediately after operations. **NEVER** operate the engine with heat shields or heat guards removed.

Rotating Parts



NEVER operate equipment with covers, or guards removed. Keep **fingers, hands, hair** and **clothing** away from all moving parts to prevent injury.

HTN-SERIES — SAFETY MESSAGE ALERT SYMBOLS



Accidental Starting

Accidental starts can cause severe injury or death. **ALWAYS** place the ON/OFF switch in the OFF position. Disconnect and ground spark plug lead and disconnect negative battery cable from battery before servicing.



Over Speed Conditions



NEVER tamper with the factory settings of the engine governor or settings. Personal injury and damage to the engine or equipment can result if operating in speed ranges above maximum allowable.



Respiratory Hazard



ALWAYS wear approved respiratory protection.



Sight and Hearing hazard

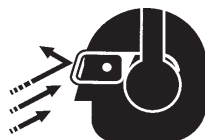

ALWAYS wear approved eye and hearing protection.



Equipment Damage Messages

Other important messages are provided throughout this manual to help prevent damage to your trowel, other property, or the surrounding environment.



CAUTION

This *Ride-On trowel*, other property, or the surrounding environment could be damaged if you do not follow instructions.

HTN-SERIES — RULES FOR SAFE OPERATION

RULES FOR SAFE OPERATION

WARNING

Failure to follow instructions in this manual may lead to serious injury or even death! This equipment is to be operated by trained and qualified personnel only! This equipment is for industrial use only.

The following safety guidelines should always be used when operating the HTN-Series Ride-On Trowel.

SAFETY

- **DO NOT** operate or service this equipment before you read, understand, and comply with all safety messages in this manual. The manual must be kept available and accessible to the operator.



- This equipment should not be operated by persons under the minimum statutory age limit.
- **NEVER** use this machine for any purpose other than those described in this manual.
- **NEVER** operate the trowel without proper protective clothing, shatterproof glasses, steel-toed boots and other protective devices required for the job.



- **NEVER** use accessories or attachments which are not recommended by Multiquip for this equipment. Damage to the equipment and/or injury to user may result.
- Manufacturer does not assume responsibility for any accident due to equipment modifications. Unauthorized equipment modification will void all warranties. Any modification which could lead to a change in the original characteristics of the machine should be made only by the manufacturer who shall confirm that the machine is in conformity with appropriate safety regulations.

- **NEVER** operate this equipment when not feeling well due to fatigue, illness or taking medicine.
- **NEVER** operate the trowel under the influence of drugs or alcohol.
- Replace nameplate, operation and safety decals when they become difficult to read.
- **ALWAYS** check the trowel for loosened hardware such as nuts and bolts before starting.
- **NEVER** touch the hot exhaust manifold, muffler or cylinder. Allow these parts to cool before servicing the trowel. Contact with **hot!** components can cause serious burns.



- The engine of this trowel requires an adequate free flow of cooling air. **NEVER** operate the trowel in any enclosed or narrow area where free flow of the air is restricted. If the air flow is restricted it will cause serious damage to the engine and may cause injury to people. Remember the engine gives off **DEADLY** carbon monoxide gas.

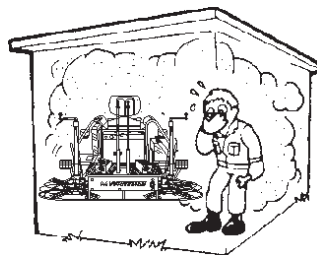

- **ALWAYS** refuel in a well-ventilated area, away from sparks and open flames.
- Topping-off to filler port is dangerous, as it tends to spill fuel.
- **NEVER** use fuel as a cleaning agent.
- **ALWAYS** use extreme caution when working with **flammable** liquids. When refueling, **STOP** the engine. Allow the engine to cool before adding fuel or performing service and maintenance functions.
- **NEVER** operate the trowel in an explosive atmosphere where fumes are present, or near combustible materials. An explosion or fire could result in severe **bodily harm or even death**.
- **NEVER** **smoke** around or near the machine. Fire or explosion could result from **fuel vapors**, or if fuel is spilled on a **hot!** engine.

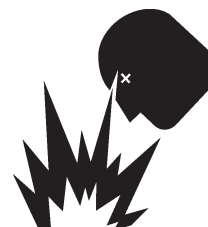

HTN-SERIES — RULES FOR SAFE OPERATION

- **NEVER** run engine without air filter. Severe engine damage may occur. Service air filter frequently to prevent carburetor malfunction.
- **NEVER** place your **feet** or **hands** inside the guard rings while starting or operating this equipment.
- **AVOID** wearing jewelry or loose fitting clothing that may snag on the controls or moving parts as this can cause a serious injury.
- **ALWAYS** keep clear of **rotating** or **moving parts** while operating the trowel.
- **Moving Parts** – Shut down the engine before performing service or maintenance functions. Contact with moving parts can cause serious injury.
- **ALWAYS** check to make sure that the operating area is clear before starting the engine.
- **NEVER** leave the machine **unattended** while running.
- **ALWAYS** be sure the operator is familiar with proper safety precautions and operations techniques before using trowel.
- **ALWAYS** keep the work area well organized.
- **ALWAYS** clear the work area of any debris, tools, etc. that would constitute a hazard while the trowel is in operation.

WARNING

ALWAYS check to make sure that the operating area is clear before starting the engine.

- No one other than the operator is to be in the working area when the trowel is in operation.
- **NEVER** allow passengers or riders on the trowel during operation.
- Always observe all applicable compulsory regulations relevant to environmental protection, especially, fuel storage, the handling of hazardous substances, and the wearing of protective clothing and equipment. Instruct the user as necessary, or, as the user, request this information and training.
- **ALWAYS** store equipment properly when it is not being used. Equipment should be stored in a clean, dry location out of the reach of children.

DANGER

Pay close attention to ventilation when operating the trowel in confined spaces such as tunnels, buildings or similar areas. The engine exhaust contains harmful elements. Ensure proper air flow to move engine exhaust away from the operator.



Lifting the Ride-On Trowel

CAUTION

This ride-on trowel is very **heavy** and awkward to move around. Use proper heavy lifting procedures and **DO NOT** attempt to lift the ride-on trowel by the guard rings.

The HTN-Series Ride-On Power Trowel is designed to be moved and handled several ways.

The easiest way to lift the trowel is to utilize the lift loops that are welded to the frame. These lift loops are located to the left and right sides of the operator's seat.

A strap or chain can be attached to these lift loops, allowing a forklift or crane to lift the trowel up onto and off of a slab of concrete. The strap or chain should have a minimum 2,000 pounds (1000-kg) lifting capacity and the lifting gear must be capable of lifting at least this amount.

DANGER

NEVER stand under or allow anyone else to stand under the trowel while it is being lifted.



HTN-SERIES — RULES FOR SAFE OPERATION

Transporting

- **ALWAYS** shutdown engine before transporting.
- Tighten fuel tank cap securely and close fuel petcock to prevent fuel from spilling.
- Drain fuel when transporting trowel for long distances or over bad roads.
- When placing the trowel on a truck-bed for transport, **always** tie-down the trowel.
- If the trowel is being transported via a trailer, make sure the trailer complies with all local and state safety transportation laws. Refer to the following "**Towing Safety Precautions**" for basic towing techniques.

Towing Safety Precautions

CAUTION

Conform to **Department of Transportation (DOT) Safety Towing Regulations** before transporting trowel on public roads.

To reduce the possibility of an accident while transporting the trowel on public roads, always make sure the trailer that supports the trowel and the towing vehicle are in good operating condition and both units are mechanically sound.

The following list of suggestions should be used when towing your trowel:

- Make sure the hitch and coupling of the towing vehicle are rated equal to, or greater than the trailer "gross vehicle weight rating" (GVWR) of 6,000 lbs.
- **ALWAYS** inspect the hitch and coupling for wear. **NEVER** tow a trailer with defective hitches, couplings, chains, etc.
- Check the tire air pressure on both towing vehicle and trailer. **Trailer tires should be inflated to 50 psi cold.** Also check the tire tread wear on both vehicles.
- **ALWAYS** make sure the trailer is equipped with "**Safety Chains**".
- **ALWAYS** attach trailer's safety chains to towing vehicle properly.
- **ALWAYS** make sure the vehicle and trailer directional, backup, brake, and trailer lights are connected and working
- **DO NOT** exceed the recommended highway speed when towing. Unless posted otherwise, do not exceed 45 MPH highway, and 10 MPH off-road.

- Use chock-blocks at each wheel when parked to prevent trailer from rolling.
- Use the trailer's swivel jack to adjust the trailer height to a level position while parked.
- Avoid sudden stops and starts. This can cause the trailer to skid or jack-knife. Smooth, gradual starts and stops will improve towing.
- Avoid sharp turns.
- Trailer should be adjusted to a level position at all times when towing.
- Raise and lock trailer wheel stand in the "**UP**" position when transporting.
- DOT requirements include the following:
 - Connect and test electric brake operation.
 - Secure portable power cables in cable tray with tie wraps.

Battery

The battery contains acids that can cause injury to the eyes and skin. To avoid eye irritation, **always** wear safety glasses or face shielding. Use well insulated gloves when picking the battery up. Use the following guidelines when handling the battery.

- **DO NOT** drop the battery. Any impact to the battery may cause it to explode.
- **DO NOT** expose the battery to open flames, sparks, lit cigarettes etc. The battery contains combustible gases and liquids. If these gases and liquids come in contact with a flame or spark an explosion can occur.
- **ALWAYS** keep the battery charged. If the battery is not charged a buildup of combustible gas will occur.
- **ALWAYS** keep battery cables in good working condition. Repair or replace all worn cables.
- **ALWAYS** disconnect the **negative battery terminal** before performing service on the trowel.
- **ALWAYS** recharge the battery in a vented air environment to avoid risk of a dangerous concentration of combustible gases.
- In case the battery liquid, (dilute sulfuric acid), comes in contact with **clothing or skin**, rinse skin or clothing immediately with plenty of water.
- In case the battery liquid, (dilute sulfuric acid), comes in contact with your **eyes**, rinse eyes immediately with plenty of water, then contact the nearest doctor or hospital and seek medical attention.

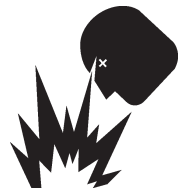

HTN-SERIES — RULES FOR SAFE OPERATION

Maintenance Safety

- **ALWAYS** shut down the engine and disconnect battery before performing service or maintenance functions. Contact with moving parts can cause serious injury.
- Securely support any trowel components that must be raised.
- **NEVER** lubricate components or attempt service on a running trowel.
- **ALWAYS** allow the trowel a proper amount of time to cool before servicing.
- Keep the trowel in proper running condition.
- Make sure that there is no buildup of concrete, grease, oil or debris on the machine.
- Repair damage to the trowel immediately and always replace broken parts.
- Dispose of hazardous waste properly. Examples of potentially hazardous waste are used motor oil, fuel and fuel filters.
- **DO NOT** use plastic food containers to dispose of hazardous waste.
- **DO NOT** pour waste oil or fuel directly onto the ground, down a drain or into any water source.
- **NEVER** store trowel with fuel in the tank for any extended period of time. Always clean up spilled fuel immediately.

Emergencies

- **ALWAYS** know the location of the nearest **fire extinguisher**.



- **ALWAYS** know the location of the nearest **first aid kit**.



- Know the phone numbers of the nearest **ambulance, doctor** and **fire department**. Ensure that a phone or radio is readily available at the jobsite. If this is not possible, know the location of the nearest phone. This information will be invaluable in the event of an emergency.



HTN-SERIES — OPERATION AND SAFETY DECALS

Machine Safety Decals

The HTN-SERIES Ride-On Power Trowel is equipped with a number of operation and safety decals. These decals are provided for operator safety and maintenance information. Should any of these decals become unreadable, replacements can be obtained from your dealer.



P/N 35137



P/N 1499 RED TEXT



P/N 10818 WHITE TEXT 24" x 3"



P/N 20923



P/N: 21455

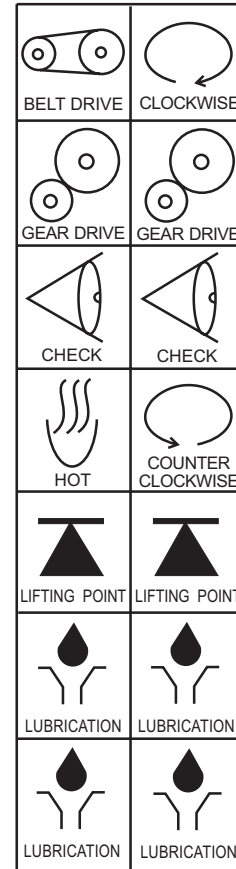

P/N: 11246



P/N 2814 (WHITE)



P/N 35168



P/N 36099 (ISO Blue)



CONTACT SERVICE DEPARTMENT



P/N 20953



P/N 20936

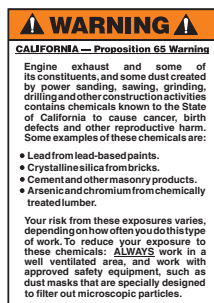

P/N 20525



P/N 2634

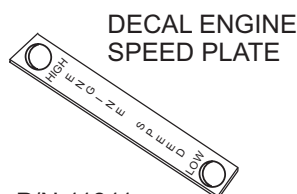

P/N 11811



P/N: 13118

HTN-SERIES— SPECIFICATIONS (TROWEL)

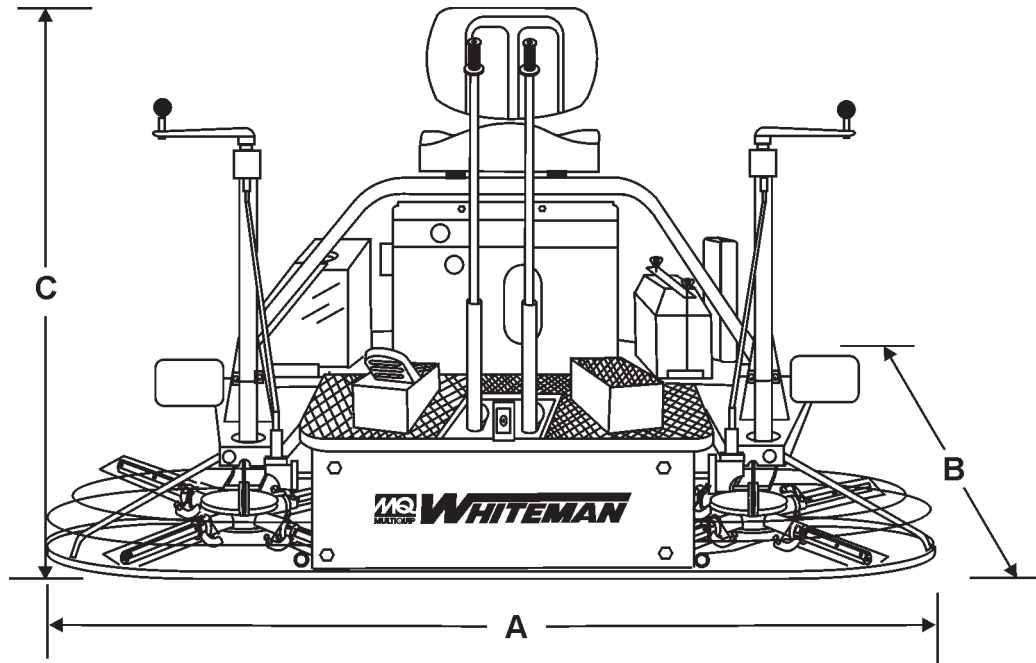

Figure 1. HTN-SERIES Dimensions

Table 1. HTN-Series Specifications

Model	HTN27KTCSL	HTN28KTCSL
A—Length – in. (cm)	95.0 (241.3)	95.0 (241.3)
B—Width – in. (cm)	48.0 (122)	48.0 (122)
C—Height – in. (cm)	46.0 (116.8)	46.0 (116.8)
Weight – lbs. (kgs.) Operating	705 (320.5)	705 (320.5)
Weight – lbs. (kgs.) Shipping	1130 (513.6)	1130 (513.6)
Rotor – RPM (Dry Concrete)	150	150
Path Width – in. (cm)	91 (231)	91 (231)
Hand/Arm Vibration ¹	9.15 ft/s ² (2.79 m/s ²)	7.84 ft/s ² (2.39 m/s ²)
Whole Body Vibration	not available	not available
Sound Pressure (A-Weighted) ²	90 dB(A)	93 dB(A)

NOTE:

1. The vibration level indicated is the maximum RMS (Root Mean Square) value obtained at the handle grip while operating the walk-behind trowel at full throttle on steel plate with blades partially pitched.
2. Sound pressure is a weighted measure. It is measured at the operator's ear position while the walk-behind trowel is operating at full throttle on concrete in a manner most often experienced in "**normal**" circumstances. Sound pressure may vary depending upon the condition of the concrete.

HTN-SERIES— SPECIFICATIONS (ENGINE)

Table 2. HTN-Series Engine Specifications

Model	HTN27KTCSL Kohler 27 HP Engine	HTN28KTCSL Kohler 28 HP EFI Engine
Type	4 Stroke, Overhead Valve V-Twin, gasoline engine.	4 Stroke, Overhead Valve V-Twin, EFI, gasoline engine.
Piston Displacement	44.0 cu.in. (725 cc)	44.0 cu.in. (725 cc)
Max. Output	27 bhp/3200 rpm (20.1 KW)	28 bhp/3200 rpm (20.9 KW)
Max. Torque	42.7 lbf-ft at 2200 rpm	42.7 lbf-ft at 2200 rpm
Cooling System	Forced Air	Forced Air
Engine Oil Capacity	1.75 qt. (1.6 liters) 2.1 qt. (1.9 liters w/oil filter replacement)	1.75 qt. (1.6 liters) 2.1 qt. (1.9 liters w/oil filter replacement)
Fuel Tank	5 gal.(19.23 liters)	5 gal.(19.23 liters)
Gear Box Oil Capacity	69 oz. (2.041 L) Multiquip p/n 20111 (Mobil SCH 634 ISO VG640)	69 oz. (2.041 L) Multiquip p/n 20111 (Mobil SCH 634 ISO VG640)
Fuel	Unleaded gasoline Octane rating of 86 or higher	Unleaded gasoline Octane rating of 86 or higher
Starting System	Electric Start/Transistorized Magneto	Electric Start/Transistorized Magneto
Spark Plug Type	see engine owner's manual	see engine owner's manual
Spark Plug Gap	see engine owner's manual	see engine owner's manual

HTN SERIES Ride-On Power Trowel Familiarization

The HTN SERIES Ride-On Power Trowel is designed for the floating and finishing of concrete slabs.

Take a walk around your trowel. Take notice of all the major components (see Figures 2 and 3, pages 18 and 19) like the engine, blades, air cleaner, fuel system, fuel shut-off valve, ignition switch etc. Ensure engine and gearbox oil levels are within proper operating range.

Read all the safety instructions carefully. Safety instructions will be found throughout this manual and on the machine. Keep all safety information in good, readable condition. Operators should be well trained on the operation and maintenance of the trowel.

Look at the operator control levers. Grasp the control levers and move them around a bit. Observe how moving the control levers cause the gearboxes and frame to move.

Notice the foot pedal which controls the engine and blade speed. Also take a look at the main driveline of the trowel. Take note and reference how the belts look, this is the way the belts should look when adjusted properly.

Before using your trowel, test it on a flat watered down section of finished concrete. This trial test run will increase your confidence in using the trowel and at the same time it will familiarize you with the trowel's controls and indicators. In addition you will understand how the trowel will handle under actual conditions.

Engine

This trowel is equipped with an air cooled 27HP or 28HP EFI Kohler gasoline engine. Refer to the engine owner's manual for specific instructions regarding engine operation. This manual is included with the trowel at the time of shipping. Please contact your nearest Multiquip Dealer if a replacement manual is required.

Blades

The blades of the trowel finish the concrete as they are swirled around the surface. Blades are classified as combination (10 or 8 inches wide) and finish (6 inches wide). This trowel is equipped with four blades per rotor equally spaced in a radial pattern and attached to a vertical rotating shaft by means of a **spider assembly**.

Figures 2 and 3 show the location of the controls, indicators and general maintenance parts. Each control may perform more than one function. The functions of the controls or indicators are on pages 18 and 19.

HTN-SERIES — CONTROLS AND INDICATORS

1. **Seat** – Engine will neither start nor run unless operator is seated.
2. **Steering Control Levers** – Directs the unit forward, reverse, left, or right.
3. **Retardant Spray Control Button** – Sprays retardant through the nozzle at the front of the machine.
4. **Twin Pitch Control** – Both pitch towers are linked together. One crank may be turned to adjust the blade pitch simultaneously or individually controlled for each set of blades. Turn the crank as marked on its top surface to increase or decrease blade pitch.
5. **Light Switch** – Turns on three halogen lights. Two in front one in rear.
6. **Ignition Switch** – With key inserted, turn clockwise to start engine.
7. **Hour Meter** – Indicates number of hours the engine has run.
8. **Choke Control Lever (HTN 27 Only)**– In cold weather pull this lever to start engine. After engine warms push knob all the way in.
9. **Fuel Gauge/Filler Cap** – Indicates the amount of fuel in the fuel tank. Remove this cap to add fuel.
10. **Fuel Tank** – Holds 5 gallons of unleaded gasoline.
11. **Left Foot Riser** – Operator foot rest pedal.
12. **Spray Nozzle** – Spray nozzle for retardant.
13. **Right Foot Pedal** – Controls blade speed. Slow blade speed is accomplished by slightly depressing the foot pedal. Maximum blade speed is accomplished by fully depressing the foot pedal.
14. **EZ- Mover Boss** – Front attachment point for EZ Mover. Used to move the trowel.
15. **Dip Stick** – Access hole provided to check engine oil.
16. **Spark Plug** – Access the spark plug through this cutout.

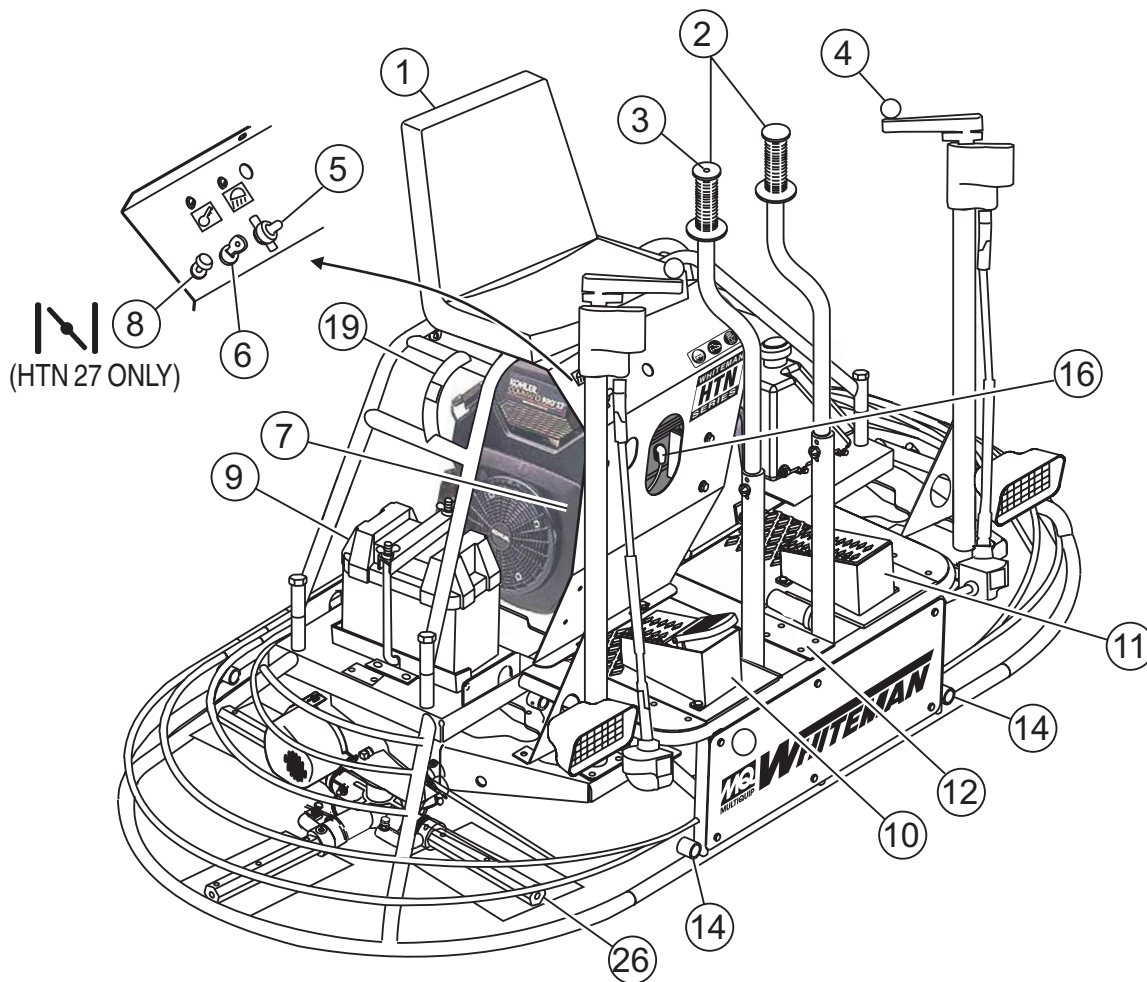
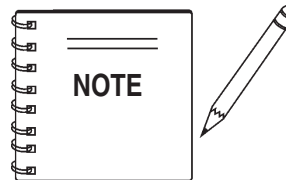

Figure 2. HTN-SERIES Controls and Indicators (Front)

HTN-SERIES — CONTROLS AND INDICATORS

17. **Safety Stop Switch** – Shuts down engine when seat is empty.
18. **Rear Light** – The HTN-SERIES Ride-On Power Trowel has three 12 volt halogen lights.
19. **Lift Loops** – Located on both sides of the main frame. Used to lift the trowel.
20. **Engine Air Filter** – Protects the engine from dirt.
21. **Oil Filter** – Filters the engine oil.
22. **Oil Drain** – Remove the plug from end of hose to drain the engine oil.
23. **Retardant Spray Tank** – Holds 5 gallons of retardant.
24. **Retardant Spray Pump** – Delivers retardant to the spray nozzle.
25. **EZ- Mover Boss** – Rear attachment point for EZ Mover. Used to transport the trowel.
26. **Spiders (Left/Right)** – Consists of trowel arms, blades, wear plate, and thrust collar.
27. **Document Box** – Contains all product documentation.
28. **Battery** – Provides +12V DC power to the electrical system.
29. **Belt Guard** – Encloses drive belt used in conjunction with clutch.
30. **Engine Oil Fill** – Remove this cap to add engine oil.



Read, understand, and comply with all safety messages and operating instructions in this manual before attempting to operate the trowel.

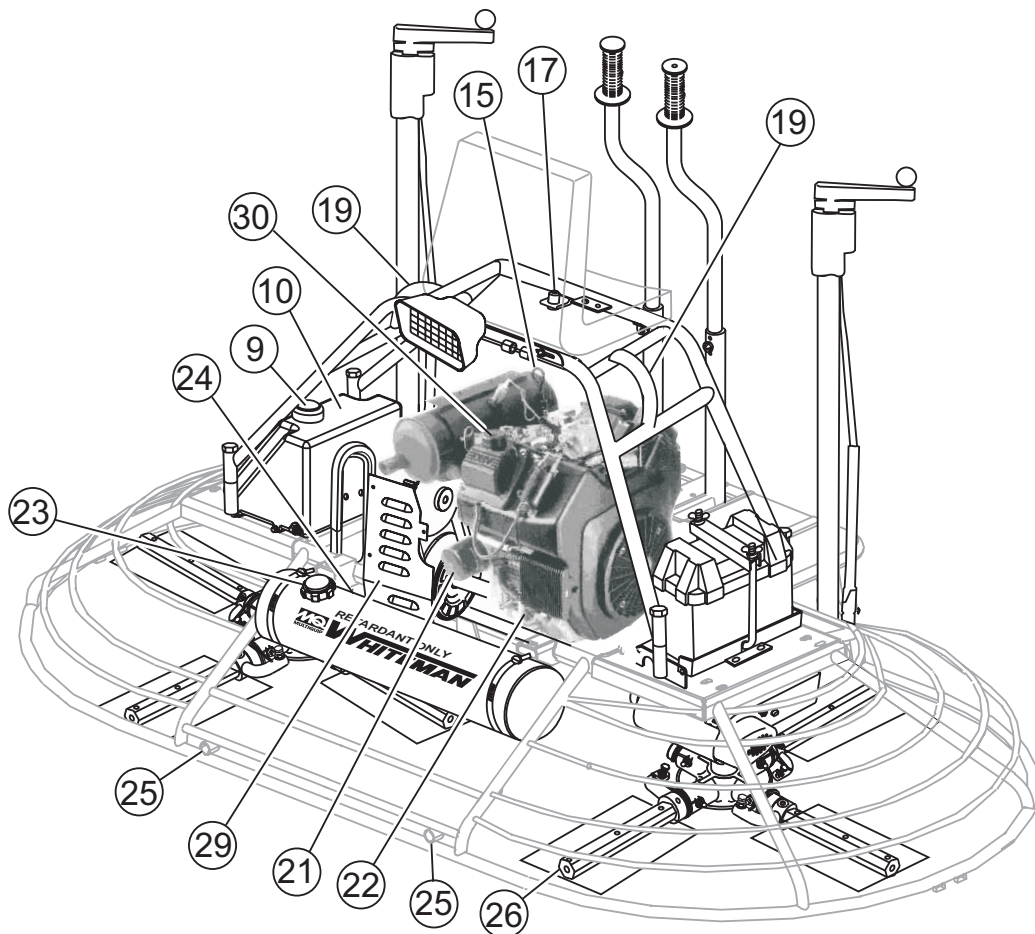
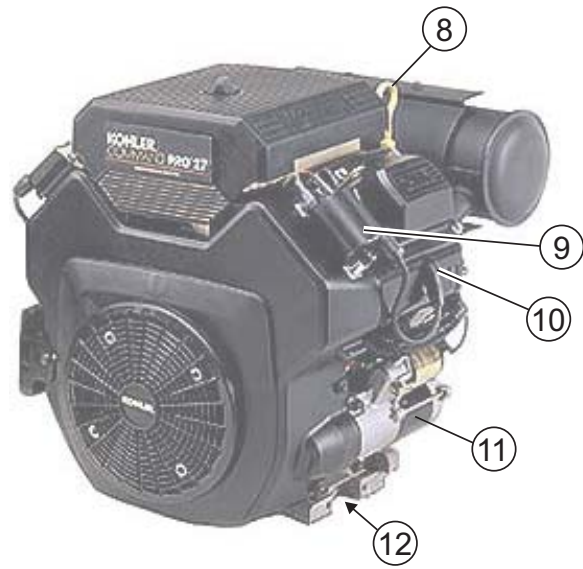

Figure 3. HTN-SERIES Controls and Indicators (Rear)



Kohler 28 HP Engine



Kohler 27 HP Engine

Figure 4. Engine Controls and Components

INITIAL SERVICING

The engine must be checked for proper lubrication and the fuel tank filled with fuel prior to operation. Refer to the manufacturer's engine manual for instructions & details of operation and servicing. The engines shown above are **Kohler** engines.

1. **Muffler** – Used to reduce noise and emissions.

WARNING

Engine components can generate extreme heat. To prevent burns, **DO NOT** touch these areas while the engine is running or immediately after operating. **NEVER** operate the engine with the muffler removed.



2. **Oil Filler Cap** – Remove to add engine oil.
3. **Air Filter** – Prevents dirt and other debris from entering the fuel system. Unsnap air filter cover to gain access to filter element.
4. **Oil Drain Hose** – Remove plug from end of hose to drain crankcase oil.

5. **Oil Cooler** – Helps keep engine oil cooler for longer engine life.
6. **Oil Filter** – Spin-on type, filters oil for contaminants.
7. **Throttle Lever** – Controlled by accelerator pedal, increases or decreases engine RPM.
8. **Oil Dip Stick** – Remove to check amount and condition of oil in crankcase.
9. **Ignition Coil** – Provides spark to the ignition system.
10. **Spark Plug** – Provides spark to the combustion chamber. See engine owner's manual for plug type and gap settings. Clean spark plug once a week.
11. **Starter** – Starts engine when ignition key is rotated to the "START" position.
12. **Side Oil Drain Plug (one of two)** – Remove to drain crankcase oil.

HTN-SERIES — NEW MACHINE SETUP INSTRUCTIONS

Trowel Pre-Set Up Instructions

The purpose of this section is to assist the user in setting up a **NEW** trowel. If your trowel is already assembled, (seat, handles, knobs and battery), this section can be skipped.

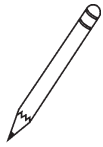
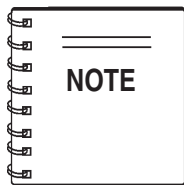

The new trowel cannot be put into service until the pre-setup installation instructions are completed. These pre-setup instructions only need to be performed at the time of unpacking a **NEW** trowel.

Before packaging and shipping, this HTN SERIES Ride-On Power Trowel was run and tested at the factory. If there are problems, please let us know.

Control Handle Assembly

The steering control handles are not attached to the trowel's two lower handles at the time of shipment. To attach the steering control handles to the two lower handle assemblies perform the following:

1. Remove the bolts from the plastic bag tied to the control towers.
2. Remove all protective wrapping and straps from the control handles.
3. Slip the top (loose) piece into the base of the corresponding handle, making sure to line up the holes.
4. Install the bolt through the lined up holes and tighten the acorn nut onto the threaded end.

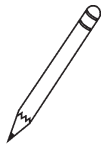
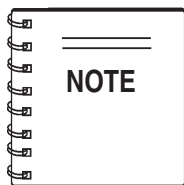

Some models are equipped with adjustable height handles. Adjust the height by placing the bolt through the set of holes that corresponds to the most comfortable height.

5. Pay close attention to any wires that may be inside the control handles. **DO NOT** pinch or cut any wires during installation.
6. Inside the plastic bag of parts are two knobs for the pitch control tower cranks. Install these two knobs onto the tower crank levers.

Seat Assembly

The seat is not installed on the trowel for shipping purposes. To attach the seat perform the following:

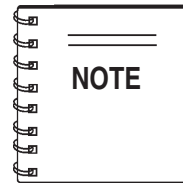

There are two types of seats, depending on what type of trowel you have. J and B series trowels have slots on the seat mounting plate that allow **fore** and **aft** adjustment of the seat. H-series trowels have a seat that is mounted on tracks, similar to an automobile seat. This seat can be adjusted **fore** and **aft** via the control lever under the front of the seat.

1. Remove the seat from the protective wrapping.
2. Remove the bolts on the bottom of the seat, and place seat on the seat mounting plate, then insert the bolts through the holes or slots on the seat mounting plate and tighten.

Battery Setup

This trowel was shipped with a wet charged battery. This battery may need to be charged for a brief period of time as per the manufacturer instructions.

CAUTION

Use all safety precautions specified by the battery manufacturer when working with the battery. See further specific safety information on page 12 of this manual.

To install the battery on the trowel, make sure that the battery is well seated in the battery box. Connect the positive cable to the positive terminal on the battery first, then connect the negative cable to the negative terminal. Close the plastic battery box cover and secure the battery box.

HTN-SERIES — INITIAL START-UP

The following section is intended as a basic guide to the ride-on trowel operation, and is not to be considered a complete guide to concrete finishing. It is strongly suggested that all operators (experienced and novice) read "*Slabs on Grade*" published by the American Concrete Institute, Detroit Michigan.

DO NOT use your ride-on power trowel until this section is thoroughly understood.

CAUTION

Failure to understand the operation of the HTN-SERIES trowel could result in severe damage to the machine or personal injury.

See Figures 2 and 3 (Pages 18 and 19) for the location of any control or indicator referenced in this manual.

Table 3. Recommended Viscosity Grades

		10W-30, 10W-40							
		5W-20, 5W-30							
°F	-20	0	20	32	40	60	80	100	
°C	-30	-20	-10	0	10	20	30	40	
TEMPERATURE RANGE EXPECTED BEFORE NEXT OIL CHANGE									

Engine Oil Level

ALWAYS check engine oil **BEFORE EACH USE**.

1. Pull the engine oil dipstick (Item 8, Page 20) from its holder.
2. Determine if engine oil is low (Figure 5).
3. If engine oil is low, remove oil filler cap (Item 2, Page 20), and add correct amount of engine oil to bring oil level to a normal safe level. The oil level should be up to, but not over the "F" mark on the dipstick. Use oil as recommended in Table 4.

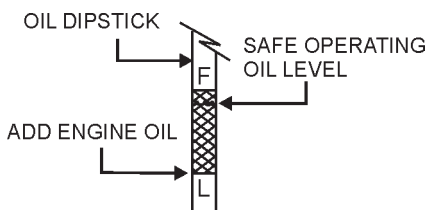
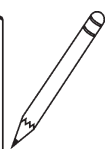
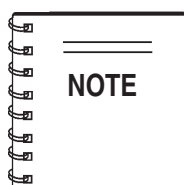

Figure 5. Engine Oil Dipstick



To prevent extensive engine wear or damage, always maintain the proper oil level in the crankcase. Never operate the engine with the oil level below the "L" mark or over the "F" mark on the dipstick.

Gearbox Oil Level



1. Check the gearbox oil level in both gearboxes by removing the level plug and ensuring that the oil is at the correct level. See Figure 6.
2. Fill the gear box just to the level of the fill plug. (Figure 6) with 69 oz. (2.041 L) of Multiquip gearbox lubricant, p/n 20111, ISO or equivalent.

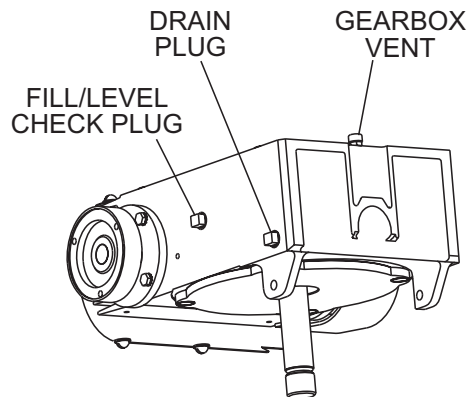

Figure 6. Gearbox Oil Plugs/Sight Glass

Fuel

Determine if the engine fuel is low (Figure 7). If fuel level is low, remove the fuel filler cap and fill with unleaded gasoline.

DANGER

Handle fuel safely. Motor fuels are highly flammable and can be dangerous if mishandled. **DO NOT** smoke while refueling. **DO NOT** attempt to refuel the ride-on trowel if the engine is hot or running. **DO NOT** attempt to start the engine until the fuel residue has been completely wiped up and the area surrounding the engine is dry.

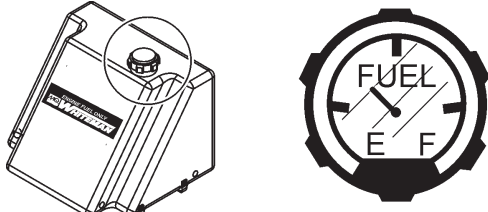

Figure 7. Fuel Gauge

Important Information Before You Start

1. This *ride-on trowel* is equipped with a safety "**safety stop switch**". This switch is located beneath the seat assembly. Remember the engine will not start unless an operator is sitting in the operator's seat. The weight of an operator depresses an electrical switch which will allow the engine to start.

! WARNING

NEVER disable or disconnect the "safety stop switch". It is provided for the **operator's safety** and injury or death may result if it is disabled, disconnected or improperly maintained.

2. The safety stop switch should be used to stop the engine after every use. Doing this will verify the switch is working properly thus providing safety for the operator. Remember to turn the key to the "**OFF**" position after stopping the machine. Not doing so will drain the battery.
3. The right foot pedal (Figure 8) controls blade and engine speed. The position of the foot pedal determines the blade speed. Slow blade speed is obtained by slightly depressing the pedal. Maximum blade speed is obtained by fully depressing the pedal.

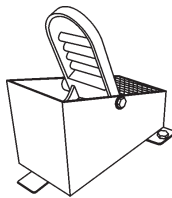

Figure 8. Blade Speed Control Foot Pedal

Starting the Engine

1. With one foot on the ground and the other foot placed on the trowel's platform, grab the frame near the seat and lift yourself onto the trowel. Sit in the operator's seat and ensure the control handles, foot pedal and control panel items can be comfortably accessed.

5. When starting a cold engine, pull the choke knob, if so equipped, (Figure 9) out to the **closed** position. In warm weather or when the engine is warm, the unit can be started with choke halfway or completely **open**. (27 HP engine)

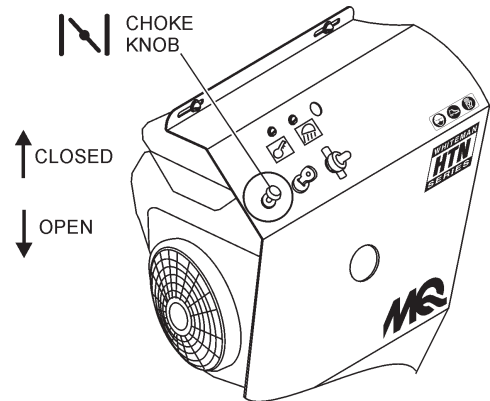

Figure 9. Choke Knob (Kohler 27 HP only)

6. Keep your foot **OFF** the blade speed control pedal and in all circumstances, start the engine at idle (without touching the pedal).
7. Insert the **ignition key** into the ignition switch.
8. Turn the ignition key (Figure 10) clockwise and listen for the engine to start. Once the engine starts release ignition key.
9. If the engine fails to start in this manner, consult the engine owner's manual supplied with the trowel.
10. Test the safety stop switch by standing up briefly. The switch under the seat should cause the engine to stop. If the switch fails to shut down the engine. Turn off the engine with the key switch and repair the safety stop switch. See Table 7 (Troubleshooting) for possible causes.

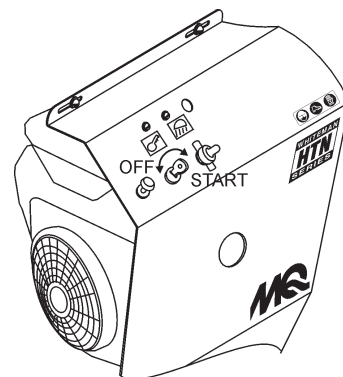
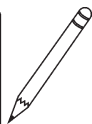
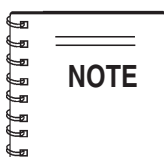

Figure 10. Ignition Key

11. Let the engine idle for 3-5 minutes. If choke is applied, push the choke to the open position as soon as the engine will run smoothly.

Steering

Two control levers located in front of the operator's seat provide directional control for the HTN Series Ride-On Power Trowel. Table 5 (Page 24) illustrates the various directional positions of the joysticks and their effect on the ride-on trowel.



All directional references with respect to the steering control levers are from the **operator's** seat position.

1. Push both the left and right control levers forward. See Figure 11.

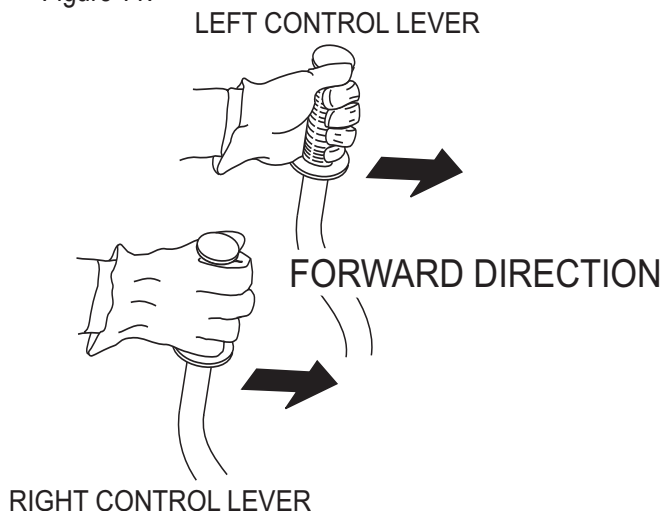

Figure 11. Left and Right Control Levers

2. With your right foot quickly depress the right foot pedal halfway. Notice that the ride-on power trowel begins to move in a forward direction. Return both joystick controls to their neutral position to stop forward movement, then remove your right foot from the right foot pedal.
3. Practice holding the machine in one place as you increase blade speed. When about 75% of maximum blade speed has been reached, the blades will be moving at proper finishing speed. The machine may be difficult to keep in one place. Trying to keep the ride-on trowel stationary is a good practice for operation.
4. Practice maneuvering the ride-on trowel using the information listed in Table 5. Try to practice controlled motions as if you were finishing a slab of concrete. Practice edging and covering a large area.

5. Try adjusting the pitch of the blades. This can be done with the ride-on trowel stopped or while the trowel is moving, whatever feels comfortable. Test the operation of optional equipment like retardant spray and lights if equipped.
6. Pull both the left and right joysticks backward and repeat steps 3 through 6 while substituting the word reverse for forward.

Table 4. Control Lever Directional Positioning

CONTROL LEVER & DIRECTION	RESULT
Move LEFT Control Lever FORWARD ↑	Causes only the left side of the ride-on trowel to move forward.
Move LEFT Control Lever BACKWARD ↓	Causes only the left side of the ride-on trowel to move backward.
Move RIGHT Control Lever FORWARD ↑	Causes only the right side of the ride-on trowel to move forward.
Move RIGHT Control Lever BACKWARD ↓	Causes only the right side of the ride-on trowel to move backward.
Move BOTH Control Levers FORWARD ↑ ↑	Causes the ride-on trowel to move forward in a straight line.
Move BOTH Control Levers BACKWARD ↓ ↓	Causes the ride-on trowel to move backward in a straight line.
Move BOTH Control Levers to the RIGHT → →	Causes the ride-on trowel to move to the right.
Move BOTH Control Levers to the LEFT ← ←	Causes the ride-on trowel to move to the left.

CAUTION

Trowel arms can be damaged by rough handling or by striking exposed plumbing or forms while in operation. **ALWAYS** look-out for objects which might cause damage to the trowel arms.

Maintenance

When performing any maintenance on the trowel or engine, follow all safety messages and rules for safe operation stated at the beginning of this manual.

WARNING

Accidental starts can cause severe injury or death.

ALWAYS place the ON/OFF switch in the OFF position.

Disconnect and ground spark plug leads and disconnect negative battery cable from battery before servicing.

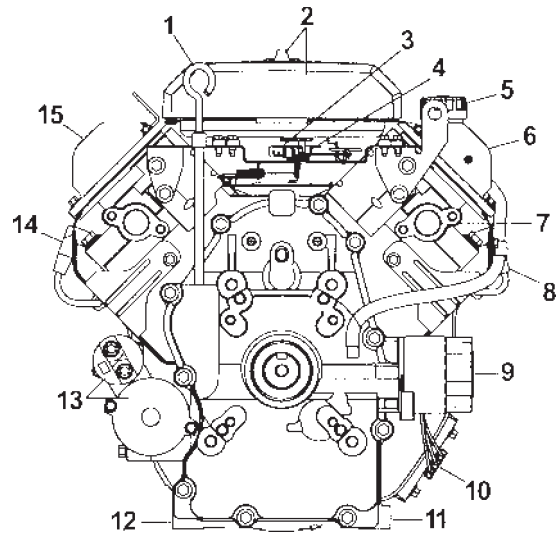

Figure 12. Engine Service Areas

MAINTENANCE SCHEDULE

1. Check and retighten all fasteners as necessary.

Daily (8-10 Hours)

1. Check the fluid levels in the engine and gearboxes, fill as necessary.

Weekly (30-40 Hours)

1. Relube arms, thrust collar and steering links.
2. Replace blades if necessary.
3. Check and clean or replace the engine air filter as necessary. (See following section on Air Filter Maintenance.)
4. Replace engine oil and filter as necessary. (See following section on Oil and Filter.)

Monthly (100-125 Hours)

1. Remove, clean, reinstall and relube the arms and thrust collar. Adjust the blade arms.
2. Replace gearbox lubricant after the first 100 hours of operation. Replace every 500-600 hours thereafter.
3. Check drive belt for excessive wear. (Refer to following section on Drive Belt maintenance.)

Yearly (500-600 Hours)

1. Check and replace if necessary the arm bushings, and thrust collar bushings, shaft seals and belts.
2. Check pitch control cables for wear.
3. Replace gearbox lubricant.

1. Oil Level Dipstick
2. Air Cleaner Cover
3. Carburetor
4. Governor
5. Oil Fill Cap (On either side)
6. #2 Valve Cover
7. #2 Exhaust Port
8. Spark Plug, #2 side
9. Oil Filter
10. Rectifier-regulator
11. Oil Drain (oil filter side)
12. Oil Drain Hose (starter side)
13. Starting Motor and Solenoid
14. Spark Plug, #1 side
15. #1 Valve Cover

Air Cleaner (Daily)

The Kohler 27 hp and 28 hp EFI engines are equipped with a replaceable, high-density paper air cleaner element. Most are also equipped with an oiled-foam precleaner which surrounds the paper element.

Check the air cleaner daily or before starting the engine. Check for and correct heavy buildup of dirt and debris along with loose or damaged components.

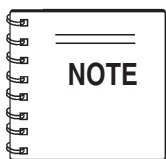

Operating the engine with loose or damaged air cleaner components could allow unfiltered air into the engine causing premature wear and failure.

Precleaner Service

If so equipped, wash and re-oil the precleaner every 25 hours of operation (more often under extremely dusty or dirty conditions).

To service the precleaner perform the following steps, refer to Figure 13:

1. Release the latches located on either side of the air cleaner cover (Figure 13), and remove the cover.
2. Remove the foam precleaner from the paper air cleaner element.
3. Wash the precleaner in warm water with detergent. Rinse the precleaner thoroughly until all traces of detergent are eliminated. Squeeze out excess water (do not wring). Allow the precleaner to air dry.
4. Saturate the precleaner with new engine oil. Squeeze out all excess oil.
5. Reinstall the precleaner over the paper air cleaner element.
6. Reinstall the air cleaner cover and secure the latches.

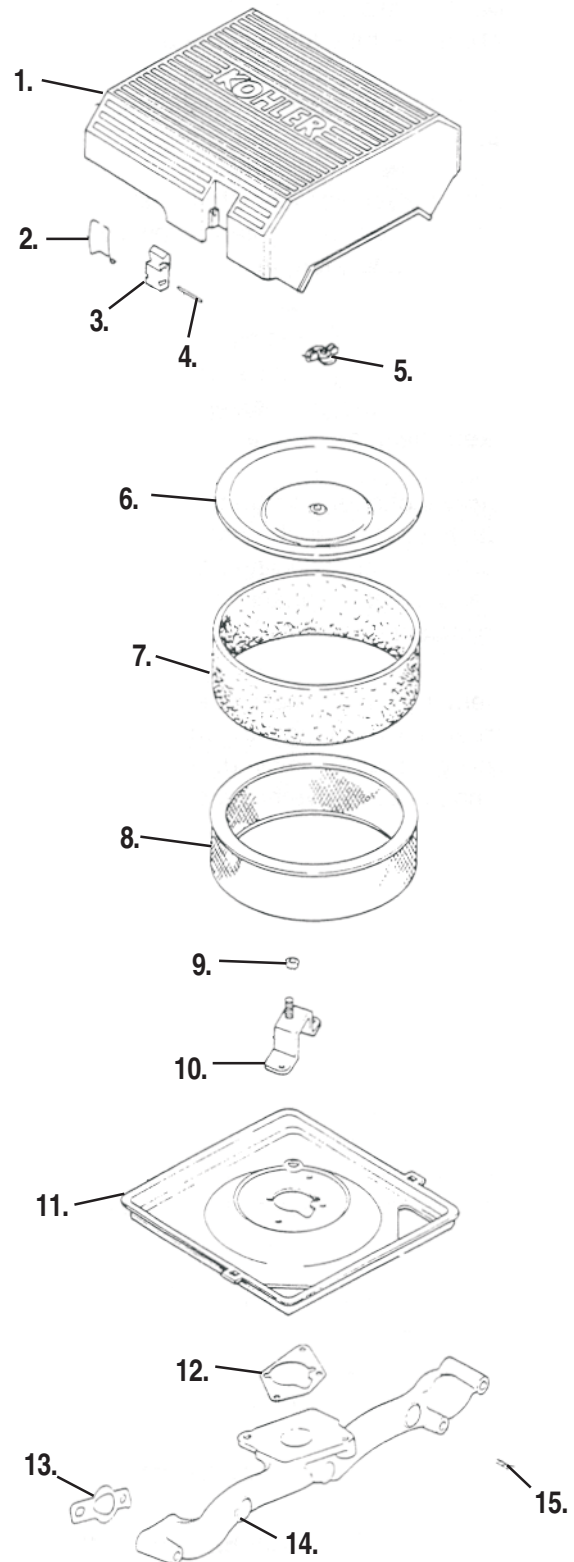

Figure 13. Air Cleaner Components

Air Cleaner Components - See Figure 13.

1. **Air Cleaner Cover**
2. **Latch Spring**
3. **Lever Latch**
4. **Latch Lever Pin**
5. **Wing Nut**
6. **Inner Air Cleaner Cover**
7. **Precleaner Element**
8. **Air Cleaner Element**
9. **seal**
10. **Air Cleaner Bracket**
11. **Air Cleaner Base**
12. **Air Cleaner Base Gasket**
13. **Intake Manifold Gasket**
14. **Intake Manifold**
15. **screw**

Paper Element Service (Standard Type)

Check the paper element every 100 hours of operation (more often under extremely dusty or dirty conditions). Replace the element as necessary.

Refer to the following steps and to Figure 13:

1. Release the latches located on either side of the air cleaner cover (Figure 13), and remove the cover.
2. Remove the wing nut, element cover, seal and air cleaner element.
3. Remove the precleaner (if so equipped) from the paper element.
4. Do not wash the paper element or use pressurized air, as this will damage the element. Replace a dirty, bent, or damaged element with a new element as prescribed by the engine manufacturer. Handle new elements carefully; do not use if the sealing surfaces are bent or damaged.
5. Reinstall the seal, paper element, precleaner, element cover, flat washer and wing nut.
6. Reinstall the air cleaner cover and secure the latches.

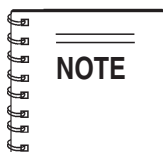

Make sure the correct depth air cleaner element and rubber seal are used for the engine spec. involved.

Air Cleaner - Components to Check

Whenever the air cleaner cover is removed, or the paper element or precleaner is serviced, check the following:

- **Air Cleaner Element Cover and Seal** - Make sure the element cover is not bent or damaged. Make sure the wing nut, washer and seal are in place to ensure the element is sealed against leakage.
- **Air Cleaner Base** - Make sure the base is secured tightly to carburetor and not cracked or damaged.
- **Breather Tube** - Make sure the tube is installed to both the air cleaner base and the breather cover.

Disassembly and Reassembly (Standard Type)

If the base plate on the standard type must be removed, proceed as follows:

1. Remove the air cleaner components as described previously.
2. Remove the hex flange screws securing the bracket and base.
3. Remove the base and gasket. Carefully pull the rubber breather tube through the base
4. Remove the tube from under side of base if necessary.
5. Reverse the foregoing steps to reinstall new or service components. Tighten screw to 9.9 N-m (88 in. lb.) torque.

Air Intake/Cooling System

To ensure proper cooling, make sure the grass screen and fan cooling fins and other external surfaces of the engine are kept clean at all times.

Every 100 hours of operation (more often under extremely dusty or dirty conditions):

1. Remove the blower housing and other cooling shrouds.
2. Clean the cooling fins and external surfaces as necessary.
3. Make sure the cooling shrouds are reinstalled.

CAUTION

Operating the engine with a blocked grass screen, dirty or plugged cooling fins, and/or cooling shrouds removed, will cause engine damage due to overheating.

Changing Engine Oil And Filter

1. Change the engine oil after the first 5 hours of use, then change every 6 months or 100 hours.
2. Remove the oil filler cap (Figure 12, Item 5), and fill engine crankcase with recommended type oil as listed in Table 4. Fill to the upper limit of dipstick.
3. Crankcase oil capacity with oil filter replacement is 2.02 qts. (1.90 liters).

Oil Filter (100 Hours)

1. Replace the engine oil filter (Figure 14) every oil change or 100 hours.

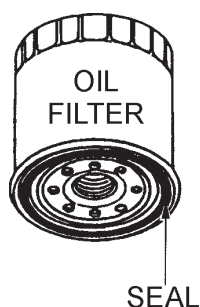

Figure 14. Oil Filter

2. Be sure to coat the **seal** of the new oil filter with clean engine oil.

Fuel Filter (200 Hours)

- Replace the engine fuel filter (Figure 15) every 200 hours.

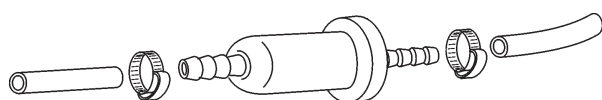

Figure 15. Fuel Filter (Typical)

Oil And Fuel Lines

- Check the oil and fuel lines and connections regularly for leaks or damage. Repair or replace as necessary.
- Replace the oil and fuel lines every two years to maintain the line's performance and flexibility.

Long Term Storage

- Remove the battery.
- Drain fuel from fuel tank, fuel line and carburetor.
- Remove spark plug and pour a few drops of motor oil into cylinder. Crank engine 3 to 4 times so that oil reaches all internal parts.
- Clean exterior with a cloth soaked in clean oil.
- Store unit covered with plastic sheet in moisture and dust-free location out of direct sunlight.

! CAUTION

Never store the ride-on trowel with fuel in the tank for any extended period of time. Always clean up spilled fuel immediately.

Engine Tune-Up

- See your engine manual for specific information on tuning up your engine, checking and gapping the spark plugs, etc.

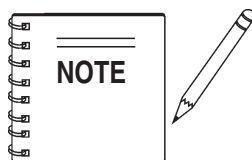

See the engine manual supplied with your machine for appropriate engine maintenance schedule and troubleshooting guide for problems.

At the front of the book (Page 6) there is a "Daily Pre-Operation Checklist". Make copies of this checklist and use it on a daily basis.

Disconnect spark plug wires and battery cables before attempting any service or maintenance on the ride-on trowel.

Checking The Drive Belt

The drive belt needs to be replaced as soon as it starts to show signs of wear. Indications of excessive belt wear are fraying, squealing when in use, belts that emit smoke or a burning rubber smell when in use.

Under normal operating conditions, a drive belt may last approximately 150 hours. If your trowel is not reaching this kind of life span for drive belt wear, check the drive belt for proper pulley alignment and spacing.

To gain access to the drive belt, remove the drive belt guard cover (item 1 Figure 17), then visually inspect the drive belt for signs of damage or excessive wear. If the drive belt is worn or damaged, replace the drive belt.

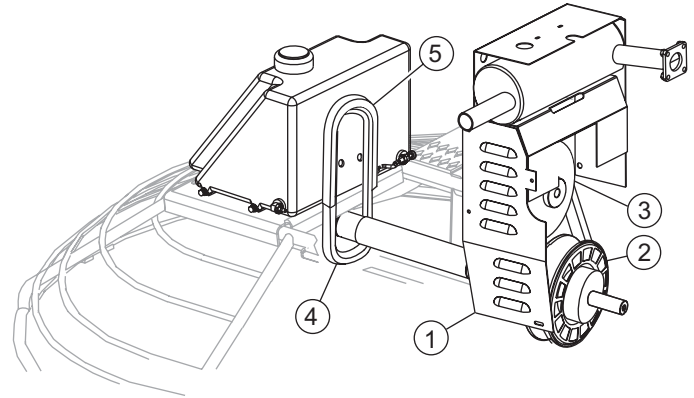

- 1 Drive Belt Guard Cover
- 2 Lower Pulley
- 3 Upper Pulley
- 4 Spare Drive Belt
- 5 Spare Drive Belt Holder

Figure 17. Drive Belt Guard Cover

⚠ WARNING

DO NOT attempt to insert hands or tools into the belt area while the engine is running. **NEVER** run the engine with the safety guards removed. Keep fingers, hands, hair and clothing away from all moving parts to prevent bodily injury.



⚠ WARNING

DO NOT remove the drive belt guard cover until the muffler has cooled. Allow the entire trowel to cool down before performing this procedure.



1. Remove Drive Belt Guard Cover (item 1 Figure 17).
2. Squeeze the drive belt as shown in Figure 18, and pull the V-belt upwards. This will spread open the faces of the **lower** drive pulley.

Removing the Drive Belt

- Leave the existing drive belt intact until instructed to cut it.
- Leave the engine in place for this procedure. It is not necessary to slide the engine to replace the drive belt.
- Have a 3/4 X 1 X 3-1/4 inch wooden block available.

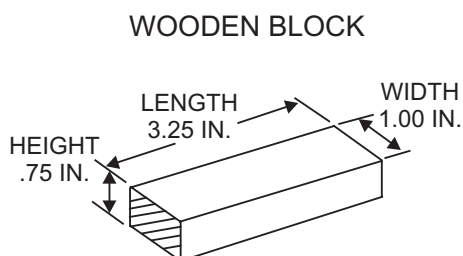
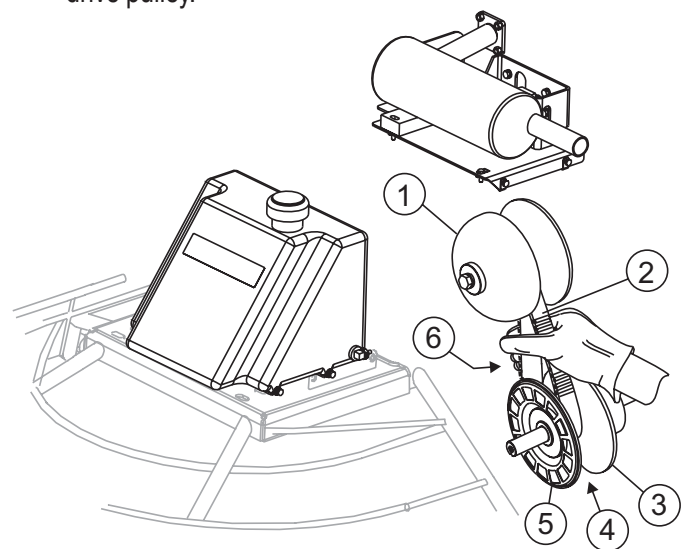

Figure 16. Wooden Block For Spacer



- 1 Upper Pulley
- 2 Drive Belt
- 3 Lower Pulley Fixed Face
- 4 Lower Pulley Spread Apart
- 5 Lower Pulley Movable Face
- 6 Squeeze and Pull Up To Spread Lower Pulley

Figure 18. Expanding Lower Drive Pulley

3. **Insert** the 3/4" X 1" X 3-1/4" block between the moveable face and the fixed face of the lower drive pulley. See Figure 19. This block will help keep the lower drive pulley faces open while installing the new drive belt.

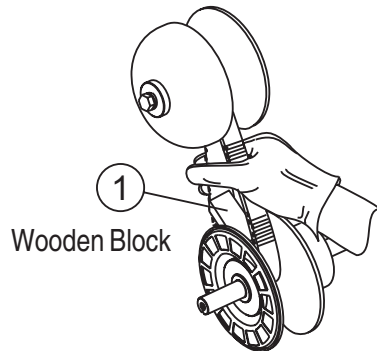

Figure 19. Holding Lower Pulley Open

4. If the belt is not being reused (recommended), **CUT** the drive belt. Ensure all belt remnants are removed from the pulleys.

Installing the Drive Belt (Using Replacement Drive Belt)

The HTN-SERIES Ride-On Power Trowel is equipped with a replacement drive belt (spare) carrier, which is mounted on the inboard side of the fuel tank near the clutch. Make sure that there is **ALWAYS** a spare drive belt in the drive belt carrier before the trowel is placed on a slab to finish concrete.

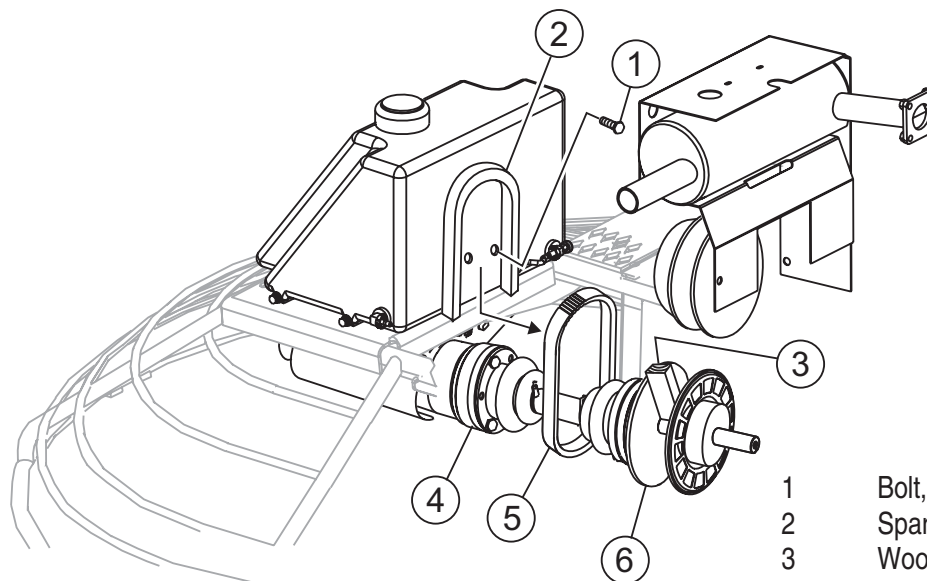
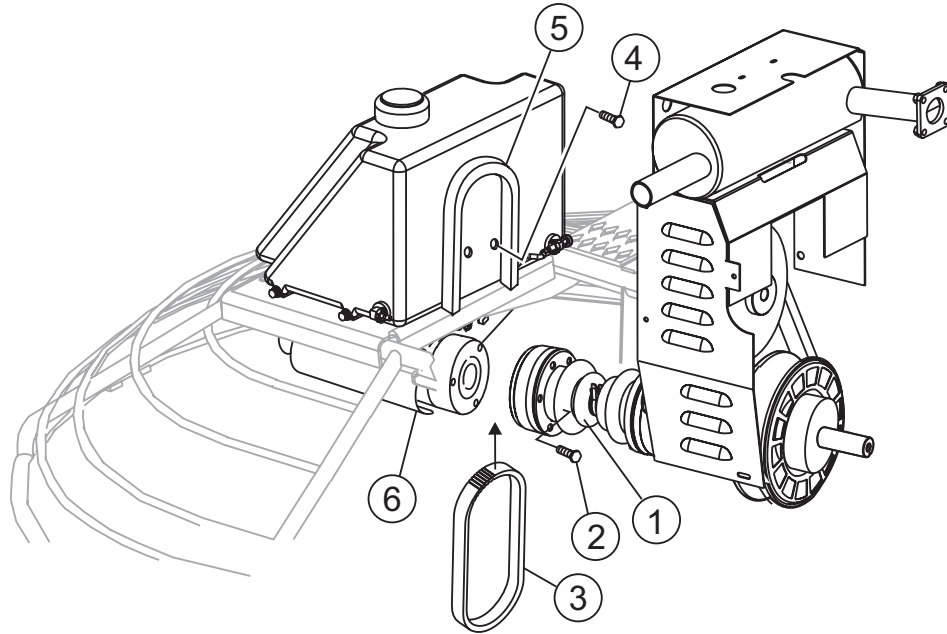

Figure 20. Drive Belt Install

- 1 Bolt, Spare Drive Belt Carrier
- 2 Spare Drive Belt Holder
- 3 Wooden Block
- 4 CV-Joint
- 5 New Spare Drive Belt
- 6 Lower Drive Pulley

In the event of a drive belt failure, the spare (replacement) drive belt can be used for quick replacement at the job site to continue trowel operation.

1. If necessary, refer to Removing Drive Belt Instructions. Ensure all remnants of old belt have been removed from pulleys.
2. To replace the drive belt with the spare drive belt, remove the 2 bolts that secure the drive belt carrier. (Figure 20) This will allow free movement of the belt for installation. Take care with to not contaminate the replacement belt with grease or dirt.
3. With the 3/4 x 1 x 3-1/4 wood block holding the lower pulley open, place the replacement belt into the lower pulley first. Work the belt over the upper drive pulley into the pulley groove.
4. Squeeze the belt enough to remove the wood block. With the block removed, release the tension on the belt.
5. Reinstall the spare belt carrier and the drive belt guard.
6. Replace the spare belt before the next trowel use. See spare drive belt replacement procedures.



- | | |
|---|--------------------------------|
| 1 | CV Joint |
| 2 | Bolt (Remove 3 places) |
| 3 | New Spare Drive Belt |
| 4 | Bolt, Spare Drive Belt Carrier |
| 5 | Spare Drive Belt Holder |
| 6 | Left Side Gearbox |

Figure 21. Spare Drive Belt Replacement

Spare Drive Belt Replacement



It will be necessary to disconnect the CV-Joint from the left-side gearbox coupler. This means the removal of the three screws that secure the CV-Joint to the gearbox.

To replace a spare drive belt, be prepared to disconnect the CV-joint from the left-side gearbox. See Figure 21.

1. Place the trowel on suitable supports and observe all safety precautions.
2. Remove the three screws that secure the CV-joint to the left-side gearbox coupler.
3. Once the CV-joint has been separated from the left-side gearbox, push the CV-joint inward so that a gap exists between the gearbox and the CV-joint (Figure 21). Slide the spare V-belt between the gearbox coupler and the CV-joint. Avoid contaminating the replacement belt with grease or oil when sliding it between the CV-Joint and gearbox coupler.
4. Place the spare drive belt inside the drive belt carrier, and secure the spare belt carrier to the inboard side of the left gearbox.
5. Install the three screws that secure the CV-joint to the left-side gearbox coupler.

Drive System Theory of Operation

The HTN-SERIES Ride-On Power Trowel is equipped with a "Torque Converter" which supplies torque to both the left and right gearboxes.

The function of the torque converter is to automatically deliver the correct amount of torque required by the trowel under all load conditions. This enables the trowel to deliver the necessary torque for float pan applications and the high rotor speeds required for burnishing concrete.

The torque converter used in the HTN SERIES Ride-On Power Trowel is a variable pitch pulley type (Figure 22) connected by a drive belt.

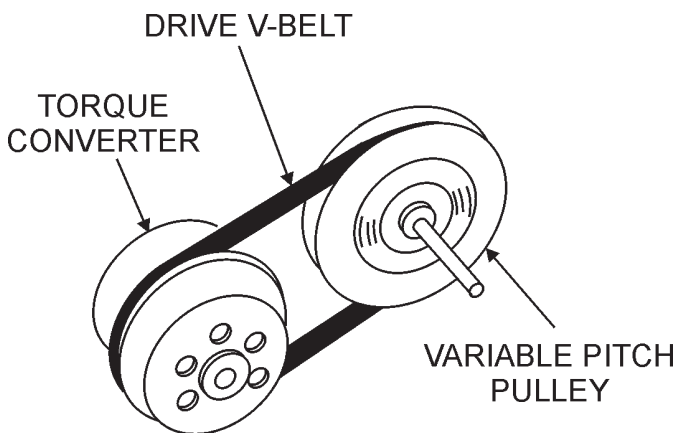

Fig. 22 Torque Converter/Variable Pitch Pulley

Drive Pulley

The "Drive Pulley" uses centrifugal force (Figures 23 and 24) to create a belt squeeze force transmitted at the pulley faces. This condition functions as an automatic clutch and transmission.

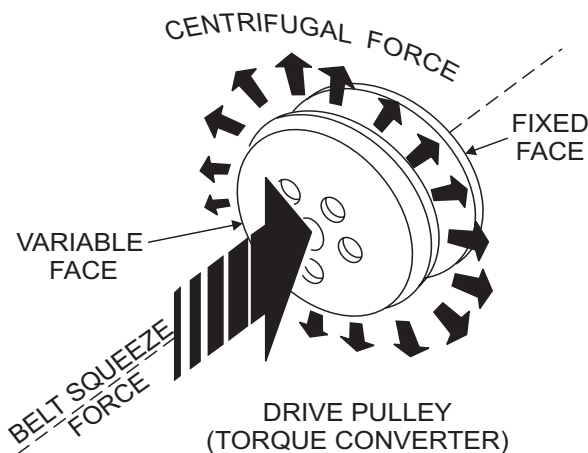

Figure 23. Torque Converter (Centrifugal Force)

Centrifugal force pushes the roller arms against the ramp plate, forcing the moveable face toward fixed face squeezing the belt. (see Figure 24 below)

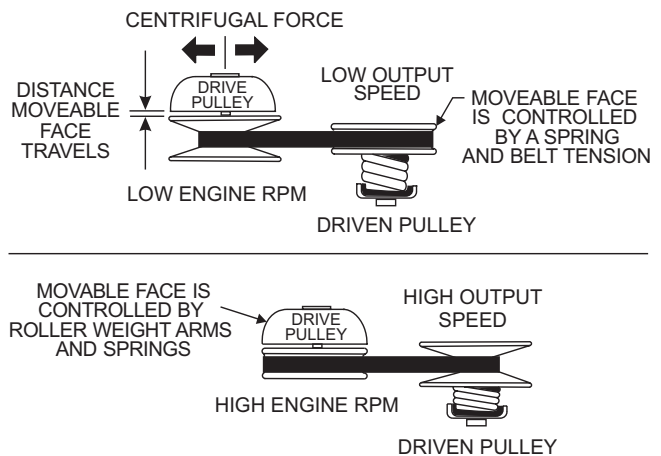

Fig. 24. Pulley Interaction

The "Variable Pitch Pulleys" have one *fixed face*, and one *moveable face*. The *drive pulley* (torque converter, Figure 25) moveable face is controlled by roller weight arms and springs, which change position according to engine speed. The *driven pulley moveable face* is controlled by a spring and belt tension.

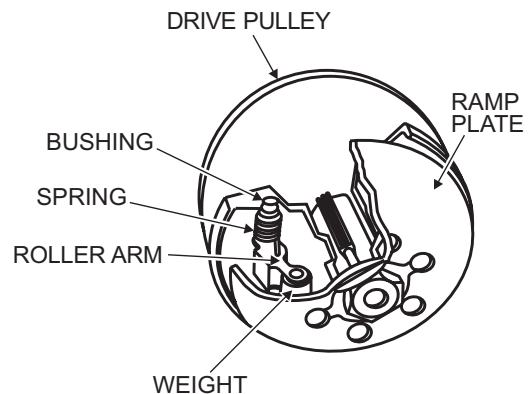

Fig. 25. Variable Pitch Pulley

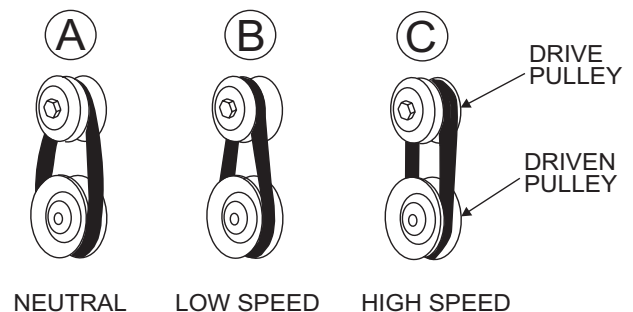

Figure 26. Pulley Conditions

How It Works (Figure 26)

- Condition A:**
- Engine Idling
 - Drive Pulley: Small
 - Driven Pulley: Large
 - Belt: Loose and Stationary
- Condition B:**
- Engine Accelerating
 - Drive Pulley: Small But Increasing
 - Driven Pulley: Large But Decreasing
 - Belt: Approaching Tightness
- Condition C:**
- Engine At High Speed
 - Drive Pulley: Large
 - Driven Pulley: Small
 - Belt: Tight

Clutch

This clutch system provides a high pulley ratio (a low gear- so to speak) to start out and a low pulley ratio (a high gear- so to speak) for a high speed operation, with infinite variation between the two.

This means that it will not be necessary to give **full throttle** in order to "break the blades/pans loose". The machine can slowly be brought up to speed.

The torque-sensitive pulley (Figure 27) utilizes a spring and cam. Peak performance results from proper interaction between the driven pulley spring and the ramp angle of the cam bracket.

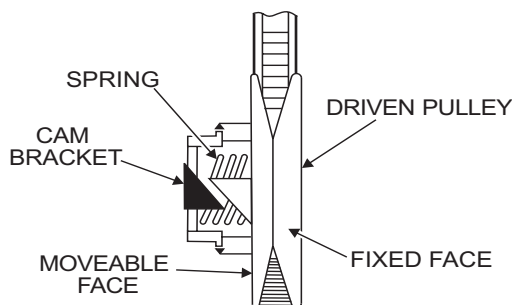

Figure 27. Pulley Spring and Cam Bracket

Blade Pitch

Sometimes it may be necessary to match blade pitch between the two sets of blades. There are some signs that this may be necessary. For example, the differences in pitch could cause a noticeable difference in finish quality between the two sets of blades. Or, the difference in blade pitch could make the machine difficult to control. This is due to the surface area in contact with the concrete (the blade set with the greater contact area tends to stick to the concrete more).

Matching Blade Pitch for Both Sets of Blades

Trowels equipped with **Twin Pitch™** Controls may need to have blade pitch between the two sets of blades "synchronized". If the blades need to be synchronized this is easily accomplished by performing the following. Refer to Figure 28.

1. Lift the pitch adjustment handle on either side. Once lifted, that side is now disconnected from the **Twin Pitch™** system.
2. Adjust to match the opposite side.
3. When adjusted, lower the handle to **Twin Pitch™** operating position.

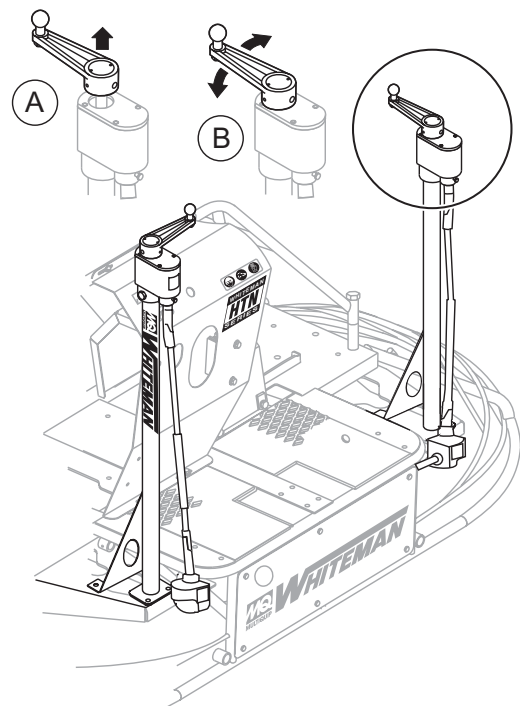

- A **Twin Pitch™** disengaged (one side)
 B Operating Position

Figure 28. Pitch Towers

Trowel Arm adjustment Procedure

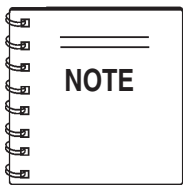

The following procedure should be followed to adjust trowel arms when it becomes apparent that the trowel is finishing poorly or in need of routine maintenance.

A **level**, clean area to test the trowel prior to and after adjustment is essential. Any unlevel **spots** in the floor or debris under the trowel blades will give an incorrect perception of adjustment. Ideally, a 5' x 5' three-quarter inch thick **flat** steel plate should be used for testing.

- To determine which blades need adjustment, place the trowel in the test area (three-quarter inch thick plate) and look for the following conditions:
 - Pitch the blades as flat as possible and look at the **adjustment bolts**. They should all barely make contact with the **lower wear plate** on the spider. If you can see that one of them is not making contact, some adjustment will be necessary.
 - Is the machine wearing out blades unevenly (i.e. one blade is completely worn out while the others look new)?

Figure 29 below illustrates "**worn spider bushings or bent trowel arms**". Check to see that adjustment bolt is barely touching (0.10" max. clearance) lower wear plate. All alignment bolts should be spaced the same distance from the lower wear plate.

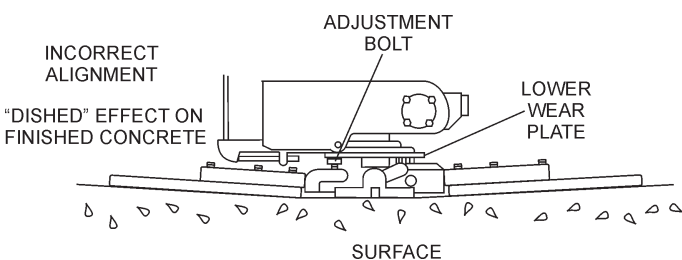

Figure 29. Worn Arm Bushings

Figure 30 below illustrates the "**correct alignment**" for a spider plate (as shipped from the factory).

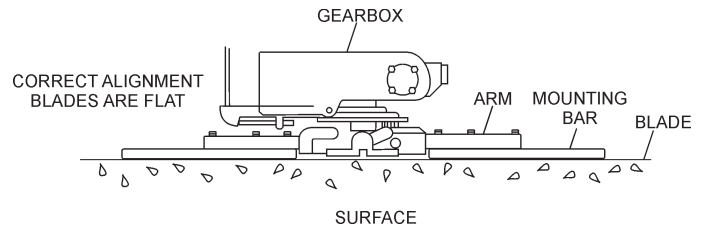

Figure 30. Correct Spider Plate Alignment

- Start engine, and bring trowel blades up to full speed and look for the following conditions:
 - Does the trowel have a perceived rolling or bouncing motion?
 - Does the guard ring "rock up and down" relative to the ground?

Stabilizer Ring Removal

- If the trowel is equipped with an outer stabilizer ring (Figure 31), remove the four bolts at the end of each spider arm.

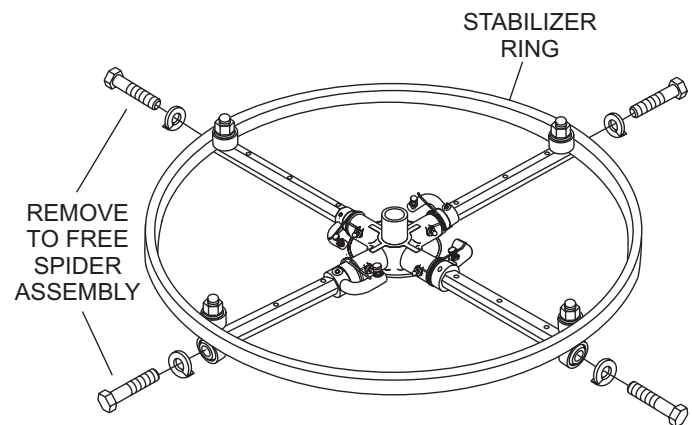
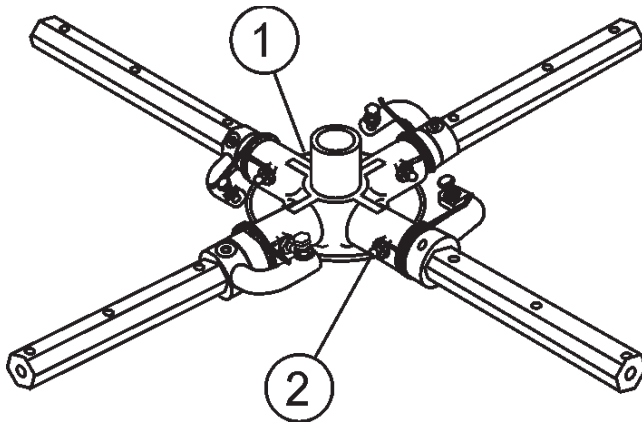

Figure 31 Stabilizer Ring

- Examine stabilizer ring for out of round or bends. If ring is damaged, replace ring. If ring is found to be correct with no damage, set aside.

Trowel Arm Removal

1. Each trowel arm is held in place at the spider plate by a hex head bolt (with zerk grease fitting). Remove the hex head bolt/zerk grease fitting from the spider plate. (Figure 32)
2. Remove the trowel arm from the spider plate.



- 1 Spider Plate
- 2 Hex Head Bolt (Zerk Fitting)

Figure 32. Removing Zerk Grease Fitting

3. Should the trowel arm inserts (bronze bushing) come out with the trowel arm, remove the bushing from the trowel arm and set aside in a safe place. If the bushing is retained inside the spider plate, carefully remove the bushing.
4. Examine the bronze trowel arm bushing insert (Figure 33), clean if necessary. Replace bushing if out-of-round or worn.

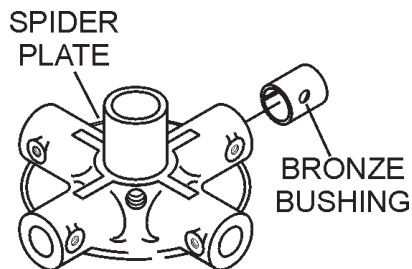

Figure 33. Bronze Bushings

Trowel Blade Removal

1. Remove the trowel blades from the trowel arm by removing the three hex head bolts (Figure 34) from the trowel arm. Set blades aside.

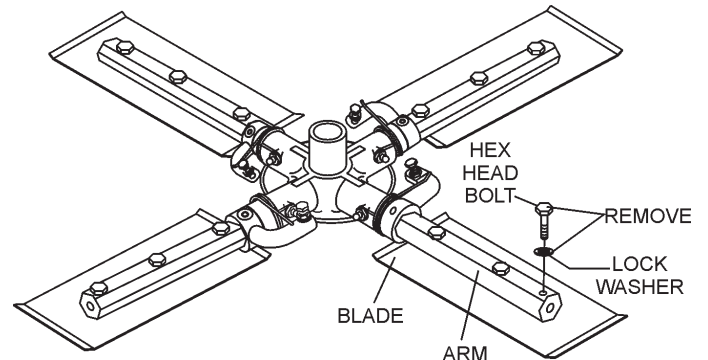
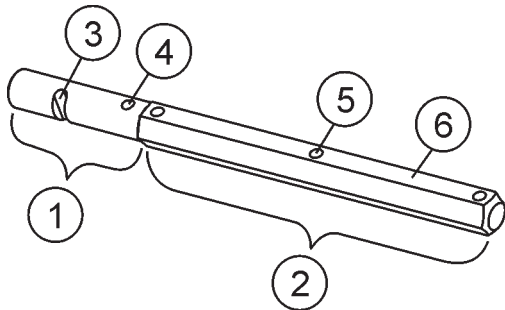

Figure 34. Trowel Blades

2. **Wire brush** any build-up of concrete from all six sides of the trowel arm. Repeat this for the remaining three arms.

Checking Trowel Arm Straightness

Trowel arms can be damaged by rough handling, (such as dropping the trowel on the pad), or by striking exposed plumbing, forms, or rebar while in operation. A bent trowel arm will not allow the trowel to operate in a smooth fluid rotation. If bent trowel arms are suspect, check for flatness as follows, refer to Figures 35 and 36:



- 1 Trowel Arm Round Shaft Section
- 2 Trowel Arm Hexagonal (Hex) Shaft Section
- 3 Lever Mounting Slot (Left Arm Shown)
- 4 Roll Pin Hole
- 5 Blade Attachment Bolt Hole (One of Three)
- 6 Flat of Hexagonal Shaft (Top of Arm)

Figure 35. Trowel Arm

1. Use a thick steel plate, granite slab or any surface which is **true** and **flat**, to check all **six sides** of each trowel arm for flatness.
2. Check each of the six sides of the trowel arm (hex section). A feeler gauge of .004" (0.10 mm) should not pass between the flat of the trowel arm and the test surface along its length on the test surface. (Figure 36 item 3).

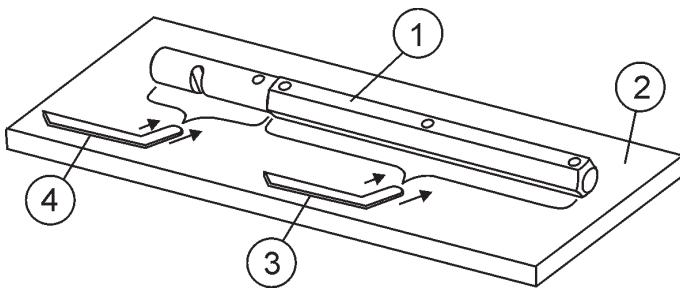

- 1 Trowel Arm
- 2 Flat Test Surface
- 3 Feeler Gauge (.004 in. / 0.10 mm)
- 4 Feeler Gauge (.005 in. / 0.127 mm)

Figure 36. Checking Trowel Arm Flatness

3. Next, check the clearance between the round shaft and the test surface as one of the flat hex sections of the arm rests on the test surface. Rotate the arm to each of the flat hex sections and check the clearance of the round shaft. Use a feeler gauge of .005" (0.127 mm). Each section should have the **same clearance** between the round of the trowel arm shaft and the test surface.
4. If the trowel arm is found to be **uneven** or **bent**, replace the trowel arm.

Trowel Arm Adjustment

Shown in (Figure 39) is the adjustment fixture with a trowel arm inserted. As each trowel arm is locked into the fixture, the arm bolt is adjusted to where it contacts a stop on the fixture. This will consistently adjust all of the trowel arms, keeping the finisher as flat and evenly pitched as possible.

1. Locate the trowel arm adjustment tool P/N 9177.

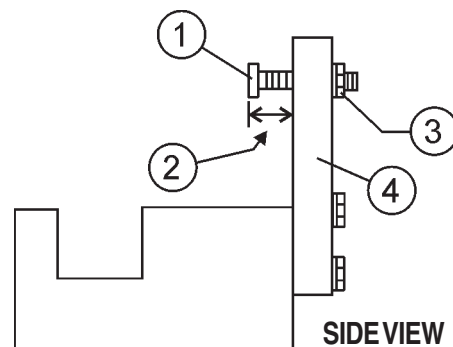

- 1 Adjustment Bolt
- 2 "Distance"
- 3 Locking Nut
- 4 Fixture Arm

Figure 37. Trowel Arm Adjustment Tool Side View

2. Ensure the fixture arm is in the proper setting (up or down) for your trowel arm rotation as shown in Figure 38.

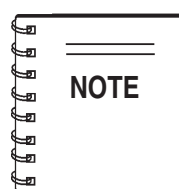

Arms with **CLOCK-WISE** blade rotation use the fixture arm in the **UP** position (A in Figure 38). Arms with **COUNTER CLOCK-WISE** blade rotation use the fixture with the fixture arm in the **DOWN** position. (B in Figure 38).

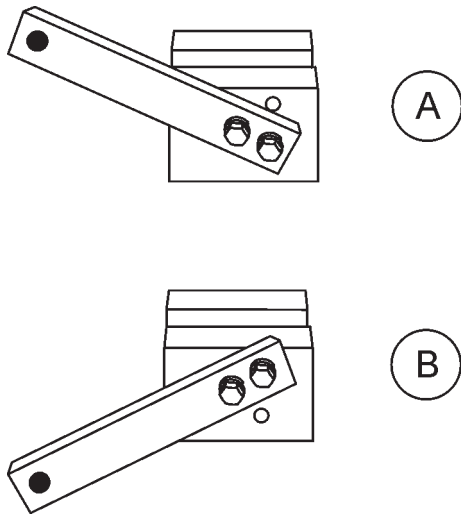
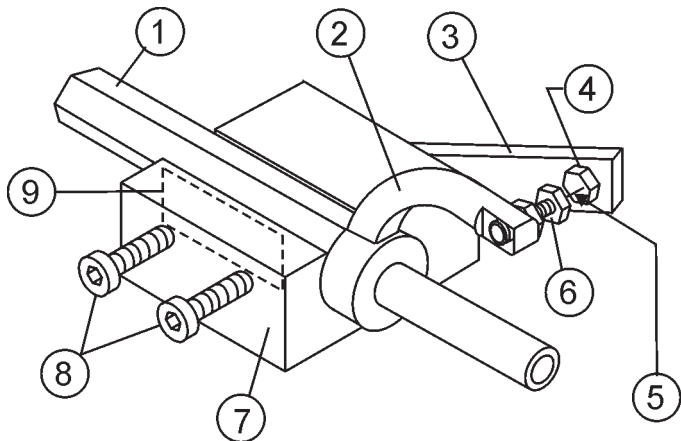

Figure 38. Trowel Arm Adjustment Setup

3. Unscrew the locking bolts on the adjustment tool and place the trowel arm into the fixture channel as shown in Figure 39. A **thin shim** may be required to cover the blade holes on the trowel arm. Make sure to align the **trowel** adjustment bolt with the **fixture** adjustment bolt.



- | | |
|---|-------------------------------|
| 1 | Arm |
| 2 | Trowel Arm Lever |
| 3 | Fixture Arm |
| 4 | Adjustment Bolt |
| 5 | Distance = .010 Inch |
| 6 | Adjustment Bolt |
| 7 | Trowel Arm Adjustment Fixture |
| 8 | Locking Bolts |
| 9 | Shim |

Figure 39. Trowel Arm Adjustment Fixture Components

4. Use an allen wrench to tighten the locking bolts securing the trowel arm in place.
5. Adjust the bolt "distance" shown in Figure 37 to match one of the arms. The other arms will be adjusted to match this distance.
6. Loosen the locking nut on the trowel arm lever, then turn the trowel arm adjusting bolt until it barely touches (.010") the fixture adjusting bolt.
7. Once the correct adjustment is made, tighten the lock nut on the trowel arm to lock in place.
8. Loosen locking nuts on the adjustment fixture, and remove trowel arm.
9. Repeat steps for the remaining trowel arms.

Re-Assembly

1. Clean and examine the upper/lower wear plates and thrust collar. Examine the entire spider assembly. Wire brush any concrete or rust build-up. If any of the spider components are found to be damaged or out of round, replace them.
2. Make sure that the bronze trowel arm bushing is not damage or out of round. Clean the bushing if necessary. If the bronze bushing is damaged or worn, replace it.
3. Reinstall bronze bushing onto trowel arm.
4. Repeat steps 2-3 for each trowel arm.
5. Make sure that the spring tensioner is in the correct position to exert tension on the trowel arm.
6. Insert all trowel arms with levers into spider plate (with bronze bushing already installed) using care to align grease hole on bronze bushing with grease hole fitting on spider plate.
7. Lock trowel arms in place by tightening the hex head bolt with zerk grease fitting and jam nut.
8. Re-install the blades onto the trowel arms.
9. Install stabilizer ring onto spider assembly.
10. Lubricate all grease points (zerk fittings) with premium "**Lithum 12**" based grease, conforming to NLG1 Grade #2 consistency.

Installing Pans Onto Finisher Blades

These round discs sometimes referred to as "pans" attach to the spiders arms and allow early floating on wet concrete and easy movement from wet to dry areas. They are also very effective in embedding large aggregates and surface hardeners.



Refer to Figure 40 when installing pans onto finisher blades.

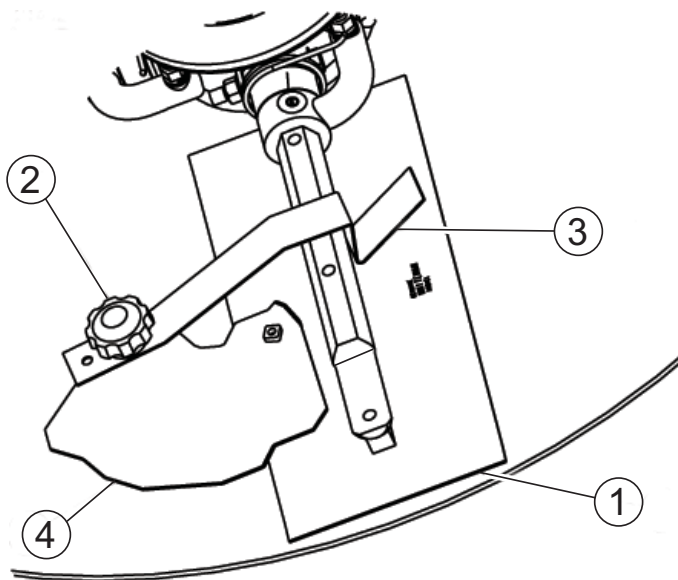

- 1 BLADE ASSEMBLY
- 2 KNOB, TIE-DOWN Z-CLIP PANS
- 3 TIE-DOWN, BLADE
- 4 Z-CLIP, PAN

Figure 40. Z-Clip Finisher Pan Installation

1. Lift trowel just enough to slide pan under blades. Lower finisher onto pan with blades (item #1) adjacent to Z-Clips (item #4).
2. Rotate blades into position under Z-Clips. Ensure that the blades are rotated in the direction of travel when the machine is in operation or use the engine to rotate the blades into position.
3. Attach the blade tie-downs (item #3) to the far side of the Z-Clip brackets (item #4) with tie-down knobs (item #2) as shown in figure 40.
4. Check to make certain that the blade edges are secured under the Z-Clips and the tie-downs are secured completely over the edges of the blade bar before the machine is put back into operation.

Decommissioning Trowel/Components

Decommissioning is a controlled process used to safely retire a piece of equipment that is no longer serviceable. If the equipment poses an unacceptable and unrepairable safety risk due to wear or damage or is no longer cost effective to maintain, (beyond life-cycle reliability) and is to be decommissioned, (demolition and dismantlement), the following procedure must take place:

1. Drain all fluids completely. These may include oil, gasoline, hydraulic oil and antifreeze. Dispose of properly in accordance with local and governmental regulations. Never pour on ground or dump down drains or sewers.
2. Remove battery and bring to appropriate facility for lead reclamation. Use safety precautions when handling batteries that contain sulfuric acid, (See page 12).
3. The remainder can be brought to a salvage yard or metal reclamation facility for further dismantling.

HTN-SERIES — TROUBLESHOOTING (ENGINE)

TABLE 5. ENGINE TROUBLESHOOTING

SYMPTOM	POSSIBLE PROBLEM	SOLUTION
Engine Cranks But Will Not Start	Fuel tank is empty.	Fill fuel tank.
	Shut-off valve is closed.	Open fuel shut-off valve.
	Fuel line has suction leak or is restricted. Fuel filter, or fuel tank cap vent is obstructed.	Check fuel line condition and fuel line clamps. Ensure that fuel line is not kinked. Check fuel filter for restriction and replace if necessary. Check fuel cap vent and clean or replace as necessary.
	Fuel supply is contaminated.	Drain and clean fuel tank, clean tank and refill with fuel.
	If carbureted, carburetor is underchoked or overchoked.	Apply recommended amount of choke for cold and warm weather.
	Spark plug is fouled, improperly gapped, or damaged. Spark plug leads disconnected.	Check spark plug for fouling, check gap, and inspect for damage. Clean or replace spark plug as necessary. Reattach spark plug leads if disconnected.
	Safety stop switch malfunction.	Ensure that the Safety Stop Switch is functioning when the operator is seated; replace switch if necessary.
Engine Starts But Will Not Continue Running	Fuel tank is empty.	Fill fuel tank.
	Shut-off valve is closed.	Open fuel shut-off valve.
	Fuel line has suction leak or is restricted. Fuel filter is obstructed, or fuel tank cap vent is blocked.	Check fuel line condition and fuel line clamps. Ensure that fuel line is not kinked. Check fuel filter for restriction and replace if necessary. Check fuel cap vent and clean or replace as necessary.
	If engine is carbureted, carburetor is underchoked or over choked.	Apply recommended amount of choke for cold and warm weather.
	Faulty ignition switch or starter.	Replace defective switch or starter.
	Engine is seized.	Repair or replace engine.

HTN-SERIES — TROUBLESHOOTING (ENGINE)

TABLE 5 CONT.. ENGINE TROUBLESHOOTING

SYMPTOM	POSSIBLE PROBLEM	SOLUTION
Engine Lacks Power	Air filter is obstructed.	Replace air filter.
	Altitude causes 3% loss of horsepower per 1000 feet of altitude.	If available, install high altitude jets in carburetor.
	Choke is partially closed.	Open choke.
	Faulty spark plugs or spark plug leads. Spark plug lead disconnected.	Replace spark plugs or spark plug leads if faulty. Reattach spark plug lead if disconnected.
	Fuel is contaminated.	Drain and clean fuel tank. Refill with clean fuel.
	There is a lack of lubrication.	Check engine oil.
	Engine is overheated	Allow engine to cool. Find and repair cause of overheating.
	Exhaust is restricted.	Remove or repair restriction.
	Ignition timing incorrect.	Set engine ignition timing to manufacturer's specification.
Engine Overheats	Ignition timing incorrect.	Set engine ignition timing to manufacturer's specification.
	Fuel mixture is too lean.	Look for intake system leak. Repair any leaks found.
	Exhaust is restricted.	Remove or repair restriction.
	Fan shroud or fan is broken or missing.	Replace fan shroud.
	Coolant level is low.	Fill radiator when cool. Add coolant to fill line on reservoir.
	Low or Hi crankcase oil level	Check engine oil. Fill if low, drain if overfilled.
Engine Will Not Crank	Battery is discharged or defective.	Charge and test battery. Replace if defective.
	Loose or faulty wires or connections.	Inspect wiring, repair any bad connections or wires.
	Faulty ignition switch or starter.	Replace defective switch or starter.
	Engine is seized.	Repair or replace engine.

HTN-SERIES—TROUBLESHOOTING (TROWEL)

TABLE 6. TROUBLESHOOTING

SYMPTOM	POSSIBLE PROBLEM	SOLUTION
Engine running rough or not at all.	Safety Stop Switch malfunction?	Make sure that the Safety Stop Switch is functioning when the operator is seated; replace switch if necessary.
	Fuel?	Look at the fuel system. Make sure there is fuel being supplied to the engine. Check to ensure that the fuel filter is not clogged.
	Ignition?	Check to ensure that the ignition switch has power and is functioning correctly.
	Other problems?	Consult engine manufacturer's manual.
Safety Stop Switch not functioning.	Loose wire connections?	Check wiring. Replace as necessary.
	Bad contacts?	Replace switch.
If trowel "bounces, rolls concrete, or makes uneven swirls in concrete".	Blades?	Make certain blades are in good condition, not excessively worn. Finish blades should measure no less than 2" (50mm) from the blade bar to the trailing edge, combo blades should measure no less than 3.5" (89mm). Trailing edge of blade should be straight and parallel to the blade bar.
	Spider?	Check that all blades are set at the same pitch angle as measured at the spider. A field adjustment tool is available for height adjustment of the trowel arms (see Optional Equipment).
	Bent trowel arms?	Check the spider assembly for bent trowel arms. If one of the arms is even slightly bent, replace it immediately.
	Trowel arm bushings?	Check the trowel arm bushings for tightness. This can be done by moving the trowel arms up and down. If there is more than 1/8" (3.2 mm) of travel at the tip of the arm, the bushings should be replaced. All bushings should be replaced at the same time.
	Thrust collar?	Check the flatness of the thrust collar by rotating it on the spider. If it varies by more than 0.02" (0.5 mm) replace the thrust collar.
	Thrust collar bushing?	Check the thrust collar by rocking it on the spider. If it can tilt more than 1/16" (1.6 mm) [as measured at the thrust collar O.D.], replace the bushing in the thrust collar.
	Thrust bearing worn?	Check the thrust bearing to see that it is spinning free. Replace if necessary.
	Blade pitch?	Check blades for consistent pitch. Adjust per Maintenance section instructions if necessary.
Machine has a perceptible rolling motion while running.	Main shaft?	The main output shaft of the gearbox assembly should be checked for straightness. The main shaft must run straight and cannot be more than 0.003" (0.08 mm) out of round at the spider attachment point.
	Yoke?	Check to make sure that both fingers of the yoke press evenly on the wear cap. Replace yoke as necessary.

HTN-SERIES—TROUBLESHOOTING (TROWEL)

TABLE 6. TROUBLESHOOTING (CONTINUED)

SYMPTOM	POSSIBLE PROBLEM	SOLUTION
Lights not working.	Wiring?	Check all electrical connections, including the master on/off switch and check to see if wiring is in good condition with no shorts. Replace as necessary.
	Lights?	Check to see if light bulbs are still good. Replace if broken.
Retardant spray not working.	Retardant?	Check the tank to make sure retardant is present. Fill tank as necessary.
	Wiring?	Check all electrical connections, including master on/off switch connections. Replace components and wiring as necessary.
	Bad switch?	Check the continuity of master on/off switch. Replace if broken.
	Bad spray pump?	If pump has a voltage present when the switch is turned on, but does not operate and electrical connections to the pump are good, replace the pump.
Steering is unresponsive.	Worn components?	Check for wear of steering bearings and linkage components replace if necessary.
	Pivots?	Check to ensure free movement at pivot bushings.
Operating position is uncomfortable.	Seat adjusted for operator?	Adjust seat with lever located on the front of the seat.
Linkage on Twin Pitch not working.	Crank handles?	Make sure that both crank handles are pushed down as far as possible. Doing this ensures that the linkage is engaged.
	Broken part?	Replace all broken parts immediately.

PAYMENT TERMS

Terms of payment for parts are net 30 days.

FREIGHT POLICY

All parts orders will be shipped collect or prepaid with the charges added to the invoice. All shipments are F.O.B. point of origin. Multiquip's responsibility ceases when a signed manifest has been obtained from the carrier, and any claim for shortage or damage must be settled between the consignee and the carrier.

MINIMUM ORDER

The minimum charge for orders from Multiquip is \$15.00 net. Customers will be asked for instructions regarding handling of orders not meeting this requirement.

RETURNED GOODS POLICY

Return shipments will be accepted and credit will be allowed, subject to the following provisions:

1. A Returned Material Authorization must be approved by Multiquip prior to shipment.
2. To obtain a Return Material Authorization, a list must be provided to Multiquip Parts Sales that defines item numbers, quantities, and descriptions of the items to be returned.
 - a. The parts numbers and descriptions must match the current parts price list.
 - b. The list must be typed or computer generated.
 - c. The list must state the reason(s) for the return.
 - d. The list must reference the sales order(s) or invoice(s) under which the items were originally purchased.
 - e. The list must include the name and phone number of the person requesting the RMA.
3. A copy of the Return Material Authorization must accompany the return shipment.
4. Freight is at the sender's expense. All parts must be returned freight prepaid to Multiquip's designated receiving point.

5. Parts must be in new and resalable condition, in the original Multiquip package (if any), and with Multiquip part numbers clearly marked.
6. The following items are not returnable:
 - a. Obsolete parts. (If an item is in the price book and shows as being replaced by another item, it is obsolete.)
 - b. Any parts with a limited shelf life (such as gaskets, seals, "O" rings, and other rubber parts) that were purchased more than six months prior to the return date.
 - c. Any line item with an extended dealer net price of less than \$5.00.
 - d. Special order items.
 - e. Electrical components.
 - f. Paint, chemicals, and lubricants.
 - g. Decals and paper products.
 - h. Items purchased in kits.
7. The sender will be notified of any material received that is not acceptable.
8. Such material will be held for five working days from notification, pending instructions. If a reply is not received within five days, the material will be returned to the sender at his expense.
9. Credit on returned parts will be issued at dealer net price at time of the original purchase, less a 15% restocking charge.
10. In cases where an item is accepted, for which the original purchase document can not be determined, the price will be based on the list price that was effective twelve months prior to the RMA date.
11. Credit issued will be applied to future purchases only.

PRICING AND REBATES

Prices are subject to change without prior notice. Price changes are effective on a specific date and all orders received on or after that date will be billed at the revised price. Rebates for price declines and added charges for price increases will not be made for stock on hand at the time of any price change.

Multiquip reserves the right to quote and sell direct to Government agencies, and to Original Equipment Manufacturer accounts who use our products as integral parts of their own products.

SPECIAL EXPEDITING SERVICE

A \$35.00 surcharge will be added to the invoice for special handling including bus shipments, insured parcel post or in cases where Multiquip must personally deliver the parts to the carrier.

LIMITATIONS OF SELLER'S LIABILITY

Multiquip shall not be liable hereunder for damages in excess of the purchase price of the item with respect to which damages are claimed, and in no event shall Multiquip be liable for loss of profit or good will or for any other special, consequential or incidental damages.

LIMITATION OF WARRANTIES

No warranties, express or implied, are made in connection with the sale of parts or trade accessories nor as to any engine not manufactured by Multiquip. Such warranties made in connection with the sale of new, complete units are made exclusively by a statement of warranty packaged with such units, and Multiquip neither assumes nor authorizes any person to assume for it any other obligation or liability whatever in connection with the sale of its products. Apart from such written statement of warranty, there are no warranties, express, implied or statutory, which extend beyond the description of the products on the face hereof.

OPERATION MANUAL

HERE'S HOW TO GET HELP

PLEASE HAVE THE MODEL AND SERIAL
NUMBER *ON-HAND* WHEN CALLING

UNITED STATES

Multiquip Corporate Office

18910 Wilmington Ave. Tel. (800) 421-1244
Carson, CA 90746 Fax (800) 537-3927
Contact: mq@multiquip.com

Mayco Parts

800-306-2926 Fax: 800-672-7877
310-537-3700 Fax: 310-637-3284

Service Department

800-421-1244 Fax: 310-537-4259
310-537-3700

MQ Parts Department

800-427-1244 Fax: 800-672-7877
310-537-3700 Fax: 310-637-3284

Warranty Department

800-421-1244, Ext. 279 Fax: 310-537-1173
310-537-3700, Ext. 279

Technical Assistance

800-478-1244 Fax: 310-631-5032

MEXICO

MQ Cipsa

Carr. Fed. Mexico-Puebla KM 126.5 Tel: (52) 222-225-9900
Momoxpan, Cholula, Puebla 72760 Mexico Fax: (52) 222-285-0420
Contact: pmastretta@cipsa.com.mx

CANADA

Multiquip

4110 Industriel Boul. Tel: (450) 625-2244
Laval, Quebec, Canada H7L 6V3 Fax: (450) 625-8664
Contact: jmartin@multiquip.com

UNITED KINGDOM

Multiquip (UK) Limited Head Office

Hanover Mill, Fitzroy Street, Tel: 0161 339 2223
Ashton-under-Lyne, Fax: 0161 339 3226
Lancashire OL7 0TL
Contact: sales@multiquip.co.uk

BRAZIL

Multiquip

Av. Evandro Lins e Silva, 840 - grupo 505 Tel: 011-55-21-3433-9055
Barra de Tijuca - Rio de Janeiro Fax: 011-55-21-3433-9055
Contact: cnavarro@multiquip.com.br, srentes@multiquip.com.br

© COPYRIGHT 2007, MULTIQUIP INC.

Multiquip Inc, the MQ logo and the Whiteman logo are registered trademarks of Multiquip Inc. and may not be used, reproduced, or altered without written permission. All other trademarks are the property of their respective owners and used with permission.

This manual MUST accompany the equipment at all times. This manual is considered a permanent part of the equipment and should remain with the unit if resold.

The information and specifications included in this publication were in effect at the time of approval for printing. Illustrations are based on the *MQ Whiteman HTN27/28 Ride-On Power Trowel*. Illustrations, descriptions, references and technical data contained in this manual are for guidance only and may not be considered as binding. Multiquip Inc. reserves the right to discontinue or change specifications, design or the information published in this publication at any time without notice and without incurring any obligations.

Your Local Dealer is:



Free Manuals Download Website

<http://myh66.com>

<http://usermanuals.us>

<http://www.somanuals.com>

<http://www.4manuals.cc>

<http://www.manual-lib.com>

<http://www.404manual.com>

<http://www.luxmanual.com>

<http://aubethermostatmanual.com>

Golf course search by state

<http://golfingnear.com>

Email search by domain

<http://emailbydomain.com>

Auto manuals search

<http://auto.somanuals.com>

TV manuals search

<http://tv.somanuals.com>