

REMINGTON®

PORTABLE FORCED AIR HEATERS

OWNER'S MANUAL

REMJ70

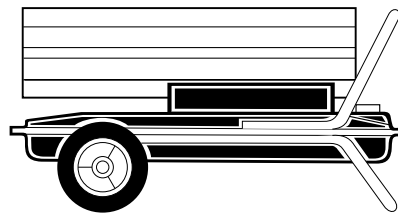

REMJ150

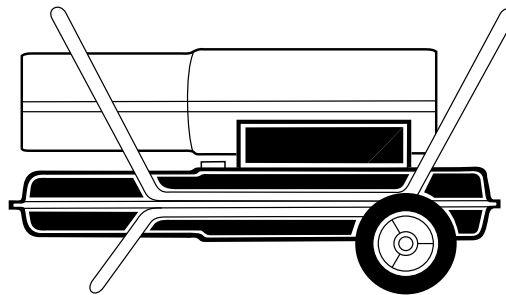

IMPORTANT

Read and understand this manual before assembling, starting or servicing heater. Improper use of heater can cause serious injury. Keep this manual for future reference.

CONTENTS

SECTION	PAGE
Safety Information	2
Product Identification	4
Unpacking	5
Assembly	5
Theory of Operation	6
Fuels	6
Ventilation	7
Operation	7
Storing, Transporting, or Shipping	8
Preventative Maintenance Schedule	8
Troubleshooting	9
Service Procedures	10
Upper Shell Removal	10
Fuel Filter (REM70)	10
Fuel Filter (REM150)	11
Spark Plug	11
Air Output, Air Intake, and Lint Filters	12
Pump Pressure Adjustment	12
Nozzle	13
Pump Rotor	14
Fan	15
Specifications	15
Illustrated Parts Breakdown and Parts List	16
REM70	16
REM150	18
Wheels and Handles	20
Wiring Diagram	21
Accessories	21

SAFETY INFORMATION

WARNINGS

IMPORTANT: Read this Owner's Manual carefully and completely before trying to assemble, operate, or service this heater. Improper use of this heater can cause serious injury or death from burns, fire, explosion, electrical shock, and carbon monoxide poisoning.

DANGER

Carbon monoxide poisoning may lead to death!

Carbon Monoxide Poisoning: Early signs of carbon monoxide poisoning resemble the flu, with headaches, dizziness, and/or nausea. If you have these signs, the heater may not be working properly. **Get fresh air at once!** Have heater serviced. Some people are more affected by carbon monoxide than others. These include pregnant women, persons with heart or lung disease or anemia, those under the influence of alcohol, and those at high altitudes.

Make certain you read and understand all Warnings. Keep this manual for reference. It is your guide to safe and proper operation of this heater.

SAFETY INFORMATION

Continued

WARNINGS *(Continued)*

- Use only kerosene to avoid risk of fire or explosion. Never use gasoline, naphtha, paint thinners, alcohol, or other highly flammable fuels.
- Fueling
 - a) Personnel involved with fueling shall be qualified and thoroughly familiar with the manufacturer's instructions and applicable federal, state, and local regulations regarding the safe fueling of heating units.
 - b) Only the type of fuel specified on the heater's data plate shall be used.
 - c) All flame, including the pilot light, if any, shall be extinguished and the heater allowed to cool, prior to fueling.
 - d) During fueling, all fuel lines and fuel-line connections shall be inspected for leaks. Any leaks shall be repaired prior to returning the heater to service.
 - e) At no time shall more than one day's supply of heater fuel be stored inside a building in the vicinity of the heater. Bulk fuel storage shall be outside the structure.
 - f) All fuel storage shall be located a minimum of 25 feet (762 cm) from heaters, torches, welding equipment, and similar sources of ignition (exception: the fuel reservoir integral with the heater unit).
 - g) Whenever possible, fuel storage shall be confined to areas where floor penetrations do not permit fuel to drip onto or be ignited by a fire at lower elevation.
 - h) Fuel storage shall be in accordance with the authority having jurisdiction.
- Never use heater where gasoline, paint thinner, or other highly flammable vapors are present.
- Follow all ordinances and codes when using heater.
- Heaters used in the vicinity of tarpaulins, canvas, or similar enclosure materials shall be located a safe distance from such materials. The recommended minimum safe distance is 10 feet (305 cm). It is further recommended that these enclosure materials be of a fire retardant nature. These enclosure materials shall be securely fastened to prevent them from igniting or from upsetting the heater due to wind action.
- Use only in well-vented areas. Before using heater, provide at least a three-square-foot opening of fresh, outside air for each 100,000 Btu/Hr of rating.
- Use only in places free of flammable vapors or high dust content.
- Use only the electrical voltage and frequency specified on model plate.
- Use only a grounded extension cord.
- Minimum heater clearances from combustibles:
 - Outlet: 8 Ft. (250 cm) Sides, Top, and Rear: 4 Ft. (125 cm)
- Locate heater on a stable and level surface if heater is hot or running or a fire may occur.
- When moving or storing heater, keep heater in a level position or fuel spillage may occur.
- Keep children and animals away from heater.
- Unplug heater when not in use.
- When used with thermostat, heater may start anytime.
- Never use heater in living or sleeping areas.
- Never block air inlet (rear) or air outlet (front) of heater.
- Never move, handle, refuel, or service a hot, operating, or plugged-in heater.
- Never attach duct work to front or rear of heater.

PRODUCT IDENTIFICATION

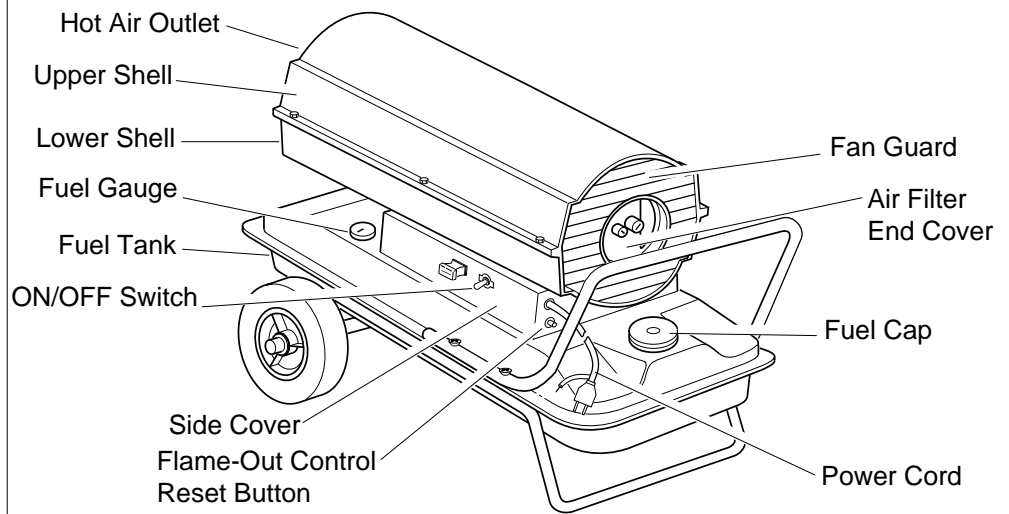

Figure 1 - REMJ70

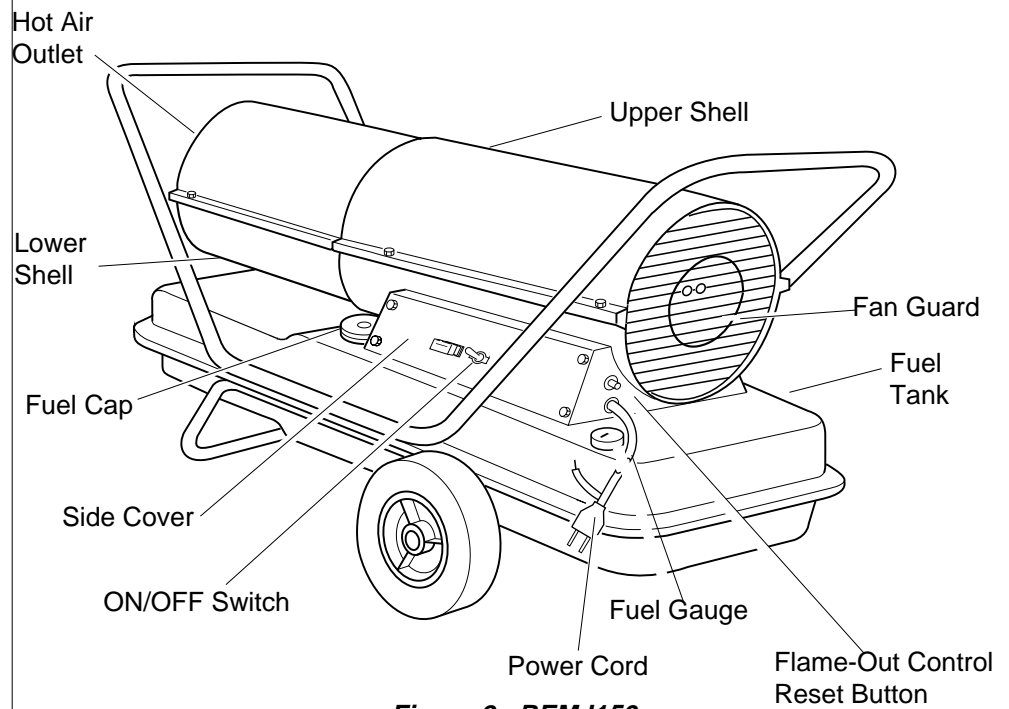

Figure 2 - REMJ150

UNPACKING

1. Remove all packing items applied to heater for shipment.
2. Remove all items from carton.
3. Check items for any shipping damage. If heater is damaged, promptly inform dealer where you bought heater.

ASSEMBLY

These models are furnished with wheels and handles. Wheels, handles, and the mounting hardware are found in the shipping carton.

Tools Needed

- Medium Phillips Screwdriver
- 3/8" Open or Adjustable Wrench
- Hammer

1. Slide axle through wheel support frame. Install wheels on axle.
IMPORTANT: When installing wheels, point extended hub of wheels toward wheel support frame (see Figure 3).
2. Place cap nuts on axle ends. Gently tap with hammer to secure.
3. Place heater on wheel support frame. Line up holes on fuel tank flange with holes on wheel support frame.
70 Model: Make sure hot air outlet end (front) of heater is over wheels.
150 Model: Make sure air inlet end (rear) of heater is over wheels.
4. Place handle or handles on top of fuel tank flange. Insert screws through handle(s), fuel tank flange, and wheel support frame. Attach nut finger tight after each screw is inserted.
5. After all screws are inserted, tighten nuts firmly.

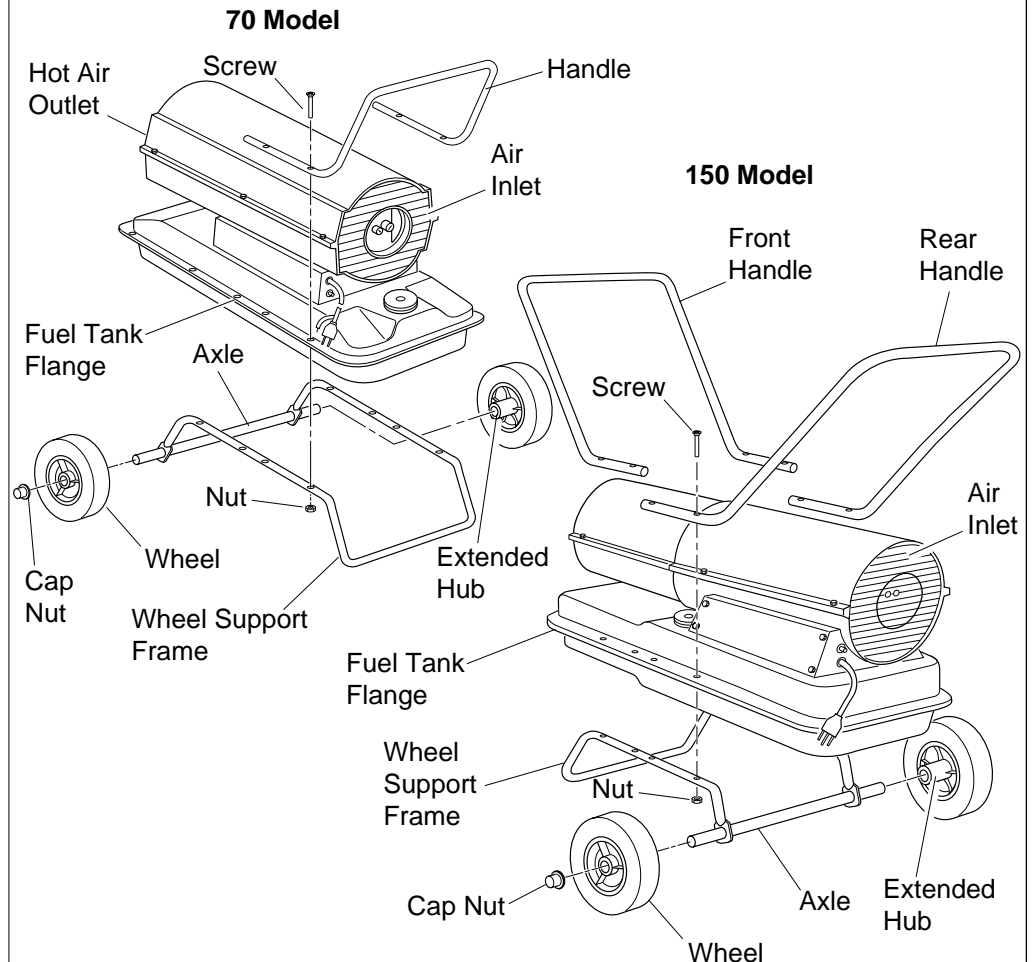

Figure 3 - Wheel and Handle Assembly

THEORY OF OPERATION

The Fuel System: The air pump forces air through the air line. The air is then pushed through the burner head nozzle. This air causes fuel to lift from the tank. A fine mist of fuel is sprayed into the combustion chamber.

The Air System: The motor turns the fan. The fan pushes air into and around the combustion chamber. This air is heated and provides a stream of clean, hot air.

The Ignition System: The electronic ignitor sends voltage to the spark plug. The spark plug ignites the fuel and air mixture.

The Flame-Out Control System: This system causes the heater to shut down if the flame goes out.

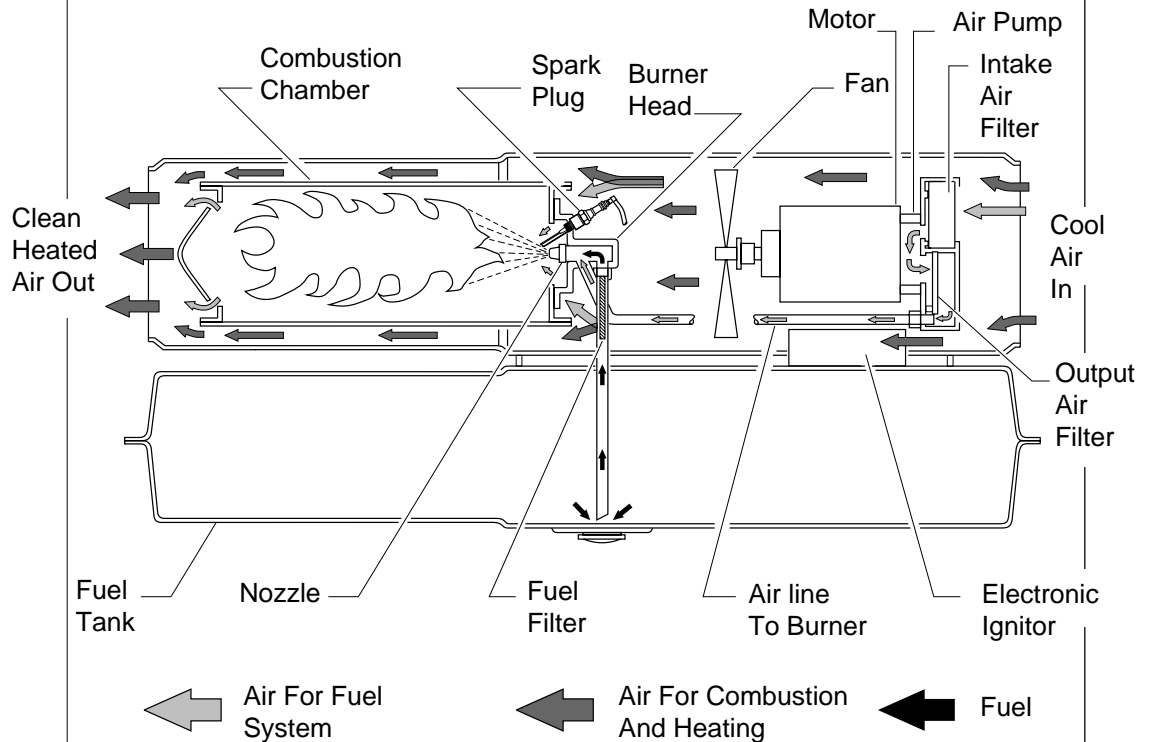

Figure 4 - Cross Section Operational View

FUELS

⚠ WARNING

Use only kerosene or No. 1 fuel oil to avoid risk of fire or explosion. Never use gasoline, naphtha, paint thinners, alcohol or other highly flammable fuels.

Do not use heavy fuels such as No. 2 fuel oil or No. 2 Diesel. Using heavy fuels will result in:

- clogged fuel filter and nozzle
- carbon build up on spark plug
- use of non-toxic anti-icer in fuel during very cold weather

IMPORTANT: Use a KEROSENE ONLY container. Be sure storage container is clean. Foreign matter such as rust, dirt, or water will cause the flame-out control to shut down heater. Foreign matter may also require you to clean fuel system often.

VENTILATION

⚠️ WARNING

Follow the minimum fresh, outside air ventilation requirements. If proper fresh, outside air ventilation is not provided, carbon monoxide poisoning can occur. Provide proper fresh, outside air ventilation before running heater.

Provide a fresh air opening of at least three square feet (2800 square cm) for each 100,000 Btu/Hr rating. Provide extra fresh air if more heaters are being used.

Example: A 150,000 Btu/Hr heater requires one of the following:

- a two-car garage door (5 m wide opening) raised 8.6 cm.
- a single-car garage door (2.75 m wide opening) raised 15.3 cm.
- two, 76.2 cm wide windows raised 28 cm.

OPERATION

⚠️ WARNING

Review and understand the warnings in the *Safety Information Section*, page 3. They are needed to safely operate this heater. Follow all local codes when using this heater.

To Start Heater

1. Follow all ventilation and safety information.
2. Fill fuel tank with kerosene.
3. Attach fuel cap.
4. Plug power cord into grounded receptacle with 100 Volts, 50 or 60 Hz.
5. Turn ON/OFF switch to "ON".

Extension Cord Wire Size Requirements

Up to 100 feet (30.5 meters) long, use 16 AWG (1.0 mm²) conductor

101 to 200 feet (30.6 to 61 meters) long, use 14 AWG (1.5 mm²) conductor

If heater does not start, push in flame-out control reset button (see Figures 5 and 6).

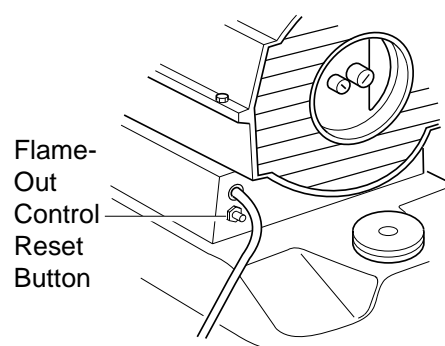

Figure 5 - Flame-Out Control Reset Button (REMJ70)

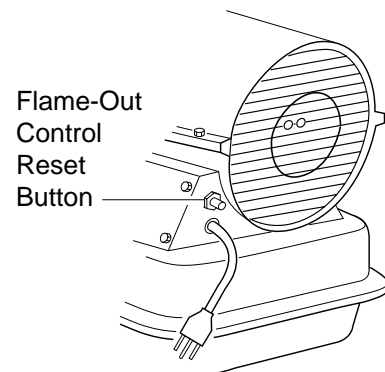

Figure 6 - Flame-Out Control Reset Button (REMJ150)

Continued

OPERATION

Continued

STORING, TRANSPORTING, OR SHIPPING

PREVENTATIVE MAINTENANCE SCHEDULE

To Stop Heater

1. Turn ON/OFF switch to "OFF."
2. Unplug power cord from outlet.

To Restart Heater

1. Wait 2 minutes after stopping heater.
2. Repeat steps under *To Start Heater*, page 7.

Note: If shipping, transport companies require fuel tanks to be empty.

1. Drain fuel tank by removing drain plug on underside of fuel tank.
2. Replace drain plug.
3. If any debris is noted in old fuel, add 1 or 2 quarts of clean kerosene to tank, stir, and drain again. This will prevent excess debris from clogging filters during future use.
4. Replace drain plug. Properly dispose of old and dirty fuel. Check with local automotive service stations that recycle oil.
5. If storing, store heater in dry place. Make sure storage place is free of dust and corrosive fumes.

IMPORTANT: Do not store kerosene over summer months for use during next heating season. Using old fuel could damage heater.

WARNING

Never service heater while it is plugged in, operating, or hot. Severe burns and electrical shock can occur.

<u>Item</u>	<u>How Often</u>	<u>How To</u>
Fuel tank	Flush every 150-200 hours of operation or as needed.	See <i>Storing, Transporting, or Shipping</i> , above.
Air output and	Replace every 500 hours of lint filters operation or once a year.	See <i>Air Output, Air Intake, and Lint Filters</i> , page 12.
Air intake filter	Wash and dry with soap and water every 500 hours of operation or as needed.	See <i>Air Output, Air Intake, and Lint Filters</i> , page 12.
Fuel filter	Clean twice a heating season or as needed.	See <i>Fuel Filter</i> , pages 10 and 11.
Spark plug	Clean and regap every 600 hours operation or replace as needed.	See <i>Spark Plug</i> , page 11.
Fan blades	Clean every season or as needed.	See <i>Fan</i> , page 15.
Motor	Not required/permanently lubricated	

TROUBLE-SHOOTING

WARNING

Never service heater while it is plugged in, operating, or hot. Severe burns and electrical shock can occur.

<u>OBSERVED FAULT</u>	<u>POSSIBLE CAUSE</u>	<u>REMEDY</u>
Heater ignites, but flame-out control shuts off heater after a short period of time	Wrong pump pressure	See <i>Pump Pressure Adjustment</i> , page 12.
	Dirty air output, air intake, and lint filters	See <i>Air Output, Air Intake and Lint Filters</i> , page 12.
	Dirty fuel filter	See <i>Fuel Filter</i> , pages 10 and 11.
	Dirt in nozzle	See <i>Nozzle</i> , page 13.
	Dirty photocell lens	Clean photocell lens.
	Bad flame-out control	Replace flame-out control.
Heater will not ignite, but motor runs for a short period of time.	Wrong pump pressure	See <i>Pump Pressure Adjustment</i> , page 12.
	Carbon deposits on spark plug and/or improper gap	See <i>Spark Plug</i> , page 11.
	Dirty fuel filter	See <i>Fuel Filter</i> , pages 10 and 11.
	Dirt in nozzle	See <i>Nozzle</i> , page 13.
	Water in fuel tank	Drain and flush fuel tank with clean kerosene. See <i>Storing, Transporting, or Shipping</i> , page 8.
	WARNING: High voltage!	
Motor does not start when heater is plugged in, fan rotates slowly or does not turn.	Electronic ignitor not grounded (earthed)	Make sure electronic ignitor mounting is tight.
	Bad electronic ignitor	Replace electronic ignitor.
	ON/OFF switch in "OFF" position	Switch to "ON" position
	Flame-out control not reset	Reset flame-out control button, see Figures 5 and 6, page 7.
	Binding pump rotor	If fan is hard to turn, see <i>Pump Rotor</i> , page 14.

SERVICE PROCEDURES

Upper Shell Removal

1. Remove screws along each side of heater using 5/16" nut-driver. These screws attach upper and lower shells together.
2. Lift upper shell off.
3. Remove fan guard.

Fuel Filter

(REM J70)

1. Remove side cover screws using 5/16" nut-driver.
2. Remove side cover.
3. Pull rubber fuel line off fuel filter neck.
4. Carefully pry bushing and fuel filter out of fuel tank.
5. Wash fuel filter with clean fuel and replace in tank.
6. Attach rubber fuel line to fuel filter neck.
7. Replace side cover.

WARNING

Never service heater while it is plugged in, operating, or hot. Severe burns and electrical shock can occur.

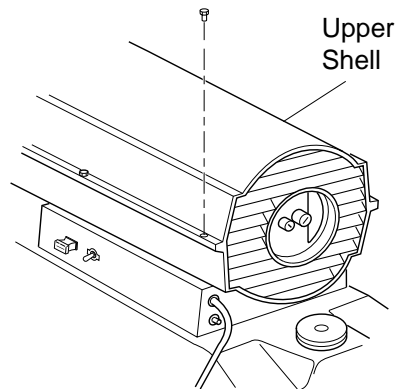

Figure 7 - Upper Shell Removal (REM J70)

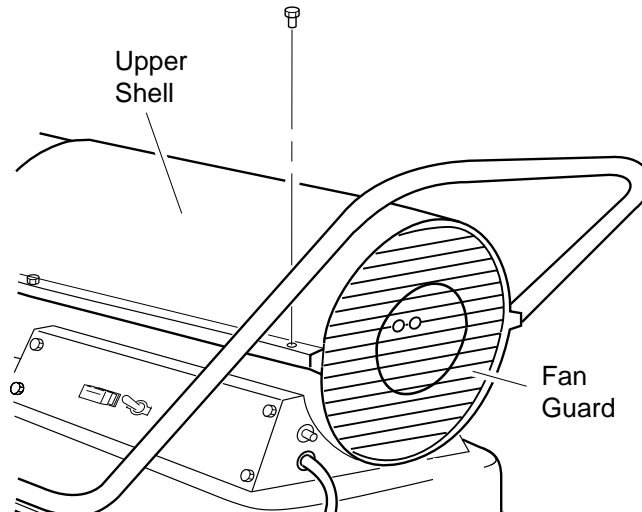

Figure 8 - Upper Shell Removal (REM J150)

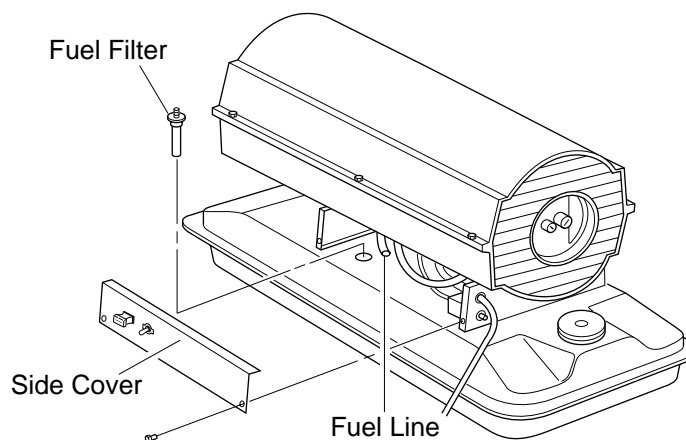

Figure 9 - Fuel Filter Removal (REM J70)

Fuel Filter

(REMJ150)

1. Remove side cover screws using 5/16" nut-driver.
2. Remove side cover.
3. Pull upper fuel line off fuel filter neck.
4. Carefully pry bushing, lower fuel line, and fuel filter out of fuel tank.
5. Wash fuel filter with clean fuel and replace in tank.
6. Attach upper fuel line to fuel filter neck.
7. Replace side cover.

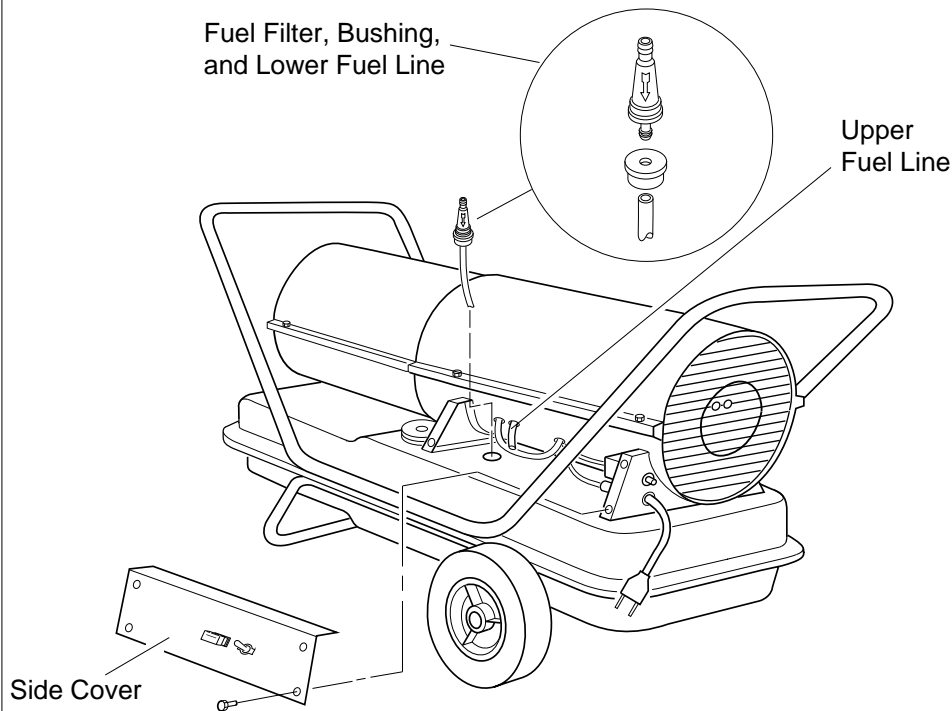

Figure 10 - Fuel Filter Removal (REMJ150)

Spark Plug

1. Remove upper shell (see page 10).
2. Remove fan (see page 15).
3. Remove spark plug wire from spark plug.
4. Remove spark plug from burner head using 13/16" open-end wrench.
5. Clean and regap spark plug electrodes as follows:
REMJ70: .085" (2.2 mm) gap,
REMJ150: .085" (2.2 mm) gap.
6. Install spark plug in burner head.
7. Attach spark plug wire to spark plug.
8. Replace fan (see page 15).
9. Replace fan guard and upper shell.

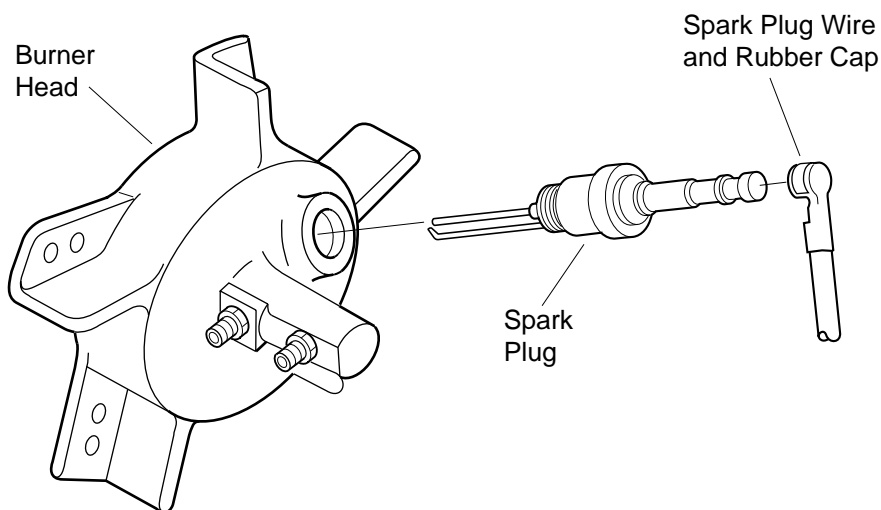

Figure 11 - Spark Plug Removal

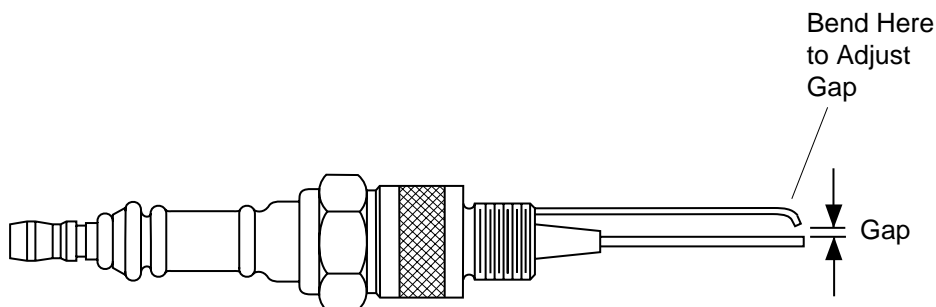

Figure 12 - Spark Plug Gap

Air Output, Air Intake, and Lint Filters

1. Remove upper shell (see page 10).
2. Remove filter end cover screws using 5/16" nut-driver.
3. Remove filter end cover.
4. Replace air output and lint filters.
5. Wash or replace air intake filter (see *Preventative Maintenance Schedule*, page 8).
6. Replace filter end cover.
7. Replace fan guard and upper shell.

IMPORTANT: Do not oil filters.

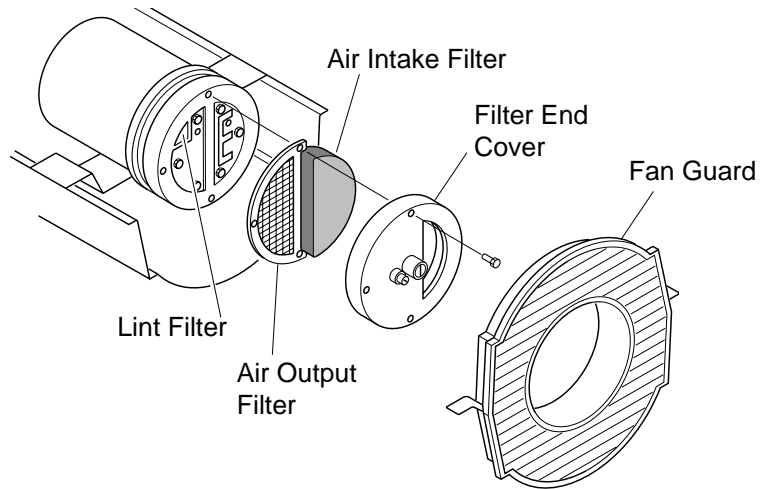

Figure 13 - Air Output, Air Intake, and Lint Filters (REMJ70)

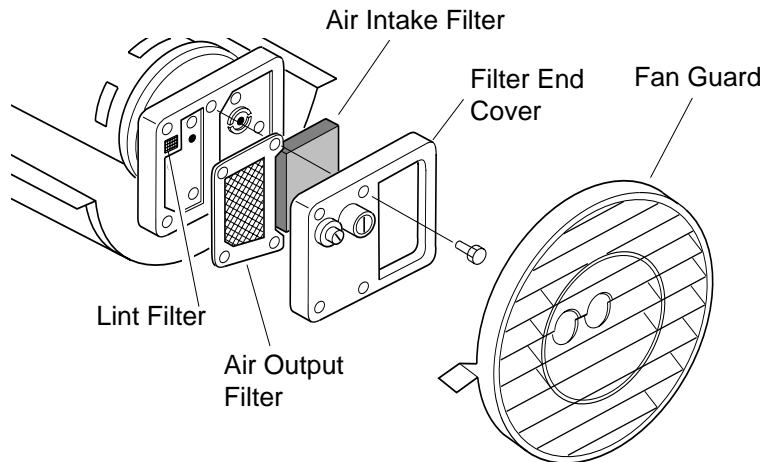

Figure 14 - Air Output, Air Intake, and Lint Filters (REMJ150)

Pump Pressure Adjustment

1. Remove pressure gauge plug from filter end cover.
2. Install accessory pressure gauge (part number HA1180).
3. Start heater (see *Operation*, page 7). Allow motor to reach full speed.
4. Adjust pressure. Turn relief valve to right to increase pressure. Turn relief valve to left to decrease pressure. See specifications at right for correct pressure for each model.
5. Remove pressure gauge. Replace pressure gauge plug in filter end cover.

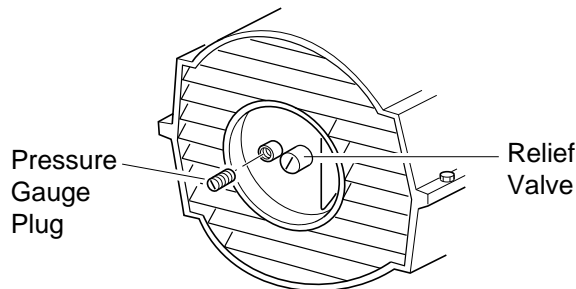

Figure 15 - Pressure Gauge Plug Removal

Model	Pump Pressure (PSI - kg/cm²)
REMJ70	5.0 - .35 @ 50Hz
	5.4 - .38 @ 60Hz
REMJ150	5.0 - .35 @ 50Hz
	5.3 - .37 @ 60Hz

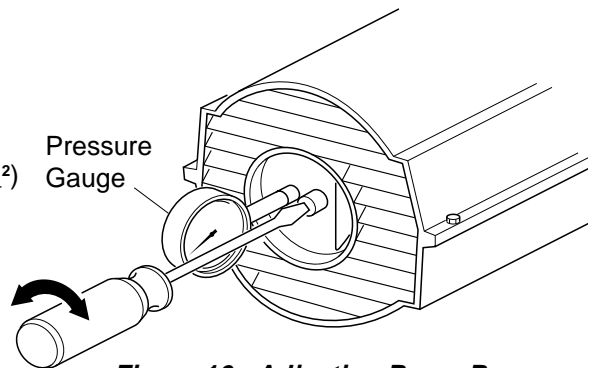

Figure 16 - Adjusting Pump Pressure

Nozzle

1. Remove upper shell (see page 10).
2. Remove fan (see page 15).
3. Remove fuel and air line hoses from burner head.
4. Remove spark plug wire from spark plug.
5. Remove spark plug from burner head using 13/16" open-end wrench.
6. Remove three screws using 5/16" nut-driver and remove burner head from combustion chamber.
7. Place burner head into vise and lightly tighten.
8. Carefully remove nozzle from burner head using 5/8" socket wrench (see Figure 18).
9. Blow compressed air through face of nozzle. This will free any dirt in nozzle area.
10. Inspect nozzle seal for damage.
11. Replace nozzle into burner head and tighten firmly (80-110 inch-pounds/9.1-12.4 n-m).
12. Attach burner head to combustion chamber.
13. Install spark plug in burner head.
14. Attach spark plug wire to spark plug.
15. Attach fuel and airline hoses to burner head.
16. Replace fan (see page 15).
17. Replace fan guard and upper shell.

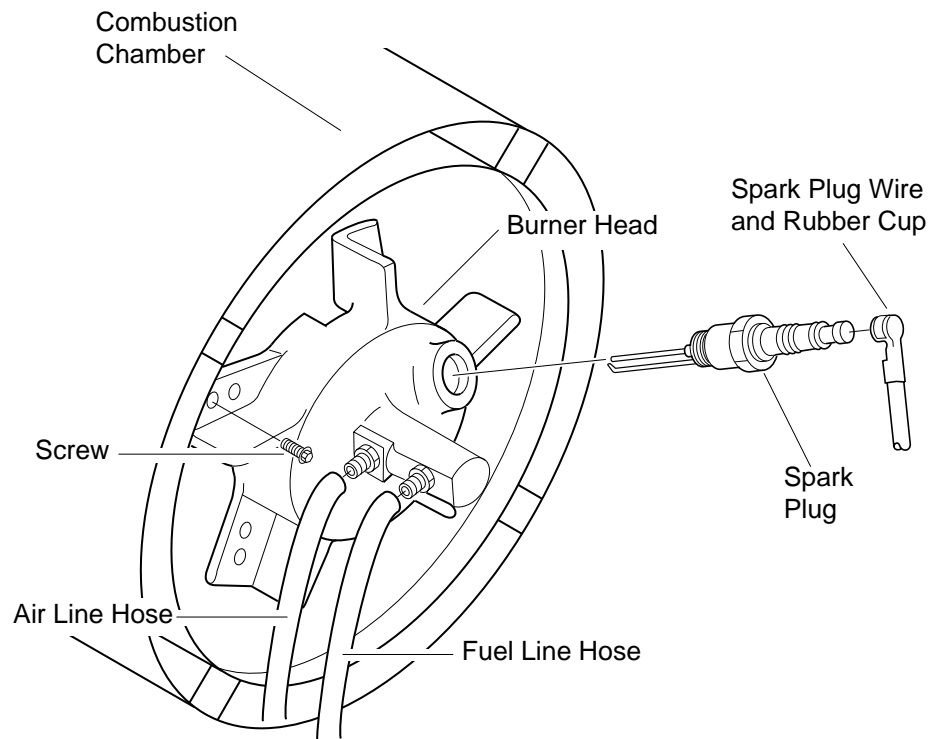

Figure 17 - Removing Burner Head

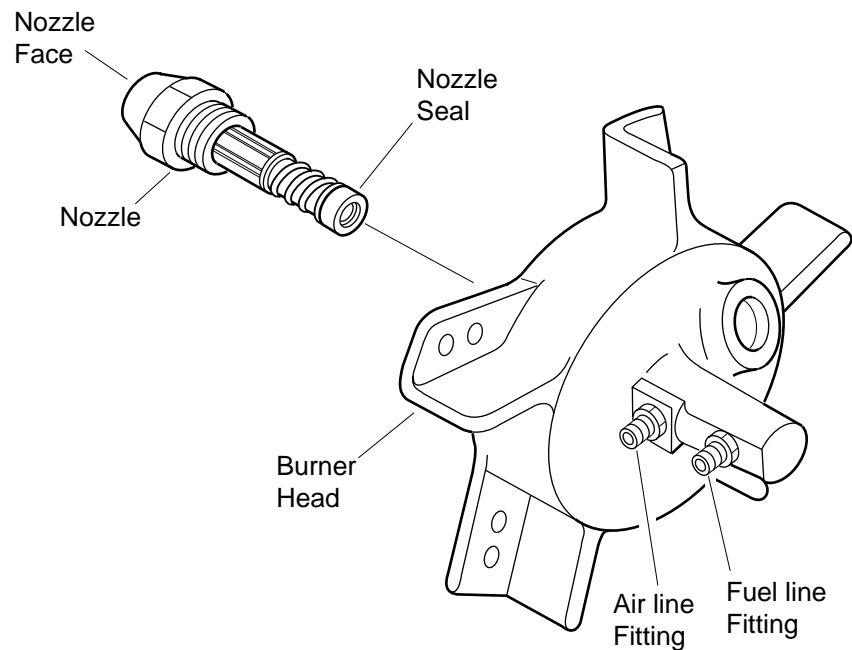

Figure 18 - Removing Nozzle

Pump Rotor

(Procedure if rotor is binding)

1. Remove upper shell (see page 10).
2. Remove filter end cover screws using 5/16" nut-driver.
3. Remove filter end cover and air filters.
4. Remove pump plate screws using 5/16" nut-driver.
5. Remove pump plate.
6. Remove rotor, insert, and blades.
7. Check for debris in pump. If debris is found, blow out with compressed air.
8. Install insert and rotor.
9. Check gap on rotor. Adjust to .003"/.004" (.076/.101 mm) if needed (see Figure 21).

Note: Rotate rotor one full turn to insure the gap is .003"/.004" (.076/.101 mm) at tightest position. Adjust if needed.

10. Install blades, pump plate, air filters, and filter end cover.
11. Replace fan guard and upper shell.
12. Adjust pump pressure (see page 12).

Note: If rotor is still binding, proceed as follows.

13. Perform steps 1 through 6 above.
14. Place fine grade sandpaper (600 grit) on flat surface. Sand rotor lightly in "figure 8" motion four times (see Figure 22).
15. Reinstall insert and rotor.
16. Perform steps 10 through 12 above.

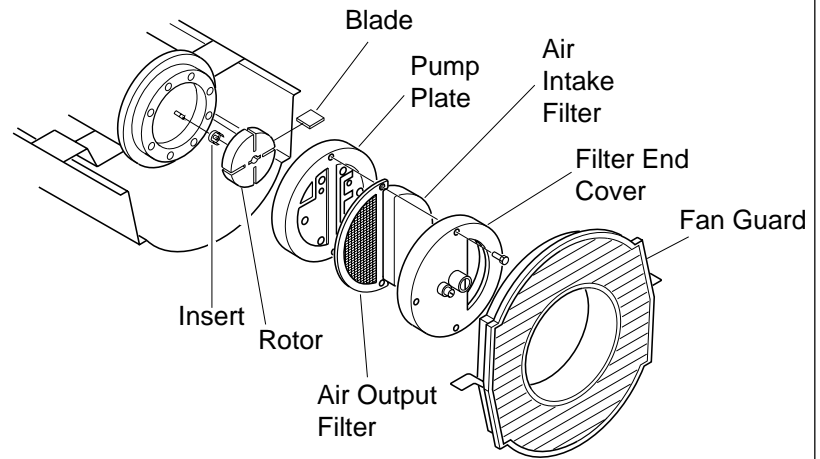

Figure 19 - Rotor Location (REMJ70)

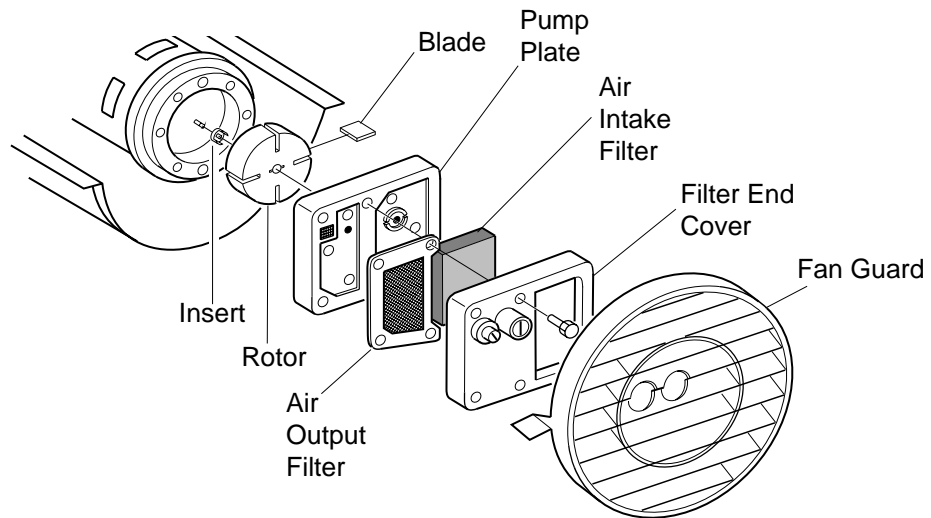

Figure 20 - Rotor Location (REMJ150)

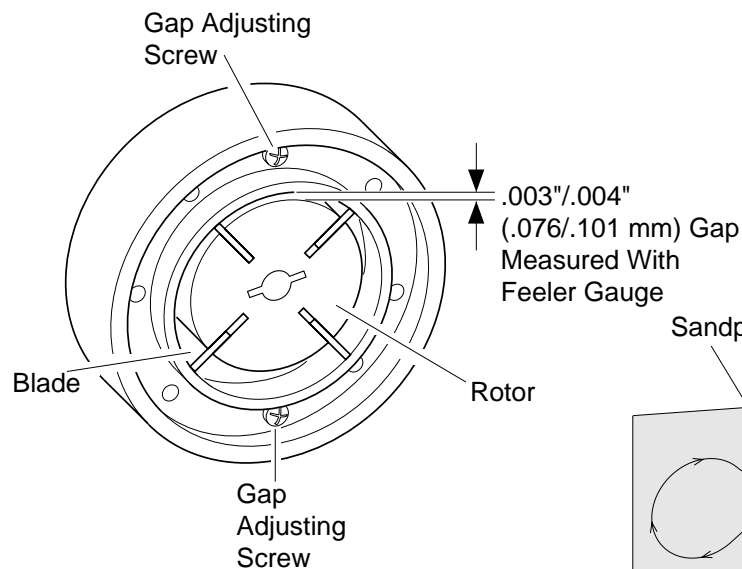

Figure 21 - Gap Adjusting Screw Locations

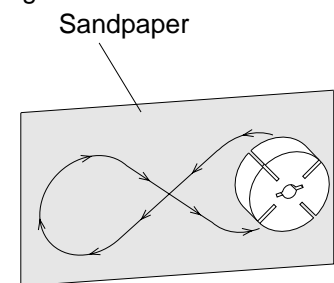

Figure 22 - Sanding Rotor

Fan

IMPORTANT: Remove fan from motor shaft before removing motor from heater. The weight of the motor resting on the fan could damage the fan pitch.

1. Remove upper shell (see page 10).
2. Use 1/8" allen wrench to loosen setscrew which holds fan to motor shaft.
3. Slip fan off motor shaft.
4. Clean fan using a soft cloth moistened with kerosene or solvent.
5. Dry fan thoroughly.
6. Replace fan on motor shaft. Place fan hub flush with end of motor shaft (see Figure 24).
7. Place setscrew on flat of shaft. Tighten setscrew firmly (40-50 inch-pounds/ 4.5-5.6 n-m).
8. Replace fan guard and upper shell.

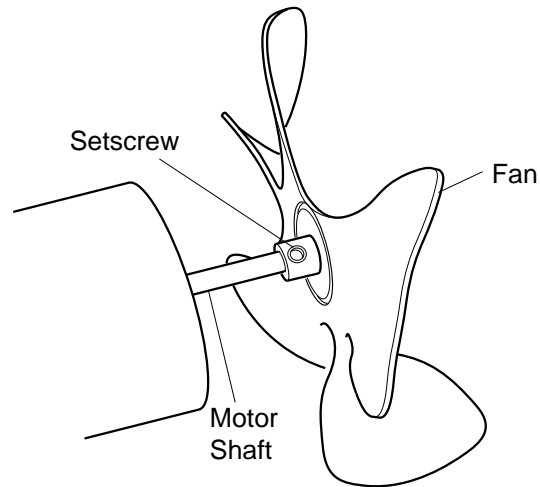

Figure 23 - Fan, Motor Shaft, and Setscrew Location

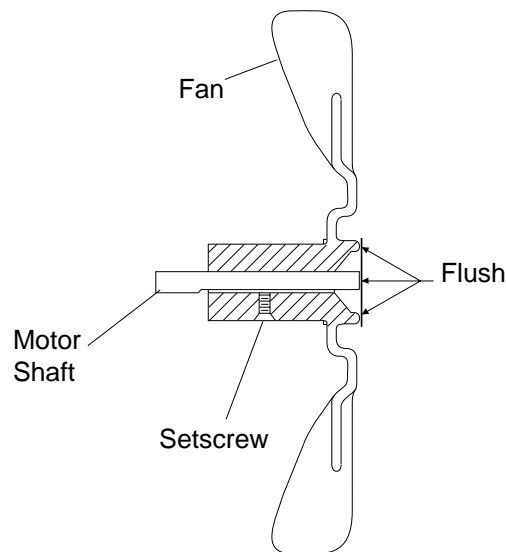

Figure 24 - Fan Cross Section

SPECIFICATIONS

	REM70	REM150
Heat Output (Kcal/hr)	17,640	38,500
Fuel Consumption (liters/hr)	1.9	4.2
Fuel Tank Capacity (liters)	16	47
Run Time per Tank (hours)	8	11
Hot Air Output (m ³ /min)	6.7@50Hz 7.5@60Hz	12.4@50Hz 13.7@60Hz
Voltage	100	100
Frequency (Hz)	50/60	50/60
Wattage (W)	200	340
Pump Pressure (kg/cm ²)	0.35@50Hz 0.38@60Hz	0.35@50Hz 0.37@60Hz
(PSI)	5.0@50Hz 5.4@60Hz	5.0@50Hz 5.3@60Hz

ILLUSTRATED PARTS BREAKDOWN

REM J70

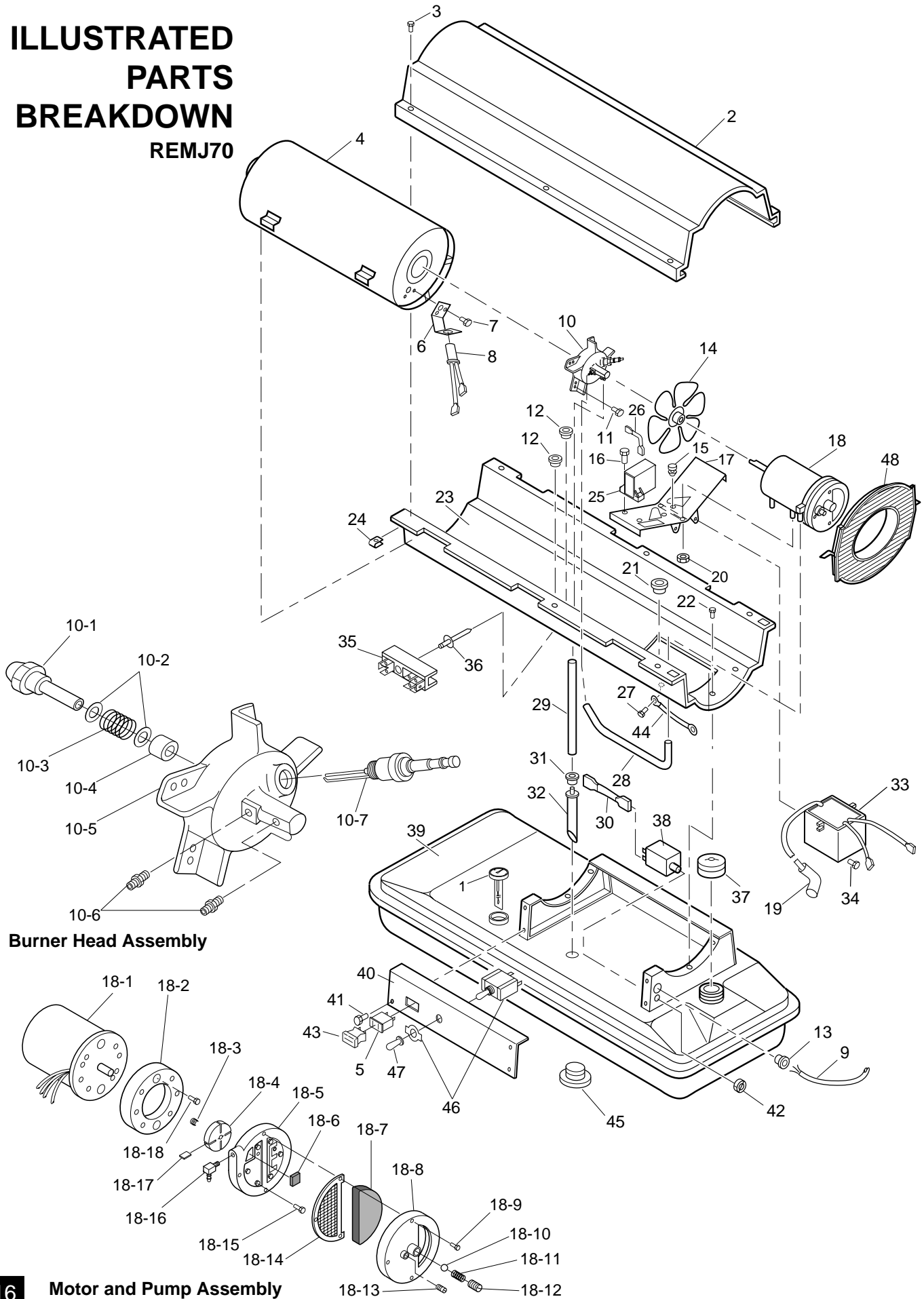

Burner Head Assembly

PARTS LIST

REM70

This list contains replaceable parts used in your heater. When ordering parts, be sure to provide the correct model and serial numbers (from the model plate), then the part number and description of the desired part.

KEY NO.	PART NUMBER	PART DESCRIPTION	QTY.	KEY NO.	PART NUMBER	PART DESCRIPTION	QTY.
1	097190-01	Fuel Gauge	1	19	M50050	Rubber Boot	1
2	098511-188	Upper Shell	1	20	NTC-4C	Hex locknut	2
3	100647-01	Screw, #10-16 x 1/2"	6	21	M50104-02	Shorty Bushing (wires)	1
4	098512-41	Combustion Chamber	1	22	M11084-26	Screw, #10-16 x 3/8"	6
5	097202-01	Receptacle	1	23	098511-81	Lower Shell	1
6	M16660	Photocell Bracket	1	24	M11271-8	Clip Nut	6
7	M10908-2	Screw, #6-32 x 3/8"	2	25	097061-01	Relay (motor start)	1
8	HA3019	Photocell Assembly	1	26	079010-18	Wire Assembly (red 16")	1
9	102330-01	Power Cord	1	27	M10908-14	Screw, #8-32 x 3/8"	1
10	**	Burner Head Assembly	1	28	M29652-04	Rubber Airline	1
10-1	100735-14	Nozzle	1	29	079973-01	Fuel Line	1
10-2	M10659-1	Nozzle Seal Washer	2	30	M16841-57	Wire Assembly (red 8 1/2")	1
10-3	M10809-1	Nozzle Seal Spring	1	31	M10990-3	Rubber Bushing	1
10-4	M8882	Nozzle Seal Sleeve	1	32	M50876-05	Fuel Filter Assembly (Includes bushing)	1
10-5	M51098-02	Burner Head Body	1	33	101901-09	Electronic Ignitor	1
10-6	M50820-01	Barb Fitting	2	34	M11084-29	Screw, #10-16 x 3/4"	2
10-7	M10962-2	Spark Plug	1	35	099125-03	Terminal Board	1
11	M11084-27	Screw, #10-16 x 1/2"	3	36	099157-01	Rivet	1
12	M30865-02	Bushing	2	37	097702-01	Fuel Tank Cap	1
13	099492-01	Strain Relief Bushing	1	38	097997-02	Flame-Out Control	1
14	097200-01	Fan	1	39	098513-57	Fuel Tank	1
15	M50631	Rubber Bumper	2	40	097194-02AA	Side Cover	1
16	M15823-39	Screw, #8-18 x 1/2"	2	41	M11084-26	Screw, #10-16 x 3/8"	2
17	101205-01	Motor and Relay Bracket	1	42	099177-01	Hex Nut	1
18	**	Motor and Pump Assembly	1	43	097274-01	Jumper Plug	1
18-1	097286-02	Motor	1	44	M9900-192	Wire Assembly (green 16")	1
18-2	079975-02	Pump Body	1	45	M27417	Drain Plug	1
18-3	M22009	Insert	1	46	098226-01	ON/OFF Switch	1
18-4	M22456-1	Rotor	1	47	097196-02	Switch Seal	1
18-5	M29608	End Pump Cover	1	48	M51105-01	Fan Guard	1
18-6	M29632	Lint Filter	1				
18-7	M29633	Intake Filter	1				
18-8	M29609	End Filter Cover	1				
18-9	M12461-31	Screw, #10-32 x 1"	3				
18-10	M8940	Steel Ball (1/4" Dia.)	1				
18-11	M10993-1	Pressure Relief Spring	1				
18-12	M27694	Adjusting Screw	1				
18-13	M22997	Plug	1				
18-14	M29612-01	Output Filter	1				
18-15	M12461-31	Screw, #10-32 x 1"	6				
18-16	M50016	Elbow, 90° (Barb Fitting)	1				
18-17	M8643	Blade	4				
18-18	FHPF3-5C	Screw, #10-32 x 5/8"	2				
PARTS AVAILABLE - NOT SHOWN							
					HA2210	Filler Neck Screen	1
					097208-31	Nameplate Decal	1
					098070-02	Warning Decal	1
					M9900-170	Wire Assembly (Black 12")	1
					M16841-20	Wire Assembly (Black 7")	1

**Not available as an assembly, order parts separately.

ILLUSTRATED PARTS BREAKDOWN

REMJ150

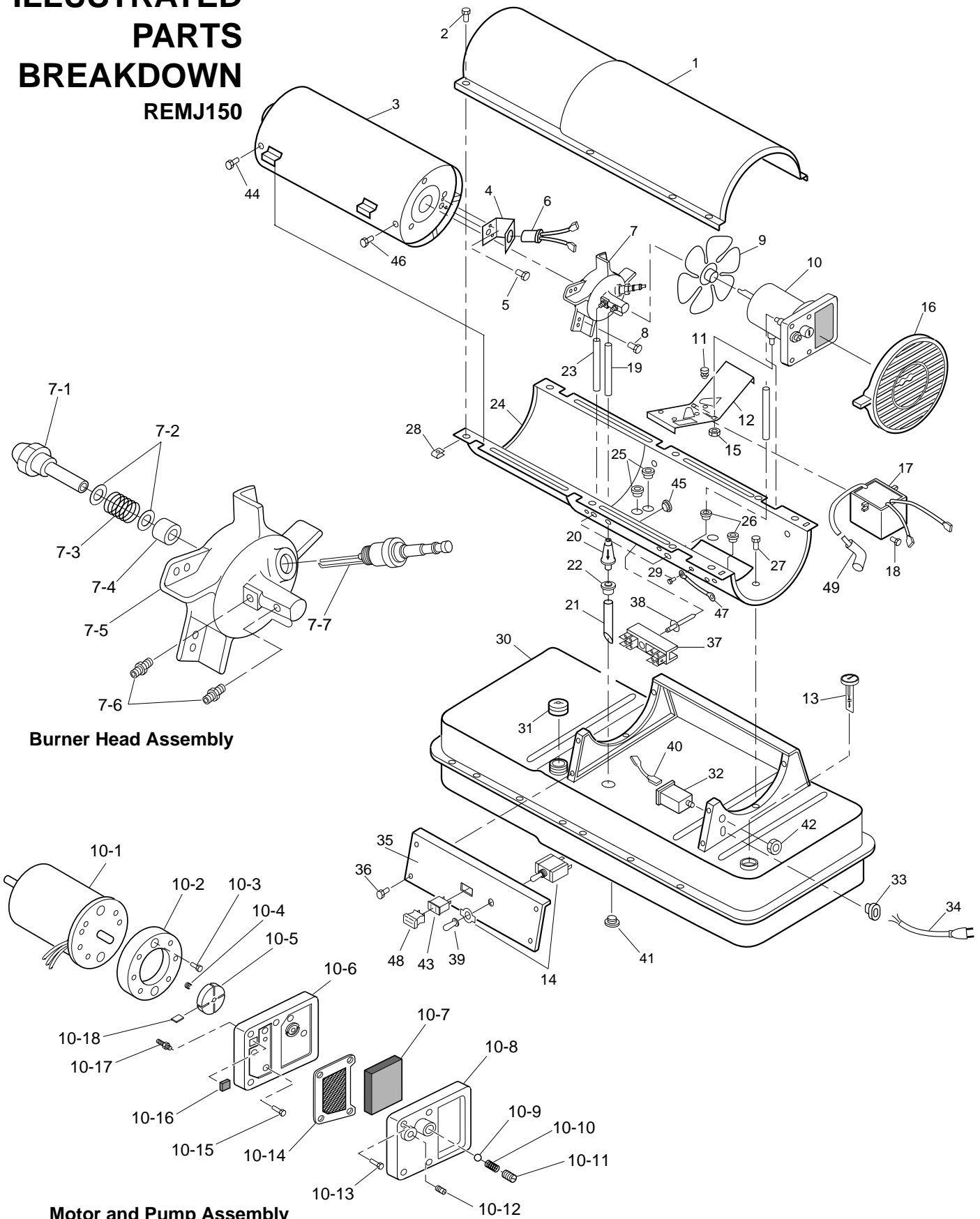

Burner Head Assembly

Motor and Pump Assembly

PARTS LIST

REMJ150

This list contains replaceable parts used in your heater. When ordering parts, be sure to provide the correct model and serial numbers (from the model plate), then the part number and description of the desired part.

KEY NO.	PART NUMBER	DESCRIPTION	QTY.	KEY NO.	PART NUMBER	DESCRIPTION	QTY.
1	098511-66	Upper Shell	1	17	101901-03	Electronic Ignitor	1
2	100647-01	Screw, #10-16 x 1/2"	8	18	M11084-29	Screw, #10-16 x 3/4"	2
3	098512-36	Combustion Chamber	1	19	M51345-01	Fuel Line	1
4	099229-01	Photocell Bracket	1	20	M51150-01	Fuel Filter	1
5	M10908-2	Screw, #6-32 x 3/8"	2	21	M51151-02	Fuel Line Tube	1
6	HA3019	Photocell Assembly	1	22	M10990-3	Rubber Bushing	1
7	**	Burner Head Assembly	1	23	M50814-03	Air Line	1
7-1	100735-07	Nozzle	1	24	098511-82	Lower Shell	1
7-2	M10659-1	Nozzle Washer	2	25	M50104-03	Bushing	2
7-3	M10809-1	Nozzle Spring	1	26	M50104-01	Bushing	2
7-4	M8882	Nozzle Sleeve	1	27	M11084-27	Screw, #10-16 x 1/2"	6
7-5	M50924-08	Burner Head Body	1	28	M11271-8	Clip Nut	8
7-6	M50820-02	Barb Fitting	2	29	M10908-14	Screw, #8-32 x 3/8"	1
7-7	HA3012	Spark Plug	1	30	098513-81	Fuel Tank	1
8	M11084-27	Screw, #10-16 x 1/2"	3	31	097702-01	Fuel Tank Cap	1
9	102042-01	Fan	1	32	097997-02	Flame-Out Control	1
10	**	Motor and Pump Assembly	1	33	099492-01	Strain Relief Bushing	1
10-1	102234-01	Motor	1	34	102330-01	Power Cord	1
10-2	079975-02	Pump Body	1	35	M51077-07AA	Side Cover	1
10-3	FHPF3-5C	Screw #10-32 x 5/8"	2	36	M11084-27	Screw, #10-16 x 1/2"	4
10-4	M22009	Rotor Insert	1	37	099125-02	Terminal Board	1
10-5	M22456-1	Pump Rotor	1	38	099157-02	Rivet	1
10-6	M50545	Pump End Cover	1	39	097196-02	Switch Seal	1
10-7	M12179	Intake Filter	1	40	M16841-57	Wire Assembly (Red, 8 1/2")	1
10-8	M16545	Filter End Cover	1	41	M27417	Drain Plug (Includes "O" Ring)	1
10-9	M8940	Steel Ball, 1/4" diameter	1	42	099177-01	Hex Nut	1
10-10	M10993-1	Relief Spring	1	43	097202-01	Receptacle	1
10-11	M27694	Adjusting Screw	1	44	099230-01	Screw, #10-16 x 3/8"	2
10-12	M22997	Plug	1	45	099213-01	Button Plug	1
10-13	M12461-31	Screw #10-32 x 1"	4	46	M11084-27	Screw, #10-16 x 1/2"	2
10-14	M12244-1	Output Filter	1	47	M9900-192	Wire Assembly (Green, 16")	1
10-15	M12461-31	Screw, #10-32 x 1"	6	48	097274-01	Jumper Plug	1
10-16	M11637	Lint Filter	1	49	M50050	Rubber Boot	1
10-17	M50820-02	Barb Fitting	1				
10-18	M8643	Blade	4				
11	M50631	Rubber Bumper	2	PARTS AVAILABLE - NOT SHOWN			
12	101206-01	Motor Mounting Bracket	1				
13	097190-03	Fuel Gauge	1		HA2210	Filler Neck Screen	1
14	098226-01	ON/OFF Switch	1		097208-32	General Information Decal	1
15	NTC-4C	Hex Lock Nut, 1/4-20	2		098070-02	Warning Decal	1
16	M51114-01	Fan Guard	1		M16841-20	Wire Assembly (Black 7")	1

** Not available as an assembly. Order parts separately.

WHEELS AND HANDLES

KEY NO.	PART NUMBER	PART DESCRIPTION	REM J70 QTY.	REM J150 QTY.
1	097198-02	Handle (Rear)	1	—
	097777-03	Handles	—	2
2	M12345-33	Screw, #10-24 x 1 3/4"	4	8
3	097197-02	Wheel Support Frame	1	—
	M12831-3	Wheel Support Frame	—	1
4	NTC-3C	Hex Nut, #10-24	4	8
5	097766-01	Wheel	2	2
6	M28526	Cap Nut	2	2
7	M51015-04	Axle	1	—
	M16801-2	Axle	—	1

REM J70

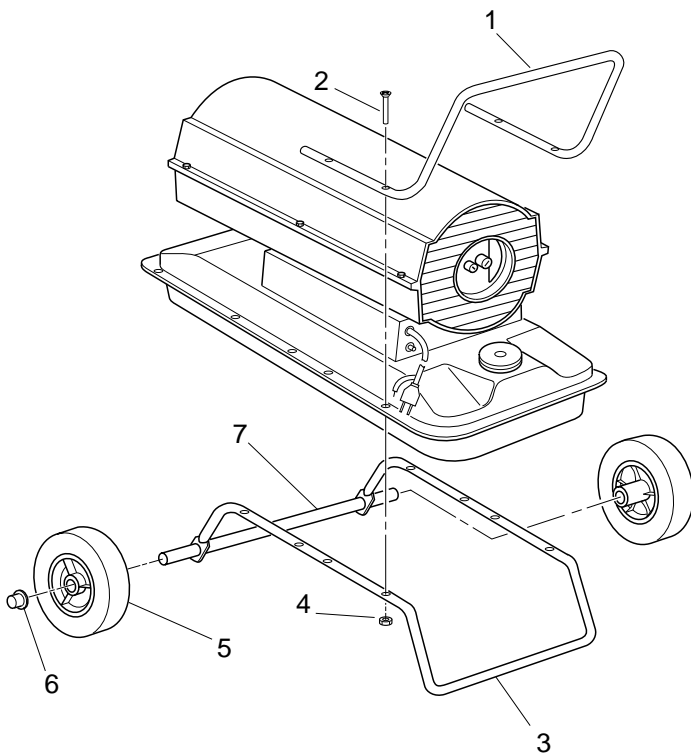

REM J150

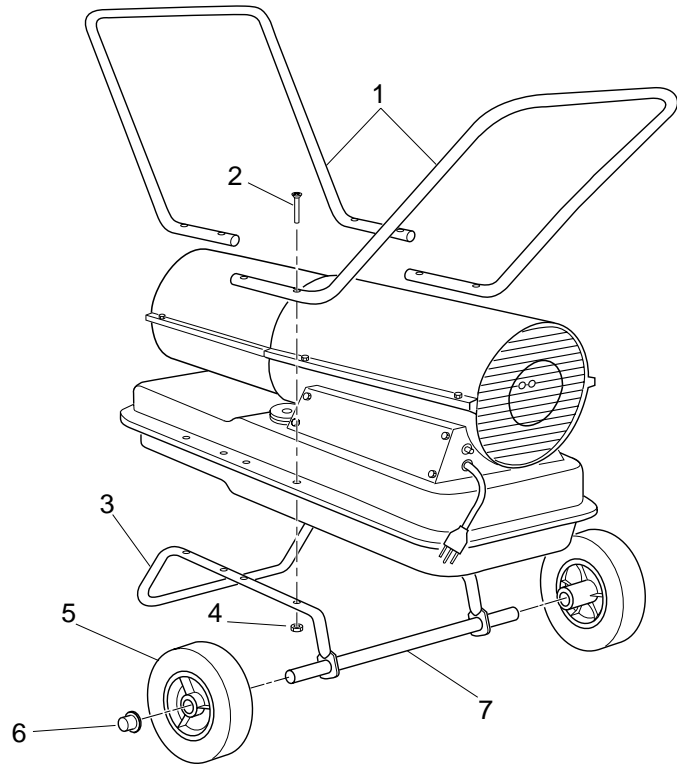

WIRING DIAGRAMS

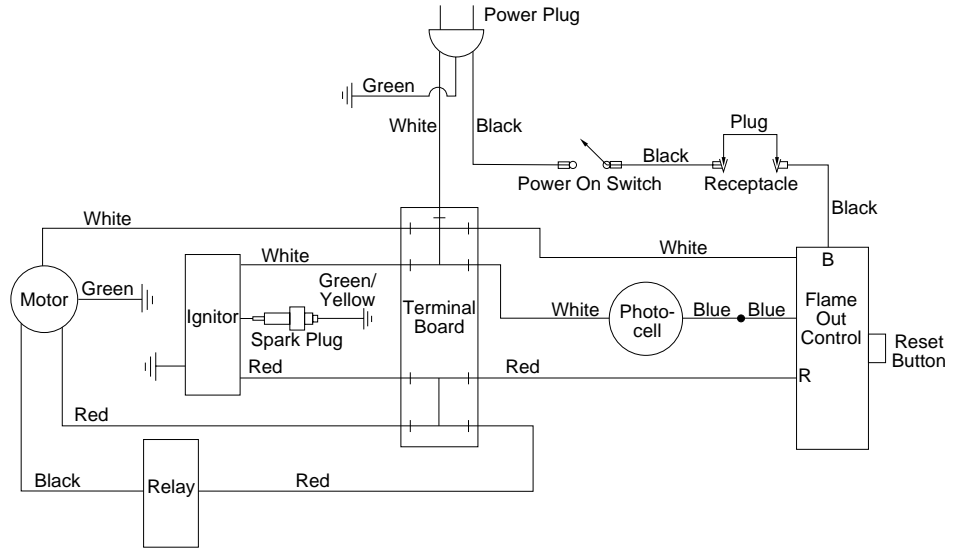

Figure 25 - Wiring Diagram (REMJ70)

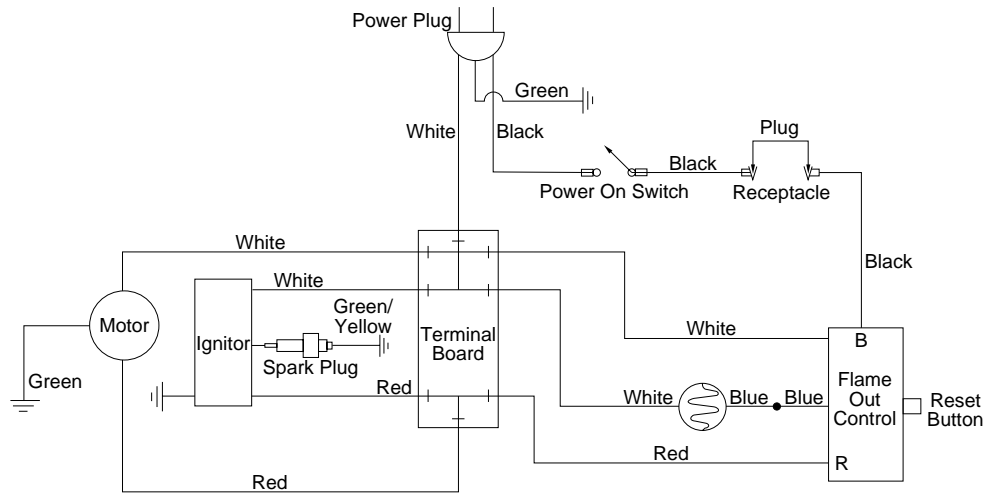
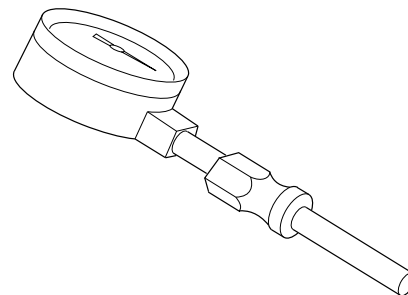

Figure 26 - Wiring Diagram (REMJ150)

ACCESSORY

Purchase accessory from your local dealer.



AIR GAUGE KIT - HA1180
For all models. Special tool to check pump pressure.

Printed in U.S.A.

102961-01
Rev. A
06/96

Free Manuals Download Website

<http://myh66.com>

<http://usermanuals.us>

<http://www.somanuals.com>

<http://www.4manuals.cc>

<http://www.manual-lib.com>

<http://www.404manual.com>

<http://www.luxmanual.com>

<http://aubethermostatmanual.com>

Golf course search by state

<http://golfingnear.com>

Email search by domain

<http://emailbydomain.com>

Auto manuals search

<http://auto.somanuals.com>

TV manuals search

<http://tv.somanuals.com>