

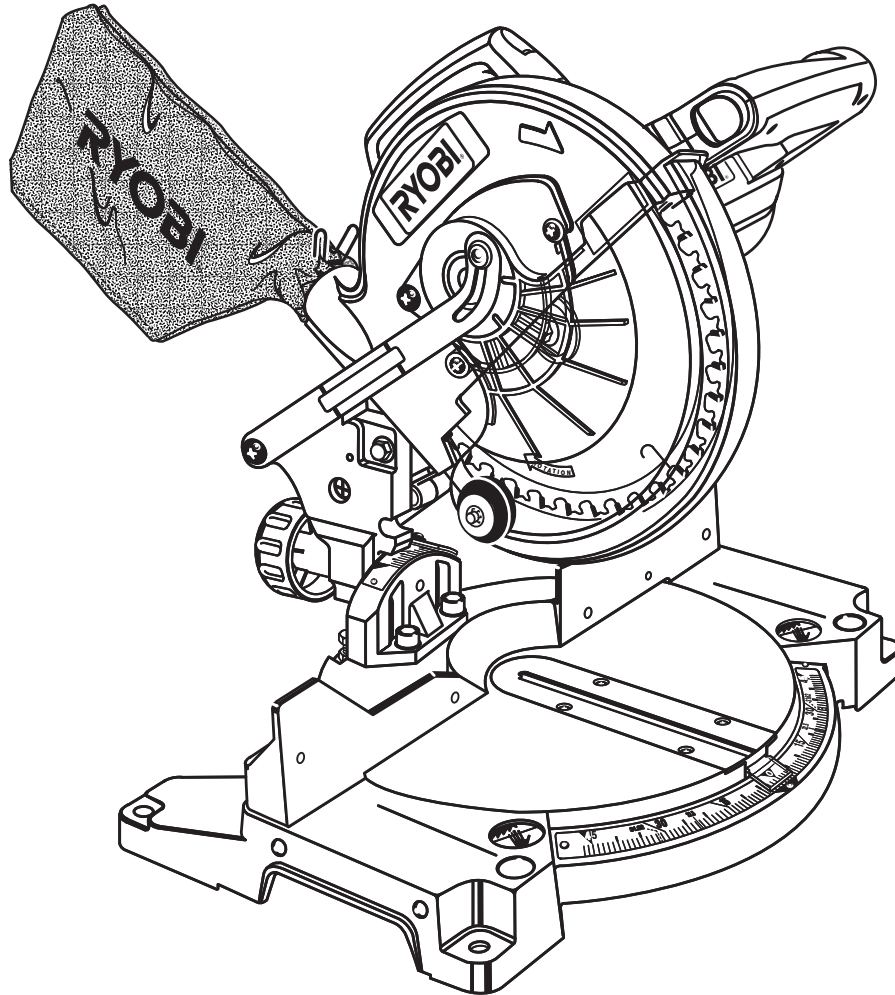

OPERATOR'S MANUAL

8-1/4 in., 18 Volt Cordless Compound Miter Saw P550



Your miter saw has been engineered and manufactured to Ryobi's high standard for dependability, ease of operation, and operator safety. When properly cared for, it will give you years of rugged, trouble-free performance.

⚠ WARNING: To reduce the risk of injury, the user must read and understand the operator's manual before using this product.

Thank you for buying a Ryobi product.

SAVE THIS MANUAL FOR FUTURE REFERENCE

TABLE OF CONTENTS

■ Introduction	2
■ General Safety Rules	3-4
■ Specific Safety Rules	4
■ Safety Rules for Charger	5
■ Symbols	6-7
■ Glossary of Terms	8
■ Features	9-11
■ Tools Needed	11
■ Loose Parts	12
■ Assembly	13-19
■ Operation	20-29
■ Adjustments	30
■ Maintenance	31
■ Parts Ordering / Service	32

INTRODUCTION

This tool has many features for making its use more pleasant and enjoyable. Safety, performance, and dependability have been given top priority in the design of this product making it easy to maintain and operate.

GENERAL SAFETY RULES

WARNING!

READ AND UNDERSTAND ALL INSTRUCTIONS. Failure to follow all instructions listed below, may result in electric shock, fire and/or serious personal injury.

SAVE THESE INSTRUCTIONS

WORK AREA

- **Keep your work area clean and well lit.** Cluttered benches and dark areas invite accidents.
- **Do not operate power tools in explosive atmospheres, such as in the presence of flammable liquids, gases, or dust.** Power tools create sparks which may ignite the dust or fumes.
- **Keep bystanders, children, and visitors away while operating a power tool.** Distractions can cause you to lose control.

ELECTRICAL SAFETY

- **A battery operated tool with integral batteries or a separate battery pack must be recharged only with the specified charger for the battery.** A charger that may be suitable for one type of battery may create a risk of fire when used with another battery.
- **Use battery operated tool only with specifically designated battery pack.** Use of any other batteries may create a risk of fire.
- **Use battery only with charger listed.**

MODEL	BATTERY PACK (P100)	CHARGER (P110)
P550	130255004	1423701, 140237023 or 140237021

- **Do not abuse the cord. Never use the cord to carry the charger. Keep cord away from heat, oil, sharp edges, or moving parts. Replace damaged cords immediately.** Damaged cords may create a fire.

PERSONAL SAFETY

- **Stay alert, watch what you are doing and use common sense when operating a power tool. Do not use tool while tired or under the influence of drugs, alcohol, or medication.** A moment of inattention while operating power tools may result in serious personal injury.
- **Dress properly. Do not wear loose clothing or jewelry. Contain long hair. Keep your hair, clothing, and gloves away from moving parts.** Loose clothes, jewelry, or long hair can be caught in moving parts.
- **Avoid accidental starting. Be sure switch is in the locked or off position before inserting battery pack.** Carrying tools with your finger on the switch or inserting the battery pack into a tool with the switch on invites accidents.
- **Remove adjusting keys or wrenches before turning the tool on.** A wrench or a key that is left attached to a rotating part of the tool may result in personal injury.

- **Do not overreach. Keep proper footing and balance at all times.** Proper footing and balance enable better control of the tool in unexpected situations.
- **Use safety equipment. Always wear eye protection.** Dust mask, non-skid safety shoes, hard hat, or hearing protection must be used for appropriate conditions.
- **Do not wear loose clothing or jewelry. Contain long hair.** Loose clothes, jewelry, or long hair can be drawn into air vents.
- **Do not use on a ladder or unstable support.** Stable footing on a solid surface enables better control of the tool in unexpected situations.

TOOL USE AND CARE

- **Use clamps or other practical way to secure and support the workpiece to a stable platform.** Holding the work by hand or against your body is unstable and may lead to loss of control.
- **Do not force tool. Use the correct tool for your application.** The correct tool will do the job better and safer at the rate for which it is designed.
- **Do not use tool if switch does not turn it on or off.** A tool that cannot be controlled with the switch is dangerous and must be repaired.
- **Disconnect battery pack from tool or place the switch in the locked or off position before making any adjustments, changing accessories, or storing the tool.** Such preventive safety measures reduce the risk of starting the tool accidentally.
- **Store idle tools out of reach of children and other untrained persons.** Tools are dangerous in the hands of untrained users.
- **When battery pack is not in use, keep it away from other metal objects like: paper clips, coins, keys, nails, screws, or other small metal objects that can make a connection from one terminal to another.** Shorting the battery terminals together may cause sparks, burns, or a fire.
- **Maintain tools with care. Keep cutting tools sharp and clean.** Properly maintained tools with sharp cutting edges are less likely to bind and are easier to control.
- **Check for misalignment or binding of moving parts, breakage of parts, and any other condition that may affect the tool's operation. If damaged, have the tool serviced before using.** Many accidents are caused by poorly maintained tools.
- **Use only accessories that are recommended by the manufacturer for your model.** Accessories that may be suitable for one tool may create a risk of injury when used on another tool.
- **Keep the tool and its handle dry, clean and free from oil and grease.** Always use a clean cloth when cleaning. Never use brake fluids, gasoline, petroleum-based products, or any strong solvents to clean your tool. Following this rule will reduce the risk of loss of control and deterioration of the enclosure plastic.

GENERAL SAFETY RULES

SERVICE

- **Tool service must be performed only by qualified repair personnel.** Service or maintenance performed by unqualified personnel may result in a risk of injury.
- **When servicing a tool, use only identical replacement parts. Follow instructions in the Maintenance section of this manual.** Use of unauthorized parts or failure to follow Maintenance Instructions may create a risk of shock or injury.

SPECIFIC SAFETY RULES

- **Hold tool by insulated gripping surfaces when performing an operation where the cutting tool may contact hidden wiring.** Contact with a “live” wire will also make exposed metal parts of the tool “live” and shock the operator.
- **Know your power tool. Read operator’s manual carefully. Learn its applications and limitations, as well as the specific potential hazards related to this tool.** Following this rule will reduce the risk of electric shock, fire, or serious injury.
- **Always wear safety glasses with side shields.** Everyday glasses have only impact resistant lenses. They are NOT safety glasses. Following this rule will reduce the risk of eye injury.
- **Protect your lungs. Wear a face or dust mask if the operation is dusty.** Following this rule will reduce the risk of serious personal injury.
- **Protect your hearing. Wear hearing protection during extended periods of operation.** Following this rule will reduce the risk of serious personal injury.
- **Battery tools do not have to be plugged into an electrical outlet; therefore, they are always in operating condition. Be aware of possible hazards when not using your battery tool or when changing accessories.** Following this rule will reduce the risk of electric shock, fire, or serious personal injury.
- **Do not place battery tools or their batteries near fire or heat.** This will reduce the risk of explosion and possibly injury.
- **Never use a battery that has been dropped or received a sharp blow.** A damaged battery is subject to explosion. Properly dispose of a dropped or damaged battery immediately.
- **Batteries vent hydrogen gas and can explode in the presence of a source of ignition, such as a pilot light.** To reduce the risk of serious personal injury, never use any cordless product in the presence of open flame. An exploded battery can propel debris and chemicals. If exposed, flush with water immediately.
- **Use this saw to cut wood, wood products and some plastics only. Do not cut metals, ceramics or masonry products.**
- **Do not charge battery tool in a damp or wet location.** Following this rule will reduce the risk of electric shock.
- **For best results, your battery tool should be charged in a location where the temperature is more than 50°F but less than 100°F. Do not store outside or in vehicles.**
- **Under extreme usage or temperature conditions, battery leakage may occur. If liquid comes in contact with your skin, wash immediately with soap and water, then neutralize with lemon juice or vinegar. If liquid gets into your eyes, flush them with clean water for at least 10 minutes, then seek immediate medical attention.** Following this rule will reduce the risk of serious personal injury.
- **THIS TOOL** should have the following markings:
 - a) Wear eye protection.
 - b) Keep hands out of path of saw blade
 - c) Do not operate saw without guards in place.
 - d) Do not perform any operation freehand.
 - e) Never reach around saw blade.
 - f) Turn off tool and wait for saw blade to stop before moving workpiece or changing settings.
 - g) Disconnect power (or unplug tool as applicable) before changing blade or servicing.
 - h) No load speed.
- **ALWAYS** carry the tool only by the carrying handle.
- **IF CARRYING THE BATTERY TOOL AT YOUR SIDE,** make sure it is not running and your finger is not on the switch. Avoid accidental starting.
- **SAVE THESE INSTRUCTIONS.** Refer to them frequently and use to instruct other users. If you loan someone this tool, loan them these instructions also.

SAFETY RULES FOR CHARGER

WARNING!

READ AND UNDERSTAND ALL INSTRUCTIONS.

Failure to follow all instructions listed below, may result in electric shock, fire and/or serious personal injury.

- **Before using battery charger**, read all instructions and cautionary markings in this manual, on battery charger, battery, and product using battery to prevent misuse of the products and possible injury or damage.

CAUTION:

To reduce the risk of electric shock or damage to the charger and battery, charge only nickel-cadmium rechargeable batteries as specifically designated on your charger. Other types of batteries may burst, causing personal injury or damage.

- **Do not use charger outdoors or expose to wet or damp conditions.** Water entering charger will increase the risk of electric shock.
- **Use of an attachment not recommended or sold by the battery charger manufacturer may result in a risk of fire, electric shock, or injury to persons.** Following this rule will reduce the risk of electric shock, fire, or serious personal injury.
- **Do not abuse cord or charger.** Never use the cord to carry the charger. Do not pull the charger cord rather than the plug when disconnecting from receptacle. Damage to the cord or charger could occur and create an electric shock hazard. Replace damaged cords immediately.
- **Make sure cord is located so that it will not be stepped on, tripped over, come in contact with sharp edges or moving parts or otherwise subjected to damage or stress.** This will reduce the risk of accidental falls, which could cause injury, and damage to the cord, which could result in electric shock.
- **Keep cord and charger from heat to prevent damage to housing or internal parts.**
- **Do not let gasoline, oils, petroleum-based products, etc. come in contact with plastic parts.** They contain chemicals that can damage, weaken, or destroy plastic.

WARNING:

Some dust created by power sanding, sawing, grinding, drilling, and other construction activities contains chemicals known to cause cancer, birth defects or other reproductive harm. Some examples of these chemicals are:

- lead from lead-based paints,
- crystalline silica from bricks and cement and other masonry products, and
- arsenic and chromium from chemically-treated lumber.

Your risk from these exposures varies, depending on how often you do this type of work. To reduce your exposure to these chemicals: work in a well ventilated area, and work with approved safety equipment, such as those dust masks that are specially designed to filter out microscopic particles.

- **An extension cord should not be used unless absolutely necessary.** Use of improper extension cord could result in a risk of fire and electric shock. If extension cord must be used, make sure:

- a. That pins on plug of extension cord are the same number, size and shape as those of plug on charger.
- b. That extension cord is properly wired and in good electrical condition; and
- c. That wire size is large enough for AC ampere rating of charger as specified below:











Cord Length (Feet)	25'	50'	100'
Cord Size (AWG)	16	16	16

NOTE: AWG = American Wire Gauge

- **Do not operate charger with a damaged cord or plug**, which could cause shorting and electric shock. If damaged, have the charger replaced by an authorized serviceman.
- **Do not operate charger if it has received a sharp blow, been dropped, or otherwise damaged in any way.** Take it to an authorized serviceman for electrical check to determine if the charger is in good working order.
- **Do not disassemble charger.** Take it to an authorized serviceman when service or repair is required. Incorrect reassembly may result in a risk of electric shock or fire.
- **Unplug charger from outlet before attempting any maintenance or cleaning to reduce the risk of electric shock.**
- **Disconnect charger from the power supply when not in use.** This will reduce the risk of electric shock or damage to the charger if metal items should fall into the opening. It also will help prevent damage to the charger during a power surge.
- **Risk of electric shock.** Do not touch uninsulated portion of output connector or uninsulated battery terminal.
- **Save these instructions.** Refer to them frequently and use them to instruct others who may use this tool. If you loan someone this tool, loan them these instructions also to prevent misuse of the product and possible injury.



SYMBOLS

Some of the following symbols may be used on this tool. Please study them and learn their meaning. Proper interpretation of these symbols will allow you to operate the tool better and safer.

SYMBOL	NAME	DESIGNATION/EXPLANATION
V	Volts	Voltage
A	Amperes	Current
Hz	Hertz	Frequency (cycles per second)
W	Watt	Power
min	Minutes	Time
~	Alternating Current	Type of current
==	Direct Current	Type or a characteristic of current
n_0	No Load Speed	Rotational speed, at no load
	Class II Construction	Double-insulated construction
.../min	Per Minute	Revolutions, strokes, surface speed, orbits etc., per minute
	Wet Conditions Alert	Do not expose to rain or use in damp locations.
	Read The Operator's Manual	To reduce the risk of injury, user must read and understand operator's manual before using this product.
	Eye Protection	Always wear safety goggles or safety glasses with side shields, or a full face shield when operating this product.
	Safety Alert	Precautions that involve your safety.
	No Hands Symbol	Failure to keep your hands away from the blade will result in serious personal injury.
	No Hands Symbol	Failure to keep your hands away from the blade will result in serious personal injury.
	No Hands Symbol	Failure to keep your hands away from the blade will result in serious personal injury.
	No Hands Symbol	Failure to keep your hands away from the blade will result in serious personal injury.
	Hot Surface	To reduce the risk of injury or damage, avoid contact with any hot surface.

SYMBOLS

The following signal words and meanings are intended to explain the levels of risk associated with this product.

SYMBOL	SIGNAL	MEANING
	DANGER:	Indicates an imminently hazardous situation, which, if not avoided, will result in death or serious injury.
	WARNING:	Indicates a potentially hazardous situation, which, if not avoided, could result in death or serious injury.
	CAUTION:	Indicates a potentially hazardous situation, which, if not avoided, may result in minor or moderate injury.
	CAUTION:	(Without Safety Alert Symbol) Indicates a situation that may result in property damage.

SERVICE

Servicing requires extreme care and knowledge and should be performed only by a qualified service technician. For service we suggest you return the product to your nearest **AUTHORIZED SERVICE CENTER** for repair. When servicing, use only identical replacement parts.

WARNING:

To avoid serious personal injury, do not attempt to use this product until you read thoroughly and understand completely the operator's manual. Save this operator's manual and review frequently for continuing safe operation and instructing others who may use this product.

WARNING:



The operation of any power tool can result in foreign objects being thrown into your eyes, which can result in severe eye damage. Before beginning power tool operation, always wear safety goggles or safety glasses with side shields, or a full face shield when needed. We recommend Wide Vision Safety Mask for use over eyeglasses or standard safety glasses with side shields. Always use eye protection which is marked to comply with ANSI Z87.1.

SAVE THESE INSTRUCTIONS

GLOSSARY OF TERMS

Anti-Kickback Pawls (radial arm and table saws)

A device which, when properly installed and maintained, is designed to stop the workpiece from being kicked back toward the front of the saw during a ripping operation.

Arbor

The shaft on which a blade or cutting tool is mounted.

Bevel Cut

A cutting operation made with the blade at any angle other than 90° to the table surface.

Chamfer

A cut removing a wedge from a block so the end (or part of the end) is angled rather than at 90°.

Compound Cut

A cross cut made with both a miter and a bevel angle.

Crosscut

A cutting or shaping operation made across the grain or the width of the workpiece.

Cutterhead (planers and jointer planers)

A rotating cutterhead with adjustable blades or knives. The blades or knives remove material from the workpiece.

Dado Cut

A non-through cut which produces a square-sided notch or trough in the workpiece (requires a special blade).

Featherboard

A device used to help control the workpiece by guiding it securely against the table or fence during any ripping operation.

FPM or SPM

Feet per minute (or strokes per minute), used in reference to blade movement.

Freehand

Performing a cut without the workpiece being guided by a fence, miter gauge, or other aids.

Gum

A sticky, sap-based residue from wood products.

Heel

Alignment of the blade to the fence.

Kerf

The material removed by the blade in a through cut or the slot produced by the blade in a non-through or partial cut.

Kickback

A hazard that can occur when the blade binds or stalls, throwing the workpiece back toward operator.

Leading End

The end of the workpiece pushed into the tool first.

Miter Cut

A cutting operation made with the workpiece at any angle to the blade other than 90°.

Non-Through Cuts

Any cutting operation where the blade does not extend completely through the thickness of the workpiece.

Push Blocks (for jointer planers)

Device used to feed the workpiece over the jointer planer cutterhead during any operation. This aid helps keep the operator's hands well away from the cutterhead.

Push Blocks and Push Sticks (for table saws)

Devices used to feed the workpiece through the saw blade during cutting operations. A push stick (not a push block) should be used for narrow ripping operations. These aids help keep the operator's hands well away from the blade.

Pilot Hole (drill presses)

A small hole drilled in a workpiece that serves as a guide for drilling large holes accurately.

Resaw

A cutting operation to reduce the thickness of the workpiece to make thinner pieces.

Resin

A sticky, sap-based substance that has hardened.

Revolutions Per Minute (RPM)

The number of turns completed by a spinning object in one minute.

Ripping or Rip Cut

A cutting operation along the length of the workpiece.

Riving Knife/Spreader/Splitter (table saws)

A metal piece, slightly thinner than the blade, which helps keep the kerf open and also helps to prevent kickback.

Saw Blade Path

The area over, under, behind, or in front of the blade. As it applies to the workpiece, that area which will be or has been cut by the blade.

Set

The distance that the tip of the saw blade tooth is bent (or set) outward from the face of the blade.

Snipe (planers)

Depression made at either end of a workpiece by cutter blades when the workpiece is not properly supported.

Through Sawing

Any cutting operation where the blade extends completely through the thickness of the workpiece.

Throw-Back

The throwing back of a workpiece usually caused by the workpiece being dropped into the blade or being placed inadvertently in contact with the blade.

Workpiece or Material

The item on which the operation is being done.

Worktable

Surface where the workpiece rests while performing a cutting, drilling, planing, or sanding operation.

FEATURES

PRODUCT SPECIFICATIONS

Blade Arbor	5/8 in.
Blade Diameter.....	8-1/4 in.
No Load Speed	2,000/min.
Charger Input	120 V, 60 Hz, AC only
Charger Rate	1 hour
Motor.....	18 Volt DC
Tool Weight	19 lbs.

Cutting Capacity with Miter at 0°/Bevel 0°:
5-1/2 in. (wide) x 2-1/16 in. (tall)

Maximum Cutting Capacity with Miter at 45°/Bevel 0°:
3-3/4 in. (wide) x 2-1/16 in. (tall)

Maximum Cutting Capacity with Miter at 0°/Bevel 45°:
5-1/2 in. (wide) x 1-1/2 in. (tall)

Maximum Cutting Capacity with Miter at 45°/Bevel 45°:
3-3/4 in. (wide) x 1-1/2 in. (tall)

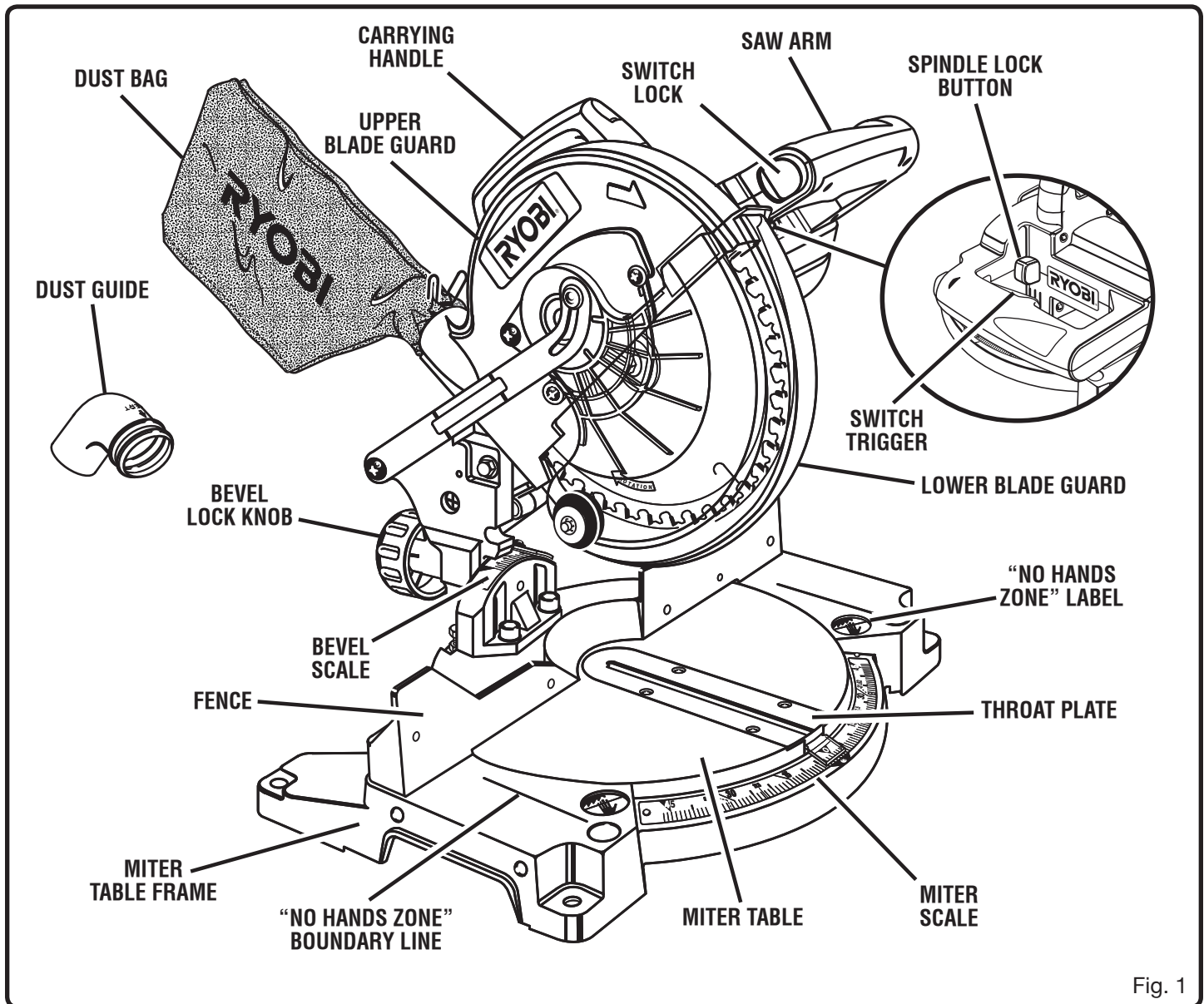

Fig. 1

KNOW YOUR COMPOUND MITER SAW

See Figure 1.

Before attempting to use this product, familiarize yourself with all operating features and safety rules.

8-1/4 in. BLADE

A 8-1/4 in. saw blade is included with the compound miter saw. It will cut materials up to 2-1/16 in. thick or 5-1/2 in. wide, depending upon the thickness of the material and the setting at which the cut is being made.

FEATURES

CARRYING HANDLE

See Figure 2.

For convenience when carrying or transporting the miter saw from one place to another, a carrying handle has been provided on top of the saw arm. To transport, turn off and unplug the saw, then lower the saw arm and lock it in the down position. Lock saw arm by depressing the lock pin.

MITER TABLE CLAMP

See Figure 3.

The miter table clamp securely locks the saw at desired miter angles.

SPINDLE LOCK BUTTON

See Figure 4.

A spindle lock button has been provided for locking the spindle which keeps the blade in the saw from rotating. Depress and hold the lock button while installing, changing, or removing blade.

SWITCH LOCK

See Figure 5.

The switch trigger is equipped with a switch lock to reduce the possibility of accidental starting.

To release switch lock feature:

- Depress the switch lock (1).
- While holding switch lock pushed in, depress the switch trigger (2).
- Release the switch lock (3).
- **NOTE:** The spring loaded lock will spring back into the switch lock position when switch trigger is released.

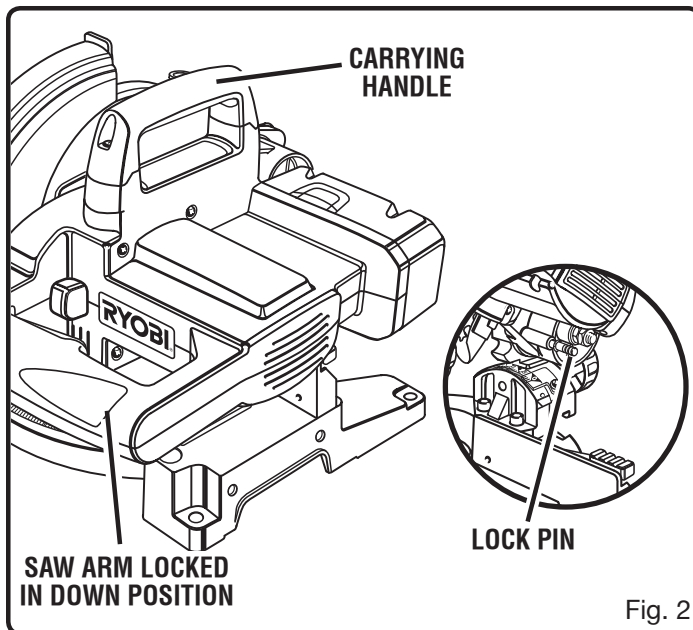

Fig. 2

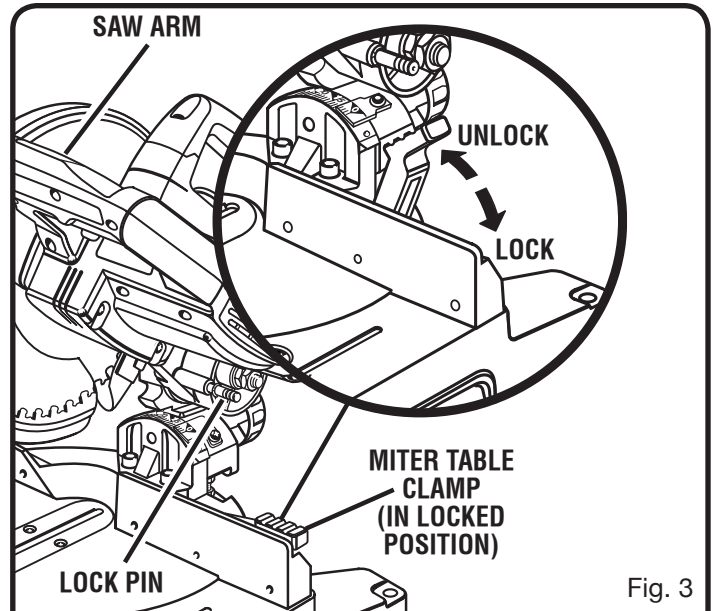

Fig. 3

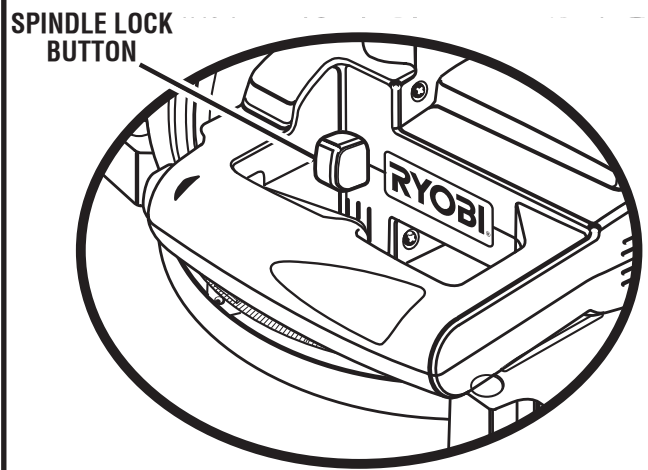

Fig. 4

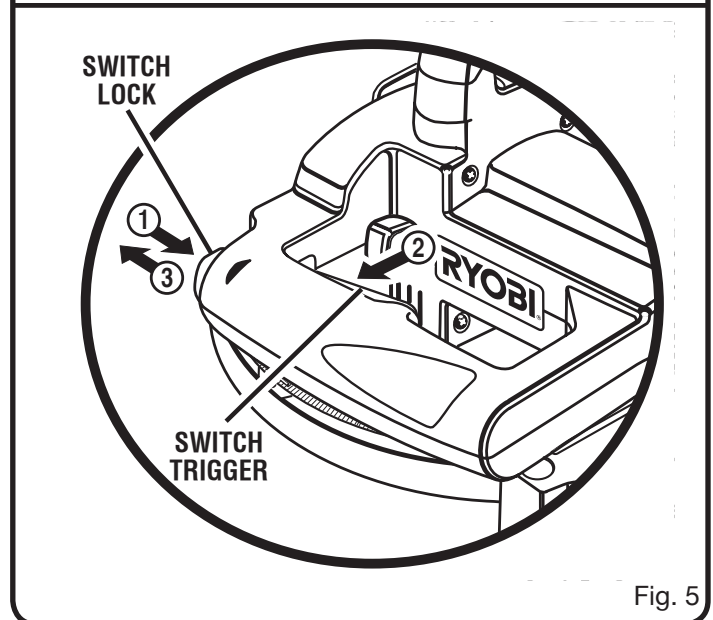

Fig. 5

FEATURES

SWITCH TRIGGER

See Figure 6.

To prevent unauthorized use of your compound miter saw, remove battery pack and lock the switch in the off position. To lock the switch, install a padlock through the hole in the switch trigger. A lock with a shackle up to 9/32 in. diameter may be used. When the lock is installed and locked, the switch is inoperable. Store the padlock key in another location.

POSITIVE STOPS ON MITER TABLE

Positive stops have been provided at 0°, 22-1/2°, 30°, and 45°. The 22-1/2°, 30° and 45° positive stops have been provided on both the left and right side of the miter table.

BEVEL LOCK KNOB

The bevel lock knob securely locks your compound miter saw at desired bevel angles. Positive stop adjustment screws have been provided on each side of the saw arm. These positive stop adjustment screws are for making fine adjustments at 0° and 45°.

FENCE

The fence on your compound miter saw has been provided to hold your workpiece securely against when making cuts.

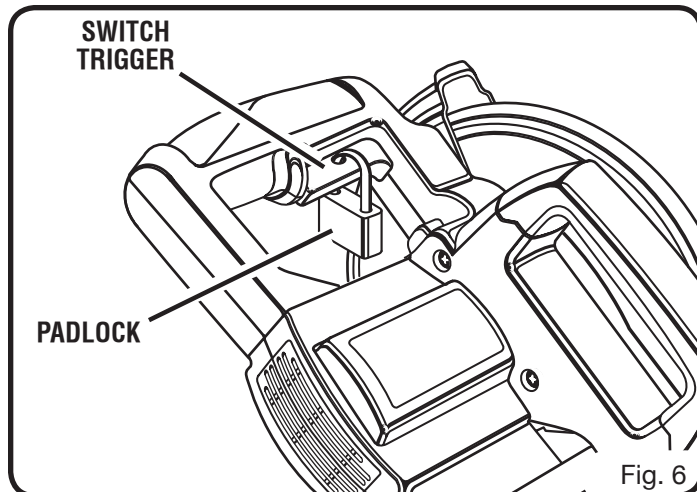

ELECTRIC BRAKE

An electric brake has been provided to quickly stop blade rotation after the switch is released.

SELF-RETRACTING LOWER BLADE GUARD

The lower blade guard is made of shock-resistant, see-through plastic that provides protection from each side of the blade. It retracts over the upper blade guard as the saw is lowered into the workpiece.

TOOLS NEEDED

The following tools are needed for making adjustments or installing the blade:

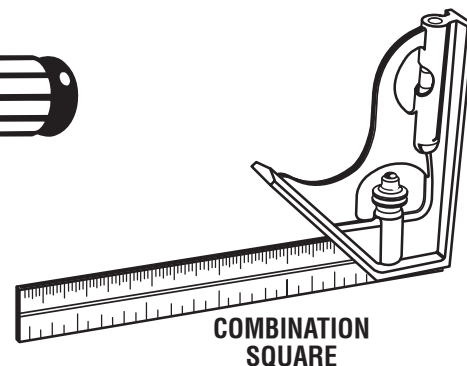
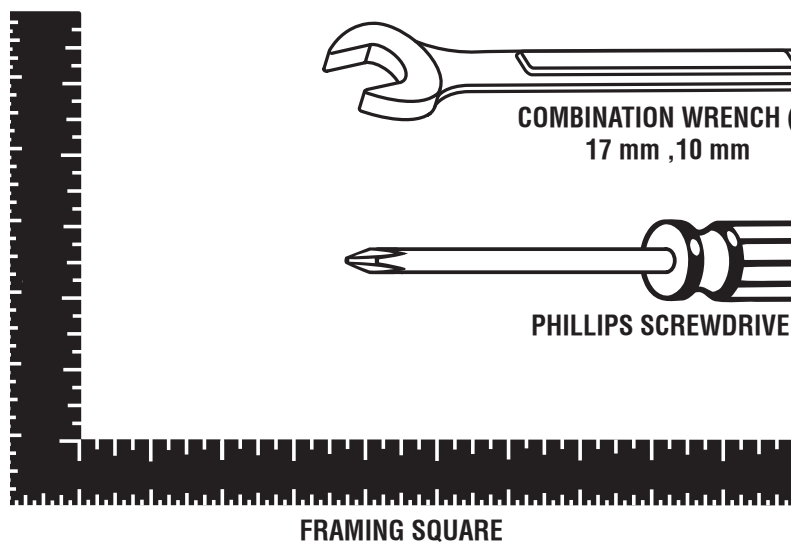

Fig. 7

LOOSE PARTS

The following items are included with the tool:

- 8-1/4 in. Carbide Tipped Saw Blade
- Dust Bag
- Dust Guide
- Blade Wrench
- Work Clamp
- Hex Key, 5 mm
- Hex Key, 6 mm
- Operator's Manual (Not Shown)

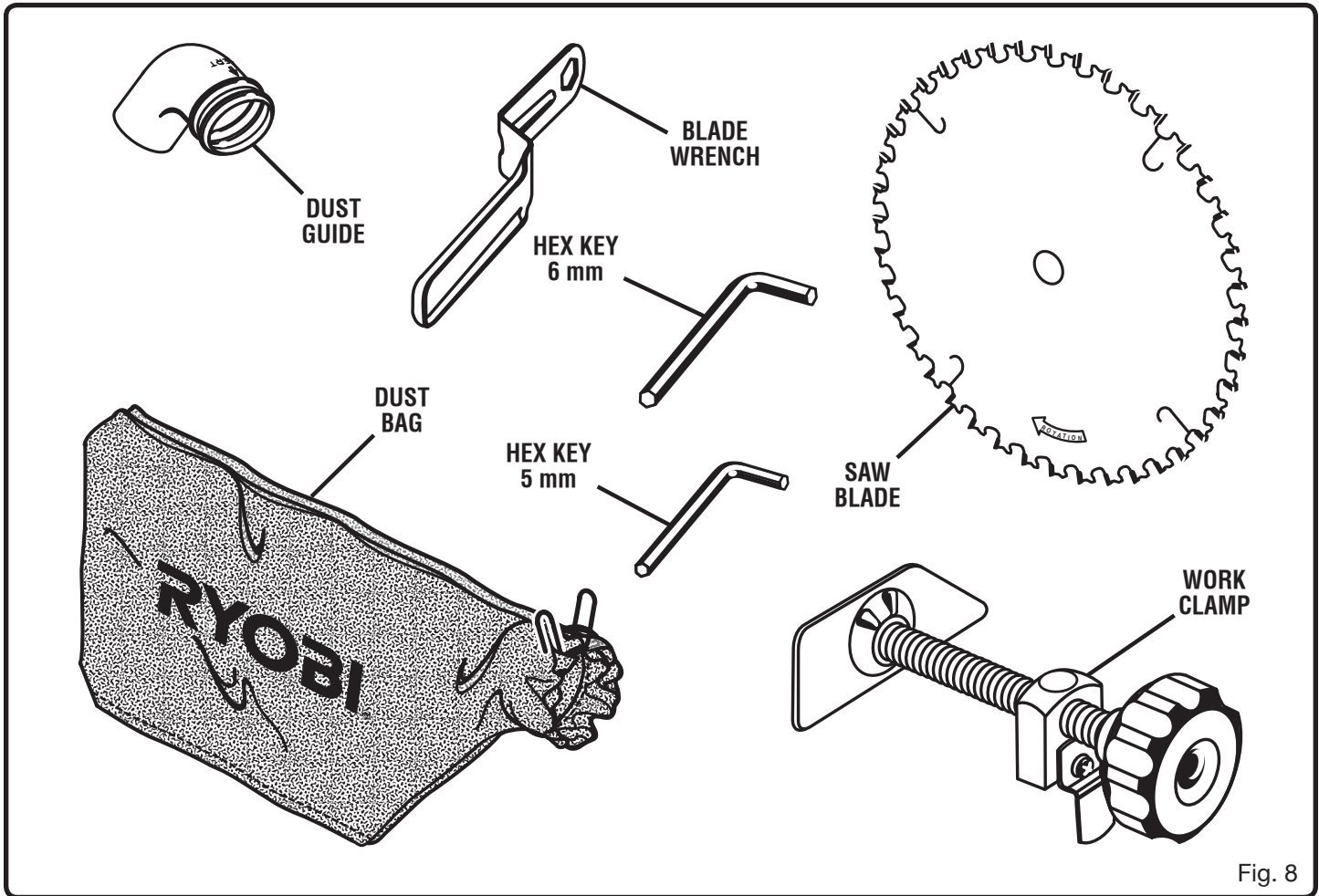

Fig. 8

⚠ WARNING:

The use of attachments or accessories not listed might be hazardous and could cause serious personal injury.

ASSEMBLY

UNPACKING

This product requires assembly.

- Carefully lift the saw from the carton by the carrying handle and the saw base, and place it on a level work surface.

NOTE: This tool is heavy. To avoid back injury, lift with your legs, not your back, and get help when needed.

- This saw has been shipped with the saw arm secured in the down position. To release the saw arm, push down on the top of the saw arm, cut the tie-wrap, and pull out on the lock pin.
- Lift the saw arm by the handle. Hand pressure should remain on the saw arm to prevent sudden rise upon release of the tie wrap.
- Inspect the tool carefully to make sure no breakage or damage occurred during shipping.
- Do not discard the packing material until you have carefully inspected and satisfactorily operated the tool.
- The saw is factory set for accurate cutting. After assembling it, check for accuracy. If shipping has influenced the settings, refer to specific procedures explained in this manual.
- If any parts are damaged or missing, please call 1-800-525-2579 for assistance.

WARNING:

If any parts are missing, do not operate this tool until the missing parts are replaced. Failure to do so could result in possible serious personal injury.

WARNING:

Do not attempt to modify this tool or create accessories not recommended for use with this tool. Any such alteration or modification is misuse and could result in a hazardous condition leading to possible serious personal injury.

WARNING:

To prevent accidental starting that could cause serious personal injury, always remove the battery pack from the tool when assembling parts.

MOUNTING HOLES

See Figure 9.

WARNING:

Always make sure the compound miter saw is securely mounted to a workbench or an approved workstand. Failure to heed this warning can result in serious personal injury.

The compound miter saw should be mounted to a firm supporting surface such as a workbench. Four bolt holes have been provided in the saw base for this purpose. Each of the four mounting holes should be bolted securely using 3/8 in. machine bolts, lock washers, and hex nuts (not included). Bolts should be of sufficient length to accommodate the saw base, lock washers, hex nuts, and the thickness of the workbench. Tighten all four bolts securely.

The hole pattern for mounting to a workbench is shown in figure 9. Carefully check the workbench after mounting to make sure that no movement can occur during use. If any tipping, sliding, or walking is noted, secure the workbench to the floor before operating.

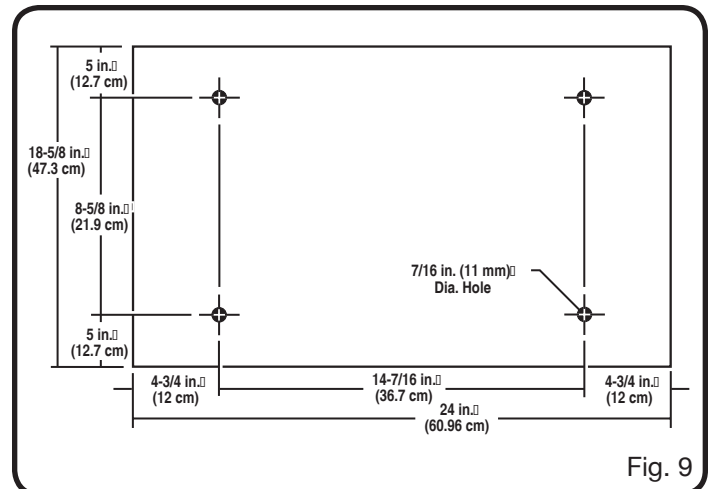

ASSEMBLY

DUST GUIDE

See Figure 10.

- Remove the battery pack from the tool.
- Place the dust guide (end marked **INSERT**) over the exhaust port in the upper blade guard. Turn the guide so the open end is facing down or towards the rear of the saw.

DUST BAG

See Figure 11.

Remove the battery pack from the tool. A dust bag is provided for use on this miter saw. It fits over the dust guide on the upper blade guard. To install, squeeze the two metal clips to open the mouth of the bag and slide it on to the dust guide. Release the clips. The metal ring in the bag should lock in between the grooves on the dust guide.

To remove the dust bag for emptying, simply reverse the above procedure.

WORK CLAMP

See Figure 12.

WARNING:

In some operations, the work clamp assembly may interfere with the operation of the blade guard assembly. Always make sure there is no interference with the blade guard prior to beginning any cutting operation to reduce the risk of serious personal injury.

The work clamp provides greater control by clamping the workpiece to the fence or the saw table. It also prevents the workpiece from creeping toward the blade. This is very helpful when cutting compound miters.

Depending on the cutting operation and the size of the workpiece, it may be necessary to use a C-clamp instead of the work clamp to secure the workpiece prior to making the cut.

To install the work clamp:

- Place the shaft of the work clamp in either hole on the saw table base.
- Rotate the knob on the work clamp to move it in or out as needed.

WARNING:

When using any clamp with a stop block, install the clamp on the same side as the stop block. This will eliminate the possibility of trapping the workpiece, resulting in the blade and workpiece kicking up. Failure to heed this warning can result in serious personal injury.

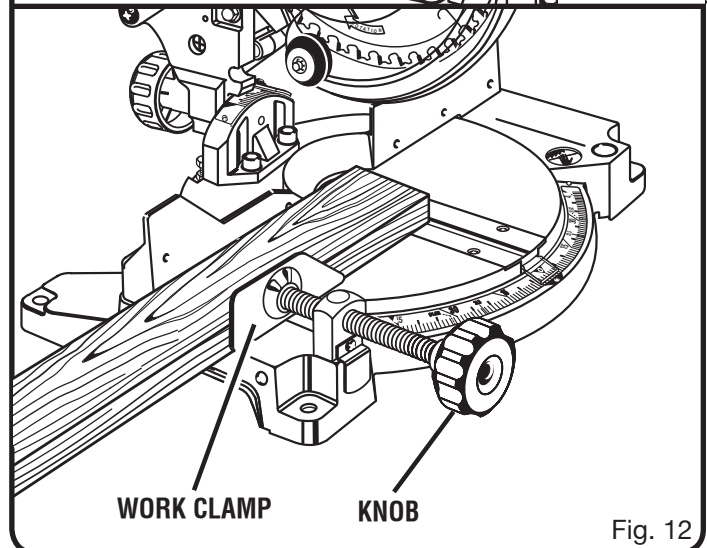
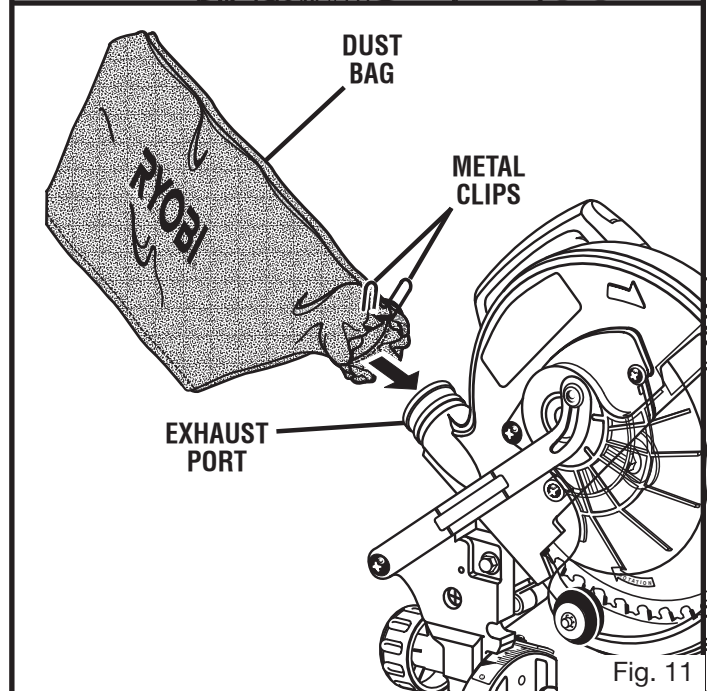
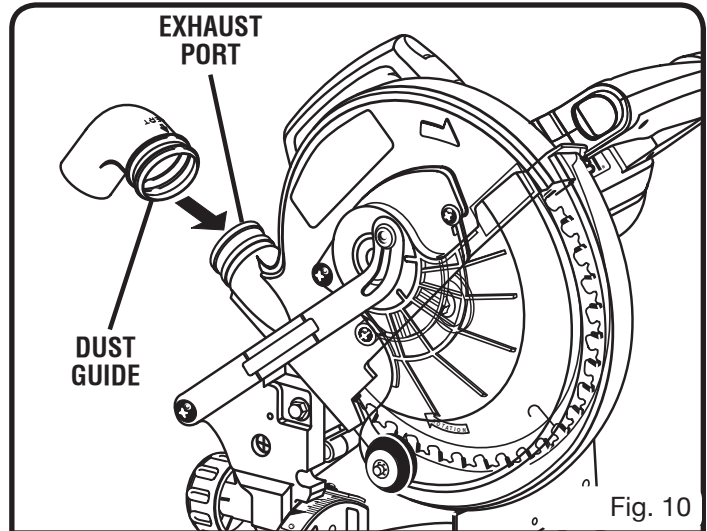

ASSEMBLY

TO INSTALL BLADE

See Figures 13 - 16.

⚠ WARNING:

A 8-1/4 in. blade is the maximum blade capacity of the saw. Never use a blade that is too thick to allow outer blade washer to engage with the flats on the spindle. Larger blades will come in contact with the blade guards, while thicker blades will prevent the blade bolt from securing the blade on the spindle. Either of these situations could result in a serious accident and can cause serious personal injury.

- Remove the battery pack from the tool.
- Push down on the saw arm and pull out the lock pin to release saw arm. Raise saw arm to its full raised position. Be cautious, saw arm is spring loaded to raise.
- Loosen the phillips screw on the blade bolt cover until blade bolt cover can be raised. See Figure 13.
- Gently raise the lower blade guard bracket, releasing lower blade guard from notch so that lower blade guard and blade bolt cover can be rotated up and back to expose the blade bolt. See Figure 14.
- Depress the spindle lock button and rotate the blade bolt until the spindle locks. See Figure 16.
- Using the blade wrench provided, loosen and remove the blade bolt.
NOTE: The blade bolt has left hand threads. Turn blade bolt clockwise to loosen.
- Remove outer blade washer. Do not remove inner blade washer.
- Wipe a drop of oil onto inner blade washer and outer blade washer where they contact the blade.

⚠ WARNING:

If inner blade washer has been removed, replace it before placing blade on spindle. Failure to do so could cause an accident since blade will not tighten properly.

- Fit saw blade inside lower blade guard and onto spindle. The blade teeth point downward at the front of saw as shown in figure 15.

⚠ CAUTION:

Always install the blade with the blade teeth and the arrow printed on the side of the blade pointing down at the front of the saw. The direction of blade rotation is also stamped with an arrow on the upper blade guard.

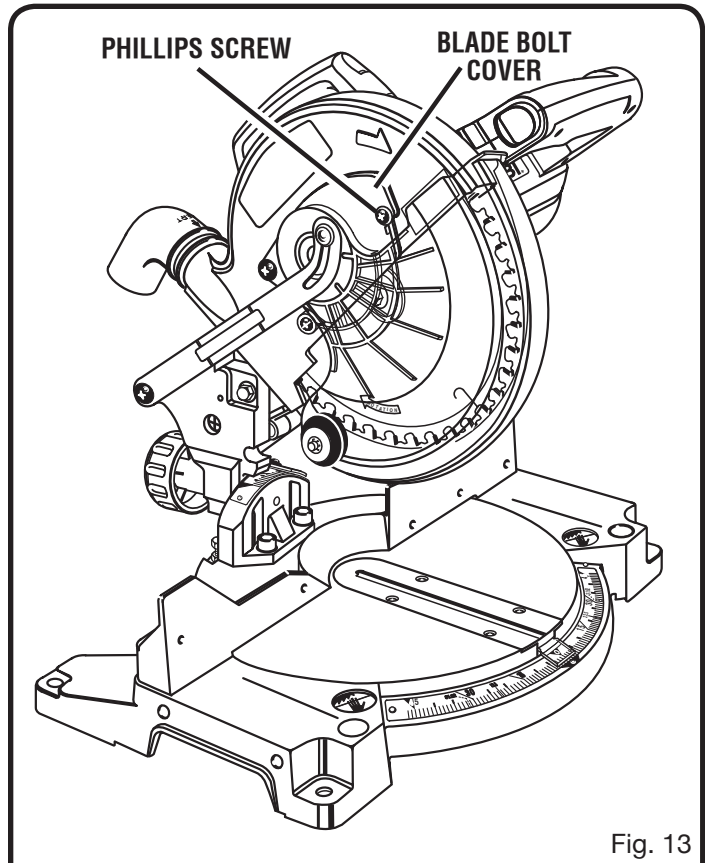

Fig. 13

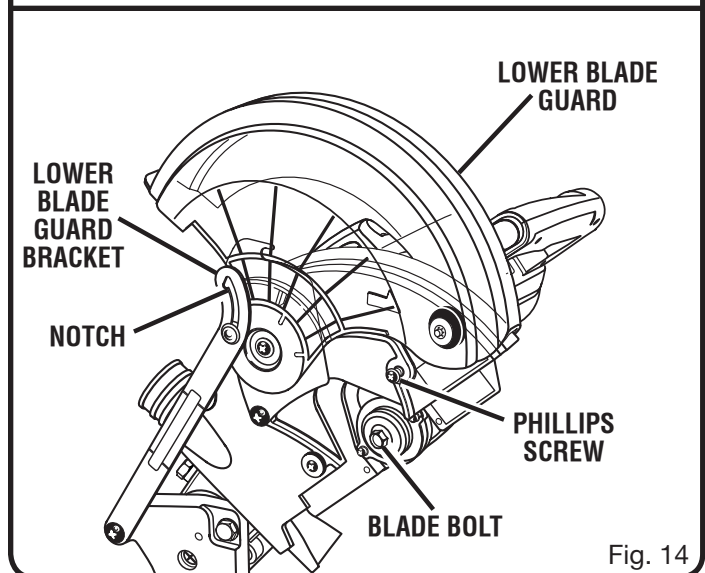

Fig. 14

ASSEMBLY

- Replace outer blade washer. The double “D” flats on the blade washers align with the flats on the spindle.
- Depress spindle lock button and replace blade bolt.
NOTE: The blade bolt has left hand threads. Turn blade bolt counterclockwise to tighten.
- Using the blade wrench provided, tighten blade bolt securely.
- Remove the blade wrench and store it in a safe place for future use.
- Replace the lower blade guard and blade bolt cover.
- Retighten phillips screw securing blade bolt cover. Tighten screw securely. *See Figure 15.*

⚠ WARNING:

To prevent damage to the spindle lock, always allow motor to come to a complete stop before engaging spindle lock. Make sure the spindle lock button is not engaged before attaching battery.

TO REMOVE BLADE

See Figures 13 - 16.

- Remove the battery pack from the tool.
- Loosen the phillips screw on the blade bolt cover until blade bolt cover can be raised. *See Figures 13 - 15.*
- Gently raise the lower blade guard bracket, releasing lower blade guard from notch so that lower blade guard and blade bolt cover can be rotated up and back to expose the blade bolt. *See Figure 14.*
- Depress the spindle lock button and rotate the blade bolt until the spindle locks. *See Figure 16.*
- Using the blade wrench provided, loosen and remove the blade bolt.
NOTE: The blade bolt has left hand threads. Turn blade bolt clockwise to loosen.
- Remove outer blade washer. The blade can now be removed.

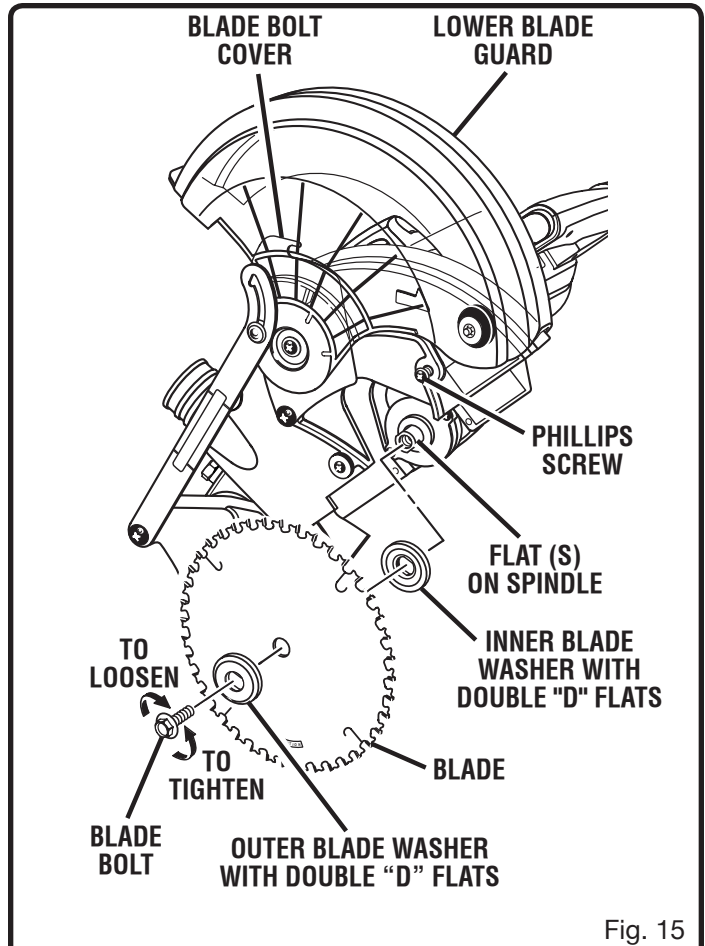

Fig. 15

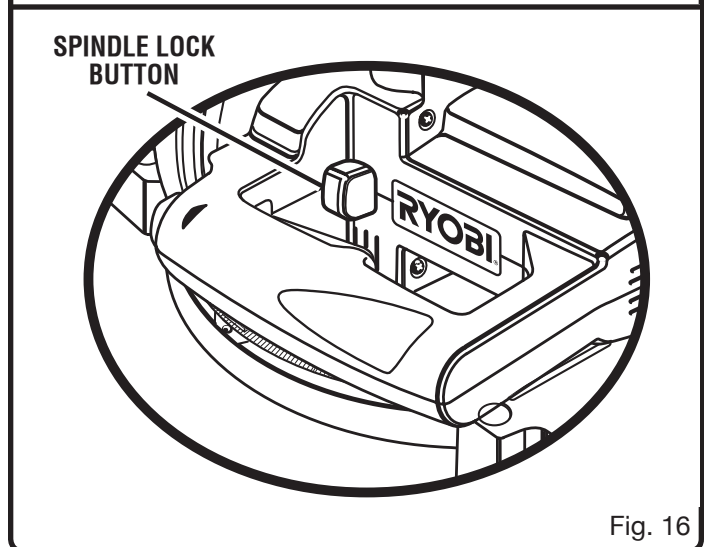

Fig. 16

ASSEMBLY

⚠ WARNING:

Make sure the spindle lock button is not engaged before reconnecting saw into power source. Never engage spindle lock button when blade is rotating.

NOTE: Many of the illustrations in this manual show only portions of the compound miter saw. This is intentional so that we can clearly show points being made in the illustrations. **Never operate the saw without all guards securely in place and in good operating condition.**

SQUARING THE MITER TABLE TO THE FENCE

See Figures 17 - 20.

- Remove the battery pack from the tool.
- Push down on the saw arm and pull out the lock pin to release the saw arm.
- Raise saw arm to its full raised position.
- Lift the miter table clamp.
- Rotate the miter table until the pointer is positioned at 0°.
- Push the miter table clamp back down.
- Lay a framing square flat on the miter table. Place one leg of the square against the fence. Place the other leg of the square beside the zero clearance throat plate in the miter table. The edge of the square and the zero clearance throat plate in the miter table should be parallel as shown in figure 17.
- If the edge of the framing square and the zero clearance throat plate in the miter table are not parallel as shown in figures 18 and 19, adjustments are needed.
- Using the 6 mm hex key, loosen the socket head screws securing the fence. See Figure 20. Adjust the fence left or right until the framing square and throat plate are parallel.
- Retighten the screws securely and recheck the fence-to-table alignment.

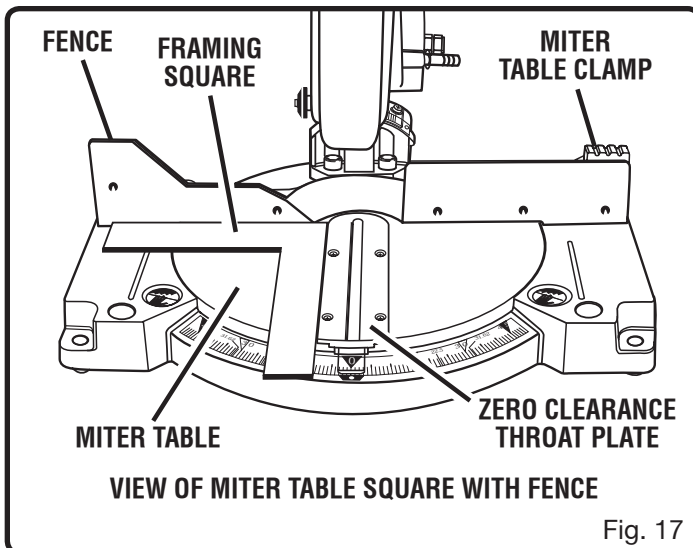

Fig. 17

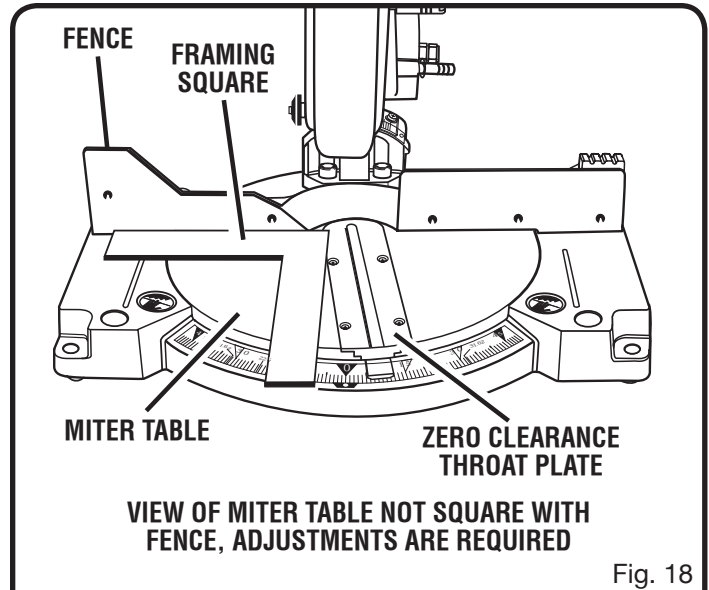

Fig. 18

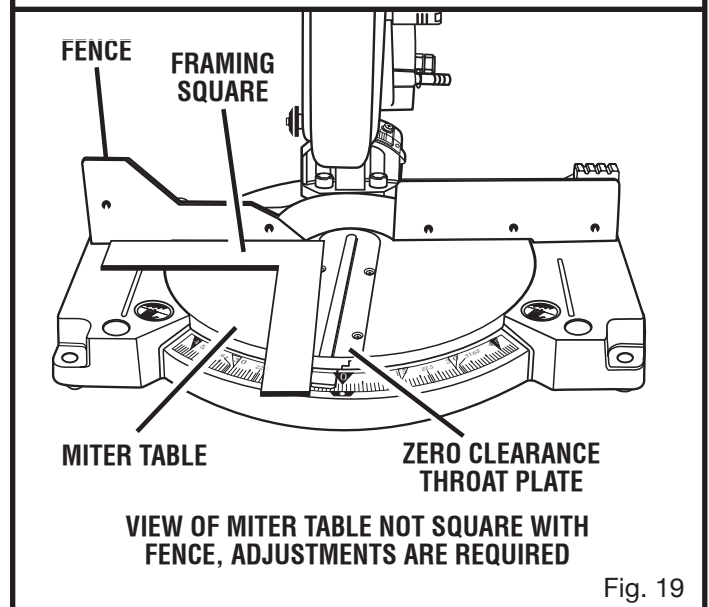

Fig. 19

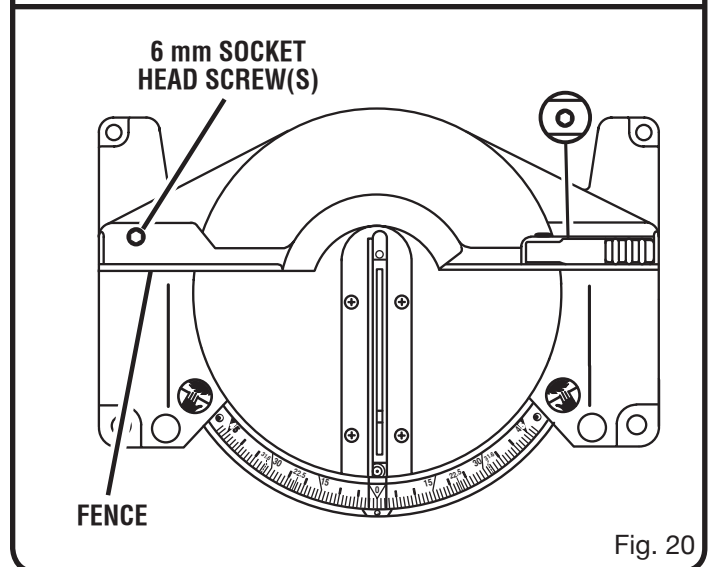

Fig. 20

ASSEMBLY

SQUARING THE SAW BLADE TO THE FENCE

See Figures 21 - 24.

- Remove the battery pack from the tool.
- Pull the saw arm all the way down and engage the lock pin to hold the saw arm in transport position.
- Lift the miter table clamp.
- Rotate the miter table until the pointer is positioned at 0°.
- Push the miter table clamp back down.
- Lay a framing square flat on the miter table. Place one leg of the square against the fence. Slide the other leg of the square against the flat part of the saw blade.

NOTE: Make sure that the square contacts the flat part of the saw blade, not the blade teeth.

- The edge of the square and the saw blade should be parallel as shown in figure 21.
- If the front or back edge of the saw blade angles away from the square as shown in figures 22 and 23, adjustments are needed.
- Using the 6 mm hex key provided, loosen the socket head screws that secure the mounting bracket to the miter table. See Figure 24.
- Rotate the mounting bracket left or right until the saw blade is parallel with the square.
- Retighten the screws securely and recheck the blade-to-fence alignment.

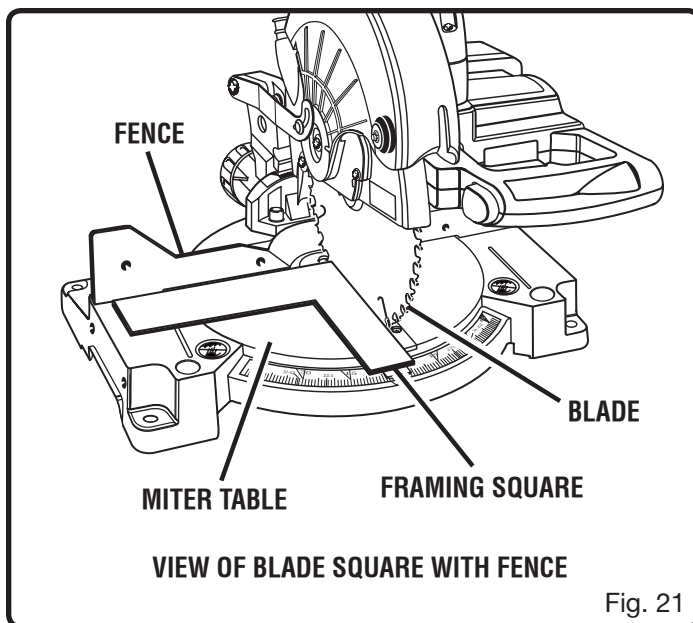

Fig. 21

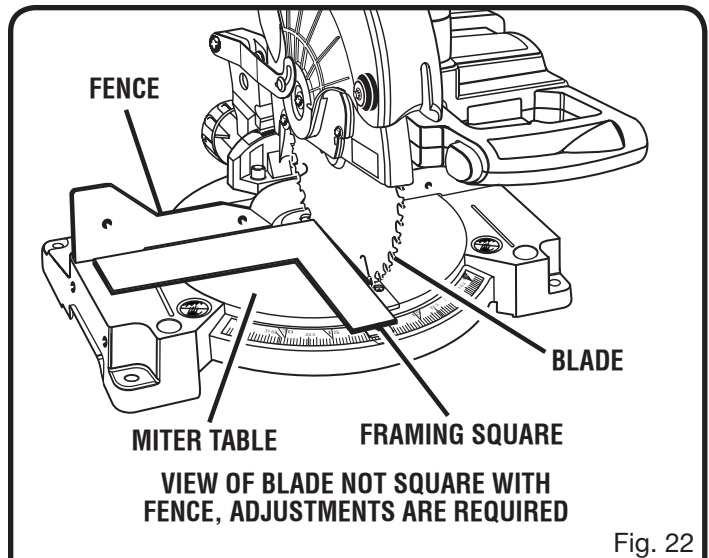

Fig. 22

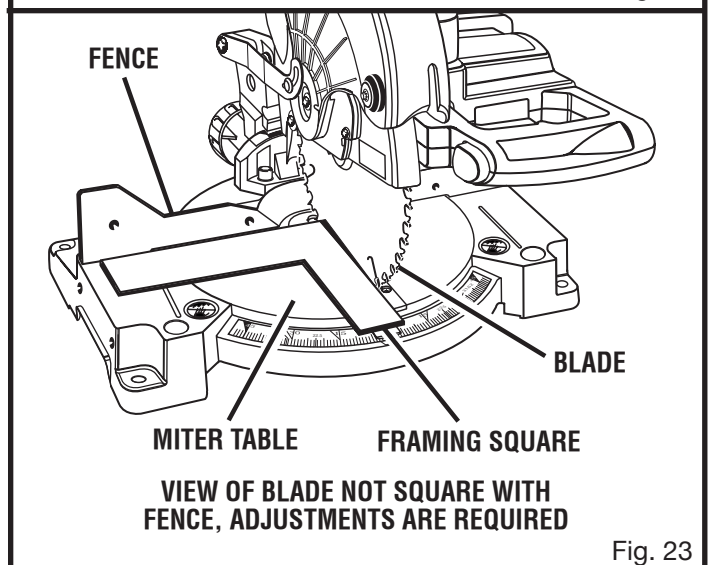

Fig. 23

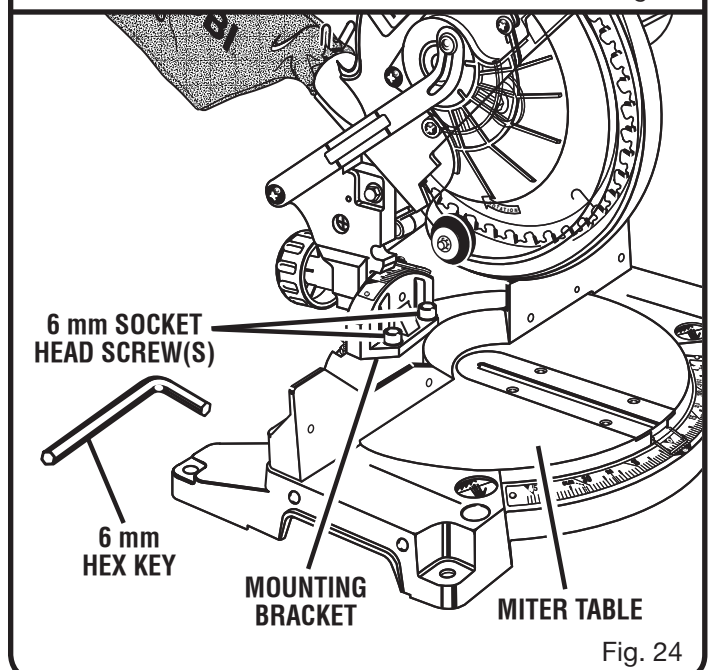

Fig. 24

ASSEMBLY

SQUARING THE BLADE TO THE MITER TABLE

See Figures 25 - 28.

- Remove the battery pack from the tool.
- Pull the saw arm all the way down and engage the lock pin to hold the saw arm in transport position.
- Lift the miter table clamp.
- Rotate the miter table until the pointer is positioned at 0°.
- Push the miter table clamp back down.
- Loosen bevel lock knob and set saw arm at 0° bevel (blade set 90° to miter table). Tighten bevel lock knob.
- Place a combination square against the miter table and the flat part of saw blade.

NOTE: Make sure that the square contacts the flat part of the saw blade, not the blade teeth.

- Rotate the blade by hand and check the blade-to-table alignment at several points.
- The edge of the square and the saw blade should be parallel as shown in figure 25.
- If the top or bottom of the saw blade angles away from the square as shown in figures 26 and 27, adjustments are needed.
- Using a 10 mm wrench or adjustable wrench, loosen the lock nut securing positive stop adjustment screw. Also loosen bevel lock knob.
- Adjust positive stop adjustment screw to bring saw blade into alignment with the square. See Figure 28.
- Retighten bevel lock knob. Next, retighten lock nut securing the positive stop adjustment screw. Recheck blade-to-table alignment.

NOTE: The above procedure can be used to check blade squareness of the saw blade to the miter table at both 0° and 45° angles.

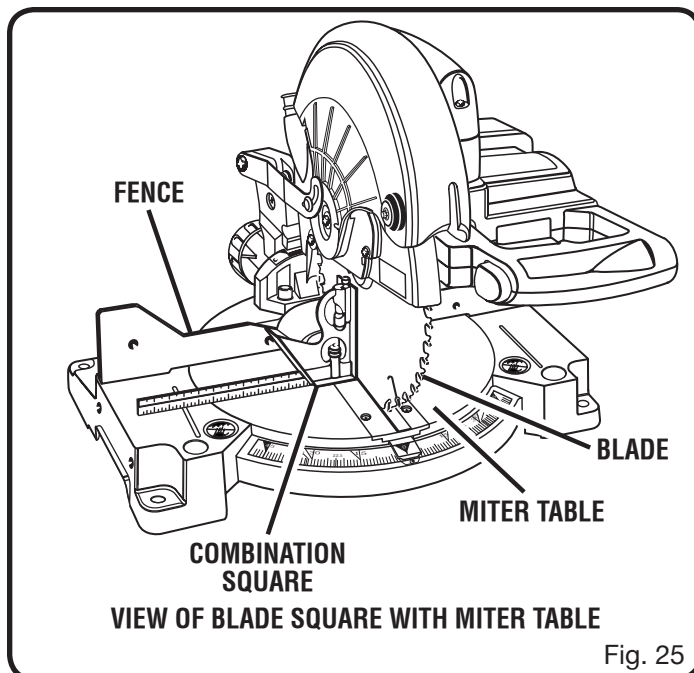

Fig. 25

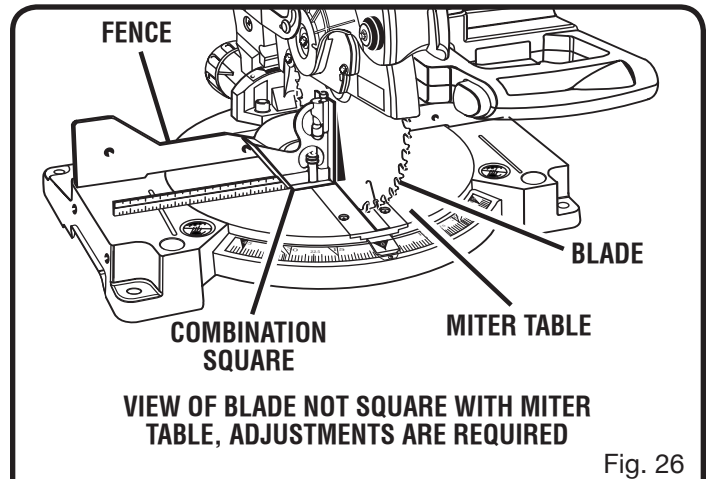

Fig. 26

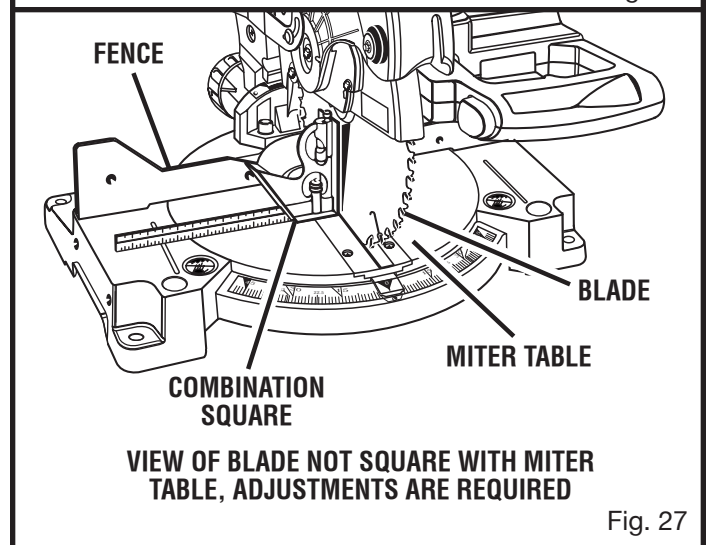

Fig. 27

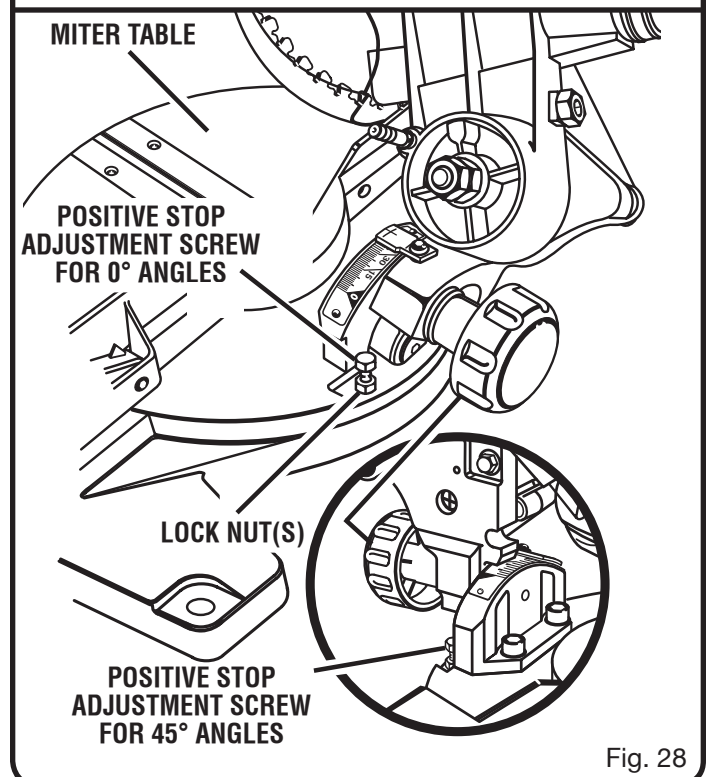

Fig. 28

OPERATION

WARNING:

Do not allow familiarity with tools to make you careless. Remember that a careless fraction of a second is sufficient to inflict serious injury.

WARNING:

Always wear safety goggles or safety glasses with side shields when operating tools. Failure to do so could result in objects being thrown into your eyes, resulting in possible serious injury.

WARNING:

Do not use any attachments or accessories not recommended by the manufacturer of this tool. The use of attachments or accessories not recommended can result in serious personal injury.

APPLICATIONS

You may use this tool for the following purposes:

- Crosscutting wood and plastic (Do not cut metals, ceramics or masonry products.)
- Crosscutting miters, joints, etc. for picture frames moldings, door casings, and fine joinery
- Bevel cutting and compound cutting

NOTE: The blade provided is fine for most wood cutting operations, but for fine joinery cuts or cutting plastic, use one of the accessory blades available from the nearest Ryobi retail store.

WARNING:

Before starting any cutting operation, clamp or bolt the compound miter saw to a workbench. Never operate the miter saw on the floor or in a crouched position. Failure to heed this warning can result in serious personal injury.

CAUTION:

If at any point during the charging process none of the LEDs are lit, remove the battery pack from the charger to avoid damaging the product. DO NOT insert another battery. Return the charger and battery to your nearest service center for service or replacement.

LED FUNCTIONS OF CHARGER

LED WILL BE ON TO INDICATE STATUS OF CHARGER AND BATTERY PACK:

- Red LED on = Fast charging mode.
- Green LED on = Fully charged and in maintenance charge mode.
- Green LED on = When battery pack is inserted into charger, indicates hot battery pack or that battery pack is out of normal temperature range.
- Yellow and Green LEDs on = Deeply discharged or defective battery pack.
- No LED on = Defective charger or battery pack.

CHARGING THE BATTERY PACK

The battery pack for this tool has been shipped in a low charge condition to prevent possible problems. Therefore, you should charge it until the green LED on the front of the charger comes on.

NOTE: Batteries will not reach full charge the first time they are charged. Allow several cycles (operation followed by recharging) for them to become fully charged.

CHARGING A COOL BATTERY PACK

If battery pack is within normal temperature range, the red LED on charger will come on.

NOTE: If the charger does not charge the battery pack under normal circumstances, return both the battery pack and charger to your nearest Ryobi Authorized Service Center for electrical check.

- Charge the battery pack only with the charger provided.
- Make sure the power supply is normal household voltage, **120 volts, 60 Hz, AC only.**
- Connect the charger to the power supply.
- Place the battery pack in the charger aligning raised rib on the battery pack with the groove in the charger.
- Press down on the battery pack to be sure contacts on the battery pack engage properly with contacts in the charger.
- Normally the red LED on charger will come on. This indicates the charger is in fast charging mode.
- Red LED should remain on for approximately 1 hour then the green LED will come on. Green LED on indicates battery pack is fully charged and charger is in maintenance charge mode.

NOTE: The green LED will remain on until the battery pack is removed from the charger or charger is disconnected from the power supply.

- If both yellow and green LEDs come on, this indicates a deeply discharged or defective battery pack. Allow the battery pack to remain in the charger for 15 to 30 minutes. When the battery pack reaches normal voltage range, the red LED should come on. If the

OPERATION

red LED does not come on after 30 minutes, this may indicate a defective battery pack and should be replaced.

- After normal usage, a minimum of 1 hour of charging time is required to fully recharge battery pack.
- The battery pack will become slightly warm to the touch while charging. This is normal and does not indicate a problem.
- Do not place the charger and battery pack in an area of extreme heat or cold. They will work best at normal room temperature.

NOTE: The charger and battery pack should be placed in a location where the temperature is more than 50°F but less than 100°F.

- When batteries become fully charged, unplug the charger from power supply and remove the battery pack.

CHARGING A HOT BATTERY PACK

When using the tool continuously, the batteries in the battery pack will become hot. You should let a hot battery pack cool down for approximately 30 minutes before attempting to recharge. When the battery pack becomes discharged and is hot, this will cause the green LED to come on instead of the red LED. After 30 minutes, reinsert the battery pack in the charger. If the green LED continues to remain on, return battery pack to your nearest Ryobi Authorized Service Center for checking or replacing.

NOTE: This situation only occurs when continuous use of the tool causes the batteries to become hot. It does not occur under normal circumstances. Refer to “**CHARGING A COOL BATTERY PACK**” for normal recharging of batteries. If the charger does not charge your battery pack under normal circumstances, return both the battery pack and charger to your nearest Ryobi Authorized Service Center for electrical check.

After all parts have been assembled properly, the battery pack can now be attached to tool.

TO INSTALL BATTERY PACK

See Figure 31.

- Place battery pack in the saw. Align raised rib on battery pack with groove inside saw.
- Make sure the latches on each side of the battery pack snap in place and that the battery pack is secured in the tool before beginning operation.

CAUTION:

When placing battery pack in the saw, be sure raised rib on battery pack aligns with groove inside saw and latches snap into place properly. Improper assembly of battery pack can cause damage to internal components.

TO REMOVE BATTERY PACK

See Figure 31.

- Locate latches on each side of the battery pack. Depress the latches to release the battery pack from the tool.
- Remove the battery pack from the tool.

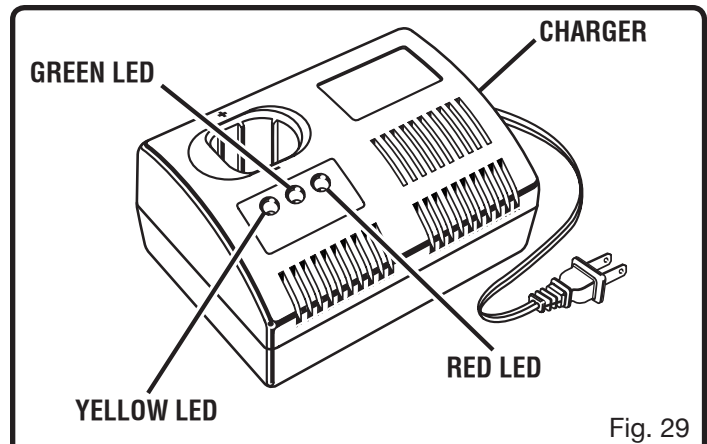

Fig. 29

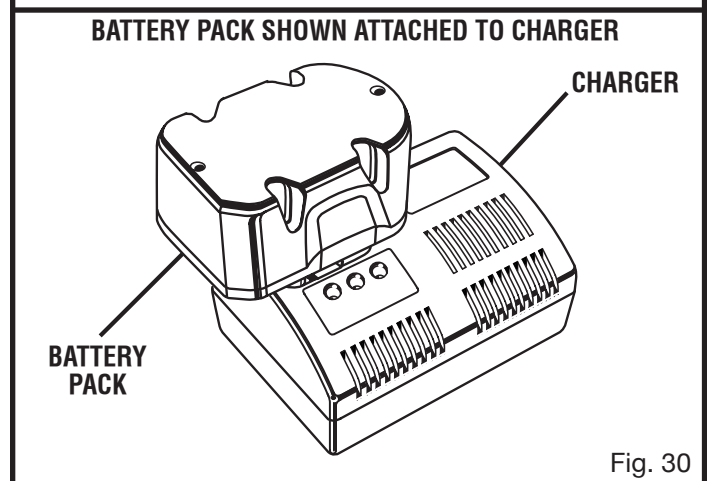

Fig. 30

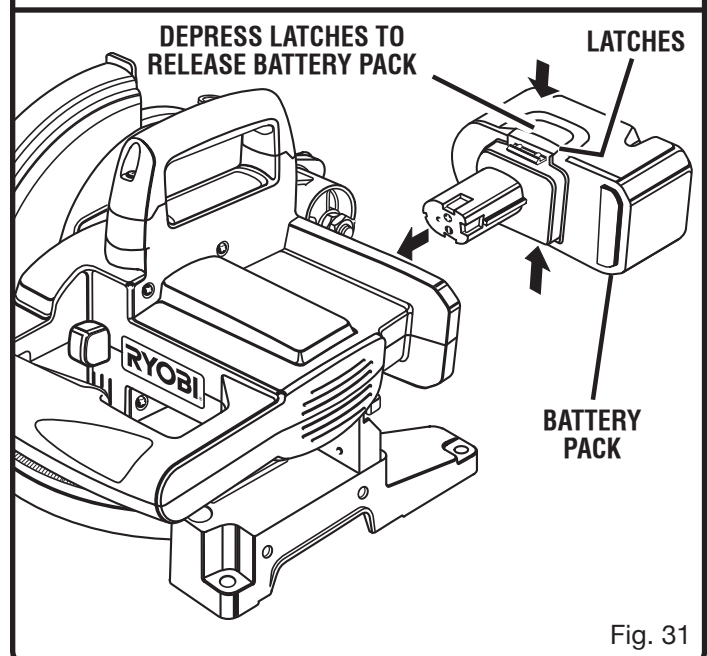

Fig. 31

OPERATION

CUTTING WITH YOUR COMPOUND MITER SAW

⚠ WARNING:

When using a work clamp or C-clamp to secure your workpiece, clamp workpiece on one side of the blade only. The workpiece must remain free on one side of the blade to prevent the blade from binding in workpiece. The workpiece binding the blade will cause motor stalling and kickback. This situation could cause an accident resulting in possible serious personal injury.

⚠ WARNING:

To avoid serious personal injury, always push the miter table clamp back down before making a cut. Failure to do so could result in movement of the miter table while making a cut.

⚠ WARNING:

To avoid serious personal injury, keep hands outside the no hands zone; at least 3 in. from blade. Never perform any cutting operation freehand (without holding workpiece against the fence). The blade could grab the workpiece if it slips or twists.

TO CUT SMALL MOLDING AND TRIM

See Figures 32 - 33.

When making compound or 90° miter cut on small molding or trim, it is necessary to install an auxiliary fence. The auxiliary fence will hold small workpieces in place during the cutting operation.

NOTE: Do not make a bevel cut through the auxiliary fence unless you anticipate making compound cuts.

To make an auxiliary fence:

- Using a piece of wood 1-1/2 in. thick, 2 in. wide, and 7-1/2 in. long, place the wood on the miter table against the left side miter fence. The left end of the wood should be even with the left end of the fence.
- Secure the wood to the miter fence using flat head/drywall screws. From the back of the saw, attach the screws through the holes in the miter fence and into the wood.
- Install a fully charged battery to the miter saw.
- Lift the miter table clamp and rotate the miter table until the pointer aligns with the 45° left mark on the miter scale.
- Push the miter table clamp down to lock.

- Grasp the saw handle firmly, depress the switch lock, then squeeze the switch trigger. Allow several seconds for the blade to reach maximum speed.
- Slowly lower the blade into and through the auxiliary fence.
- Release the switch trigger and allow the blade to stop rotating before raising the blade.

Repeat the above steps for the right side auxiliary fence making a 45° right miter cut.

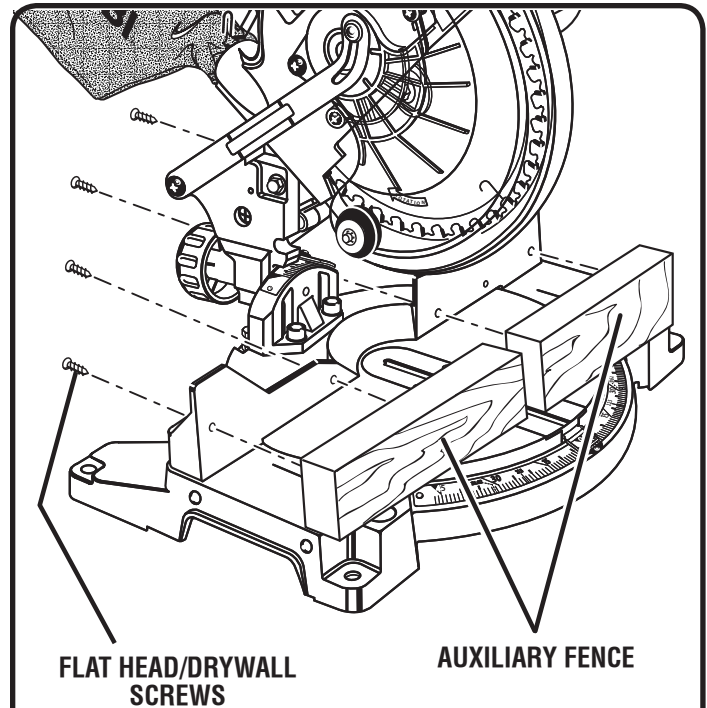

Fig. 32

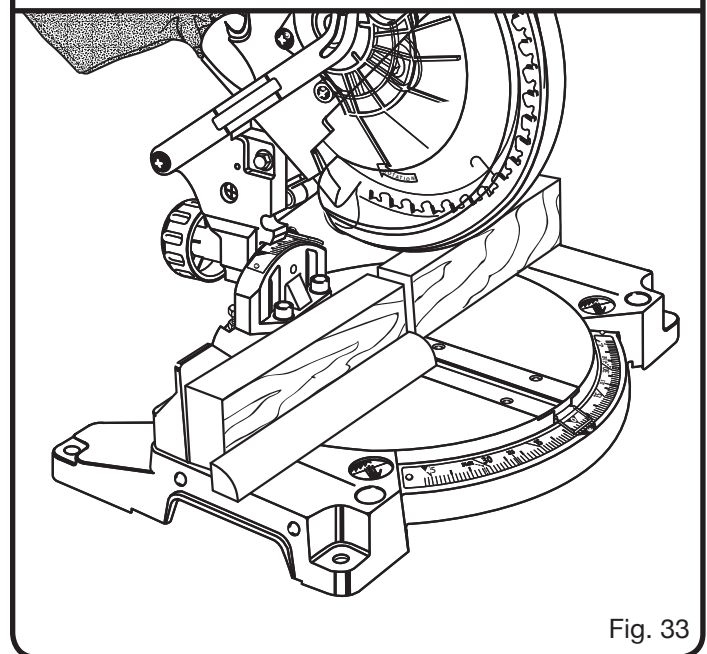

Fig. 33

OPERATION

TO CROSSCUT

See Figure 34.

A crosscut is made by cutting across the grain of the workpiece. A straight crosscut is made with the miter table set at the 0° position. Miter crosscuts are made with the miter table set at some angle other than zero.

- Pull out the lock pin and lift saw arm to its full height.
- Lift the miter table clamp.
- Rotate the miter table until the pointer aligns with the desired angle on the miter scale.
- Push the miter table clamp down to lock.

NOTE: You can quickly locate 0°, 22-1/2° left or right, 30° left or right, and 45° left or right by releasing the lock plate as you rotate the control arm. The lock plate will seat itself in one of the positive stop notches, located in the miter table frame.

- Place the workpiece flat on the miter table with one edge securely against the fence. If the board is warped, place the convex side against the fence. If the concave edge of a board is placed against the fence, the board could collapse on the blade at the end of the cut, jamming the blade.
- When cutting long pieces of lumber or molding, support the opposite end of the stock with a roller stand or with a work surface level with the saw table.
- Align cutting line on workpiece with edge of saw blade.
- Grasp the stock firmly with one hand and secure it against the fence. Use the optional work clamp or a C-clamp to secure the workpiece when possible.
- Before turning on the saw, perform a dry run of the cutting operation just to make sure that no problems will occur when the cut is made.
- Grasp the saw handle firmly, depress the switch lock, then squeeze the switch trigger. Allow several seconds for the blade to reach maximum speed.
- Slowly lower the blade into and through the workpiece.
- Release the switch trigger and allow the blade to stop rotating before raising the blade out of workpiece. Wait until the electric brake stops blade from turning before removing the workpiece from the miter table.

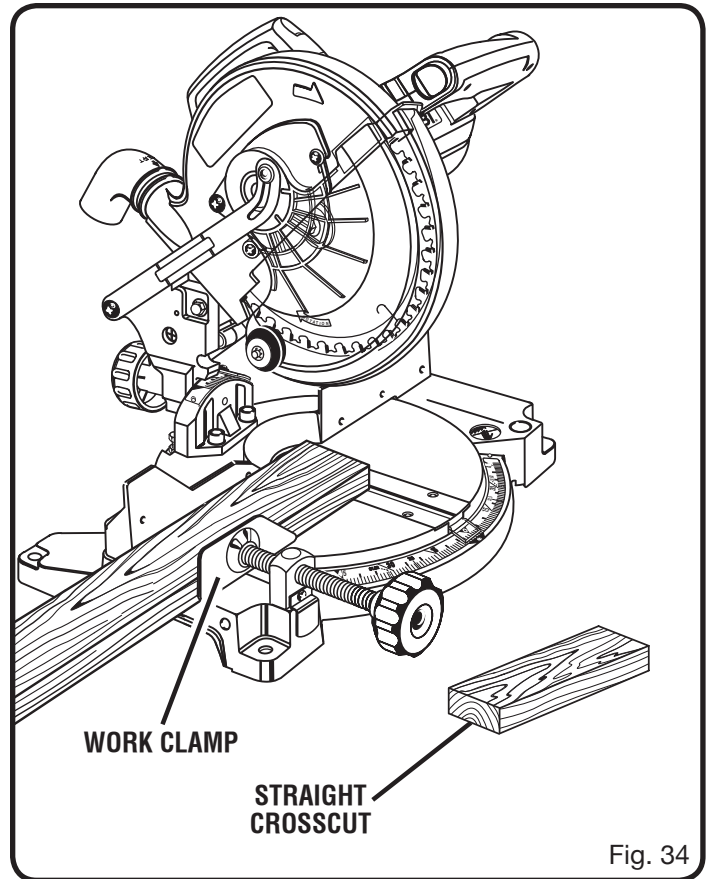

Fig. 34

OPERATION

TO BEVEL CUT

See Figures 35 - 36.

A bevel cut is made by cutting across the grain of the workpiece with the blade angled to the workpiece. A straight bevel cut is made with the miter table set at the zero degree position and the blade set at an angle between 0° and 45°.

- Pull out the lock pin and lift saw arm to its full height.
- Lift the miter table clamp.
- Rotate the miter table until the pointer aligns with zero on the miter scale.
- Push the miter table clamp down to lock.

NOTE: You can quickly locate zero on the scale. The miter table can be seated in one of the built-in positive stop notches located in the miter table frame.

- Loosen the bevel lock knob and move the saw arm to the left to the desired bevel angle.
- Bevel angles can be set from 0° to 45°.
- Align the indicator point with the desired angle.
- Once the saw arm has been set at the desired angle, securely tighten the bevel lock knob.
- Place the workpiece flat on the miter table with one edge securely against the fence. If the board is warped, place the convex side against the fence. If the concave edge of a board is placed against the fence, the board could collapse on the blade at the end of the cut, jamming the blade.
- When cutting long pieces of lumber or molding, support the overhanging end(s) of the stock with a roller stand or with a work surface level with the saw table.
- Align the cutting line on the workpiece with the edge of saw blade.
- Grasp the stock firmly with one hand and secure it against the fence. Use the work clamp or a C-clamp to secure the workpiece when possible.
- Before turning on the saw, perform a dry run of the cutting operation just to make sure that no problems will occur when the cut is made.
- Grasp the saw handle firmly, depress the switch lock, then squeeze the switch trigger. Allow several seconds for the blade to reach maximum speed.
- Slowly lower the blade into and through the workpiece.
- Release the switch trigger and allow the saw blade to stop rotating before raising the blade out of workpiece. Wait until the electric brake stops blade from turning before removing the workpiece from miter table.
- When cutting long pieces of lumber or molding, support the opposite end of the stock with a roller stand or with a work surface level with the saw table. See Figure 39.
- Align the cutting line on the workpiece with the edge of saw blade.

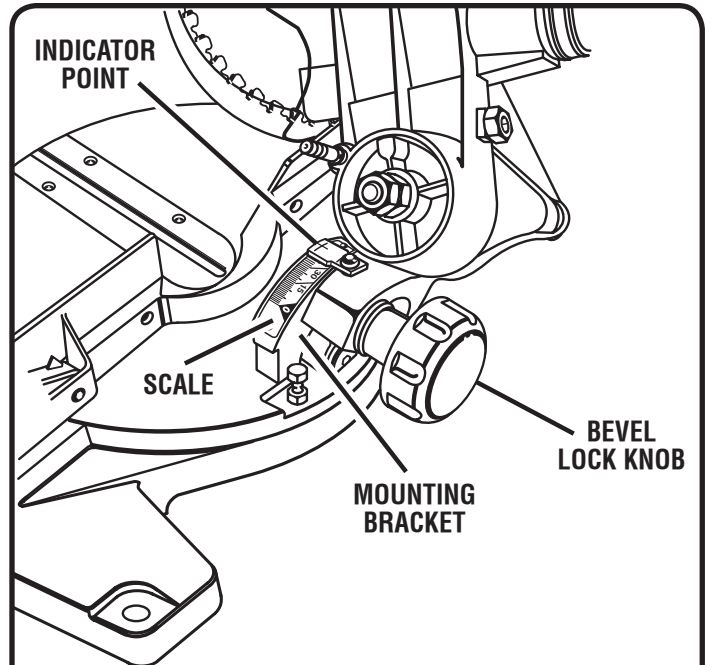

Fig. 35

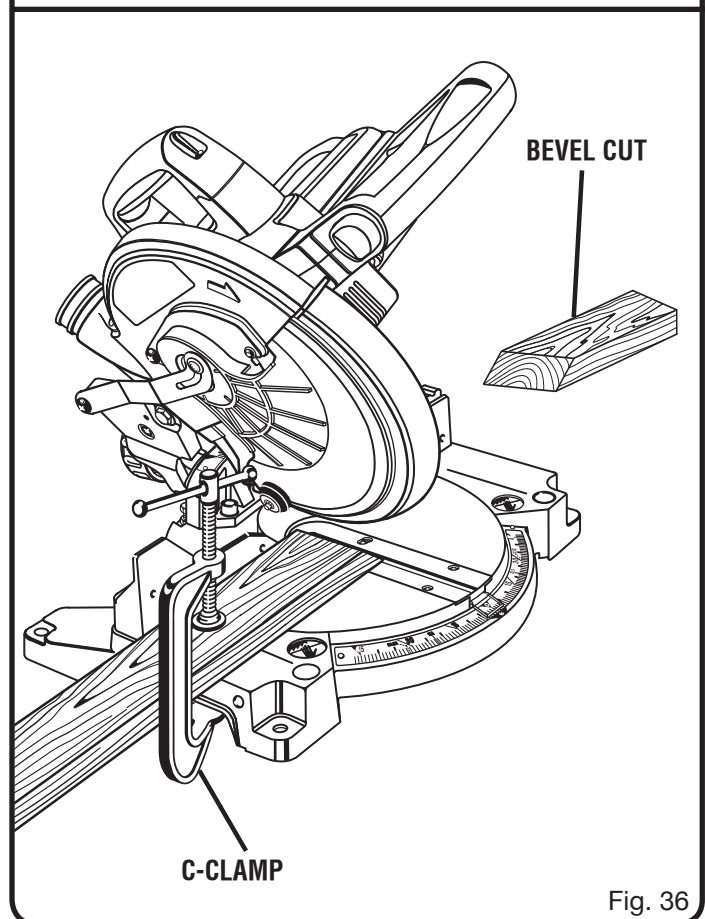

Fig. 36

OPERATION

- Grasp the stock firmly with one hand and secure it against the fence. Use the optional work clamp or a C-clamp to secure the workpiece when possible. *See Figure 36.*
- Before turning on the saw, perform a dry run of the cutting operation just to make sure that no problems will occur when the cut is made.
- Grasp the saw handle firmly, depress the switch lock, then squeeze the switch trigger. Allow several seconds for the blade to reach maximum speed.
- Slowly lower the blade into and through the workpiece.
- Release the switch trigger and allow the saw blade to stop rotating before raising the blade out of workpiece. Wait until the electric brake stops blade from turning before removing the workpiece from miter table.

TO COMPOUND MITER CUT

See Figure 37.

A compound miter cut is a cut made using a miter angle and a bevel angle at the same time. This type of cut is used to make picture frames, cut molding, make boxes with sloping sides, and for certain roof framing cuts.

To make this type of cut the control arm on the miter table must be rotated to the correct angle and the saw arm must be tilted to the correct bevel angle. Care should always be taken when making compound miter setups due to the interaction of the two angle settings.

Adjustments of miter and bevel settings are interdependent with one another. Each time you adjust the miter setting you change the effect of the bevel setting. Also, each time you adjust the bevel setting you change the effect of the miter setting.

It may take several settings to obtain the desired cut. The first angle setting should be checked after setting the second angle, since adjusting the second angle affects the first.

Once the two correct settings for a particular cut have been obtained, always make a test cut in scrap material before making a finish cut in good material.

- Pull out the lock pin and lift saw arm to its full height.
- Lift the miter table clamp.
- Rotate the miter table until the pointer aligns with zero on the miter scale.
- Push the miter table clamp down to lock.

NOTE: You can quickly locate 0°, 15°, 22-1/2°, left or right, 30° and 45° left or right by releasing the miter lock plate as you rotate the control arm. The miter lock plate will seat itself in one of the positive stop notches, located in miter table frame.

- Loosen the bevel lock knob and move the saw arm to the left to the desired bevel angle.
- Bevel angles can be set from 0° to 45°.

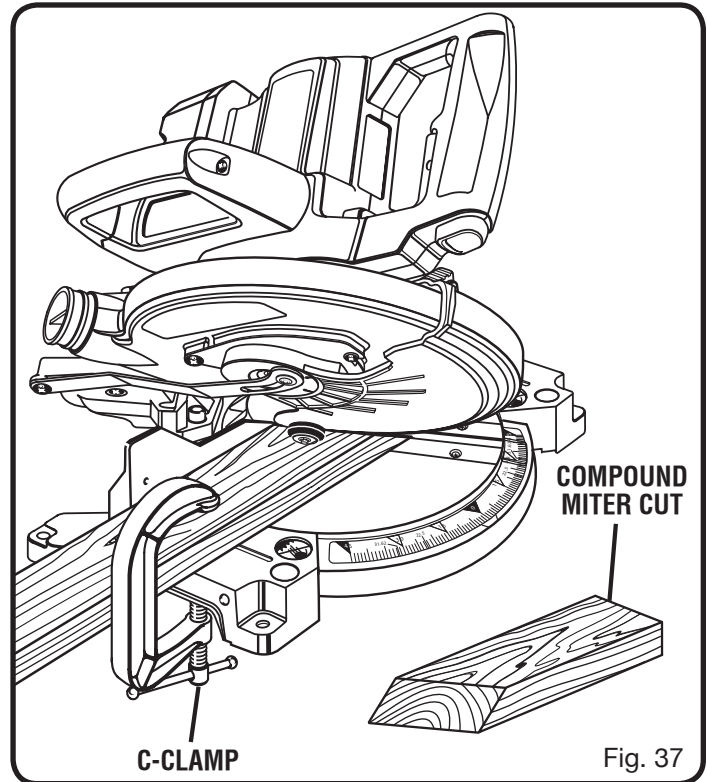

- Once the saw arm has been set at the desired angle, securely tighten the bevel lock knob.
- Recheck miter angle setting. Make a test cut in scrap material.
- Place the workpiece flat on the miter table with one edge securely against the fence. If the board is warped, place the convex side against the fence. If the concave edge of a board is placed against the fence, the board could collapse on the blade at the end of the cut, jamming the blade. *See Figures 41 - 42.*
- When cutting long pieces of lumber or molding, support the opposite end of the stock with a roller stand or with a work surface level with the saw table. *See Figure 38.*
- Align the cutting line on the workpiece with the edge of saw blade.

OPERATION

- Grasp the stock firmly with one hand and secure it against the fence. Use the optional work clamp or a C-clamp to secure the workpiece when possible. *See Figure 35.*
- Before turning on the saw, perform a dry run of the cutting operation just to make sure that no problems will occur when the cut is made.
- Grasp the saw handle firmly, depress the switch lock, then squeeze the switch trigger. Allow several seconds for the blade to reach maximum speed.
- Slowly lower the blade into and through the workpiece. *See Figures 35 - 36.*
- Release the switch trigger and allow the saw blade to stop rotating before raising the blade out of workpiece. Wait until the electric brake stops blade from turning before removing the workpiece from miter table.

TO SUPPORT LONG WORKPIECES

See Figure 39.

Long workpieces need extra supports. Supports should be placed along the workpiece so it does not sag. The support should let the workpiece lay flat on the base of the saw and work table during the cutting operation. Use the optional work clamp or a C-clamp to secure the workpiece.

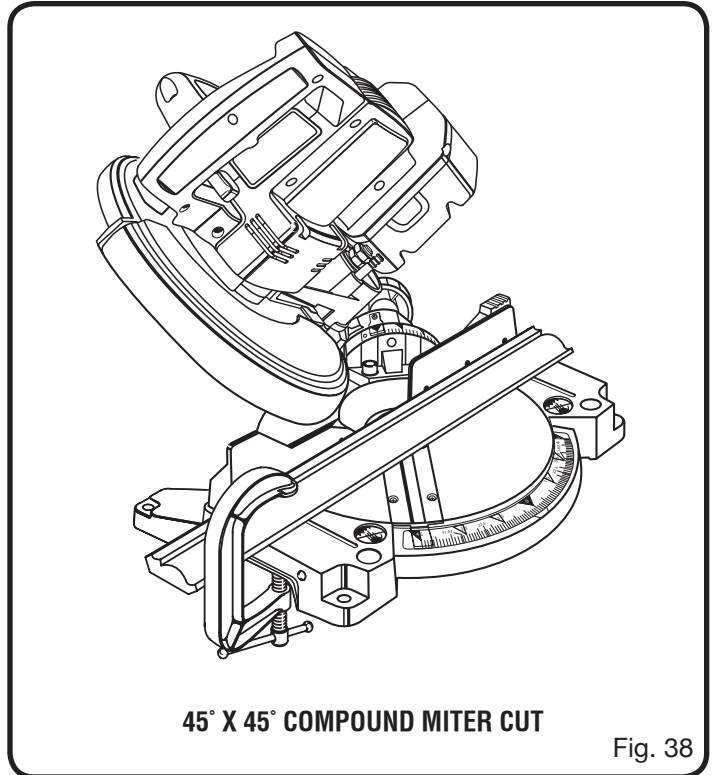

Fig. 38

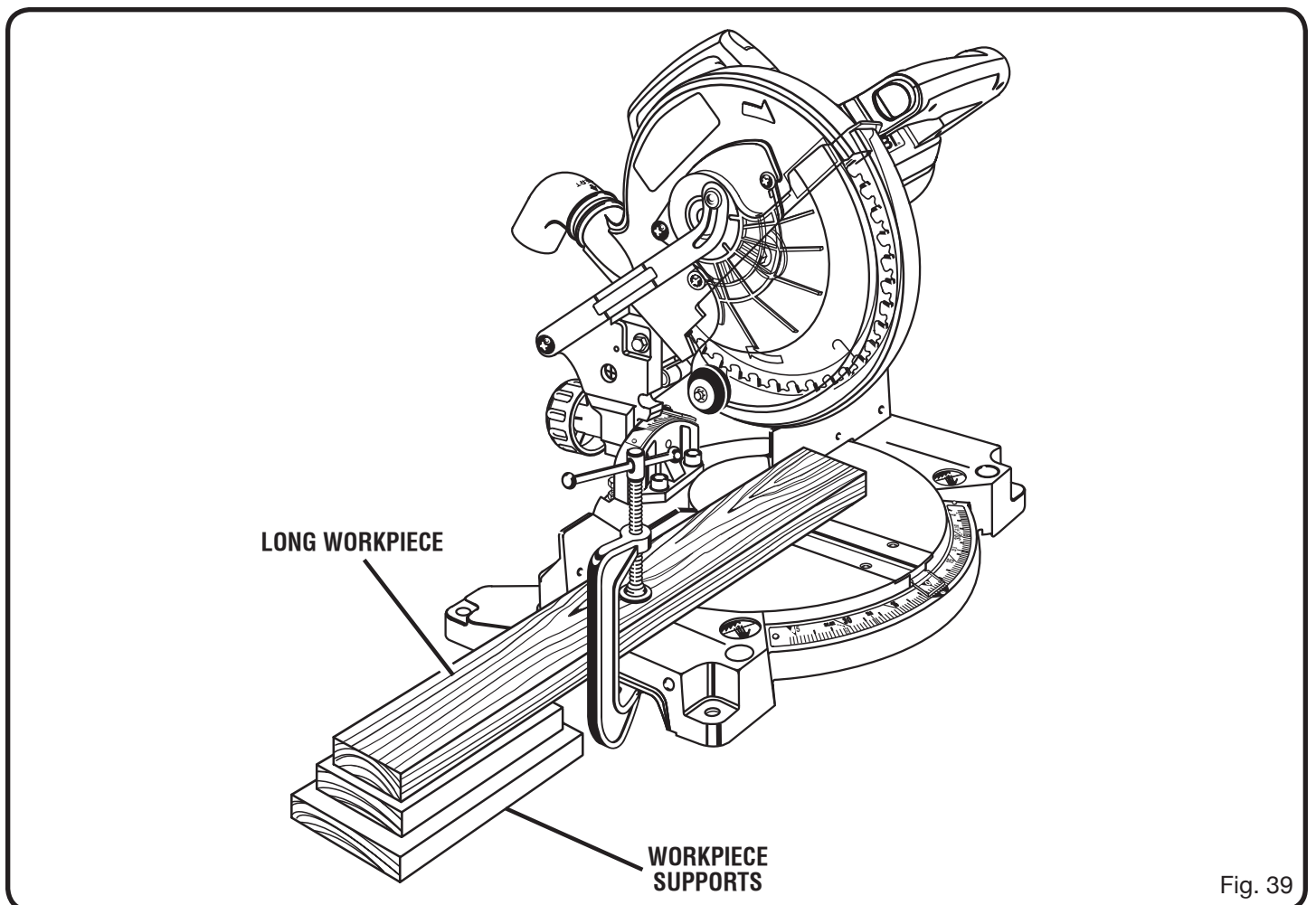

Fig. 39

OPERATION

CUTTING COMPOUND MITERS

To aid in making the correct settings, the compound angle setting chart below has been provided. Since compound cuts are the most difficult to accurately obtain, trial cuts should be made in scrap material, and much thought and planning made, prior to making the required cut.

PITCH OF SIDE	NUMBER OF SIDES						
	4	5	6	7	8	9	10
0°	M- 45.00° B- 0.00°	M- 36.00° B- 0.00°	M- 30.00° B- 0.00°	M- 25.71° B- 0.00°	M- 22.50° B- 0.00°	M- 20.00° B- 0.00°	M- 18.00° B- 0.00°
5°	M- 44.89° B- 3.53°	M- 35.90° B- 2.94°	M- 29.91° B- 2.50°	M- 25.63° B- 2.17°	M- 22.42° B- 1.91°	M- 19.93° B- 1.71°	M- 17.94° B- 1.54°
10°	M- 44.56° B- 7.05°	M- 35.58° B- 5.86°	M- 29.62° B- 4.98°	M- 25.37° B- 4.32°	M- 22.19° B- 3.81°	M- 19.72° B- 3.40°	M- 17.74° B- 3.08°
15°	M- 44.01° B- 10.55°	M- 35.06° B- 8.75°	M- 29.15° B- 7.44°	M- 24.95° B- 6.45°	M- 21.81° B- 5.68°	M- 19.37° B- 5.08°	M- 17.42° B- 4.59°
20°	M- 43.22° B- 14.00°	M- 34.32° B- 11.60°	M- 28.48° B- 9.85°	M- 24.35° B- 8.53°	M- 21.27° B- 7.52°	M- 18.88° B- 6.72°	M- 16.98° B- 6.07°
25°	M- 42.19° B- 17.39°	M- 33.36° B- 14.38°	M- 27.62° B- 12.20°	M- 23.56° B- 10.57°	M- 20.58° B- 9.31°	M- 18.26° B- 8.31°	M- 16.41° B- 7.50°
30°	M- 40.89° B- 20.70°	M- 32.18° B- 17.09°	M- 26.57° B- 14.48°	M- 22.64° B- 12.53°	M- 19.73° B- 11.03°	M- 17.50° B- 9.85°	M- 15.72° B- 8.89°
35°	M- 39.32° B- 23.93°	M- 30.76° B- 19.70°	M- 25.31° B- 16.67°	M- 21.53° B- 14.41°	M- 18.74° B- 12.68°	M- 16.60° B- 11.31°	M- 14.90° B- 10.21°
40°	M- 37.45° B- 27.03°	M- 29.10° B- 22.20°	M- 23.86° B- 18.75°	M- 20.25° B- 16.19°	M- 17.60° B- 14.24°	M- 15.58° B- 12.70°	M- 13.98° B- 11.46°
45°	M- 35.26° B- 30.00°	M- 27.19° B- 24.56°	M- 22.21° B- 20.70°	M- 18.80° B- 17.87°	M- 16.32° B- 15.70°	M- 14.43° B- 14.00°	M- 12.94° B- 12.62°
50°	M- 32.73° B- 32.80°	M- 25.03° B- 26.76°	M- 20.36° B- 22.52°	M- 17.20° B- 19.41°	M- 14.91° B- 17.05°	M- 13.17° B- 15.19°	M- 11.80° B- 13.69°
55°	M- 29.84° B- 35.40°	M- 22.62° B- 28.78°	M- 18.32° B- 24.18°	M- 15.44° B- 20.82°	M- 13.36° B- 18.27°	M- 11.79° B- 16.27°	M- 10.56° B- 14.66°
60°	M- 26.57° B- 37.76°	M- 19.96° B- 30.60°	M- 16.10° B- 25.66°	M- 13.54° B- 22.07°	M- 11.70° B- 19.35°	M- 10.31° B- 17.23°	M- 9.23° B- 15.52°
65°	M- 22.91° B- 39.86°	M- 17.07° B- 32.19°	M- 13.71° B- 26.95°	M- 11.50° B- 23.16°	M- 9.93° B- 20.29°	M- 8.74° B- 18.06°	M- 7.82° B- 16.26°
70°	M- 18.88° B- 41.64°	M- 13.95° B- 33.53°	M- 11.17° B- 28.02°	M- 9.35° B- 24.06°	M- 8.06° B- 21.08°	M- 7.10° B- 18.75°	M- 6.34° B- 16.88°
75°	M- 14.51° B- 43.08°	M- 10.65° B- 34.59°	M- 8.50° B- 28.88°	M- 7.10° B- 24.78°	M- 6.12° B- 21.69°	M- 5.38° B- 19.29°	M- 4.81° B- 17.37°
80°	M- 9.85° B- 44.14°	M- 7.19° B- 35.37°	M- 5.73° B- 29.50°	M- 4.78° B- 25.30°	M- 4.11° B- 22.14°	M- 3.62° B- 19.68°	M- 3.23° B- 17.72°
85°	M- 4.98° B- 44.78°	M- 3.62° B- 35.84°	M- 2.88° B- 29.87°	M- 2.40° B- 25.61°	M- 2.07° B- 22.41°	M- 1.82° B- 19.92°	M- 1.62° B- 17.93°
90°	M- 0.00° B- 45.00°	M- 0.00° B- 36.00°	M- 0.00° B- 30.00°	M- 0.00° B- 25.71°	M- 0.00° B- 22.50°	M- 0.00° B- 20.00°	M- 0.00° B- 18.00°

Each B (Bevel) and M (Miter) Setting is Given to the Closest 0.005°.

COMPOUND-ANGLE SETTINGS FOR POPULAR STRUCTURES

OPERATION

CUTTING CROWN MOLDING

The compound miter saw does an excellent job of cutting crown molding. In general, compound miter saws do a better job of cutting crown molding than any other tool made.

In order to fit properly, crown molding must be compound mitered with extreme accuracy.

The two contact surfaces on a piece of crown molding that fit flat against the ceiling and the wall of a room are at angles that, when added together, equal exactly 90° . Most crown molding has a top rear angle (the section that fits flat against the ceiling) of 52° and a bottom rear angle (the section that fits flat against the wall) of 38° .

LAYING MOLDING FLAT ON THE MITER TABLE

See Figure 40.

To use this method for accurately cutting crown molding for a 90° inside or outside corner, lay the molding with its broad back surface flat on the miter table and against the fence.

When setting the bevel and miter angles for compound miters, remember that the settings are interdependent; changing one angle changes the other angle as well.

Keep in mind that the angles for crown moldings are very precise and difficult to set. Since it is very easy for these angles to shift, all settings should first be tested on scrap molding. Also most walls do not have angles of exactly 90° , therefore, you will need to fine tune your settings.

When cutting crown molding by this method the bevel angle should be set at 33.85° . The miter angle should be set at 31.62° either right or left, depending on the desired cut for the application. See the chart below for correct angle settings and correct positioning of crown molding on miter table.

The settings in the chart on page 29 can be used for cutting All Standard (U.S.) crown molding with 52° and 38° angles. The crown molding is placed flat on the miter table using the compound features of your miter saw.

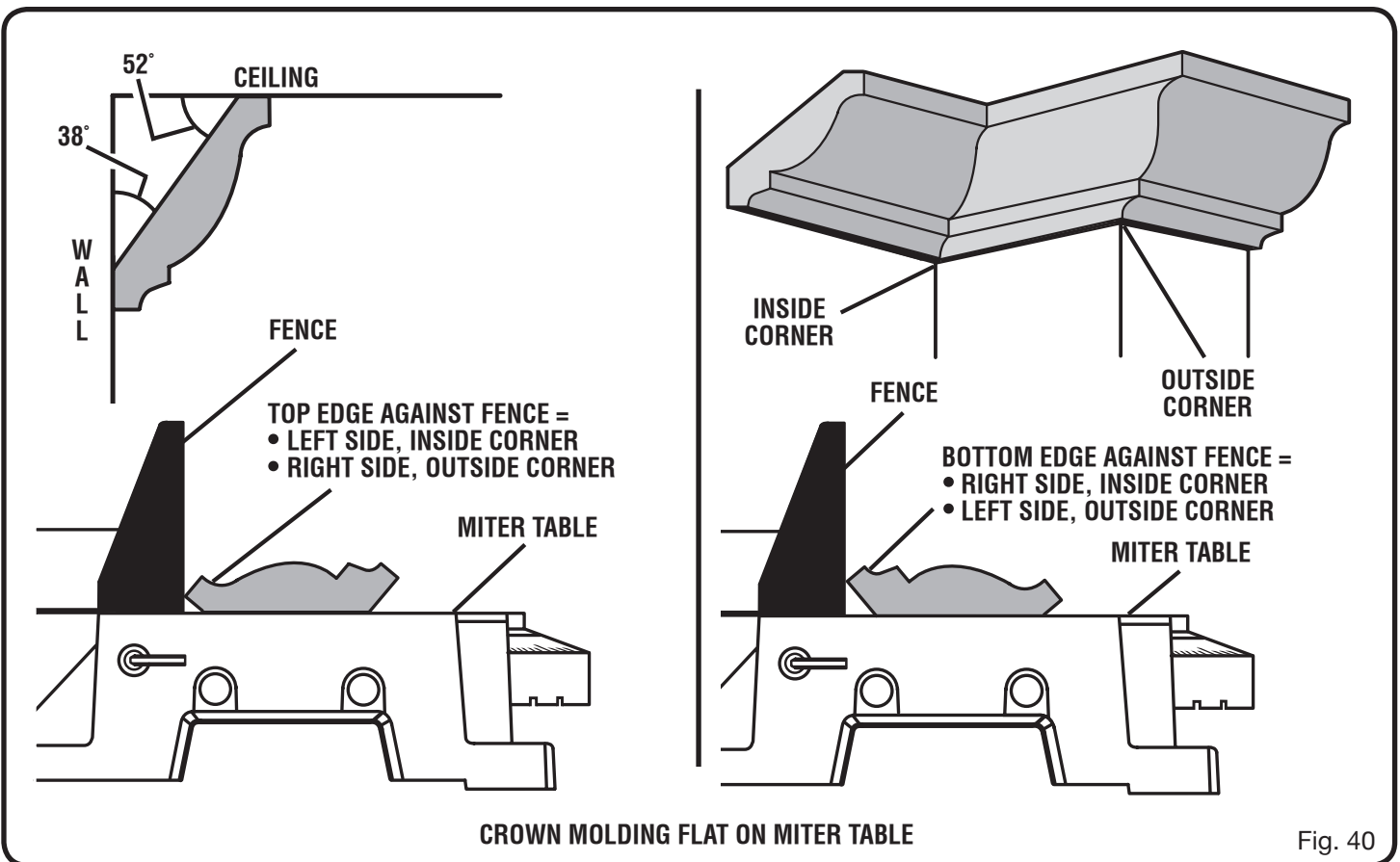

Fig. 40

OPERATION

Bevel Angle Setting	Type of Cut
33.85°	Left side, inside corner 1. Top edge of molding against fence 2. Miter table set right 31.62° 3. Save left end of cut
33.85°	Right side, inside corner 1. Bottom edge of molding against fence 2. Miter table set left 31.62° 3. Save left end of cut
33.85°	Left side, outside corner 1. Bottom edge of molding against fence 2. Miter table set left 31.62° 3. Save right end of cut
33.85°	Right side, outside corner 1. Top edge of molding against fence 2. Miter table set right 31.62° 3. Save right end of cut

CUTTING WARPED MATERIAL

See Figures 41 - 42.

When cutting warped material, always make sure it is positioned on the miter table with the convex side against the fence as shown in figure 41.

If the warped material is positioned the wrong way as shown in figure 42, it will pinch the blade near the completion of the cut.

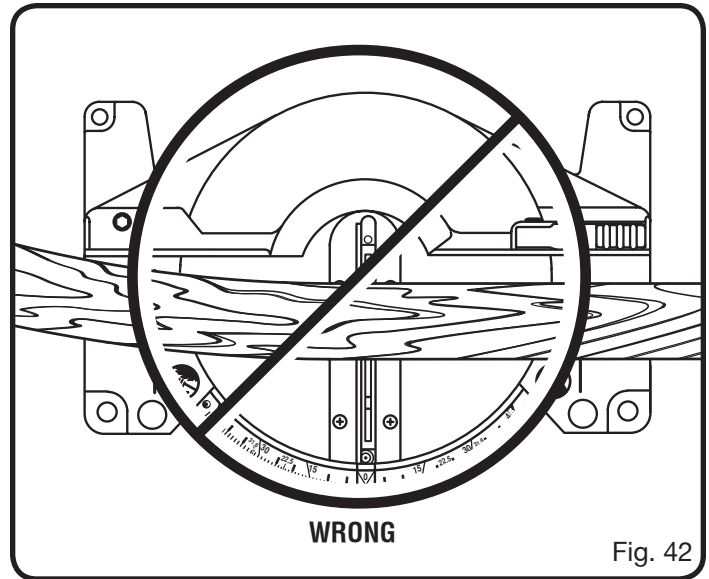
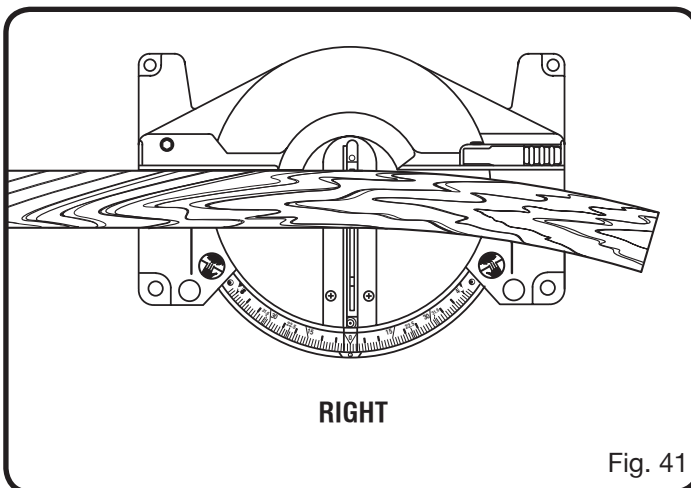

WARNING:

To avoid a kickback and to avoid serious personal injury, never position the concave edge of bowed or warped material against the fence.

CLAMPING WIDE WORKPIECES

When cutting wide workpieces, such as 52 in. x 6 in., boards should be clamped with a C-clamp.

ADJUSTMENTS

⚠ WARNING:

To prevent accidental starting that could cause serious personal injury, always remove the battery pack from the tool when making adjustments.

The compound miter saw has been adjusted at the factory for making very accurate cuts. However, some of the components might have been jarred out of alignment during shipping. Also, over a period of time, readjustment will probably become necessary due to wear. After unpacking the saw, check the following adjustments before you begin using saw. Make any readjustments that are necessary and periodically check the parts alignment to make sure that the saw is cutting accurately.

⚠ CAUTION:

Do not start the compound miter saw without checking for interference between the blade and the throat plate. Damage could result to the blade if it strikes the throat plate during operation of the saw.

PIVOT ADJUSTMENTS

NOTE: These adjustments were made at the factory and normally do not require readjustment.

TRAVEL PIVOT ADJUSTMENT

- The saw arm should rise completely to the up position by itself.
- If the saw arm does not raise by itself or if there is play in the pivot joints, have saw repaired at your nearest **RYOBI AUTHORIZED SERVICE CENTER**.

BEVEL PIVOT ADJUSTMENT

- The compound miter saw should bevel easily by loosening the bevel lock knob and tilting the saw arm to the left.
- If movement is tight or if there is play in the pivot, have saw repaired by at your nearest **RYOBI AUTHORIZED SERVICE CENTER**.

DEPTH STOP

The depth stop limits the blade's downward travel. It allows the blade to go below the miter table enough to maintain full cutting capacities. The depth stop positions the blade 1/4 in. from the miter table support.

NOTE: The miter table support is located inside miter table.

The depth stop is factory set to provide maximum cutting capacity for the 8-1/4 in. blade provided with the saw. Therefore, the saw with blade provided should never need adjustments.

However, when the diameter of the blade has been reduced due to sharpening, it may be necessary to adjust the depth stop to provide maximum cutting capacity. Also, when a new blade is installed, it is necessary to check the clearance of the blade to the miter table support before starting the saw. Make adjustments if needed.

DEPTH STOP ADJUSTMENTS

See Figure 43.

- Remove the battery pack from the tool.
- To adjust the depth stop use a 17 mm wrench or adjustable wrench and loosen the hex nut at the rear of the miter saw arm.
- Use the 5 mm hex key provided to adjust the depth stop adjustment screw. The saw blade is lowered by turning the screw counterclockwise and raised by turning the screw clockwise.
- Lower the blade into the throat plate of the miter table. Check blade clearance and maximum cutting distance (distance from fence where blade enters) to front of miter table slot.
- Readjust if necessary.

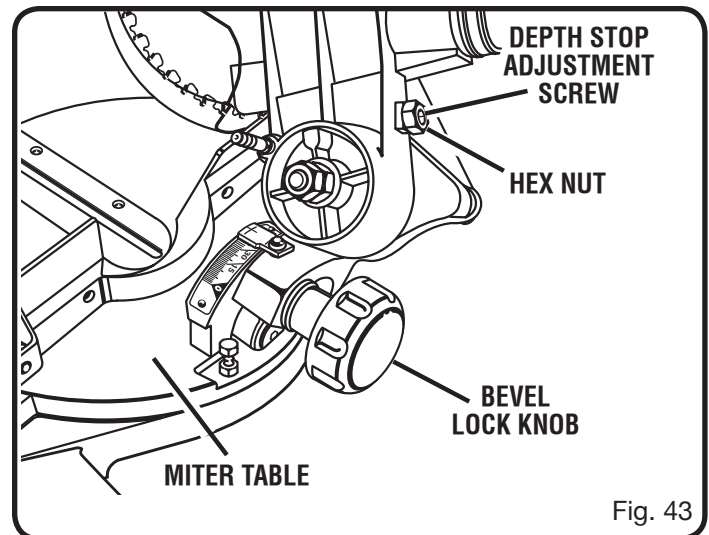

Fig. 43

MAINTENANCE

WARNING:

When servicing, use only identical Ryobi replacement parts. Use of any other parts may create a hazard or cause product damage.

WARNING:

Always wear safety goggles or safety glasses with side shields during power tool operation or when blowing dust. If operation is dusty, also wear a dust mask.

WARNING:

To avoid serious personal injury, always remove the battery pack from the tool when cleaning or performing any maintenance.

GENERAL MAINTENANCE

Avoid using solvents when cleaning plastic parts. Most plastics are susceptible to damage from various types of commercial solvents and may be damaged by their use. Use clean cloths to remove dirt, dust, oil, grease, etc.

WARNING:

Do not at any time let brake fluids, gasoline, petroleum-based products, penetrating oils, etc., come in contact with plastic parts. Chemicals can damage, weaken or destroy plastic which may result in serious personal injury.

Only the parts shown on the parts list are intended to be repaired or replaced by the customer. All other parts should be replaced at a Ryobi Authorized Service Center.

BATTERIES

The battery pack for this tool is equipped with nickel-cadmium rechargeable batteries. Length of service from each charging will depend on the type of work you are doing.

The batteries in this tool have been designed to provide maximum trouble-free life. However, like all batteries, they will eventually wear out. **Do not** disassemble battery pack and attempt to replace the batteries. Handling of these batteries, especially when wearing rings and jewelry, could result in a serious burn.

To obtain the longest possible battery life, we suggest the following:

- Remove the battery pack from the charger once it is fully charged and ready for use.

For battery storage longer than 30 days:

- Store the battery pack where the temperature is below 80°F.
- Store battery packs in a “discharged” condition.

BATTERY PACK REMOVAL AND PREPARATION FOR RECYCLING



To preserve natural resources, please recycle or dispose of batteries properly.

This product contains nickel-cadmium batteries. Local, state or federal laws may prohibit disposal of nickel-cadmium batteries in ordinary trash.

Consult your local waste authority for information regarding available recycling and/or disposal options.

WARNING:

Upon removal, cover the battery pack's terminals with heavy-duty adhesive tape. Do not attempt to destroy or disassemble battery pack or remove any of its components. Nickel-cadmium batteries must be recycled or disposed of properly. Also, never touch both terminals with metal objects and/or body parts as short circuit may result. Keep away from children. Failure to comply with these warnings could result in fire and/or serious injury.



OPERATOR'S MANUAL

8-1/4 in., 18 Volt Cordless Compound Miter Saw P550

- **SERVICE**

Now that you have purchased your tool, should a need ever exist for repair parts or service, simply contact your nearest Ryobi Authorized Service Center. Be sure to provide all pertinent facts when you call or visit. Please call 1-800-525-2579 for your nearest Ryobi Authorized Service Center. You can also check our web site at www.ryobitools.com for a complete list of Authorized Service Centers.

- **MODEL NO. AND SERIAL NO.**

The model number of this tool will be found on a plate attached to the motor housing. Please record the model number and serial number in the space provided below.

- **HOW TO ORDER REPAIR PARTS**

When ordering repair parts, always give the following information:

- MODEL NUMBER _____ P550 _____
- SERIAL NUMBER _____

RYOBI TECHNOLOGIES, INC.

1428 Pearman Dairy Road, Anderson, SC 29625
Post Office Box 1207, Anderson, SC 29622-1207

Phone 1-800-525-2579

www.ryobitools.com

Free Manuals Download Website

<http://myh66.com>

<http://usermanuals.us>

<http://www.somanuals.com>

<http://www.4manuals.cc>

<http://www.manual-lib.com>

<http://www.404manual.com>

<http://www.luxmanual.com>

<http://aubethermostatmanual.com>

Golf course search by state

<http://golfingnear.com>

Email search by domain

<http://emailbydomain.com>

Auto manuals search

<http://auto.somanuals.com>

TV manuals search

<http://tv.somanuals.com>