

# *Sunbeam*

## **SERVICE MANUAL**

### **EM6910**

### **Dual Thermoblock Block**

### **Coffee Machine**



**ISSUE: A**

**DATE: 1/02/2007**

## SPARE PARTS LIST

**Note: Not all parts are available as spare parts. Please check price list.**

Item	Description	Sunbeam Part No.
	Filter anti-calc cartridge	EM69101
Page 5, #11	Cleaning disc	EM69102
Page 6, # 1 - 4	Filter handle assembly	EM69103
Page 5, #31	Measuring spoon	EM69104
Page 5, #35	Tamp	EM69105
Page 7, # 1 - 11	Water tank assembly	EM69106
Page 5, # 52	1 cup filter single wall	EM69107
Page 5, # 53	2 cup filter single wall	EM69108
Page 5, # 20	Milk frothing jug 800ml	EM69109
	Steam tube assembly	EM69110
	Valve assembly	EM69112
	Brew head seal	EM69116
	Steam / water valve assembly + steam pin	EM69117
Page 5, # 3	Rear door hinge screw	EM69118
	New piping sets	EM69122
	Tension anti-drip spring	EM69128
	Solenoid valve assembly	EM69129
	Steam thermoblock	EM69131
Page12, # 6	Coffee water pump assembly	EM69132
Page 12, # 1, 2	Brass fitting for S2 valve	EM69132B
Page 12, # 3, 4	S2 valve & oring	EM69132C
	Dial actuator	EM69134
	Screw for actuator	EM69135
Page 5, # 33	Hot water and steam dial knob	EM69138
	Hot water arm	EM69139
	Hot water steam valve assembly mount screw	EM69140
	T-bar brass fitting	EM69143
	Anti-drip silicon valve	EM69147
	Long wire microswitch for hot water dial	EM69148
	Short wire microswitch for steam dial	EM69149
	Cable ties	EM69150
	Baffle	EM69152
Page 8, # 24	Screw for thermoblock	EM69153
Page 5, # 38	Warming plate	EM69155
Page 5, # 13	Drip tray connector	EM69156
Page 6, # 1	Filter cradle wire for EM69103	EM69157
Page 8, #2	Shower Head Plate	EM69158
	Single Pour Spout	EM69160
	Dual Pour Spout	EM69161
	Dumping Nozzle Brass Insert	EM69162
Page 9, # 8	Steam Chamber Wire/Thermal Fuse Assembly	EM69163
	Coffee Block Wire/Thermal Fuse Assembly	EM69164
Page 14, # 5	Water Tank Valve Body	EM69165
Page 14, # 4	Water Tank Valve Rubber Ring	EM69166
	Spacer for Brew Head Seal	EM69167
Page 13, #10,14	New steam nozzle EM6900/6910/6910R	EM69168
Page 5, #35	New tamp EM6900/6910/6910R	EM69169
Page 4, #3	Flow meter assembly EM6900/6910/6910R	EM69170



# EXPLODED VIEW DRAWING

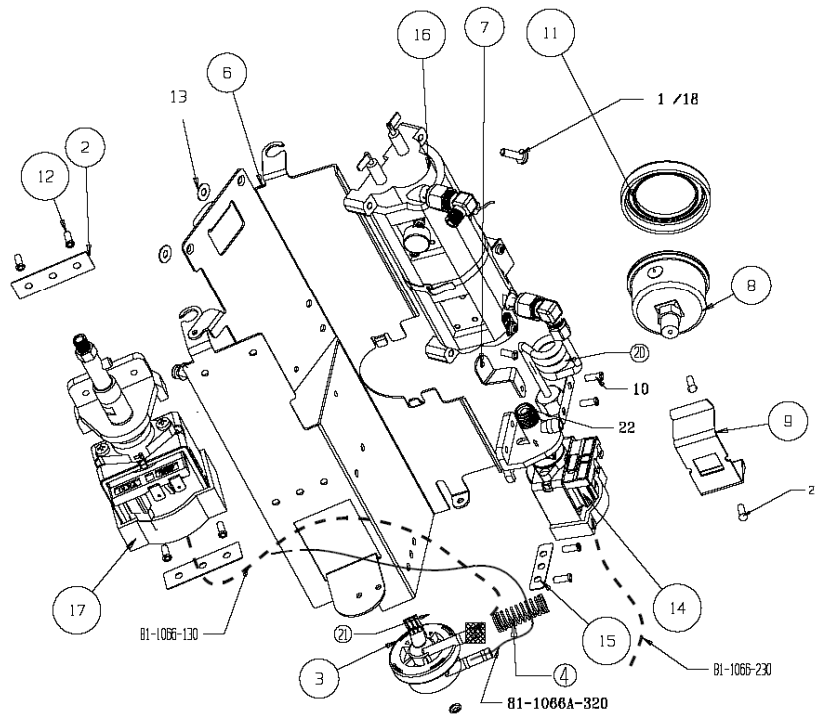

NO.	PART NO.	PART NAME	MATERIAL	QTY
1	31-4021	M4*22		4
2	C23-2009-G	COFFEE PUMP SUPPORT		2
3	S0-4002	FLOW METER ASSY		1
4	38-5083	FLOWMETER SPRING		2
5	33-10D1	M3		1
6	C23-1114VF-G	MAIN HOUSING BRACKET		1
7	C23-745B-G	MAIN HOUSING BRACKET CONNECTOR		1
8	S0-40D1	PRESSURE GAUGE		1
9	C23-2007VC_G	PRESSURE GAUGE BRACKET		1
10	35-1022	BLIND RIVET 1/8 x 1/4"		3
11	C3-9019	PRESSURE GAUGE PLASTIC BRACKET		1
12	35-1037	BLIND RIVET DIA3.5*10MM		8
13	34-1015	SLEEVE		4
14	18-B1D3	SMALL PUMP ASSY		1
15	C23-2010-G	SMALL PUMP SUPPORT		2
16	18-B1D2	THERMOCHAMBER ASSY		1
17	18-B1D5	WATER PUMP ASSY		1
18	34-2010	spring sleeve		4
19	81-1066A-170	SILICON TUBE		1
20	C23-2245	COPPER TUBE		1
21	D3-3008	CABLE TIE		2
22	45-7038	STEAM ADAPTOR O RING		1
23	31-1142	M3.D SCREW		2

DOCUMENT NO.	(11/20)	SCALE	1:2	UNIT	mm
PART NO.	81-8109	DESIGNED BY			
DRAWING OR PART NAME	MAIN HOUSING ASSY	DRAWN BY			
MATERIAL		CHECKED BY			
FINISH		APPROVED BY			
FILE DIR					

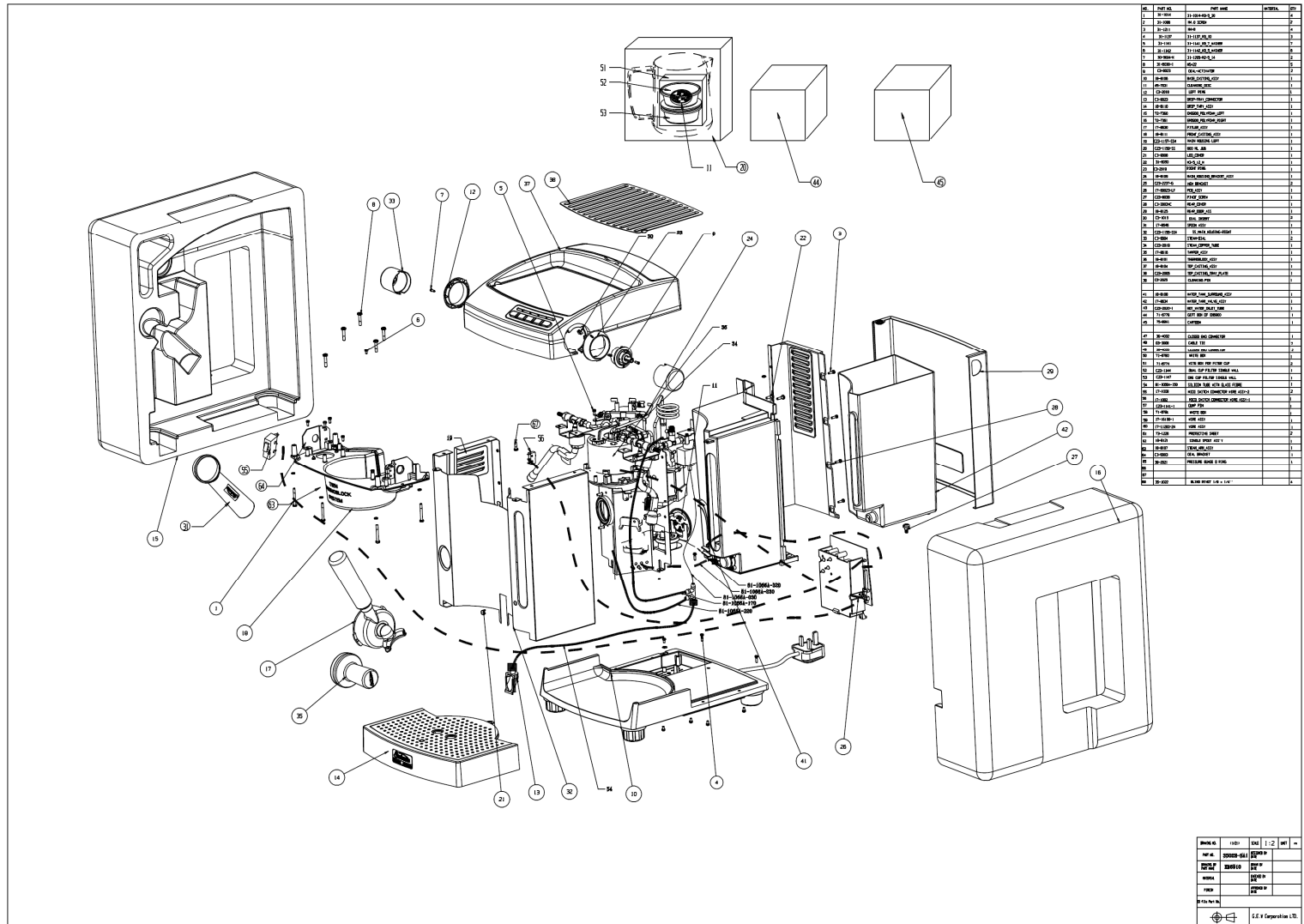

REVISION				
Mark	Description	Initiated by	Approved by	Date
1	PERFECTION RELEASE			

NO.	PART NO.	PART NAME	MATERIAL	QTY
1	C23-745310-SS	FILTER CRADLE WIRE	SUS 304(DI.BMM)	1
2	17-8648-2	DUAL SPOUT ASSY	BRASS (HSB)	1
3	C3-4001	HANDLE	PHENOLIC	1
3.1	C23-8000	HANDLE INSERT	BRASS(HSB)	1
4	00-3624	LOCTITE 2220	---	D.16

DOCUMENT NO.	17-8630	SCALE	1:1	UNIT	mm
PART NO.	17-8630	DESIGNED BY	DATE	KIANG 29/09/06	
DRAWING OR PART NAME	FILTER CRADLE ASS'Y	DRAWN BY	DATE	KIANG 29/09/06	
MATERIAL	---	CHECKED BY	DATE	ROBERT 29/09/06	
FINISH	---	APPROVED BY	DATE	ROBERT 29/09/06	
FILE DIR	17-8630_00_0160930				
		G. E. W Corporation LTD.			

装配要求:

- 零件 3 必须用螺纹胶 (零件 4) 紧密地与零件 2 固定, 且在扭力 10KG 下不可松脱
- 弹簧零件 1 装配时, 必须保证所有弧面都处于零件 2 的凹槽内

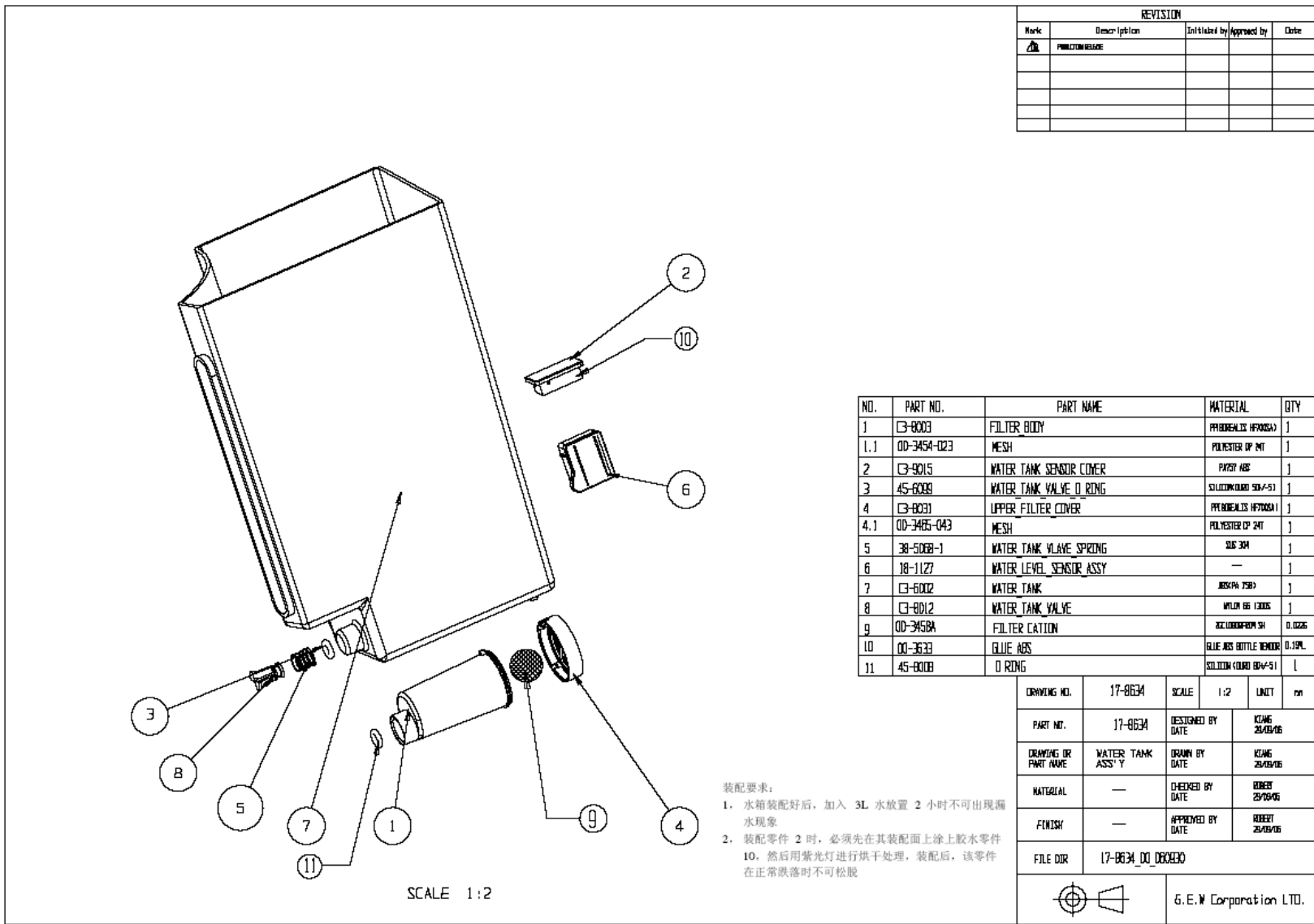

REVISION				
Mark	Description	Initiated by	Approved by	Date
1	PULLDOWN RELEASE			

NO.	PART NO.	PART NAME	MATERIAL	QTY
1	Q3-8003	FILTER BODY	PP/HDPE/LS (FROST)	1
1.1	00-3454-023	MESH	POLYESTER CP INT	1
2	Q3-8015	WATER TANK SENSOR COVER	PA66/PA6	1
3	45-8038	WATER TANK VALVE O RING	SILICON/ORD 004-51	1
4	Q3-8031	UPPER FILTER COVER	PP/HDPE/LS (FROST)	1
4.1	00-3465-043	MESH	POLYESTER CP 24T	1
5	38-5068-1	WATER TANK VALVE SPRING	SS 304	1
6	18-1127	WATER LEVEL SENSOR ASSY	—	1
7	Q3-6102	WATER TANK	ABS/PA 7507	1
8	Q3-8012	WATER TANK VALVE	NYLON 66 13005	1
9	00-3458A	FILTER CATION	AC LUBRIFORM SH	0.026
10	00-3533	GLUE TABS	GLUE ABS BOTTLE REMOVR	0.19M
11	45-8008	O RING	SILICON (ORD 004-51)	1

DRAWING NO.	17-8634	SCALE	1:2	UNIT	mm
PART NO.	17-8634	DESIGNED BY DATE	ICANG	28/05/06	
DRAWING OR PART NAME	WATER TANK ASSY 'Y'	DRAWN BY DATE	ICANG	28/05/06	
MATERIAL	—	CHECKED BY DATE	ROBERT	29/06/06	
FINISH	—	APPROVED BY DATE	ROBERT	28/05/06	
FILE DIR	17-8634_DO_DRAWING				
					G. E. W Corporation LTD.

- 装配要求:
- 水箱装配好后, 加入 3L 水放置 2 小时不可出现漏水现象
  - 装配零件 2 时, 必须先在其装配面上涂上胶水零件 10, 然后用紫光灯进行烘干处理, 装配后, 该零件在正常跌落时不可松脱

SCALE 1:2

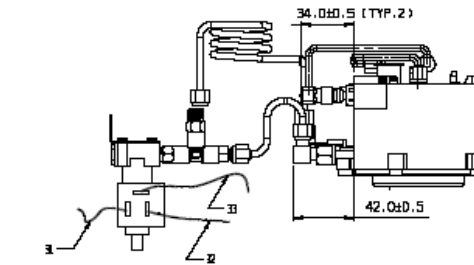
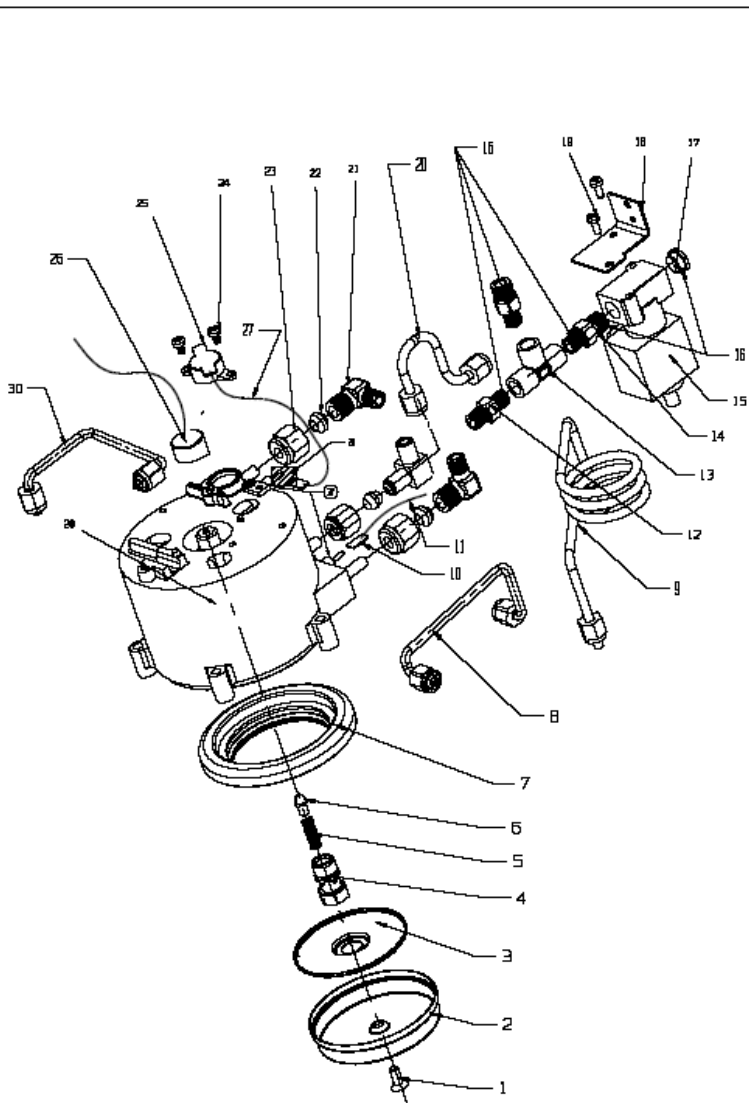

REVISION				
Mark	Description	Initiated by	Approved by	Date
▲	FUNCTION CHANGE			

NO.	PART NO.	PART NAME	MATERIAL	QTY
1	30-1280	SHDL HEAD SCRM	SLR 304	1
2	C20-0020H	SHDRS HEAD PLATE	SLR 304	1
3	C20-0020H	SPRSD SHDRS HEAD PLATE	SLR 304	1
4	C20-0104	SCRM	BRASS/HSN	1
5,1	30-0000-00-00 30-0000-00-00	WTRC WRT SPONGE	SLR 304	5
6	45-1004	WTRC WRT	SLR 304	1
7	45-0205	SHDRS HEAD SEAL	SL 310HM	1
8	C20-0020-1	COPPER TUBE	COPPER	1
9	C20-0020	THERMOLOCK OUTLET WATER TUBE	COPPER	1
10	36-3018	FERROCAL	NO PLATED	2
11	17-11400-3	WTRC ASBY	100 WTRC	1
12	C20-0100	NO. NO. ADAPTER	BRASS/HSN	1
13	C20-0104	NO. ADAPTER 2 WPT	BRASS/HSN	1
14	C20-0120	RL-1-1 ADAPTER	BRASS/HSN	2
15	50-0002	SOLENOID VALVE	CU/BI	1
16	40-2004	LACTITE 2000	LACTITE	0.50
17	C20-0003	SOLENOID VALVE BOLT	BRASS/HSN	1
18	C20-0004-4	SOLENOID VALVE BRACKET	S.T.	1
19	31-1144	KT 7 WASHER	NO PLATED	2
20	C20-0020	SOLENOID COPPER TUBE	COPPER	1
21	C20-0000	OUTLET LOCK ADAPTER	BRASS/HSN	1
22	C20-0012	THERMOLOCK COMPRESSIVE SLRONE	BRASS/HSN	3
23	C20-0011	THERMOLOCK THERMOLOCK MUT	BRASS/HSN	3
24	31-1142	KT 9 WASHER	NO PLATED	2
25	50-0000	THERMOLOCK 3 LUGS/RES	---	1
26	130-0000-25	THERMOLOCK	---	1
27	17-11200-31	WTRC ASBY	300 WTRC	1
28	C20-0000	THERMOLOCK OVERCAST	BLK/SLR 312	1
29	81-1000-400	SLR 304	---	2
30	C20-0000-1	THERMOLOCK OUTLET TUBE	COPPER	1
31	17-11100-20	WTRC ASBY	100 WTRC	1
32	17-11100-31	WTRC ASBY	100 WTRC	1
33	17-11200-32	WTRC ASBY	100 WTRC	1
34	30-2013	HEATER TANK COMP/DM	---	0.25
35	81-1010-000	SLR 304	---	2

DRAWING NO.	18-8101	SCALE	1:2	UNIT	mm
PART NO.	18-8101	DESIGNED BY	KING 29/05/05		
DRAWING OR PART NAME	THERMOLOCK ASS'Y	DRAWN BY	KING 29/05/05		
MATERIAL	---	CHECKED BY	ROBERT 29/05/05		
FINISH	---	APPROVED BY	ROBERT 29/05/05		

装配要求:

1. 所有接头在 15Bar 压力下不可漏水



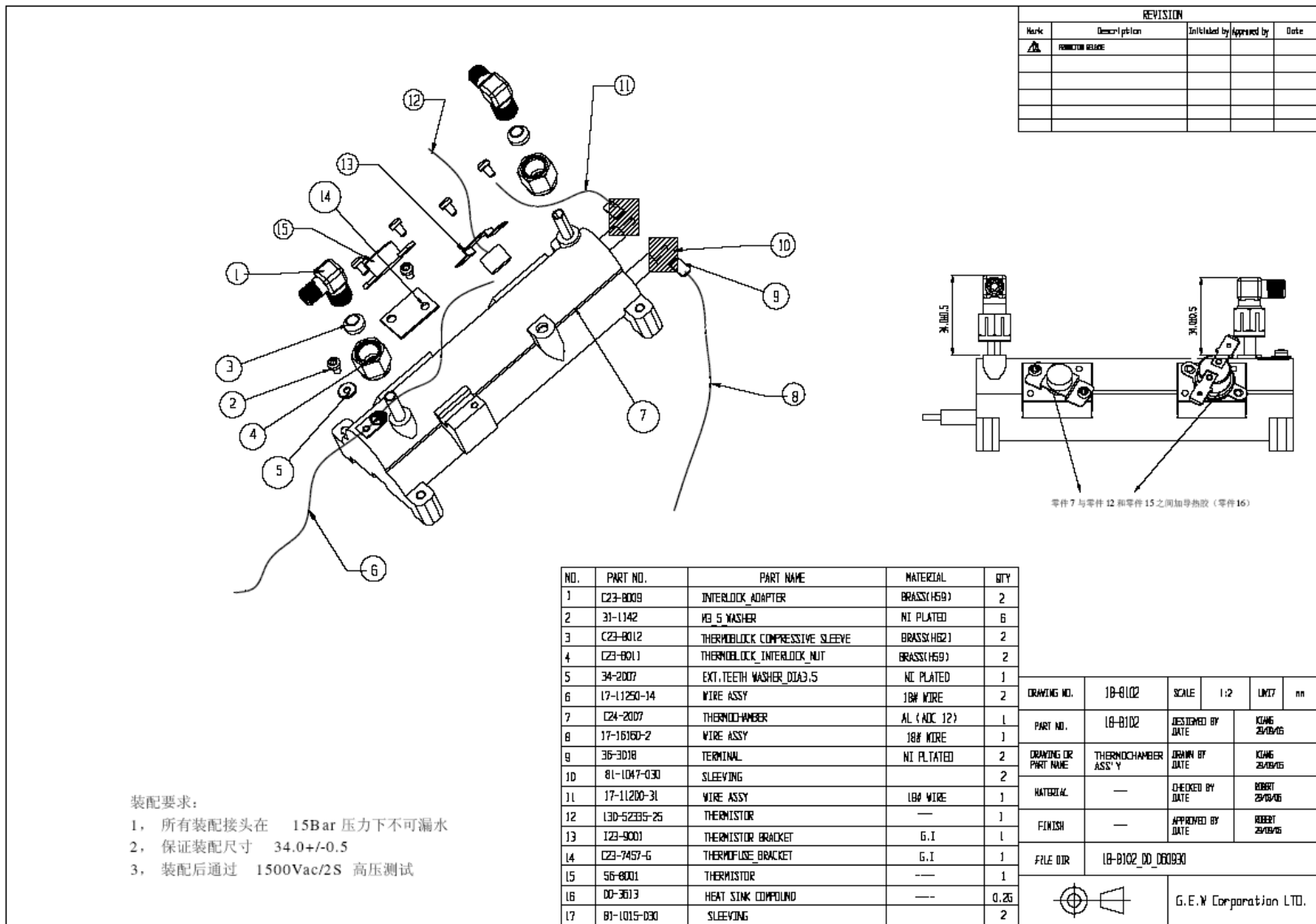

REVISION				
Mark	Description	Initiated by	Approved by	Date
A	FUNCTION RELEASE			

- 装配要求:
1. 所有装配接头在 15Bar 压力下不可漏水
  2. 保证装配尺寸 34.0+/-0.5
  3. 装配后通过 1500Vac/2S 高压测试

NO.	PART NO.	PART NAME	MATERIAL	QTY
1	C23-8009	INTERLOCK_ADAPTER	BRASS(H59)	2
2	31-1142	W3.5 WASHER	NI PLATED	6
3	C23-8012	THERMOBLOCK_COMPRESSIVE_SLEEVE	BRASS(H62)	2
4	C23-8011	THERMOBLOCK_INTERLOCK_NUT	BRASS(H59)	2
5	34-2007	EXT. TEETH WASHER_DIA3.5	NI PLATED	1
6	17-11250-14	WIRE ASSY	18# WIRE	2
7	C24-2007	THERMOCHAMBER	AL (A1C 12)	1
8	17-16160-2	WIRE ASSY	18# WIRE	1
9	36-3018	TERMINAL	NI PLATED	2
10	81-1047-030	SLEEVING		2
11	17-11200-31	WIRE ASSY	18# WIRE	1
12	130-52335-25	THERMISTOR	---	1
13	123-9001	THERMISTOR_BRACKET	G.I	1
14	C23-7457-6	THERMOFUSE_BRACKET	G.I	1
15	56-8001	THERMISTOR	---	1
16	00-3613	HEAT_SINK_COMPOUND	---	0.25
17	81-1015-030	SLEEVING		2

DRAWING NO.	18-8102	SCALE	1:2	UNIT	mm
PART NO.	18-8102	DESIGNED BY DATE		ICANG	25/05/05
DRAWING OR PART NAME	THERMOCHAMBER ASS'Y	DRAWN BY DATE		ICANG	25/05/05
MATERIAL	---	CHECKED BY DATE		ROBERT	25/05/05
FINISH	---	APPROVED BY DATE		ROBERT	25/05/05
FILE DIR	18-8102_DD_000930				
					G. E. Y Corporation LTD.

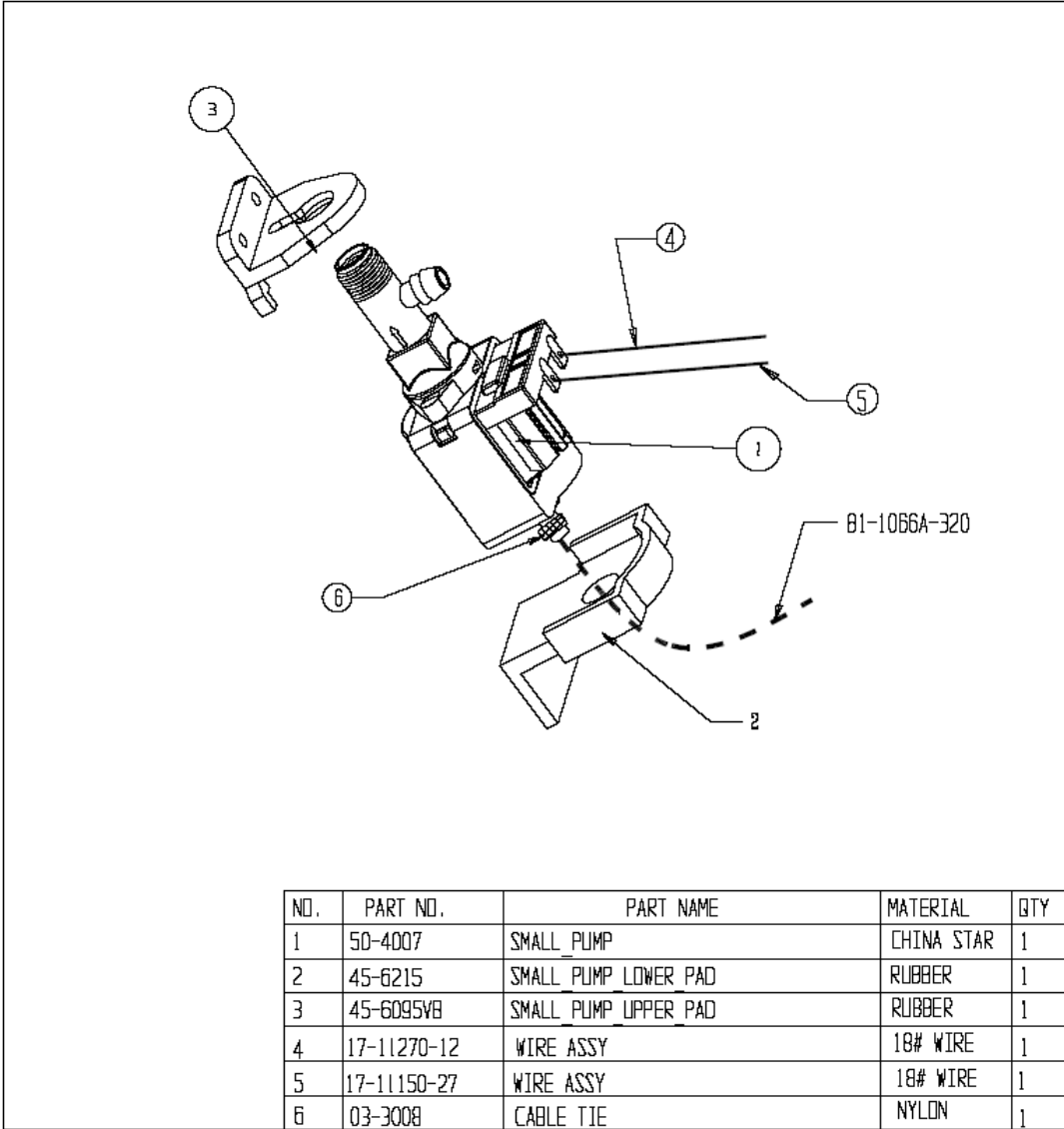

REVISION				
Mark	Description	Initiated by	Approved by	Date
1	PRODUCTION RELEASE			

NO.	PART NO.	PART NAME	MATERIAL	QTY
1	50-4007	SMALL_PUMP	CHINA STAR	1
2	45-6215	SMALL_PUMP LOWER PAD	RUBBER	1
3	45-6095VB	SMALL_PUMP UPPER PAD	RUBBER	1
4	17-11270-12	WIRE ASSY	18# WIRE	1
5	17-11150-27	WIRE ASSY	18# WIRE	1
6	03-3008	CABLE TIE	NYLON	1

DOCUMENT NO.	18-B103	SCALE	1:1	UNIT	m
PART NO.	18-B103	DESIGNED BY DATE	KIANG 30/09/06		
DRAWING OR PART NAME	STEAM PUMP ASS'Y	DRAWN BY DATE	KIANG 30/09/06		
MATERIAL	---	CHECKED BY DATE	ROBERT 30/09/06		
FINISH	---	APPROVED BY DATE	ROBERT 30/09/06		
FILE DIR	18--8103_00_060930				
		G. E. W Corporation LTD.			

REVISION				
Mark	Description	Initiated by	Approved by	Date
A	PRODUCTION RELEASE			

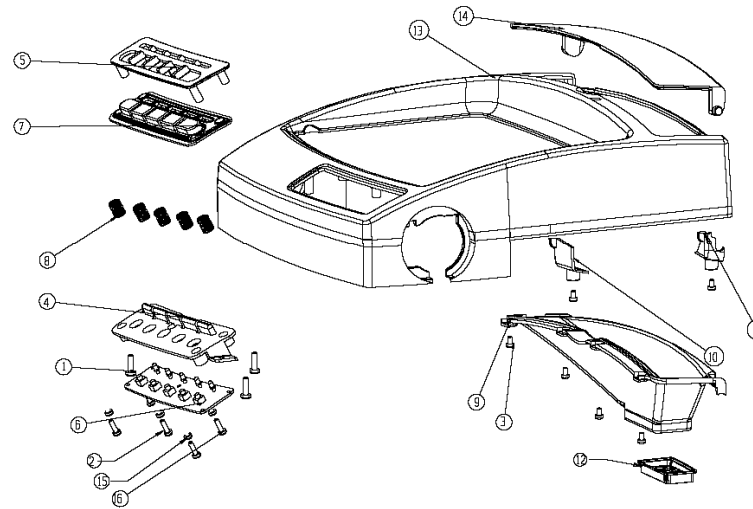

NO.	PART NO.	PART NAME	MATERIAL	QTY
1	31-1070	M3_SXB	NI PLATED	3
2	31-3004	M3KB_CDARSC	SUS 304	1
3	31-1107	M3K5	NI PLATED	6
4	C3-8002	CONTROL_PANEL_BRACKET	PC(MARRELLIN 2605 550115)	1
5	C3-3001	CONTROL_PANEL_COVER	PA657 ABS	1
6	17-9020	CONTROL_PANEL_PCB	---	1
7	45-6115	CONTROL_PANEL_RUBBER_PAD	SILICON	1
8	38-5073	COMPRESSION_SPRING	MUSIC WIRE	5
9	c3-8002	FUNNEL	PP(BUREALIS HF700SA)	1
10	C3-8001	FUNNEL_BRACKET_LEFT	PP(BUREALIS HF700SA)	1
11	C3-8018	FUNNEL_BRACKET_RIGHT	PP(BUREALIS HF700SA)	1
12	C3-8027	FUNNEL_FILTER	PP(BUREALIS HF700SA)	1
12.1	00-3454-040	MESH	POLYESTER	1
13	C24-1111	TOP_CASTING	AL CASTING (A.302)	1
14	C24-1110	TOP_CASTING_LID	AL CASTING (A.302)	1
15	34-7007	SLEEVING	FIBRE	5
16	31-1100	SCREW	NI PLATED	4

- 装配要求:
1. 顶盖门 14 和按板 5 装配时要与零件 13 连接弧面较顺, 无明显断差
  2. 顶盖门 14 装配后转动灵活, 与其它零件无干涉

DRAWING NO.	18-8104	SCALE	1:2	UNIT	mm
PART NO.	18-8104	DESIGNED BY	KIANG 28/09/06		
DRAWING OR PART NAME	TOP CASTING ASS'Y	DRAWN BY	KIANG 28/09/06		
MATERIAL	---	CHECKED BY	ROBERT 28/09/06		
FINISH	---	APPROVED BY	ROBERT 28/09/06		
FILE DIR	18-8104_00_060930				
					G.E.W Corporation LTD.

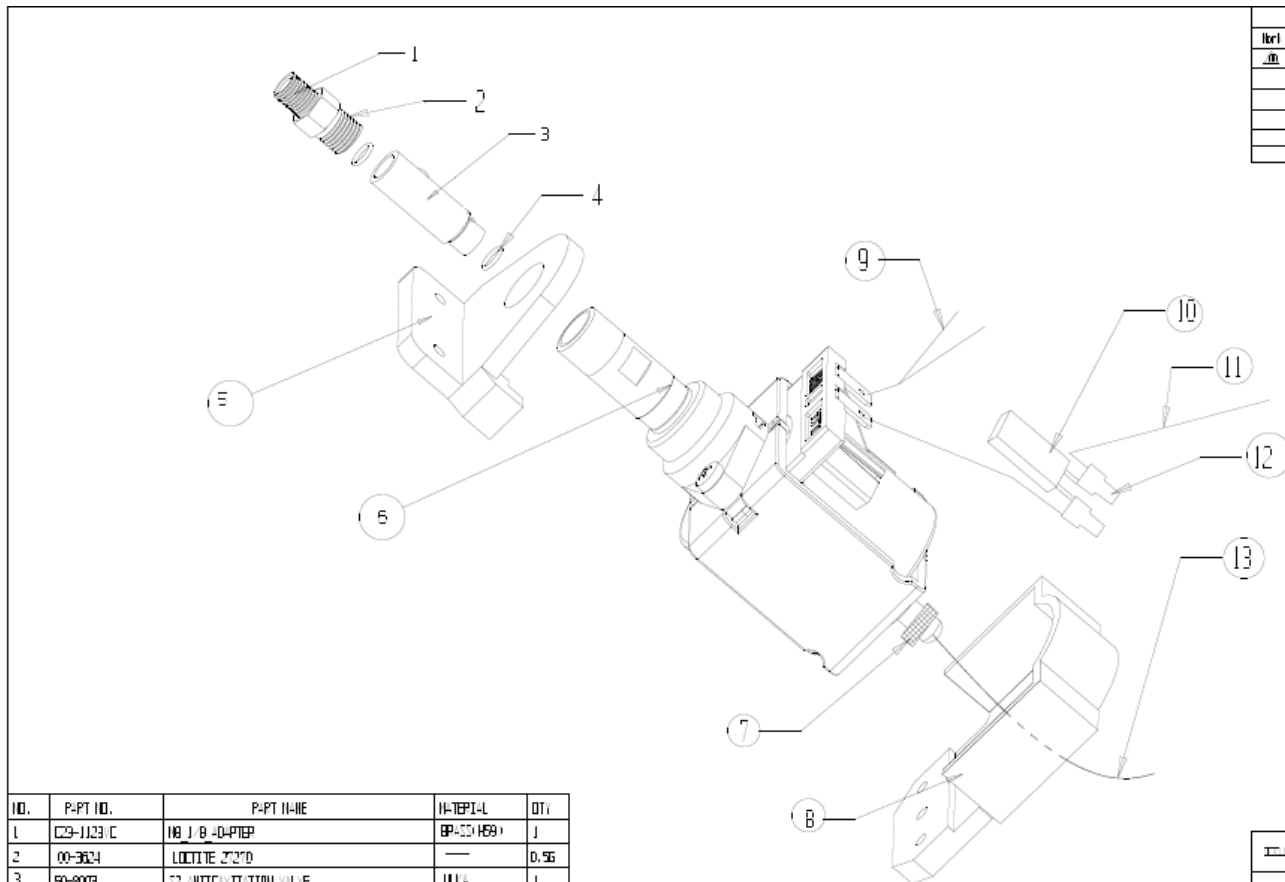

REVISION				
Rev#	Description	Initiated by	Approved by	Date
01	PRODUCTION			

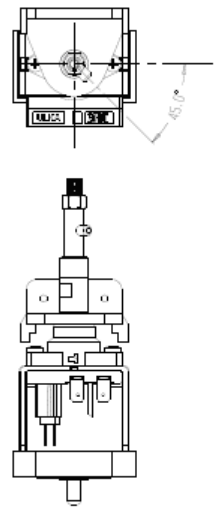

NO.	P-PRT NO.	P-PRT NAME	MATERIAL	QTY
1	03-1123-C	IMP J/B -D-PREP	BRASS/MS9	1
2	00-3624	LOCUTITE WASHER	---	0.56
3	50-8003	22 ANTICAVITATION VALVE	WVA	1
4	45-6177	SILICON O RING	SILICON	2
5	45-6098	WATER PUMP UPPER P-0	PUBEEP	1
6	50-4003	WATER_PUMP	WVA EPS	1
7	03-3008	CABLE TIE	NYLON	1
8	45-6097	WATER PUMP LOWER P-0	PUBEEP	1
9	17-12160-19	WIPE Assy	18# WIPE	1
10	56-9017	PUMP THERMOSTAT 1/5 DEG/SEC	---	1
11	17-11070-18	WIPE Assy	18# WIPE	2
12	36-1006	CLOSED END CONNECTOR H-03 (OSC 600)	---	2
13	01-1066-130	SILICON PUBEEP TUBE	SILICONE	1

REVISED BY	17-8627	DATE	LC	LCY	IN
PART NO.	17-8627	DESIGNED BY			
ENGINEER	WATER PUMP	DRAWN BY			
MATERIAL	---	CHECKED BY			
PRICE	---	APPROVED BY			
FILE NO.	17-8627_00_070518				
		S.E.W Corporation LTD.			

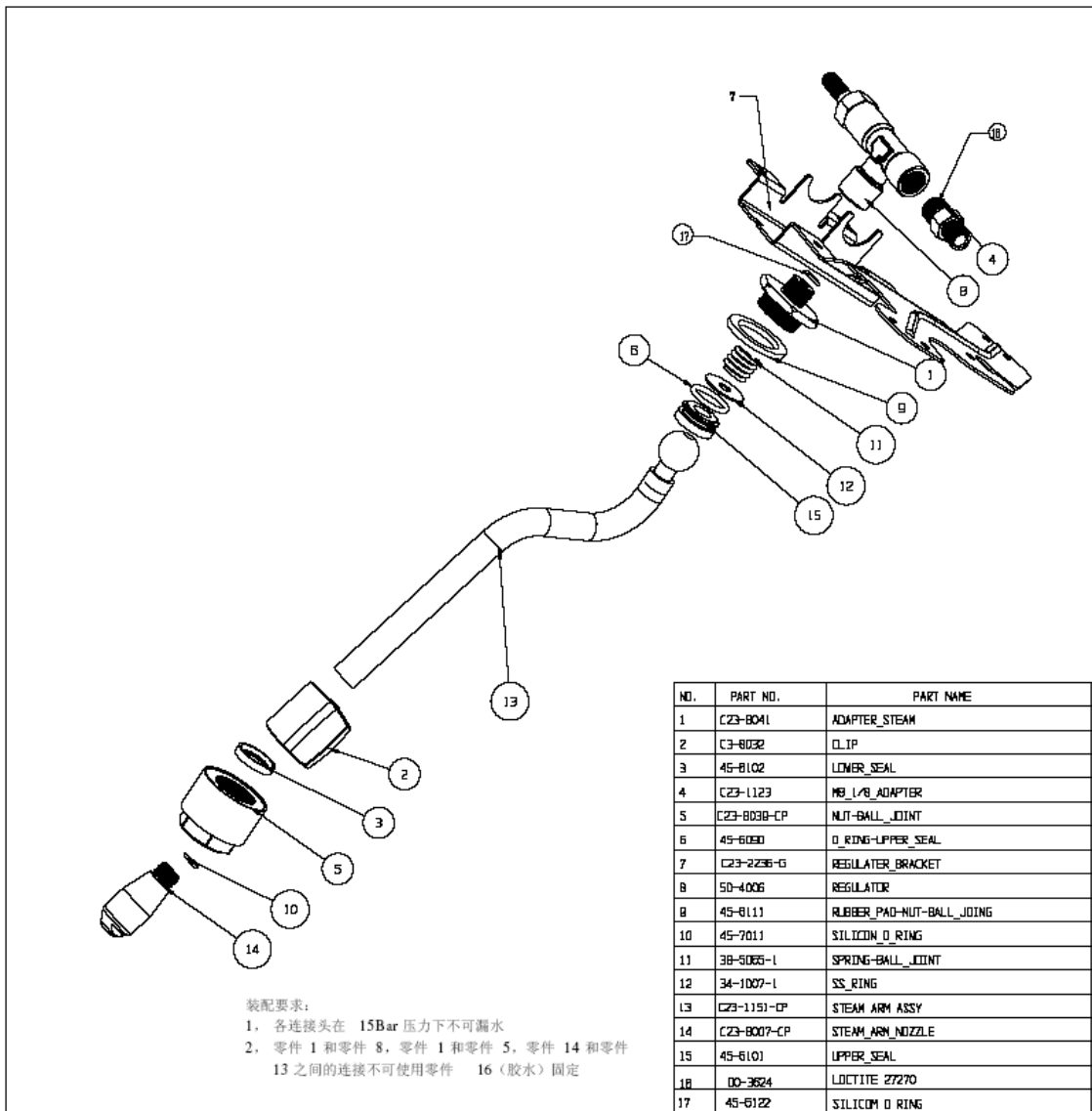

装配要求:  
 1. 各连接头在 15Bar 压力下不可漏水  
 2. 零件 1 和零件 8, 零件 1 和零件 5, 零件 14 和零件 13 之间的连接不可使用零件 16 (胶水) 固定

REVISION				
Mark	Description	Initiated by	Approved by	Date
A	PULLDOWN RELEASE			

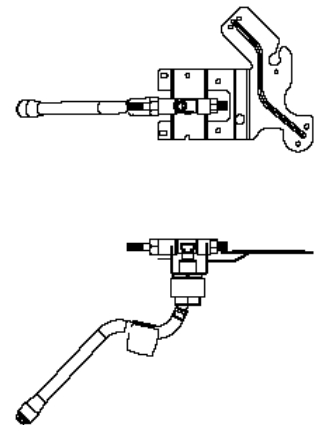

NO.	PART NO.	PART NAME	MATERIAL	QTY
1	C23-8041	ADAPTER_STEAM	BRASS HB3	1
2	C3-8032	CLIP	PA66-50 KUREA	1
3	45-8102	LOWER SEAL	TEFLON 804-5 O-RING	1
4	C23-1123	MB_LVB_ADAPTER	BRASS HB3	1
5	C23-8038-CP	NUT-BALL_JOINT	BRASS HB3 CHROME PLATED	1
6	45-6080	O_RING-UPPER SEAL	VITON 804-5 O-RING	1
7	C23-2236-G	REGULATOR_BRACKET	S.S. STEEL	1
8	50-4006	REGULATOR	BRASS HB3	1
9	45-8111	RUBBER_PAD-NUT-BALL_JOINT	TEFLON 804-5 O-RING	1
10	45-7011	SILICOM O_RING	SILICOM	1
11	38-5065-1	SPRING-BALL_JOINT	SUS 304	1
12	34-1007-1	SS_RING	SUS 304	2
13	C23-1151-CP	STEAM_ARM_ASSY	BRASS HB3 CHROME PLATED	1
14	C23-8007-CP	STEAM_ARM_NOZZLE	BRASS HB3 CHROME PLATED	1
15	45-6101	UPPER SEAL	TEFLON 804-5 O-RING	1
16	00-3624	LOCTITE 27270	---	0.16
17	45-6122	SILICOM O_RING	SILICOM	1

DOCUMENT NO.	18-8107	SCALE	3:10	UNIT	mm
PART NO.	18-8107	DESIGNED BY	DATE	KIANG 28/08/06	
DRAWING OR PART NAME	HOT WATER ARM ASSY	DRAWN BY	DATE	KIANG 28/08/06	
MATERIAL	---	CHECKED BY	DATE	ROBERT 28/09/06	
FINISH	---	APPROVED BY	DATE	ROBERT 28/09/06	
FILE DIR	18-8107_DD_080830				
			G.E.W Corporation LTD.		

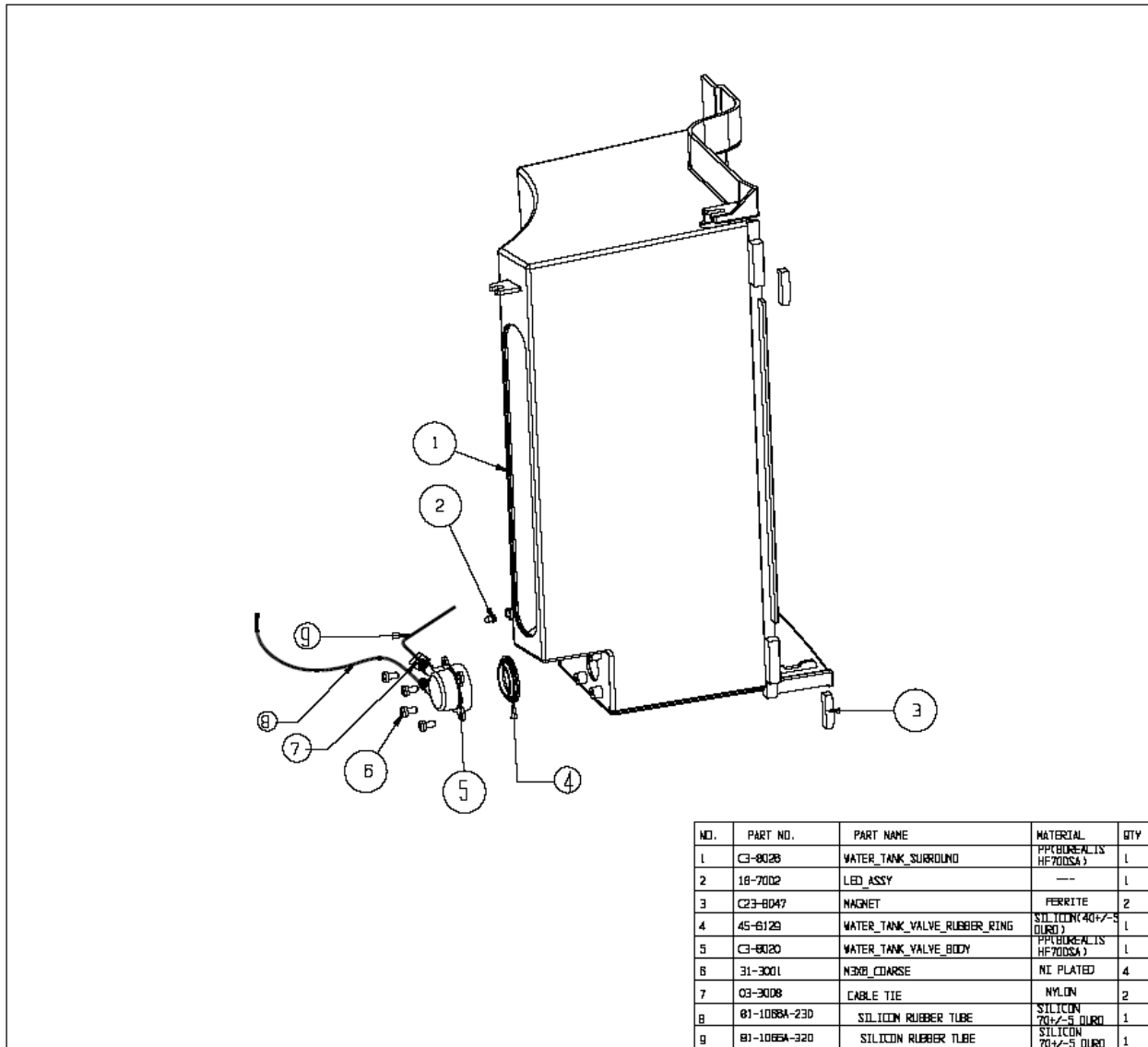

REVISION				
Mark	Description	Initiated by	Approved by	Date
△	PULLDOWN RELEASE			

装配要求:  
 1. 零件 8 和 9 必须装配在零件 1 上的槽内, 并且装配好后要用热熔胶固定。  
 2. 零件 2 必须正确地装配在零件 1 上的圆环内, 不可倾斜或凸出

NO.	PART NO.	PART NAME	MATERIAL	QTY
1	C3-8028	WATER_TANK_SURROUND	PP(CHLORALIS HF70D5A)	1
2	18-7002	LED_ASSY	---	1
3	C23-8047	MAGNET	FERRITE	2
4	45-8129	WATER_TANK_VALVE_RUBBER_RING	SILICON 70+/-5 DURO	1
5	C3-8020	WATER_TANK_VALVE_BODY	PP(CHLORALIS HF70D5A)	1
6	31-3001	MESH_COARSE	NI PLATED	4
7	03-3008	CABLE_TIE	NYLON	2
8	81-1088A-23D	SILICON RUBBER TUBE	SILICON 70+/-5 DURO	1
9	81-1088A-32D	SILICON RUBBER TUBE	SILICON 70+/-5 DURO	1

DRAWING NO.	18-8108	SCALE	1:2	UNIT	mm
PART NO.	18-8108	DESIGNED BY		KWG 28/09/06	
DRAWING OR PART NAME	WATER TANK SURROUND ASS'Y	DRWN BY		KWG 28/09/06	
MATERIAL	---	CHECKED BY		ROBT 28/09/06	
FINISH	---	APPROVED BY		ROBT 28/09/06	
FILE DIR	18-8108_00_06030				
			 G. E. W Corporation LTD.		

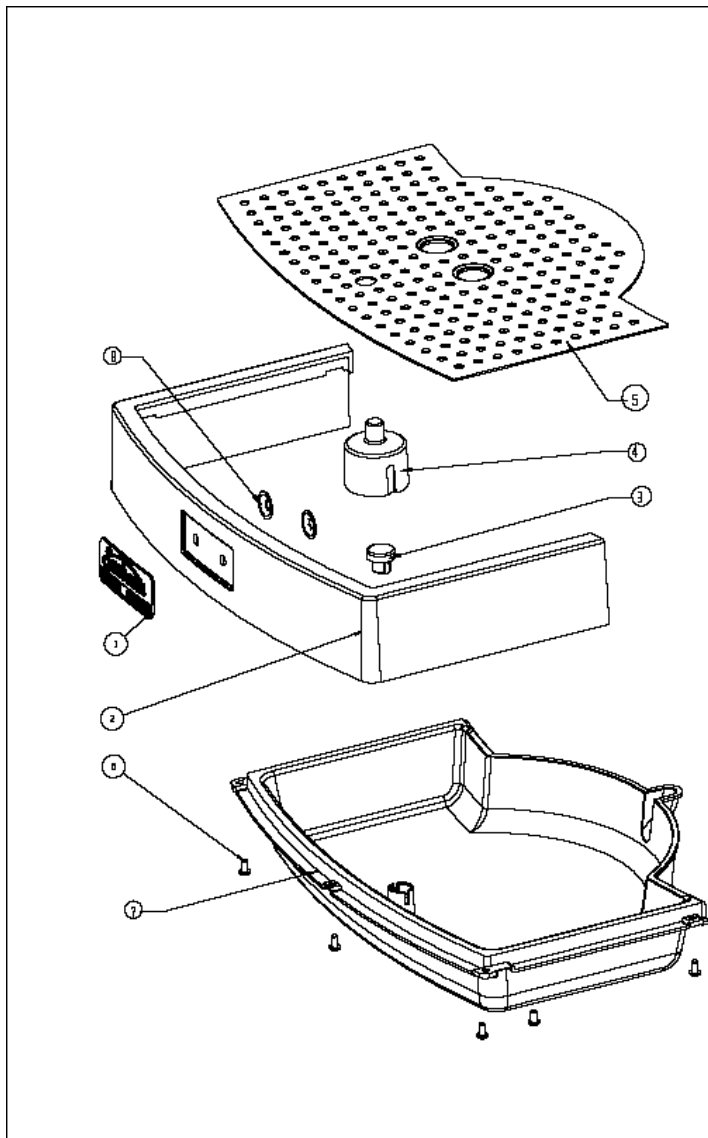

REVISION				
Mark	Description	Initiated by	Approved by	Date
A	FUNCTION RELEASE			

装配要求:  
 1. 零件 1 装配后不可松动。  
 2. 零件 3 装配要求紧密配合, 不可轻易松动

NO.	PART NO.	PART NAME	MATERIAL	QTY
1	20-2033	BRIDGE	2P ZINC CASTING	1
2	C24-1109	DRIP-TRAY-SURROUND	AL CASTING& 300	1
3	C3-9020	DRIP-TRAY COVER	PPRORONALIS HPT0651	1
4	C3-9021	DRIP-TRAY FLOAT	PPRORONALIS HPT0651	1
5	C23-2008	DRIP-TRAY PLATE	SUS 430	1
6	31-1202	M3 6 FLAT	SUS 304	5
7	C3-6025	DRIP-TRAY	PPRORONALIS HPT0651	1
8	34-7016	SELF-LOCK WASHER	SUS 304	2

DRAWING NO.	18-8110	SCALE	1:2	UNIT	mm
PART NO.	18-8110	DESIGNED BY	KGW	DATE	25/05/06
DRAWING OR PART NAME	DRIP-TRAY ASS'Y	DRAWN BY	KGW	DATE	25/05/06
MATERIAL	---	CHECKED BY	ROBERT	DATE	25/05/06
FINISH	---	APPROVED BY	ROBERT	DATE	25/05/06
FILE DIR	18-8110_00_060830				
				G.E.W Corporation LTD.	

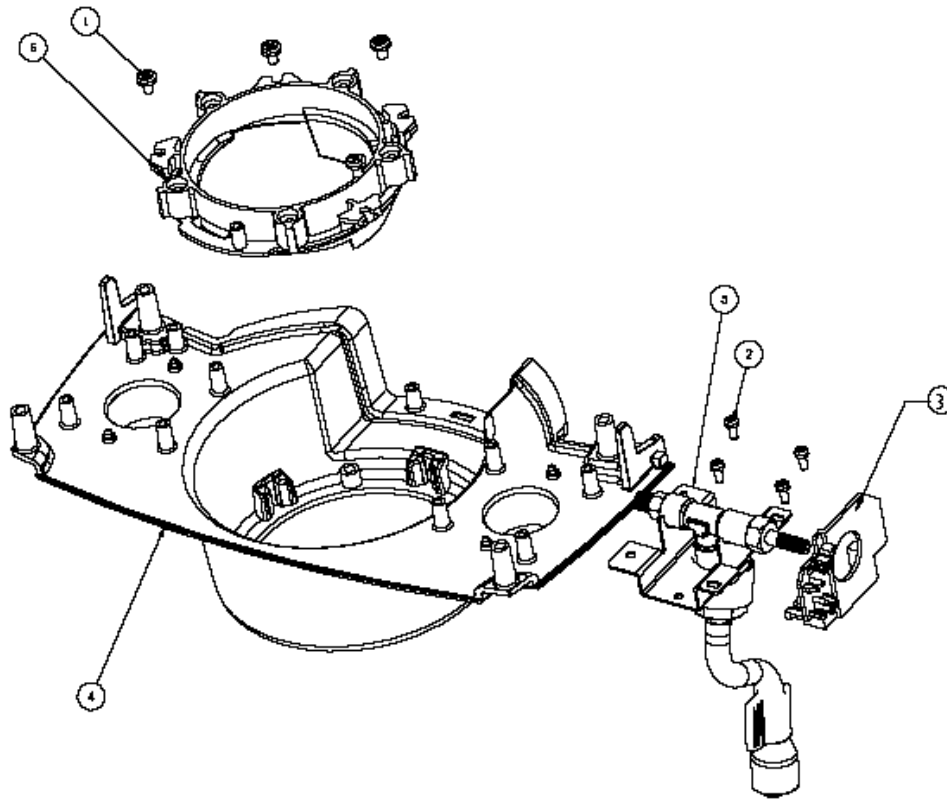

NO.	PART NO.	PART NAME	MATERIAL	QTY
1	31-1086	HA 6	NI PLATED	4
2	31-1141	HEX W WASHER	NI PLATED	4
3	C3-9003	DIAL-BRACKET	PA66-G30 KINFA	1
4	C24-1100	FRONT CASTING	AL CASTING(A 300)	1
5	17-8635	HOT WATER ARM ASSY	—	1
6	C24-3102-CP	SHOWER HEAD COLLAR	AL CASTING(A 300)	1

DRAWING NO.	18-8111
PART NO.	18-8111
DRAWING OR PART NAME	FRONT CASTING ASS'Y
MATERIAL	—
FINISH	—
FILE DIR	18-8111_D0_DEK



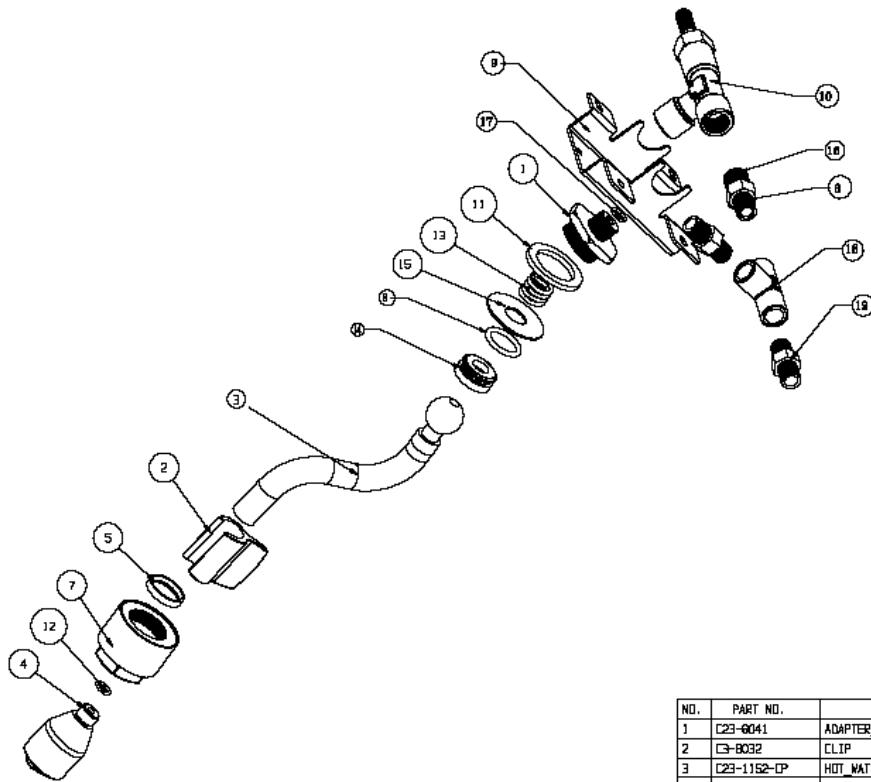

装配要求:  
 1. 各接头在 15Bar 压力下不可漏水  
 2. 零件 1 和零件 10, 零件 4 和零件 3 之间的连接不可使用零件 16 (胶水) 固定

REVISION				
Mark	Description	Initiated by	Approved by	Date
A	PUBLICATION			

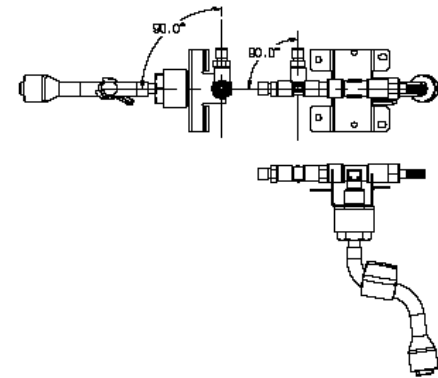

NO.	PART NO.	PART NAME	MATERIAL	QTY
1	C23-6041	ADAPTER_STEAM	BRASS (Z360)	1
2	C3-8032	CLIP	PA66-3300	1
3	C23-1152-CP	HOT WATER ARM	BRASS (Z360)	1
4	C23-1126-CP	HOT WATER SHOWER HEAD	BRASS (Z360)	1
5	45-8102	LOWER SEAL	EPDM	1
6	C23-1123	MB 1/8 ADAPTER	BRASS (Z360)	1
7	C23-8039-CP	NUT-BALL JOINT	BRASS (Z360)	1
8	45-8080	O RING-UPPER SEAL	EPDM	1
9	C23-7456-G	REGULATOR BRACKET	ALUMINUM	1
10	50-400B	REGULATOR	ALUMINUM	1
11	45-8111	RUBBER PAD-NUT-BALL JOINT	EPDM	1
12	45-7011	SILICON O RING	EPDM	1
13	39-5065-1	SPRING-BALL JOINT	BRASS	1
14	45-8101	UPPER SEAL	EPDM	1
15	34-1007-1	SS RING	BRASS	2
16	00-3624	LOCTITE 27270		0.10
17	45-8122	SILICON O RING	EPDM	1
18	C23-1124	BRASS PART	BRASS (Z360)	1
19	C23-1116	BRASS PART	BRASS (Z360)	2

DOCUMENT NO.	18-8117	SCALE	3:10	UNIT	mm
PART NO.	18-8117	DESIGNED BY DATE	KIANG 28/08/08		
DRAWING OR PART NAME	HOT WATER ARM ASSY	DRAWN BY DATE	KIANG 28/08/08		
MATERIAL	—	CHECKED BY DATE	ROBERT 28/08/08		
FINISH	—	APPROVED BY DATE	ROBERT 28/08/08		
FILE DIR	B1-8117_00_080830				
		G.E.W Corporation LTD.			

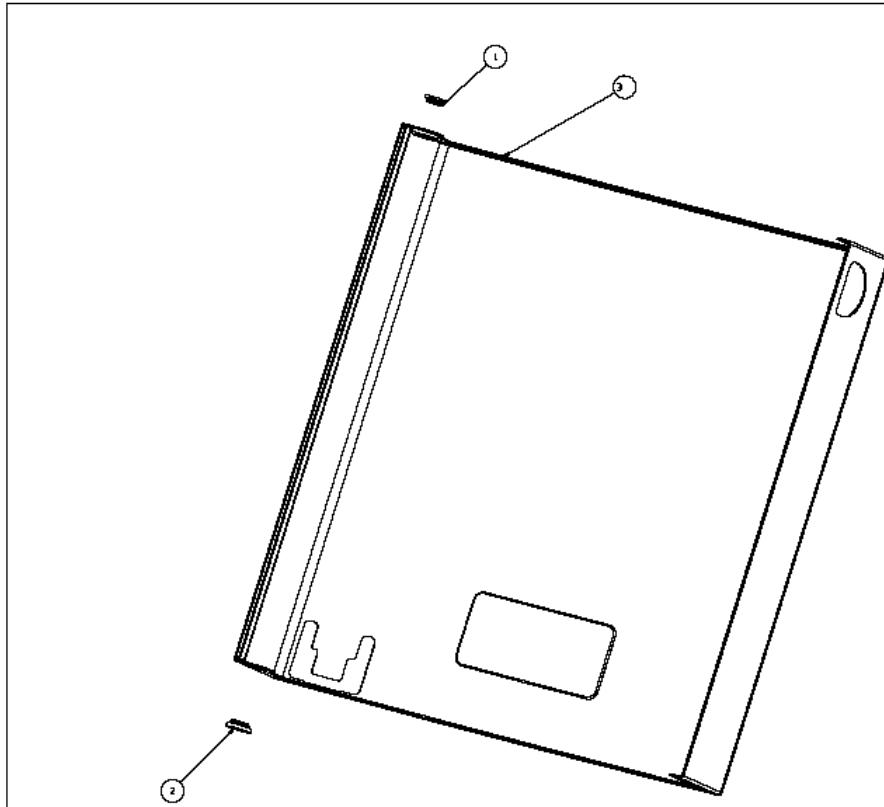

REVISION				
Mark	Description	Initiated by	Approved by	Date
△	PUBLICATION RELEASE			

DOCUMENT NO.	18-8125	SCALE	1:1	UNIT	mm
PART NO.	18-8125	DESIGNED BY	KIANG	29/09/06	
DRAWING OR PART NAME	REAR DOOR ASSY	DRAWN BY	KIANG	29/09/06	
MATERIAL	---	CHECKED BY	ROBERT	29/09/06	
FINISH	---	APPROVED BY	ROBERT	29/09/06	
FILE DIR	18-8125_QD_080930				
				G. E. W Corporation LTD.	

NO.	PART NO.	PART NAME	MATERIAL	QTY
1	C3-8022	UPPER PIVOT CAP	NYLON 66 1300S	1
2	C3-9007	LOWER PIVOT CAP	NYLON 66 1300S	1
3	17-8847	REAR DOOR SPOT WELDING ASSY	---	1

# CIRCUIT DIAGRAM

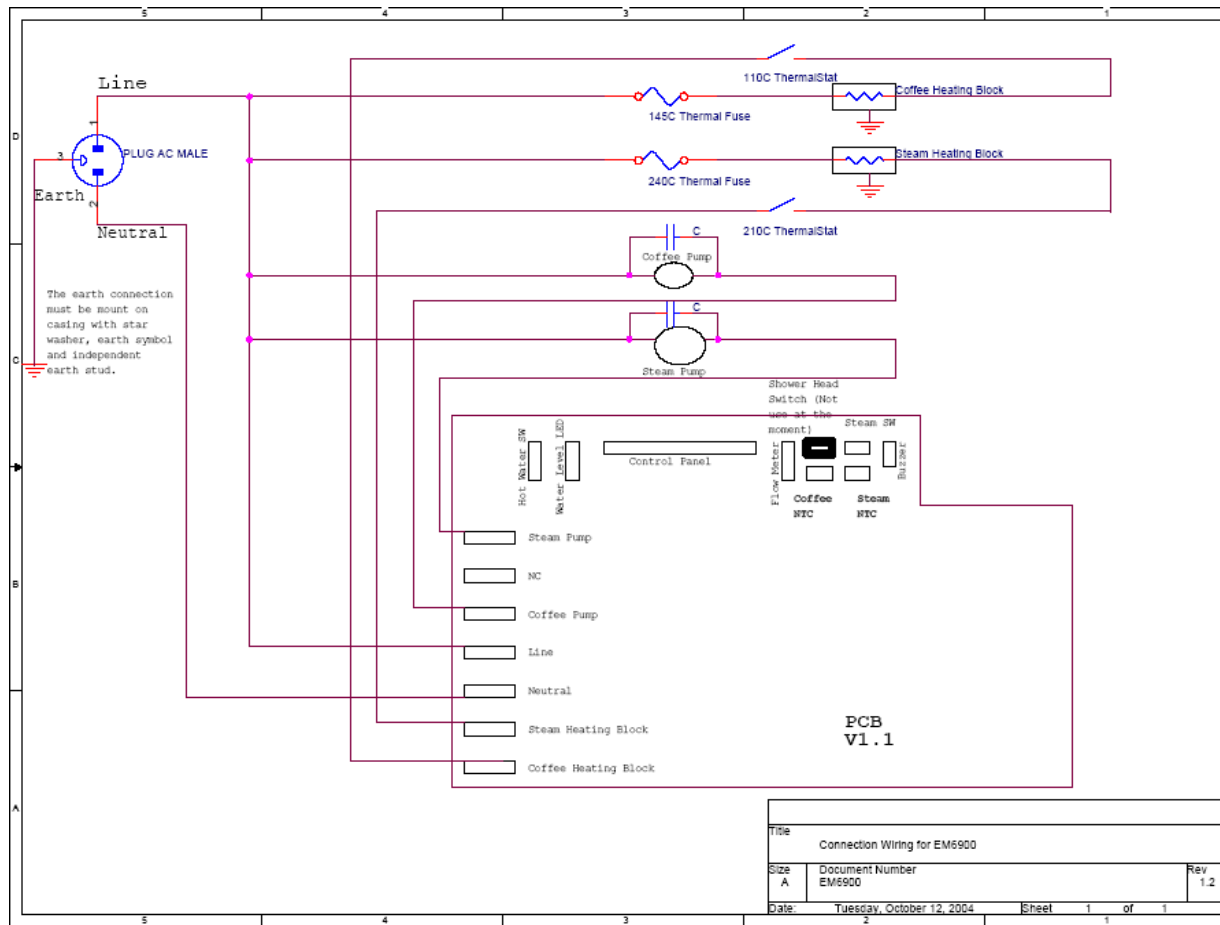

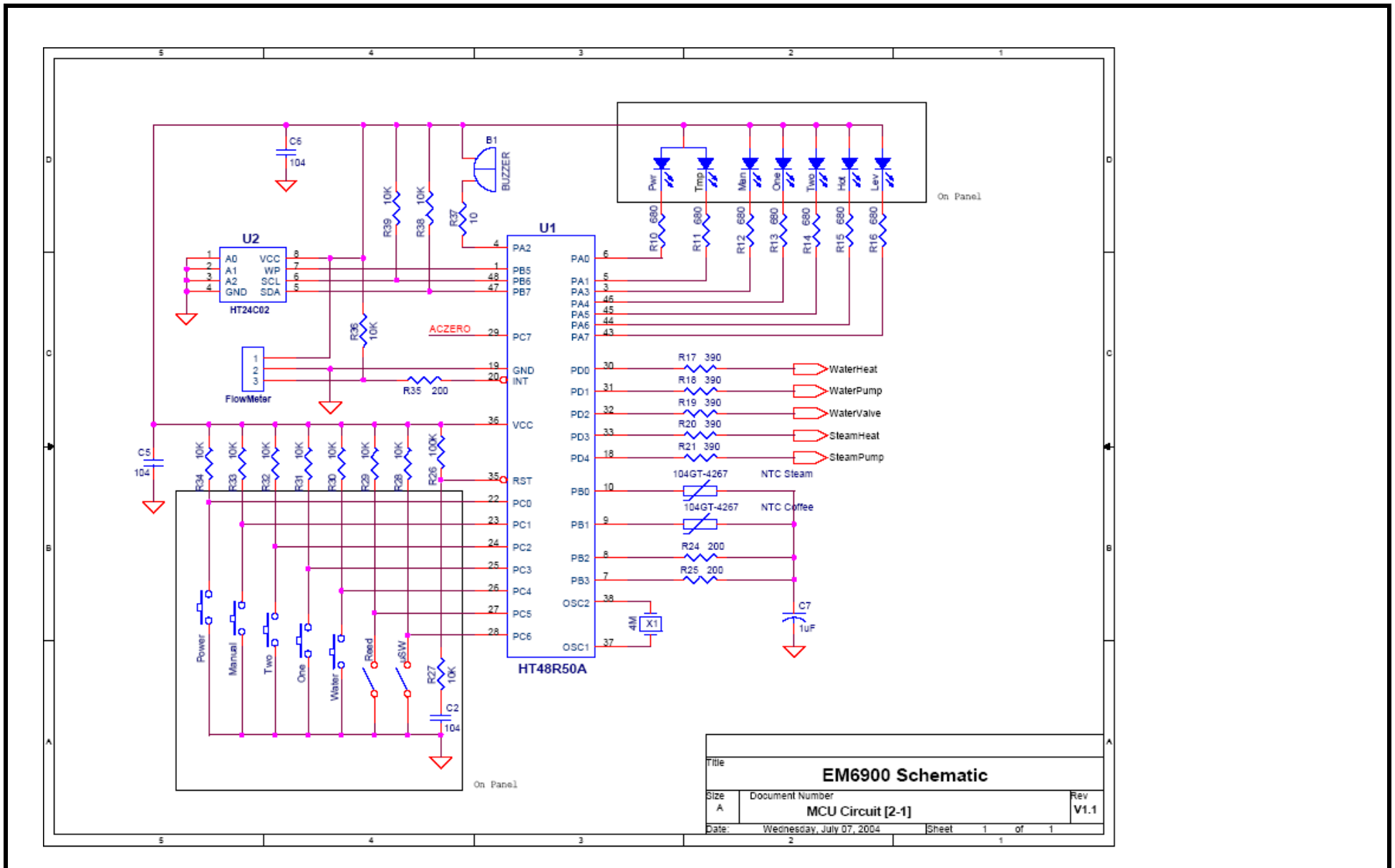

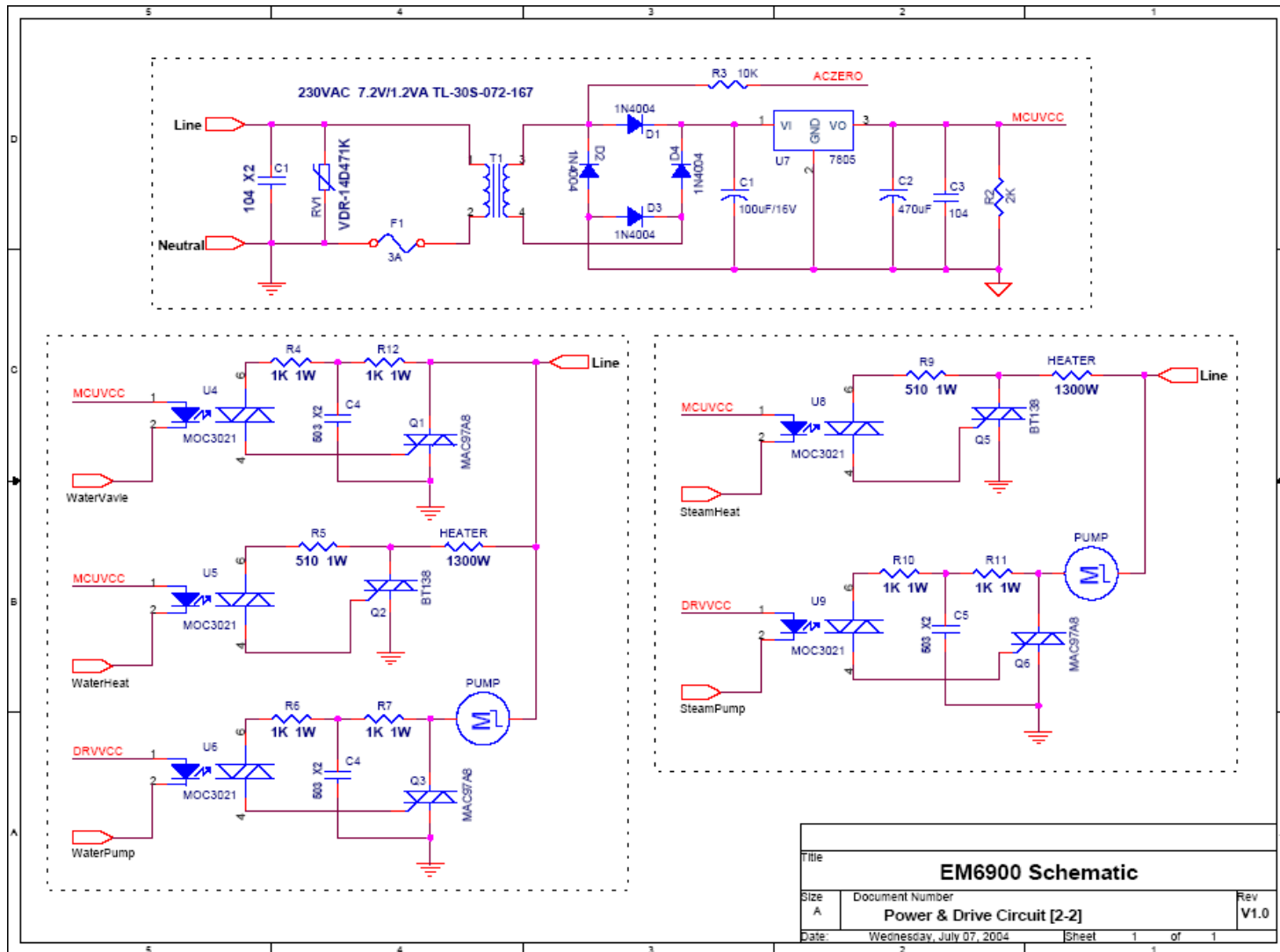

## Free Manuals Download Website

<http://myh66.com>

<http://usermanuals.us>

<http://www.somanuals.com>

<http://www.4manuals.cc>

<http://www.manual-lib.com>

<http://www.404manual.com>

<http://www.luxmanual.com>

<http://aubethermostatmanual.com>

Golf course search by state

<http://golfingnear.com>

Email search by domain

<http://emailbydomain.com>

Auto manuals search

<http://auto.somanuals.com>

TV manuals search

<http://tv.somanuals.com>