

# Telex<sup>®</sup>

---

## User's Manual



## Firefly<sup>™</sup> P350 LCD Notebook Projector

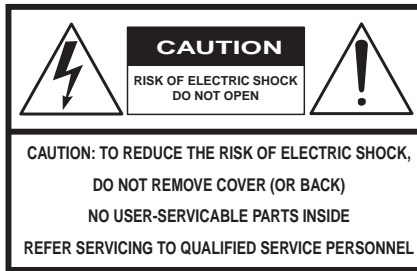

The lightning flash with arrowhead symbol is displayed on the product to alert the user to the presence of uninsulated “dangerous voltage” within the product’s enclosure that may constitute a risk of electric shock.



The exclamation point symbol is displayed on the product to alert the user to the presence of important operating and maintenance (servicing) instructions in the literature that accompanies the product.



The heat warning symbol is displayed on the product to alert the user to the presence of a hot surface that may constitute a risk of burns or fire.

## IMPORTANT SAFETY INSTRUCTIONS

1. Read Instructions - All the safety and operating instructions should be read before the product is operated.
2. Retain Instructions - The safety and operating instructions should be retained for future reference.
3. Heed Warnings - All warnings on the product and in the operating instructions should be adhered to.
4. Follow Instructions - All operating and use instructions should be followed.
5. Cleaning - Unplug the product from the wall outlet before cleaning any exterior surface. Follow the cleaning instructions in this manual.
6. Water and Moisture - Do not use this product near water - for example, near a bathtub, washbowl, kitchen sink, laundry tub, in a wet basement, or near a swimming pool, etc.
7. Ventilation - Slots and openings in the cabinet are provided for ventilation and to ensure reliable operation of the product and to prevent it from overheating. These slots and openings must not be blocked or covered in any manner.

8. Power Cord Protection - Power supply cords should be routed so that they are not likely to be walked on or pinched by items placed upon or against them, paying particular attention to cords at wall outlets, convenience receptacles, and the point where they exit from the product.
9. Lightning - For added protection for this product during a lightning storm, or when it is left unattended and unused for long periods of time, unplug it from the wall outlet. This will prevent damage to the product due to lightning and power-line surges.
10. Overloading - Do not overload wall outlets, extension cords, or integral convenience receptacles as this can result in a risk of fire or electric shock.
11. Object and Liquid Entry - Care should be taken so that objects do not fall and liquids are not spilled onto the product as they may touch dangerous voltage points or short-out parts that could result in a fire or electric shock.
12. Servicing - Do not attempt to service the product beyond that described in the operating instructions as opening or removing covers may expose you to dangerous voltage. All other servicing should be referred to qualified service personnel.
13. Damage Requiring Service - Unplug this product from the wall outlet and refer servicing to qualified service personnel when:
  - a. The power supply cord or the plug has been damaged.
  - b. Objects have fallen, or liquid has been spilled into the product.
  - c. The product has been exposed to rain or water.
  - d. The product does not appear to operate normally or exhibits a marked change in performance.
  - e. The product has been dropped, or the enclosure damaged.
14. Replacement Parts - When replacement parts are required, be sure the technician has used replacement parts that have the same characteristics as the original parts. Unauthorized substitutions may result in fire, electric shock, or other hazards.

## **Warranty**

Telex warrants that the Firefly™ P350 will provide a usable active pixel ratio of at least 99.995%. This means that out of 1.44 million pixels on the Firefly™ P350, less than 50 pixels will be inactive.

Inactive pixels may appear illuminated on the display, however, they will not affect picture quality or the life expectancy of the unit. If you have any questions on this matter, please feel free to contact Telex Communications, Inc.

## **FCC Statement**

This equipment generates, uses, and can radiate radio frequency energy that may cause interference to radio communications if not installed and used in accordance with this manual. The equipment has been tested and found to comply with the limits for a Class A computing device pursuant to Subpart J, Part 15 of FCC Rules which are designed to provide reasonable protection against such interference when operated in a commercial environment. Operation of this equipment in a residential area may cause interference which the user (at their own expense) will be required to correct.

## **Canadian Department of Communications Statement**

This digital apparatus does not exceed the Class A limits for radio noise emissions from digital apparatus as set out in the Radio Interference Regulations of the Canadian Department of Communications.

Le présent appareil numérique émet pas de bruits radioélectriques dépassant les limites applicables aux appareils numériques de la classe A prescrites dans le Règlement sur le brouillage radioélectrique édicté par le Ministère des Communications du Canada.

Firefly™ is a trademark of Telex Communications, Inc.,  
Minneapolis, Minnesota 55420

# TABLE OF CONTENTS

IMPORTANT SAFETY INSTRUCTIONS . . . . .	ii
Warranty . . . . .	iv
FCC Statement . . . . .	iv
Canadian Department of Communications Statement . . . . .	iv
GENERAL FEATURES . . . . .	1
ACCESSORIES . . . . .	3
UNPACKING THE P350 . . . . .	4
P350 SETUP . . . . .	6
Positioning the Firefly™ P350 On the Desktop . . . . .	6
Connecting the P350 . . . . .	6
Remote Control Battery . . . . .	11
OPERATION . . . . .	12
Basic Operation . . . . .	12
CONTROLS . . . . .	15
Keypanel Controls . . . . .	15
Menu Mode On-Screen Controls . . . . .	17
Illuminated Indicators . . . . .	21
Remote Control . . . . .	21
CARE AND MAINTENANCE . . . . .	22
Storage and Transportation . . . . .	22
Lens Cleaning . . . . .	22
Lamp Replacement . . . . .	23
Fuse Replacement . . . . .	24
Troubleshooting Guide . . . . .	25
SERVICE INFORMATION . . . . .	28
TECHNICAL SPECIFICATIONS . . . . .	29
ABBREVIATIONS . . . . .	31
INDEX . . . . .	32

# GENERAL FEATURES

The Firefly™ P350 is a full-color compact LCD projection system that is used to display a computerized multi-media presentation. The built-in amplifier/speakers lets you connect to a wireless microphone, portable CD player, or to the auxiliary output of a stereo system. The P350 also allows you to connect to the output of a VCR or LaserDisc player.

The P350 is equipped with a monitor interface connector. This allows you to simultaneously view your computer video on both the small and large screens. Figure 1 shows the P350 in use to project computer-generated images onto a large screen.

**Figure 1. P350 In Operation**



The Firefly™ P350 can be connected to any IBM or IBM compatible computer equipped with a VGA/SVGA video output. The P350 can also be connected to any Apple Macintosh computer that is equipped with a standard Macintosh video output.

The Firefly™ P350 uses advanced thin-film-transistor liquid crystal display (TFT LCD) technology and is capable of displaying up to 16,194,277 colors. The fast response time of the P350's TFT LCD provides you with the ability to display sharp, clear, fast-moving images.

The P350 liquid crystal display is a matrix of 1.44 million pixels arranged in 600 rows x 800 columns x 3 colors. Each pixel is a single thin-film-transistor that actively controls the brightness of the light that passes through the pixel.

To protect the P350 from excessive heat, it is equipped with several cooling fans. One of these fans is running whenever the P350 is plugged in, the other fans are turned on whenever the LCD notebook projector is turned on.

The keypanel and on-screen controls allow you to change the video source, color, tint, focus, position, etc. of the projected color image; and change the volume and tone of the sound.

# ACCESSORIES

The accessories shown in Figures 2 and 3 are available for use with the Firefly™ P350 LCD notebook projector:

**Figure 2. RC-10 Remote Control**  
Catalog 47436-033

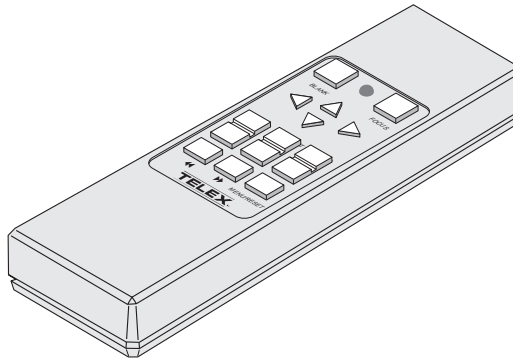

The RC-10 is specifically designed for use with the Firefly™ P350. It allows remote control of all the P350 keypanel and on-screen functions. (The RC-10 comes with the Firefly™ P350.)

**Figure 3. B-10 Lapel Microphone with Transmitter**  
Catalog 70889-xxx

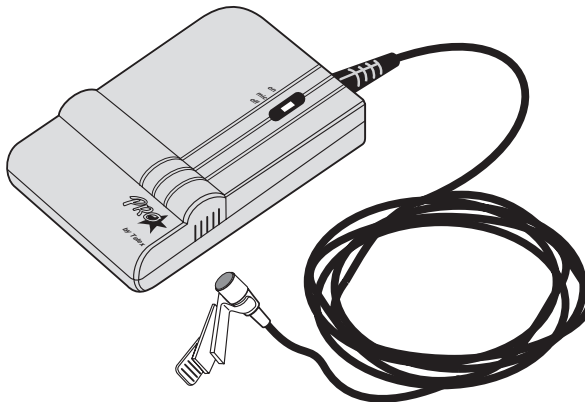

The B-10 features a permanently attached omni-directional lapel microphone. The unique microphone cable doubles as an efficient antenna, and the transmitter can be clipped to your belt or placed in your pocket. The B-10 can be configured for use with either the PAS-1 or ENG-1 Telex receiver.



# UNPACKING THE P350

Unpack the Firefly™ P350 LCD notebook projector and check the package contents. Refer to Figure 4 and the following list for items that are included in the P350:

- P350 LCD notebook projector, with appropriate labels
- User's manual
- Quick reference guide
- Adapter Redemption Card
- VGA/SVGA video cable
- Macintosh adapters for P350 (550093-002 and 550093-003)
- Audio cable (1/8" stereo phone to 1/8" stereo phone)
- Audio cable (dual RCA to 1/8" stereo phone adapter)
- Composite video (RCA to RCA)
- RC-10 Remote control
- Power cord (110V units only)
- Registration card
- Soft-sided case
- Warranty card

Contact your dealer if anything is missing or damaged.



**NOTE:** The 550093-002 and 550093-003 adapters are for use with Macintosh multisync monitors. (Telex part numbers 550093-000 and 550093-001 are for 640 x 480 Macintosh mode, while Telex part numbers 550093-003 and 550093-004 are for 832 x 624 Macintosh mode.)



**NOTE:** If the adapters that came with your P350 do not meet your Macintosh computer requirements, complete and return the Adapter Redemption Card.

# Figure 4. P350 Package Contents

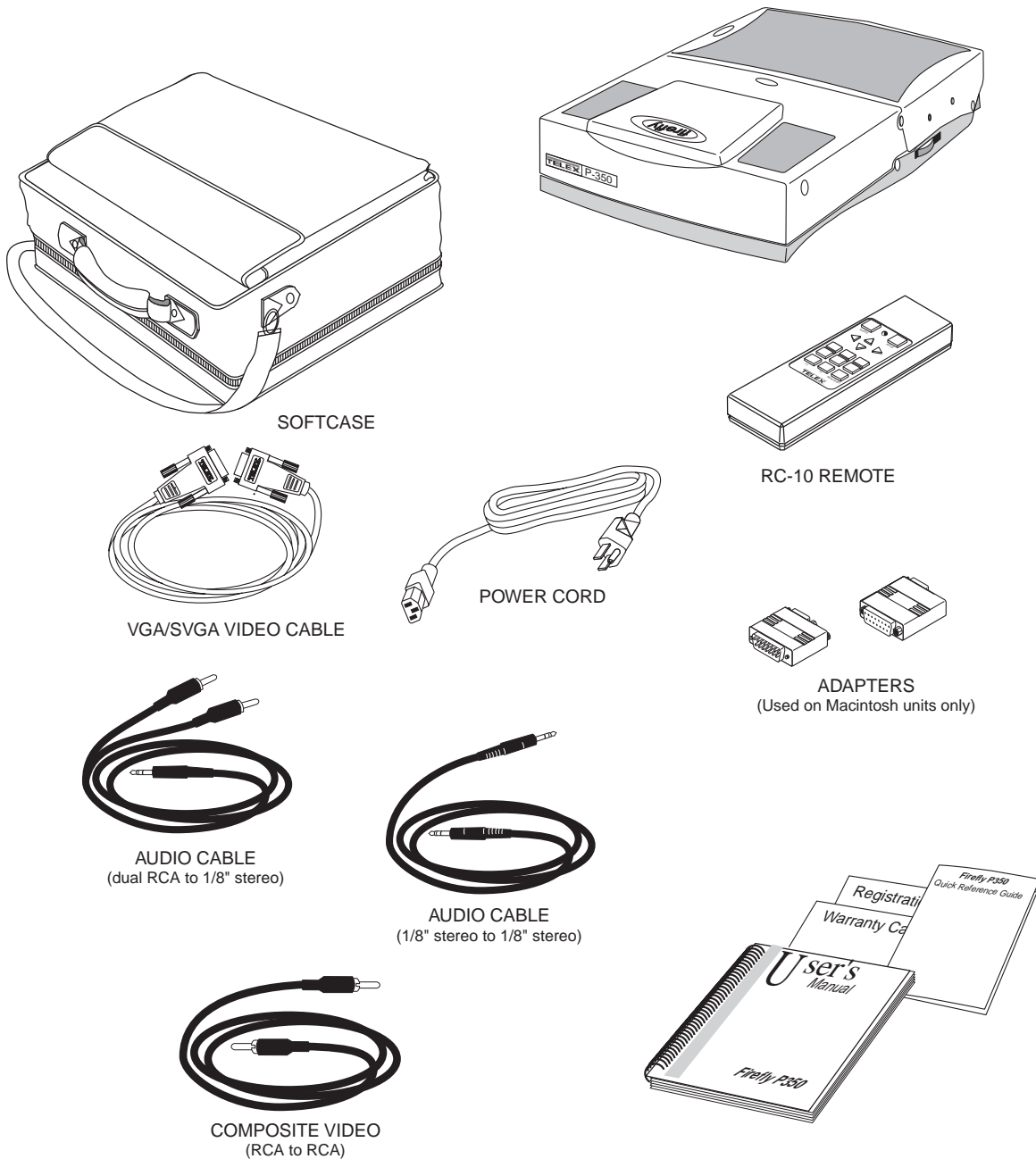

# P350 SETUP

This section is a detailed description of the setup for your P350.

## Positioning the Firefly™ P350 On the Desktop

1. Place the P350 on a table or desktop as shown in Figure 5.



**NOTE:** Ensure that the P350 vents are not blocked. The P350 takes in cool air at the side of the projector. Hot air is exhausted at the rear of the P350.



**WARNING!** To prevent heat damage, keep all materials at least one foot (30 cm) from the rear of the P350.

2. To determine the distance between projector and screen, refer to Figure 5 and select the desired screen image size.

Figure 5. Distance vs Image Size

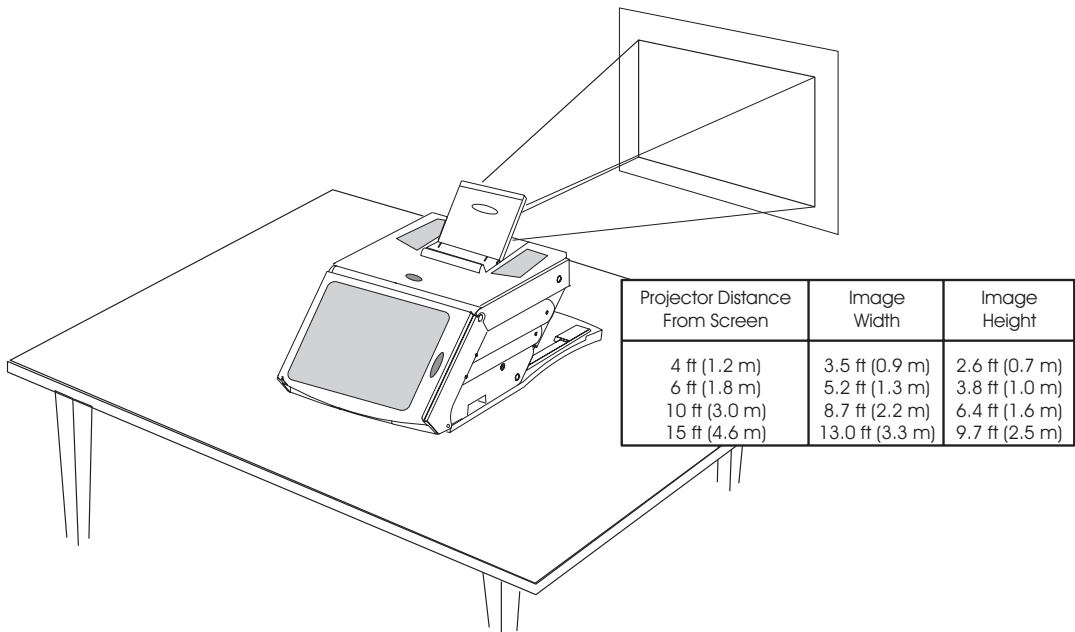

## Connecting the P350

The P350 must be connected to a video source, and to an AC wall outlet. The P350 can be connected to a computer monitor, audio source, additional (composite or S-Video) video source and to an external amplified stereo speaker system.

The following describes the steps needed to connect the P350.

1. Turn off all equipment.
2. Slide the locking mechanism (Figure 6) to release, then lift the P350 to its raised position.
3. Plug the Firefly™ P350 into an AC wall outlet (the *POWER* button will glow and one of the cooling fans will be turned on).
4. Audio input can be amplified by the P350 and heard over the built-in speakers. Connect a stereo or mono audio source, such as the auxiliary output of an amplifier, a wireless microphone system, CD player, tape player, VCR or LaserDisc to the *AUDIO IN* jack (use one of the two audio cables shown in Figure 4).
5. If desired, connect an external amplified, mono or stereo speaker system to the *AUDIO OUT* jack on the P350.



**NOTE:** When a cable is plugged into the *AUDIO OUT* jack, the built-in speakers are disabled.

**Figure 6. Open and Close the Firefly™ P350**

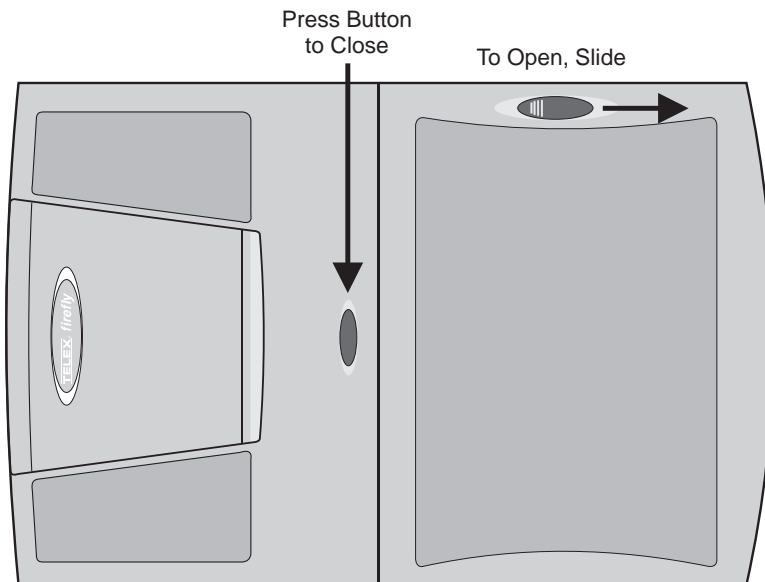

6. If you are using an IBM VGA/SVGA computer, the connections are shown in Figure 7:
- Unplug the monitor cable from the computer.
  - Plug one end of the supplied VGA/SVGA cable into the video port of the computer.
  - Plug the other end of the VGA/SVGA cable into the *COMPUTER* jack on the Firefly™ P350.
  - To use your computer monitor along with your P350, plug the monitor cable into the *MONITOR* jack on the Firefly™ P350.

Figure 7. P350 to IBM Connections

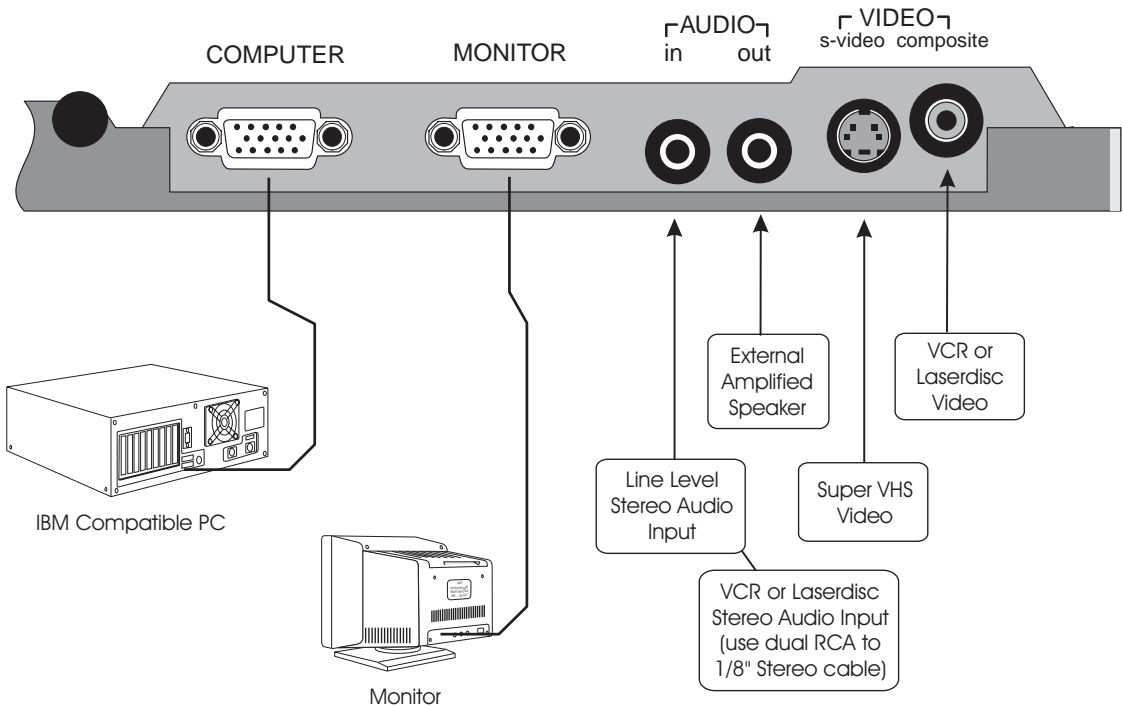

**7. If you are using a Macintosh computer, the connections are shown in Figure 8:**

- a. Unplug the monitor cable from the computer.
- b. Plug the adapter labeled either "550093-0" or "550093-2" into the monitor port of the computer.
- c. Plug one end of the supplied VGA/SVGA cable into the adapter on the computer.
- d. Plug the other end of the VGA/SVGA cable into the *COMPUTER* jack on the Firefly™ P350.
- e. To use your computer monitor along with your Firefly™, select the adapter labeled either "550093-1" or "550093-3." Plug the adapter into the *MONITOR* jack on the Firefly™ P350; plug the computer monitor cable into the adapter.



**NOTE:** Use the "550093-2" and "550093-3" adapters with the 12-inch Macintosh monitor, or the 15-inch Multisync monitor.

**Figure 8. P350 to Macintosh Connections**

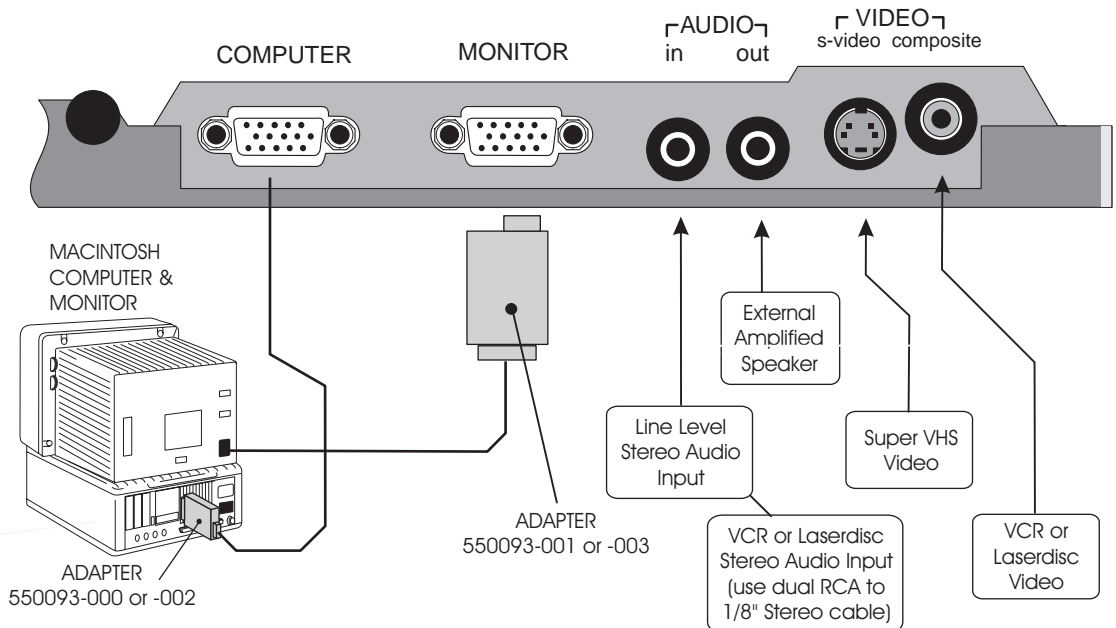

8. A video source such as a VCR or LaserDisc player can be connected to the *VIDEO* and *AUDIO* jacks on the P350 as shown in Figure 9:
  - a. Use the provided composite video cable to connect the VCR or LaserDisc player to the *COMPOSITE* jack on the Firefly™ P350.
  - b. If your video system has S-Video capabilities, use the cable supplied with your video system to connect to the *S-VIDEO* jack on the P350.
  - c. Use the provided dual RCA to 1/8" stereo cable to connect the audio output to the *AUDIO IN* jack on the Firefly™ P350.

**Figure 9. VCR or LaserDisc Connections**

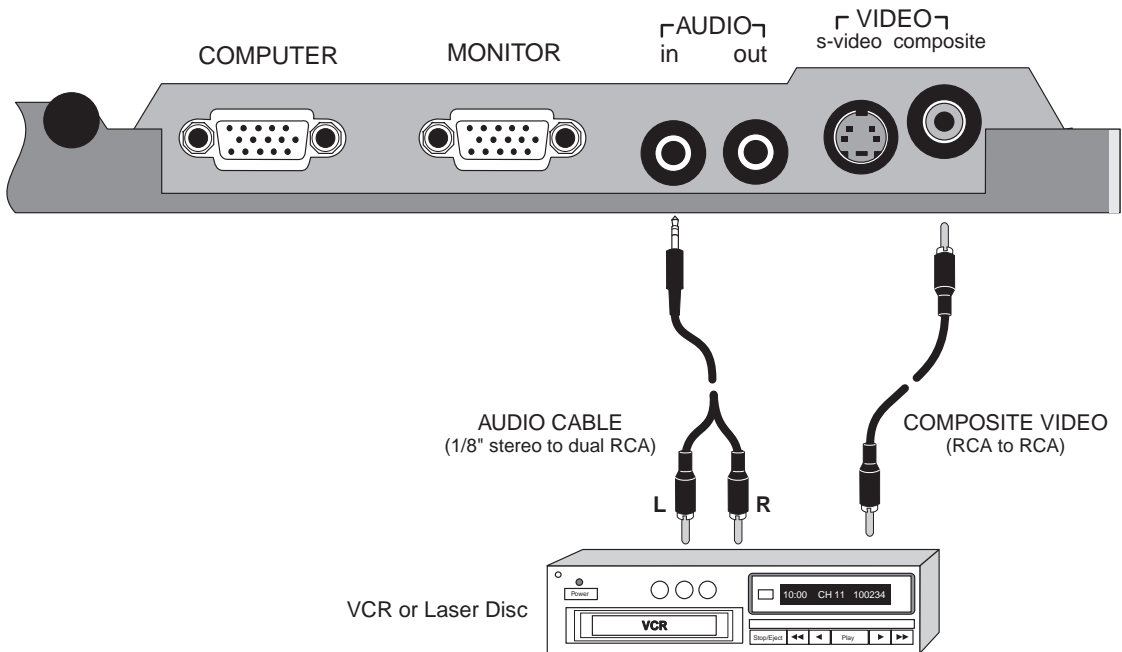

## Remote Control Battery

The remote control requires one 9V alkaline battery installed as shown in Figure 10.

**Figure 10. Remote Control Battery Installation**

1. SLIDE THE BATTERY COVER BACK AND LIFT OUT.

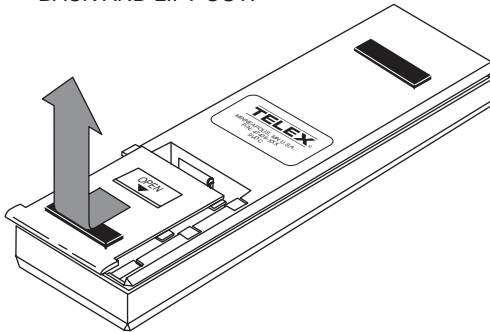

2. PLUG IN THE BATTERY AND POSITION IT IN THE BATTERY COMPARTMENT.

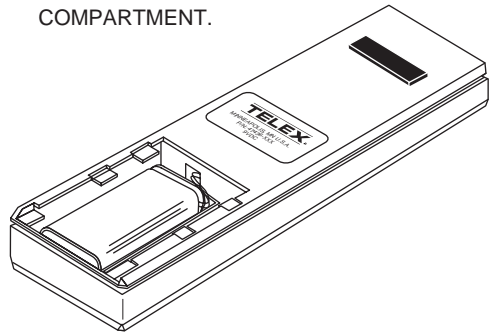

3. ALIGN THE TABS ON THE BATTERY COVER WITH THE SLOTS IN THE BACK CASE AND REPLACE THE COVER.

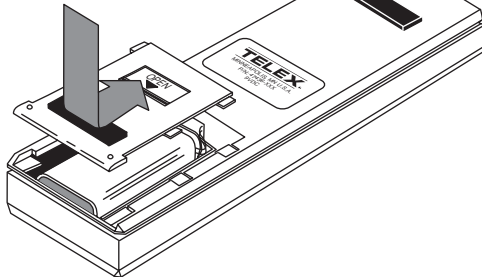

4. CHECK THE OPERATION BY PRESSING ANY KEY. THE LED INDICATOR SHOULD BLINK RAPIDLY.

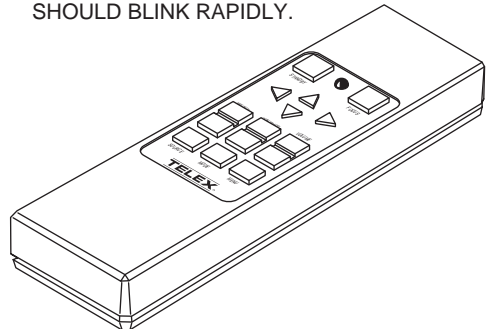

A new battery should be installed in the remote control unit under the following circumstances:

- New remote control unit is received from the factory.
- LED on the remote control no longer lights when keys are pressed, indicating a “dead” battery
- Operating distance between the remote control and the P350 becomes too short for your purposes, indicating a “weak” battery

Continue with the Operation section of this manual for instructions on the use of your Firefly™ P350 LCD Notebook Computer Projector.



# OPERATION

After you have connected the Firefly™ P350 as described in the P350 Setup section of this manual, you are ready to begin using your P350 LCD notebook projector.

## Basic Operation

1. Lift the mirror as shown in Figure 6.
2. Press *POWER* to turn on the P350 LCD notebook projector. The keypanel will light up, the main cooling fans will turn on and the projector lamp will turn on; initially the screen will be blue. After initialization, the Telex logo will appear.



**NOTE:** When the P350 is turned on after a complete cool-down, the lamp will not reach full intensity for approximately one minute of operation.



**WARNING!** To prevent burns when the P350 is operating, avoid touching the lamp access door and the surrounding area.

3. Turn on the attached computer. The Telex logo will disappear and the computer image will appear.



**CAUTION!** The cooling fans protect the Firefly™ P350 from heat generated by the projector lamp. Always make sure that the air intake and exhaust are not blocked.

4. Adjust the room lighting for optimum screen viewing. (The projector lamp is automatically turned on when the P350 is turned on.)
5. Adjust the focus control (Figure 11) and keystone control (Figure 12) for best screen image. (You should now leave the projector and lamp on until your presentation begins.)



**NOTE:** The keypanel and on-screen control settings will be the same as they were when the P350 was last used, if ten seconds were allowed to elapse before the P350 was disconnected from the AC wall outlet.

6. To improve the image phase adjustment, display a colorful image on the computer screen and page to the on-screen **SYNC** control. (It is easier to adjust the Firefly™ P350 with a colorful image.)
7. Turn on your audio source (CD player, wireless microphone, amplifier auxiliary audio output, etc.).

**Figure 11. P350 Screen Focus**

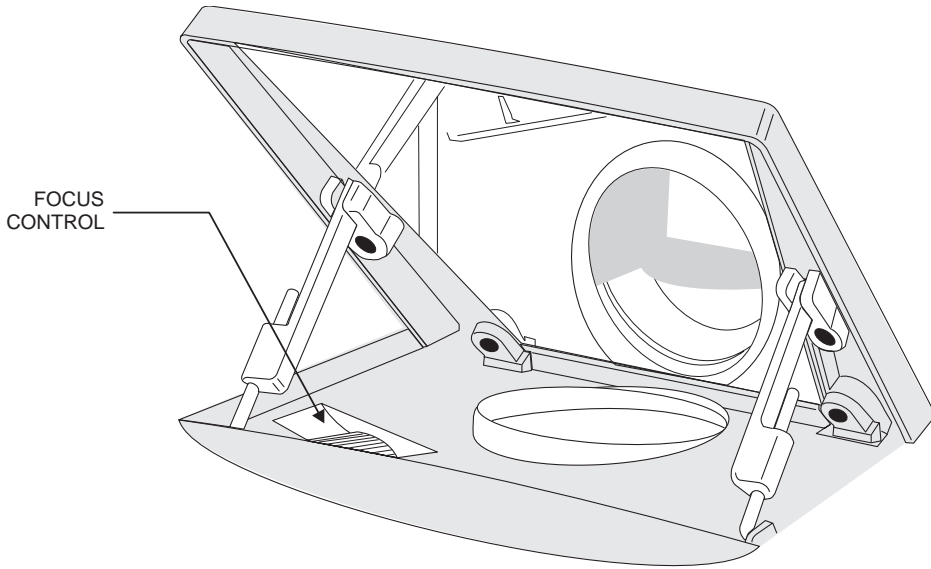

**Figure 12. P350 Keystone Control**

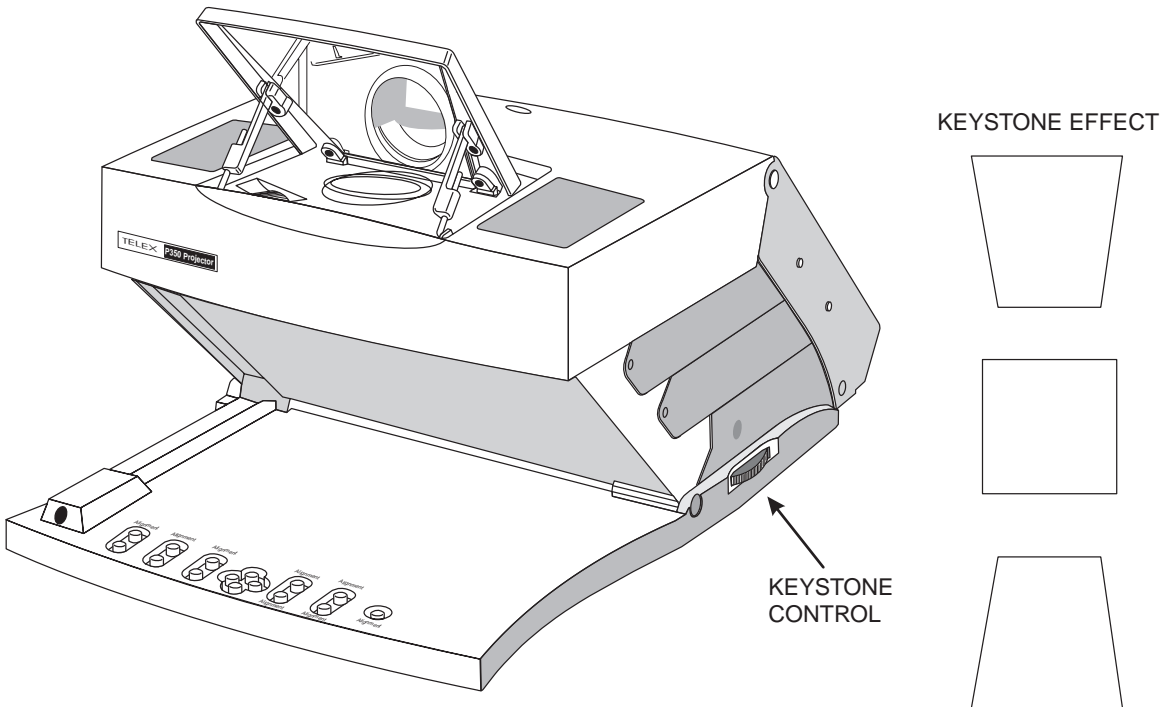

8. Press *VOLUME* to adjust the volume of the P350 built-in speakers.



**NOTE:** If you have an external powered speaker system plugged into the *AUDIO OUT* jack, turn it on and adjust the volume of that external system. (The level at the *AUDIO OUT* jack is controlled by *VOLUME*.)

9. Turn on and play the connected VCR, LaserDisc player, etc.

10. Press *SOURCE* on the P350 keypanel to select one of the video inputs.

11. To further enhance or change the image on the Firefly™ P350, refer to the Keypanel and Menu Mode On-Screen Control sections of this manual.



**NOTE:** To maximize the image quality of NTSC, PAL or SECAM video, the On-Screen controls are displayed in a low resolution mode. When video input is displayed, the On-Screen controls will not appear as sharp as when a computer input is displayed.



**NOTE:** Ten seconds after you make a change, the image enhancements that you have made will be saved. These saved enhancements will be used as the default settings the next time that you activate your P350.

12. When your presentation is complete, press *POWER* to turn off the projector and lamp.



**NOTE:** The lamp may be turned off, then on again before it is allowed to cool completely. However, this action will shorten the life of the lamp.

13. After the Firefly™ P350 has cooled and the main cooling fans have stopped, you may unplug the P350 from the AC wall outlet.



**NOTE:** To use your computer and monitor without disconnecting them from the P350, the P350 must be plugged into an AC wall outlet. The *MONITOR* jack on the Firefly™ P350 requires power to operate the computer monitor.



**NOTE:** The projector does **not** need to be turned on to use the *MONITOR* jack.

# CONTROLS

The P350 keypanel and Menu Mode On-Screen controls allow you to customize the projected image and enhance the appearance of your presentation. The function of each keypanel and on-screen control is described below and the keypanel is shown in Figure 13.

Figure 13. Firefly™ P350 Keypanel

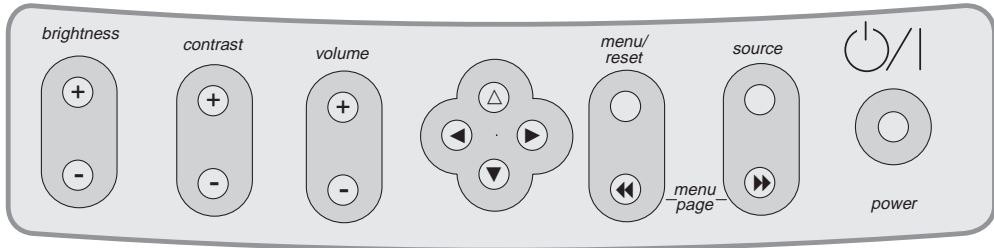

## Keypanel Controls



**NOTE:** All controls have on-screen graphics to indicate their relative value or selection setting.

### *BRIGHTNESS*

Press the upper (+) button of the *BRIGHTNESS* control to increase the overall image brightness. Press the lower (-) button of the *BRIGHTNESS* control to decrease the overall image brightness. When either adjustment limit is reached, the on-screen indicator will stop moving.

### *CONTRAST*

Press the upper (+) button of the *CONTRAST* control to make the color image more vivid. Press the lower (-) button of the *CONTRAST* control to provide greater definition to the color image in the subtle shading areas. When either adjustment limit is reached, the on-screen indicator will stop moving.

### *VOLUME*

Press the upper (+) button of the *VOLUME* control to increase the volume of the built-in speakers, or increase the level at the *AUDIO OUT* jack. Press the lower (-) button of the *VOLUME* control to decrease the volume of the built-in speakers, or decrease the level at the *AUDIO OUT* jack. When either adjustment limit is reached, the currently active on-screen indicator will stop moving.

### Alignment

Press ◀ (left), ▶ (right), △ (up), or ▼ (down) to move the image left, right, up, or down. (There is no adjustment limit for the alignment function; the image will continue moving and wrap around to the opposite edge of the display.)



**NOTE:** The Alignment controls are functional only when the P350 is not in “menu” mode.

#### *MENU*

This key controls the display of the on-screen control “menus.” If an on-screen controls “menu” item is displayed, pressing this key will make the display disappear (on-screen displays normally disappear after five seconds). To enter “menu” mode and display the first page of on-screen controls, press and release *MENU/RESET*, then press either the page-up or page-down double-arrow key to “step” through the “menus” until the desired On-Screen Control page is displayed.

#### *RESET*

To reset the Firefly™ P350 image to the original factory settings, press and hold *MENU/RESET* until the on-screen display indicates **READY TO RESET** (approximately five seconds). When the key is released the P350 will reset, clearing all image enhancements that you have made, restoring the factory settings as the default settings. (If *MENU/RESET* is released before **READY TO RESET** is displayed, the factory settings will not be restored.)

#### *SOURCE*

Press *SOURCE* to select video input from *COMPUTER*, *VIDEO*, *S-VIDEO* jacks. If only one video source is “live,” the screen will go blank for a moment, then return control to the “live” video source.

#### *MENU/PAGE*

The *MENU/PAGE* keys are used to step through the On-Screen control pages. Each subsequent press of one of the *MENU/PAGE* double-arrow keys will display another page of On-Screen controls. The ◀◀ (page-up) and ▶▶ (page-down) keys may be used at any time.

#### *POWER*

Press *POWER* to turn off the projector and lamp. Press *POWER* again to turn on the projector and lamp.

## Menu Mode On-Screen Controls



**NOTE:** To maximize the image quality of NTSC, PAL or SECAM video, the On-Screen controls are displayed in a low resolution mode. When video input is displayed, the On-Screen controls will not appear as sharp as when a computer input is displayed.

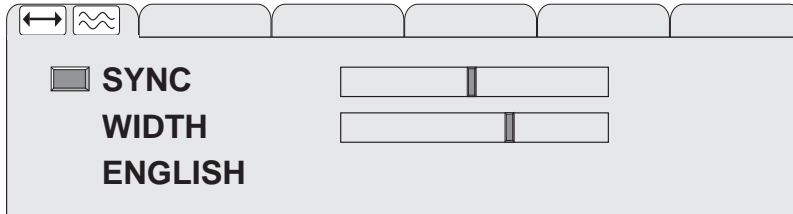

### **SYNC**

To access the menu page with the **SYNC** function, press and release **MENU**, page-up or page-down, then press either the up or down arrow key to “step” to the line where **SYNC** is displayed. Press either the right or left arrow key to select between 16 possible image phase adjustment settings. An on-screen graphic will indicate the **SYNC** setting. **SYNC** can be affected by the **WIDTH** control, refer to the Troubleshooting Guide.

### **WIDTH**

To access the menu page with the **WIDTH** function, press and release **MENU**, page-up or page-down, then press either the up or down arrow key to “step” to the line where **WIDTH** is displayed. Press the right arrow key to expand the width of the image. Press the left arrow key to contract the width of the image. An on-screen graphic will indicate the relative value of the **WIDTH** setting. **WIDTH** may affect the **SYNC** control, refer to the Troubleshooting Guide.

### Language

To access the menu page with the language function, press and release **MENU**, page-up or page-down, then press either the up or down arrow key to “step” to the line where **ENGLISH**, **FRANCAIS**, **DEUTSCH** or **ESPAÑOL** is displayed. Press either the right or left arrow key to “step” through the four languages. The language selected will be displayed on-screen.

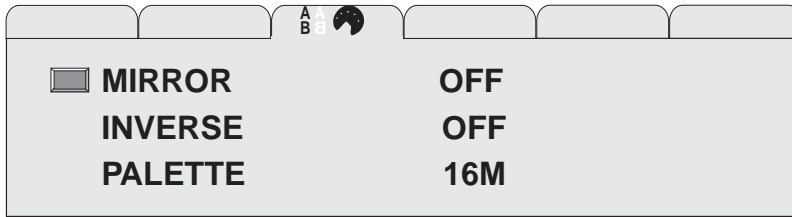

**MIRROR**

To access the menu page with the **MIRROR** function, press page-down two times or page-up five times, then press either the up or down arrow key to “step” to the line where **MIRROR** is displayed. Press either the right or left arrow key to switch between the standard or mirror (reverse) image. An on-screen graphic will indicate the **MIRROR** setting.

**INVERSE**

To access the menu page with the **INVERSE** function, press page-down two times or page-up five times, then press either the up or down arrow key to “step” to the line where **INVERSE** is displayed. Press either the right or left arrow key to switch between a positive and negative image. An on-screen graphic will indicate the **INVERSE** setting.

**PALETTE**

To access the menu page with the **PALETTE** function, press page-down two times or page-up five times, then press either the up or down arrow key to “step” to the line where **PALETTE** is displayed. Press either the right or left arrow key to switch between one of two color modes: 8-color or 16,194,277-color. An on-screen graphic will indicate the **PALETTE** setting.

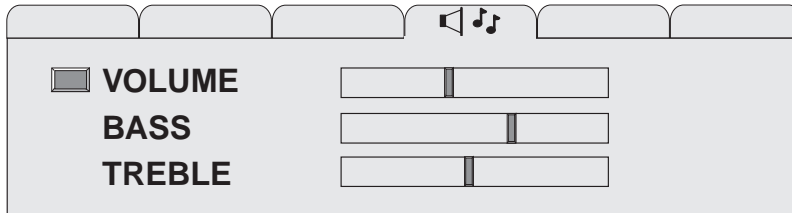

**VOLUME**

To access the menu page with the **VOLUME** function, press page-down three times or page-up four times, then press either the up or down arrow key to “step” to the line where **VOLUME** is displayed. Press the right arrow key to increase the volume of the built-in speakers, or increase the level at the **AUDIO OUT** jack. Press the left arrow key to decrease the volume of the built-in speakers, or decrease the level at the **AUDIO OUT** jack. An on-screen graphic will indicate the relative value of the **VOLUME** setting.

## **BASS**

To access the menu page with the **BASS** function, press page-down three times or page-up four times, then press either the up or down arrow key to “step” to the line where **BASS** is displayed. Press the right arrow key to increase the low tones in the speaker output. Press the left arrow key to decrease the low tones in the speaker output. An on-screen graphic will indicate the relative value of the **BASS** setting.

## **TREBLE**

To access the menu page with the **TREBLE** function, press page-down three times or page-up four times, then press either the up or down arrow key to “step” to the line where **TREBLE** is displayed. Press the right arrow key to increase the high tones in the speaker output. Press the left arrow key to decrease the high tones in the speaker output. An on-screen graphic will indicate the relative value of the **TREBLE** setting.

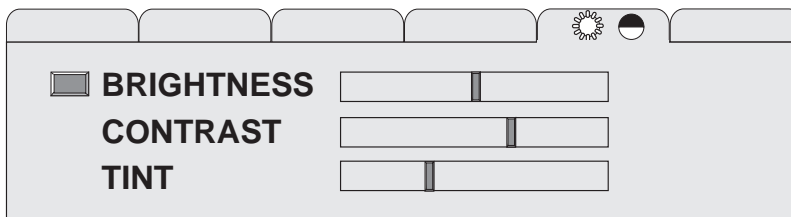

## **BRIGHTNESS**

To access the menu page with the **BRIGHTNESS** function, press page-down four times or page-up three times, then press either the up or down arrow key to “step” to the line where **BRIGHTNESS** is displayed. Press the right arrow key to increase the overall image brightness. Press the left arrow key to decrease the overall image brightness. An on-screen graphic will indicate the relative value of the **BRIGHTNESS** setting.

## **CONTRAST**

To access the menu page with the **CONTRAST** function, press page-down four times or page-up three times, then press either the up or down arrow key to “step” to the line where **CONTRAST** is displayed. Press the right arrow key to make the color image more vivid. Press the left arrow key to provide greater definition to the color image in the subtle shading areas. An on-screen graphic will indicate the relative value of the **CONTRAST** setting.

## **TINT**

To access the menu page with the **TINT** function, press page-down four times or page-up three times, then press either the up or down arrow key to “step” to the line where **TINT** is displayed. Press the right arrow key to increase the red in the color image. Press the left arrow key to increase the green in the color image. An on-screen graphic will indicate the relative value of the **TINT** setting. This control can only be adjusted when viewing a computer video image.



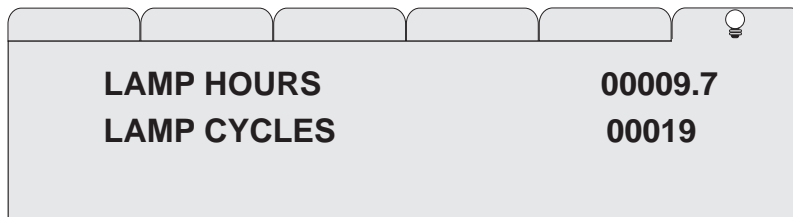

### **LAMP HOURS**

To access the menu page with the **LAMP HOURS** function, press page-down five times or page-up two times, then press either the up or down arrow key to “step” to the line where **LAMP HOURS** is displayed. An on-screen graphic will indicate the accumulated **LAMP HOURS** value. As the P350 is used, the lamp hour value is incremented. The average life expectancy of the metal halide lamp is 2,000 hours. When a new lamp is installed, press either the right or left arrow key to reset the **LAMP HOURS** value to zero.

### **LAMP CYCLES**

To access the menu page with the **LAMP CYCLES** function, press page-down five times or page-up two times, then press either the up or down arrow key to “step” to the line where **LAMP CYCLES** is displayed. An on-screen graphic will indicate the accumulated **LAMP CYCLES** value. Every time the P350 lamp is turned on, the lamp cycle value is incremented. When a new lamp is installed, press either the right or left arrow key to reset the **LAMP CYCLES** value to zero.



### **TV COLOR**

To access the menu page with the **TV COLOR** function, press and release **MENU**, page-up or page-down, then press either the up or down arrow key to “step” to the line where **TV COLOR** is displayed. Press the right arrow key to increase the amount of color in the image. Press the left arrow key to decrease the amount of color in the image. An on-screen graphic will indicate the relative value of the **TV COLOR** setting. This control can only be adjusted when viewing a TV video image.

### **TV SHARPNESS**

To access the menu page with the **TV SHARPNESS** function, press and release **MENU**, page-up or page-down, then press either the up or down arrow key to “step” to the line where **TV SHARPNESS** is displayed. Press the right or left arrow key to select between the eight image sharpness settings. An on-screen graphic will indicate the **TV SHARPNESS** setting. This control can only be adjusted when viewing a TV video image.

## Illuminated Indicators

*POWER*

The *POWER* button glows red when the P350 is plugged into an AC wall outlet and is ready to be turned on; one of the cooling fans should be running at this time.

Keypanel

When the keypanel is lit, indicates that the P350 is in operation; the projector lamp should also be on.

## Remote Control

The RC-10 remote control can be used to remotely change all of the keypanel and on-screen control functions. When a remote control button is pressed, the LED on the remote control blinks rapidly.



**NOTE:** When the remote control operating distance becomes too short for your purposes, install a fresh battery as described in the Remote Control Battery section of this manual.

To use the remote control, point it at the front of the projector and press a key, or “bounce” the IR signal off the viewing screen.

# CARE AND MAINTENANCE

## Storage and Transportation

To prepare your P350 for transport, perform the following steps:

1. Press *POWER* to turn off the projector and lamp. (The main cooling fans will continue turning for approximately three minutes.)
2. When the main cooling fans have stopped turning and the P350 is cool, unplug the power cord.
3. Close the mirror into its storage position.
4. Close the P350 down to its storage position and engage the locking mechanism.



**NOTE:** Store and transport the Firefly™ P350 at temperatures between 0° and 140°F (-17° to 60°C). Avoid storage in automobiles during seasonal temperature extremes. Automobile interior temperatures can exceed 160°F (70°C) in summer and drop below -20°F (-29°C) in winter. If the Firefly™ P350 has been exposed to extremely hot, cold or humid conditions, allow it to stand at room temperature for 30 minutes before use. Take care to protect the Firefly™ P350 from jarring impacts.

## Lens Cleaning

1. Lift the mirror as shown in Figure 6.
2. Gently wipe the exposed lens surfaces with a clean, lint-free tissue (slightly moistened with lens cleaner if necessary). **Never** pour lens cleaner or other solvents on the lens elements.



**CAUTION!** Never use silicone-impregnated eyeglass tissues on the coated projection lens.

## Lamp Replacement

1. Press *POWER* to turn off the projector and lamp. (The main cooling fans will continue turning for approximately three minutes.)



**WARNING!** To prevent burns, allow the lamp access door and projector lamp to cool before attempting to replace the lamp.

2. When the main cooling fans have stopped turning and the P350 is cool, unplug the power cord.
3. Lower the mirror, then close the P350 down to its storage position.
4. Turn the P350 over on a flat, stable surface.

Figure 14. Lamp Replacement

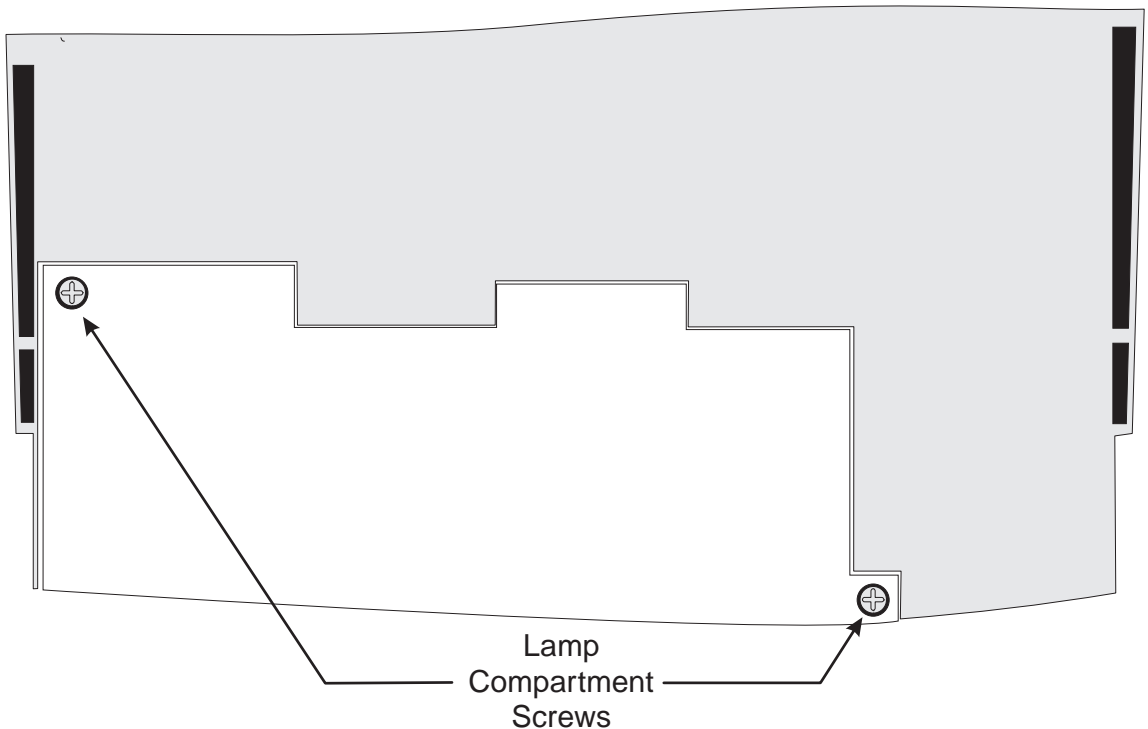



**NOTE:** Typically, metal halide lamps have an average operating life of approximately 2,000 hours. When the On-Screen **LAMP HOURS** shows 2,000 hours of operation, lamp failure may occur soon. You may elect to replace the lamp, or continue using your P350 until the lamp actually fails.

5. Loosen the two lamp compartment screws shown in Figure 14.  
(These are captive screws and should **not** be completely removed.)
6. Lift out the lamp compartment assembly.
7. Install a new lamp compartment assembly.
8. Tighten the two lamp compartment screws shown in Figure 14.

## Fuse Replacement

Figure 15 shows the location of the fuse holder. Use a small flat-blade screwdriver to pop the fuse holder out.



**NOTE:** To access the fuseholder, the Firefly™ P350 must be in its raised position with the power cord unplugged.

Replace the fuses only with the type and rating shown on the label. If the module repeatedly blows fuses, return it for servicing.

**Figure 15. Fuseholder Location**

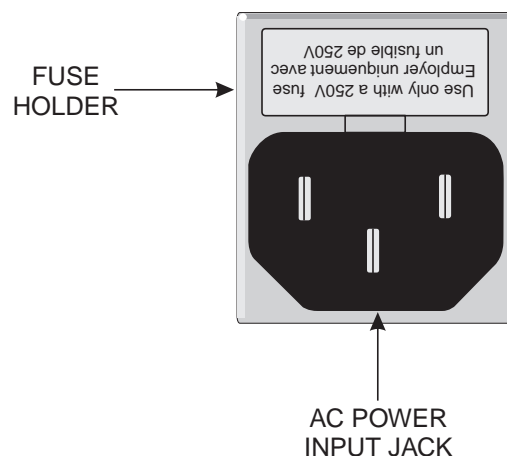

## Troubleshooting Guide

### PROBLEM

### POSSIBLE SOLUTIONS

Telex logo is displayed on Firefly™ P350

- Unit is working properly, but no video source is present.

No image projected from Firefly™ P350

- Firefly™ not turned on.
- Firefly™ not connected to AC wall outlet.
- AC wall outlet defective.
- Computer or video cable not secure.
- No video signal from computer or video source.
- Incompatible video signal from computer.
- Projector lamp burned out.
- Weak video signal or poor VCR tracking.

No image on computer monitor

- Computer or monitor video cable not secure.
- Monitor power off or disconnected.
- Firefly™ not connected to AC wall outlet.
- No video signal from computer.

Poor color or no color

- Adjust brightness, tint, and contrast controls.
- Wrong inverse mode; change **INVERSE** setting.
- Signal from computer is monochrome.
- Computer video cable not secure.
- Select a different color mode using the **PALETTE** function.
- Adjust room lighting.

Flickering or unstable image

- Focus needed; use the **SYNC** control (there are 16 possible settings).
- Computer video cable not secure.
- Incompatible video signal from computer.
- Adjust the **WIDTH** control.

## PROBLEM                      POSSIBLE SOLUTIONS

### Split image or partial image

- Image alignment needed; use up-down and left-right arrow keys.
- Incompatible video signal from computer.
- Reset the Firefly™ to factory default settings.

### Power button not illuminated on keypanel

- Firefly™ not connected to AC wall outlet.
- Defective AC wall outlet.

### No audio from built-in speakers

- No audio source connected.
- Firefly™ not turned on.
- Firefly™ not connected to AC wall outlet.
- AC wall outlet defective.
- Audio source turned off.
- Audio source not connected with appropriate video input.
- Audio source and audio output cables are reversed.
- Volume control is set too low.
- External amplified speaker system connected to the *AUDIO OUT* jack.

### Visible bright spots

- An inactive pixel may appear as a bright spot on the screen, however, it will not affect picture quality or the life expectancy of the P350. (The Firefly™ P350 may contain a maximum of 50 inactive pixels.)

### Image contains one or more vertical bars

- Use the Menu Mode On-Screen Controls to adjust the **WIDTH**. (After eliminating the vertical bars, use **SYNC** to sharpen the image.)



**NOTE:** When adjusting the **WIDTH**, if the left arrow adjustment causes the number of bars to increase, use the right arrow adjustment to eliminate the bars. If the right arrow adjustment causes the number of bars to increase, use the left arrow adjustment to eliminate the bars.

PROBLEM POSSIBLE SOLUTIONS

Image out of focus

- Adjust the focus and keystone controls for best screen image.
- Adjust **SYNC** control.



**NOTE:** If only portions of the image are out of focus and the **SYNC** adjustment causes the out-of-focus portions to move, refer to the solution described in the “vertical bars” problem.



**NOTE:** Displaying a cross-hatch pattern will aid in resolving any focus adjustment problems.

No image on Macintosh monitor

- Incorrect Macintosh computer and monitor adapters.  
(Use the 55093-002 and 550093-003 adapters with the 15-inch Macintosh multisync monitor or with the 12-inch Macintosh monitor. Use the 55093-000 and 550093-001 with non-multisync Macintosh monitors. Use the 55093-003 and 550093-004 with 832 x 624 Macintosh monitors)

No screen image with Macintosh PowerBook

- PowerBook must be turned on after the P350 is connected. (Turn off the PowerBook, then turn it on again.)
- Ensure that Monitor Mirroring is enable on the PowerBook control screen.

Undefined or unresolved problem

- Before calling for technical assistance use the RESET control to restore the factory default settings, then use the Keypanel and Menu Mode On-Screen Controls to make your image enhancements.



## SERVICE INFORMATION

In the interest of promptness (if service is required), it is recommended that you first contact the dealer from whom the equipment was purchased. If modules are to be returned to the dealer or factory, they should be shipped in the original packing material or carefully packed in some other container with sufficient packing material to prevent damage. Technical assistance is available from the Telex Customer Service Department at the following address:

Customer Service Department  
Telex Communications, Inc  
9600 Aldrich Avenue South  
Minneapolis, Minnesota 55420 USA  
Telephone: (612) 884-4051  
(Collect calls not accepted)

Return equipment for factory repair to:

Service Department  
Telex Communications, Inc.  
1720 East 14th Street  
Glencoe, MN 55336 USA



**NOTE:** All equipment returned for repair must be accompanied by documentation stating your return address, telephone number and proof of date of purchase, along with a description of the problem. In lieu of this, you may obtain a Return Authorization Form from our Customer Service Department.

# TECHNICAL SPECIFICATIONS

## P350 Computer Compatibility

- IBM and IBM compatibles with SVGA (800 x 600)
- Macintosh computers with external video (832 x 624 and 800 x 600 modes)
- 640 x 480 mode supported by showing a window with the smaller image

## Computer Interface

HD-15 D-subminiature interface connector

## Color Palette

- 8-color mode: 2 shades per color, 8 total colors
- 16M-color mode: 253 shades per color, 16,194,277 total colors

## LCD Panel

- 6.4" (diagonal measure)
- Active matrix TFT
- Contrast ratio
  - 60:1 minimum
  - 100:1 typical
- 800 x 600 pixel resolution
- Pixel response time for the P350
  - $t_r$  = 10 msec typical
  - $t_f$  = 40 msec typical

## Optical Lens

- 165 mm focal length
- Three element lens

## Computer Video Requirements

- Red, Green, Blue signal input/output (0 to 1.0V at 75 ohms impedance)
- Vertical sync frequency: 50 - 72 Hz
- Horizontal sync frequency: 31 - 48 kHz

### **Composite Video Requirements**

NTSC, PAL or SECAM composite video

### **S-Video Requirements**

NTSC, PAL or SECAM video with separate chrominance and luminance

### **Projection Lamp Requirements**

270 Watt metal halide lamp

### **Input Power**

- 325 Watts
- 120 VAC, 60 Hz; 230 VAC, 50/60 Hz; auto-sensing

### **Weight**

8.9 lbs (4.0 kg)

### **Dimensions**

2.7" (H) x 15.2" (L) x 10.7" (W)  
(68 mm x 386 mm x 272 mm)

### **Environmental Requirements**

- Storage temperature: 0° to 140°F (-17° to 60°C)
- Operating temperature: 32° to 90°F (0° to 32°C)
- Relative humidity: 95% (non-condensing) at 95°F (35°C)

# ABBREVIATIONS

AUX	Auxiliary
B/W	Black and white
CCIR	Comite Consultatif International des Radio Communications
CD	Compact disk
CW	Clockwise
CCW	Counter-clockwise
DOS	Disk operating system
EP	Extended play (same as SLP)
FCC	Federal Communications Commission
LCD	Liquid crystal display
LED	Light emitting diode
LP	Long play
ME-SECAM	Middle East SECAM
NTSC	National Television System Committee
PAL	Phase alternation by line
RAM	Random access memory
ROM	Read only memory
SECAM	Sequentiel Couleur A Memoire
SLP	Super long play (same as EP)
SP	Standard play
SVGA	Super VGA
S-VHS	Super VHS
TFT	Thin film transistor
VAC	Volts-alternating current
VCR	Video cassette recorder
VDC	Volts-direct current
VGA	Video graphics adapter
VHS	Video home system

# INDEX

## A

accessories . . . . . 3  
adapter . . . . . 4, 9, 27  
alignment . . . . . 15, 26  
audio . . . . . 6 - 7, 12, 26

## B

BASS . . . . . 19  
battery . . . . . 11, 21  
BRIGHTNESS . . . . . 15, 19, 25

## C

Caution . . . . . 12, 22  
cleaning . . . . . 22  
color . . . . . 2, 15, 18 - 20, 25, 29  
compatibility . . . . . 29  
compatible . . . . . 2, 29  
connect . . . . . 1, 6 - 7, 10  
connections . . . . . 8 - 9  
connector . . . . . 1, 29  
contract . . . . . 17  
contrast . . . . . 15, 19, 25, 29

## D

default settings . . . . . 14, 16, 26 - 27  
disconnected . . . . . 25  
disconnecting . . . . . 14

## E

ENGLISH . . . . . 17  
enhance . . . . . 14 - 15  
enhancements . . . . . 14, 16, 27  
expand . . . . . 17

## F

fans . . . . . 2, 7, 12, 14, 21 - 23  
features . . . . . 1  
focus . . . . . 2, 12, 25, 27

# INDEX, CONT'D

FRENCH . . . . .	17
fuse holder . . . . .	24
fuse replacement . . . . .	24

## G

GERMAN . . . . .	17
------------------	----

## I

incompatible . . . . .	25 - 26
indicators . . . . .	21
intensity . . . . .	12
INVERSE . . . . .	18, 25

## K

keypanel . . . . .	2, 15, 26
keystone . . . . .	12

## L

lamp . . . . .	12, 16, 30
lamp access . . . . .	12, 23 - 24
LAMP CYCLES . . . . .	20
LAMP HOURS . . . . .	20, 24
lamp replacement . . . . .	23
language . . . . .	17
LCD . . . . .	2, 29, 31
LED . . . . .	11, 21, 31
lift . . . . .	7
locking . . . . .	7, 22

## M

MENU . . . . .	16 - 17, 20
mirror . . . . .	12, 18

## P

PAGE . . . . .	16
PALETTE . . . . .	18, 25, 29
pixel . . . . .	2, 26, 29
POWER . . . . .	7, 12, 14, 16, 21

# INDEX, CONT'D

## R

raised position . . . . .	7, 24
release . . . . .	7
remote control . . . . .	3 - 4, 11, 21
RESET . . . . .	16, 20, 27

## S

service . . . . .	28
settings . . . . .	12, 16 - 17, 20, 25
setup . . . . .	6, 12
SOURCE . . . . .	14, 16
SPANISH . . . . .	17
storage . . . . .	22, 30
SYNC . . . . .	12, 17, 25 - 27

## T

TINT . . . . .	19
TREBLE . . . . .	19
TV COLOR . . . . .	20
TV SHARPNESS . . . . .	20

## V

vents . . . . .	6
video . . . . .	1 - 2, 6, 8, 10, 14, 16, 20, 25 - 26, 29
VOLUME . . . . .	14 - 15, 18

## W

Warning . . . . .	6, 12, 23
WIDTH . . . . .	17, 25 - 26



TELEX COMMUNICATIONS, INC. • 9600 Aldrich Ave. So., • Minneapolis, MN 55420 U.S.A.



## Free Manuals Download Website

<http://myh66.com>

<http://usermanuals.us>

<http://www.somanuals.com>

<http://www.4manuals.cc>

<http://www.manual-lib.com>

<http://www.404manual.com>

<http://www.luxmanual.com>

<http://aubethermostatmanual.com>

Golf course search by state

<http://golfingnear.com>

Email search by domain

<http://emailbydomain.com>

Auto manuals search

<http://auto.somanuals.com>

TV manuals search

<http://tv.somanuals.com>