

MODEL 804-100A AMPLIFIER OPERATING INSTRUCTIONS

DESCRIPTION

The Raymer Model 804-100A is a multi-purpose 100 watt RMS monaural all silicon solid state amplifier. It is designed for dependable, continuous operation in background music, paging, or sound reinforcing systems. In addition to a Hi Z or Lo Z microphone input, two music inputs are available for use with a tuner, a high output ceramic or crystal phono, a tape recorder with its own preamp, or other auxiliary equipment. Model 804-100A is supplied with separate bass and treble controls, which may be used to compensate for room and speaker characteristics. A special switch is provided to protect a trumpet speaker diaphragm from low frequency power. The amplifier has speaker outputs of 16 ohms, 25 volt and 70 volt balanced or unbalanced lines.

The amplifier also features an electronic switching (PRECEDENCE) circuit in place of a relay to quickly fade out the music while paging; after the page, the music is smoothly restored. The precedence feature operates only on the music input.

Model 804-100A is equipped with an interlock feature which permits connecting together two or more 804-100A Amplifiers so that they may be operated simultaneously to deliver a total power in multiples of 100 watts into a speaker line.

UNPACKING:

The unit is to be removed carefully from the carton and inspected for any possible damage in transit. If there is any evidence of any damage which might have occurred in shipment, notify your dealer at once, or the transportation company which delivered it. Claims for damage sustained in transit must be made upon the Carrier. Save all packing material for inspection by the claim agent who will furnish you with the proper forms and will also give you the necessary instructions for filing a claim. In addition to the Unit, there should be a warranty card included in the carton.

To insure proper servicing and to protect your rights under the warranty, be sure to fill in the warranty registration card without delay and mail to the factory.

INSTALLATION:

Model #804-100 amplifier has ample vents for normal ventilation; however, it should be placed so as to permit free air flow around the unit. DO NOT PLACE ANY OBJECT ON TOP OF THE PERFORATED COVER. DO NOT STORE OR OPERATE THE AMPLIFIER in areas where the ambient temperature exceeds 140 degrees F.

Plug the AC line cord in any outlet furnishing 105 to 120 volts, 60 cycles AC.

An AC receptacle is located on the back of the chassis to supply power to other components such as phonograph motor, etc. The auxiliary equipment connected to the AC receptacle is controlled by the POWER on-off switch so that turning off the unit turns off all equipment.

CONNECTIONS:

All connections are made on the rear panel of the unit, and are clearly identified.

CONTROLS AND INPUT CONNECTIONS

The music channel has two inputs depending on the source of the signal. For a high impedance input such as a tuner or a phono with its own preamp, or other auxiliary equipment of a similar nature, the input marked MUSIC Hi-Z should be used. If the source is a balanced line such as a telephone line, the 500 OHM input may be used with the plug-in transformer (either UTC #P-1, Microtran #M1-P, or equivalent) installed in the octal socket on the chassis. The 500 ohm input phono jack is not grounded so that the input from a balanced line may be connected to the two leads of a phono plug. As an alternate to the use of a plug-in transformer, Raymer Telephone Matching Adaptor TM-1 may be connected to the MUSIC Hi-Z input.

The MICROPHONE input is for an unbalanced line only. If it is desirable to use a balanced input, an outboard matching transformer must be used. The switch above the microphone input selects the proper input impedance. The Hi-Z position will match either crystal or high impedance dynamic microphones; the Lo-Z position will match microphones in the 150 to 500 ohm range.

To avoid possible supersonic oscillation which might result in damage to the unit, it is mandatory that a shielded (metal cover) microphone plug be used.

In the event a telephone switchboard, a dial access telephone, or internal telephone system is used as a paging source in place of a microphone, the Raymer TM-1 Adaptor may be used to match the telephone line to the microphone input.

The Bridging jack may be used for either input or output applications. It is connected electrically between the pre-amplifier and power amplifier sections of Model 804-100, and may therefore be used (1) as the output of the pre-amplifiers into an external amplifier and/or tape recorder, or (2) from the output of an external source into the power amplifier section. When the Bridging jack is used to feed an external amplifier or tape recorder, the Bridging circuit is not affected by the Master Volume, Bass, and Treble controls. When the Bridging jack is used as the input from an external source (such as a microphone mixer-preamplifier when additional microphones are required) the reproduction from the external source will be affected by the Master Volume, Bass, and Treble controls.

In order to protect horn loaded drivers the switch marked TRUMPET PROTECT/NORMAL should be placed in the "Trumpet Protect" position. This reduces the bass frequencies and protects the driver diaphragms. For use with cone type loudspeakers the switch should remain in the "Normal" position.

The separate Bass and Treble controls provide a flat response when set in a center position. These controls can either boost or reduce the bass and treble to compensate for room and speaker characteristics.

If it is desirable to fade out the music while paging, a "dispatcher" type of microphone, such as Raymer Model 201, or an equivalent microphone with an auxiliary switch should be used. The microphone is to be connected as shown in Figure 1.

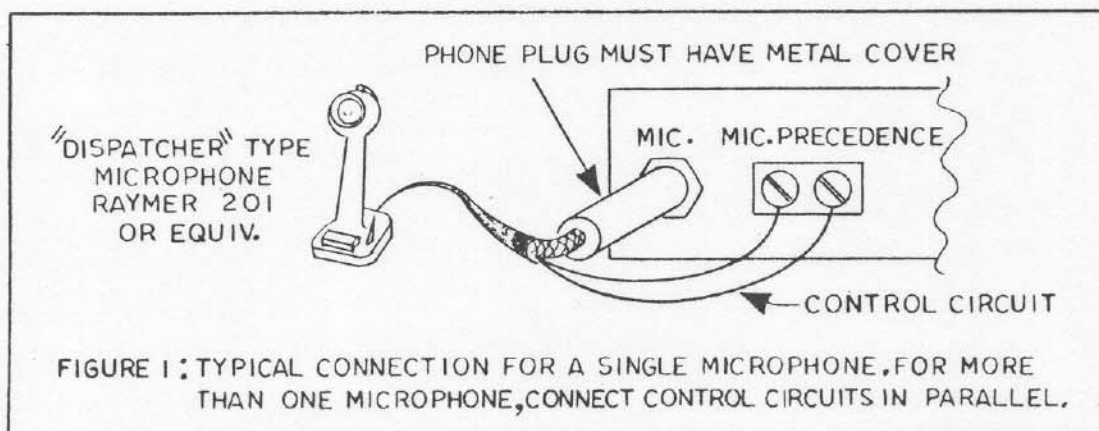

OUTPUT CONNECTIONS

All connections are made on the rear of the unit.

The INTERLOCK jack is connected electrically between the preamplifier and power amplifier section of Model 804-100A. It may either be used as the output of the preamplifier into an external amplifier or tape recorder, or to connect additional Raymer 804-100A Amplifiers for increased power to a speaker line.

By inter-connecting the INTERLOCK jack of two or more Raymer 100 watt amplifiers with a patchcord, they may be operated simultaneously to deliver a total output power in multiples of 100 watts into one speaker line.

As an example: The 70 volt outputs of the two 100 watt Raymer amplifiers may be connected in parallel to deliver 200 watts to a 70 volt line, or in series to deliver 200 watts to a 140 volt line. If a system requires 300 watts of power, the 25 volt outputs of three 804-100A's may be connected in series to drive a 70 volt line with no appreciable mismatch.

The output terminals of the 804-100A have been phased at the factory so that each terminal is in phase with the corresponding terminal of any other Raymer 804-100A Amplifier. For parallel or series connection, the terminals should be wired as shown below.

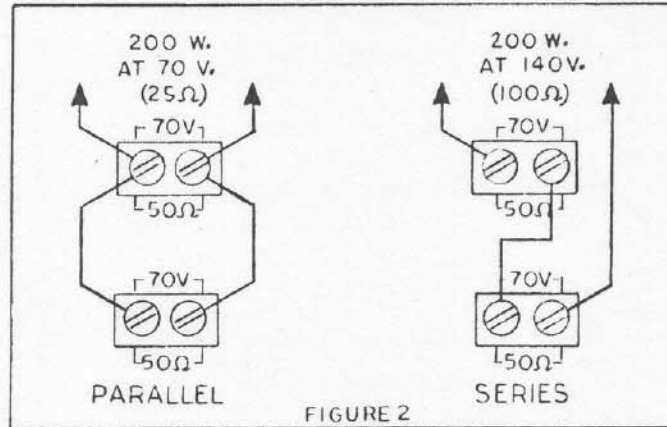

CAUTION: BEFORE OPERATING AMPLIFIERS CONNECTED IN EITHER SERIES OR PARALLEL, MAKE SURE THE INTERLOCK JACKS HAVE BEEN CONNECTED TOGETHER BY MEANS OF A JUMPER CABLE WITH A PHONO PLUG AT EACH END.

WHEN CONNECTING THE OUTPUTS IN SERIES, MAKE SURE THE JUMPER BETWEEN COMMON (COM) AND GROUND (GND) IS REMOVED.

WHEN CONNECTING THE OUTPUT IN SERIES, MAKE SURE THE CENTER TAP TERMINAL IS DISCONNECTED FROM THE GROUND TERMINAL ON EACH UNIT. THIS TERMINAL IS LOCATED ON THE LEFT SIDE OF THE OUTPUT TERMINAL STRIP.

The speaker(s) or line matching transformers are connected to the screw terminal board located on the rear panel. For short distances, any ordinary insulated wire, such as parallel lamp cord, may be used.

Connecting to the 25 volt or 70 volt tap on the unit permits the use of a number of speakers each with its own corresponding line matching transformer, thereby eliminating the necessity of calculating impedances. The tap on the line matching transformer is selected to give the power desired for each speaker. The total of all the power settings should be no greater than the amplifier output rating.

Three output impedances are available. 16 ohms (40V), 25V (.6.2 ohms), and 70V (50 ohms). These outputs are balanced to ground by means of a jumper on the back panel connecting the center tap of the output transformer and ground. If it is desirable to operate the lines in an unbalanced mode, remove the jumper and connect a wire between the terminal marked GROUND and one side of the output line that will be used.

Long lines have an appreciable resistance with a resultant power loss. The use of parallel matching transformers on either 25 volt or 70 volt lines is recommended for long distances. When it is desired to have less than 15% power loss, the following table may be used as a guide for the proper wire size to be used. In all cases, it is advisable to run as heavy a wire as possible consistent with the requirements.

WIRE SIZE B & S	MAXIMUM LENGTH OF LINE BETWEEN OUTPUT AND LOAD		
	16 Ohms (40V)	6.2 Ohms (25V)	50 Ohms (70V)
14	460'	180'	775'
16	300'	115'	520'
18	180'	70'	350'
20	115'	45'	205'

Optimum performance of any transistor amplifier depends on the proper current delivered at the output terminals. Connecting a total load impedance at any tap less than the impedance indicated on the back panel of the amplifier will cause the transistors to deliver more current than they were designed for and will deteriorate the performance of the unit and cause damage to the transistors. To prevent this from occurring and to protect the components, the unit is equipped with a circuit breaker that will trip if the output impedance is below the specified rated value; for example, if two 8 ohm speakers are connected in parallel (resulting in a 4 ohm impedance), and in turn connected to the 8 ohm output terminal, the circuit breaker will trip as soon as the volume control is turned up to the unit's maximum output.

When output leads are run near an unshielded microphone input plug, or when run together with the microphone precedence leads, a supersonic oscillation may occur. When this does occur, it will appear as a distortion in the amplifier output, and oftentimes will cause the circuit breaker to "trip".

To prevent this oscillation from occurring, it is recommended that shielded microphone plugs be used wherever possible. In the event that an unshielded plug or a molded cable assembly is used, keep the output leads away from the Microphone input(s) and Microphone precedence leads.

In installations where there is no alternative but to run both output and microphone precedence lines together, a .1 Mfd capacitor is to be connected from one side of the Microphone Precedence terminal to ground. This will shunt out the feedback signal and more than likely prevent the supersonic oscillation.

The power transistors are mounted on the back panel. In the event it becomes necessary to replace these transistors, be certain that:

1. No grit or metal particles are lodged between the transistor and the mica or back panel.
2. The mica insulator is not damaged.
3. Both sides of the mica insulator are covered with Dow Corning 7 Silicone Grease or equivalent.
4. The mounting screws are tight, and also that the protective cover does not touch the transistor.

CAUTION:

THIS UNIT IS EQUIPPED WITH A CIRCUIT BREAKER DESIGNED TO PROTECT THE TRANSISTORS AGAINST OVERLOAD. IN THE EVENT THAT THE CIRCUIT BREAKER CONSTANTLY "KICKS OUT", CHECK THE LOAD ON THE OUTPUT OF THE AMPLIFIER FOR EITHER A SHORT CIRCUIT OR AN IMPEDANCE LOWER THAN THE VALUE RECOMMENDED. IF THERE IS NO SHORT CIRCUIT AND THE LOAD IS CORRECT, CHECK TO SEE IF POSSIBLY THE INPUT AND OUTPUT OR MICROPHONE PRECEDENCE LEADS ARE RUNNING CLOSE TOGETHER. IF THEY ARE, THEY SHOULD BE SEPARATED AND TREATED AS INDICATED ABOVE. IN THE EVENT THAT THE LOAD IS CORRECT AND THE LEADS ARE NOT RUNNING TOGETHER, DO NOT ATTEMPT TO DEFEAT THE FUNCTION OF THE CIRCUIT BREAKER BUT HAVE THE UNIT CHECKED FOR OTHER DEFECTS.

WARRANTY

This unit has been very carefully inspected and should require no further service. Each unit is warranted to be free from defects in material and workmanship under normal use and service for a period of one year from date of delivery to the original purchaser. If this unit appears to be defective, the factory will repair any unit returned within said one year, providing all transportation charges are pre-paid, and which our examination shall disclose to our satisfaction to be defective.

This Warranty does not include free labor, nor is it applicable to any unit which shall have been subject to accident, tampered with, mis-used, abused, or altered in any manner whatsoever. Further, this Warranty shall not apply to any unit which has been connected improperly.

It is recommended that any unit on which service is required, be processed through your dealer wherever possible.

This Warranty is expressly in lieu of all other Warranties, expressed or implied, and of all other obligations or liabilities on our part. We neither assume nor authorize any other person to assume for us any other liability in connection with the products manufactured by Trutone Electronics, Inc.

TRUTONE ELECTRONICS, INC.

7315 FULTON AVE., NORTH HOLLYWOOD, CALIFORNIA

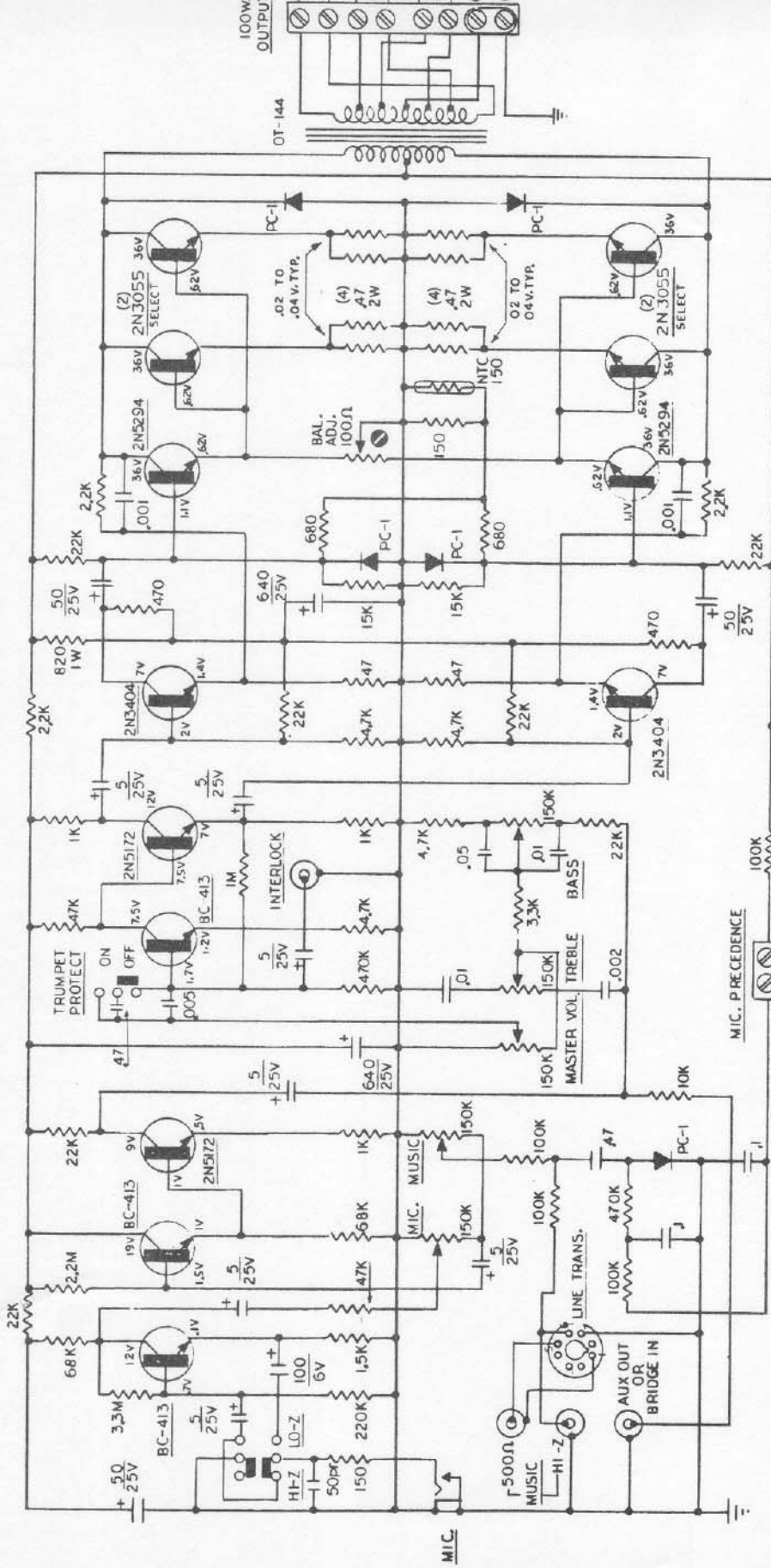

- NOTES; EXCEPT WHERE SPECIFIED
1. CAPACITOR VALUES ARE IN MF.
 2. RESISTOR VALUES ARE IN OHMS.
 3. RESISTORS ARE 1/2 W. 10 %.
 4. BAL. ADJ. ONLY WHEN DRIVER OR OUTPUT TRANSISTOR IS CHANGED. (ADJUST FOR MINIMUM HUM AT OUTPUT WITH ALL FRONT CONTROLS CCW)

TRUTONE ELECTRONICS INC.
 HO. HOLLYWOOD, CAL.

RAYMER MODEL 804-100A

100 WATT AMPLIFIER

ENGINEER; KOGGE

DATE; 4/1/69 REV. 10

Free Manuals Download Website

<http://myh66.com>

<http://usermanuals.us>

<http://www.somanuals.com>

<http://www.4manuals.cc>

<http://www.manual-lib.com>

<http://www.404manual.com>

<http://www.luxmanual.com>

<http://aubethermostatmanual.com>

Golf course search by state

<http://golfingnear.com>

Email search by domain

<http://emailbydomain.com>

Auto manuals search

<http://auto.somanuals.com>

TV manuals search

<http://tv.somanuals.com>