

Telex

Operating Instructions

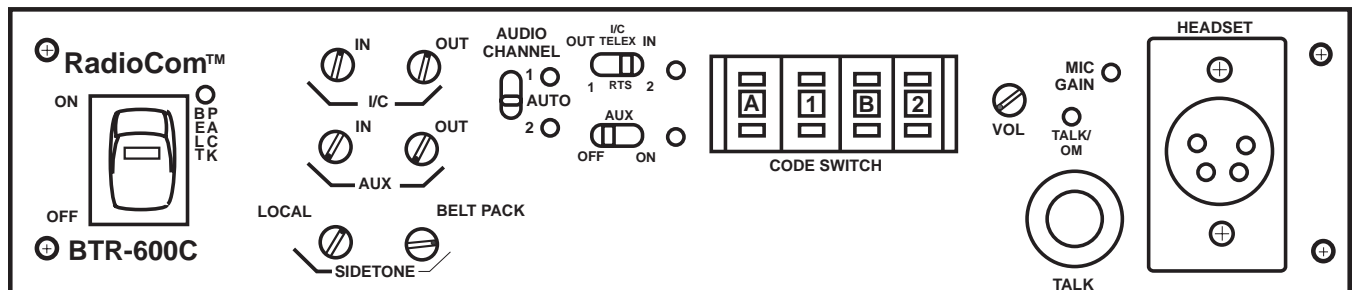

RadioCom™

BTR-500/600C

TR-500/600C

Professional

Wireless

Intercom Set

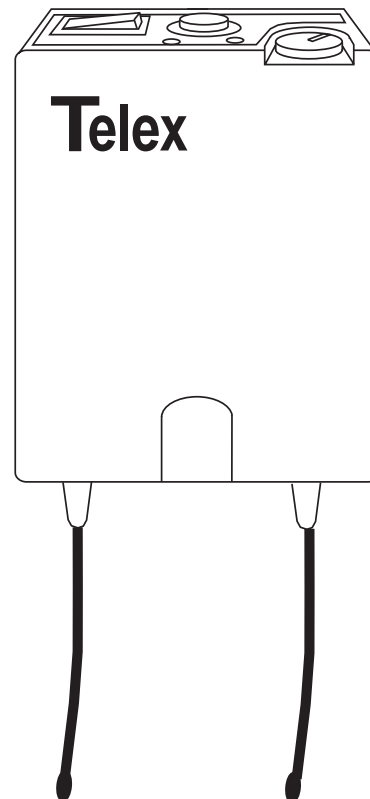

TELEX®

Table of Contents

Introduction	1
General Description	1
System Features	1
Base Station Transceiver	2
Controls And Connections	2
Front Panel	2
Rear Panel	3
Specifications	4
Beltpack Transceiver	5
Controls and Connections	5
Specifications	6
Initial Equipment Set-Up	7
Unpacking	7
Antenna Information	7
Antenna Connections	7
Antenna Polarization	8
Distance Between Antennas	8
Antenna Placement	8
Improving Reception/Increasing Range	10
Base Station Set-up	11
Location	11
Rack Mounting	11
Local Headset Connection	11
RF Transmit/Receive Channel Switches	11
RF Transmit Mode Switch	12
Intercom Type Switch	12
Dual Listen Switches	12
Audio Channel Switch	13
Telex In/Out Switch	13
Auxiliary Switch	13
Auxiliary to I/C Switch (program audio)	13
Code Switch (BTR-600C Only)	13
Interconnection to a Hard-wired Intercom	14
Auxiliary Audio Connection	17
Power Connection	17
Dummy Load	17
Beltpack Set-up	18
Headset Connection	18
RF Transmit/Receive Channel Switches	18
RF Transmit Mode Switch	18
Code Switch (TR-600C Only)	18
Battery Installation	19
Pre-Walk-Thru Checklist	20

Table of Contents (Continued)

System Operation	21
Base Station Operation	21
Power	21
Push-to-Talk/Lock-to-Talk Switch.....	21
Local Headset Volume	21
Microphone Gain	21
Dual Listen Level.....	22
Intercom Level	22
Auxiliary Level	22
Sidetone Level	22
Beltpack Operation	23
Power/Local Headset Volume.....	23
Battery Check.....	23
Push-to-Talk/Lock-to-Talk Switch.....	23
Microphone Gain	23
Sidetone Level	24
Example System Configurations.....	25
Single Base Station AudioCom (Telex) System	25
Single Base Station RTS System	26
Six Base Station RTS System	27
Eight Base Station Telex System	28
Single Beltpack to Single Beltpack System.....	29
System Walk-Thru	30
Troubleshooting	31
Tech Tips	32
Codes Settings and the BTR-600C	32
Frequency Interaction	32
Microphone Gain Adjustment.....	33
Battery Information	33
Intercom System Specifications	33
Accessories	34
Customer Service Information	35
FCC Information	36

Introduction

General Description

The Telex Radiocom BTR-500 and BTR-600C UHF Wireless intercom systems offer the ultimate in reliable, high performance, high fidelity full duplex communications.

The BTR-500 series includes the BTR-500 frequency agile base station, working with the TR-500 transceiver beltpack. The BTR-500 base station provides full duplex communications with a single beltpack. Sixteen BTR-500s, or more, may be operated simultaneously. Also a single BTR-500 base station can accommodate an unlimited number of beltpacks operating in "Push-to-Transmit" mode.

The BTR-600C series has all the features of the BTR-500 with the addition of digital modulation and encryption for secure communications. Base station and beltpacks can choose from over 65,000 user selectable security codes out of over 16 million possible codes by means of four cipher code switches on the units. Sixteen BTR-600C, or more, may be operated simultaneously, permitting 16, or more, discrete full duplex radio channels.

The BTR systems incorporate auto-switching 2 channel operation, permitting the beltpack operator to choose between 2 separate audio channels of communications, with the base station tracking the beltpack selection. Auto-switching allows the user the flexibility to create a party-line and a private line within the same beltpack.

The BTR-500 and BTR-600C systems are perfectly suited for stand-alone operation and also can interface with Audiocom® (Telex), RTS® TW, as well as RTS Matrix systems and other 4 wire communications systems. Clear-Com® intercom system may also be interfaced to a BTR-500 and BTR-600C systems through the use of a Telex to Clear-Com Interface box, see "Accessories" for more information. In addition to the external intercom systems interfaces listed above, the base stations provide connections for auxiliary balanced audio input and output.

The Radiocom BTR series has been designed for reliable, efficient operation. Operating in the 520 to 760 MHz range, the units operate reliable at distances of 1,000 feet. With available antenna systems from Telex, the effective operating range can be extended. The high efficiency beltpacks provide 12 hours of uninterrupted operation using standard alkaline batteries.

System Features

- Compatible with Audiocom (Telex), RTS TW, RTS Matrix, Clear-Com (with external interface box), and other wired intercom types.
- Intercom loop thru jacks for connecting multiple units.
- Full Duplex (simultaneous talk and listen) operation.
- Beltpack TR unit contained in a weather and shock resistant die cast magnesium case.
- Digitally encrypted RF (Radio Frequency) link for secure communication on the 600C version.
- Flexible power requirements. The base unit can be powered by any 12 to 15 Volt, AC or DC, 400 mA power source. An external AC wall supply is supplied with the unit.
- Two transmit and two receive RF channels to help avoid radio interference.
- Base stations are table or rack mountable.
- Audio channel switch on the beltpack unit enables it to remotely control the intercom channel on the base unit.
- Two channels of audio.
- Beltpack batteries last up to 12 hours when using standard AA alkaline batteries.
- Audio out jack for P.A. systems or other external audio systems.

Base Station Transceiver Controls and Connections

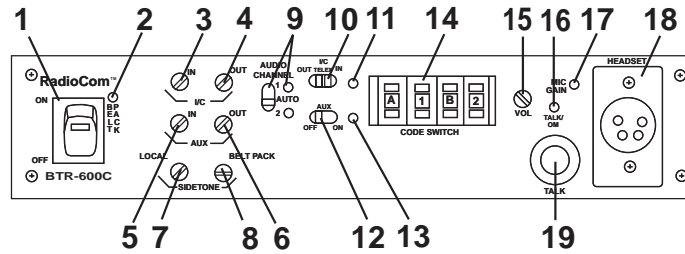
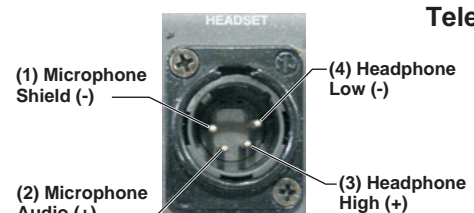

Figure 1
Front Panel Controls and Connections

1. **Power Switch** - Illuminates when on.
2. **Beltpack Light** - Illuminates when a beltpack is transmitting to base station.
3. **Intercom In Level Control** - Adjust for optimum level. Intercom light #11 should just flash red on loudest speech.
4. **Intercom Out Level Control** - Adjusts output to match input level of wired intercoms.
5. **Auxiliary In Level Control** - Adjust for optimum level. Auxiliary light #13 should just flicker from green to red on loudest sounds.
6. **Auxiliary Out Level Control** - Adjusts output to match input level of auxiliary equipment.
7. **Sidetone Local Control** - Adjusts level of voice feedback to earphone when a headset is plugged into jack #18.
8. **Sidetone Remote Control** - Controls sidetone level in the beltpack.
9. **Audio Channel Switch And Lights** -
 - A. **"I/C" switch on rear panel set to Telex** - Selects either "I/C 1 or 2" jack (and corresponding pins on "I/C Loop Thru"). In "Auto" position; allows selection of channels 1 or 2 from the beltpack.
 - B. **"I/C" switch on rear panel set to RTS** - Selects RTS channel 1 or 2 on both I/C jacks (and corresponding pins on "IC Loop Thru"). In "Auto" position; allows selection of channels 1 or 2 from the beltpack.
10. **Intercom Switch** - See settings below.
 - A. **"I/C" switch on rear panel set to "Telex"**
 1. "Telex Out" Setting - Intercom is disconnected from all "I/C" jacks on rear panel.
 2. "Telex In" Setting - Intercom is connected to "I/C Loop Thru" and "I/C 1 or 2" jacks. Channel 1 or 2 is selected by switch #9 or the channel switch on the beltpack.
 - B. **"I/C" switch on rear panel set to "RTS"** - Switch has no effect. All I/C jacks on rear panel are active on either setting.
11. **Intercom Light** - Flashes red when input level is too high. See #3 for adjustment.
12. **Auxiliary Switch** - Turns the auxiliary input on and off.
13. **Auxiliary Light** - Illuminates green when switch #12 is on. Flashes red when input level is too high. See #5 for adjustment.
14. **Code Switch (BTR-600C Only)** - Allows user to select cipher code (over 65,000 available). Any combination of letters and/or numbers may be selected except 0000. Data is unencrypted when the setting is 0000. The code switch settings on the BTR-600C and TR-600C must match exactly.
15. **Volume, Headset** - Controls volume on headset plugged into #18
16. **Talk/Overmodulation Light** - Illuminates green when talk switch #19 is on. Flashes red when headset microphone is over modulated - See #17 for adjustment.
17. **Microphone Gain Control** - Adjust so that light #16 just flickers from green to red on the loudest speech.
18. **Headset Connector** - Standard "XLR" type. Plug for Telex units and jack for RTS units. Wired as follows:

Telex Units



RTS Units

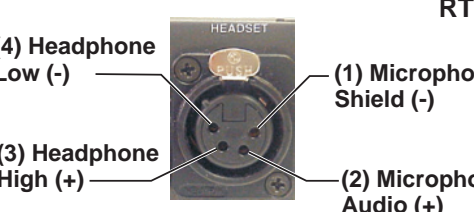

Figure 2 Headset Wiring

19. **Talk Switch** - Press-to-talk, release to disable. Press and release quickly to stay on.

Base Station

Controls and Connections - Rear Panel

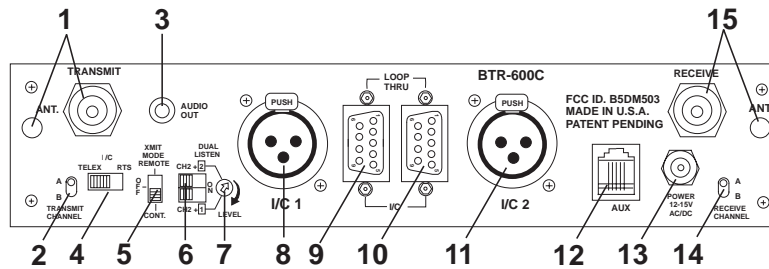



Figure 3

Controls and Connections - Rear Panel - BTR-600C

- Transmit Antenna Jack** - Color band on antenna must match color dot on base station. Female "TNC" Connector.
- Transmit Channel Switch** - Changes frequency of beltpack (shown on Serial No. Tag). Must match receive channel on beltpack.
- Audio Out** - "RCA" type jack provides a high impedance output for an audio amplifier.
 
- I/C Switch** - Set for Telex or RTS type intercom systems. See Figures 4 and 5.
- Transmit Mode Switch** -
 - "Remote"** - The unit transmits only when the beltpack is transmitting.
 - "Off"** - The unit does not transmit.
 - "Continuous"** - The transmitter is on continuously. (Recommended Setting)

A.	CH1+2=OFF CH2+1=OFF	Both audio channels are isolated from each other.
B.	CH1+2=ON CH2+1=OFF	Audio channel 2 is mixed into channel 1.
C.	CH1+2=OFF CH2+1=ON	Audio channel 1 is mixed into channel 2.
D.	CH1+2=ON CH2+1=ON	Both audio channels are mixed into each other.

- Dual Listen Switches**
- Dual Listen Level Control**-Adjusts level of audio mix.

8. & 11. Intercom 1 and 2 Jacks -

- I/C Switch (#4) set to Telex** - "I/C 1" or "I/C 2" (and matching pins on jacks 9 and 10) are selected by the Audio Channel switch on the front panel or the Channel switch on the base station.

If one or both intercom lines are not used, plug the Telex dummy load(s) into the appropriate unused jack(s).

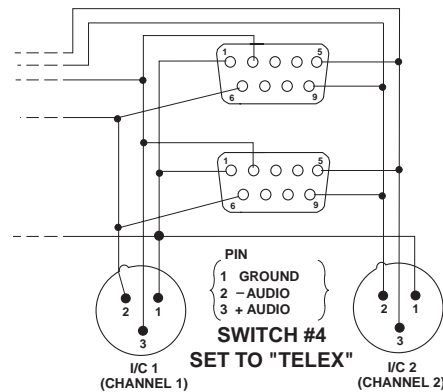

Figure 4

Intercom 1 and 2 Jacks - Switch set to Telex

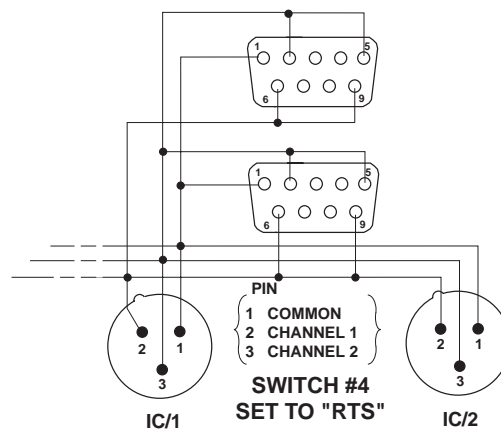

Figure 5

Intercom 1 and 2 Jacks - Switch set to RTS

- I/C Switch (#4) set to RTS** - "I/C 1" and "I/C 2" are connected in parallel (including matching pins on jacks 9 and 10). Channels 1 and 2 are selected by the Audio Channel switch on the front panel or the channel switch on the base station.

If neither channel 1 or 2 are connected to other intercoms, plug the RTS dummy load into the "I/C 1 or 2" jack. Do not use the dummy load if the unit is connected to an RTS intercom system.

9. & 10. **Loop Thru I/C** - 9 pin D-sub jack. Wired as shown.

11. See #8.

12. **Auxiliary Jack** - 6 pin RJ-11 telephone type jack. Compatible with "RTS Matrix" type intercoms.

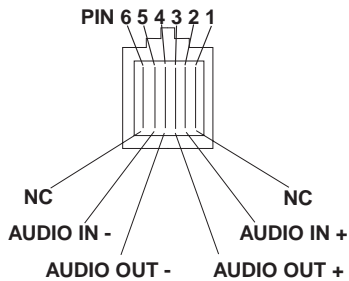

Figure 6
Auxiliary Jack

13. **Power Jack** - 12-15 VDC, 400mA minimum or 12-15 VAC rms, 400mA rms minimum. Accepts 5.5 mm x 2.1 mm plug.

14. **Receive Channel Switch** - Changes frequency of receiver (shown on Serial No. Tag). Must match transmit channel on beltpack.

15. **Receive Antenna Jack** - Color band on antenna must match color dot on base station. Female "TNC" Connector.

BTR-500/600C Specifications

RF Output	40 mW maximum, 25mW typical
Temperature Range.....	-4°F to 130°F (-20°C to 55°C)
Dimensions	8.25"W x 1.75"H x 11.25"D (21cm x 4.5cm x25.6cm)
Weight	4 lbs. (1.8kg)
Modulation Type	
BTR-600C.....	NFSK
BTR-500	FM
Deviation	
BTR-600C	Complies with FCC 74.861e6
BTR-500	±40 KHz
Frequency Response	
BTR-600C	300-4500 Hz
BTR-500	300-8000 Hz
RF Frequency Stability	0.005% crystal controlled
Modulation Limiter.....	Internal Compressor
Microphone input sensitivity	2.0-25 mV
Radiated Harmonic and Spurious.....	Meets or exceeds FCC specifications Typically -45 dBc or better
RF Frequency Range	520 to 608 and 614 to 760 MHz
Receiver sensitivity	Less than 0.5 uV for 12 dB SINAD.
I.F. Bandwidth	
BTR-600C	230 KHz at -3dB
BTR-500.....	150 KHz at -3dB
Type	Single Conversion Superhet, 10.7 MHz I.F.
Image Rejection.....	70 dB or better
Audio Output, Headset	32 mW into 600 Ohms
Squelch	
BTR-600C	Internal, 3.0 μV
BTR-500	Internal, 1.5 μV
FCC	Transmit, Part 74 Receive, Verification, Part 15
FCC ID	B5DM503 (BTR-600C), B5DM505 (BTR-500)

Beltpack Controls and Connections

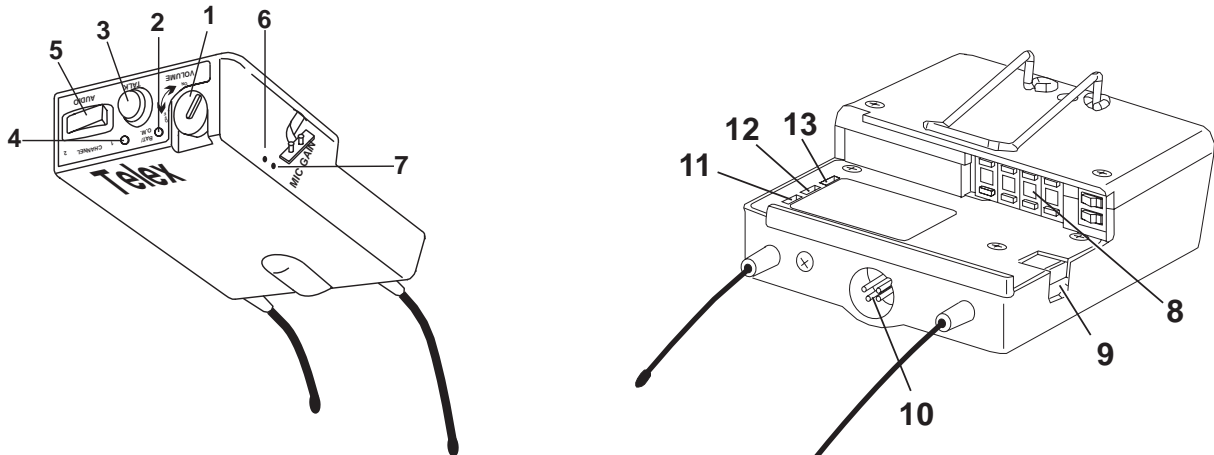

**Figure 7
Controls and Connections**

1. **Volume Control and Power Switch** - Turns power on and off and controls headset volume.
2. **Battery/Overmodulation Light** - Flashes once when unit is turned on if battery is good. If light stays on, battery is low. If light does not flash, battery is dead.

Flickering red light when talking means microphone gain is too high and speech will sound distorted. Adjust Mic Gain control #7 so that the light barely flashes on the loudest speech.

3. **Talk Switch** - Press to talk, release to disable. Press and release quickly to stay on continuously.
4. **Talk Light** - Illuminates when Talk function is on.
5. **Audio Channel Switch** - The Audio Channel Switch enables the beltpack user to switch between wired intercom channels 1 and 2 on the base station.
6. **Side Tone Control** - (Only installed in special beltpack to beltpack direct communications units). Adjusts level of voice feedback to earphone for a headset that is plugged into the jack #10. The "Remote Sidetone" on the base station controls the beltpack sidetone in standard units.
7. **Microphone Gain Control** - Adjust so the light #2 barely flashes on the loudest speech.
8. **Code Switch (TR-600C Only)** - Allows the user to select a cipher code (over 65,000 available). Any combination of letters and/or numbers may be selected except 0000. Data is unencrypted when the setting is 0000. The code switch settings on the TR-600C and BTR-600C must match exactly.
9. **Battery Latch** - Press down to release the battery pack. Pack slides off in opposite direction.

10. **Headset Connector** - Standard "XLR" type. Plug for Telex units and jack for RTS units. Wired as shown.

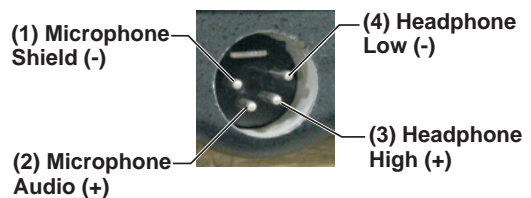

Telex Units

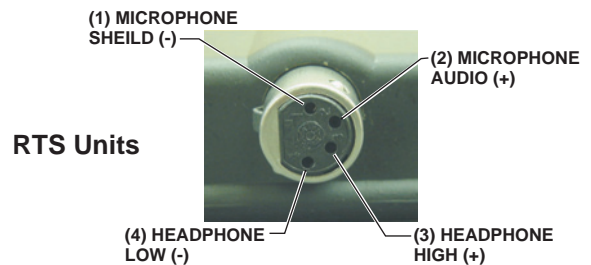

RTS Units

**Figure 8
Headset Jack Wiring**

11. **Push-to-Talk/Push-to-Transmit** - When the switch is set to "Push-to-Talk", the transmitter in the beltpack is always on, but no audio signal is sent unless the Talk Switch #3 is activated. The "Push-to-Talk" switch setting is the recommended position.

When the switch is set to "Push-to-Transmit", the transmitter is turned on when the Talk Switch is activated and turned off when the talk switch is deactivated.

12. **Receive Channel** - Changes the frequency of the receiver. It must match the Transmit Channel of the base station.
13. **Transmit Channel** - Changes frequency of the transmitter. It must match Receive Channel of the base station.

Beltpack Specifications

RF Output	25mW typical
Temperature Range.....	-4°F to 130°F (-20°C to 55°C)
Dimensions.....	4"W x 5 7/8"H x 1 5/8"D (120mm x 149mm x 41mm)
Weight.....	1 lb. 6 oz. (625g) with batteries
Modulation Type	
TR-600C	NFSK
TR-500.....	FM
Deviation	
TR-600C	Complies with FCC 74.861e6
TR-500	±40 KHz
Frequency Response	
TR-600C.....	300-4500 Hz
TR-500	300-8000 Hz
RF Frequency Stability	0.005% crystal controlled
Modulation Limiter.....	Internal Compressor
Microphone input sensitivity	2.0-25 mV
Radiated Harmonic and Spurious.....	Meets or exceeds FCC specifications Typically -45 dBC or better
RF Frequency Range	520 to 608 MHz and 614 to 760 MHz
Receiver sensitivity	Less than 0.5 uV for 12 dB SINAD.
I.F. Bandwidth	
TR-600C.....	230 KHz at -3dB
TR-500	150 KHz at -3dB
Type	Single Conversion Superhet, 10.7 MHz I.F.
Image Rejection.....	70 dB or better
Audio Output, Headset	32 mW into 600 Ohms
Squelch	
TR-600	Internal, 3.0 μV
TR-500.....	Internal, 1.5 μV
FCC	Transmit, Part 74 Receive, Verification, Part 15
FCC ID	B5DM506 (TR-500), B5DM504 (TR-600C)

Initial Equipment Set-Up

Unpacking

Unpack your RadioCom System. A system package should contain the following Items:

Contact the shipper or your dealer immediately if anything is damaged or missing. Fill out the registration card and return it to Telex to properly register your unit.

Quantity	Description
1	BTR-500 or BTR-600C Base Station
1	TR-500 or TR-600C Beltpack
1	Wall Power Supply
2	Antennas (one Transmit and one Receive)
1	Interconnect Cable (9 pin to 9 pin)
2	Dummy Loads (3 pin XLR male)
1	Operating Instructions
1	Warranty and Registration Card
2	Plastic Screwdrivers
4	Rubber Feet

Antenna Information

Antenna Connection

The base station is supplied with two (2) antennas. One 1/2-wave antenna for Transmit and one 1/2-wave for Receive. The antennas have TNC male connectors.

The frequency range of the antennas should match the receiver and transmitter of the base station. Match the color code on the antenna with the color code on the base station.

Attach the receive 1/2-wave antenna to the antenna input receptacle labeled "Receive" on the right side of the rear panel. The antenna should be vertically aligned.

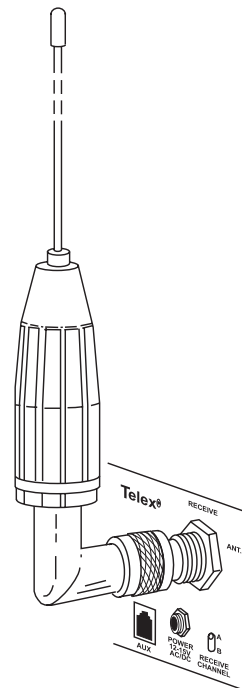

Figure 9
Attaching Receive 1/2-Wave Antenna

Attach the transmit 1/2-wave antenna to the antenna input receptacle labeled "Transmit" on the left side of the rear panel. The antenna should be vertically aligned.

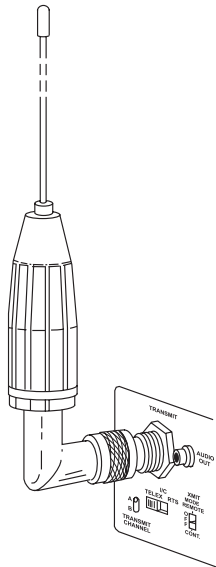
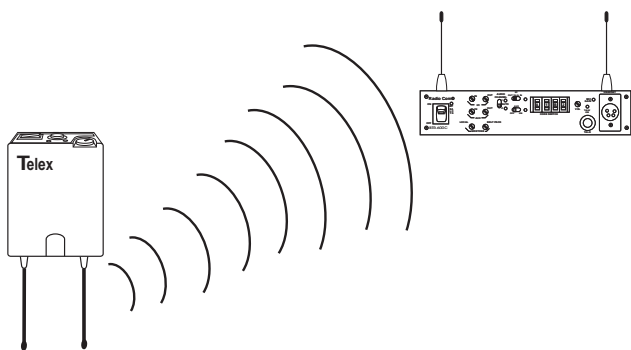

Figure 10
Attaching Transmit 1/2-Wave Antenna

Antenna Polarization

The Telex Wireless Intercom System is "Vertically Polarized". This means both the transmitting and receiving antennas should operate in the vertical position.



ANTENNAS MUST BE VERTICAL

Figure 11
Vertically Polarized Antenna

Distance between Antennas

The distance between the base station's receive and transmit antennas is not adjustable when the antennas are connected directly on the back of the unit.

The antennas can be removed for better signal path. A Telex coax assembly and/or a signal splitter/combiner with remote antennas may be required. See "Accessory" section for ordering information.

NOTE: If your base station is to be located in a shielded rack mount enclosure or other poor RF location, you must remove the 1/2-wave antennas with coax assemblies or use a splitter/combiner (SC-600) with special broad band antennas. See "Example System Configurations" section for a multiple unit system using a SC600 and broad band antennas.

Antenna Placement

Proper antenna placement probably has the most effect on your TELEX Wireless Intercom System's overall performance. The following suggestions will result in optimum performance.

Proper placement of the beltpack can be critical. The antennas should be in the open. Bending the antennas up and placing the beltpack in a pocket, etc., will reduce system distance.

It is suggested that the unit be worn on the belt or pocket with both antenna's hung vertically for best operating range and performance.

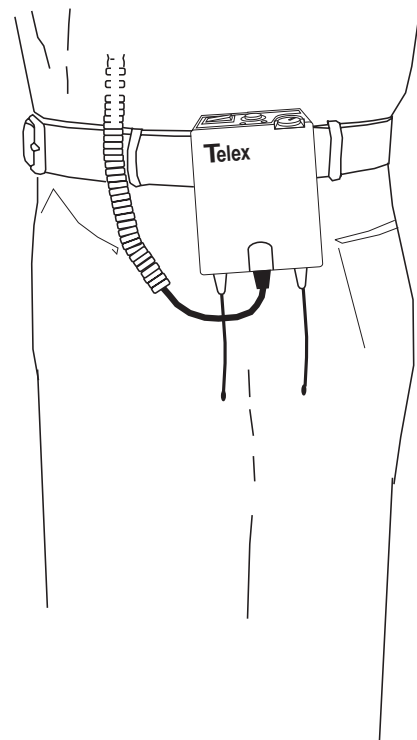

Figure 12
Proper Dressing of the Antennas

Keep the distance between the BTR and the TR as short as possible. The greater the distance, the weaker the signal. Make sure the “signal paths” between the BTR and TR are unobstructed. You should be able to visibly locate the antennas at all times for best performance.

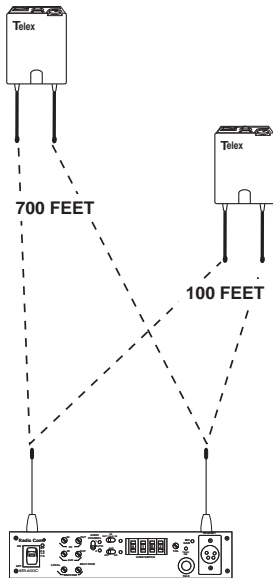

Figure 13
Distance Between base station and beltack

Attempting to operate the wireless intercom system through or around walls, ceilings, metal objects, etc. will reduce system range and performance.

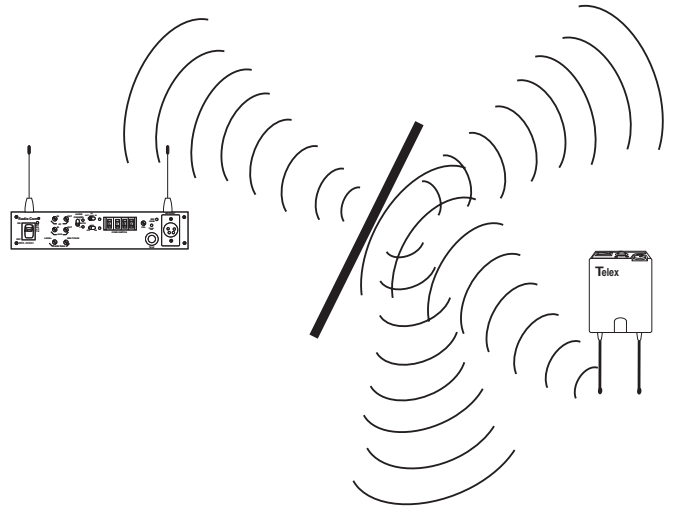

Figure 15
Operating System Near Obstructions

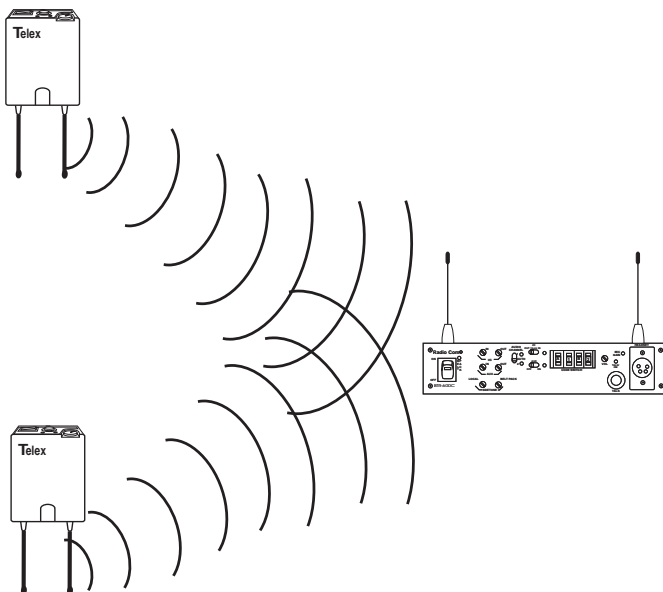

Figure 14
Keeping Site Clear to Antenna

DO NOT - mount the base station 1/2-wave antennas on, or next to metal, such as beams, walls with metal studs, equipment racks, etc. This also applies to the antennas when assembled directly to the Base Station. This will “detune” the antennas which can result in noise or loss of RF signal at the Base Station, See Figure 15.

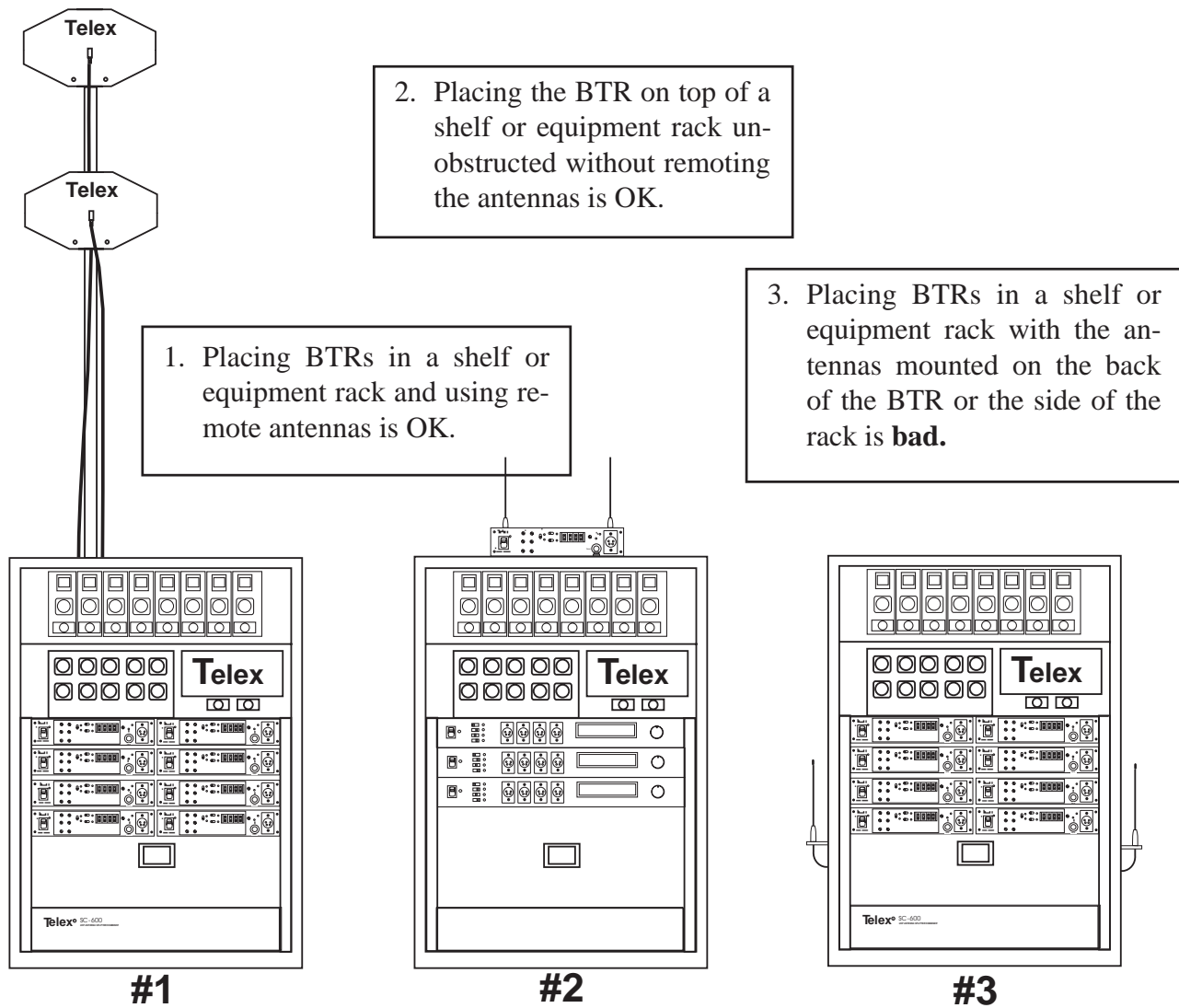

Figure 16
Antenna Placement

Improving Reception and Increasing Range

Keeping the distance from the base station and beltpack as short, and unobstructed as possible will produce the most reliable performance.

The base station is supplied with two antennas. This should provide satisfactory system performance in most applications. System range can be enhanced by remoting the 1/2-wave antennas.

If a multiple base station system is being configured, it is best to use a splitter/combiner (SC-600) with remote antennas for the best performance.

Base Station Set-Up

Location

Locate the base station on a level surface with the rear of the unit facing you. See "Antenna Information" section for more information on choosing a location.

Rack Mounting

Two kits are available for rack mounting the base station. The first kit rack mounts a single base station in a 19" rack. The second kit rack mounts two base stations, side by side, in a 19" rack. Instructions are included in the rack mount kits. Refer to the "Accessories" section for rack mount part numbers.

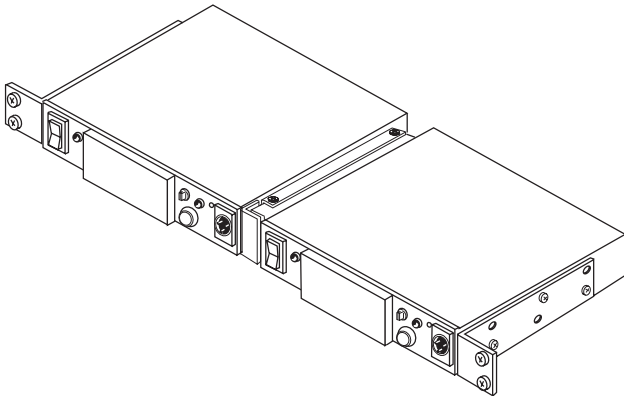

Figure 17
Attaching Brackets for Rack Mounting

Local Headset Connection

Insert the headset into the 4 pin XLR connector on the front panel. See the headset connection diagram (Figure 2) if other than a Telex Headset is used.

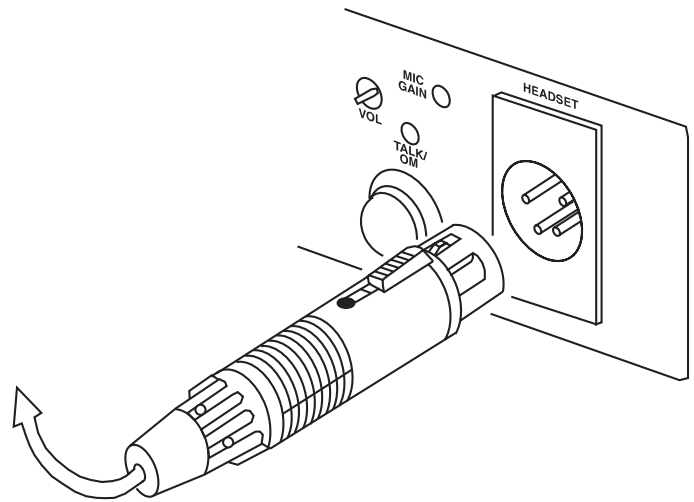

Figure 18
Connecting Headset to the Base Station

RF Transmit/Receive Channel Switches

Allows the user to select which of the two RF channels the unit is on. The transmit channel selected, either "A" or "B", is the frequency of the base station's transmitter.

The receiver channel selected, either "A" or "B", is the frequency of the base station's receiver. The frequencies are listed on the bottom of the base station.

The base station's transmit frequency must match the beltpack's receive frequency. The base station's receiver must match the beltpack's transmit frequency. Typically both base station switches are set to "A" or both to "B" and the beltpacks are set to the same.

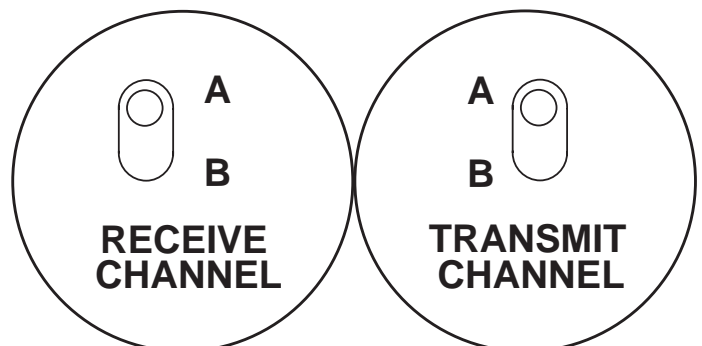

Figure 19
Receive and Transmit Switches

RF Transmit Mode Switch

Allows the operator to select three different types of transmitting modes; continuous transmit, transmitter off, or remote transmitter. For most operations, place the transmitter switch in the "CONT" position (Continuous mode).

In the **Continuous mode** the RF transmitter will be on at all times regardless of whether the portables are on or not.

In the **Remote mode**, the only time the base can transmit is when a portable unit is turned on.

In the **Off mode** the base station will not transmit to the remote belt-packs. This mode might be used if the base is to be an intercom system monitor station only.

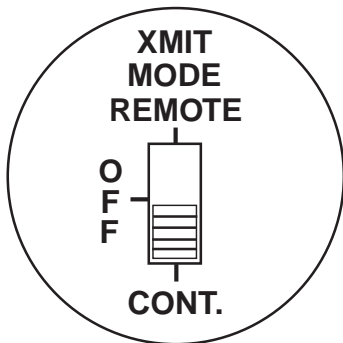

Figure 20
Transmit Switch

Intercom Type Switch

Set for Telex or RTS Type intercom systems.

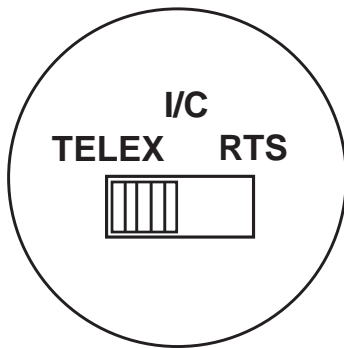

Figure 21
Intercom Select Switch

Dual Listen Switches

These two switches allow the mixing of the intercom channels. The mixing of audio channels occurs locally, only at the base station and its belt-pack. The switches do not affect the audio in the intercom lines into the base station.

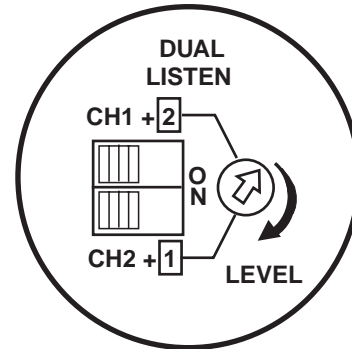

Figure 22
Dual Listen Switches

CH1 + 2 Switch = OFF
CH2 + 1 Switch = OFF

The two intercom audios are isolated. Audio channel one cannot be heard on channel two and vice versa.

CH1 + 2 Switch = ON
CH2 + 1 Switch = OFF

Audio channel two will be mixed into audio channel one. The volume of the mix of channel two as heard in audio channel one may be controlled by the level control.

CH1 + 2 Switch = OFF
CH2 + 1 Switch = ON

Audio channel one will be mixed into audio channel two. The volume of the mix of channel one as heard in audio channel two may be controlled by the level control.

CH1 + 2 Switch = ON
CH2 + 1 Switch = ON

Both audio channels are mixed into one another. The level of the other channel may be heard at the volume set by the level control.

Audio Channel Switch

Intercom Type Set to Telex

Selects either "IC 1 or 2" (and corresponding pins on "IC Loop-thru"). In "Auto" position the switch allows selection of channels 1 or 2 from the beltack.



Figure 23
Audio Channel Switch

Intercom Type Set to RTS

Selects RTS channel 1 or 2 on both I/C jacks (and corresponding Pins on "I/C Loop-thru"). In "Auto" position the switch allows selection of channels 1 or 2 from the beltack.

Telex IN/OUT Switch

Intercom Type Set to Telex

Telex = OUT

Intercom is disconnected from the I/C jacks and corresponding "I/C Loop-thru" connector pins.

Telex = IN

Intercom is connected to I/C jacks and corresponding "I/C Loop-thru" connector pins.

Intercom Type Set to RTS

Setting of switch has no effect. All I/C jacks and corresponding "I/C Loop-thru" connector pins are active.

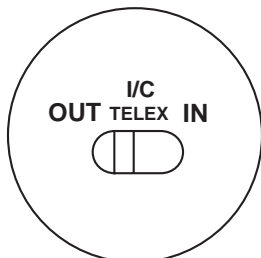

Figure 24
Telex In/Out Switch

Auxiliary Switch

Turns the "AUX" jack input audio on or off. The audio out is always sent to the "Aux" jack and is unaffected by the switch position.

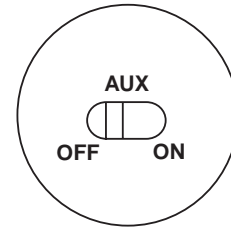

Figure 25
Auxiliary Switch

Auxiliary to I/C Switch (Program Audio)

This switch is located inside the base station. Its function is to provide a user with the ability to input a third channel of listen only audio via the "AUX" jack. This third channel of audio, usually called "Program Audio" is always heard regardless of which intercom channel the user is on. The program audio is heard only on the local base station and its beltack.

To gain access to the switch the base station's top cover must be taken off. Unscrew the six screws on the cover and lift off. The switch can be found between the two shielded compartments (Figure 27). The switch is labeled "Aux to IC" and should normally be left in the "ON" position. Unless using the "AUX" jack for program audio input. Switch to the "OFF" position if inputting program audio. The switch now disables auxiliary input audio from being placed on the intercom system but can be heard locally.

The auxiliary ON/OFF switch must be set to "ON" to enable input audio through the auxiliary port. The level of the program audio as heard in the background of the audio channel currently switch to is controlled via the "AUX IN" level control on the front panel.

Code Switch (BTR-600C Only)

Allows the operator to select over 65,000 cipher codes. The beltack's code must match the base station's code for audio recovery. Any combination of letters and/or numbers may be selected except 0000. The data is unencrypted when the setting is 0000.

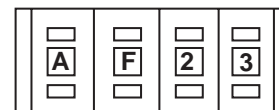

Figure 26
Code Switch

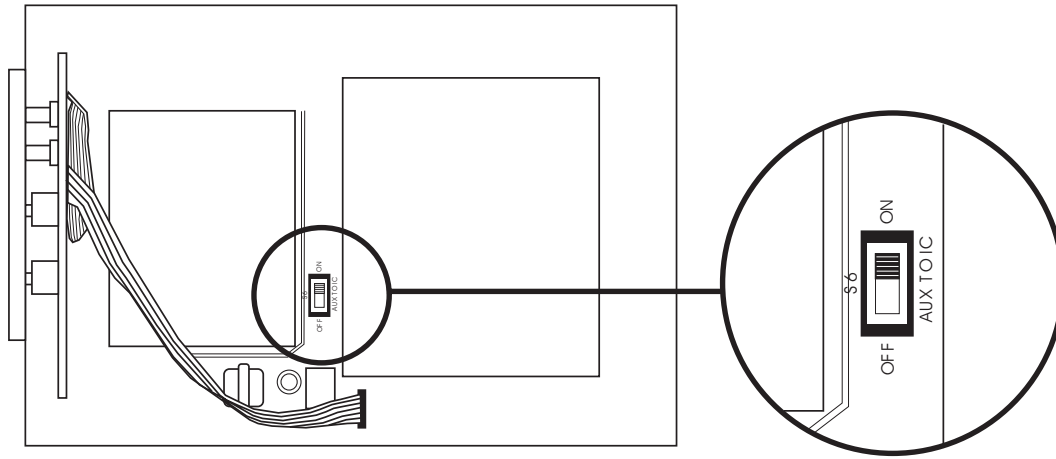

Figure 27
Auxiliary to I/C Switch

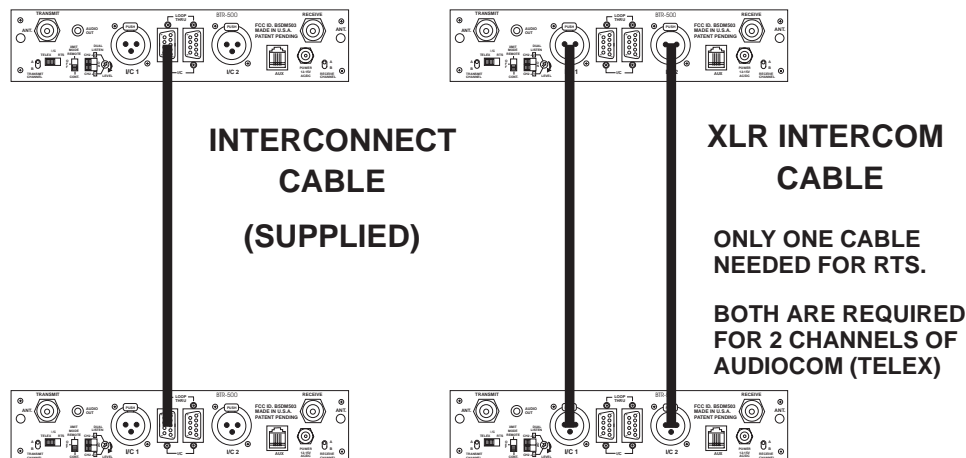

Figure 28
Connecting Base Stations Together

Interconnection to a Hard-Wired Intercom System

The Radiocom wireless system can be integrated into Audiocom (Telex) intercom systems and most existing wired intercom systems including RTS and Clear-Com.

Connect the intercom cable to the back of the base station. The intercom system may be connected to the base station via the XLR, D-Sub, or Aux connector in the rear of the unit. Audiocom, RTS and Clear-Com intercom systems use either the XLR or D-Sub connector. RTS Matrix intercom systems typically use the Aux connector. Example configurations of the two most popular intercom systems are shown in Figures 29 and 30.

NOTE: It is not recommended to interface an intercom system thru the “Aux” jack while at the same time having a different intercom system connected to the XLR or D-Subs.

It is recommended that Clear-Com intercom systems be interfaced to the base station through the use of CCB-1 Adapters. These adapters convert Clear-Com intercom signals to Telex intercom signals and vice versa. See “Accessories” for more information.

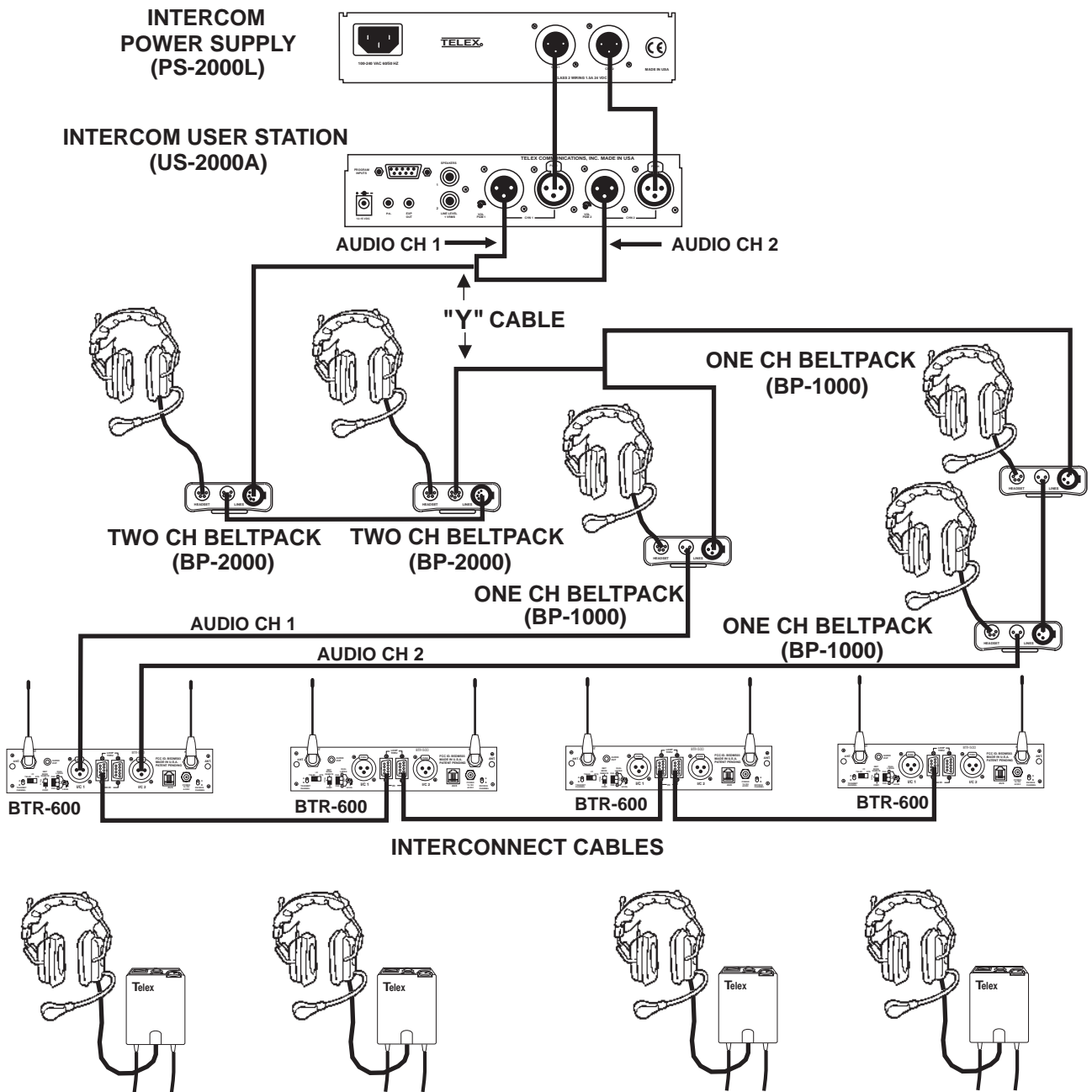

Figure 29
Example Interface to an Audiocom (Telex) Intercom System

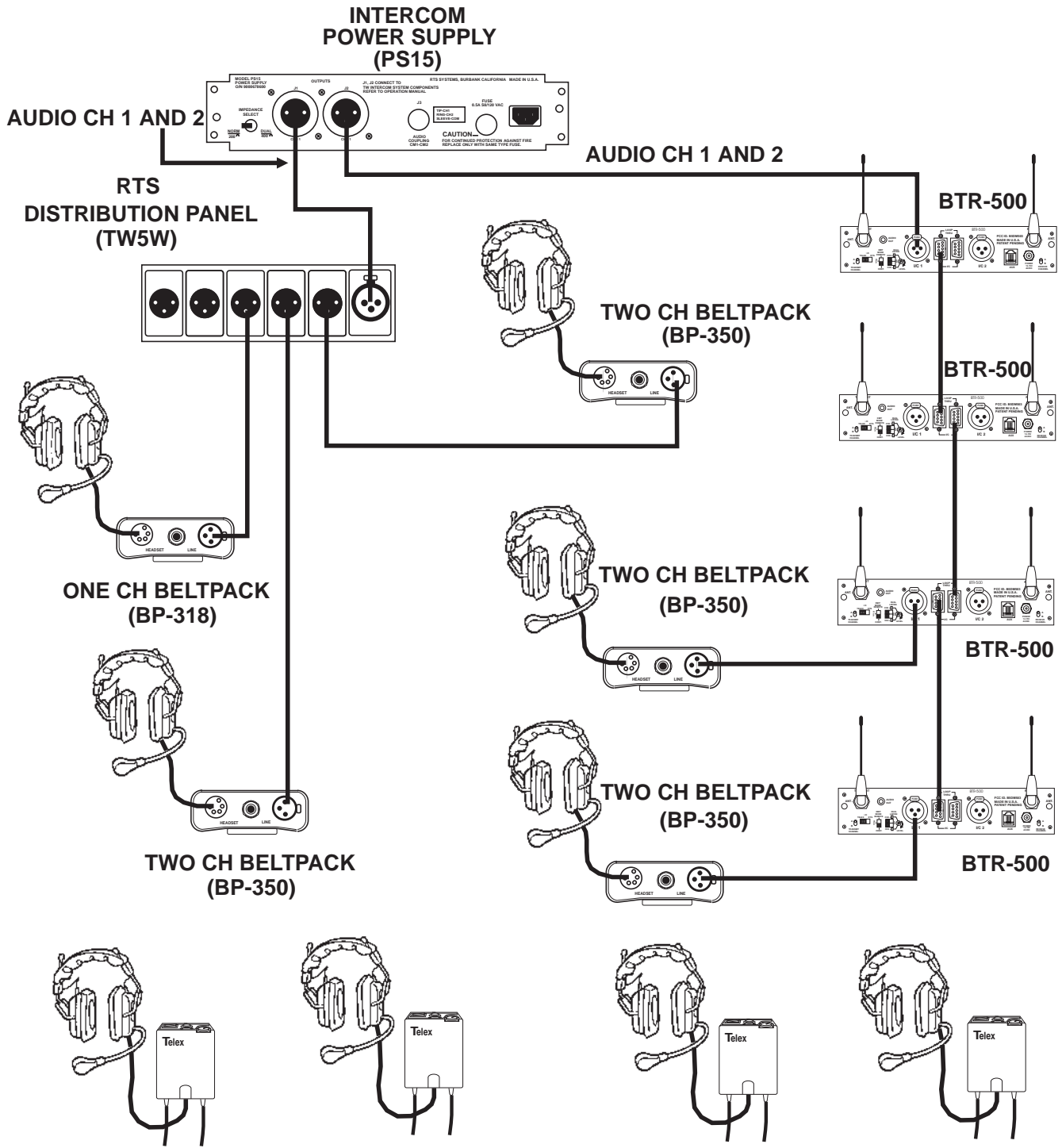

Figure 30
Example Interface to an RTS Intercom System

Auxiliary Audio Connection

The 6 pin telephone jack (RJ-11) may be used to supply audio into and out of the base station. RTS Matrix type intercoms may be interfaced to the base station through this jack.

Since audio is not “Channelized” through this jack, the audio channel switch has no effect on the audio passed through the jack. The audio will be heard on both channels 1 and 2 equally, audio generated by the BTR on channels 1 or 2 will be sent to the Auxiliary Jack.

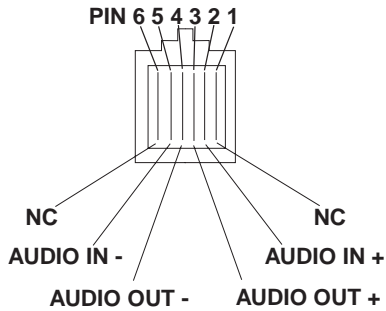

Figure 31
Auxiliary Jack

Power Connection

Insure the Power ON/OFF Switch on the front of the base station is in the “OFF” position. Connect the supplied AC power supply cord to the receiver at the socket labeled “POWER”. Connect the power supply unit to an AC outlet supplying 105 to 125 VAC, 60 Hz.

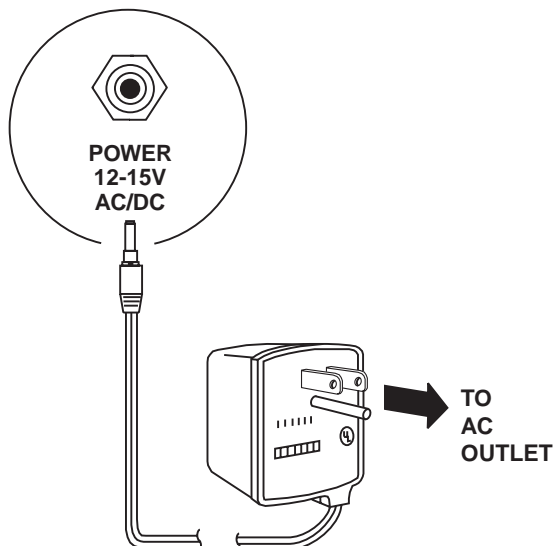

Figure 32
Connecting the Power Supply

Dummy Load

In the case where a wired intercom will not be used with the base station or only one of the audio channels are connected to the unit, it is important that the dummy load(s) (supplied) be installed.

I/C Switch = Set for Telex

Telex dummy loads should be plugged into both XLR ports if a wired Telex intercom system is not being used. A single Telex dummy load should be plugged into the unused channel's XLR port if only one channel is connected to an intercom system.

I/C Switch = Set for RTS

RTS dummy load should be plugged into one of the XLR ports if an RTS intercom system is not being used.

NOTE: If the dummy load is not placed properly, an annoying squeal may result that may cause damage to the ears.

Beltpack Set-Up

Headset Connection

Insert the headset/microphone into the connector on the bottom on the unit. See the headset connection diagram (Figure 8) if a unit other than Telex headset is used.

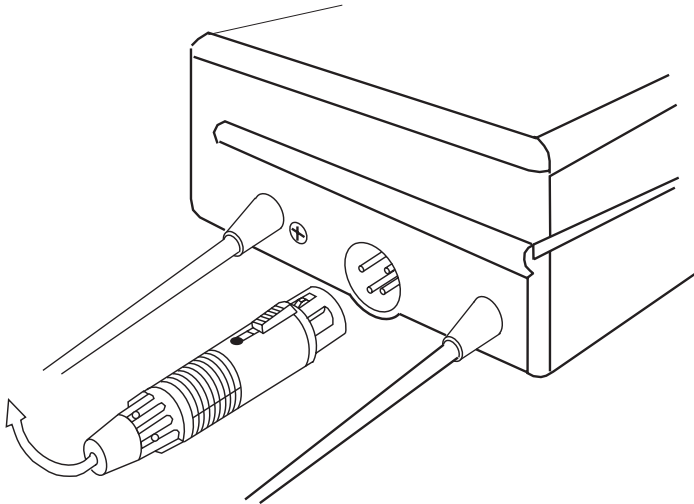

Figure 33
Connecting Headset

RF Transmit/Receive Channel Switches

Allows the user to select which of the two RF channels the unit is on. The transmit channel selected, either “A” or “B”, is the frequency of the beltpack’s transmitter.

The receiver channel selected, either “A” or “B”, is the frequency the beltpack’s receiver is at. The frequencies are listed on the label which is located under the beltpack’s battery pack.

The base station’s transmit frequency must match the beltpack’s receive frequency. Also the base station’s receiver must match the beltpack’s transmit frequency. Typically the base station switches are both set to “A” or both to “B” and the beltpacks are set to match.

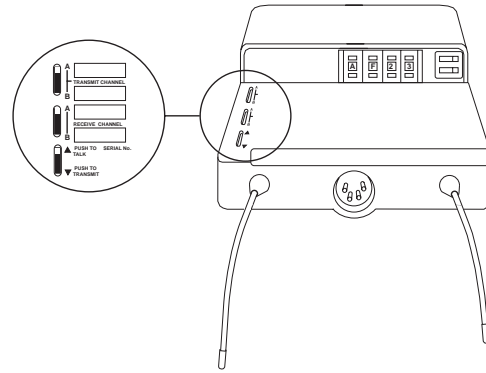

Figure 34
RF Channel Switches and RF Transmit Mode Switch

RF Transmit Mode Switch

Allows the operator to select two different types of transmitting modes; Push-to-talk or Push-to-transmit. For most operations, place the transmitter switch in the “Push-to-talk” mode.

In the “Push-to-talk” mode the RF transmitter will be on at all times regardless of whether the talk switch is on or off.

In the “Push-to-transmit” mode, the transmitter will be on only when the talk button is activated. The transmitter will be turned off when the talk button is deactivated.

Code Switch (TR-600C Only)

Allows the operator to select over 65,000 cipher codes. The beltpack’s code must match the base station’s code for audio recovery. Any combination of letters and/or numbers may be selected except 0000. The data is unencrypted when the setting is 0000.

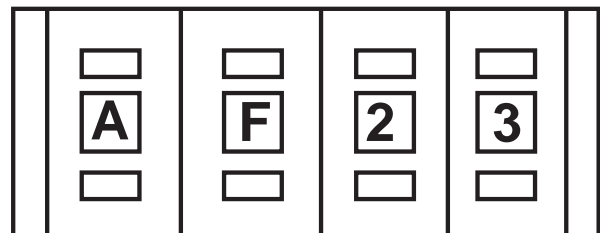
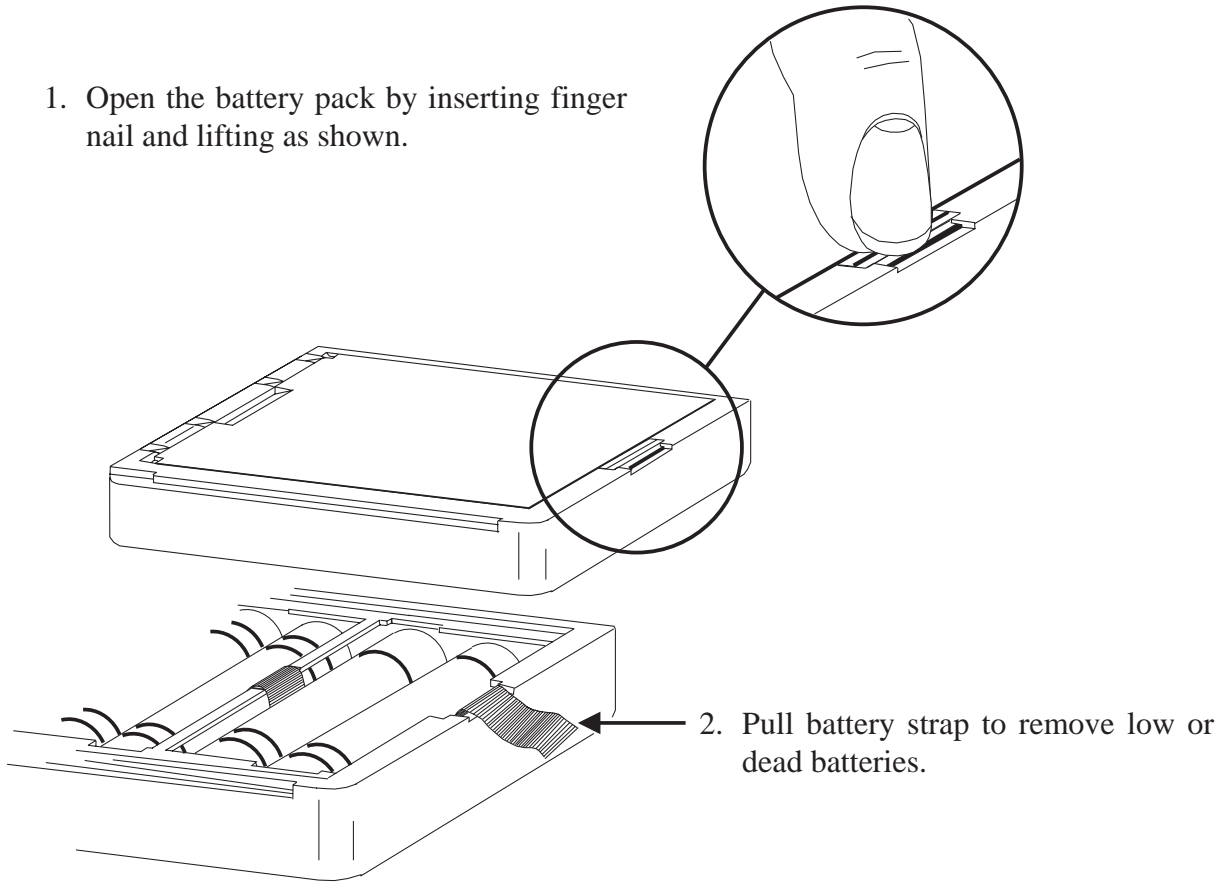

Figure 35
Code Switch

Battery Installation

Insure that the OFF/ON volume control knob is turned OFF. Press down the battery release latch and remove battery pack. Pack slides off in opposite direction. Replace batteries as follows:

1. Open the battery pack by inserting finger nail and lifting as shown.



3. Load new batteries with negative end against the spring.



4. Start loading at hinged end of case.

5. Be sure strap goes under batteries and over the top of the ribs.

6. Tuck end of strap under door when closing.

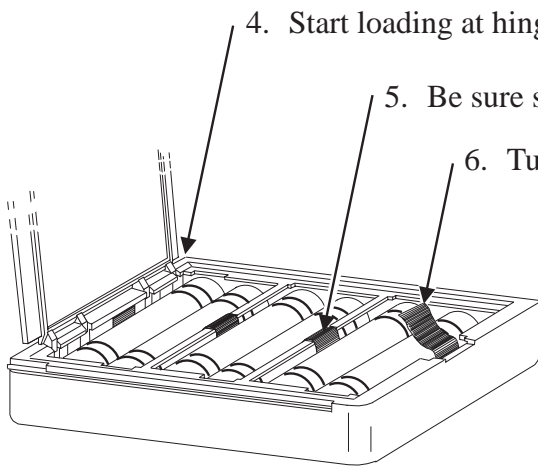

Figure 36
Battery Installation

Pre-Walk-Thru Checklist

Following the instructions fully to this point you have successfully completed the following checklist:

- Located the base station properly.
- Connected power to base station transceiver.
- Connected the 1/2-wave antennas to the base station. Check frequency range of the antenna with the frequency of the base station by correctly matching color codes.
- For a large system in which a splitter/combiner (SC-600) is used, make sure the antenna cables are connected to the correct ports and that the main antennas are connected to the marked SC-600 ports.
- Set RF transmit and receive switches on the base station(s) to match their respective beltacks.
- Set transmit mode switch on base station.
- Set wired intercom type correctly.
- Set audio channel correctly.
- Set Telex switch properly.
- Set Code Switch to a unique code that matches the beltack. (BTR-600C only)
- Connected headsets to base stations (if needed) and all beltacks.
- Connected the base station to any auxiliary audio, intercom, or external speaker if needed.
- Installed batteries in the beltack.
- If you missed any of the above instructions, go back and complete that instruction before going on.

System Operation

Base Station Operation

Power

If you have followed the instructions until this point you should now be ready to turn both the beltpack and the base station "ON"

Place the power switch on the base station in the "ON" position. The green power on indicator LED should illuminate.

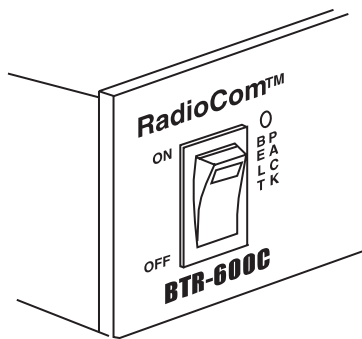

Figure 37
Base Station Power Switch

Push-to-Talk/Lock-to-Talk Switch

To enable the talk function on the base station press and hold down on the talk button and begin talking. Releasing the talk button will discontinue the microphone audio. For continuous talk, quickly press and release the talk button. This enables the talk function as long as you want. To release the talk function press and release the talk button once more and the talk function will cease.

NOTE: The talk LED will be illuminated wherever the talk function is activated.

Local Headset Volume

Adjust the volume control on the base station by rotating the Volume control either clockwise or counterclockwise as required for comfortable listening volume.

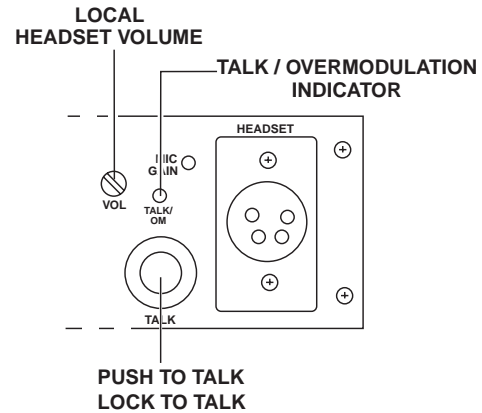

Figure 38
Push-to-Talk/Lock-to-Talk Switch and Local Headset Volume

Microphone Gain

The microphone gain of the local headset may need to be adjusted for various audio conditions. The talk/overmodulation (OM) LED should be green if the local headset microphone has been activated. This LED will turn red when Mic Gain is too high and will need to be turned down. If the LED does not flash red at all and the audio is low, the gain may need to be turned up. The gain should be adjusted so the LED flashes red only on loudest speech.

Using the plastic screwdriver (supplied), adjust the control appropriately. Note that the volume heard can also be adjusted by changing the spacing between the microphone and your mouth.

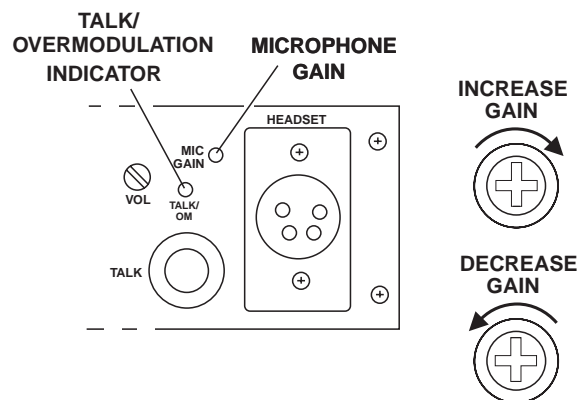

Figure 39
Adjusting Microphone Gain

Dual Listen Level

This control is related to the dual listen switches. It controls the level of the audio mix. For more information on the dual listen switches, refer to the "Base Station Set-Up" section.

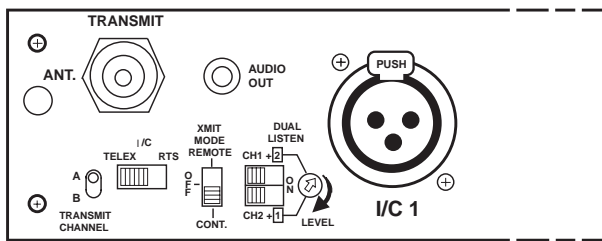

Figure 40
Dual Listen Level Control

Intercom Level

I/C IN

Adjusts the level of the Intercom system's audio into the base station. The Intercom "IN" control should be adjusted so the intercom LED flashes red on loudest speech over the intercom system.

I/C OUT

Adjusts the level of the base station's audio out to the intercom system. The intercom "OUT" control should be adjusted so that its audio on the intercom system is equal in level to the other intercom devices on the intercom system. A way to adjust this level is to have someone talk into the base station with a local headset while someone else listens to the audio over the intercom system via another intercom device.

Auxiliary Level

These controls should be placed fully counter-clockwise unless the Aux Jack is being used. Noise can be added to the system if these controls are turned up without a connection to the Aux. Jack.

Aux IN

Adjusts the level of the auxiliary input audio to the base station. The auxiliary "IN" control should be adjusted so that the LED flashes red on loudest speech. The Aux. switch controls whether the base station's auxiliary input audio is "ON" or "OFF".

Aux OUT

Adjusts the level of the base station's audio out to the auxiliary connector. The auxiliary "OUT" control should be adjusted so that its audio is equal to other devices on the auxiliary system. The base station's audio is always supplied to the auxiliary jack regardless of the auxiliary switch position.

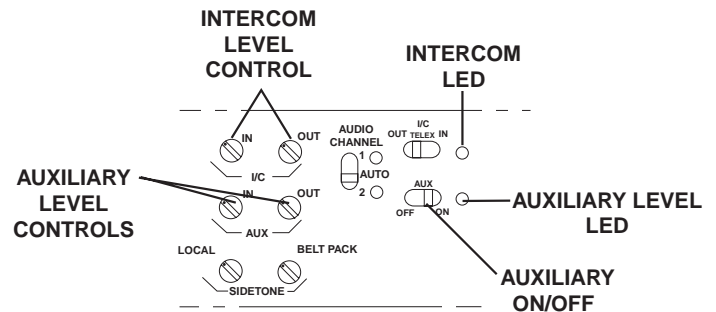

Figure 41
Intercom Level Controls, Auxiliary Level Controls, and Sidetone Level Controls

Sidetone Level

Local Sidetone

This control adjusts the voice feedback to the earphone of a headset plugged into the base station.

Beltpack Sidetone

The beltpack control adjusts the voice feedback to the earphone of the beltpack's headset.

NOTE: "Mirror Image" beltpacks have the ability to communicate beltpack to beltpack direct. The beltpack sidetone on this version is controlled by a level control on the beltpack, see Figure 51. If a base station is used with one of these special beltpacks, then its beltpack sidetone control would have no effect on the beltpack.

Beltpack Operation

Power/Local Headset Volume

You should now be ready to turn the beltpack "ON". Rotate the OFF/ON Volume Control Switch on the beltpack clockwise to turn the unit on.

ON/OFF SWITCH AND VOLUME CONTROL

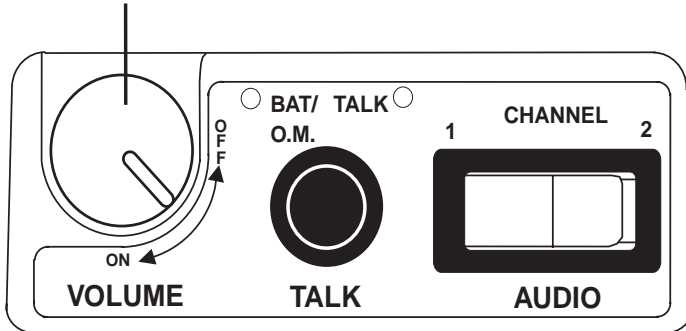

Figure 42
Off/On Volume Control Switch

Battery Check

As you rotate the OFF/ON volume control knob clockwise to turn the unit on, note that the battery LED (Labeled "BAT/O.M.") should flash one time on good batteries. Poor batteries will cause the LED to be illuminated continuously and a bad or unusable battery will not cause any illumination at all.

LOW BATTERY AND OVERMODULATION INDICATOR LED

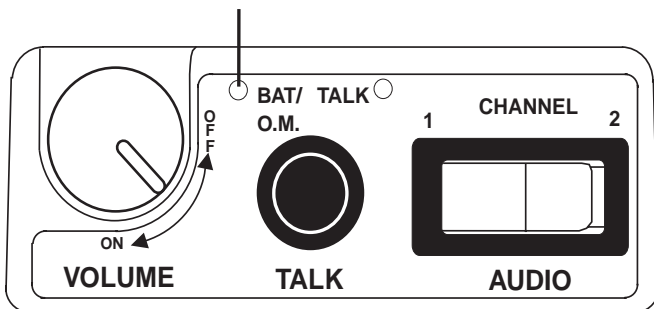

Figure 43
Low Battery and Overmodulation Indicator LED

Push-to-Talk/Lock-to-Talk

To enable the talk function on the beltpack press and hold down on the talk button and begin talking. Releasing the talk button will discontinue the microphone audio. For continuous talk, quickly press and release the talk button. This locks on the talk function. To release the talk function press and release the talk button once.

NOTE: The talk LED will be illuminated whenever the talk function is activated.

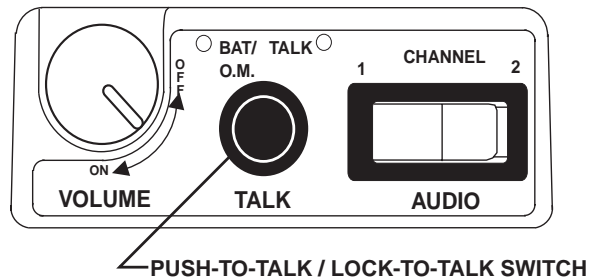

Figure 44
Push-to-Talk/Lock-to-Talk Switch

Microphone Gain

The microphone gain of the beltpack's headset may need to be adjusted for various audio conditions. The Battery/Overmodulation (O.M.) LED will flash red when Mic Gain is too high and will need to be turned down. If the LED does not flash red at all, and the audio from the unit sounds low, then the gain may need to be turned up. The gain should be adjusted so the LED flashes red only on loudest speech.

Using the plastic screwdriver (supplied), adjust the control appropriately. Note that the volume heard can also be adjusted by changing the spacing between the microphone and your mouth.

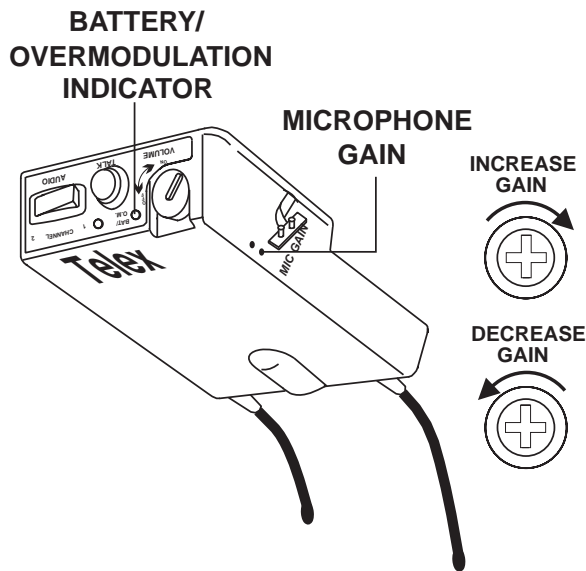

Figure 45
Microphone Gain

Sidetone Level

Regular TR beltpacks have their sidetone control located on their respective base stations (See the sidetone level part of the base station "Operation Section").

Specially ordered beltpack to beltpack (Mirror Image) direct communication units have their sidetone controlled by a control on the beltpack. To adjust the voice feedback to the earphone (sidetone) of these units, simply turn the control until the sidetone is at a comfortable level.

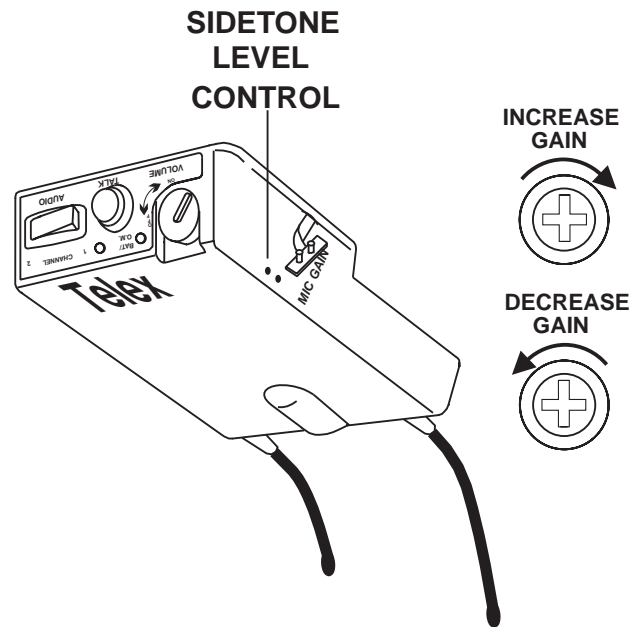

Figure 46
Sidetone Level Control

Example System Configurations

Single Base Station Audiocom (Telex) System

The audio out RCA jack on the back of this unit is used for the public address system. The unused Audiocom channel must be terminated to avoid loud feedback if audio channel two was switched to by the beltpack.

The audio out of the base station's RCA jack is the audio channel currently switched to at the BTR-500.

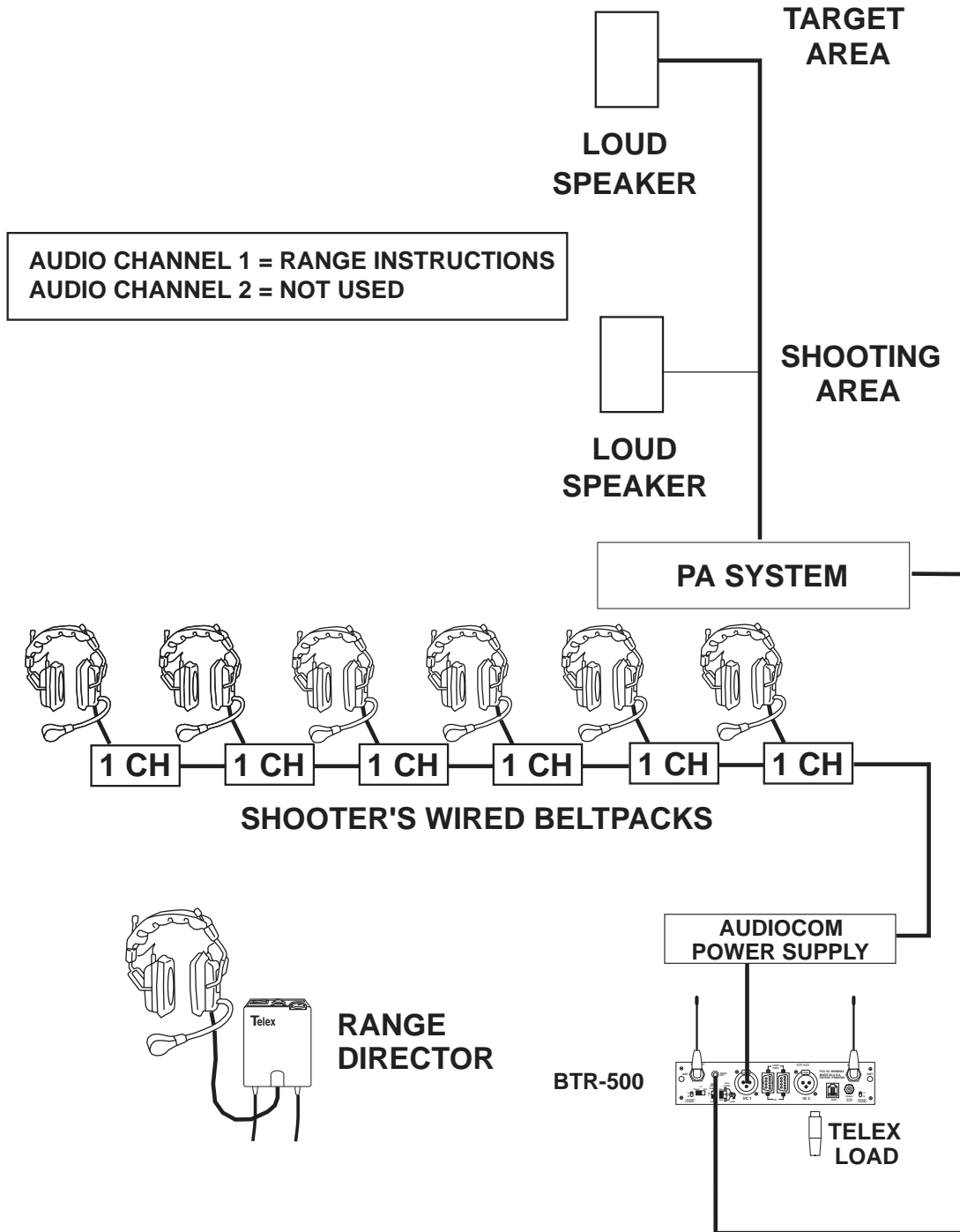

Figure 47
Example single BTR-500 Audiocom System used at a Shooting Range

Single Base Station RTS System

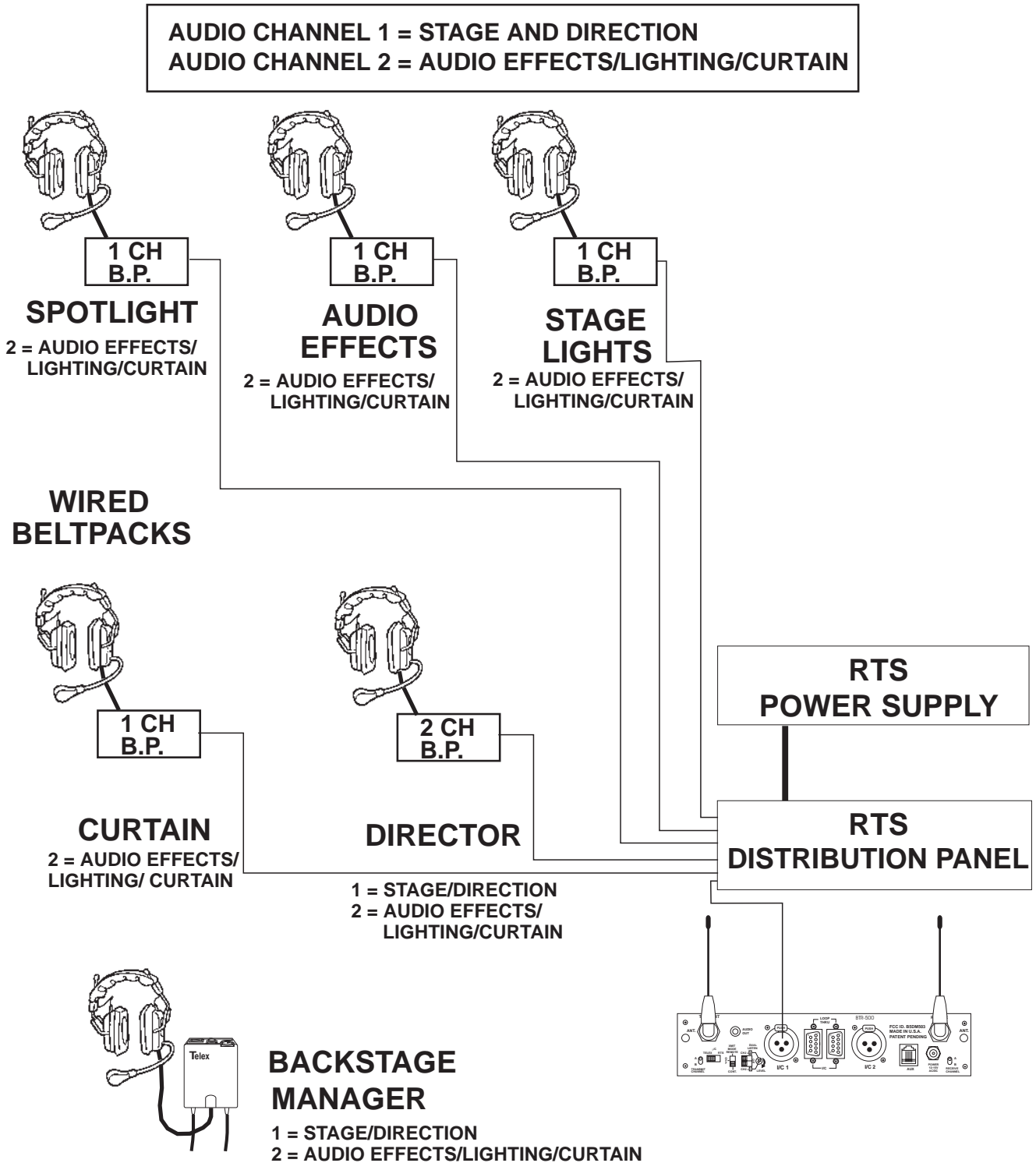

Figure 48
Example Single BTR-500 RTS System used at a Small Play Production

Six Base Station RTS System

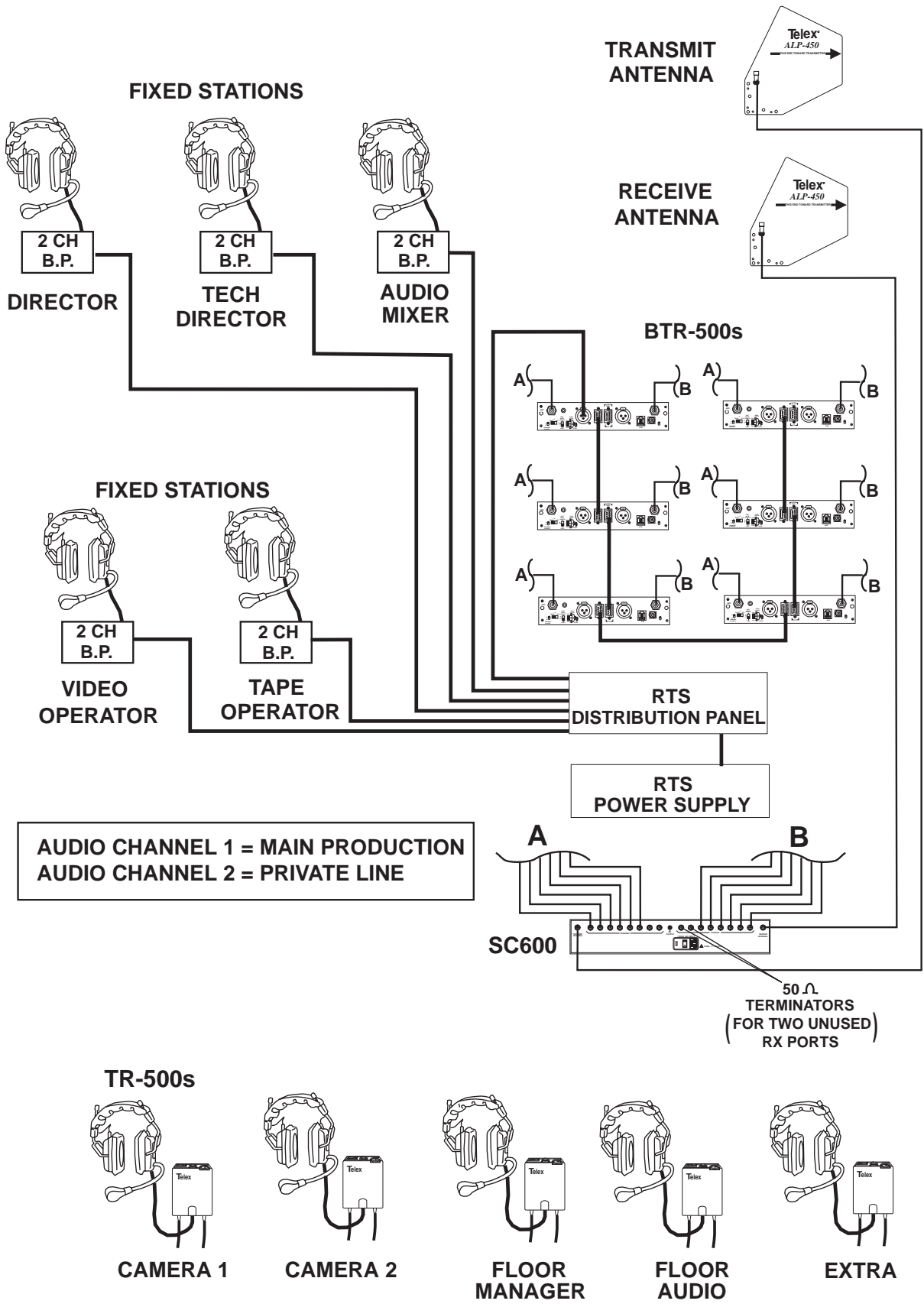

Figure 49
Example of Six BTR-500 RTS Systems used by a Production Unit

Eight Base Station Telex System

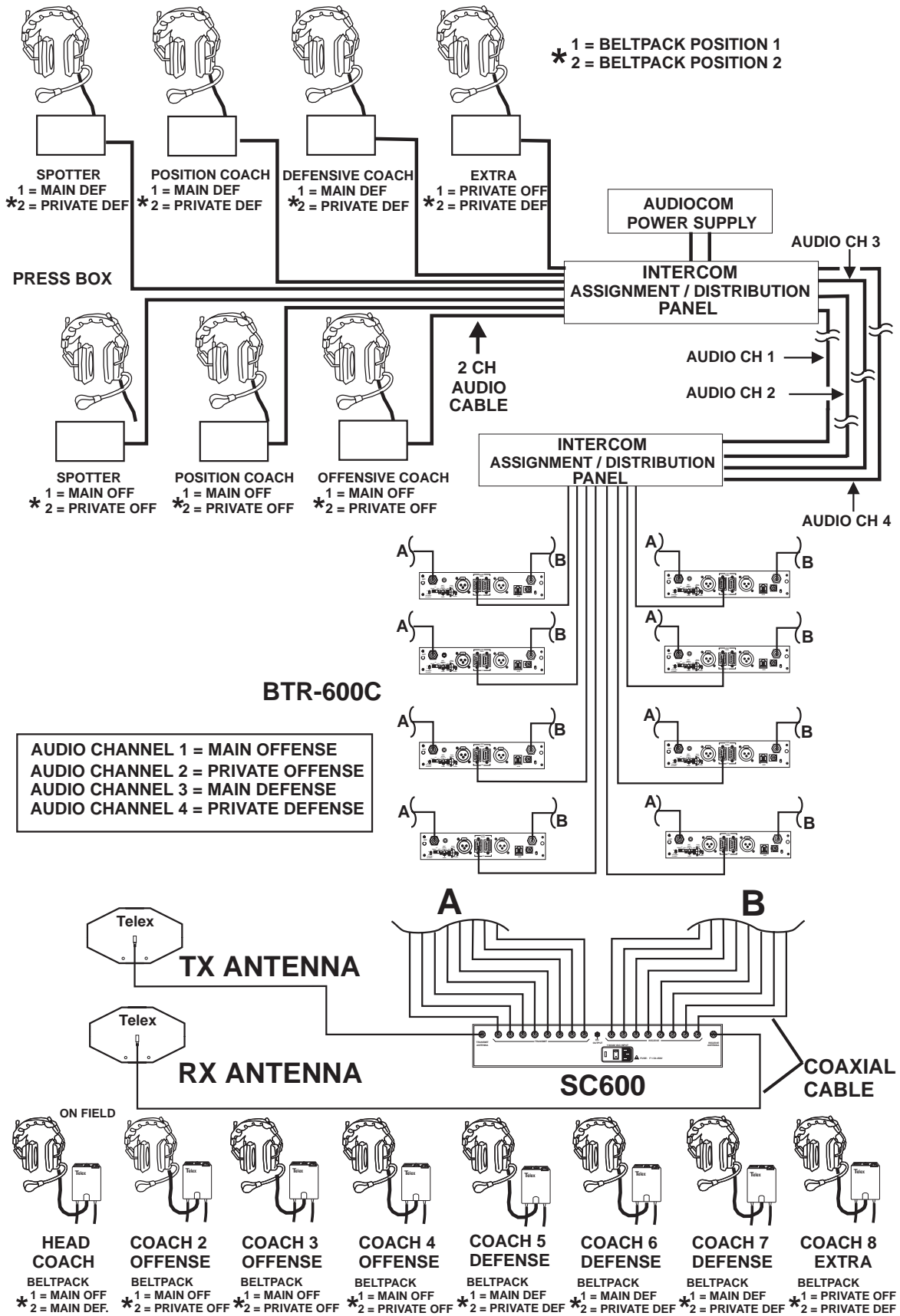

Figure 50

Example of an Eight BTR-600C Audiocom(Telex) System being used by a Football Team

Beltpack to Beltpack System

The following is an example of a beltpack to beltpack system. The two operators need to be in constant, full-duplex communication with each other in a noisy paper press environment.

Single Beltpack to Single Beltpack System



Figure 51
Example of a TR-500 System used at a Publishing Firm

System Walk-Thru

Now that you have successfully “set up” your Telex Wireless Intercom System and turned on any auxiliary equipment you are ready to test the overall performance by “Walking” the Telex system through the areas in which you will be using it.

Before you begin your walk-thru, check the following:



Beltpack Battery Check.



Set microphone gain in both the beltpack and the base station.



Check that the push-to-talk switch is engaged in the lock-to-talk position. LED will be illuminated.



I/C Level “IN” and “OUT” are set to an appropriate level and not turned to zero.



Sidetone local and beltpack levels are set to an appropriate level.

The “system walk-thru” can detect problems of weak signal strength caused by:

- Poor antenna location
- Wrong antenna for receiver and/or transmitter.
- RF “Trouble Spots”
- Operating distance beyond system capability.
- Old or used batteries in the TR-500/600

Under normal conditions the indicator LED on the base station’s beltpack should always be lit when their beltpacks are transmitting. “Weak Signal” conditions will result in flashing, or the complete loss of this Carrier LED.

In 99% of all instances you will set up your Telex Wireless Intercom System, walk it through and achieve error-free performance. If in the rare instance your Telex system does not “pass” during your walk-thru evaluation, refer to the section of this manual which deals with System Troubleshooting.

TROUBLESHOOTING

Reread the sections of this manual to make sure you have completed system set-up properly

If you are unable to solve the problem, contact the dealer from whom you purchased the system for assistance.

PROBLEM	SOLUTION
DISTORTION - System's audio quality seems distorted at medium to high input levels.	Reduce microphone gain by adjusting microphone gain control.
HISS - System seems to produce a "hiss" which is undesirable.	Check the gain setting on all beltacks and the base. They may be too low.
LOW OUTPUT - System produces a low output level.	Check the gain setting on both the beltacks and the base. They may be too low.
FEEDBACK - Moving around area of use produces "squeal" or "howl" in various locations using ext. speakers.	Reduce the gain settings on both the beltacks and the base. They may be too high.
DROPOUTS - When moving around the area of use there seems to be locations where the signal "swooshes" or completely disappears.	Make sure both antennas on the base are connected and follow the location suggestions. Change the location of the base unit and antennas or avoid the bad areas with the remote beltacks.
INTERFERENCE - System picks up signals other than wireless Intercoms.	Make sure the Telex beltack is turned on - this will usually eliminate the interfering signal. If not using a beltack, make sure the transmit mode switch at the base is in the off position. If problems persist with the beltack on, you will probably need to change frequency channels. Make sure the base channel switch matches the beltack.
NO AUDIO from BASE or BELTPACK headsets.	Check Transmitter switch on base, use CONT or REMOTE position. Check push-to-talk function - is the switch ON. Make sure beltack batteries are OK.

Tech Tips

Codes Settings and the BTR600C

While the BTR-600C and corresponding TR-600C have over 65,000 different codes that may be selected by the user, there are actually over 16 million different codes in the units. The microprocessor in each base station and corresponding beltack has two unique numbers programmed into them from the factory. The external four code switch settings are used in conjunction with these two internal, non-accessible, numbers to encrypt and decrypt audio sent to and from the units.

Frequency Interaction

Unfortunately, radio frequency (RF) channels cannot be randomly selected for use in radio devices. They must be selected to avoid known frequencies in use, FCC restrictions on the location of devices, and even interference between your own RF devices. The channels selected by Telex for Radiocom systems are chosen to minimum possible interference. This is why it is always important to inform Telex about frequencies of other Radiocom or other RF devices that will be used with any additional Radiocom equipment ordered.

Microphone Gain Adjustment

The microphone gain controls on the base station and beltack are set to mid-levels by the factory. In most cases this setting will work fine and only on loudest speech will the overmodulation (OM) indicator light. However, in environments where the background noise is loud or the user has a strong/quiet voice, the gain control will need to be adjusted. In Figure 52 the gain is set correctly. The user's root-mean-square (RMS) sound level is well below the OM threshold and only on a few loud peaks does his or her voice flash the OM indicator light. Figure 53 displays the same gain setting as in Figure 52, but brought into a high noise environment. The user's voice now lights the OM indicator over half the time he or she speaks due to the higher noise plus the user speaking louder. The result on the system is distortion with possible "clipping" on louder speech. The microphone gain must be reduced. The same applies to a user with a powerful voice. If someone sets the system mic gain to their voice and user has a much stronger voice, then the gain will need to be reduced, even if the background noise is the same.

Always remember to set the microphone gain based on the situation and location in which the equipment will be used. If the equipment is used on the field during a football game, set the gain based upon a loud stadium, NOT the quiet stadium 2 hours before a game. If a production studio user has a quiet voice, set the gain to their voice and NOT the stage hand's loud voice who helped set up the system.

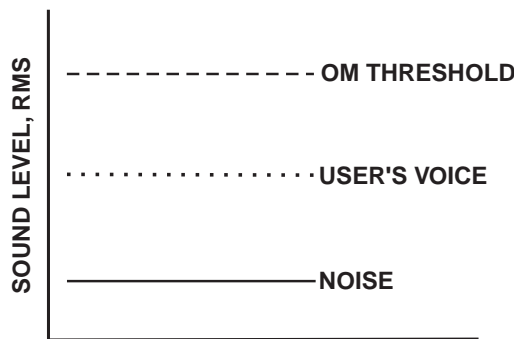

Figure 52
Low Noise Environment
Microphone Gain Set Correctly

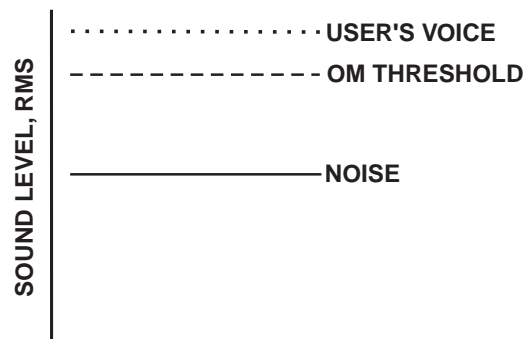

Figure 53
High Noise Environment
Microphone Gain Set Too High

Battery Information

Improper battery selection, use, installation and care are the cause of numerous wireless system failures.

Alkaline Batteries: Alkaline batteries such as Mallory's DURACELL® or Eveready's ENERGIZER® provide the most reliable operation in wireless transceivers. Typical battery life of fresh alkaline batteries is 12 hours. **The use of low cost carbon-zinc batteries is NOT recommended.**

Nickel-Metal Hydride Batteries: These batteries can save you money in the long run, as they can be recharged. Typical battery life is 8 to 9 hours, which is about 70% of the length of time alkaline batteries last.

Energizer® is a registered trademark of Union Carbide Corporation.
Duracell® is a registered trademark of Duracell Inc.

Intercom Systems Specifications

RTS

Input Impedance:200Ω
 Output Level:0.775 Vrms nominal
 Bridging Impedance:>10kΩ
 Call Signalling:
 Send:20kHz ±100 Hz, 240 mVrms
 Receive:20kHz ±800 Hz, 100 mVrms
 Power Voltage:28.0 VDC nominal

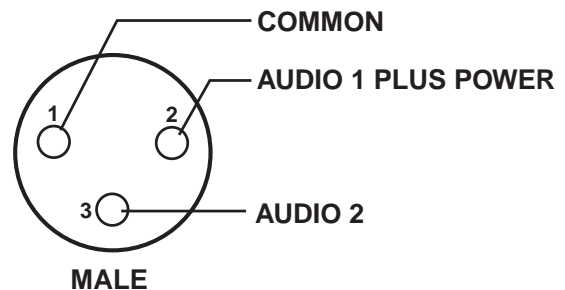

AudioCom/Telex

Input Impedance:300Ω
 Output Level:1.0 Vrms nominal
 Bridging Impedance:>10kΩ
 Call Signalling:
 Send:20kHz ±100 Hz, 0.5 mVrms
 Receive:20kHz ±800 Hz, 100 mVrms
 Power Voltage:24.0 VDC nominal

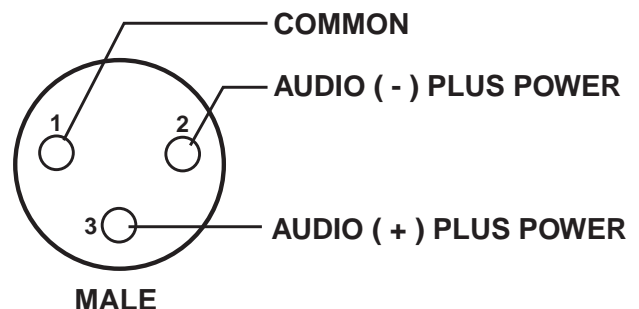

Clear-Com

Input Impedance:200Ω
 Output Level:200 Vrms nominal
 Bridging Impedance:>10kΩ
 Call Signalling:
 Send:12 ±3 VDC
 Receive:4 VDC Minimum
 Power Voltage:30.0 VDC nominal

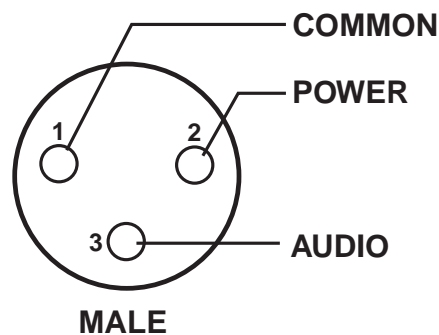

Accessories and Replacement Parts

ALP-600

520-760 MHz Bi-Directional Log Periodic Antenna
Includes mounting hardware and 10 feet (3 meters)
of coaxial cable with TNC Connectors

Order No. 878896

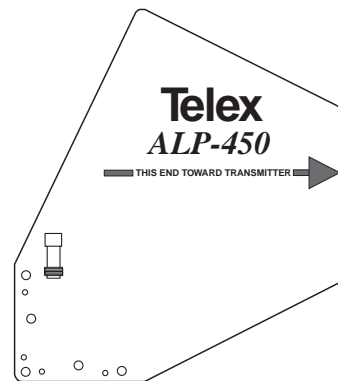
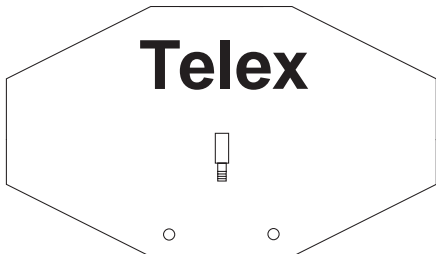

ALP-450

450-900 MHz Log Periodic Antenna
Includes mounting hardware and 10 feet (3 meters)
coaxial cable with TNC connectors

Order No. 71147000

Antenna Cables: Special low loss antenna cables
with TNC Connectors.

Model No.	Length	Order No.
CXU-10	10 Ft. (3 meter)	690419
CXU-25	25 Ft. (7.6 meter)	71151-025
CXU-50	50 Ft. (15 meter)	71151-050
CXU-75	75 Ft. (23 meter)	71151-075
CXU-100	100 Ft. (30 meter)	71151-100

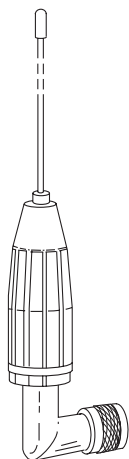

1/2-Wave Antenna

BTR Power SupplyPN 730127

BTR Intercom Patch CablePN 690412

BTR Intercom Dummy Load
Telex type.....PN 878935
RTS type.....PN 878990

TR Battery pack, alkaline
(batteries not included)PN 71215-000

TR Nickel Metal Hydride Battery pack
with "Smart Charger"PN 71215-200

TR Nickel Metal Hydride
Battery packPN 71215-002

SC600 Splitter/Combiner.....PN 71197-000

Single 19" Rack Mount KitPN 71081-006
Mounts one base station in a 19" rack

Dual 19" Rack Mount Kit.....PN 71081-007
Mounts two base stations, side by side
in a 19" rack

Signal Switch OptionPN 878811-1
This option allows the user of a beltback to re-
motely activate special relay contacts on a base
station

CCB-1 Interface Device
Interfaces Telex balanced to ClearCom
unbalanced. One CCB-1 is required for each au-
dio channel.

Order No. 96230-000

Model No.	Part No.	Band Color	Frequency
CLA-1	870658-1	Blue	520-564.9 MHz
CLA-2	870658-2	Yellow	565-614.9 MHz
CLA-3	870658-3	Red	615-659.9 MHz
CLA-4	870658-4	White	660-689.9 MHz
CLA-5	870658-5	Green	690-724.9 MHz
CLA-6	870658-6	Orange	725-760 MHz

CUSTOMER SERVICE INFORMATION

If your receiver or transmitter should need servicing, please contact:

Customer Service Department
TELEX COMMUNICATIONS, INC.
8601 East Cornhusker Highway,
P.O. Box 5579,
Lincoln, Nebraska 68505-5579 U.S.A.
Phone: (402) 467-5321 or 465-7021

All claims of defect or shortage should be sent to the above address. When returning items for service, you must provide date and proof of purchase, such as a copy of the sales receipt, to establish warranty. A letter should be included outlining all symptoms and claimed defects. Information on how the equipment was installed and used is very helpful. Please include your phone number and return address in case our service technicians need to contact you.

Units that have been modified cannot be accepted for repair.

Include all information requested by the Service Department. Then pack the unit as follows:

Check the unit to see that all parts and screws are in place. Then wrap it in heavy paper or put it in a plastic bag. If the original carton is not available, place the unit in a strong carton that is at least six inches bigger in all three dimensions than the unit. Fill the carton equally around the unit with resilient packing material (shredded paper, foam, etc.). Seal it with gummed paper tape, tie it with a strong cord, and ship it by prepaid express, United Parcel Service or insured parcel post to the Telex Service Department.

It is very important that the shipment be well-packed and fully insured. Damage claims must be settled between you and the carrier and this can delay repair and return of the unit to you.

Telex reserves the right to make changes in design and improvement on its product without assuming any obligation to install the same on any of its products previously manufactured. Further Telex reserves the right to ship new and/or improved products which are similar to the form, fit and function of products originally ordered.

FCC INFORMATION

The Telex BTR-500/600C and the TR-500/600C Transmitter/Receiver are Type Accepted under United States Federal Communications Commission Part 74. Licensing of Telex equipment is the User's responsibility and licensibility depends on the user's classification, users application, and frequency selected. Telex strongly urges the user to contact the appropriate telecommunications authority for any desired clarification.

CAUTION: Changes or modifications made by the user could void the user's authority to operate the equipment.

TELEX[®]

TELEX COMMUNICATIONS, INC. • 12000 Portland Ave. South, Burnsville, MN 55337.

PN 801567-2

JAN 2001

Made in U.S.A.

Free Manuals Download Website

<http://myh66.com>

<http://usermanuals.us>

<http://www.somanuals.com>

<http://www.4manuals.cc>

<http://www.manual-lib.com>

<http://www.404manual.com>

<http://www.luxmanual.com>

<http://aubethermostatmanual.com>

Golf course search by state

<http://golfingnear.com>

Email search by domain

<http://emailbydomain.com>

Auto manuals search

<http://auto.somanuals.com>

TV manuals search

<http://tv.somanuals.com>