

INSTALLATION AND MAINTENANCE INSTRUCTIONS

4HP16LT Series

Split System Heat Pump

Save these instructions for future reference

WARNING

The equipment covered in this manual is to be installed by trained and experienced service and installation technicians. Improper installation, modification, service, or use can cause electrical shock, fire, explosion, or other conditions which may cause personal injury, death, or property damage. Use appropriate safety gear including safety glasses and gloves when installing this equipment.

WARNING

Risk of electrical shock. Disconnect all remote power supplies before installing or servicing any portion of the system. Failure to disconnect power supplies can result in property damage, personal injury, or death.

WARNING

Installation and servicing of air conditioning equipment can be hazardous due to internal refrigerant pressure and live electrical components. Only trained and qualified service personnel should install or service this equipment. Installation and service performed by unqualified persons can result in property damage, personal injury, or death.

WARNING

Sharp metal edges can cause injury. When installing the unit, use care to avoid sharp edges.

TABLE OF CONTENTS

INSTALLATION	2
CONNECTION DIAGRAM	4
START-UP	13
OPERATION	18
MAINTENANCE	23

Manufactured By
Allied Air Enterprises, Inc.
A Lennox International Inc. Company
215 Metropolitan Drive
West Columbia, SC 29170



INSTALLATION

General

Read this entire instruction manual, as well as the instructions supplied in separate equipment, before starting the installation. Observe and follow all warnings, cautions, instructional labels, and tags. Failure to comply with these instructions could result in an unsafe condition and/or premature component failure.

These instructions are intended as a general guide only for use by qualified personnel and do not supersede any national or local codes in any way. The installation must comply with all provincial, state, and local codes as well as the National Electrical Code (U.S.) or Canadian Electrical Code (Canada). Compliance should be determined prior to installation.

4HP16LT condensing units use R410A which is an ozone-friendly HFC refrigerant. This unit must be installed with a matching indoor coil and line set. A filter drier approved for use with 410A is installed in the unit.

IMPORTANT: This product has been designed and manufactured to meet ENERGY STAR criteria for energy efficiency when matched with appropriate coil components. However, proper refrigerant charge and proper air flow are critical to achieve rated capacity and efficiency. Installation of this product should follow the manufacturer's refrigerant charging and air flow instructions. **Failure to confirm proper charge and airflow may reduce energy efficiency and shorten equipment life.**

When servicing or repairing HVAC components, ensure the fasteners are appropriately tightened. Table 1 shows torque values for fasteners.

Torque Table	
Fastener	Torque
Stem Caps	8 ft. lbs.
Service Port Caps	8 ft. lbs.
Sheet Metal Screws	16 in. lbs.
#8 Machine Screws	16 in. lbs.
#10 Machine Screws	28 in. lbs.
Compressor Bolts	90 in. lbs.

Table 1

Inspection of Shipment

Upon receipt of equipment, carefully inspect it for possible shipping damage. If damage is found, it should be noted

on the carrier's freight bill. Take special care to examine the unit inside the carton if the carton is damaged. Any concealed damage discovered should be reported to the last carrier immediately, preferably in writing, and should include a request for inspection by the carrier's agent.

If any damages are discovered and reported to the carrier **DO NOT INSTALL THE UNIT, as claim may be denied. Check the unit rating plate to confirm specifications are as ordered.**

Location of Unit

Outdoor units operate under a wide range of weather conditions; therefore, multiple factors must be considered when positioning the unit. The unit must be positioned to give adequate clearances for sufficient airflow and servicing. Refer to Figure 1 for installation clearances.

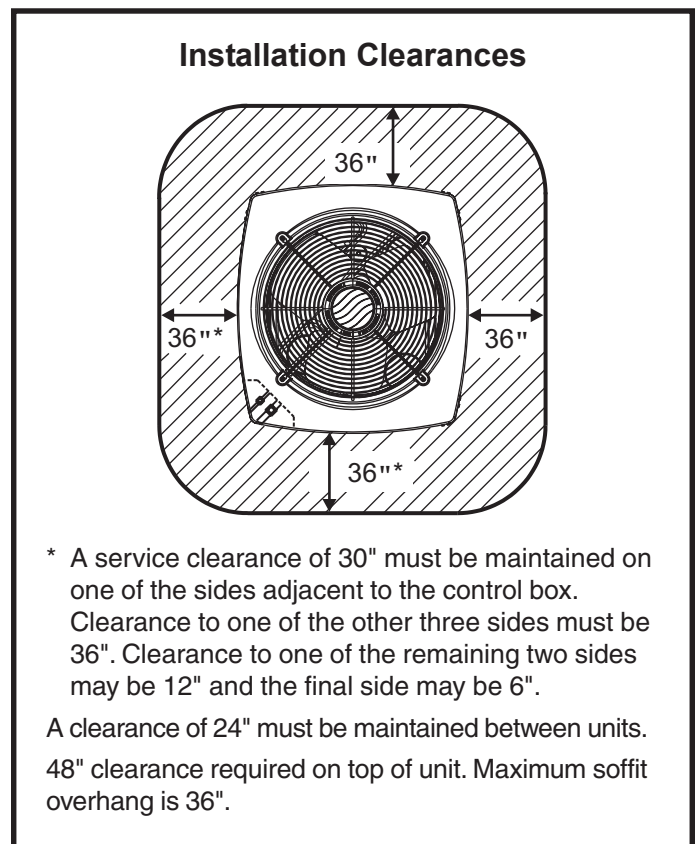

Figure 1

- Place a sound-absorbing material, such as Isomode, under the unit if it will be installed in a location or position that will transmit sound or vibration to the living area or adjacent buildings.
- Install the unit high enough above the ground or roof to allow adequate drainage of defrost water and prevent ice buildup.
- In heavy snow areas, do not locate the unit where drifting snow will occur. The unit base should be elevated above the depth of average snows.

NOTE: Elevation of the unit may be accomplished by constructing a frame using suitable materials. If a support frame is constructed, it must not block drain holes in unit base.

- When installed in areas where low ambient temperatures exist, locate unit so winter prevailing winds do not blow directly into outdoor coil.
- Locate unit away from overhanging roof lines which would allow water or ice to drop on, or in front of, coil or into unit.

Slab Mounting

When installing a unit at grade level, install on level slab high enough above grade so that water from higher ground will not collect around the unit (see Figure 2).

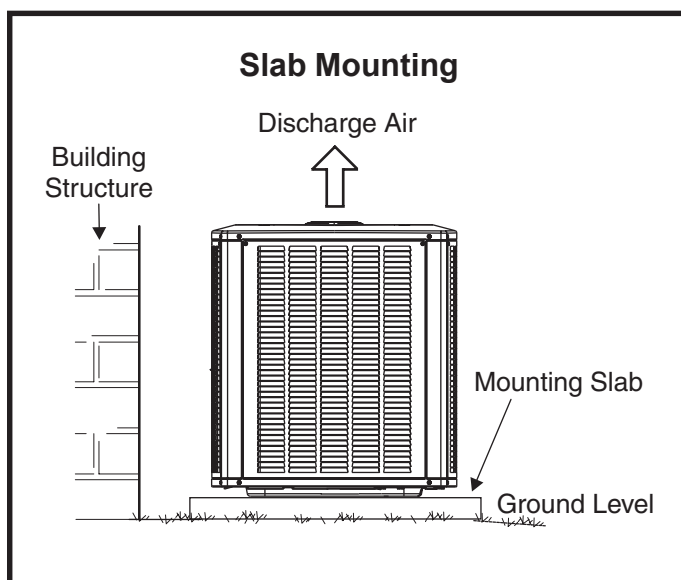

Figure 2

Roof Mounting

Install unit at a minimum of 6" above surface of the roof to avoid ice buildup around the unit. Locate the unit above a load bearing wall or area of the roof that can adequately support the unit. Consult local codes for rooftop applications.

Electrical Wiring

All field wiring must be done in accordance with the National Electrical Code (NEC) recommendations, Canadian Electrical Code (CEC) and CSA Standards, or local codes, where applicable.

⚠ WARNING

Unit must be grounded in accordance with national and local codes. Failure to ground unit properly can result in personal injury or death.

Refer to the furnace or blower coil Installation Instructions for additional wiring application diagrams and refer to unit rating plate for minimum circuit ampacity and maximum overcurrent protection size.

1. Install line voltage power supply to unit from a properly sized disconnect switch. Any excess high voltage field wiring should be trimmed or secured away from the low voltage field wiring.
2. Ground unit at unit disconnect switch or to an earth ground. To facilitate conduit, a hole is in the bottom of the control box. Connect conduit to the control box using a proper conduit fitting. Units are approved for use only with copper conductors. 24V Class II circuit connections are made in the low voltage junction box. A complete unit wiring diagram is located inside the unit control box cover (see also page 26 of this instruction).
3. Install room thermostat on an inside wall that is not subject to drafts, direct sunshine, or other heat sources.
4. Install low voltage wiring from outdoor to indoor unit and from thermostat to indoor unit (see Figure 3 on page 4).
5. Do not bundle any excess 24V control wire inside control box. Run control wire through installed wire tie and tighten wire tie to provide low voltage strain relief and to maintain separation of field-installed low and high voltage circuits.

⚠ WARNING

Line voltage is present at all components when unit is not in operation on units with single pole contactors. Disconnect all remote electric power supplies before opening access panel. Unit may have multiple power supplies. Failure to disconnect all power supplies could result in personal injury or death.

Refrigerant Piping

⚠ WARNING

Refrigerant can be harmful if inhaled. Refrigerant must always be used and recovered responsibly. Incorrect or irresponsible use of refrigerant can result in personal injury or death.

If the 4HP16LT unit is being installed with a new indoor coil and line set, the refrigerant connections should be made as outlined in this section. If an existing line set and/or indoor coil will be used to complete the system, refer to

Thermostat Designations

(Some connections may not apply. Refer to specific thermostat and indoor unit.)

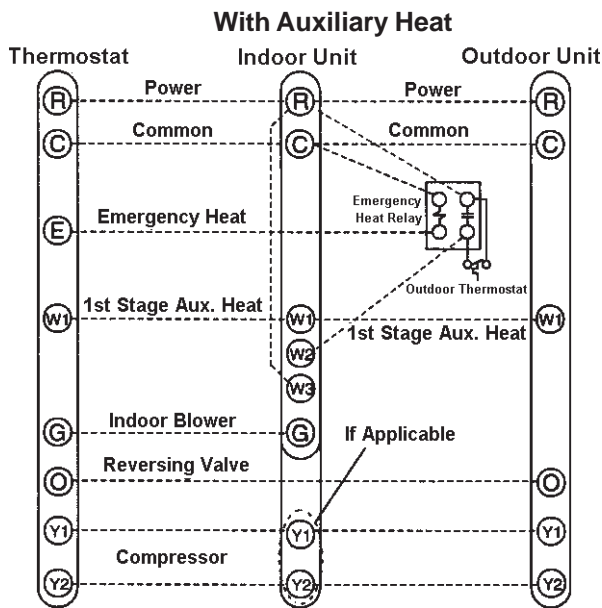
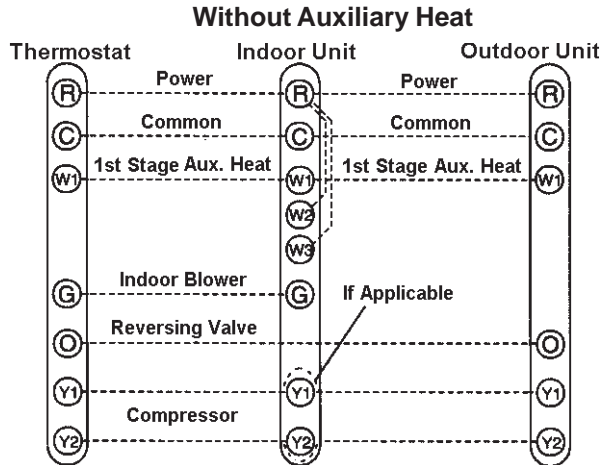

Do not connect C (common) connection between indoor unit and thermostat except when required by the indoor thermostat. Refer to thermostat installation instructions. C (common) connection between indoor unit and outdoor unit required for proper operation.

Figure 3

Field refrigerant piping consists of liquid and suction lines from the outdoor unit (sweat connections) to the indoor coil (flare or sweat connections).

Select line set diameters from Table 2 to ensure that oil returns to the compressor. Size vertical suction riser to maintain minimum velocity at minimum capacity. Recommended line length is 50' or less. If more than 50' line set is required, contact Technical Services.

Table 2 shows the diameters for line sets up to 100' although vertical lift applications and trapping requirements need to be reviewed with Technical Services for line sets over 50'.

Refrigerant Line Set Diameters (in.)

		Liquid Line				
BTUH	Line Set Length and Size					
	12 ft.	25 ft.	50 ft.	75 ft.	100 ft.	
24,000	3/8	3/8	3/8	3/8	3/8	
36,000	3/8	3/8	3/8	3/8	1/2	
48,000	3/8	3/8	3/8	1/2	1/2	
60,000	3/8	3/8	3/8	1/2	1/2	

		Suction Line				
BTUH	Line Set Length and Size					
	12 ft.	25 ft.	50 ft.	75 ft.	100 ft.	
24,000	3/4	7/8	3/4	7/8	7/8	
36,000	7/8	7/8	7/8	7/8	1-1/8	
48,000	7/8	7/8	7/8	1-1/8	1-1/8	
60,000	1-1/8	1-1/8	1-1/8	1-1/8	1-1/8	

For installations exceeding 50', contact Technical Services.

Table 2

this section as well as the section that follows entitled **Flushing Existing Line Set and Indoor Coil.**

If this unit is being matched with an approved line set or indoor coil which was previously charged with R-22 refrigerant, the line set and coil must be flushed prior to installation. If the unit is being used with an existing indoor coil which was equipped with a liquid line which served as a metering device (RFCI), the liquid line must be replaced prior to the installation of the 4HP16LT unit.

WARNING

Polyol ester (POE) oils used with R410A refrigerant absorb moisture very quickly. It is very important that the refrigerant system be kept closed as much as possible. **DO NOT** remove line set caps or service valve stub caps until ready to make connections.

Installing Refrigerant Line

During the installation of an air conditioning system, it is important to properly isolate the refrigerant line to prevent unnecessary vibration. Line set contact with the structure (wall, ceiling, or floor) may cause objectionable noise when vibration is translated into sound. As a result, more energy or vibration can be expected. Close attention to line set isolation must be observed.

Following are some points to consider when placing and installing a high-efficiency outdoor unit:

Placement

Be aware that some localities are adopting sound ordinances based on how noisy the unit is at the neighbor's home, not at the original installation. Install the unit as far as possible from the property line. When possible, do not install the unit directly outside a bedroom window. Glass has a very high level of sound transmission. Figure 4 shows how to place the outdoor unit and line set to reduce line set vibration.

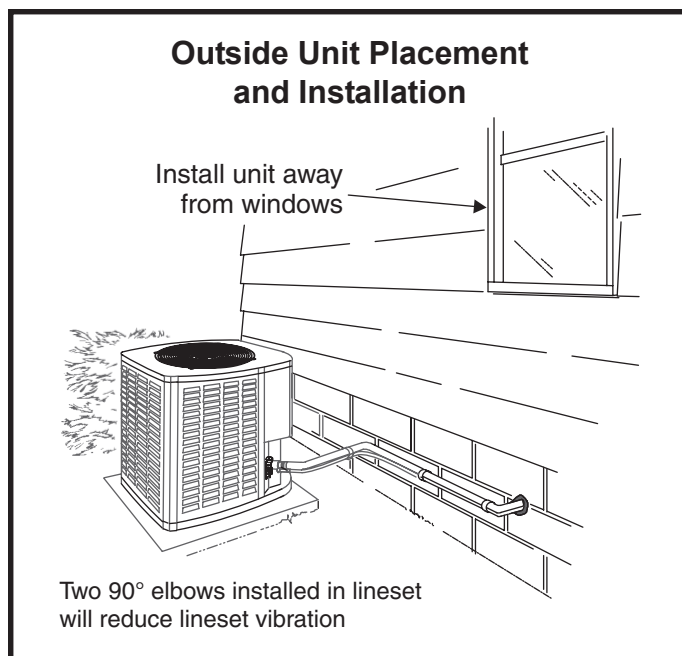

Figure 4

Line Set Isolation

Illustrations on pages 6 and 7 demonstrate procedures which ensure proper refrigerant line set isolation. Figure 5 shows how to install line sets on horizontal runs. Figure 6 shows how to make a transition from horizontal to vertical. Figure 7 shows how to install line sets on vertical runs.

Brazing Connection Procedure

1. Cut ends of refrigerant lines square (free from nicks or dents). Deburr the ends. The pipe must remain round; do not pinch end of line.
2. Before making line set connections, use dry nitrogen to purge the refrigerant piping. This will help to prevent oxidation and the introduction of moisture into the system.
3. Use silver alloy brazing rods (5% or 6% silver alloy for copper-to-copper brazing or 45% silver alloy for copper-to-brass or copper-to-steel brazing) which are rated for use with R410A refrigerant.
4. Remove the Schrader core assemblies before brazing to protect them from damage due to extreme heat. Replace the cores when brazing is complete.
5. Remove light maroon washers from service valves and shield light maroon stickers to protect them during brazing. Wrap a wet cloth around the valve body and copper tube stub to protect it from heat damage.
6. Braze the line set to the service valve. Quench the joints with water or a wet cloth to prevent heat damage to the valve core and opening port. **The tube end must stay bottomed in the fitting during final assembly to ensure proper seating, sealing, and rigidity.**
7. Install a thermal expansion valve (which is sold separately and which is approved for use with R410A refrigerant) in the liquid line at the indoor coil (see **Refrigerant Metering Device** on page 9).

Refrigerant Line Sets: Installing Horizontal Runs

To hang line set from joist or rafter, use either metal strapping material or anchored heavy nylon wire ties.

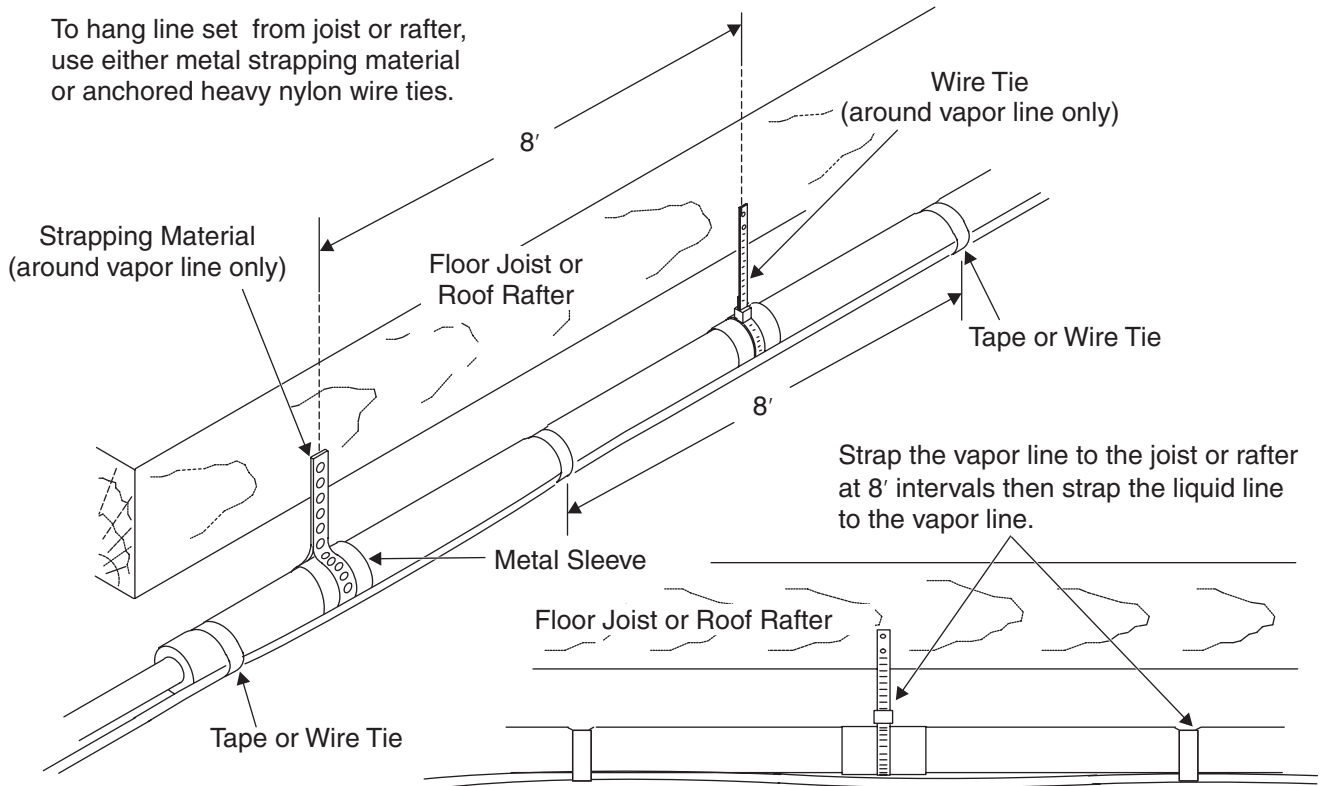

Figure 5

Refrigerant Line Sets: Transition from Vertical to Horizontal

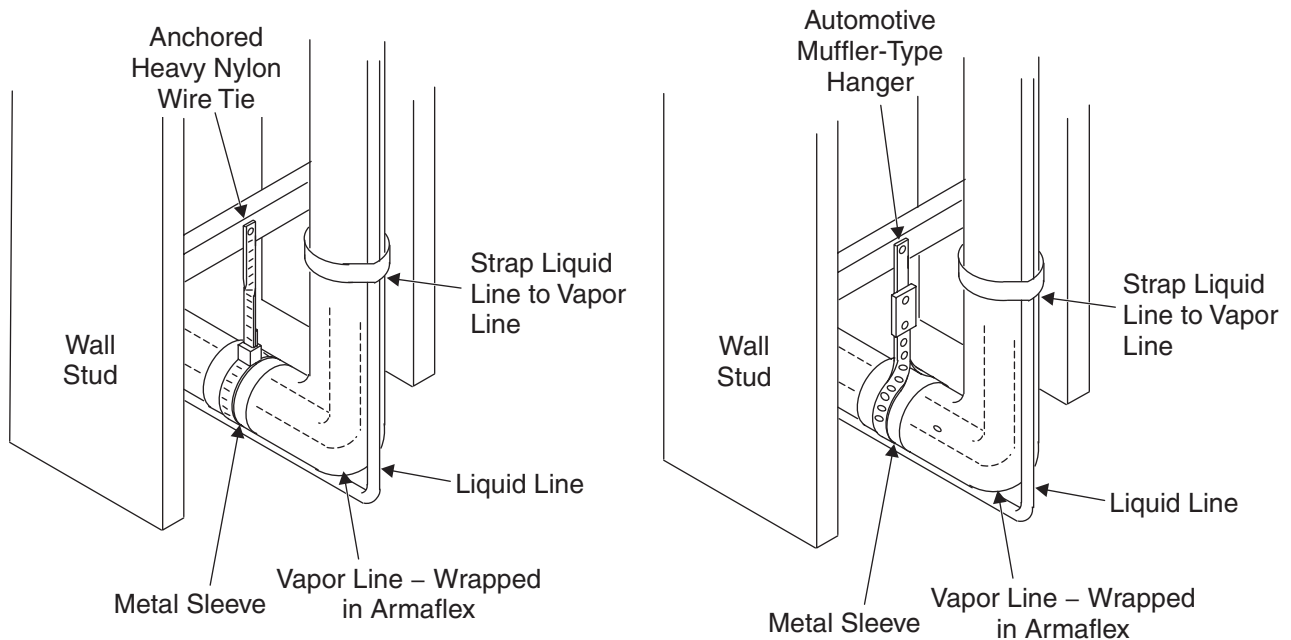

Figure 6

Refrigerant Line Sets: Installing Vertical Runs (new construction shown)

NOTE: Similar installation practices should be used if line set is to be installed on exterior of outside wall.

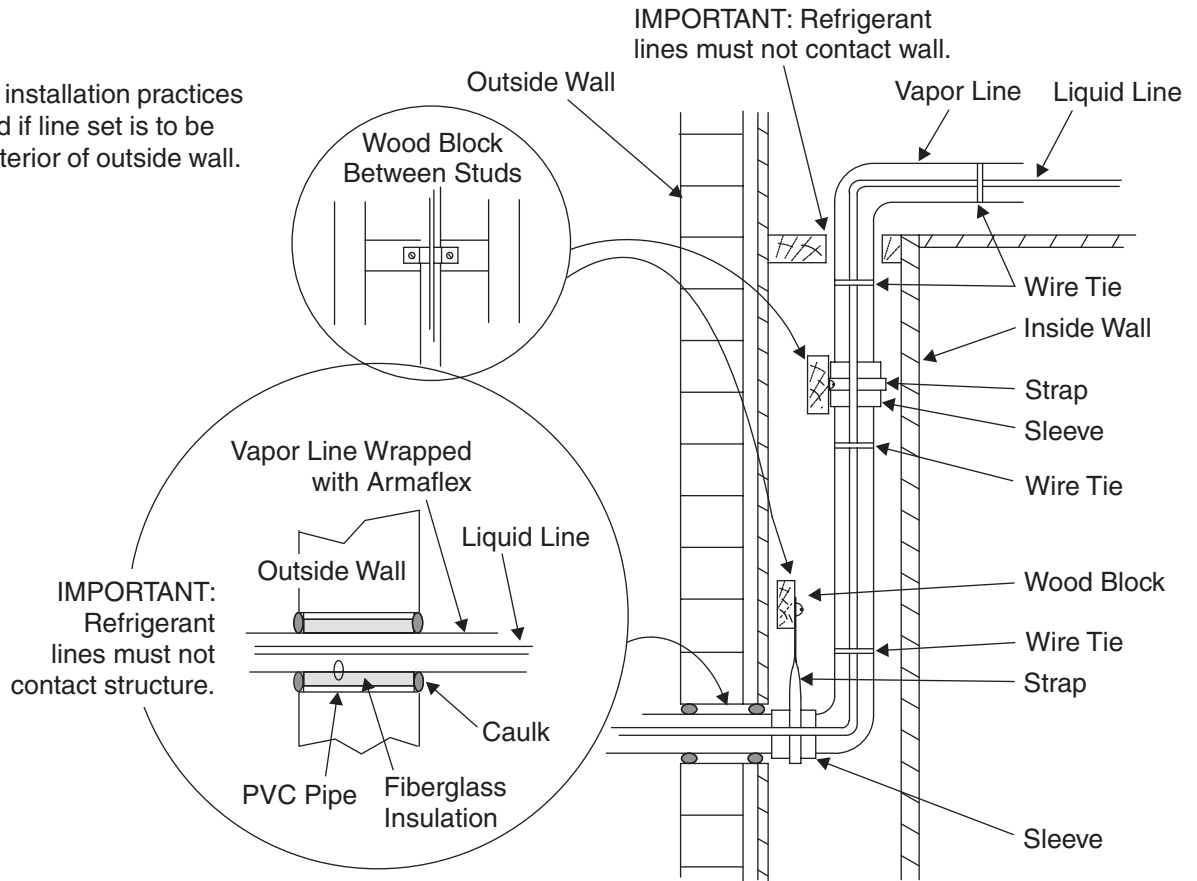

Figure 7

Flushing Existing Line Set and Indoor Coil

This procedure should not be performed on systems which contain contaminants, such as compressor burn out.

CAUTION

When flushing existing line set and/or indoor coil, be sure to empty all existing traps. Residual mineral oil can act as an insulator, preventing proper heat transfer. It can also clog the thermal expansion valve, reducing system performance and capacity. Failure to properly flush system as explained in these instructions will void warranty.

Required Equipment

The following equipment is needed to flush the existing line set and indoor coil (see Figure 8 on page 8): Two clean R22 recovery bottles, an oil-less recovery machine

with a "pump down" feature, and two sets of gauges (one for use with R22 and one for use with R410A).

Flushing Procedure

IMPORTANT: The line set and/or indoor coil must be flushed with at least the same amount of refrigerant that previously charged the system. Check the charge in the flushing cylinder before flushing the unit.

1. Remove existing R22 refrigerant using the appropriate procedure.

If the existing outdoor unit is not equipped with shutoff valves, or if the unit is not operational AND the existing R22 refrigerant will be used to flush the system:

Disconnect all power to the existing outdoor unit. Connect the existing unit, a clean recovery cylinder, and the recovery machine according to the instructions provided with the recovery machine. Remove all R22 refrigerant from the existing system. Refer to the gauges after shutdown to confirm that the entire system is completely void of refrigerant. Disconnect the liquid and suction lines from the existing outdoor unit.

Flushing Connections

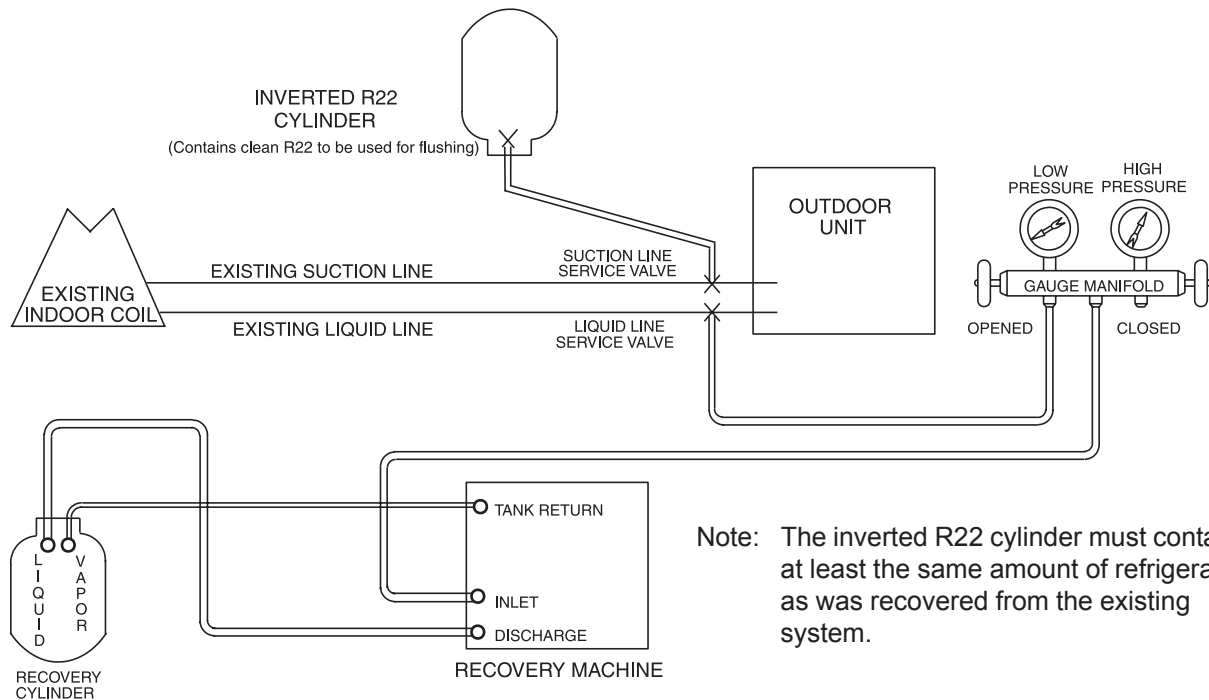

Note: The inverted R22 cylinder must contain at least the same amount of refrigerant as was recovered from the existing system.

Figure 8

If the existing outdoor unit is equipped with manual shutoff valves AND new R22 refrigerant will be used to flush the system:

Start the existing R22 refrigerant system in cooling mode and close the liquid line valve. Pump all the existing R22 refrigerant back into the outdoor unit.

(It may be necessary to bypass the low pressure switches to ensure complete refrigerant evacuation.)

When the low side system pressures reach 0 psig, close the suction line valve. Disconnect all power to the existing outdoor unit. Refer to the gauges after shutdown to confirm that the valves are not allowing refrigerant to flow back into the low side of the system. Disconnect the liquid and suction lines from the existing outdoor unit.

2. Remove the existing outdoor unit. Set the new R410A unit and follow the brazing connection procedure outlined previously on this page to make line set connections. **Do not install the R410A thermal expansion valve at this time.**
3. Make low voltage and line voltage connections to the new outdoor unit. **Do not turn on power to the unit or open the outdoor unit service valves at this time.**
4. Remove the existing R-22 refrigerant flow control orifice or thermal expansion valve before continuing with flushing procedures. R-22 flow control devices

are not approved for use with R410A refrigerant and may prevent proper flushing. Use a field-provided fitting to reconnect the lines.

5. Remove the pressure tap valve cores from the 4HP16LT unit's service valves. Connect an R-22 cylinder with clean refrigerant to the suction service valve. Connect the R-22 gauge set to the liquid line valve and connect a recovery machine with an empty recovery tank to the gauge set.
6. Set the recovery machine for liquid recovery and start the recovery machine. Open the gauge set valves to allow the recovery machine to pull a vacuum on the existing system line set and indoor coil.
7. Invert the cylinder of clean R-22 and open its valve to allow liquid refrigerant to flow into the system through the suction line valve. Allow the refrigerant to pass from the cylinder and through the line set and the indoor coil before it enters the recovery machine.
8. After all of the liquid refrigerant has been recovered, switch the recovery machine to vapor recovery so that all of the R-22 vapor is recovered. Allow the recovery machine to pull a vacuum on the system.

NOTE: A single system flush should remove all of the mineral oil from the existing refrigerant lines and indoor coil. A second flushing may be done (using clean refrigerant) if insufficient amounts of mineral oil were

removed during the first flush. **After each system flush, allow the recovery machine to pull a vacuum on the system at the end of the procedure.**

9. Close the valve on the inverted R22 cylinder and the gauge set valves. Pump the remaining refrigerant out of the recovery machine and turn the machine off.

10. Use nitrogen to break the vacuum on the refrigerant lines and indoor coil before removing the recovery machine, gauges, and R22 refrigerant drum. Re-install pressure tap valve cores into the 4HP16LT unit's service valves.

11. Install a thermal expansion valve approved for use with R410a refrigerant in the liquid line at the indoor coil.

Refrigerant Metering Device

4HP16LT units are designed for use with TXV systems only. An R410a system will not operate properly with an R22 metering device.

Expansion valves equipped with Chatleff-type fittings are available from the manufacturer. See Table 3 for proper TXV for each unit.

TXV Data	
MODEL	PART NUMBER
4HP16LT- 24	H4TXV01
4HP16LT - 36	H4TXV02
4HP16LT - 48, -60	H4TXV03

Table 3

To install an expansion valve (See Figure 9):

1. Separate the distributor assembly and remove the piston orifice and used teflon seal. Insert nozzle end of the expansion valve along with a new teflon seal into the distributor and tighten to 20 - 30 ft. lbs. Use backup wrench on all wrench flats. **Overtightening will crush the teflon seal and may cause a leak.**

2. Attach liquid line portion of distributor assembly along with new teflon seal to the inlet of the expansion valve. Tighten to 20 - 30 ft. lbs. Use backup wrench on all wrench flats. **Overtightening will crush the teflon seal and may cause a leak.**

3. Connect the external equalizer line to the equalizer port on the suction line and tighten to 8 ft.lbs.

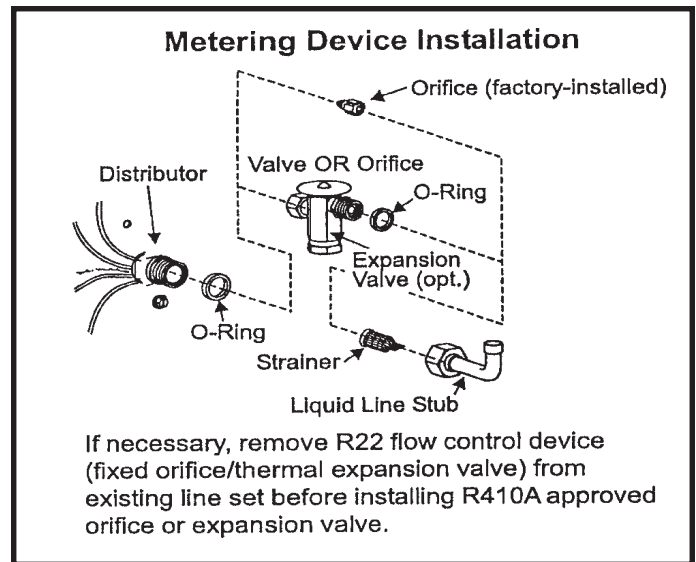

Figure 9

4. Strap the superheat sensing bulb to the suction header.

If installing an expansion valve on an indoor coil that previously used a fixed orifice, be sure to remove the existing fixed orifice. Failure to remove a fixed orifice when installing an expansion valve to the indoor coil will result in improper operation and damage to the system.

Manifold Gauge Set

Manifold gauge sets used with systems charged with R410A refrigerant must be capable of handling the higher system operating pressures. The gauges should be rated for use with pressures 1 - 800 on the high side and a low side of 30" vacuum to 250 psi with dampened speed to 500 psi. Gauge hoses must be rated for use at up to 800 psi of pressure with a 4000 psi burst rating.

Liquid and Suction Line Service Valves

The liquid line and suction line service valves (See Figure 11) and service ports are used for leak testing, evacuation, charging, and checking charge.

Each valve is equipped with a service port which has a factory-installed Schrader valve. A service port cap protects the Schrader valve from contamination and serves as the primary leak seal.

To Access the Schrader Port:

1. Remove the service port cap with an adjustable wrench.
2. Connect gauge to the service port.
3. When testing is completed, replace service port cap. Tighten finger tight, then an additional 1/6 turn.

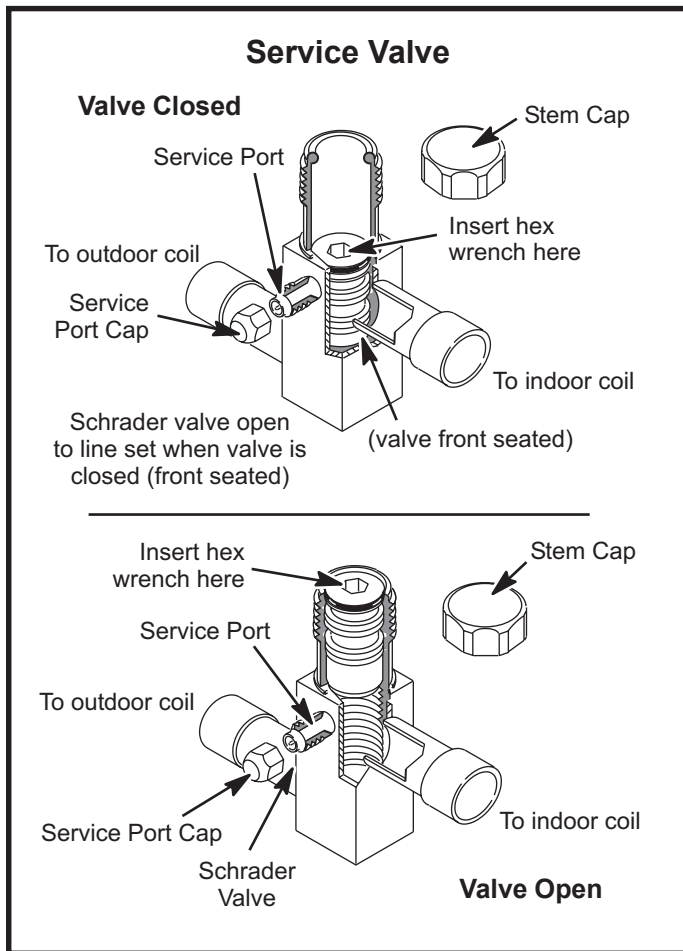

Figure 10

To Open Liquid or Suction Line Service Valve:

1. Remove stem cap with an adjustable wrench.
2. Use a service wrench with a hex-head extension to back the stem out counterclockwise as far as it will go. Use a 3/16" hex head extension for liquid line service valves and a 5/16" extension for suction line service valves.
3. Replace the stem cap. Tighten finger tight, then tighten an additional 1/6 turn.

To Close Liquid or Suction Line Service Valve:

1. Remove the stem cap with an adjustable wrench.
2. Use a service wrench with a hex-head extension to turn the stem clockwise to seat the valve. Tighten firmly.
3. Replace the stem cap. Tighten finger tight, then tighten an additional 1/6 turn.

Suction Line (Ball Type) Service Valve

Suction line (ball type) service valves function the same way as the other valves; the difference is in the construction (see Figure 11).

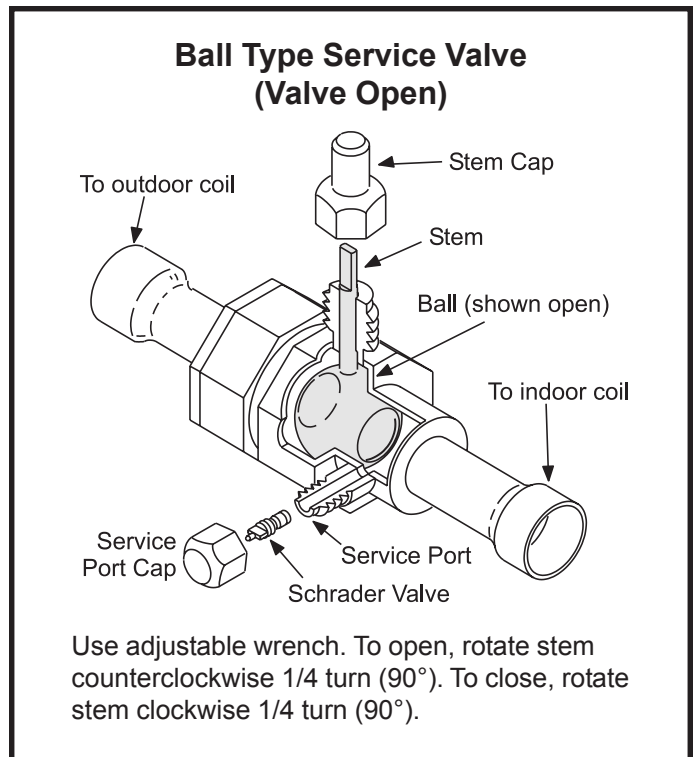

Figure 11

The ball valve is equipped with a service port with a factory-installed Schrader valve. A service port cap protects the Schrader valve from contamination and serves as the primary seal.

Leak Testing

After the line set has been connected to the indoor and outdoor units, the line set connections and indoor unit must be checked for leaks.

⚠ WARNING

Fire, Explosion, and Personal Safety Hazard.

Failure to follow this warning could result in damage, personal injury, or death.

Never use oxygen to pressurize or purge refrigeration lines. Oxygen, when exposed to a spark or open flame, can cause damage by fire and/or an explosion, that could result in personal injury or death.

Using an Electronic Leak Detector

1. Connect the high pressure hose of the manifold gauge set to the suction valve service port. (Normally the high pressure hose is connected to the liquid line port; however, connecting it to the suction ports helps

to protect the manifold gauge set from damage caused by high pressure.)

2. With both manifold valves closed, connect the cylinder of R410A refrigerant. Open the valve on the R410A cylinder (vapor only).
3. Open the high pressure side of the manifold to allow R410A into the line set and indoor unit. Weigh in a trace amount of R410A. (A trace amount is a maximum of 2 oz. of refrigerant or 3 lbs. pressure.) Close the valve on the R410A cylinder and the valve on the high pressure side of the manifold gauge set. Disconnect the R410A cylinder.
4. Connect a cylinder of nitrogen with a pressure regulating valve to the center port of the manifold gauge set.
When using high pressure gas such as nitrogen for this purpose, be sure to use a regulator that can control the pressure down to 1 or 2 psig.
5. Adjust nitrogen pressure to 150 psig. Open the valve on the high side of the manifold gauge set to pressurize the line set and the indoor coil.
6. After a short period of time, open a refrigerant port to make sure that an adequate amount of refrigerant has been added for detection (refrigerant requirements will vary with lengths). Check all joints for leaks. Purge nitrogen and R410A mixture. Correct any leaks and recheck.

Evacuation

Evacuating the system of noncondensables is critical for proper operation of the unit. Noncondensables are defined as any gas that will not condense under temperatures and pressures present during operation of an air conditioning system. Noncondensables and water vapor combine with refrigerant to produce substances that corrode copper piping and compressor parts.

WARNING

Do not use a compressor to evacuate a system. Avoid deep vacuum operation. Extremely low vacuums can cause internal arcing and compressor failure. Danger of equipment damage. Damage caused by deep vacuum operation will void warranty.

Use a thermocouple or thermistor electronic vacuum gauge that is calibrated in microns. Use an instrument that reads down to 50 microns.

1. Connect the manifold gauge set to the service valve ports as follows:

- Low pressure gauge to suction line service valve
- High pressure gauge to liquid line service valve

2. Connect micron gauge.
3. Connect the vacuum pump (with vacuum gauge) to the center port of the manifold gauge set.
4. Open both manifold valves and start vacuum pump.
5. Evacuate the line set and indoor unit to a minimum of 500 microns or lower. During the early stages of evacuation, it is desirable to close the manifold gauge valve at least once to determine if there is a rapid rise in pressure. A rapid rise in pressure indicates a relatively large leak. If this occurs, the leak testing procedure must be repeated.
6. When 500 microns or lower is maintained, close the manifold gauge valves, turn off the vacuum pump, and disconnect the manifold gauge center port hose from the vacuum pump. Attach the manifold gauge center port hose to a nitrogen cylinder with pressure regulator set to 150 psig and purge the hose. Open the manifold gauge valves to break the vacuum in the line set and indoor unit. Close the manifold gauge valves.
7. Shut off the nitrogen cylinder and remove the manifold gauge hose from the cylinder. Open the manifold gauge valves to release the nitrogen from the line set and indoor unit.
8. Reconnect the manifold gauge to the vacuum pump, turn the pump on, and continue to evacuate the line set and indoor unit until 500 microns is maintained within a 20-minute period after shutting off the vacuum pump and closing the manifold gauge valves.
9. When the requirements above have been met, disconnect the manifold hose from the vacuum pump. Open the service valves to break the vacuum in the line set and indoor unit.

START-UP

⚠ CAUTION

If unit is equipped with a crankcase heater, it should be energized 24 hours before unit start-up to prevent compressor damage as a result of slugging.

1. Rotate fan to check for frozen bearings or binding.
2. Inspect all factory and field-installed wiring for loose connections.
3. After evacuation is complete, open liquid line and suction line service valves to release refrigerant charge (contained in outdoor unit) into system.
4. Replace the stem caps and secure finger tight, then tighten an additional 1/6 of a turn.
5. Check voltage supply at the disconnect switch. The voltage must be within the range listed on the unit nameplate. If not, do not start equipment until the power company has been consulted and the voltage condition corrected.
6. Set thermostat for cooling demand, turn on power to indoor blower, and close the outdoor unit disconnect switch to start the unit.
7. Recheck unit voltage with unit running. Power must be within range shown on unit nameplate.

Refrigerant Charging

This system is charged with R410A refrigerant which operates at much higher pressures than R-22. The liquid line drier provided with the unit is approved for use with R410A. Do not replace it with one designed for use with R-22. **This unit is NOT approved for use with coils which use capillary tubes as a refrigerant metering device.**

R410A refrigerant cylinders are rose colored. Refrigerant should be added through the suction valve in the liquid state.

Certain R410A cylinders are identified as being equipped with a dip tube. These allow liquid refrigerant to be drawn from the bottom of the cylinder without inverting the cylinder. Do not turn this type of cylinder upside down to draw refrigerant.

Units are factory charged with the amount of R410A refrigerant indicated on the unit rating plate. This charge is based on a matching indoor coil and outdoor coil with 15' line set. For varying lengths of line set, refer to Table 4 for refrigerant charge adjustment. A blank space is provided on the unit rating plate to list the actual field charge.

Refrigerant Charge Adjustment

Liquid Line Set Diameter	Oz. Per 5 ft. adjust from 15 ft. line set*
3/8 in.	3 oz. Per 5 ft.

* If line length is greater than 15 ft., add this amount.
If line length is less than 15 ft., remove this amount.

Table 4

⚠ IMPORTANT

Mineral oils are not compatible with R410A. If oil must be added, it must be a polyolester oil.

If the system is void of refrigerant, clean the system using the procedure described below.

1. Use dry nitrogen to pressurized the system and check for leaks. Repair leaks, if possible.
2. Evacuate the system to remove as much of the moisture as possible.
3. Use dry nitrogen to break the vacuum.
4. Evacuate the system again.
5. Weigh the appropriate amount of R410A refrigerant (listed on unit nameplate) into the system.
6. Monitor the system to determine the amount of moisture remaining in the oil. Use a test kit to verify that the moisture content is within the kit's dry color range. It may be necessary to replace the filter drier several times to achieve the required dryness level. **If system dryness is not verified, the compressor will fail in the future.**

The outdoor unit should be charged during warm weather. However, applications arise in which charging must occur in the colder months. The method of charging is determined by the unit's **refrigerant metering device** and the **outdoor ambient temperature**.

Measure the liquid line temperature and the outdoor ambient temperature as outlined below:

1. Connect the manifold gauge set to the service valve ports as follows (See Figure 13 above):

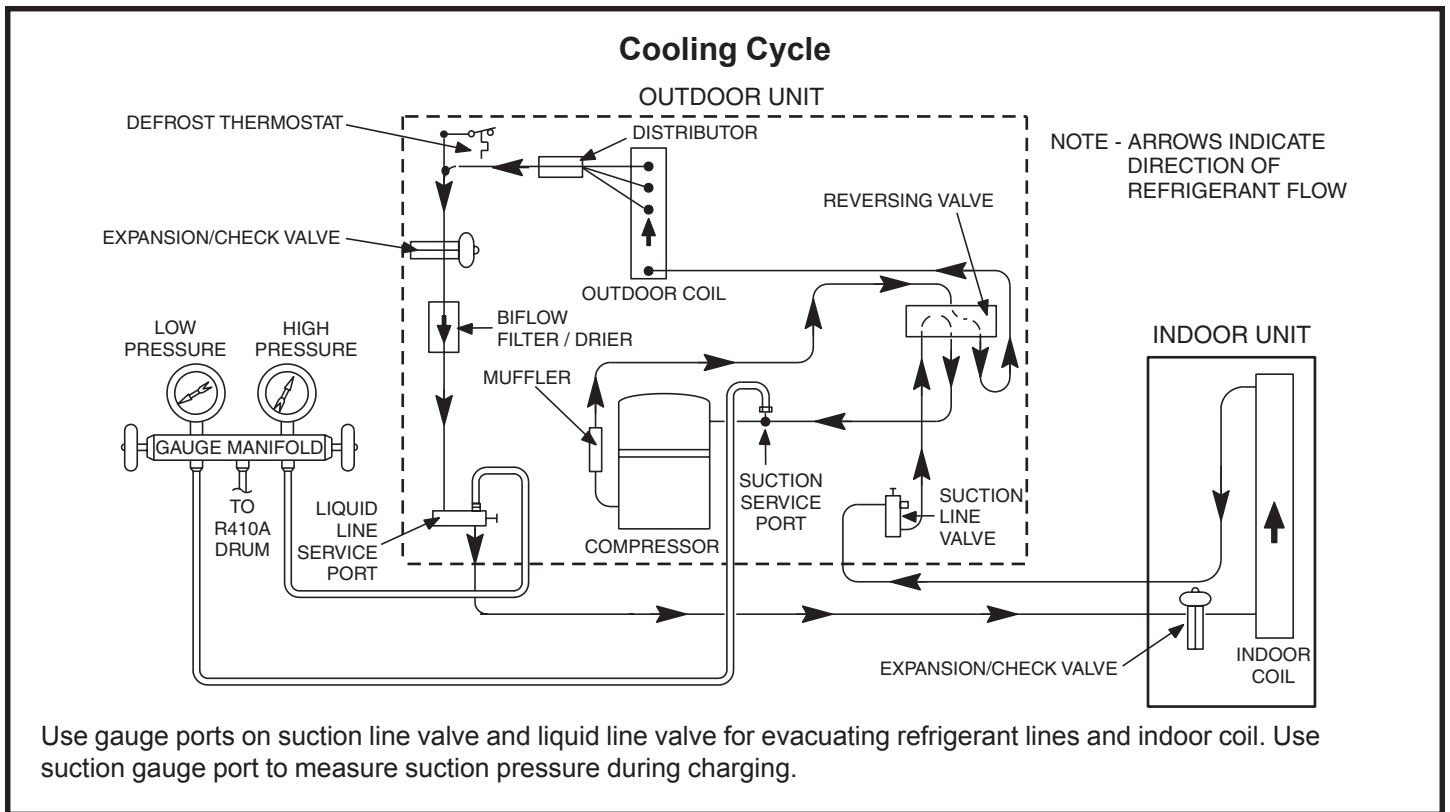

Figure 12

- Low pressure gauge to suction line service valve
 - High pressure gauge to liquid line service valve
2. Close manifold gauge set valves. Connect the center manifold hose to an upright cylinder of R410A.
 3. If room temperature is below 70°F, set the room thermostat to call for heat. This will create the necessary load for properly charging the system in the cooling cycle.
 4. Use a digital thermometer to record the outdoor ambient temperature.
 5. When the heating demand has been satisfied, switch the thermostat to cooling mode with a set point of 68°F. When pressures have stabilized, use a digital thermometer to record the liquid and suction line temperatures.
 6. The outdoor temperature will determine which charging method to use. Proceed with the appropriate charging method.

Charge Using Weigh-In Method

If the system is void of refrigerant, or if the outdoor ambient temperature is cool, first locate and repair any leaks then use the weigh-in method to charge the unit.

1. Recover the refrigerant from the unit.
2. Conduct a leak check, then evacuate as previously outlined.

3. Weigh in the charge according to the total amount shown on the unit nameplate.

If weighing facilities are not available, use one of the following procedures to charge the unit.

Charge Using Subcooling Method – Outdoor Temperatures Below 65°F

When the outdoor ambient temperature is below 65°F, the subcooling method can be used to charge the unit. It may be necessary to restrict the air flow through the outdoor coil to achieve pressures in the 200-250 psig range. These higher pressures are necessary for checking the charge. Block equal sections of air intake panels and move obstructions sideways until the liquid pressure is in the 200-250 psig range (see Figure 13 on page 14).

1. With the manifold gauge hose still on the liquid service port and the unit operating stably, use a digital thermometer to check the liquid line temperature. For best results, use the same digital thermometer to check both the outdoor ambient and the liquid line temperatures.
2. At the same time, record the liquid line pressure reading.
3. Use the temperature/pressure chart (Table 5 on page 14) to determine the saturation temperature for the liquid line pressure reading.

R410A Temperature/Pressure Chart

Temp. °F	Pressure Psig	Temp. °F	Pressure Psig	Temp. °F	Pressure Psig
32	100.8	74	214.0	116	396.0
33	102.9	75	217.4	117	401.3
34	105.0	76	220.9	118	406.7
35	107.1	77	224.4	119	412.2
36	109.2	78	228.0	120	417.7
37	111.4	79	231.6	121	423.2
38	113.6	80	235.3	122	428.8
39	115.8	81	239.0	123	434.5
40	118.0	82	242.7	124	440.2
41	120.3	83	246.5	125	445.9
42	122.6	84	250.3	126	451.8
43	125.0	85	254.1	127	457.6
44	127.3	86	258.0	128	463.5
45	129.7	87	262.0	129	469.5
46	132.2	88	266.0	130	475.6
47	134.6	89	270.0	131	481.6
48	137.1	90	274.1	132	487.8
49	139.6	91	278.2	133	494.0
50	142.2	92	282.3	134	500.2
51	144.8	93	286.5	135	506.5
52	147.4	94	290.3	136	512.9
53	150.1	95	295.1	137	519.3
54	152.8	96	299.4	138	525.8
55	155.5	97	303.8	139	532.4
56	158.2	98	308.2	140	539.0
57	161.0	99	312.7	141	545.6
58	163.9	100	317.2	142	552.3
59	166.7	101	321.8	143	559.1
60	169.6	102	326.4	144	565.9
61	172.6	103	331.0	145	572.8
62	175.5	104	335.7	146	579.8
63	178.5	105	340.5	147	586.8
64	181.6	106	345.3	148	593.8
65	184.3	107	350.1	149	601.0
66	187.7	108	355.0	150	608.1
67	190.9	109	360.0	151	615.4
68	194.1	110	365.0	152	622.7
69	197.3	111	370.0	153	630.1
70	200.6	112	375.1	154	637.5
71	203.9	113	380.2	155	645.0
72	207.2	114	385.4		
73	210.6	115	390.7		
72	207.2	114	385.4		
73	210.6	115	390.7		

Table 5

Blocking Outdoor Coil

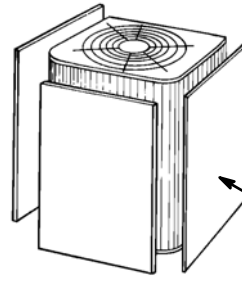

Outdoor coil should be blocked one side at a time with cardboard or plastic sheet until proper testing pressures are reached.

CARDBOARD OR PLASTIC SHEET

Figure 13

4. Subtract the liquid line temperature from the saturation temperature (according to the chart) to determine Subcooling.

$$\begin{aligned} & \text{_____}^\circ \text{ Saturation Temperature } ^\circ\text{F} \\ - & \text{_____}^\circ \text{ Liquid Line Temperature } ^\circ\text{F} \\ = & \text{_____}^\circ \text{ Subcooling Value } ^\circ\text{F} \end{aligned}$$

5. Compare the subcooling value with those shown in Table 6. If subcooling is greater than shown, recover some refrigerant. If subcooling is less than shown, add some refrigerant.

Subcooling Values

Model	-24	-36	-48	-60
Temp. °F	6-7	3-4	11-12	3

Table 6

Charge Using Approach Method (TXV System) - Outdoor Temperatures 65°F or Above

The following procedure is intended as a general guide and is for use on expansion valve systems only. For best results, indoor temperature should be 70°F to 80°F. Monitor system pressures while charging.

1. Record outdoor ambient temperature using a digital thermometer.
2. Attach high pressure gauge set and operate unit for several minutes to allow system pressures to stabilize.
3. Compare stabilized pressures with those provided in Table 7. Minor variations in these pressures may be expected.

Normal Operating Pressures

Heating & Cooling

	24		36		48		60	
	L	S	L	S	L	S	L	S
Cooling (High capacity)								
65	230	130	220	130	230	120	220	130
75	260	135	250	135	260	125	350	135
85	300	138	290	139	300	130	290	139
95	360	140	350	140	360	135	350	140
105	400	145	390	143	410	137	400	145
115	465	150	450	145	470	140	450	150
Heating (High capacity)								
20	330	60	280	65	300	60	300	55
30	355	80	350	85	340	75	320	70
40	400	105	420	105	380	120	350	100
50	450	125	490	125	420	130	390	120

Cooling Indoor: 80 db; 67 wb

Heating (indoor): 70°F

± 2 psi

L - Liquid S- Suction

Values provided above are for HSV match pressures; different indoor unit match, and indoor load will cause pressures to vary.

Table 7

due to differences in installations. **Significant differences could mean that the system is not properly charged or that a problem exists with some component in the system.** Pressures higher than those listed indicate that the system is overcharged. Pressures lower than those listed indicate that the

system is undercharged. Verify adjusted charge using the approach method.

4. Use the same digital thermometer to check liquid line temperature.

5. Subtract the outdoor ambient temperature from the liquid line temperature to determine the approach temperature.

$$\begin{aligned} & \text{_____}^\circ \text{ Liquid Line Temperature }^\circ\text{F} \\ - & \text{_____}^\circ \text{ Outdoor Ambient Temperature }^\circ\text{F} \\ = & \text{_____}^\circ \text{ Approach Temperature }^\circ\text{F} \end{aligned}$$

6. Compare the approach value with those shown in Table 8. If the values do not agree with those provided in Table 8, add refrigerant to lower the approach temperature or recover refrigerant from the system to increase the approach temperature.

Check Charge Using Normal Operating Pressures

Use Table 7 to perform maintenance checks. Table 7 is not a procedure for charging the system. Minor variations in these pressures may be due to differences in installations. Significant deviations could mean that the system is not properly charged or that a problem exists with some component in the system.

Approach Values for TXV Systems				
Model	-24	-36	-48	-60
Temp. °F	7	7	2	8

Approach value is the liquid line temperature minus the outdoor ambient temperature ($\pm 1^\circ\text{F}$).

Note: For best results, use the same digital thermometer to check both outdoor ambient and liquid temperatures.

Table 8

OPERATION

Outdoor unit and indoor blower cycle on demand from the room thermostat. When the thermostat blower switch is moved to the ON position, the indoor blower operates continuously.

Filter Drier

The unit is equipped with a large capacity bi-flow filter which keeps the system clean and dry. If replacement is necessary, replace with one of similar design and capacity. The replacement filter drier must be suitable for use with R410A refrigerant.

Crankcase Heater

If unit is equipped with a crankcase heater, it should be energized 24 hours before unit start-up to prevent compressor damage as a result of slugging.

Emergency Heat Function (Room Thermostat)

An emergency heat function is designed into some room thermostats. This feature is applicable when isolation of outdoor unit is required or when auxiliary electric heat is stage by outdoor thermostats. When the room thermostat is placed in the emergency heat position, the outdoor unit control circuit is isolated from power and the field-supplied relays bypass the outdoor thermostats. An amber indicating light simultaneously comes on to remind the homeowner that the unit is operating in the emergency heat mode.

Emergency heat is usually used during an outdoor shutdown, but it should also be used following a power outage if power has been off for over an hour and the outdoor temperature is below 50°F. System should be left in the emergency heat mode at least 6 hours to allow the crankcase heater sufficient time to prevent compressor slugging.

DEMAND DEFROST SYSTEM DESCRIPTION

The demand defrost controller measures differential temperatures to detect when the system is performing poorly because of ice build-up on the outdoor coil. The controller “self-calibrates” when the defrost system starts and after each system defrost cycle. The defrost control board components are shown below.

The control monitors ambient temperature, outdoor coil temperature, and total run time to determine when a defrost cycle is required. The coil temperature probe is designed with a spring clip to allow mounting to the outside coil tubing. The location of the coil sensor is important for proper defrost operation.

NOTE - The demand defrost board accurately measures the performance of the system as frost accumulates on the outdoor coil. This typically will translate into longer running time between defrost cycles as more frost accumulates on the outdoor coil before the board initiates defrost cycles.

DIAGNOSTIC LEDS

The state (Off, On, Flashing) of two LEDs on the defrost board (DS1 [Red] and DS2 [Green]) indicate diagnostics conditions that are described in table.

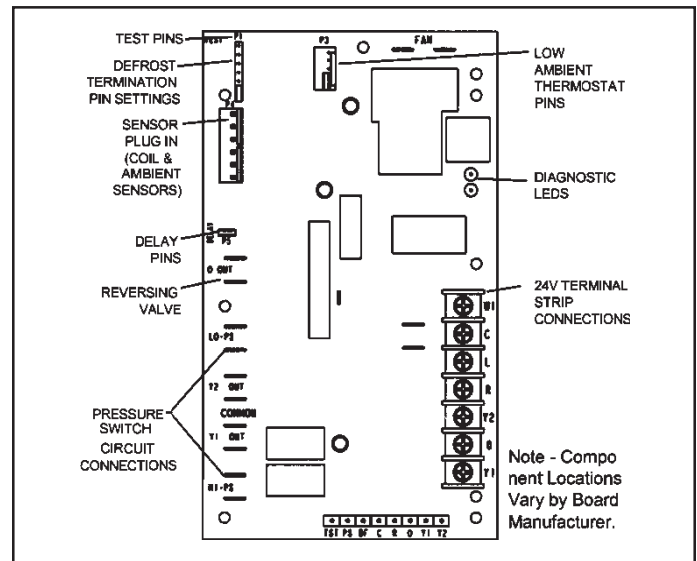

Mode	Green Led (DS2)	Red Led (DS1)
No power to control	OFF	OFF
Normal operation/ power to control	Simultaneous Slow Flash	
Anti-short cycle lockout	Alternating Slow Flash	
Low pressure switch fault (Optional)	OFF	Slow FLASH
Low pressure switch lockout (Optional)	OFF	ON
High pressure switch fault (Optional)	Slow FLASH	OFF
High pressure switch lockout (Optional)	OFF	OFF

DEFROST BOARD PRESSURE SWITCH CONNECTIONS

The unit's automatic reset pressure switches (LO PS - S87 and HI PS - S4) are factory-wired into the defrost board on the LO-PS and HI-PS terminals, respectively.

(OPTIONAL) Low Pressure Switch (LO-PS) — When the low pressure switch trips, the defrost board will cycle off the compressor, and the strike counter in the board will count one strike. The low pressure switch is ignored under the following conditions:

- during the defrost cycle and 90 seconds after the termination of defrost
- when the average ambient sensor temperature is below 15° F (-9°C)
- for 90 seconds following the start up of the compressor
- during “test” mode

High Pressure Switch (HI-PS) — When the high pressure switch trips, the defrost board will cycle off the compressor, and the strike counter in the board will count one strike.

DEFROST BOARD PRESSURE SWITCH SETTINGS

High Pressure (auto reset) - trip at 590 psig; reset at 418.

Low Pressure (auto reset) - trip at 25 psig; reset at 40.

5-STRIKE LOCKOUT FEATURE

The internal control logic of the board counts the pressure switch trips only while the Y1 (Input) line is active. If a pressure switch opens and closes four times during a Y1 (Input), the control logic will reset the pressure switch trip counter to zero at the end of the Y1 (Input). If the pressure switch opens for a fifth time during the current Y1 (Input), the control will enter a lockout condition.

The 5-strike pressure switch lockout condition can be reset by cycling OFF the 24-volt power to the control board or by shorting the TEST pins between 1 and 2 seconds. All timer functions (run times) will also be reset.

If a pressure switch opens while the Y1 Out line is engaged, a 5-minute short cycle will occur after the switch closes.

DEFROST SYSTEM SENSORS

Sensors connect to the defrost board through a field-replaceable harness assembly that plugs into the board. Through the sensors, the board detects outdoor ambient, coil, and discharge temperature fault conditions. As the detected temperature changes, the resistance across the sensor changes. Sensor resistance values can be checked by ohming across pins .

Sensor Temp. / Resistance Range

Sensor	Temperature Range °F (°C)	Red Led (DS1)	Pins/Wire Color
Outdoor (Ambient)	-35 (-37 to 120 (48)	280,000 to 3750	3 & 4 (Black)
Coil	-35 (-37) to 120 (48)	280,000 to 3750	5 & 6 (Brown)
Discharge (If applicable)	24 (-4) to 350 (176)	41,000 to 103	1 & 2 (Yellow)

Note: Sensor resistance decreases as sensed temperature increases.

NOTE - When checking the ohms across a sensor, be aware that a sensor showing a resistance value that is not within the range shown, may be performing as designed. However, if a shorted or open circuit is detected, then the sensor may be faulty and the sensor harness will need to be replaced.

Coil Sensor—The coil temperature sensor considers outdoor temperatures below -35°F (-37°C) or above 120°F (48°C) as a fault. If the coil temperature sensor is detected as being open, shorted or out of the temperature range of the sensor, the board will not perform demand or time/temperature defrost operation and will display the appropriate fault code. Heating and cooling operation will be allowed in this fault condition.

Ambient Sensor—The ambient sensor considers outdoor temperatures below -35°F (-37°C) or above 120°F (48°C) as a fault. If the ambient sensor is detected as being open, shorted or out of the temperature range of the sensor, the board will not perform demand defrost operation. The board will revert to time/temperature defrost operation and will display the appropriate fault code. Heating and cooling operation will be allowed in this fault condition.

NOTE - Within a single room thermostat demand, if 5-strikes occur, the board will lockout the unit. Defrost board 24 volt power “R” must be cycled “OFF” or the “TEST” pins on board must be shorted between 1 to 2 seconds to reset the board.

Defrost Temperature Termination Shunt (Jumper)

Pins—The defrost board selections are: 50, 70, 90, and 100°F (10, 21, 32 and 38°C). The shunt termination pin is factory set at 50°F (10°C). If the temperature shunt is not installed, the default termination temperature is 90°F (32°C).

DELAY MODE

The defrost board has a field-selectable function to reduce occasional sounds that may occur while the unit is cycling in and out of the defrost mode. When a jumper is installed on the DELAY pins, the compressor will be cycled off for 30 seconds going in and out of the defrost mode. Units are shipped with jumper installed on DELAY pins.

NOTE - The 30 second off cycle is NOT functional when jumpering the TEST pins.

OPERATIONAL DESCRIPTION

The defrost control board has three basic operational modes: normal, calibration, and defrost.

Normal Mode—The demand defrost board monitors the O line, to determine the system operating mode (heat/cool), outdoor ambient temperature, coil temperature (outdoor coil) and compressor run time to determine when a defrost cycle is required.

Calibration Mode—The board is considered uncalibrated when power is applied to the board, after cool mode operation, or if the coil temperature exceeds the termination temperature when it is in heat mode.

Calibration of the board occurs after a defrost cycle to ensure that there is no ice on the coil. During calibration, the temperature of both the coil and the ambient sensor are measured to establish the temperature differential which is required to allow a defrost cycle.

Defrost Mode—The following paragraphs provide a detailed description of the defrost system operation.

DETAILED DEFROST SYSTEM OPERATION

Defrost Cycles—The demand defrost control board initiates a defrost cycle based on either frost detection or time.

- **Frost Detection**—If the compressor runs longer than 30 minutes and the actual difference between the clear coil and frosted coil temperatures exceeds the maximum difference allowed by the control, a defrost cycle will be initiated.

IMPORTANT - The demand defrost control board will allow a greater accumulation of frost and will initiate fewer defrost cycles than a time/temperature defrost system.

- **Time**—If 6 hours of heating mode compressor run time has elapsed since the last defrost cycle while the coil temperature remains below 35°F (2°C), the demand defrost control will initiate a defrost cycle.

Actuation—When the reversing valve is de-energized, the Y1 circuit is energized, and the coil temperature is below 35°F (2°C), the board logs the compressor run time. If the board is not calibrated, a defrost cycle will be initiated after 30 minutes of heating mode compressor run time. The control will attempt to self-calibrate after this (and all other) defrost cycle(s).

Calibration success depends on stable system temperatures during the 20-minute calibration period. If the board fails to calibrate, another defrost cycle will be initiated after 45 minutes of heating mode compressor run time. Once the defrost board is calibrated, it initiates a demand defrost cycle when the difference between the clear coil and frosted coil temperatures exceeds the maximum difference allowed by the control OR after 6 hours of heating mode compressor run time has been logged since the last defrost cycle.

NOTE - If ambient or coil fault is detected, the board will not execute the "TEST" mode.

Termination—The defrost cycle ends when the coil temperature exceeds the termination temperature or after 14 minutes of defrost operation. If the defrost is terminated by the 14-minute timer, another defrost cycle will be initiated after 30 minutes of run time.

Test Mode—When Y1 is energized and 24V power is being applied to the board, a test cycle can be initiated by placing the termination temperature jumper across the "Test" pins for 2 to 5 seconds. If the jumper remains across the "Test" pins longer than 5 seconds, the control will ignore the test pins and revert to normal operation. The jumper will initiate one cycle per test.

Enter the "TEST" mode by placing a shunt (jumper) across the "TEST" pins on the board **after** power-up. (The "TEST" pins are ignored and the test function is locked out if the shunt is applied on the "TEST" pins before power-up). Board timings are reduced, the low-pressure switch is ignored and the board will clear any active lockout condition.

Each test pin shorting will result in one test event. For each "TEST" the shunt (jumper) must be removed for at least 1 second and reapplied. Refer to flow chart for "TEST" operation.

Note: The Y1 input must be active (ON) and the "O" room thermostat terminal into board must be inactive.

DEFROST BOARD DIAGNOSTICS

See defrost control board diagnostic LED table on next page to determine defrost board operational conditions and to diagnose cause and solution to problems.

TEST

Placing the jumper on the test pins allows the technician to:

- Clear short cycle lockout
- Clear five-strike fault lockout
- Cycle the unit in and out of defrost mode
- Place the unit in defrost mode to clear the coil

When Y1 is energized and 24V power is being applied to the Demand Defrost Control, a test cycle can be initiated by placing a jumper on the Demand Defrost Control's TEST pins for 2 to 5 seconds. If the jumper remains on the TEST pins for longer than five seconds, the Demand Defrost Control will ignore the jumpered TEST pins and revert to normal operation.

The control will initiate one test event each time a jumper is placed on the TEST pins. For each TEST the jumper must be removed for at least one second and then reapplied.

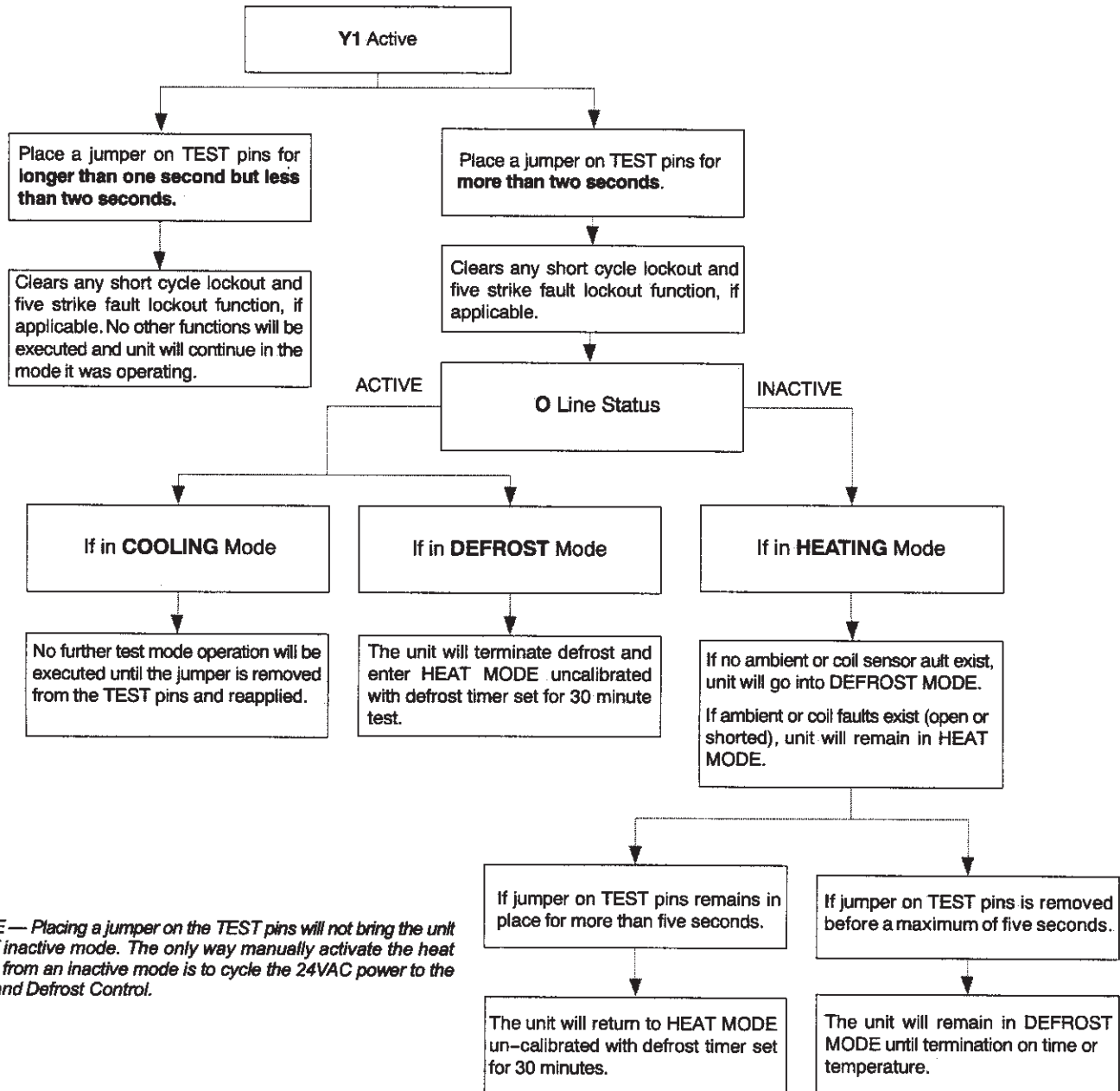
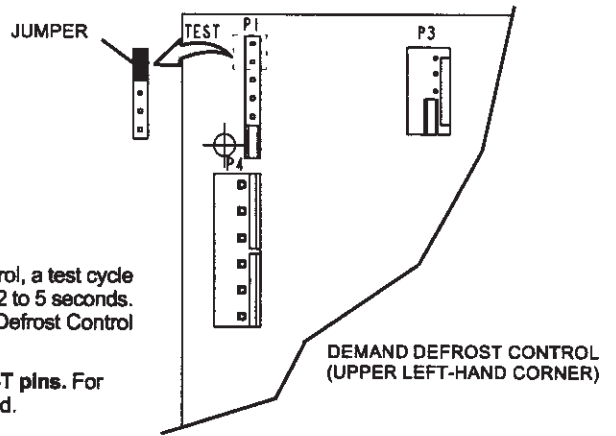

NOTE — Placing a jumper on the TEST pins will not bring the unit out of inactive mode. The only way manually activate the heat pump from an inactive mode is to cycle the 24VAC power to the Demand Defrost Control.

Defrost Control Board Diagnostic LEDs

DS2 Green	DS1 Red	Condition/Code	Possible Cause(s)	Solution
OFF	OFF	Power problem	No power (24V) to board terminals R & C or board failure.	<ol style="list-style-type: none"> 1 Check control transformer power (24V). 2 If power is available to board and LED(s) do not light, replace board.
Simultaneous SLOW Flash		Normal operation	Unit operating normally or in standby mode.	None required.
Alternating SLOW Flash		5-minute anti-short cycle delay	Initial power up, safety trip, end of room thermostat demand.	None required (Jumper TEST pins to override)
Simultaneous FAST Flash		Ambient Sensor Problem	Sensor being detected open or shorted or out of temperature range. Board will revert to time/temperature defrost operation. (System will still heat or cool).	
Alternating FAST Flash		Coil Sensor Problem	Sensor being detected open or shorted or out of temperature range. Board will not perform demand or time/temperature defrost operation. (System will still heat or cool).	
ON	ON	Circuit Board Failure	Indicates that board has internal component failure. Cycle 24 volt power to board. If code does not clear, replace board.	

FAULT & LOCKOUT CODES (Each fault adds 1 strike to that code's counter; 5 strikes per code = LOCKOUT)

OFF	SLOW Flash	Low Pressure Fault	<ol style="list-style-type: none"> 1 Restricted air flow over indoor or outdoor coil. 2 Improper refrigerant charge in system. 3 Improper metering device installed or incorrect operation of metering device. 4 Incorrect or improper sensor location or connection to system. 	<ol style="list-style-type: none"> 1 Remove any blockages or restrictions from coils and/or fans. Check indoor and outdoor fan motor for proper current draws. 2 Check system charge using approach & sub-cooling temperatures. 3 Check system operating pressures and compare to unit charging charts. 4 Make sure all pressure switches and sensors have secure connections to system to prevent refrigerant leaks or errors in pressure and temperature measurements.
OFF	ON	Low Pressure LOCKOUT		
SLOW Flash	OFF	High Pressure Fault		
ON	OFF	High Pressure LOCKOUT		
SLOW Flash	ON	Discharge Line Temperature Fault	This code detects shorted sensor or high discharge temperatures. If the discharge line temperature exceeds a temperature of 300°F (148°C) during compressor operation, the board will de-energize the compressor contactor output (and the defrost output if active). The compressor will remain off until the discharge temperature has dropped below 225°F (107°C).	
FAST Flash	ON	Discharge Line Temperature LOCKOUT		
OFF	Fast Flash	Discharge Sensor Fault	The board detects open sensor or out of temperature sensor range. This fault is detected by allowing the unit to run for 90 seconds before checking sensor resistance. If the sensor resistance is not within range after 90 seconds, the board will count one fault. After 5 faults, the board will lockout.	
Fast Flash	OFF	Discharge Sensor LOCKOUT		

System Diagnostic Module

4HP16LT units contain a diagnostic module for troubleshooting heat pump system failures. By monitoring and analyzing data from the compressor and thermostat demand, the module can accurately detect the cause of electrical and system related failure without any sensors. If a system problem occurs, a flashing LED indicator communicates the failure code.

LED Description

POWER LED (Green) indicates voltage is present at the power connection of the module.

ALERT LED (Yellow) communicates an abnormal system condition through a unique flash code. The ALERT LED will flash a number of times consecutively, pause, and then repeat the process. The number of consecutive

flashes correlates to a particular abnormal condition. **TRIP LED (Red)** indicates there is a demand signal from the thermostat but no current to the compressor is detected by the module. The TRIP LED typically indicates the compressor protector is open or may indicate missing supply power to the compressor.

Interpreting the Diagnostic LEDs

When an abnormal system condition occurs, the diagnostic module displays the appropriate ALERT and/or TRIP LED. The yellow ALERT LED will flash a number of times consecutively, pause, and then repeat the process. To identify a flash code number, count the number of consecutive flashes. Refer to Table 10 below and Table 11 on page 20 for information on the flash codes.

Every time the module powers up, the last ALERT LED flash code that occurred prior to shutdown is displayed for

Flash Codes		
LED Status	Fault Description	Troubleshooting Information
POWER (Green)	Module has power	Supply voltage is present at module terminals
TRIP (Red)	Thermostat demand signal Y1 is present, but the compressor is not running	<ol style="list-style-type: none"> Compressor protector is open <ul style="list-style-type: none"> * Check for high head pressure * Check compressor supply voltage Outdoor unit power disconnect is open Compressor circuit breaker or fuse(s) is open Broken wire or connector is not making contact Low pressure switch open if present in system Compressor contactor has failed open
ALERT (Yellow) Flash Code 1	<p>Long Run Time Compressor is running extremely long run cycles</p> <p>(Not applicable on heat pump models)</p>	--
ALERT (Yellow) Flash Code 2	<p>System Pressure Trip Discharge or suction pressure out of limits or compressor overloaded</p>	<ol style="list-style-type: none"> High head pressure <ul style="list-style-type: none"> * Check high pressure switch if present in system * Check if system is overcharged with refrigerant * Check for non-condensable in system Condenser coil poor air circulation (dirty, blocked, damaged) Condenser fan is not running <ul style="list-style-type: none"> * Check fan capacitor * Check fan wiring and connectors * Check fan motor for failure or blockage Return air duct has substantial leakage If low pressure switch present in system, check Flash Code 1 info

Table 10

60 seconds. The module will continue to display the previous flash code until the condition returns to normal or 24VAC is removed from the module. TRIP and ALERT LEDs flashing at the same time means control circuit voltage is too low for operation.

24VAC Power Wiring

The diagnostic module requires a constant nominal 24VAC power supply. The wiring to the module's R and C terminals must be directly from the indoor unit or thermostat. The module cannot be powered by R and C terminals on the defrost board without experiencing nuisance alerts.

Flash Codes (cont.)

LED Status	Fault Description	Troubleshooting Information
ALERT (Yellow) Flash Code 3	Short Cycling Compressor is running only briefly	<ol style="list-style-type: none"> 1. Thermostat demand signal is intermittent 2. Time delay relay or control board defective 3. If high pressure switch present, go to Flash Code 2 info 4. If low pressure switch present, go to Flash Code 1 info
ALERT (Yellow) Flash Code 4	Locked Rotor	<ol style="list-style-type: none"> 1. Run capacitor has failed 2. Low line voltage (contact utility if voltage at disconnect is low) * Check wiring connections 3. Excessive liquid refrigerant in compressor 4. Compressor bearings are seized *Measure compressor oil level
ALERT (Yellow) Flash Code 5	Open Circuit	<ol style="list-style-type: none"> 1. Outdoor unit power disconnect is open 2. Compressor circuit breaker or fuse(s) is open 3. Compressor contactor has failed open * Check compressor contactor wiring and connectors * Check for compressor contactor failure (burned, pitted, or open) * Check wiring and connectors between supply and compressor * Check for low pilot voltage at compressor contactor coil 4. High pressure switch is open and requires manual reset 5. Open circuit in compressor supply wiring or connections 6. Unusually long compressor protector reset time due to extreme ambient temperature 7. Compressor windings are damaged * Check compressor motor winding resistance
ALERT (Yellow) Flash Code 6	Open Start Circuit Current only in run circuit	<ol style="list-style-type: none"> 1. Run capacitor has failed 2. Open circuit in compressor start wiring or connections * Check wiring and connectors between supply and the compressor S terminal 3. Compressor start winding is damaged * Check compressor motor winding resistance
ALERT (Yellow) Flash Code 7	Open Run Circuit Current only in start circuit	<ol style="list-style-type: none"> 1. Open circuit in compressor run wiring or connections * Check wiring and connectors between supply and the compressor R terminal 2. Compressor run winding is damaged * Check compressor motor winding resistance
ALERT (Yellow) Flash Code 8	Welded Contactor Compressor always runs	<ol style="list-style-type: none"> 1. Compressor contactor has failed closed 2. Thermostat demand signal not connected to module
ALERT (Yellow) Flash Code 9	Low Voltage Control circuit less than 17VAC	<ol style="list-style-type: none"> 1. Control circuit transformer is overloaded 2. Low line voltage (contact utility if voltage at disconnect is low) * Check wiring conditions

Table 11

Thermostat Demand Wiring

The diagnostic module requires a thermostat demand signal to operate properly. The thermostat demand signal input, labeled Y on the module, should always be connected to the compressor contactor coil so that when the coil is energized, the demand signal input is 24VAC. When the coil is not energized, the demand signal input should be less than 0.5VAC.

Miswired Module Codes

Depending on the system configuration, some ALERT flash codes may not be active. The presence of safety switches affects how the system alerts are displayed by the module.

Miswiring the diagnostic module will cause false LED codes. Table 12 describes LED operation when the module is miswired and what troubleshooting action is required to correct the problem.

Miswired Module Troubleshooting	
Miswired Module Indication	Recommended Troubleshooting Action
Green LED is not on, module does not power up.	Determine if both R and C module terminals are connected. Verify voltage is present at module's R and C terminals. Review 24VAC Power Wiring section on page 20 for R and C wiring.
Green LED intermittent, module powers up only when compressor runs.	Determine if R and Y terminals are wired in reverse. Verify module's R and C terminals have a constant source. Review 24VAC Power Wiring section on page 20 for R and C wiring.
TRIP LED is on but system and compressor check OK.	Verify Y terminal is connected to 24VAC at contactor coil. Verify voltage at contactor coils falls below 0.5VAC when off.
TRIP LED and ALERT LED flashing together.	Verify R and C terminals are supplied with 19-28VAC.
ALERT Flash Code 3 (Compressor Short Cycling) displayed incorrectly.	Verify Y terminal is connected to 24VAC at contactor coil. Verify voltage at contactor coil falls below 0.5VAC when off.
ALERT Flash Code 5, 6, or 7 (Open Circuit, Open Start Circuit, or Open Run Circuit) displayed incorrectly.	Check that compressor run and start wires are through module's current sensing holes. Verify Y terminal is connected to 24VAC at contactor coil. Verify voltage at contactor coil falls below 0.5VAC when off.
ALERT Flash Code 6 (Open Start Circuit) displayed for Code 7 (Open Run Circuit) or vice versa.	Check that compressor run and start wires are routed through the correct module sensing holes.
ALERT Flash Code 8 (Welded Contactor) displayed incorrectly.	Determine if module's Y terminal is connected. Verify Y terminal is connected to 24VAC at contactor coil. Verify 24VAC is present across Y and C when thermostat demand signal is present. If not, R and C are reverse wired. Verify voltage at contactor coil falls below 0.5VAC when off. Review Thermostat Demand Wiring on this page for Y and C wiring.

Table 12

MAINTENANCE

WARNING

Before performing maintenance operations on system, turn the electric power to unit OFF at disconnect switch(es). Unit may have multiple power supplies. Electrical shock could cause personal injury or death.

Before the start of each heating and cooling season, the following service checks should be performed by a qualified service technician.

- Inspect and clean outdoor and indoor coils. The outdoor coil may be flushed with a water hose.

NOTE: It may be necessary to flush the outdoor coil more frequently if it is exposed to substances which are corrosive or which block airflow across the coil (such as pet urine, cottonwood seeds, etc...).
- Visually inspect the refrigerant lines and coils for leaks.
- Check wiring for loose connections.
- Check voltage at the indoor and outdoor units (with units operating).
- Check amperage draw at the outdoor fan motor, compressor, and indoor blower motor. Values should be compared with those given on unit nameplate.
- Check, clean (or replace) indoor unit filters.
- Check the refrigerant charge and gauge the system pressures.
- Check the condensate drain line for free and unobstructed flow. Clean drain line, if necessary.
- Adjust blower speed for cooling. Measure the pressure drop over the coil to determine the correct blower CFM.
- Belt drive blowers: Check drive belt for wear and proper tensions.

If insufficient cooling is reported, the unit should be gauged and refrigerant charge checked (see **Refrigerant Charging** on page 12).

HOMEOWNER INFORMATION

In order to ensure peak performance, your system must be properly maintained. Clogged filters and blocked airflow prevent your unit from operating at its most efficient level.

⚠ WARNING

Turn all electric power to unit OFF at disconnect switch(es) before performing any maintenance operations on system. Unit may have multiple power supplies. Electrical shock could cause personal injury or death.

- Ask your dealer to show you where the indoor unit's filter is located. It will be either at the indoor unit (installed internal or external to the cabinet) or behind a return air grille in the wall or ceiling. Check the filter monthly and clean or replace it as needed.
- Disposable filters should be replaced with a filter of the same type and size. If you are unsure of the filter you need for your system, contact your dealer.
- Many indoor units are equipped with reusable foam filters. These filters can be cleaned with a mild soap and water solution. Rinse the filter thoroughly and let dry completely before returning to unit or grille.

The filter and all access panels must be in place any time the unit is in operation.

- Some systems are equipped with an electronic air cleaner, designed to remove the majority of airborne particles from the air passing through the cleaner. If your system includes an electronic air cleaner, ask your dealer for maintenance instructions.
- Inspect and clean indoor coil. The indoor evaporator coil is equipped with a drain pan to collect condensate formed as the system removes humidity from the inside air. Have your dealer show you the location of the drain line and how to check for obstructions. This also applies to an auxiliary drain, if one is installed.
- Inspect and clean outdoor coil:

Make sure no obstructions restrict airflow to the outdoor unit. Leaves, trash, or shrubs crowding the unit can cause it to work harder and use more energy. Keep shrubbery trimmed away from the unit and periodically check for debris which collects around the unit.

The outdoor coil may require frequent cleaning, depending on environmental conditions. Clean the outdoor coil with an unpressurized water hose to remove surface contaminants and debris. It may be necessary to flush the outdoor coil more frequently if it

is exposed to substances which are corrosive or which block airflow across the coil (such as pet urine, cottonwood seeds, etc...).

Heat Pump Operation

Heat pump units have several characteristics you should be aware of:

- Heat pumps satisfy heating demand by delivering large amounts of *warm* air into the living space. This is quite different from gas-fired, oil-fired, or electric furnaces which deliver lower volumes of considerably *hotter* air to heat the space.
- Do not be alarmed if you notice frost on the outdoor coil in the winter months. Frost develops on the outdoor coil during the heating cycle when temperatures are below 45°F. An electronic control activates a defrost cycle lasting 5 to 15 minutes at preset intervals to clear the outdoor coil of the frost. A shift in sound type does occur during the defrost mode.
- During the defrost cycle, you may notice steam rising from the unit. This is a normal occurrence. The thermostat may engage auxiliary heat during the defrost cycle to satisfy a heating demand. The unit will return to normal operation at the conclusion of the defrost cycle.

In case of extended power outage...

If the outdoor temperature is below 50°F and power to the outdoor unit has been interrupted for 6 hours or longer, observe the following when restoring power to the heat pump system.

- Set the room thermostat selector to the "Emergency Heat" setting to obtain temporary heat for a minimum of 6 hours. This will allow system refrigerant pressures and temperatures enough time to return to a stabilized condition.
- In the Emergency Heat mode, all heating demand is satisfied by auxiliary heat; heat pump operation is locked out. After a 6-hour "warmup" period, the thermostat can then be switched to the "Heat" setting and normal heat operation may resume.

Thermostat Operation

Though your thermostat may vary somewhat from the description below, its operation will be similar.

Temperature Setting Levers

Most heat pump thermostats have two temperature selector levers: one for heating and one for cooling. Set the levers or dials to the desired temperature setpoints for both heating and cooling. Avoid frequent temperature

adjustment; turning the unit off and back on before pressures equalize puts stress on unit compressor.

Fan Switch

In AUTO or INT (intermittent) mode, the blower operates only when the thermostat calls for heating or cooling. This mode is generally preferred when humidity control is a priority. The ON or CONT mode provides continuous indoor blower operation, regardless of whether the compressor or auxiliary heat are operating. This mode is required when constant air circulation or filtering is desired.

System Switch

Set the system switch for heating, cooling, or auto operation. The auto mode allows the heat pump to automatically switch from heating mode to cooling mode to maintain predetermined comfort settings. Many heat pump thermostats are also equipped with an emergency heat mode which locks out heat pump operation and provides temporary heat supplied by the auxiliary heat.

Indicating Light

Most heat pump thermostats have an amber light which indicates when the heat pump is operating in the emergency heat mode.

Temperature Indicator

The temperature indicator displays the actual room temperature.

Programmable Thermostats

Your system may be controlled by a programmable thermostat. These thermostats provide the added feature of programmable time-of-day setpoints for both heating and cooling. Refer to the user's information manual provided with your particular thermostat for operation details.

Preservice Check

If your system fails to operate, check the following before calling for service:

- Check to see that all electrical disconnect switches are ON.
- Make sure the thermostat temperature selector is properly set.
- Make sure the thermostat system switch is properly set.
- Replace any blown fuses, or reset circuit breakers.
- Make sure unit access panels are in place.
- Make sure air filter is clean.
- Locate unit model number and have it handy before calling.

Start-Up and Performance Checklist

Job Name _____ Job No. _____ Date _____

Job Location _____ City _____ State _____

Installer _____ City _____ State _____

Unit Model No. _____ Serial No. _____

Service Technician _____ Nameplate Voltage _____

Rated Load Ampacity _____ Compressor Amperage _____ Outdoor Fan _____

Maximum Fuse or Circuit Breaker _____

Electrical Connections Tight? Indoor Filter Clean? Supply Voltage (Unit Off) _____

Indoor Blower RPM _____ S.P. Drop Over Indoor (Dry) _____

Outdoor Coil Entering Air Temperature _____ Voltage with Compressor Operating _____

Outdoor Fan Checked?

Cooling

Liquid Line Pressure _____ Suction Line Pressure _____ Refrigerant Charge Checked?

Heating

Liquid Line Pressure _____ Suction Line Pressure _____ Refrigerant Charge Checked?

Refrigerant Lines: Leak Checked? Properly Insulated?

Service Valves: Fully Opened? Caps Tight?

Thermostat: Calibrated? Properly Set? Level?

Sequence of Operation

Heating Correct? Cooling Correct?

Single Stage Wire Diagram

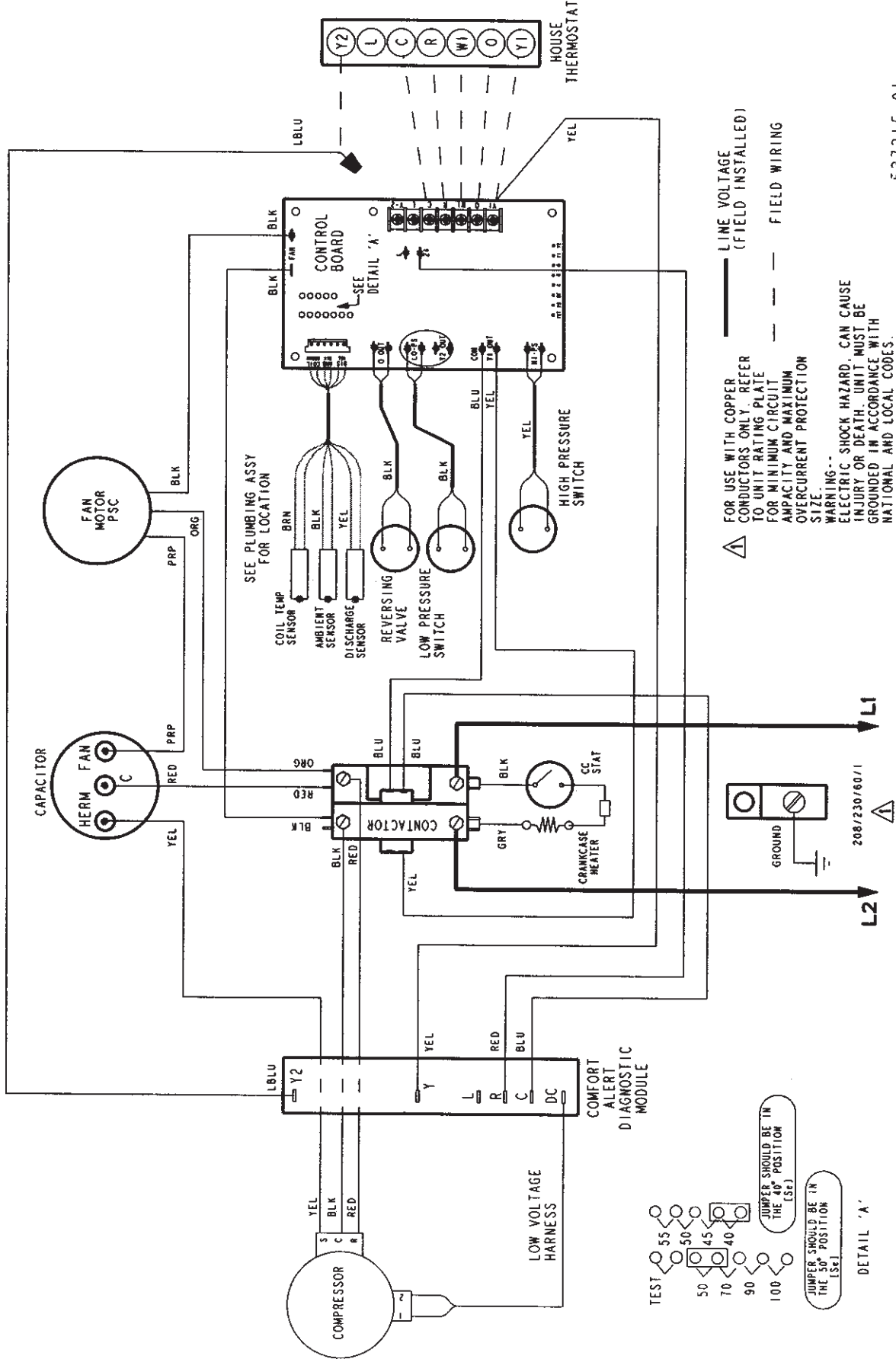

FOR USE WITH COPPER CONDUCTORS ONLY. REFER TO UNIT RATING PLATE FOR MINIMUM CIRCUIT AMPACITY AND MAXIMUM OVERCURRENT PROTECTION SIZE.
 WARNING-- ELECTRIC SHOCK HAZARD. CAN CAUSE INJURY OR DEATH. UNIT MUST BE GROUNDED IN ACCORDANCE WITH NATIONAL AND LOCAL CODES.

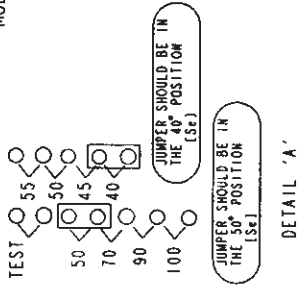

537315-01

Two Stage Wire Diagram

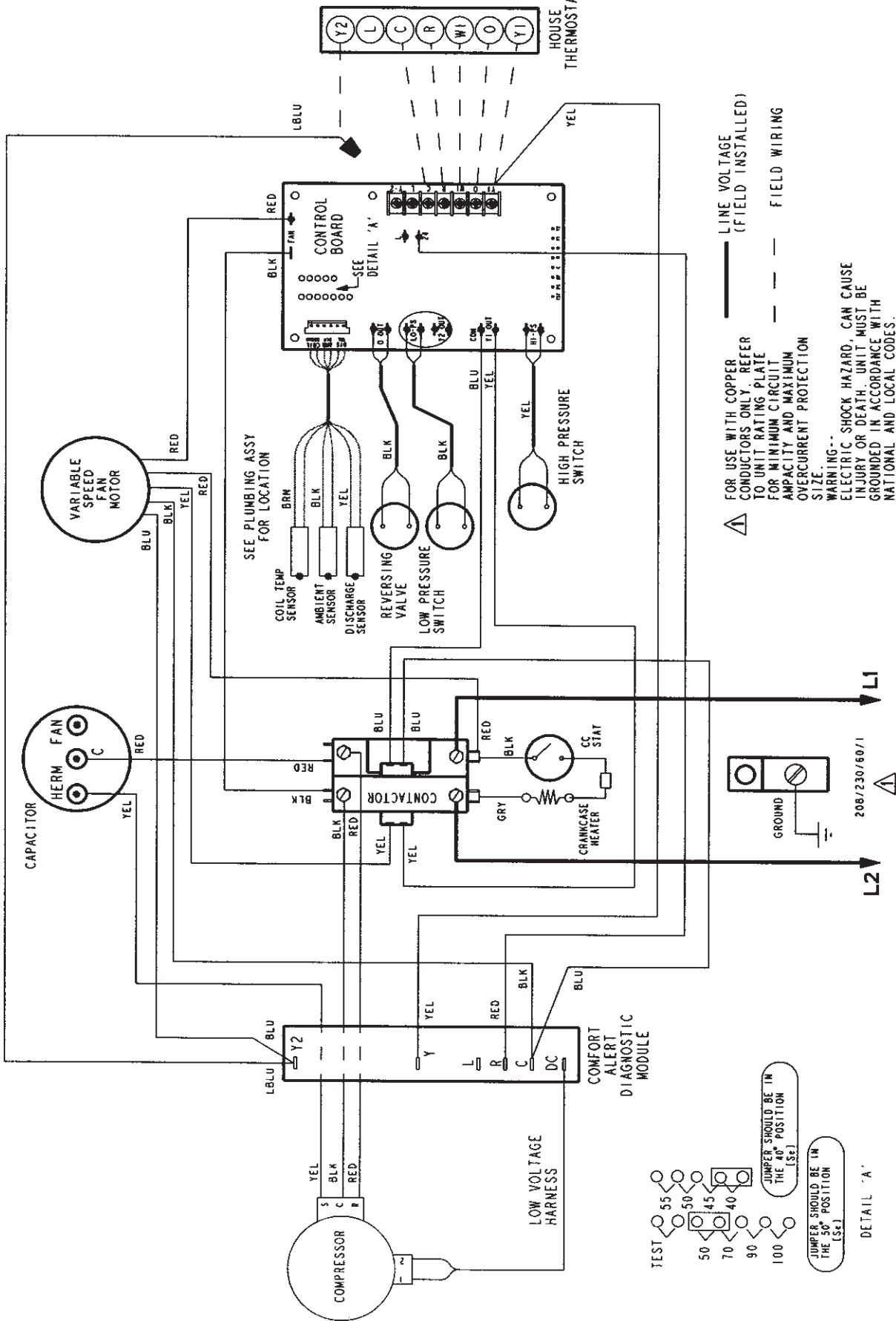

537329-01

(4SHPI6LTI60 MODEL ONLY)

Free Manuals Download Website

<http://myh66.com>

<http://usermanuals.us>

<http://www.somanuals.com>

<http://www.4manuals.cc>

<http://www.manual-lib.com>

<http://www.404manual.com>

<http://www.luxmanual.com>

<http://aubethermostatmanual.com>

Golf course search by state

<http://golfingnear.com>

Email search by domain

<http://emailbydomain.com>

Auto manuals search

<http://auto.somanuals.com>

TV manuals search

<http://tv.somanuals.com>