

Type ES76PK-1

7.6-Meter ESA

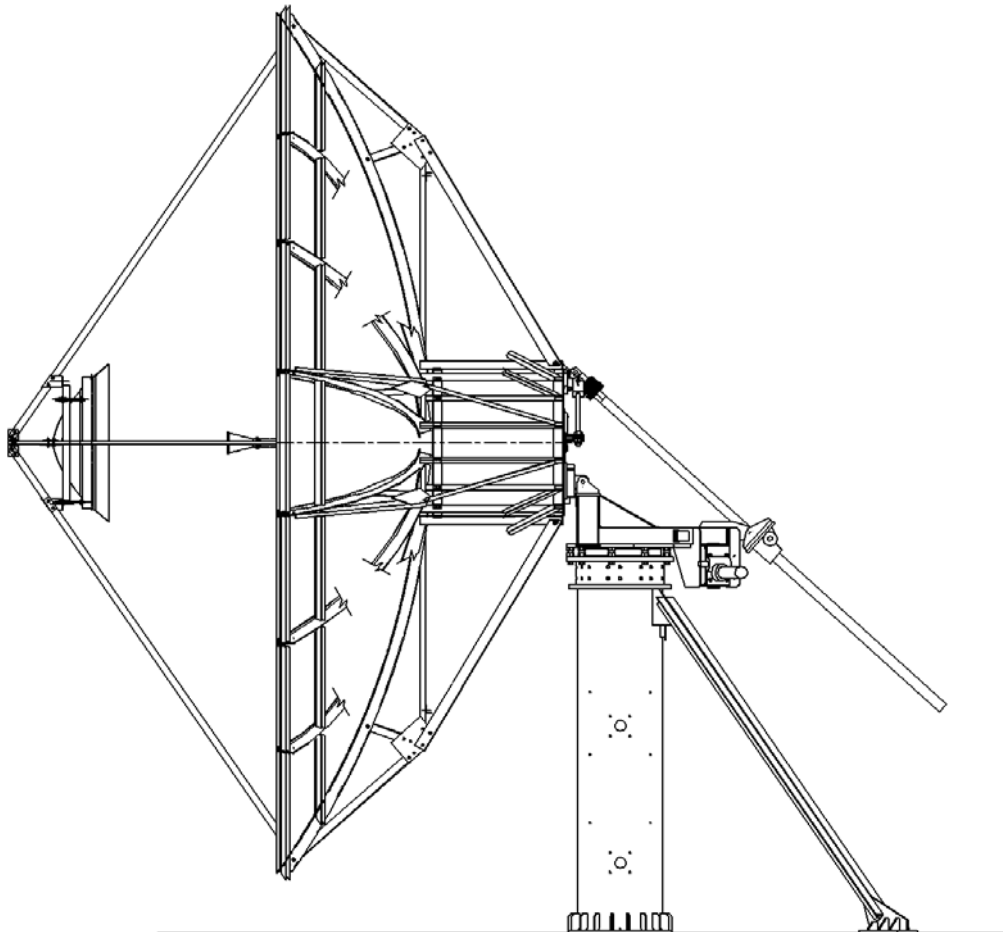

7.6-Meter Earth Station Antenna

Notice

The installation, maintenance, or removal of antenna systems requires qualified, experienced personnel. Andrew installation instructions have been written for such personnel. Antenna systems should be inspected by qualified personnel to verify proper installation, maintenance and condition of equipment.

Andrew Corporation disclaims any liability or responsibility for the results of improper or unsafe installation and maintenance practices.

All designs, specifications, and availabilities of products and services presented in this manual are subject to change without notice.

Andrew Corporation
10500 West 153rd Street
Orland Park, IL U.S.A. 60462

Telephone: 708-349-3300
FAX (U.S.A.): 1-800-349-5444
Internet: <http://www.andrew.com>

Customer Service, 24 hours: U.S.A. • Canada • Mexico: 1-800-255-1479
U.K.: 0800 250055 • Republic of Ireland: 1 800 535358
Other Europe: +44 1592 782612

16 August, 2005
Copyright © 2005 by Andrew Corporation

Table of Contents

Introduction	Introduction	3
	Proprietary Data	4
	Information and Assistance	4
	Notice	4
	Technical Assistance	4
How to Use This Manual	Overview	5
	Content	5
Getting Started	Overview	6
	Warnings	6
	Recommended Tools	7
	Parts Verification	8
	Reporting Equipment Loss or Damage	8
	Reporting Visible Loss or Damage	8
	Reporting Concealed Damage	8
	Inventory Equipment Received	8
	Returning Equipment	9
Installation Procedures	Overview	10
	Foundation Preparation	10
	A-325 Tensioning	11
	Pedestal Ground Mount Assembly	12
	Pedestal Installation	12
	Azimuth Jack Arm Installation	14
	Azimuth Jackscrew Assembly	16
	Elevation Jackscrew Assembly	19
	Reflector/Backstructure Assembly	20
	Reflector Alignment	27
	Theodolite Installation	27
	Reflector Alignment	32
	Reflector to Ground Mount Assembly	35
	Subreflector Installation	36
	Subreflector Centering	39
	Subreflector Focusing	39
Operation	Overview	40
	Acquiring A Satellite	40
	Subreflector Adjustment	44
	Survival Struts	44
Preventive Maintenance	Overview	45
	General Cleaning	45
	Electrical Parts	45
	Mechanical Parts	46
	Machined Surfaces (Not Galvanized)	46
	Inspection	46
	Local Control/Motor Drive Controller	46
	Antenna	47
	Drive System Voltage and Current Checks	49
	Preservation of Component Parts	51
	Aluminum Parts	51
	Galvanized Surfaces	51
	Lubrication	51
	Jackscrews/Motors	52
	Gear Motor/Housing Fill Drain Requirements	52



7.6-Meter Earth Station Antenna

Introduction

Like all Andrew earth station antennas, the 7.6-Meter Earth Station Antenna provides high gain and exceptional pattern characteristics. The electrical performance and exceptional versatility provides the ability to configure the antenna with your choice of linearly- or circularly-polarized 2-port or 4-port combining network. That versatility is provided at the time of initial purchase, as well as in the future, as your satellite communication requirements evolve.

The aluminum reflector is precision formed for accuracy and strength requiring minimal assembly. The reflector assembly is 25-feet (7.6-meters) in diameter and segmented in a sixteen piece configuration to reduce shipping volume and facilitate transport to remote sites. Reflector panels are chromate converted and painted with a highly reflective white paint.

The pedestal mount can be purchased with either manual or motorizable capabilities. The mount features 180 degree azimuth coverage in three continuous 120 degree overlapping ranges and executes 90 degree continuous elevation adjustment. This large adjustment range provides non-critical foundation orientation and the ability to view geostationary satellites from horizon-to-horizon, from any location worldwide.

The motorizable mount features self-aligning bearings for the elevation pivots, resulting in "zero" backlash. This mount can be operated manually, but has the ability to be upgraded for motorized operation, including steptracking/Smartrack™ applications.

The aluminum enclosure and hot-dipped galvanized steel mount maintain pointing accuracy and ensures durability and reliability. The antenna and standard manual mount with enclosure will survive 125 mph (200 km/h) wind, in any position of operation, without damage or permanent deformation in moderate coastal/industrial areas. The antenna will survive 200 mph (320 km/h) wind when properly stowed in the 90 degree elevation (zenith) position.

Andrew provides a complete line of available options, including motor drive systems (with power interfaces addressing domestic and international standards), remote micro-processor antenna control for motor drive systems, pressurization equipment, and inter-connecting HELIAX® cables and waveguide.



ANDREW® DO NOT DISCARD CONTENTS



The product in this packaging was placed in the market after August 13, 2005. Its components must not be discarded with normal municipal or household waste.

Contact your local waste disposal agency for recovery, recycling, or disposal instructions.

Proprietary Data

The technical data contained herein is proprietary to Andrew Corporation. It is intended for use in operation and maintenance of Andrew supplied equipment. This data shall not be disclosed or duplicated in whole or in part without express written consent of Andrew Corporation.

Information and Assistance

Andrew Corporation provides a world-wide technical support network. Refer to the technical assistance portion of this manual for the contact numbers appropriate to your location.

Notice

The installation, maintenance, or removal of antenna systems requires qualified, experienced personnel. Andrew installation instructions have been written for such personnel. Antenna systems should be inspected by qualified personnel to verify proper installation, maintenance and condition of equipment.

Andrew Corporation disclaims any liability or responsibility for the results of improper or unsafe installation and maintenance practices.

All designs, specifications, and availabilities of products and services presented in this manual are subject to change without notice.

Copyright © 2004, Andrew Corporation

Technical Assistance

24-hour Technical Assistance

For technical assistance, call the following numbers at anytime.

Call From	Call To	Telephone	Fax
North America (toll free)	U. S. A.	1-(800)-255-1479	(800)-349-5444
Any Location (International)	U. S. A.	(708)-349-3300	(708)-349-5410

Customer Service Center

The Andrew Customer Service Center gives you direct access to the information and personnel service you need, such as the following:

- Place or change orders
- Check price and delivery information
- Request technical literature

You can call from any of the following:

Call From	Telephone	Fax
North America	1-800-255-1479 (toll free)	1-(800)-349-5444 (toll free)
United Kingdom	00-800-0-255-1479 (toll free)	00-800-0-349-5444 (toll free)
Australia	0011-800-0-255-1479 (toll free)	0011-800-0-349-5444 (toll free)
China	00-800-0-255-1479 (toll free)	00-800-0-349-5444 (toll free)
New Zealand	00-800-0-255-1479 (toll free)	00-800-0-349-5444 (toll free)
Hong Kong	001-800-0-255-1479 (toll free)	001-800-0-349-5444 (toll free)



How to Use This Manual

Overview

The scope of this manual is intended to provide station personnel with the base installation, operation, and maintenance requirements necessary for a 7.6-Meter C-, X- or Ku-Band Earth Station Antenna. This manual provides a convenient reference for authorized operator/service personnel requiring technical information on general system or specific subsystem equipment.

The tables and figures presented in this manual are used as communication aids for the installation, operation, and maintenance of the 7.6-Meter Earth Station Antenna. These tables and figures instantly convey messages, as well as make the procedures easier to understand. This manual uses tables and figures for the following references:

- **Tables** The tables allow you to locate information quickly and easily.
- **Drawings** The drawings supplement the installation instructions by using a combination of graphics and verbage to assist you in simplifying complex procedures and clarifying components.
- **Photographs** The photographs compliment the installation instructions by providing actual examples of the steps being performed, which allow you to view the installation in concrete form.

Content

The manual is divided into five distinct sections, each dealing with a specific technical topic relating to either system or component subsystem information. The sections contained in this manual are described and listed under the following technical headings:

- **How to Use This Manual** Describes the manual's purpose, content, and communication aids. Additionally, this section lists the related documentation for the 7.6-Meter Earth Station Antenna.
- **Getting Started** Provides the preliminary information needed to perform a successful installation. This section should be reviewed prior to the installation. The warnings, recommended tools, parts verification, instructions on reporting lost or damaged equipment, and installation checklist are located in this section.
- **Installation Procedures** Provides the procedures for the different phases of a 7.6-Meter Earth Station Antenna base installation. This section will help you easily find requirements for an individual task, as well as displays the sequence for each task execution.
- **Operation** Describes the controls, functions, and general operating procedures required for proper operation of the 7.6-Meter Andrew Earth Station Antenna.
- **Preventive Maintenance** Describes preventive maintenance procedures that are required to maintain proper functional operation of your new Andrew Earth Station Antenna.

Getting Started

Overview

The installation, operation, and maintenance of the 7.6-Meter Earth Station Antenna requires qualified and experienced personnel. Andrew installation, operation, and maintenance instructions are illustrated for such personnel. Additionally, the antenna should be inspected by qualified personnel to verify proper installation, maintenance, and condition of equipment as described in Preventive Maintenance. The basic equipment and accessories are either manufactured or design controlled by Andrew Corporation.

The prerequisite information necessary for the 7.6-Meter Earth Station Antenna can be found in this section. Furthermore, this section should be reviewed BEFORE performing the installation, operation, or maintenance. Warnings, recommended tools, and the antenna parts can be verified and/or determined with such a review.

Warnings

When installing the 7.6-Meter Earth Station Antenna, be conscious of the warnings presented below. For further information or clarification of this information, contact the Customer Service Center. The warnings are as follows:

1. Electrical shock from voltages used in this antenna system may cause personal injury or death. Prior to making any electrical connections or performing maintenance or repair, ensure that the power is removed. Electrical connections should be made only by qualified personnel in accordance with local regulations.
2. Installation of antennas may require persons to work at elevated work stations. Whenever persons are working at eight or more feet above the ground and not on a guarded platform, they should wear safety belts with at least one (preferably two) lanyards.
3. Never stand underneath any object while it is being lifted.
4. Always wear a hard hat, especially if someone is above you.
5. Make sure no person is in or under the reflector while it is being lifted or positioned; personal injury can result if the reflector assembly falls.
6. Personnel should never be hoisted in or out of the reflector by the crane; personal injury may result.
7. Andrew earth station antennas supplied to standard product specifications will survive 125 mph (200 km/h) winds in any operational position in moderate coastal/industrial areas. Severe conditions require additional protection.
8. Should it be expected that winds will exceed 125 mph (200 km/h), it is recommended that Andrew antennas be steered to specific azimuth and elevation orientations to minimize wind forces upon the structure and thereby increase the probability of survival. Position the antenna to an elevation of zero degrees. The azimuth jackscrew should be placed in the center of its travel. It is recommended that all cross-axis waveguide and coaxial cables are secure such that high winds will not cause excessive flexing.
9. When the antenna is transmitting, severe eye injury or injury to other parts of the body can result from exposure to radio frequency (RF) energy. The antenna must be turned off before entering the area in front of the reflector and near the feed.

NOTE: Failure to follow an installation procedure could result in damage to equipment or personal injury.

Additional warnings will be displayed throughout this manual for your awareness. These warnings can be identified in warning boxes as shown in the following sample.



Andrew disclaims any liability or responsibility for the results of improper or unsafe installation, operation, or maintenance practices.

Recommended Tools

Andrew supplies all appropriate hardware/parts required for the installation of your 7.6-Meter Earth Station Antenna. All tools necessary for the installation process should be provided by the installation crew. Andrew recommends the following tools to be used for a proper installation of the 7.6-Meter Earth Station Antenna.

Tool	Size	Quantity	
Open End or Combination Wrenches	5/16 Inch	2	
	7/16 Inch	2	
	9/16 Inch	2	
	7/8 Inch	2	
	3/4 Inch	2	
	1/2 Inch	2	
	1-1/4 Inch	1	
Crane	2 Ton Minimum Capacity, extended end	1	
Nylon Web Slings (2000 pound breaking strength)	3 Inch by 14 Foot	2	
Rope or Cord (2000 pound breaking strength)	50 Foot	1	
Shackles	5/8 Inch	4	
Ladder	10 Foot Extension	1	
Drive Sockets	1/16 Inch	1	
	9/16 Inch	1	
	7/8 Inch	1	
	3/4 Inch	1	
	1-1/4 Inch	1	
	Breaker Bar	1/2 Inch	1
	Spud Wrenches	1-1/16 Inch	1
1-1/4 Inch		1	
Screw Driver	Standard	1	
	Phillips	1	
Allen Wrench	7/64 Inch	1	
	3/16 Inch	1	
	1/4 Inch	1	
Tape Measure (or other measuring device)	Standard	1	
Felt-tip Marker (or other marking device)	Standard	1	
Hammer	Standard	1	
Rubber Mallet	Standard	1	
Pry Bar	Standard	1	
Tin Snips	Standard	1	
Safety Gloves (each installer)	Standard	1	

Table 2-1. Recommended Tools

Parts Verification

Upon receipt of your order, the shipment should be verified to ensure that all parts have reached your site. This process should occur before the installation process begins.

Andrew Corporation thoroughly inspects and carefully packs all equipment before shipment. If you find that there are missing components, please refer to page 9 for step-by-step instructions on how to properly report the equipment loss.

When you have received your order, verify that all parts contained in the shipment correspond to the parts listed on your packing list.

Reporting Equipment Loss or Damage

If you find that there was damage caused to the equipment during the shipping process, a claim should be filed with the carrier. Follow the "Reporting Visible Loss or Damage" or "Reporting Concealed Damage" procedures when filing a claim with the carrier.

Reporting Visible Loss or Damage

Make a note of any loss or evidence of external damage on the freight bill or receipt, and have it signed by the carrier's agent. Failure to adequately describe such external evidence of loss or damage may result in the carrier refusing to honor a damage claim. The form required to file such a claim will be supplied by the carrier.

Reporting Concealed Damage

Concealed damage means damage which does not become apparent until the unit has been unpacked. The contents may be damaged in transit due to rough handling, even though the carton may not show external damage. If you discover damage after unpacking the unit, make a written request for an inspection by the carrier's agent, then file a claim with the carrier since such damage is most likely the carrier's responsibility.

Inventory Equipment Received

After opening your shipment, an inventory of the parts should occur immediately. Check each item received in your shipment against the packing slip included with the shipment. If any items are missing, please notify Andrew Corporation immediately by contacting the Customer Service Center.

Returning Equipment

Andrew Corporation tries to ensure that all items arrive safe and in working order. Occasionally, despite these efforts, equipment is received which is not in working condition. When this occurs, and it is necessary to return the equipment to Andrew Corporation for either repair or replacement, return can be expedited by following the procedure listed below:

Step 1

Call the Andrew Customer Service Center and request a Return Material Authorization (RMA) number, as well as an address to forward the material to.

Step 2

Tag or identify the defective equipment, noting the defect or circumstances. Also, be sure to write the RMA number on the tag. It would be helpful to reference the sales order and purchase order, as well as the date the equipment was received.

Step 3

Pack the equipment in its original container with protective packing material. If the original container and packing material are no longer available; pack the equipment in a sturdy corrugated box, and cushion it with appropriate packing material.

Step 4

Be sure to include the following information when returning the equipment:

- Your Company Name
- Your Company Address
- City, State, and Zip Code
- Telephone Number
- RMA Number
- Problem Description
- Contact Name

NOTE: Absence of the RMA number will cause a delay in processing your equipment for repair. Be sure to include the RMA number on all correspondence.

Step 5

Ship the equipment to Andrew Corporation using UPS, U.S. Postal Service, or other appropriate carrier; freight prepaid and insured. The material should be forwarded to the address given by the Andrew contact in Step 1.

Installation Procedures

Overview

This section provides installation procedures for the 7.6-Meter Andrew Earth Station Antenna. The installation procedures include instructions on the following antenna components:

- Mount
- Reflector
- Enclosure
- Reflector-to-Mount Assembly
- Subreflector

Foundation Preparation

Before beginning the installation process on the ground mount assembly, ensure that the foundation has been prepared. Foundation specifications are provided by Andrew and may be used as a reference by civil engineering personnel when preparing the foundation for local soil conditions. These specifications are available before the shipment arrives by contacting the Customer Service Center or your Account Manager.

- Foundation should be dimensioned as detailed in Figure 1.
- Sweep foundation clear of any dirt or debris.
- To ensure smooth surface for mount, scrape foundation pad.
- Studs should extend 6 in. (152mm) above the ground and are 1-1/4 in.(32mm) diameter
- Apply Stick Wax (200852) to stud threads to ease later connections.

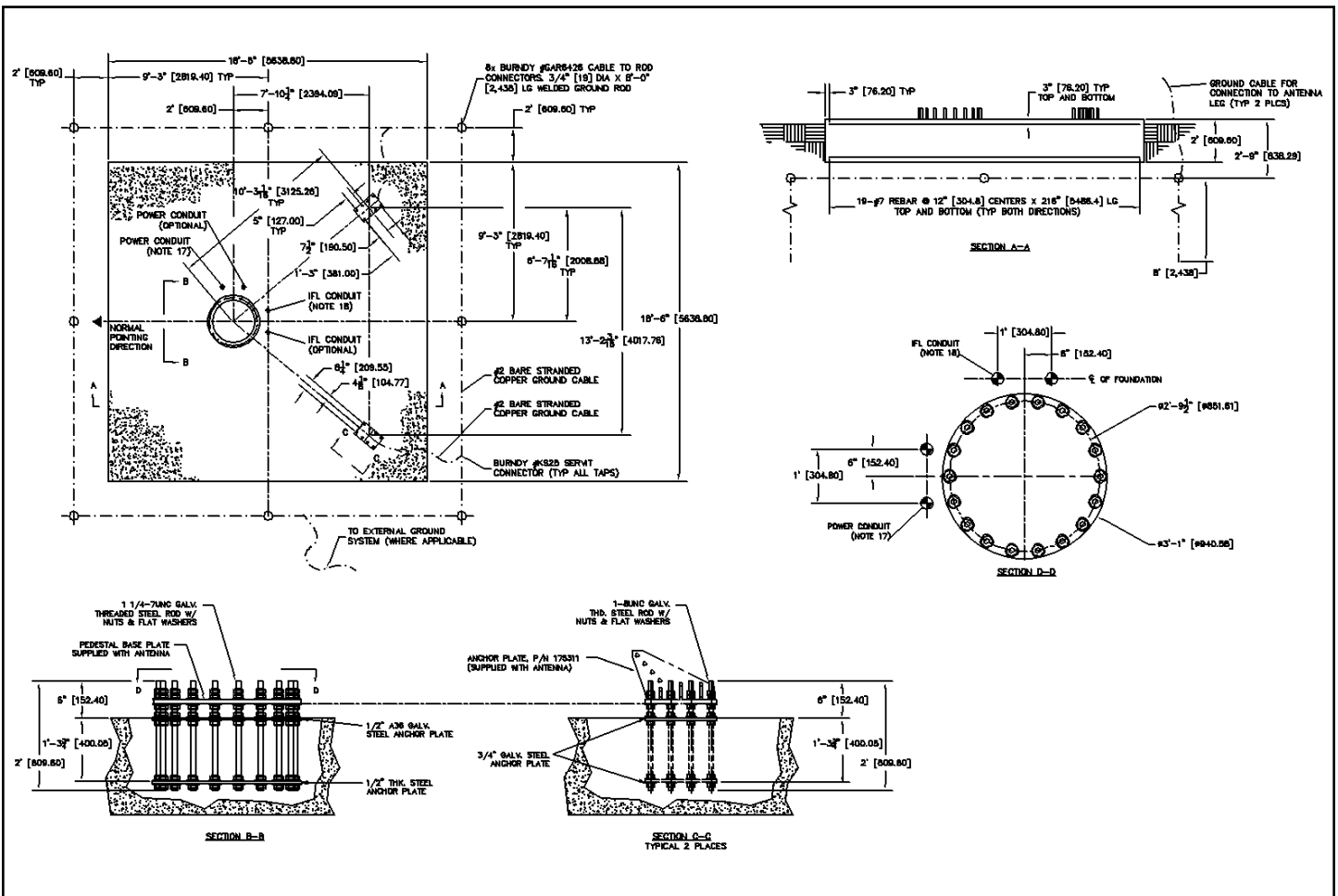

Figure 1

A-325 Tensioning

During the installation process, there are several references to the A-325 hardware tensioning procedure. The A-325 hardware must be properly tensioned to avoid slippage between bolted surfaces under high loads. Slippage can cause the corresponding assembly to move, causing antenna misalignment. When designated, the A-325 hardware should be tightened according to the following tensioning procedure.

NOTE: Tensioned bolts are for final connections only and should not be loosened for reuse.

- Step 1** Lubricate the bolt threads with the provided stick wax to reduce friction.
- Step 2** Insert the bolt, and add a flat washer—if required. **Do not** allow wax under the flat washer.
- Step 3** Add the nut, and finger tighten.
- Step 4** After the connections are complete, tighten the bolts until the surfaces are joined and the nuts are snug (for example, full effort of a person using an ordinary spud wrench). Do not proceed with Steps 5 and 6, unless the connection is final and is not intended to be loosened again.
- Note:** If the bolts are loosened after Steps 5 and 6, discard and replace with new hardware.
- Step 5** Using a felt-tip marker, mark the nuts and the ends of the bolts with a straight line as shown in Figure 2-1a and Figure 2-1b.
- Step 6** Tighten the nuts further with an extra long wrench until the nuts are moved 1/3 turn (120 degrees) as shown in **Figure 2-1a for bolt lengths less than four diameters** and 1/2 turn (180 degrees) as shown in **Figure 2-1b for bolt lengths over four diameters**.

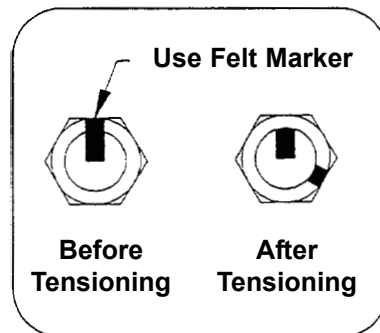

Figure 2-1a: A-325 Tensioning Procedure For bolts less than 4 diameters

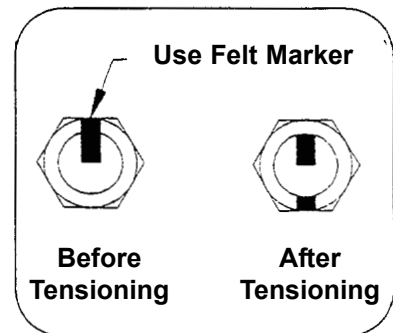

Figure 2-1b: A-325 Tensioning Procedure For bolts over 4 diameters

Pedestal Ground Mount Assembly

Pedestal Installation

Step 1

The Pedestal Mount is an elevation-over-azimuth mount optimized for geostationary satellite applications. The mount enables continuous elevation adjustment from 0 to 90 degree. The azimuth axis has over 180 degrees of travel with 120 degrees (+/-60 deg.) of continuous travel at each jack position. The jack can be positioned every 45 deg. around the pedestal tube. Follow the subsequent procedures for proper installation of pedestal ground mount assembly.

All ground mount hardware is type A325. Lubricate all A325 bolt threads with supplied stick wax. **Note:** Do not tighten hardware until ground mount installation is complete unless otherwise instructed.

Step 2

Use a crane to carefully lift the pedestal assembly (303613) and place it over the corresponding foundation bolts as shown in Figure 3. **Note:** Ensure pedestal assembly is oriented on the foundation bolts as shown. Pedestal weight = approx. 3800 lbs. (1724 kg.)

- Use 1-1/4 in. (32mm) hardware.

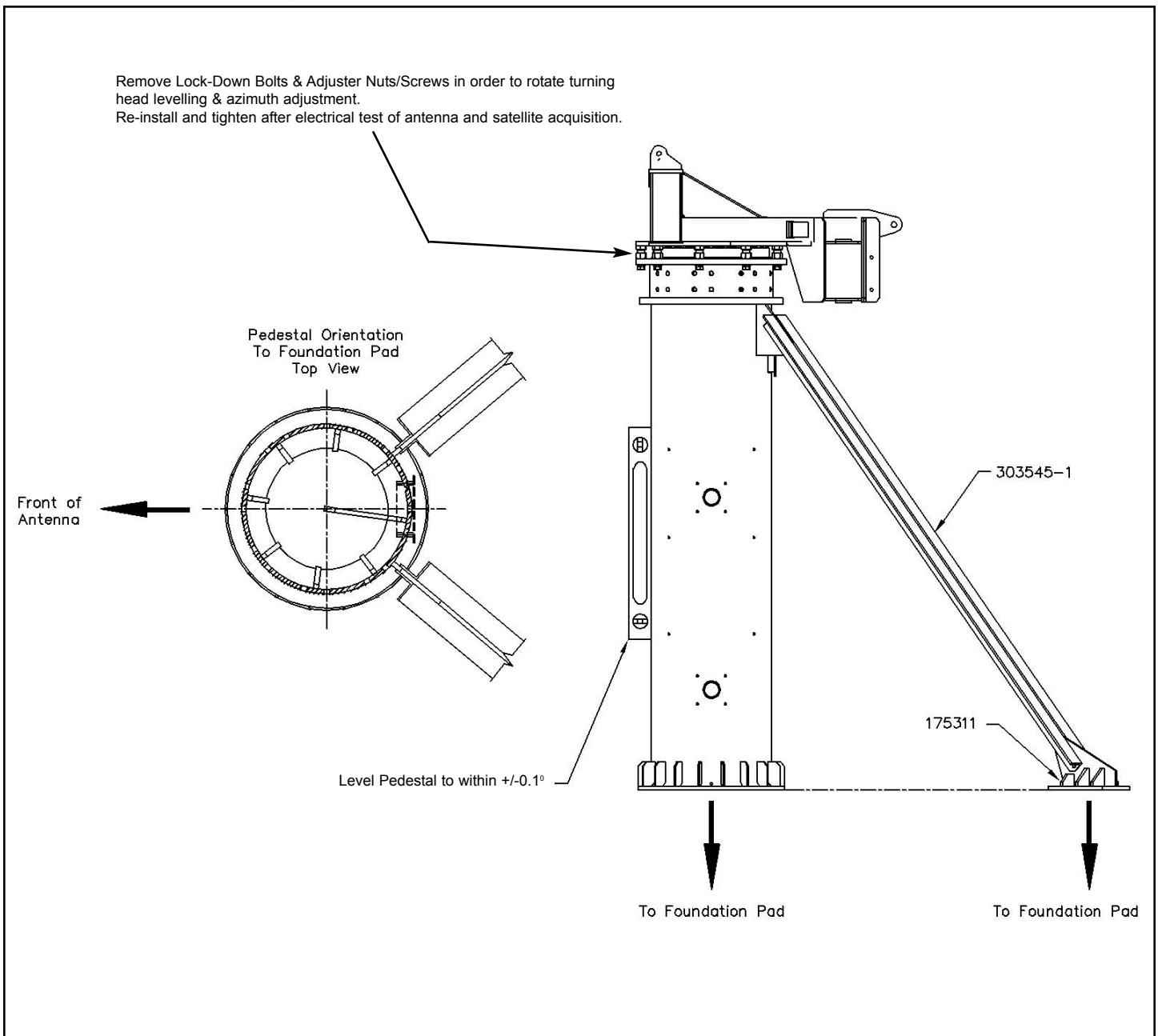

Figure 3

Step 3

Using the 1-1/4 in. foundation hardware supplied, level the pedestal to within +/-0.1 degrees. Tighten each anchor bolt to 912 lb/ft (126 kg/m) as shown in Figure 4. **Note:** Tighten each bolt using no more than 300 lb/ft (41.5 kg/m) at a time **in tightening sequence shown.**

- Use 1-1/4 in. flatwashers and hex nuts.

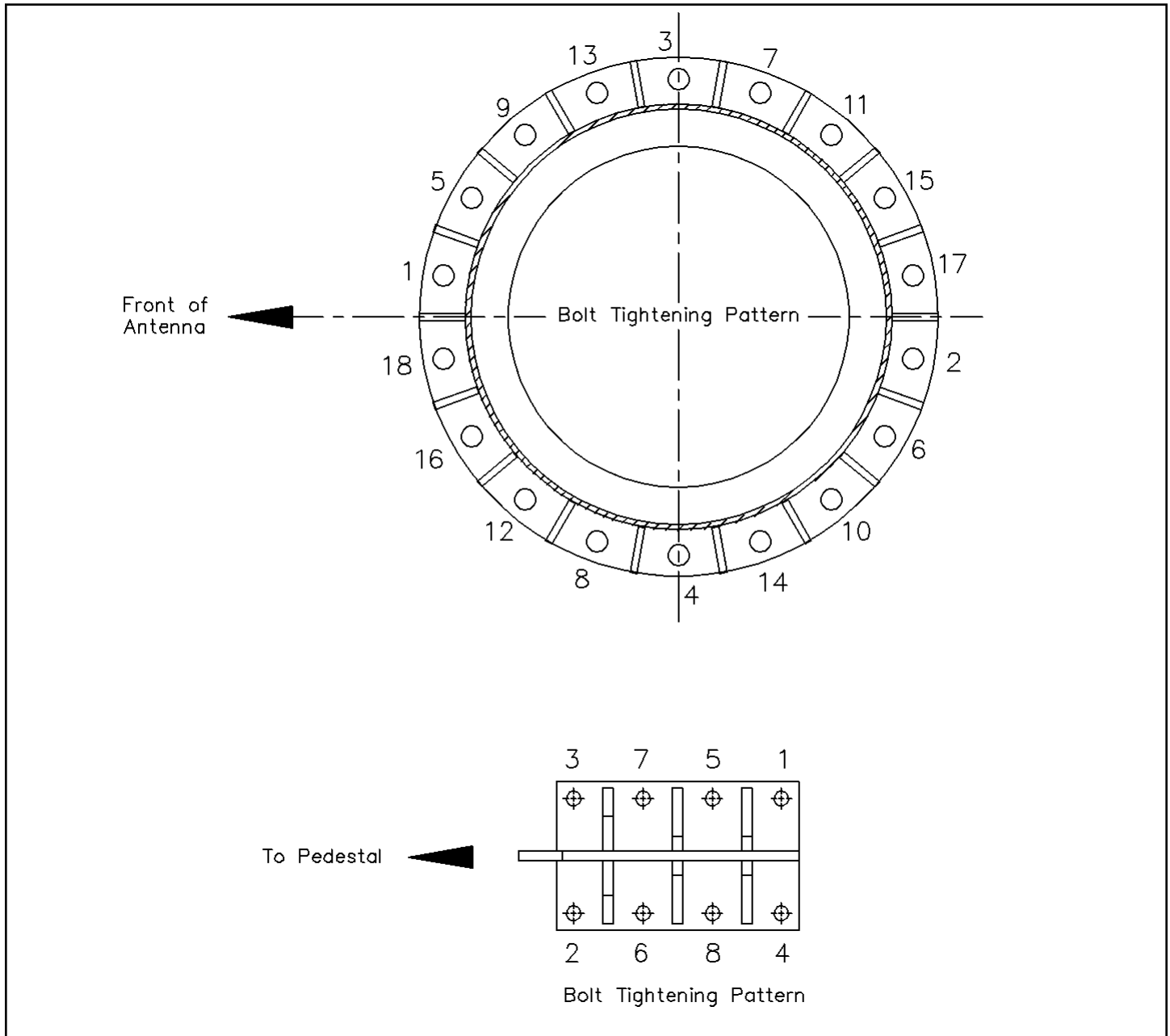

Figure 4

Step 4

Place Anchor Plates (175311) over the corresponding anchor bolts as shown in Figure 3. **Note:** Ensure anchor plates are oriented on the foundation bolts as shown, level and on same datum as the pedestal assembly.

Using the foundation supplied hardware, tighten each anchor bolt to 912 lb/ft (126 kg/m) as shown in Figure 4. **Note:** Tighten each bolt using no more than 300 lb/ft (41.5 kg/m) at a time in **tightening sequence shown**.

Step 5

Loosely fasten the two halves (303545-101 & 303545-3) of the support struts (303545-1) together using 7/8" bolt, nut and washer.

Step 6

Secure the struts into place keeping clipped end of angles toward strut anchor plates. Attach struts to pedestal assembly and tighten all strut/plate hardware using procedure for A325 hardware.

- Use 7/8" x 3-1/2" A325 bolts, nuts and washers for each connection.

Azimuth Jack Arm Installation

Step 1

Attach 302383 Azimuth Jack Arm assembly to 303613 pedestal assembly as shown in Figure 5.

- Use 1" x 5" A325 bolts, nuts and washers for each connection.

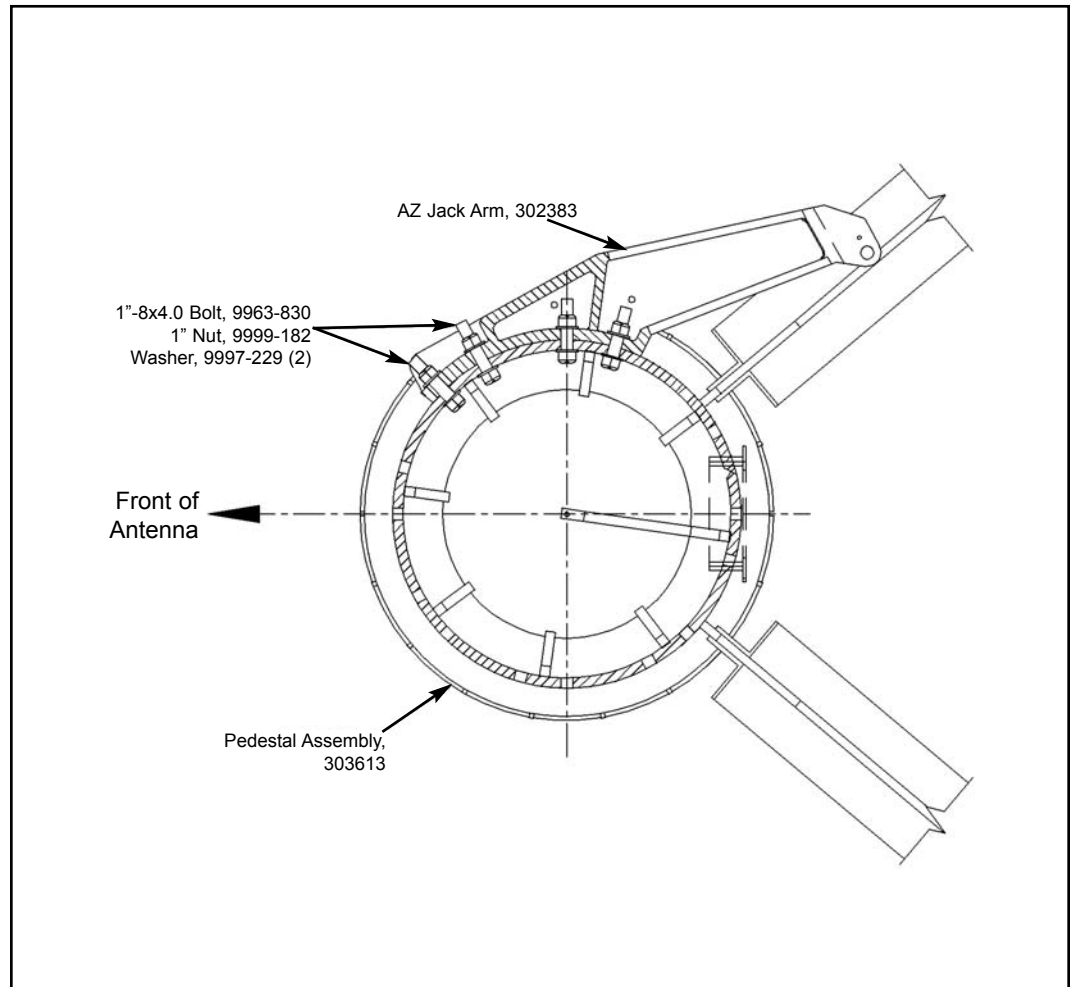

Figure 5

Azimuth Jackscrew Assembly

Step 1

Raise the Azimuth Jack assembly into place and attach it to the pedestal assembly as shown in Figure 7. **NOTE:** The bolts attaching the trunnion to the jack are supplied loose, this hardware must be torqued once the jack is installed and aligned (see Figure 7).

- Install Azimuth Trunnion Pin (302164).
- Use 3/8 x 1 in. capscrew, washer and lock washer.

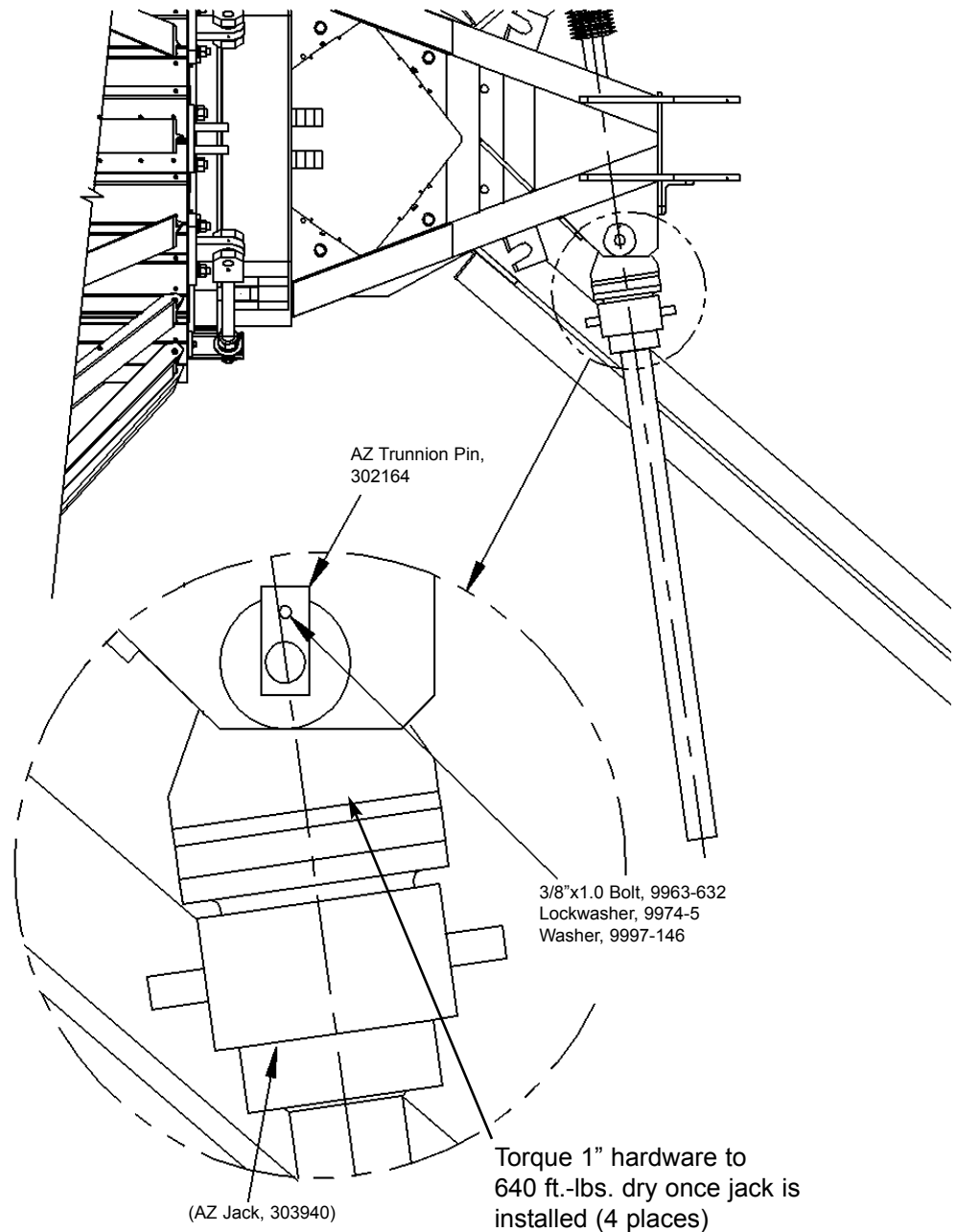

Figure 7

Step 2

Attach Azimuth Jack rod end assembly to the Azimuth Jack Arm as shown in Figure 8.

- Use Azimuth Pin (302168) and 3/8 x 1 in. capscrew, washer and lock washer.

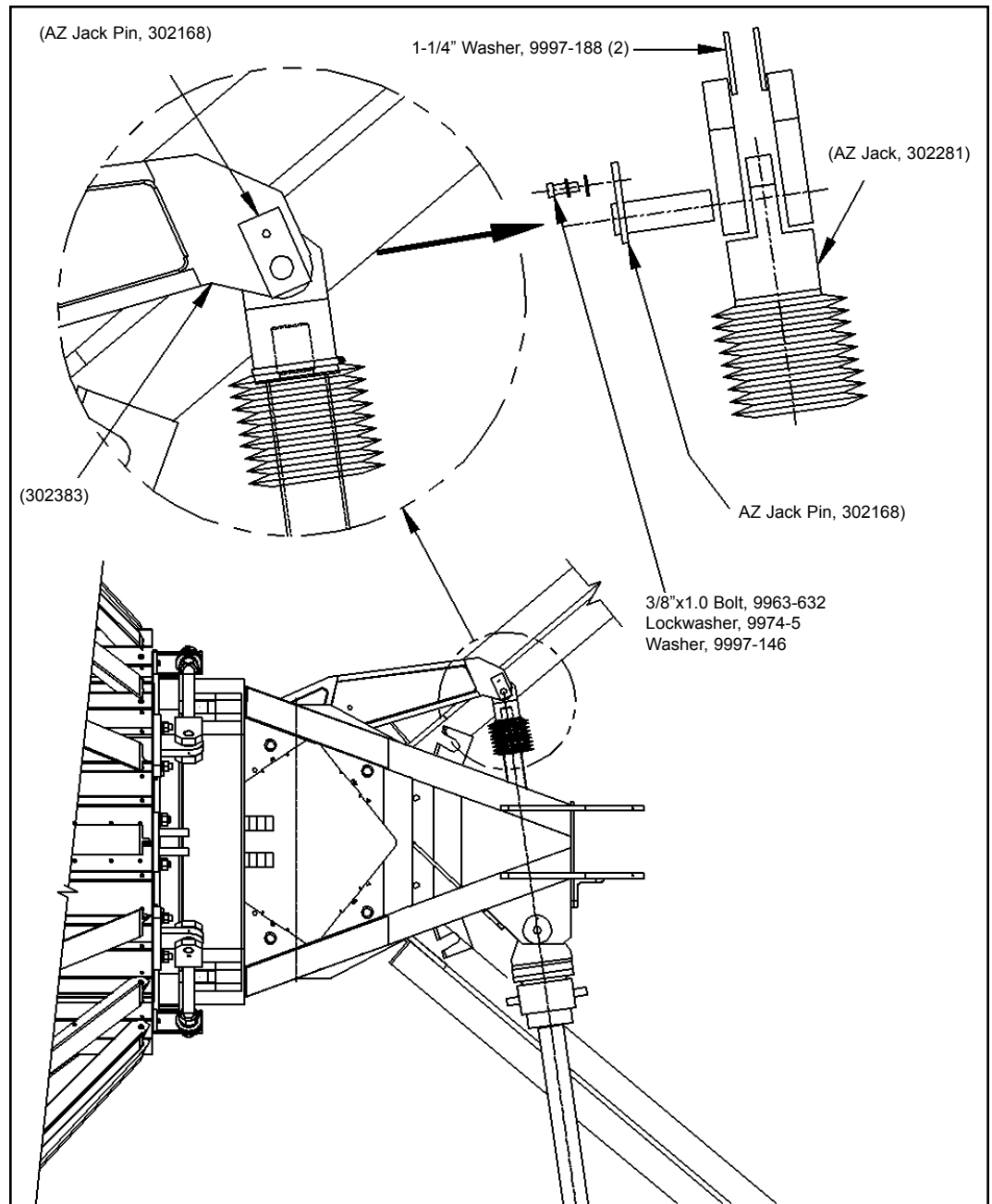

Figure 8

Elevation Jackscrew Assembly

Step 1

Raise and attach the Elevation Jack assembly to the pedestal assembly as shown in Figure 10. Fully retract the Elevation Jack to its minimum length. **NOTE:** The bolts attaching the trunnion to the jack are supplied loose, this hardware must be torqued once the jack is installed and aligned (see Figure 10).

- Use Elevation Trunnion Pin (303725) and 3/8 x 1 in. capscrew, washer and lockwasher.

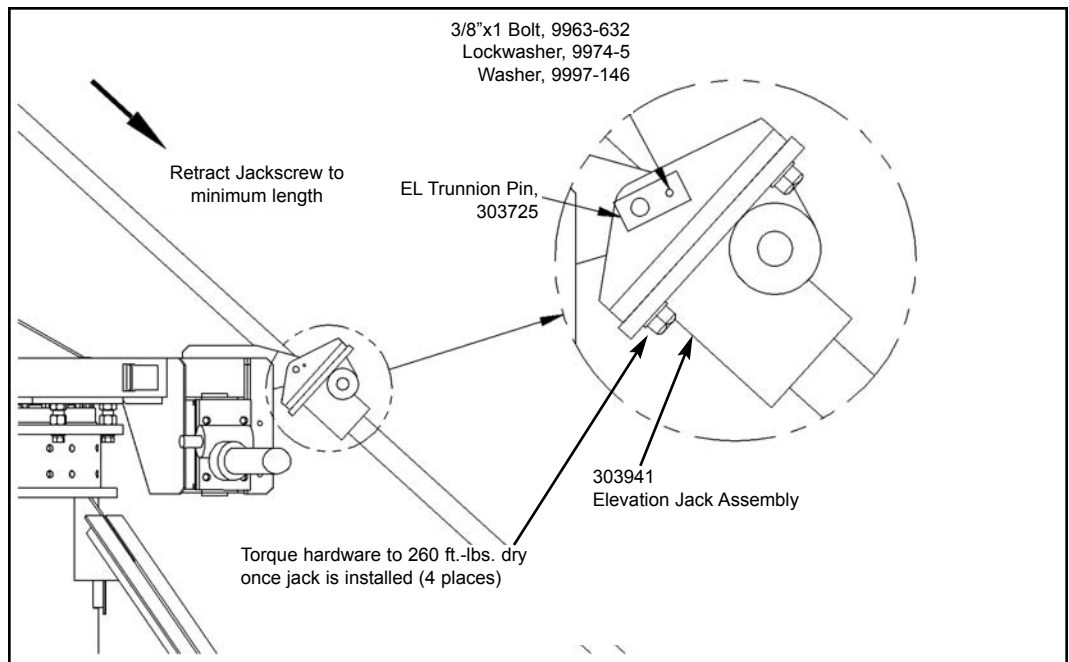

Figure 10

The ground mount assembly is now completed with the necessary essentials. All ground mount options have separate instructional bulletins located in the Parts Kit that contain the option.

The next step in the installation process is the Reflector Assembly. Proceed to the next page to begin installation of the reflector.

WARNING

Assembly and installation of Reflector/Backstructure should only take place when winds are less than 15 mph (24 km/h) to prevent damage to reflector panels and ease the assembly process. Follow special instructions stenciled on crate relative to crate opening, contents removal and/or personnel safety.

Reflector/ Backstructure Assembly

Step 1

Note

Lubricate bolt threads of both stainless steel and A325 hardware with supplied Stick Wax (200852) to reduce friction. Do not allow wax under flat washer.

Refer to Figure 11. Position Enclosure Assembly (303659) upside down on four temporary wood support blocks. The blocks should be positioned equally around the enclosure's perimeter.

Remove the Rear Enclosure Panel. With one person inside the enclosure and one person on the outside, attach Short Struts (220915) to the enclosure as per Detail A and B.

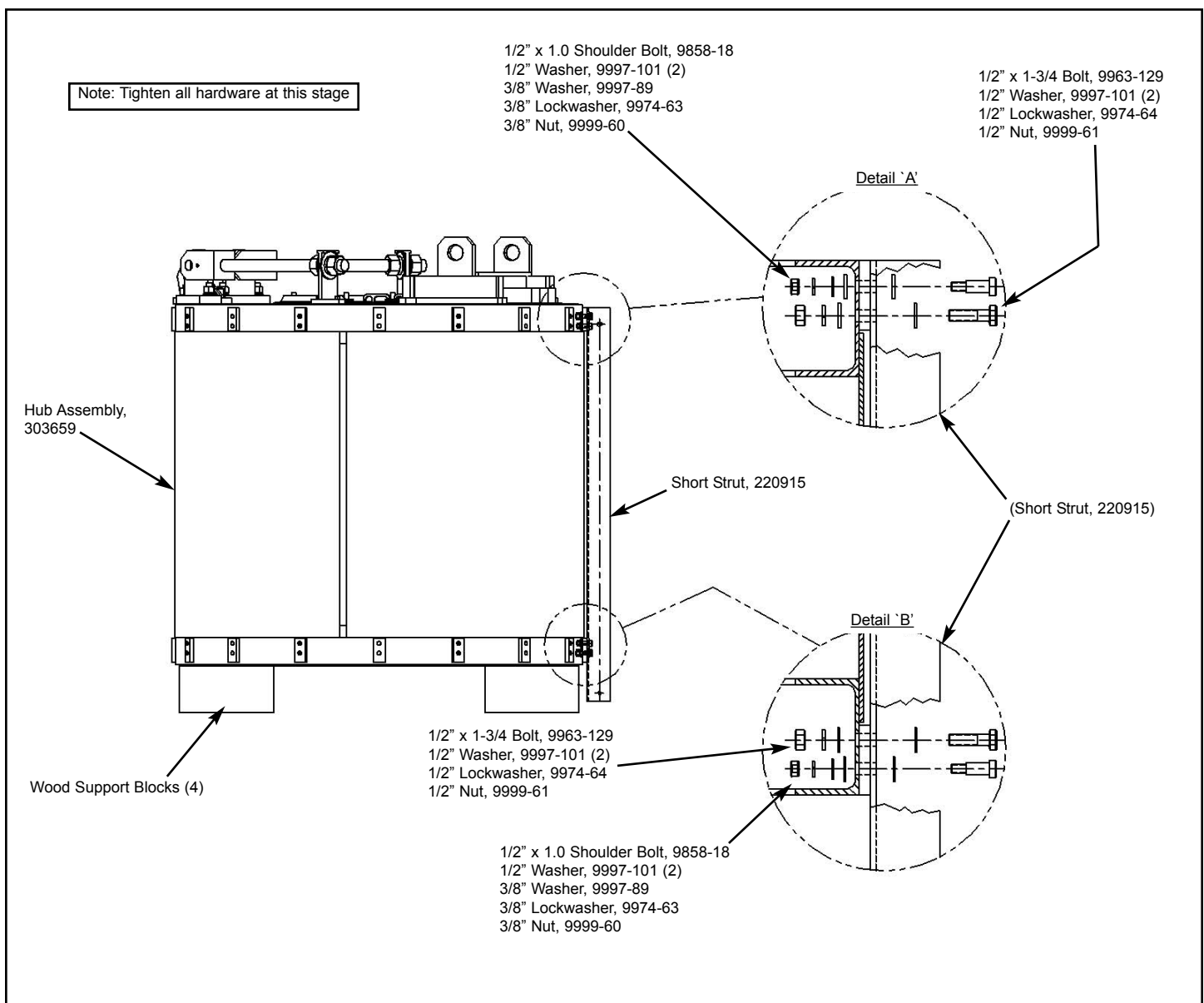

Figure 11

Step 2

Once all 16 Short Struts are installed and securely fastened, re-install Rear Enclosure Panel. Carefully rotate the enclosure right-side-up as shown in Figure 12. Place temporary wood blocks under each of the enclosure's three support pads with the additional block positioned in between.

Step 3

Install Ribs (222673) to enclosure strut as shown in Figure 12. Attach Target Screws supplied from Alignment Kit (223711) as shown and tighten. Leave all other hardware loose.

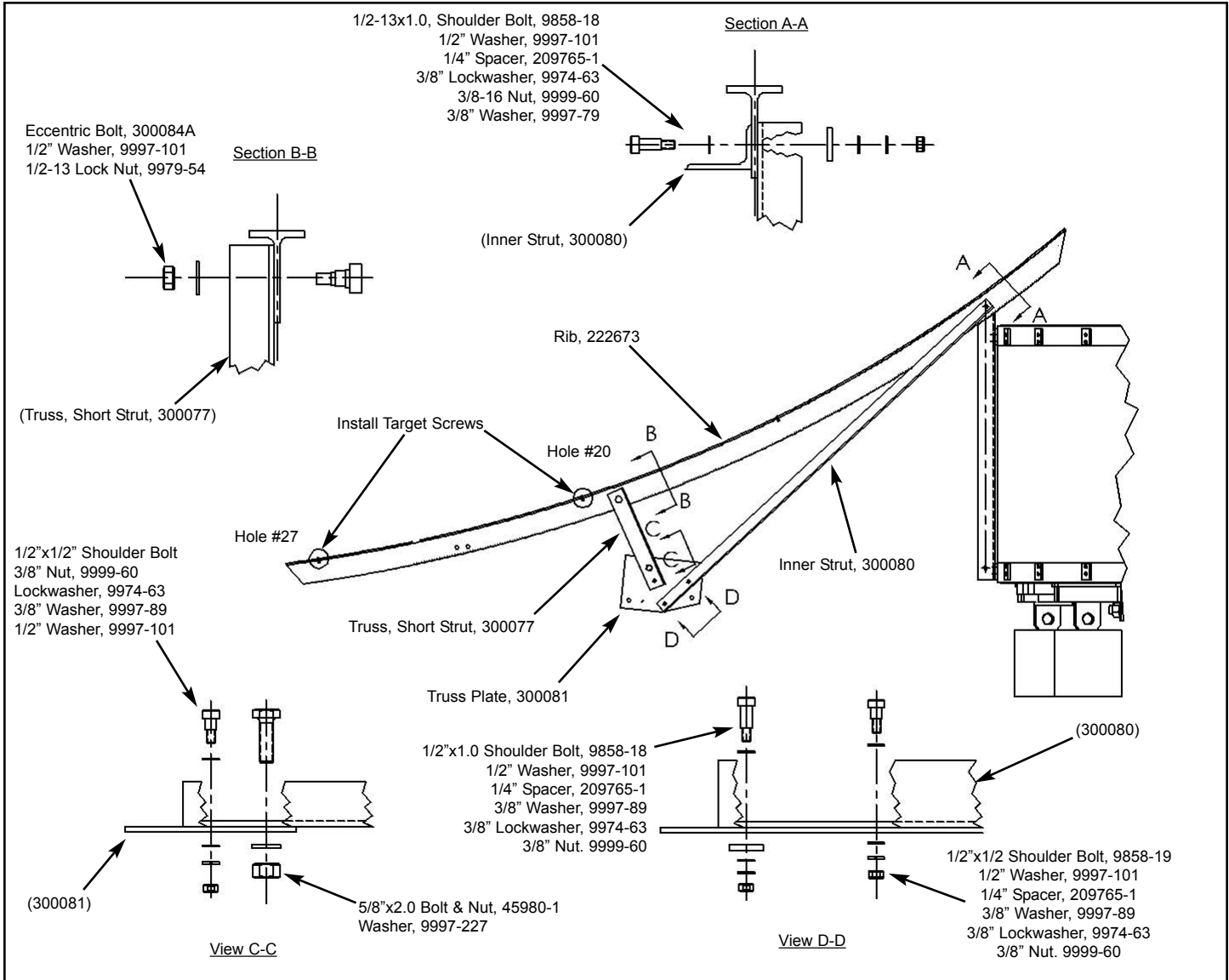

Figure 12

Step 4 | Install Outer Strut to assembly as shown in Figure 13. Leave hardware loose.

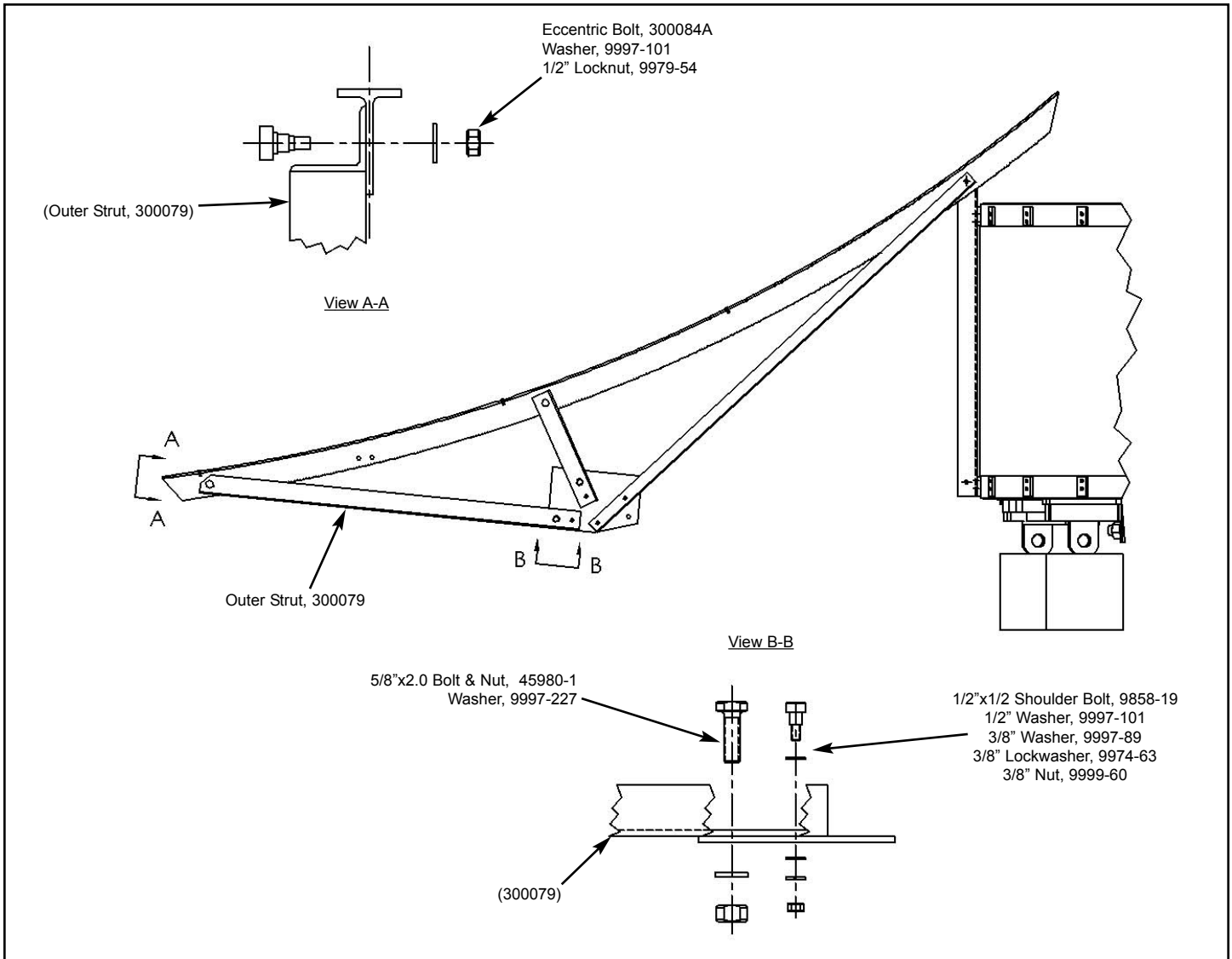

Figure 13

Step 5 Lift truss/rib assembly and install Long Strut as shown in Figure 14. Note: the Long Strut is installed on the opposite side of the Truss Plate. Refer to Figure 12, View D-D for previously installed hardware for Inner Strut to Truss Plate connection. Leave hardware loose.

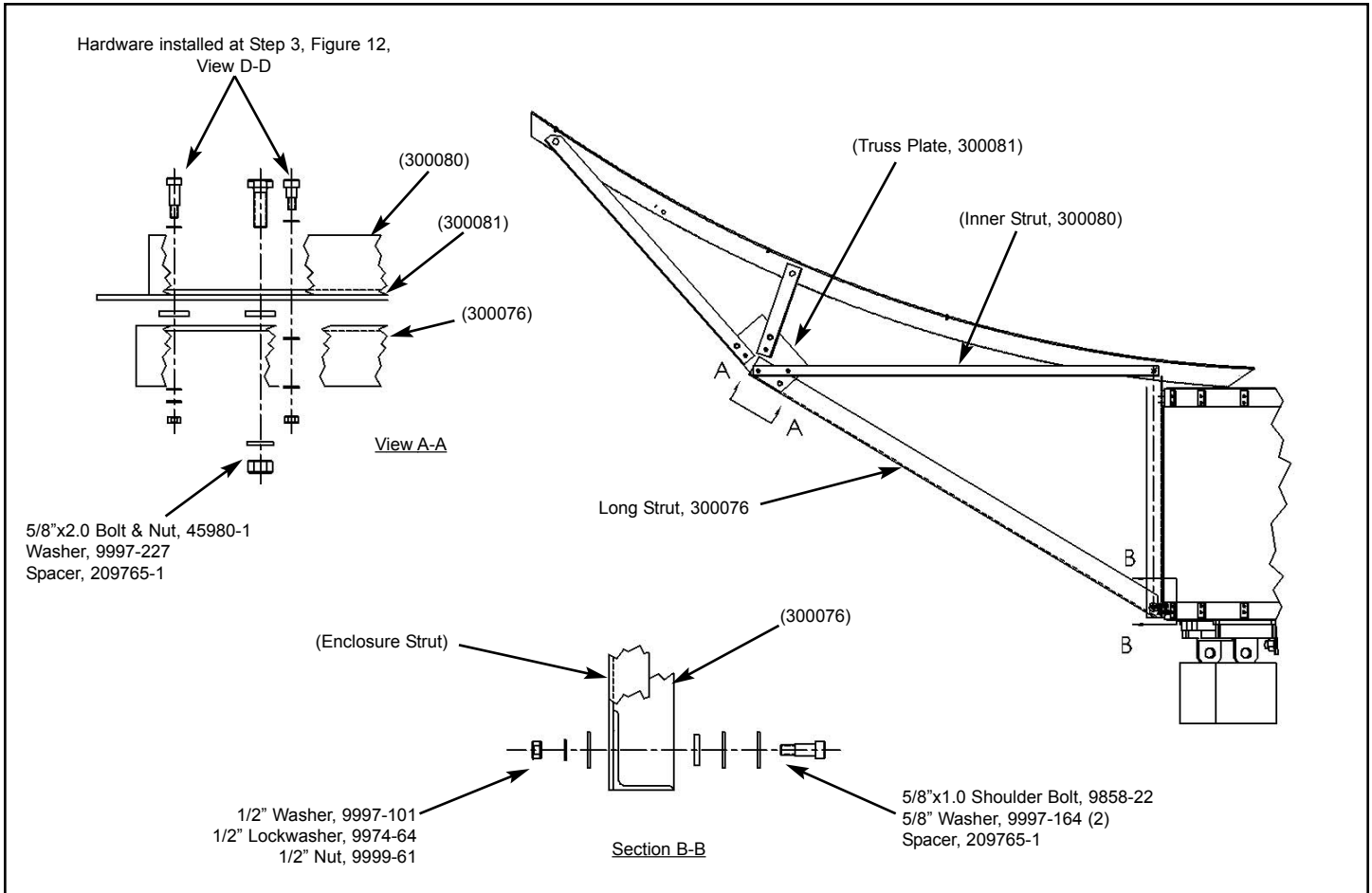

Figure 14

Step 6 Securely Tighten all stainless steel shoulder bolts first. Next, tighten all A325 hardware following Tensioning Procedure on page 11.
NOTE: Do not tighten eccentric bolts (300084A) until Alignment Procedure specifies.

Step 7 Attach stretch-formed Skirts (222765-2), Strip Spacer (300040) and Inboard Skirt (300082-2) to Reflector Panels (222677) before attaching panels to ribs. Refer to Figure 15, Section A-A & View B-B. Do not install outer-most screw on each side of skirt at this time.

NOTE: Do not overtighten skirt panel screws. It may deform the panel. Tighten screws only enough to fully compress the lockwashers.

Referring to the supplied Feed Support Installation drawing (240159) supplied with the antenna, install the Rotating Tube Assembly at this point.

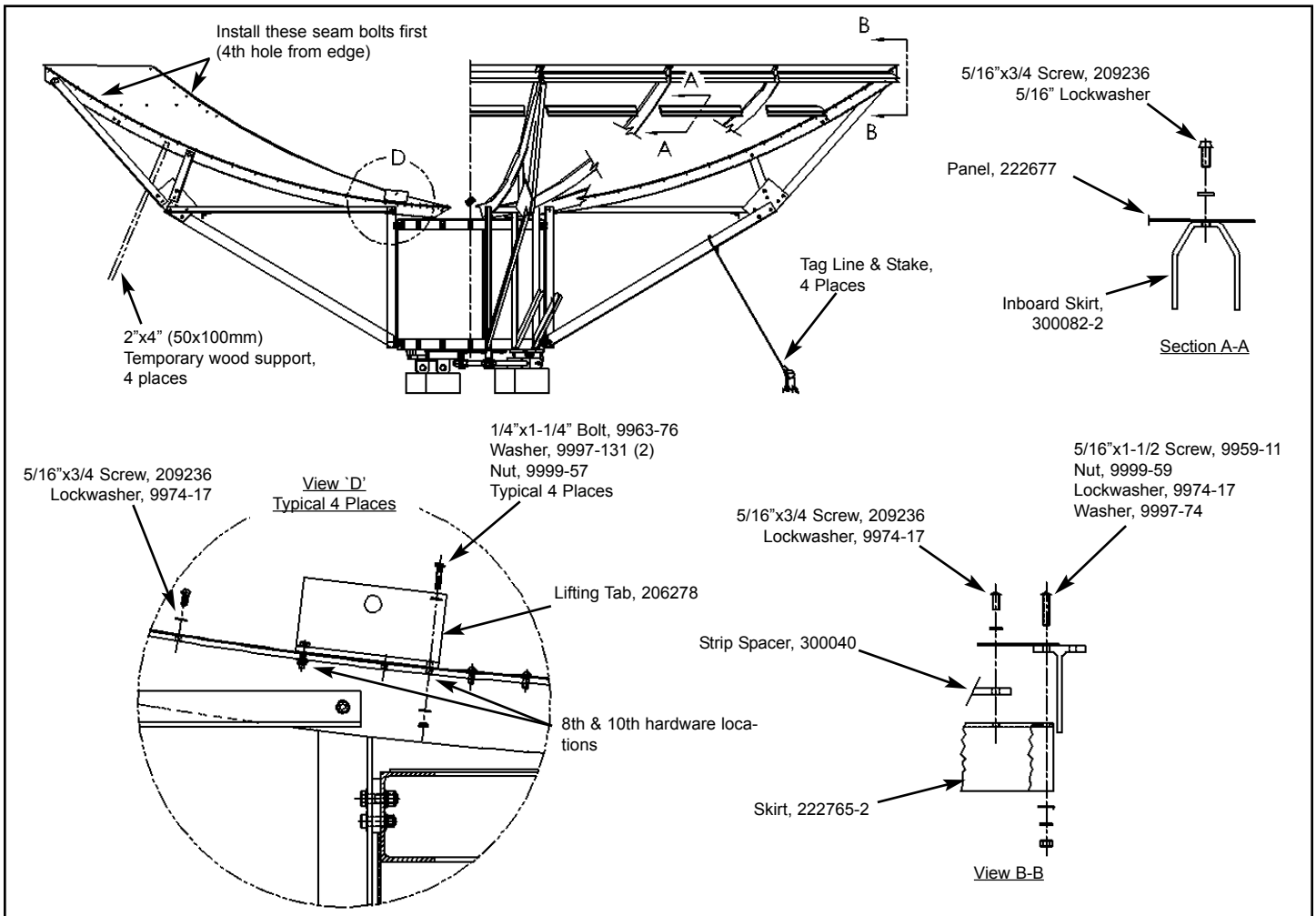

Figure 15

Step 8 Attach the reflector panels by placing them on the ribs and sliding them inward, carefully guiding the rib flange between the skirt and panel. Place seam hardware (209236 & 9974-17) in the fourth hole from the outboard edge on both sides of the panel first, finger tight only. Then place all remaining hardware, finger tight only. then attach skirt to rib hardware as shown in Figure 15, View B-B, finger tight only. Panels should be added opposite to each other to balance the enclosure assembly (first attach panel 1 and panel 2, then panel 3 and panel 4, and so on).

Step 9 Loosely attach Lifting Tabs (206278), located on the 8th and 10th seam holes of the panel. Attach 90 deg. apart from each other (refer to Fig.15, View 'D' and Figure 15A).

Step 10 Check each reflector panel fit to ensure that seam widths and panels are not overlapping. All panel seam hardware should be loose before Theodolite Installation and Calibration as outlined later in this manual.

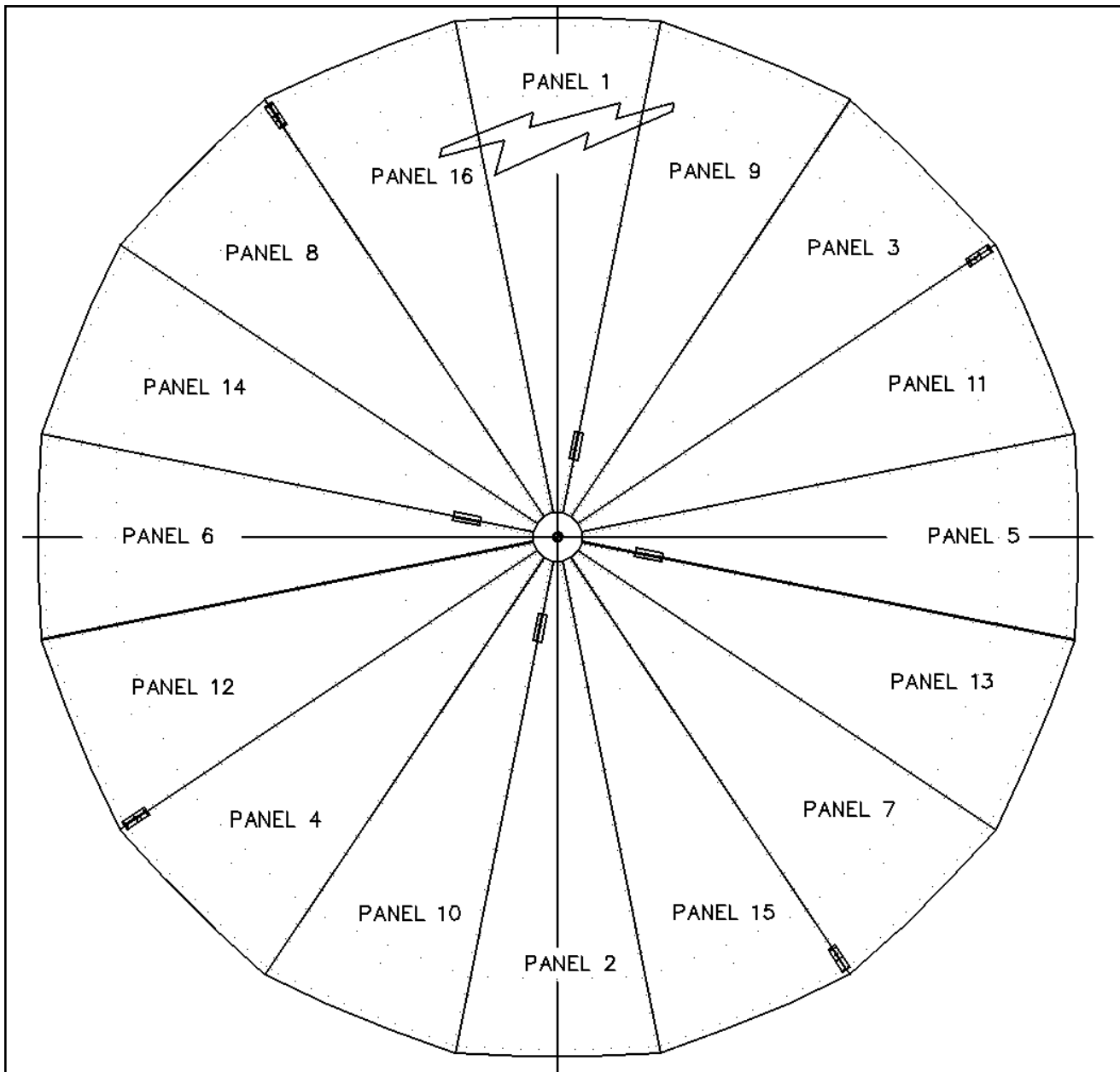

Figure 15A

Step 11 After all 16 reflector panels are fastened to ribs. Attach the Cross Struts (300078) by placing them in-between the Inner Struts (300080) and snug tight the hardware. Refer to Figure 16.

After all 16 Cross Struts are attached, tighten all hardware.

NOTE: The Cross Struts are the last item to be assembled to insure the ease of Reflector Panels to be mounted on top side of the ribs.

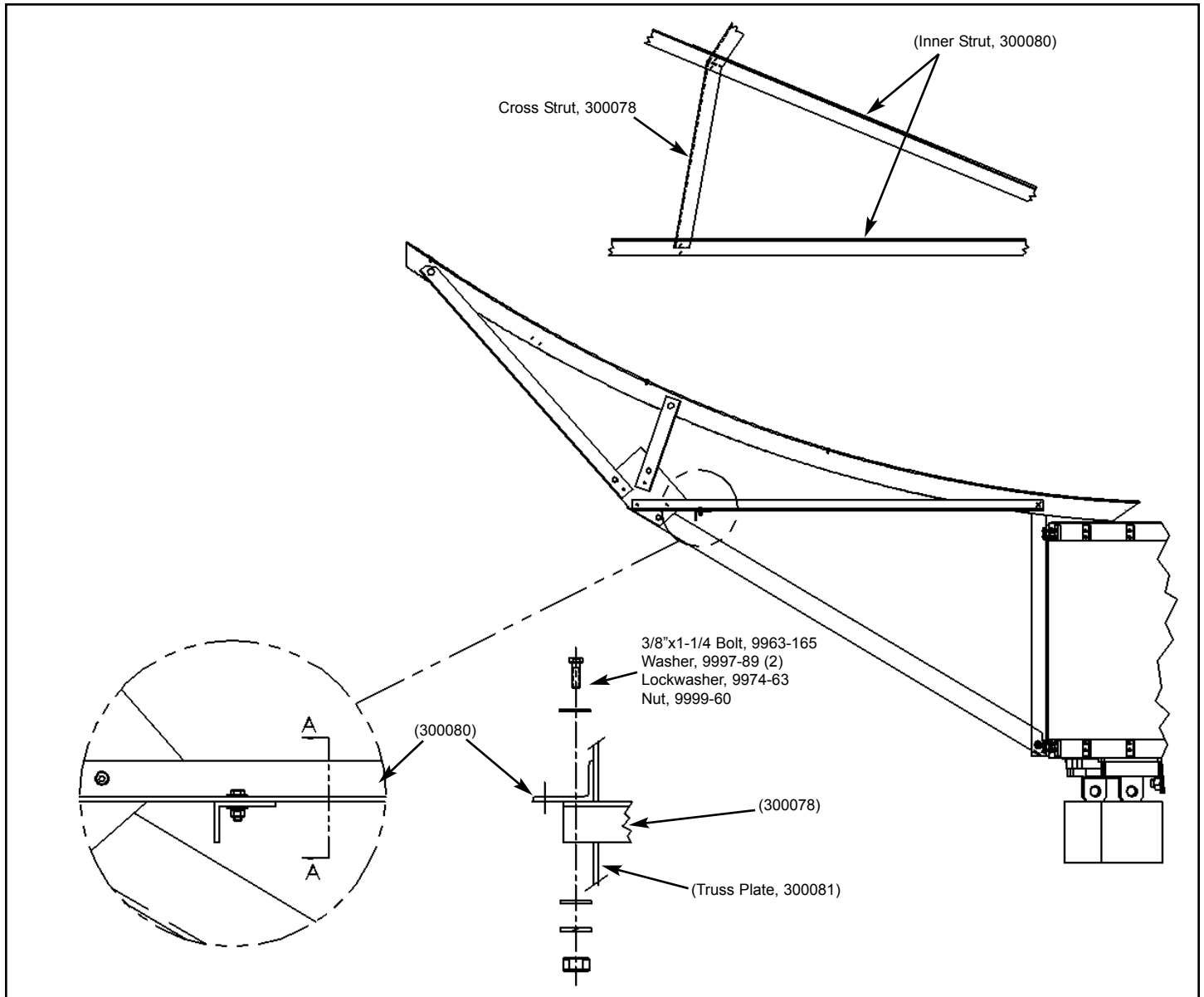

Figure 16

The Reflector/Backstructure Assembly is now complete. Refer to the next section on Reflector Alignment & Theodolite Installation.

Reflector Alignment

Notice

Temperature change during calibration or alignment of this reflector will adversely effect the alignment quality, and therefore, the performance of this antenna. Calibration and alignment should only be done during stable temperature conditions, typically after sun-set or under heavy cloud cover.

Before the theodolite installation/calibration, or reflector alignment, all panel seam hardware should be loose including the lifting tab hardware. The only exception to this is the torque tube support strut hardware and brackets, which should be tight. The subreflector struts **should not** be attached to the reflector at this time.

Theodolite Installation

During alignment, do not step on drum skin or directly on ribs. This will affect the theodolite position.

Step 1

Cut two pieces of 2x4 lumber to length and lay on top of ribs at hub tab locations. Lay plywood on top of 2x4 lumber. Refer to Figure 17.

Before installing the theodolite support kit onto the torque tube make sure to set the height of the support/theodolite assembly as shown in Figure 18. This will help in the subsequent adjustments.

Assemble theodolite support kit on top of torque tube as shown in Figures 18 and 19.

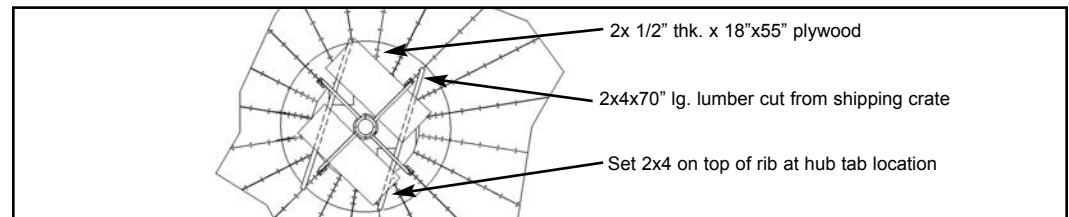

Figure 17

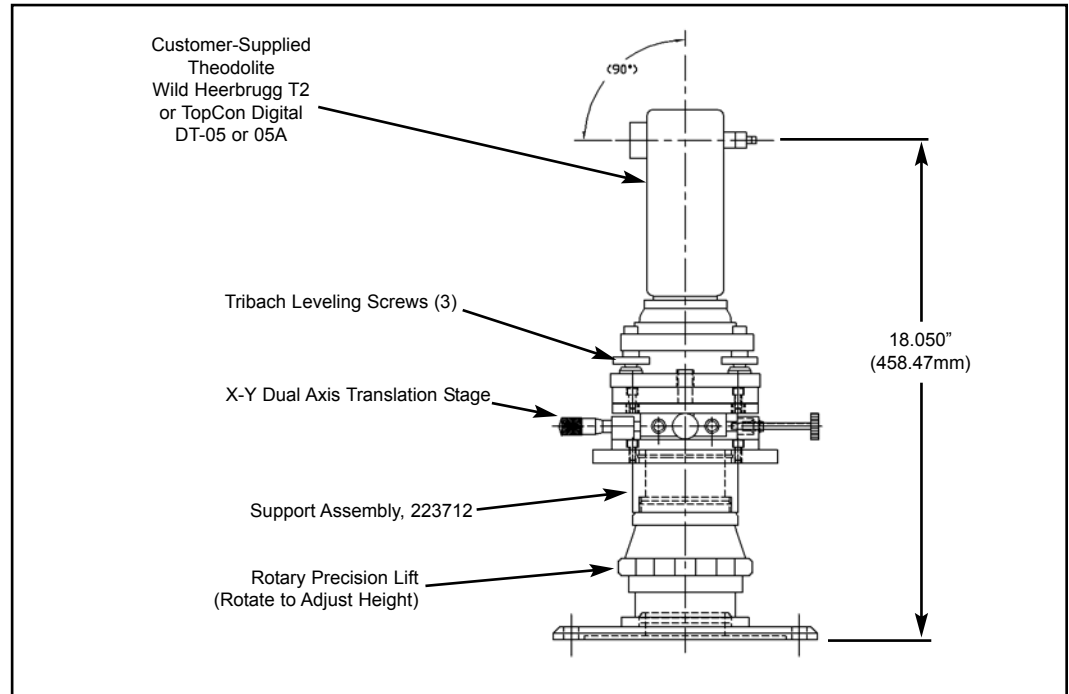

Figure 18

1.2 Assemble Alignment Stick:

The alignment stick comes in three sections. Screw the sections together, matching the letters on the ends of the individual sections.

1.3 Install Brass Rod Holders:

Install brass rod holders in seam hole #11 on rib #2, 7, & 10 in Figures 19 and 20. Reflector seam screws must first be removed in these locations. Make sure the bottom of the rod holders are sitting flush on the reflector panels and they are pointed toward the theodolite assembly.

Attach the alignment stick to the rod holder in rib #2 with the knob assembly.

1.4 Install Target Screws:

Install target screws in all 16 ribs as shown in Figure 19 (reflector seam screws must first be removed in these locations). Be sure that target screws are fully seated on the rib surface, not the reflector surface. This is best done during assembly of Reflector/Backstructure.

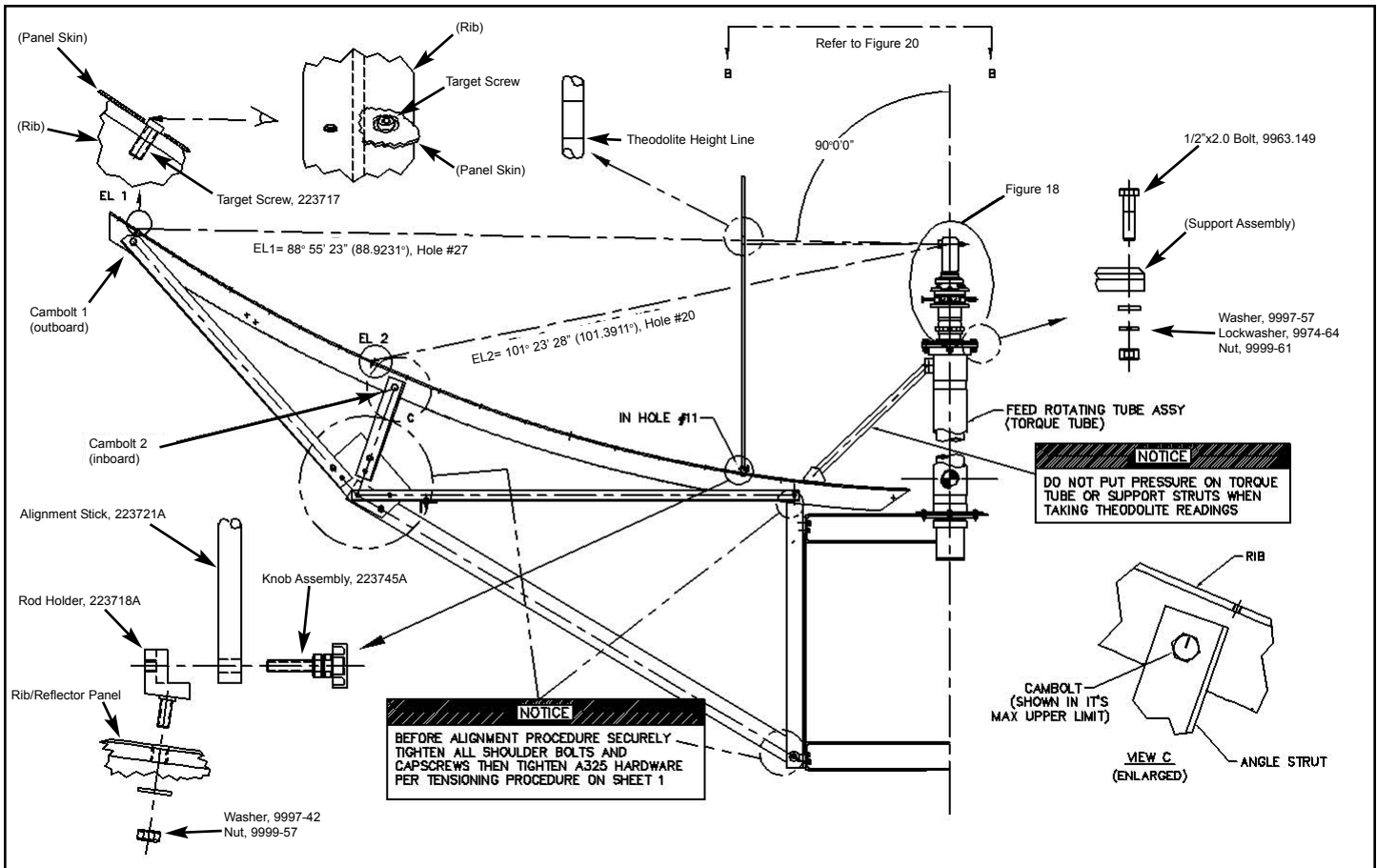

Figure 19

1.5 "Clock" the Theodolite Assembly:

Refer to Figure 20. The theodolite support assembly must be 'clocked' to the brass rod holders such that two of the tribrach leveling screws run parallel with ribs 2 and 10 (see enlarged view in Figure 20). This can be accomplished by rotating the top flange of the torque tube which will rotate the entire theodolite assembly.

Step 2

Calibration:

Note: Before adjustments, make sure that all the hardware connecting the torque tube to the reflector are fully tightened. Any loose hardware will cause improper theodolite alignment.

2.1 Calibration Sequences:

- 1) Leveling (sect. 2.2)
- 2) Centering (sect. 2.3)
- 3) Adjust Height (sect. 2.4)
- 4) Repeat 1-3 as necessary (typical 4-5 times) to achieve calibration specifications.
- 5) Ready for reflector alignment.

2.2 Leveling:

After installation onto the torque tube, it is necessary to level the theodolite to the reflector. This can be accomplished by adjusting two of the three leveling screws of the tribrach.

With the stick at rib #2, focus and adjust the theodolite elevation to the scribe line and record this reading as R1.

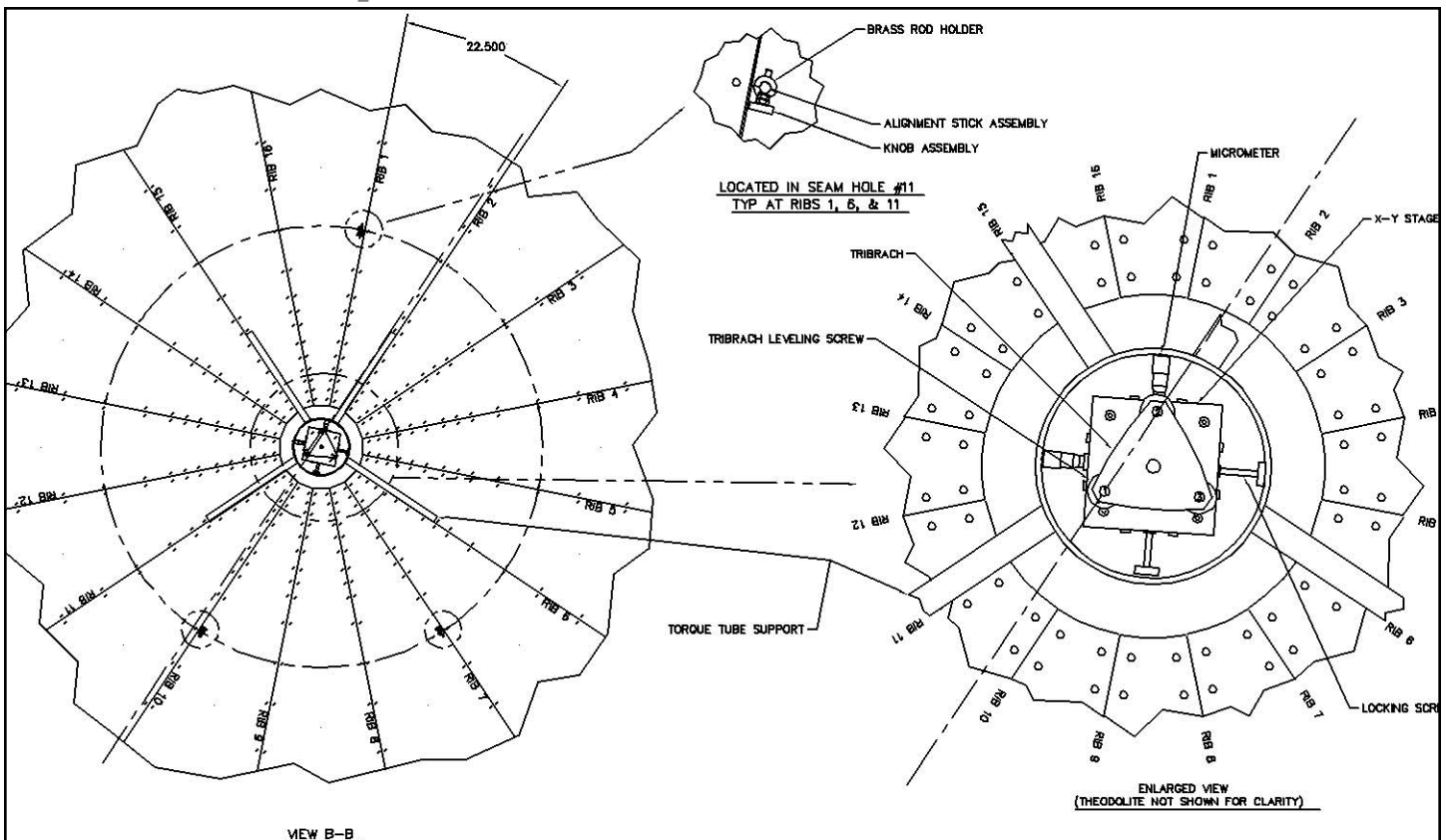

Figure 20

Relocate stick to rib #7. Rotate theodolite, focus and adjust elevation to the scribe line and record this reading as R2.

Relocate stick to rib #10. Rotate theodolite, focus and adjust elevation to the scribe line and record this reading as R3.

Calculate an average angle by adding R1, R2, & R3 together and dividing by 3. Record this as R4.

Adjust theodolite elevation angle to this new angle R4.

Adjust the tribrach leveling screw #1 (nearest the alignment stick, which should be in rib #10, see Figure 20) up or down until the theodolite is sighted on the scribe line. (Do not move leveling screws #2 or #3).

Relocate the stick to rib #7. While leaving the theodolite elevation set to R4, adjust the tribrach leveling screw #3 (nearest the alignment stick, which should be rib #7) up or down until the theodolite is sighted on the scribe line (do not move leveling screws #1 or #2).

Record the current elevation (R4) angle as R2. Relocate the stick to ribs #2 and #10, sight the scribe line, adjust and record angles R1 & R3 again.

At the end of the initial leveling procedure, angles R1, R2 & R3 should be within 1 to 2 minutes (0.02 - 0.04 deg.) of each other. This is acceptable at this stage only. Further fine leveling will be done during successive sequences. Refer to the calibration specifications shown in Figure 21 for final leveling requirements.

After leveling, adjust the centering as indicated below.

2.3 Centering:

Centering of the theodolite is accomplished with the x-y dual axis translation stage (refer to Figure 18). This device has 2 sets of micrometers and 2 sets of locking screws opposed at 90 degrees. During initial adjustment make sure that the locking screws are unscrewed counterclockwise to provide free movement of the device. The screws will be used to lock the device in place after the centering is complete.

Centering is accomplished by focusing to the bottom of 4 opposed threaded rib holes (not panel holes). Remove the seam screws from seam hole #12 at the 4 ribs which best line up with the x-y translation stage axis. This alignment may be different for every installation depending assembly variances in the support assembly. In the case of the enlarged view in Figure 20, rib #1, 5, 9, & 13 would be selected.

Focus and adjust the theodolite elevation until the bottom edge of a threaded rib hole is sighted. Record this reading as T1. Repeat this procedure 180 degrees apart and record the new reading as T2. Add T1 and T2 and divide by 2. Record this number as T3. Adjust the elevation axis angle of the theodolite to T3. Using the micrometer adjustment of the X-Y translation stage that is aligned with these two sightings. Adjust until the theodolite cross hair is focused to the hole edge.

Rotate the theodolite 180 degrees and resight. For initial centerings, this should be within 1 to 2 minutes (0.02 to 0.04 deg.) of T3. This is acceptable at this stage only. Further fine centering will be done during successive sequences.

7.6M FINAL ALIGNMENT DATA			THEODOLITE CALIBRATION SPECIFICATIONS													
SITE: _____			<table border="1" style="width: 100%; border-collapse: collapse;"> <tr> <td style="width: 20%;">LEVELING:</td> <td>ALL 3 STICK POSITION READINGS WITHIN 15" (0.0042 ') OF EACH OTHER.</td> </tr> <tr> <td>CENTERING:</td> <td>ALL 4 CENTER READINGS WITHIN 25' (0.0069') OF EACH OTHER.</td> </tr> <tr> <td>HEIGHT:</td> <td>ALL 3 LEVEL POSITION READINGS WITHIN 15" (0.0042 ') OF 90°00'00".</td> </tr> </table>		LEVELING:	ALL 3 STICK POSITION READINGS WITHIN 15" (0.0042 ') OF EACH OTHER.	CENTERING:	ALL 4 CENTER READINGS WITHIN 25' (0.0069') OF EACH OTHER.	HEIGHT:	ALL 3 LEVEL POSITION READINGS WITHIN 15" (0.0042 ') OF 90°00'00".						
LEVELING:	ALL 3 STICK POSITION READINGS WITHIN 15" (0.0042 ') OF EACH OTHER.															
CENTERING:	ALL 4 CENTER READINGS WITHIN 25' (0.0069') OF EACH OTHER.															
HEIGHT:	ALL 3 LEVEL POSITION READINGS WITHIN 15" (0.0042 ') OF 90°00'00".															
INSTALLER: _____																
DATE: _____																
	OUTBOARD (EL1) TARGET ANGLE	INBOARD (EL2) TARGET ANGLE	<table border="1" style="width: 100%; border-collapse: collapse;"> <thead> <tr> <th colspan="3" style="text-align: center;">REFLECTOR ALIGNMENT ANGLE SPECIFICATIONS</th> </tr> <tr> <th></th> <th style="text-align: center;">FOR TOPCON THEODOLITE</th> <th style="text-align: center;">FOR WILD THEODOLITE</th> </tr> </thead> <tbody> <tr> <td>EL 1</td> <td style="text-align: center;">88° 55' 23"</td> <td style="text-align: center;">89° 12' 58"</td> </tr> <tr> <td>EL 2</td> <td style="text-align: center;">101° 23' 28"</td> <td style="text-align: center;">101° 47' 17"</td> </tr> </tbody> </table>		REFLECTOR ALIGNMENT ANGLE SPECIFICATIONS				FOR TOPCON THEODOLITE	FOR WILD THEODOLITE	EL 1	88° 55' 23"	89° 12' 58"	EL 2	101° 23' 28"	101° 47' 17"
REFLECTOR ALIGNMENT ANGLE SPECIFICATIONS																
	FOR TOPCON THEODOLITE	FOR WILD THEODOLITE														
EL 1	88° 55' 23"	89° 12' 58"														
EL 2	101° 23' 28"	101° 47' 17"														
RIB 1																
RIB 2																
RIB 3																
RIB 4																
RIB 5																
RIB 6																
RIB 7																
RIB 8																
RIB 9																
RIB 10																
RIB 11																
RIB 12																
RIB 13																
RIB 14																
RIB 15																
RIB 16																

Figure 21

Repeat the above procedure for the other axis of the X-Y translation stage 90 degrees to the first one.

After centering, adjust the theodolite height as indicated below.

2.4 Adjust Height:

The height adjustment of the theodolite is accomplished with the precision lift (refer to Figure 18). This device can lower or raise the theodolite to the desired height by rotating the large rim located at the center of the upper body of the device. Ensure torque tube does not rotate when adjusting precision lift.

After the leveling and centering is accomplished, the theodolite must be adjusted to be in line with the scribe line of the alignment stick.

With the stick located at rib #10, first adjust the elevation angle of the theodolite to exactly 90 degrees 00 minutes and 00 seconds. Then, while the theodolite is set to this angle, focus to the scribe line and make any up or down adjustment with the lift. Record this as H1 (90 degrees).

Relocate the stick to rib #2. Focus and adjust the elevation to align to stick scribe line, record as H2.

Relocate the stick to rib #7. Focus and adjust the elevation to align to stick scribe line. Reord as H3.

The specification for height requires that H1, H2 & H3 be within +/-15 seconds (0.0042 degrees) of 90 degrees. This can only be achieved through successive leveling/centering sequences.

Step 3

Repeat as Necessary:

Repeat 2.2, 2.3, and 2.4 until the calibration specifications are achieved. Each successive loop through these procedures should produce smaller deviations from the specifications until they are finally achieved.

After all calibration specifications are achieved, gently tighten the X-Y stage locking screws.

Reflector Alignment

1. Introduction:

The reflector consists of 16 panels supported by 16 ribs. Each rib is supported and set in place by a truss assembly. Each truss assembly has two cambolt adjustments which are used with the theodolite to position the ribs in their theoretical location.

Note:

Complete and proper installation and calibration of the theodolite assembly is required before proceeding with reflector alignment.

2. Pre-Adjustment Procedure:

2.1. After the antenna assembly, make sure that all the inboard and outboard cambolts are set to their maximum upper limit. This is accomplished by turning the cambolt until the mark on head of the hex bolt is pointing toward the rib, along the axis of the angle strut (see Figure 19, View `C').

2.2. Make sure that the nuts retaining the cambolts are not too loose. As a rule of thumb, tighten the cambolt nut until tight and undo 1/4 turn until the cambolt turns freely but not totally loose.

2.3. Before starting alignment, make sure that all the noted hardware associated with the truss assembly is fully tightened. Refer to Figure 19.

2.4 If not yet done, install special target screws at all locations as indicated in Figure 19). Ensure that the screw is fully seated on the rib surface. This is best done during reflector assembly.

2.5. Do not put pressure on the torque tube or support struts when sighting through the theodolite.

3.0 Rib Alignment (Refer to Figure 19):

3.1 The adjustment sequence of the ribs must be followed in order to achieve proper alignment. Deviation from the described sequences and procedures will result in more difficult alignment of the ribs and may even result in an incorrect adjustment of the reflector itself.

3.2 Refer to Figure 19. Each rib has two target screws which will be used for panel adjustment. One target screw is located near the outboard cambolt location at seam hole #27. The other target screw is located near the inboard cambolt location at seam hole #20.

3.3 Rough Outboard Alignment:

Adjust theodolite elevation angle to the 'EL1' value indicated in Figure 19. Point and focus the scope of the theodolite to target EL1 (do not move elevation) located on the rib #1, which is to the right of the top panel (top center of antenna with Andrew 'Flash' logo). While still focusing to the target, have the outboard cambolt slowly rotated until the upper edge of the target screw is within +/-15 seconds (0.0042 deg.) of the theodolite crosshair.

Do not tighten any hardware at this time.

3.3.1 Repeat the procedure described in 3.3 for all 16 outboard target screws at location EL1.

3.3.2 Travel around the reflector 2 or 3 times repeating all 16 adjustments, or until all 16 targets remain on EL1 within +/-15 seconds. Some target screws may not reach EL1, or may move while other ones are being adjusted. Repeating the adjustment around the reflector 2 or 3 times should solve this.

3.4 Rough Inboard Alignment:

Adjust theodolite elevation angle to the 'EL2' value indicated in Figure 19. Point and focus the scope of the theodolite to target EL2 (do not move elevation) located on the rib #1. While still focusing to the target, have the inboard cambolt slowly rotated until the upper edge of the target screw is within +/-15 seconds (0.0042 deg.) of the theodolite crosshair.

Do not tighten any hardware at this time.

3.4.1 Repeat the procedure described in 3.4 for all 16 inboard target screws at location EL2.

3.4.2 Travel around the reflector 2 or 3 times repeating all 16 adjustments, or until all 16 targets remain on EL1 within +/-15 seconds. Some target screws may not reach EL, or may move while other ones are being adjusted. Repeating the adjustment around the reflector 2 or 3 times should solve this.

3.5 Fine Outboard Alignment:

NOTE:

Tightening of seam hardware near the outer rim during 'Fine Outboard Alignment' must be done from a ladder outside the reflector. Do not put any weight or exert any force on the reflector while tightening the outer seam hardware.

Again, adjust theodolite elevation angle to the EL1 value. Point and focus the theodolite again to target EL1 located on rib #1. While still focusing to the target, have the outboard cambolt slowly rotated until the upper edge of the target screw is again within +/-15 sec. (0.0042 deg.) of the theodolite crosshair.

After each individual adjustment, semi-tighten (compressed lockwasher) seam hardware #26 and #27 (3rd and 2nd from the rim) on the rib being adjusted.

3.5.1 Repeat the procedure described in 3.5 for all 16 outboard target screws at location EL1.

3.5.2 Repeat all 16 adjustments again. This time, after each individual adjustment, fully tighten the cambolt nut, as well as seam hardware #26, 27 and 28 (#28 is the outermost on the seam) on the rib being adjusted.

3.5.3 Repeat all 16 adjustments again. This time, after each individual adjustment, fully tighten seam hardware #24 and 25 on the rib being adjusted.

The outer ring of the reflector is now 'locked' in place.

3.6 Fine Inboard Alignment:

NOTE:

During seam hardware tightening as described in 'Fine Inboard Alignment' take extra precaution not to step on the center of the panels as your weight will displace the panel during tightening. Try to step on the directly on the rib/panel connection near the seam hardware.

Adjust theodolite elevation angle to the EL2 value. Point and focus the theodolite to target EL2 located on rib #1. While still focusing to the target, have the inboard cambolt slowly rotated until the upper edge of the target screw is again within +/-15 sec. (0.0042 deg.) of the theodolite crosshair.

After each individual adjustment, semi-tighten the cambolt nut on the rib being adjusted.

3.6.1 Repeat the procedure described in 3.6 for all 16 inboard target screws at location EL2.

3.6.2 Repeat all 16 adjustments again. This time, after each individual adjustment, fully tighten the cambolt nut on the rib being adjusted.

3.6.3 Repeat all 16 adjustments again. This time, after each individual adjustment, fully tighten seam hardware #23, 22, 21, 20, 19 & 18 on the rib being adjusted.

The inner ring of the reflector is now 'locked' in place.

3.6.4 Repeat all 16 adjustments again at EL2. This time, after each adjustment, fully tighten seam hardware #17, 16, 15 & 14 on the rib being adjusted.

3.6.5 Repeat all 16 adjustments again at EL2. This time, after each individual adjustment, fully tighten remaining seam hardware (#1 through #13) on the rib being adjusted.

4.0 Data Recording:

After all seam hardware is tight. Re-sight all 16 outboard and all 16 inboard targets and record their actual final elevation angles. Use the data table provided in Figure 21. If necessary, this data will be useful for further analysis.

5.0 Theodolite Removal

Remove theodolite assembly from torque tube and properly place components in the case. Remove all target screws and replace them with proper seam hardware. Remove all rod holders and replace them with proper seam hardware. Remove temporary platform.

The reflector is now ready to accept the subreflector struts and be lifted onto the mount.

Reflector to Ground Mount Assembly

Step 1

Attach 16ft. (5m) chokers with corresponding 5/8" shackles to the Lifting Tabs (206278). Attach 30ft. (9m) tag lines of suitable rope equally spaced about reflector (refer to Figure 22).

Note: Ensure ground mount pedestal assembly has elevation jack in the fully retracted position.

Carefully raise the reflector assembly, position it over the pedestal and gently lower the assembly onto the pedestal. Attach and tighten using indicated hardware in Figure 22.

Note: After attaching the reflector, the crane may now be removed while the antenna is in the zenith position.

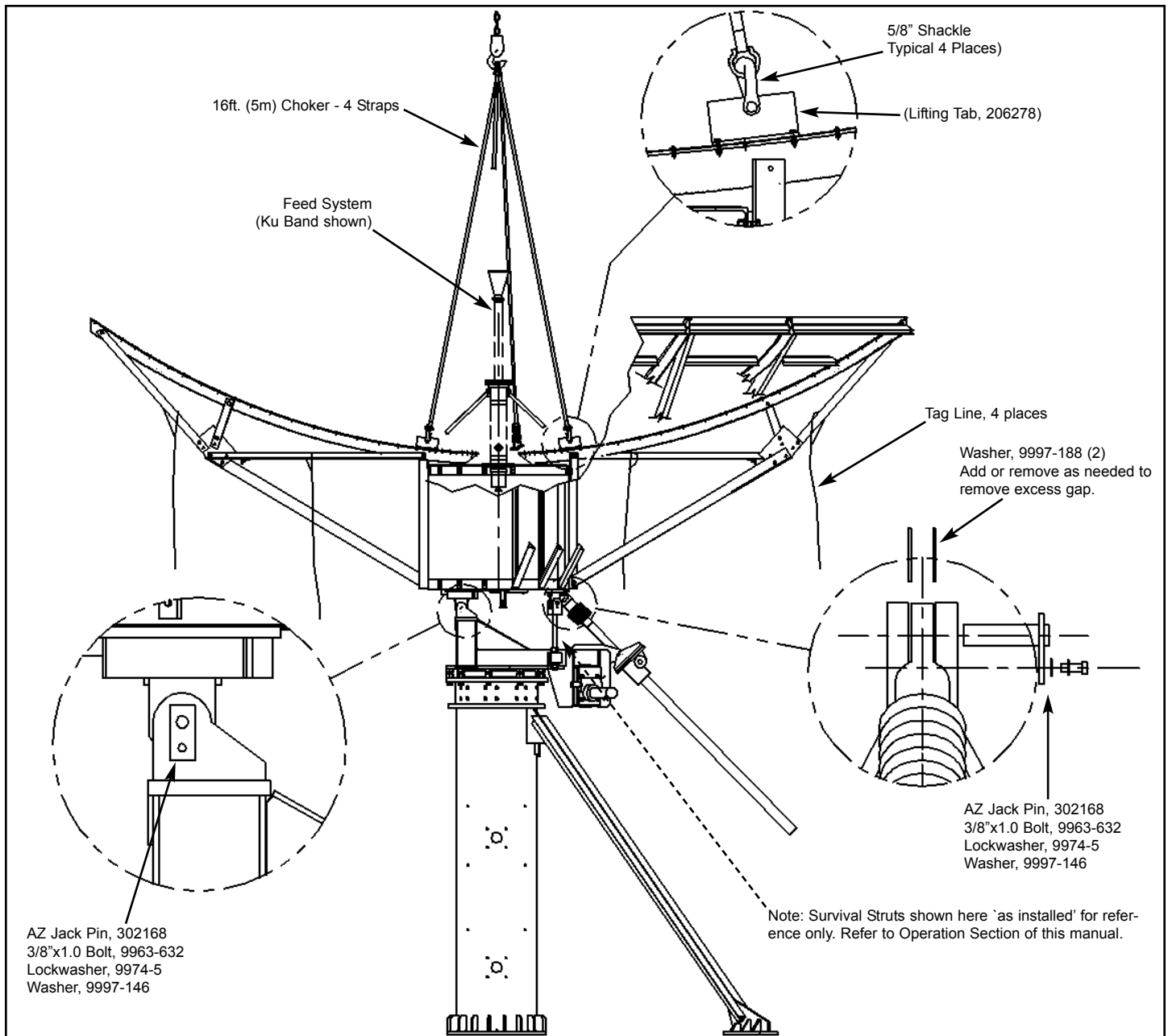

Figure 22

Subreflector Installation

NOTE:

Ensure that the Feed System is installed prior to installation of Subreflector and Struts.

Step 1

Place the reflector in the zenith (EL = 90 deg.) position.

Step 2

Refer to Figure 23. Loosely assemble Subreflector Strut Assembly (300092) as shown using supplied Angles (300088), Subreflector Strut Brackets (300090) and corresponding mounting hardware.

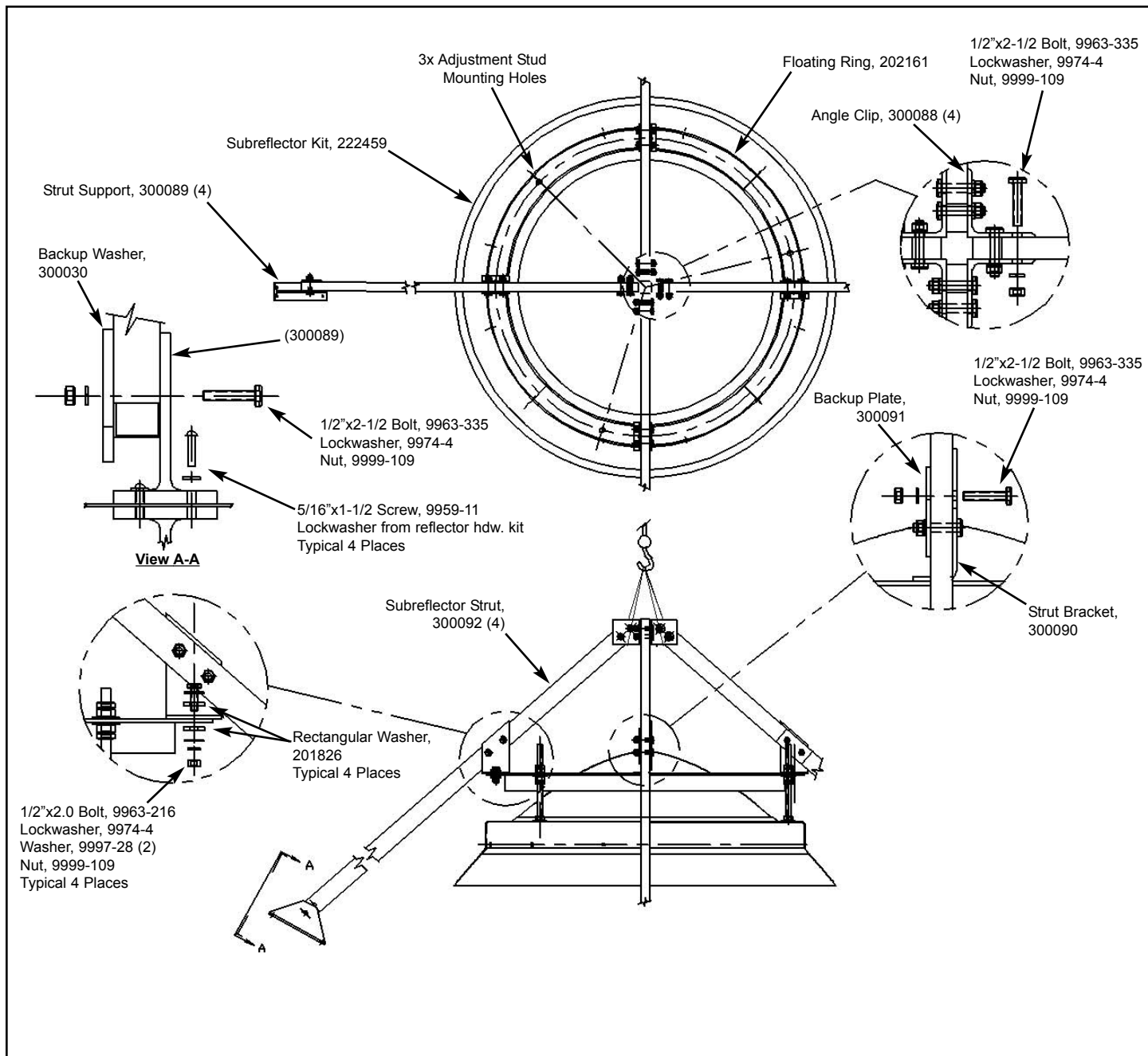

Figure 23

Step 3 Refer to Figure 23, View A-A and Figure 24. Loosely attach Subreflector Strut Supports (300089) to panel segments 8-16, 3-11, 7-15 and 4-12 as shown. Replace screws, washers, lockwashers and nuts previously installed during reflector assembly.

NOTE:

Step 4 Subreflector Strut Supports should be positioned according to Step 3 and at the 2nd and 3rd seam holes from the outboard end of the rib. Refer to Figure 25.

Position and loosely attach pre-assembled Subreflector/Floating Ring assembly to corresponding mounting holes in Subreflector Strut Brackets as shown in Figure 23 using supplied bolts, rectangular washers, lockwashers and nuts. Attach temporary nylon slings, being careful not to damage subreflector assembly.

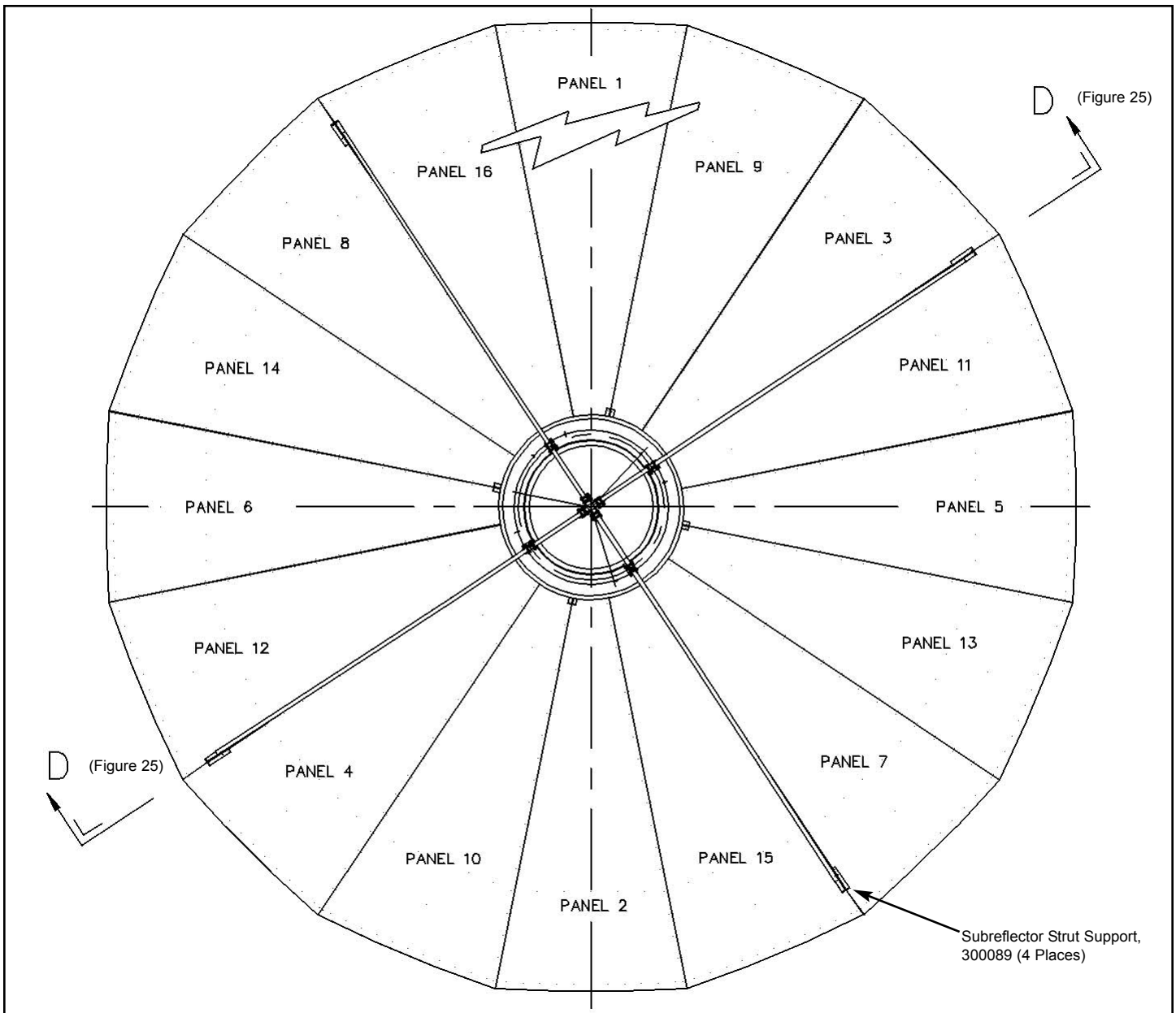

Figure 24

Step 5 Carefully raise and attach pre-assembled subreflector/strut assembly to corresponding subreflector strut supports as shown in View A-A (Figure 23) and Figure 25 using supplied hardware.

Step 6 Securely tighten all subreflector/strut assembly mounting hardware except for floating ring hardware shown in Figure 25. Remove temporary nylon slings.

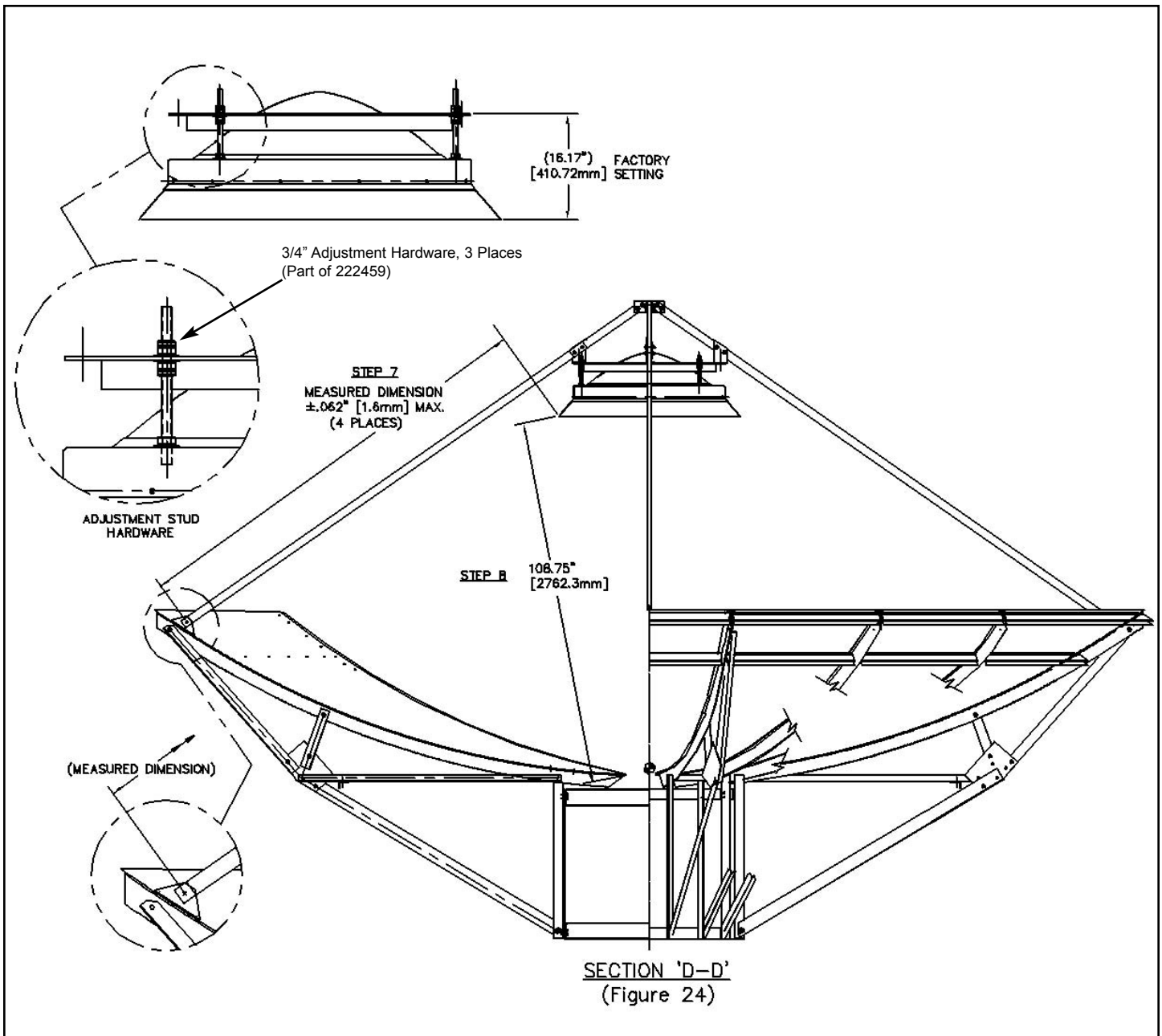

Figure 25

Subreflector Centering

Step 7

Measure and note the distance between outermost subreflector strut support bolt head and the subreflector rim as shown in Figure 25. Obtain corresponding measurements from remaining subreflector struts. These measurements should have a maximum differential of 0.062 in. (1.5mm). If adjustment is necessary, loosen the four floating ring bolts and slide subreflector appropriately to achieve the 0.062 in. (1.5mm) differential. Make sure to re-tighten bolts when finished.

Subreflector Focusing

Step 8

Refer to Figure 25. Use measuring tape to set indicated dimension between bottom edge of panel and subreflector aperture rim at the three subreflector adjustment stud locations. Use subreflector adjustment stud hardware to achieve equal axial dimension of 108.75 in. (2762.3mm) at all three locations. Securely tighten adjustment hardware.

Step 9

Repeat procedure described in Step 7. If any dimensional variation is found, repeat adjustment procedure described in Step 7 then repeat procedure in Step 8 if required.

Operation

Overview

After you have completed the assembly of your antenna, you are now ready to become operational. In order to operate the earth station antenna, you will need to direct it to the desired satellite adjusting both the elevation and azimuth angles appropriately. The following procedures provide details on how to correctly position your antenna on the desired satellite.

Acquiring A Satellite

There are several procedures that may be used to properly acquire a satellite. Andrew recommends that a spectrum analyzer be used. The following procedures provide explanation as to how to use the spectrum analyzer.

While viewing the spectrum analyzer screen, a pure noise signal as shown in Figure 4-1 will probably be observed. Additionally, some transponder signals may be observed above the noise signal as shown in Figure 4-2.

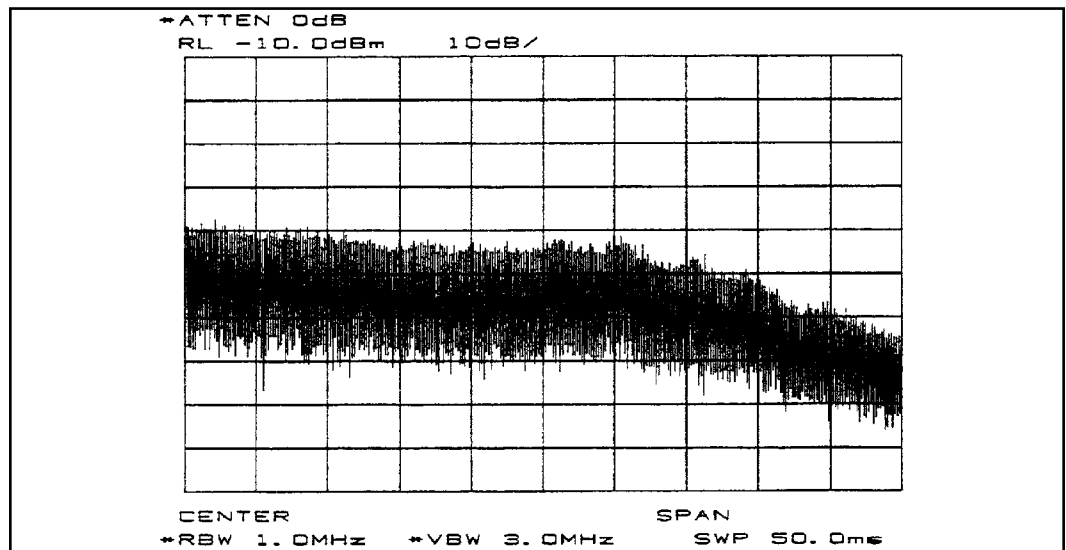

Figure 4-1: Pure Noise Signal on Spectrum Analyzer

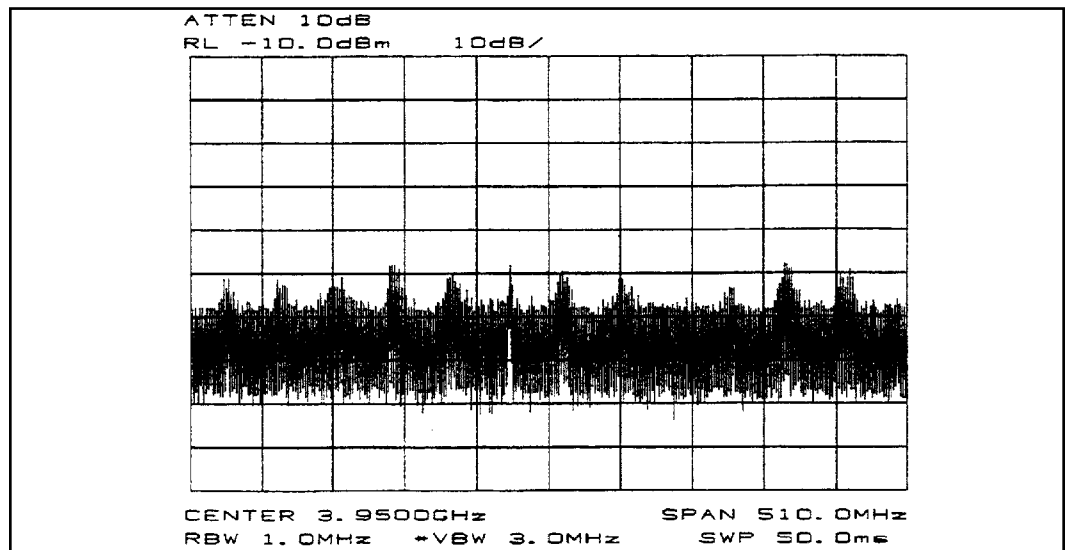

Figure 4-2: Minimum transponder Signal on Spectrum Analyzer

The following steps provide the procedure for acquiring a satellite.

Step 1

Manually move the antenna in the azimuth (scanning back-and-forth) to achieve the maximum (greatest amplitude) transponder signals.

- Scan in one direction until the amplitude continues to diminish and then scan in the opposite direction until the same condition occurs.
- Return to the position yielding the greatest amplitude.

The maximum azimuth excursion from the original setting should not exceed plus or minus 1.5 degrees or the antenna may begin to access a different satellite.

Step 2

With the antenna positioned in azimuth such that the transponder signals are maximized, follow the same procedure manually moving the antenna in elevation (scanning up-and-down) to further maximize the transponder signals.

Step 3

Repeat this procedure alternating between the azimuth and elevation excursions of the antenna to peak the transponder signal amplitude.

A transponder signal amplitude of 30 dB or greater from peak to average noise signal indicates the antenna is receiving the signal on the main beam. A transponder signal amplitude less than 30 dB or greater indicates the antenna is receiving the signal on a side lobe of the main beam.

Step 4

With the antenna peaked on a side lobe in azimuth and/or elevation, move the antenna in azimuth while observing the spectrum analyzer screen as shown in Figure 4-3.

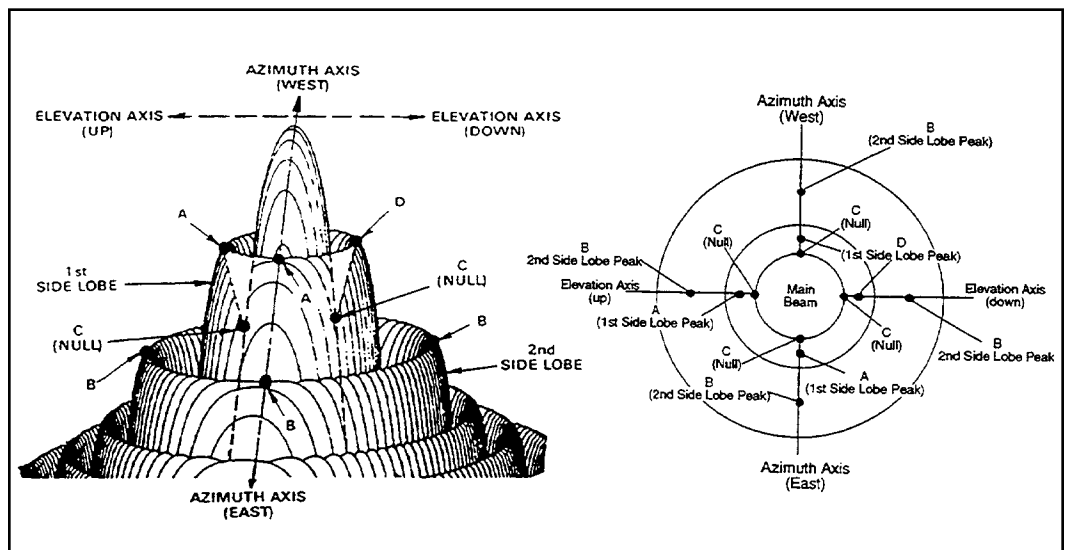

Figure 4-3: Antenna Radiation Pattern Topographical Diagram with Plan View

Step 5

If the signal amplitude diminishes and does not increase (position B) to the level noted when the antenna was peaked on the side lobe, the antenna is moving away from the main beam; reverse the direction of the antenna movement.

From the original side lobe position (position A), the signal amplitude should now diminish to a null point at position C (minimum amplitude showing only signal noise) and then symmetrically increase again to the same level at position D as noted at position A. At the null point (position C), the antenna is aligned with the alternate (elevation) axis. If the antenna was peaked on a side lobe in azimuth, it was appropriately aligned with the elevation axis; proceed with step 6. If the antenna was peaked on a side lobe in elevation, it was appropriately aligned with the azimuth axis; proceed with step 6 moving the antenna in azimuth rather than elevation.

Step 6

Move the antenna in elevation while observing the spectrum analyzer screen. If the signal amplitude increases, decreases and then increases again but to a lesser value, the antenna is moving in the wrong direction; reverse the direction of the antenna movement. From the original null point, the signal level should increase and decrease alternately, but with increasing amplitude until the transponder signal increases to a level of at least 30 dB at which time the main beam. Continue to manually peak the signal to a maximum level using the azimuth and elevation adjustments.

Step 7

If the antenna is aligned in azimuth and elevation (signal maximized) and 24 transponder signals (12 horizontal and 12 vertical) are noted, the polarization adjustment is set incorrectly and must be modified. If 12 transponder signals are noted, they may or may not be the properly polarized signals. Therefore 24 transponder signals must be visually noted in order to determine the proper polarization setting.

Step 8

Rotate the feed assembly clockwise until 24 transponder signals are noted and of approximately equal amplitude.

NOTE: It is more accurate and visually easier to minimize the alternate set of transponder signals rather than maximizing the transponder of interest.

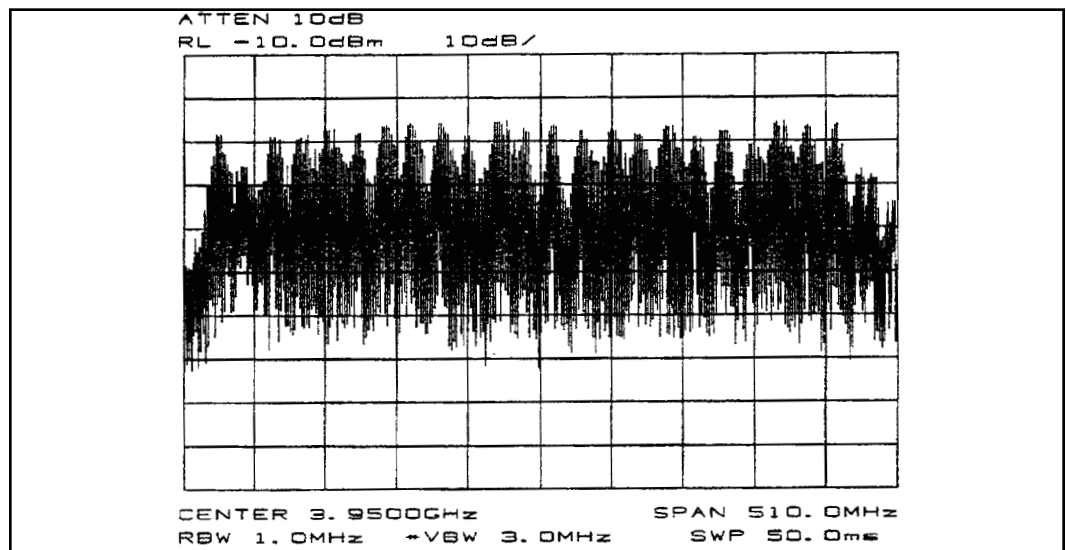

Figure 4-4: Polarization at 45 degrees from Optimum Setting

Step 9

With all 24 transponder signals of approximately equal amplitude appearing on the spectrum analyzer screen determine the specific antenna system and satellite parameters. Rotate the feed assembly as required until the appropriate (odd or even) transponder signals are maximized.

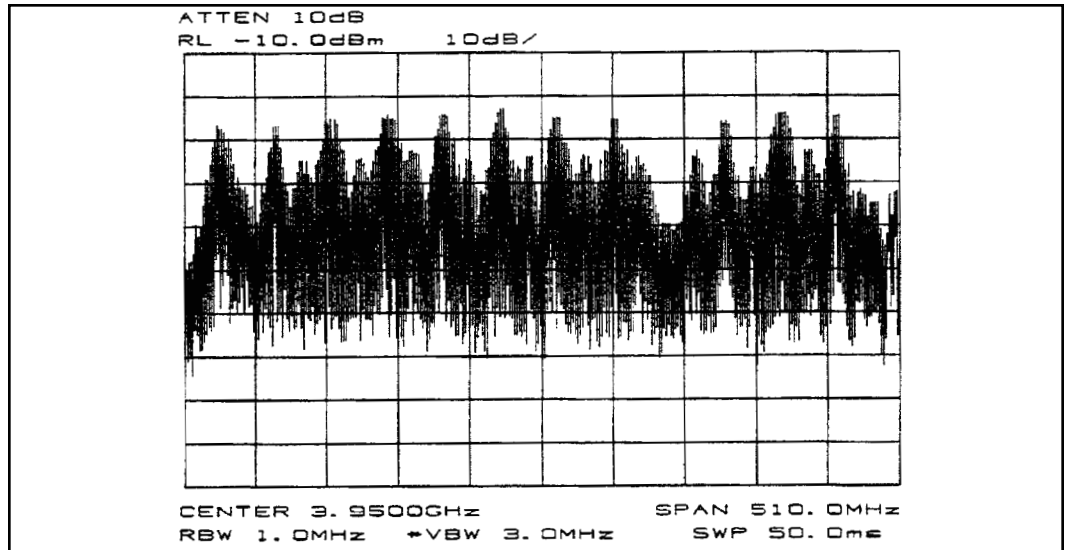

Figure 4-5: Maximizing Odd Transponders

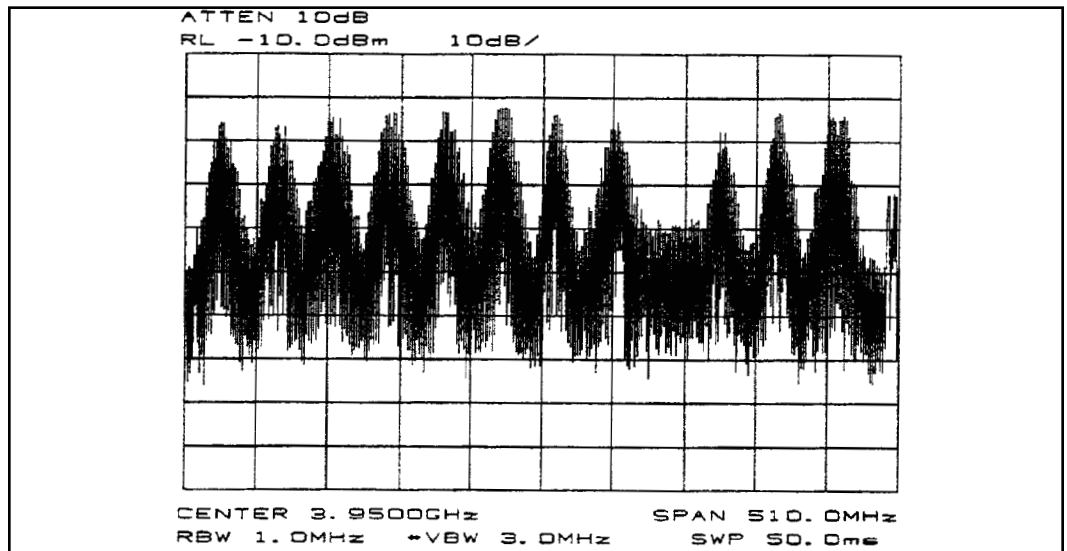

Figure 4-6: Optimum Polarization Setting

Subreflector Adjustment

After the satellite has been acquired and testing has taken place with the spectrum analyzer, the subreflector may need to be adjusted to maximize optimum performance of your antenna. The following procedures should be followed if a subreflector adjustment is required to maximize optimum performance.

NOTE: All INTELSAT Type Approved antennas do not require subreflector adjustment.

Before proceeding, azimuth and elevation patterns should be conducted to determine the adjustments that need to be made. The goal is to achieve a high peak on the main lobe and even distances between the main lobe and sidelobes as shown in Figure 4-6.

NOTE: No adjustments should be made in the receive band.

If your pattern dictates a need to adjust the azimuth angle(the left sidelobe requires adjustment), the west side of the subreflector should be adjusted outward by loosening the screws on the subreflector and adjusting the left side outward. An easy way to remember this adjustment feature is through the acronym WOLD (West Out Left Down).

If your pattern dictates a need to adjust the elevation angle(the right sidelobe requires adjustment), the bottom side of the subreflector should be adjusted downward by loosening the screws between the subreflector and the struts and adjusting the bottom side of the subreflector downward. An easy way to remember this adjustment is through the acronym BOLD (Bold Out Left Down).

Each of these adjustments should be repeated until each sidelobe is of equal distance from the peak of the mainlobe.

After the BOLD and WOLD adjustments have been made, it may be necessary to adjust the main lobe. The goal is to achieve a high null depth (distance between lower intersection of sidelobes and top of main lobe) as shown in Figure 4-6.

In order to adjust the main lobe pattern characteristics **ALL** subreflector adjustment screws should be adjusted at the same degree (Note: Because the azimuth and elevation adjustments have been set, it is very important that the null depth adjustment be carefully conducted. Be careful not to alter any previous adjustments that have been made to the subreflector. Follow the procedure listed below when adjusting the null depth of the main lobe.

C-band feeds - Adjustment screws are 3/4 X 10. Move 1 turn per 1dB of imbalance.

Ku-band feeds - Adjustment screws are 1/4 X 20. Move 1 turn per 1 dB of imbalance.

All adjustments should be continued until the desired pattern is achieved. Upon completion the antenna should be properly aligned with the satellite for maximum performance.

Survival Struts

The survival struts are used when winds are expected to exceed 125 mph (200 kph). The antenna should be moved to 90 deg. (zenith) elevation. Undo the adjustment nuts holding each strut to the enclosure. Swing each strut down into the adjoining slot in the turning head. Tighten the nuts to the turning head block. Torque the nuts to the full effort of one man using a three-foot wrench.

NOTE:

Do not attempt to operate the azimuth jack while the survival struts are deployed.

Preventive Maintenance

Overview

This section contains periodic preventive maintenance instructions for the 7.6-Meter Earth Station Antenna. Included in this section are inspection and preventive maintenance procedures including cleaning and lubrication, painting, and an operational voltage/current checkout procedure deemed within the capabilities of the average station technician. Refer to applicable vendor manuals for any repair procedures not included in this section yet designated as capable of being performed in the "field" rather than requiring specialized facilities, tools, and/or test equipment as well as technically trained personnel.

An operational checkout procedure provides an accurate indication of the overall earth station performance and should be performed at intervals of approximately three months. This procedure is essentially performed during the various modes of normal operation of the earth station. In addition, the operational checkout procedure should be performed after any repairs or adjustments have been made, or whenever the earth station is suspected of degraded operation. If any discrepancy in performance exists and the condition cannot be readily remedied to return the earth station to a proper operating condition, the appropriate troubleshooting procedures should be referenced to locate the fault. After the trouble is determined and the repairs affected, a final operational checkout procedure should be performed to verify that all discrepancies have been corrected.

The following paragraphs describe the inspection and preventive maintenance procedures for the earth station. These instructions include general cleaning and inspection, the preservation of metal parts and lubrication. Periodic replacement of assemblies or components as a preventive measure is not required. Malfunctions of the earth station can be traced to components, assemblies, and parts through the use of applicable troubleshooting procedures.

General Cleaning

To prevent the excessive accumulation of dust and dirt as well as the removal of such contaminants, thoroughly clean the equipment whenever visually inspecting the earth station components. No special cleaning procedures are required. However, a thorough cleaning in accordance with the following procedures is required to assure continued trouble-free operation.

Electrical Parts

Minor cleaning, such as the removal of dust and loose foreign particles can be accomplished by one of the following:

- Vacuuming
- Using a soft brush or lint-free cloth
- Blowing out the dust and dirt with low pressure (5 to 25 psi), dry compressed air

When using air to blow off the contaminants, either avoid or be careful when directing the air stream on delicate parts. To remove imbedded dirt, grease, or oil from electrical parts; use a 50 percent solution of isopropyl (rubbing) alcohol and apply with a soft bristle brush. It may be necessary to brush some parts vigorously with a stiff bristle brush to remove imbedded and hardened dirt particles. If possible, avoid excessive use of cleaning solvent on electrical insulation. After cleaning, allow the cleaned parts to dry for 10 to 15 minutes before placing the equipment into operation.

Mechanical Parts

Clean mechanical parts by first removing dust, dirt, and other loose contaminants with a scraper, stiff brush (bristle or wire in the case of rust or other corrosion), or cloth or compressed air at 25 to 40 psi. Any accumulated imbedded dirt, corrosion, grease, or oil deposits that require further cleaning may be removed with a bristle or wire brush and a cleaning solvent such as trichlorethylene or equal. After cleaning, allow cleaned parts to dry for 10 to 15 minutes before placing the equipment into operation.

Machined Surfaces (Not Galvanized)

For functional reasons, certain machined surfaces cannot be galvanized. These surfaces must be coated on a regular basis with a rust preventative coating. These surfaces include threaded holes, the azimuth bearing ring, and azimuth bearing mounting surfaces. Andrew recommends the rust preventative coating Cortec VCI-368™. For damp environments, application should be every six months. For dry environments, application once a year should be sufficient.

Inspection

The frequency of inspection is contingent upon the user's individual standards and the operational environment in which the earth station is located. However, a visual inspection of the earth station components should be performed at least semi-annually. Where there are no established wear limits, perform a visual inspection to locate worn or damaged parts which could cause improper functioning of the earth station. It is recommended that the mechanical and electrical inspection be performed on the assembled or partially disassembled equipment to determine the extent of disassembly required prior to completely disassembling a suspected malfunctioning component or module. In the absence of any special inspection requirements, operational tests are the most effective means in isolating parts and assemblies requiring further inspection. Any condition noted during inspection that may preclude continued proper operation of the earth station prior to the next scheduled inspection should be noted. The discrepant condition should be corrected (repaired or replaced) immediately or at the conclusion of the inspection procedure.

Local Control/Motor Drive Controller

Inspection of the local control/motor drive controller conforms generally to standard visual inspection procedures on electromechanical equipment. In addition to these standard procedures, perform the following checks and visual inspections for the specific conditions noted:

- Check the front panel for illegible and indistinct panel markings.
- Check the three position selector switches (Azimuth Off/Slow/Fast, Elevation-Off/Slow/Fast, and Polarization-CCW/Off/CW) for smooth operation, audible clicking at each actuation (left to center and return) and spring return from right to center. For each of the two position selector switches (Azimuth-East/West, Elevation-Up/Down, and Local/Remote) check for smooth operation and audible clicking at each actuation.
- Inspect all wiring and cables for discolorization and burned insulation, dirt, breaks, security of connection and other signs of deterioration. Examine connections for dirt, flux, corrosion, and mechanical defects. Check for loose or broken lacing and cut, brittle, abraided, frayed, or cracked insulation.
- Examine connectors for corrosion, broken inserts and stripped threads. Check connector shells for distortion and dents, and contact pins for bends, misalignment, or other deformities. Check connector inserts for carbon tracking indicating arc-over.

(Cortec VCI-368 is a trademark of Cortec Corporation, 4119 White Bear Pkwy., St.Paul, Mn. 55110, 1-800-426-7832)

- Check all electrical components for dirt, cracks, chips, breaks, discoloration and other signs of deterioration and damage. A discolored, blistered, or burnt condition is evidence of overload. Measure actual value of suspect electrical components and compare against specified value.
- Check transformer for an excessive wax deposit on the surface, discoloration, or a pungent odor indicative of burning varnish denoting overheating or a total breakdown.
- Check all terminal boards for broken or missing terminals and stripped threads. Check tightness of lead attaching hardware.
- Check each starter for a make-after-break provision through the release of one push-button as the alternate pushbutton is pressed.
- Check the relays and contactors for free operation of the armatures and contact condition. The contacts are usable even though pitted, burned, worn, or discolored. The contacts or contactor or relay assembly should be replaced only when the contact material has been completely torn away or worn off.
- Visually inspect all mechanical parts for freedom of operation without binding or interference. Check for security of all hardware and stripped or otherwise damaged threads. Check metallic parts for corrosion, dents, distortion, and other deformation.
- Check for evidence of water inside the enclosure. If any water is in evidence, check that all seals are intact and if not, use a coating of RTV-108 (silicone rubber sealant) to seal any exposed electrical fitting, bolt hole, or other possible water entry to the enclosed electrical components in order to maintain a waterproof condition.
- Check or change humidity absorber.

Antenna

Inspection of the antenna conforms generally to standard visual inspection procedures performed on electromechanical equipment. In addition to these procedures, perform the following checks and visual inspections for the specific conditions noted:

- Inspect all wiring and cables particularly the network to enclosure and enclosure to mount interfaces for discoloration and burned insulation, moisture entry, corrosion, dirt, breaks, security of connection, and other signs of deterioration. Examine connections for dirt, corrosion, and mechanical defects. Check for loose or broken lacing and cut, abraided, frayed, brittle, and cracked insulation.
- Examine connectors for corrosion, broken inserts and stripped threads. Check connector shells for distortion and dents, and contact pins for bends, misalignment or other deformities. Check connector inserts for cracks, and carbon tracking, burns or charring indicating arc-over.

- Check all electrical component for dirt, cracks, chips, breaks, discoloration, and other signs of deterioration and damage. A discolored, blistered, or burnt condition is evidence of overload.
- Operate the azimuth and elevation drives as well as the feed rotation in both the plus and minus direction from the local control/motor drive controller at least once every three months during antenna down time. Check the mechanical limit switches provided at the end points stop antenna and feed movement, and limit travel to prevent structural interference and damage. Check the mechanical limit switches for corrosion and water entry and the arm on each feed limit switch for free movement without binding. Be certain both feed rotation limit switch arms are not distorted and ride centrally on the actuating cam to open their corresponding limit switch.
- Inspect the azimuth and elevation jackscrew boots for security of attachment at both ends, for abrasion, tears, cuts, brittleness and other damage that may expose the jackscrew to the environment (water, dust, etc.). Minor repairs can be made with RTV-108 silicone rubber sealant.
- Visually inspect the feed window for dirt and the feed, feed supports, feed window, and reflector for distortion, foreign object damage and environmental deterioration due to ice and snow, dust, rain, hail, and high winds, etc. which may cause electrical component and/or structural deformation.
- Check the cable attachment to the resolvers and to the LNA or LNB's and enclosure mount interface for security, the cable routing for secure hanger attachment and the cable insulation for cuts, cracking, abrasion, and other deterioration. Check the LNA or LNB's and the resolvers for a secure mechanical attachment. Ensure proper torquing of polarization drive gear box setscrews and appropriate tensioning of corresponding drive chain assembly, if applicable.
- Check (if applicable) that the drain holes in the bottom of the enclosure are not obstructed and there is no evidence of water accumulation. Check the enclosure doors for proper closure and that the door seals are intact, not torn, abraded or otherwise damaged. Check that all other seals are intact and if not, use a coating of RTV-108 (silicone rubber sealant) to seal any exposed electrical fitting, bolt hold, or other possible water entry to electrical components in order to maintain a weatherproof condition. If the enclosure is provided with a vent fan, check for free operation of the fan blade. The fan bearings are permanently lubricated; any binding, abnormal noise or vibration necessitates replacement of the fan assembly. Check and replace the fan filter element if it appears dirty or obstructed with dust.
- Check for the appearance of surface lubricants that will cause the accumulation of dirt and grime. Clean off all excess surface lubricants with a cloth and if required, a cloth dampened not wetted with trichlorethylene, or equal.

Drive System Voltage and Current Checks

- Visually inspect all mechanical parts for freedom of operation with no misalignment, binding or interference. Check all cabling for sufficient slack to prevent cable strain as well as adequate restraint to prevent abrasion or chaffing during antenna and feed movement.
- Check security of antenna mounting and interconnecting assembly hardware. Be certain all electrical grounding connections (including cross-axis grounding straps) are intact and secure, not corroded or broken. Thoroughly clean any noticeable corroded portions of grounding cables, unplated portion of universal terminals and corresponding mounting surfaces using a wire brush. Replace rather than tighten any loose A-325 structural hardware. The hardware distorts at initial installation and once loosened will not maintain the required high strength friction connection. All other assembly and installation hardware should be tightened to its original torqued condition. When installing new structural hardware, do not use a wrench with a lever arm longer than two feet.
- Examine painted aluminum and galvanized surfaces and touch-up where required.

At the conclusion of the installation procedure prior to turning the system over to the station facility, an installation acceptance check off sheet was prepared and duly signed off if installed by Andrew crew. Part of this check off included voltage readings retaken to determine if proper voltage was available. Current readings were also taken as a reference for future comparison to serve as a troubleshooting aid in determining possible equipment degradation and shortened life. Any current reading taken during the following procedure that varies by more than five percent from the pre-established reference values necessitates troubleshooting the particular system involved to determine the cause and required corrective action.

Step 1

Approximately every three months and during a period of down time, disconnect as applicable the RF transmitter and all power supplies. The main disconnect switch in the main load center box at the antenna site must be in the ON position and the LOCAL/REMOTE switch in the local control motor drive controller must be in the LOCAL position.

Step 2

Open the outer local control/motor drive controller door at the antenna site to gain access to the conductors supplying power to the azimuth, elevation, and polarization drive motors.

NOTE: During the following procedures, the antenna drives (azimuth, elevation, and polarization) will be powered to rotate the antenna and feed in both directions of travel. Check that this condition can be tolerated from a safety as well as an operational standpoint, and that the electrical limits are not reached before the testing is concluded. Reaching an electrical limit before concluding a test necessitates rotating the antenna or feed in the opposite direction a sufficient distance to permit retesting in the desired direction.

Step 3

Turn the FEED CCW/OFF/CW switch to either the CW or CCW position and while the feed is rotating, carefully use a clamp on ammeter in accordance with the ammeter manufacturer's instructions to take current readings off each of the three conductors (phases) connected to the load side of the polarization motor circuit breaker. Record the current draw in the equipment log and compare the readings to the reference values entered in

the installation/acceptance check off. If the readings differ by more than five percent, refer to appropriate troubleshooting information and perform applicable corrective action. Then take voltage readings off each of the three conductors; the readings should agree with each other within two percent. Turn the FEED CCW/OFF/CW switch to OFF.

Step 4

Repeat preceding step (3) with the FEED CCW/OFF/CW switch in the alternate operating position.

Step 5

Turn the AZIMUTH EAST/WEST switch to either position and while the antenna is rotating, carefully use a clamp on ammeter in accordance with the ammeter manufacturer's instructions to take current readings off each of the three conductors (phases) connected to the load side of the azimuth drive motor circuit breaker. Record the current draw in the equipment log and compare the readings to the reference values entered in the installation/acceptance check off. If the readings differ by more than five percent, refer to appropriate troubleshooting information and perform applicable corrective action. Then take voltage readings off each of the three conductors; the readings should agree with each other—within two percent. Turn the AZIMUTH switch to OFF.

Step 6

Repeat steps (5) with the AZIMUTH EAST/WEST switch in the alternate operating position.

Step 7

Turn the ELEVATION DOWN/UP switch to either position and while the antenna is rotating, carefully use a clamp on ammeter in accordance with the ammeter manufacturer's instructions to take current readings off each of the three conductors (phases) connected to the load side of the elevation drive motor circuit breaker. Record the current draw in the equipment log and compare the readings to the reference values entered in the installation/acceptance check off. If the readings differ by more than five percent, refer to appropriate troubleshooting information and perform applicable corrective action. Then take voltage readings off each of the three conductors; the readings should agree with each other within two percent. Turn the ELEVATION switch to OFF.

Step 8

Repeat steps (7) with the ELEVATION DOWN/UP switch in the alternate operating position.

Step 9

If all voltage and current readings are within tolerance, close the local control/motor drive controller inner door and place the LOCAL/REMOTE switch in the REMOTE position to return antenna control to the studio. Then close and lock the outer local control/motor drive controller door.

Preservation of Component Parts

Aluminum Parts

When preserving the component parts, refer to the following paragraphs in this section.

Remove all loose paint and corrosion by scraping, wire brushing, or using steel wool. If using steel wool near the feed window, make sure that none remains on the feed horn window. Edges of existing paint can be blended with the metal surface by using a fine grit sandpaper. Wipe the surface to be painted with a soft rag dampened in trichlorethylene, lacquer thinner or equal. Be certain to remove all loose paint, corrosion, imbedded dirt, grease, and oil deposits or the paint will not adhere to the surface. Lacquer thinner will dissolve paint if applied heavily and rubbed vigorously. The reflector may be washed with plain water if necessary. Do not use bleach, soap solutions, or kerosene as it is difficult to remove the residue. Allow the cleaned surface to dry thoroughly before priming.

Prime the cleaned surface by applying zinc chromate primer. The primer can be applied with a brush, roller, or pressurized spray. If necessary, thin the primer with lacquer thinner to the proper consistency. Feather primer onto adjacent painted surfaces;. Allow primer to thoroughly dry before applying the finish paint coat.

Paint all RF surfaces, such as the inside of the main reflector and subreflector with a high-reflectance white paint. This type of paint disperses light rays, reducing the focusing effect of the sun's radiation, thereby reducing heat build-up caused by the focused sun's rays on the feed system. Rear surfaces of the reflector and subreflector may be painted with a flat white enamel paint. The paint can be applied with a brush, roller, or pressurized spray. If necessary, thin the paint with the appropriate thinner to the proper consistency. Thoroughly paint over the primed surfaces and blend with the existing painted surface.

Galvanized Surfaces

Remove all loose paint and corrosion by scraping, wire brushing, or using steel wool. Edges of existing paint can be blended with the metal surface by using a fine grit sandpaper. Wipe the surface to be painted with a soft rag dampened in trichlorethylene, lacquer thinner, or equal. Be certain to remove all loose paint, corrosion, imbedded dirt, grease, and oil deposits or the paint will not adhere to the surface. Lacquer thinner will dissolve paint if applied heavily and rubbed vigorously. Do not use bleach, soap solutions, or kerosene as it is difficult to remove the residue. Allow the clean surface to dry thoroughly before painting.

Paint the cleaned surface with a zinc-rich paint. The paint can be applied with a brush, roller, or pressurized spray. If necessary, thin the paint with the appropriate thinner to the proper consistency. Thoroughly paint over the cleaned surface and blend with the existing painted surface.

Lubrication

For long life and trouble-free operation be certain not to extend the lubrication schedule beyond the frequency recommended in the Lubrication Chart. The frequency should be shortened if the antenna is subjected to an adverse environment (e.g., high temperature, extended periods of rainfall, high humidity, dust storms, etc). Any component or part should immediately be lubricated if during inspection or operation, rough, jarring, or intermittent motion is noted, or if squeaky or other unusual noises are heard. Lubrication is required on all metal-to-metal rolling or sliding parts. Use the lubricants recommended. Do not over lubricate. Over lubrication can often be as damaging as under lubrication. Prior to the application of lubricant to any parts, use a clean cloth and/or bristle brush

and remove any old lubricant to prevent an excessive build-up. Remove indicated access plugs from square tube weldment and apply lubricant to panning frame tube assembly and corresponding thrust pads. Securely replace access plugs in square tube weldment. Be certain to remove any protective caps and clean off each lubrication fitting prior to injecting fresh grease. The elevation and azimuth jackscrew assemblies are equipped with a grease fitting and corresponding pipe plug on opposite sides of the jack housing. Remove the appropriate pipe plug and fill with grease until lubricant seeps from the pipe plug opening. Replace and securely tighten pipe plug.

The following is a list of the lubricant characteristics:

- Mobil Temp SHC32™ A non-soap hydrocarbon fluid type grease. Operating temperature range is -65 degrees to 350+ degrees Fahrenheit (-54 degrees to 177+ degrees Celsius).
- Mobil SHC624™ A low temperature synthetic oil for worm gear reducers. Operating temperature range is -40 degrees to 125+ degrees Fahrenheit (-40 degrees to 52+ degrees Celsius).
- Moly Grease A grease lubricant containing molybdenum disulfide. Operating temperature range is -85 degrees to 300+ degrees Fahrenheit (-29 degrees to 149+ degrees Celsius).

Jackscrews/Motors

Periodically inspect lifting screws on jackscrew assemblies to ensure adequate lubrication. Loosen Jackscrew boot clamps to expose the lifting screw assembly. Fully extend jackscrew assembly being careful not to exceed preset mechanical limits. Brush thin coating of Mobil SHC32 grease on exposed lifting screw. Replace boot and attach corresponding boot clamps. If lifting screw is rusty, remove existing lubricant with solvent and wire brush rusted area. Rinse with solvent and apply fresh grease.

Periodically inspect and remove dust or dirt deposits from the motor housings to avoid hindering the heat exchange with the ambient air. Slight dirt accumulation on the air vent screw through splash oil cannot be avoided; however, keep vent screw clean to ensure proper pressure compensation.

Gear Motor/Housing Fill Drain Requirements

Lube point 2, shown in the Lubrication Chart, requires removal of the indicated drain plugs and collecting/measuring the amount of SHC624 drain oil using measuring cup. The specified amount of oil must be added to the gear motor/housing (after installing the drain plug) via the fill/vent plug opening using supplied funnel. Addition of the oil requires use of an appropriate filling utensil. Use of a modified level stick will not correctly gauge the appropriate amount of oil in the gear housings.

(Mobil Temp SHC32™ and Mobil SHC624™ are trademarks of Exxon Mobil Corporation.)

Lubrication Chart

Lube Point No.	Components to be Lubricated	Frequency (Months)				Type of Service	Type of Lube	No. of Lube Points or Quantity
		1	3	6	12			
1.	Azimuth/Elevation Jackscrew Housing			X		Pressure Fitting	SHC32	1
2. ¹	Azimuth/Elevation Jackscrew Gear Housing Fill and Drain		I*	C**		Pipe Plugs	SHC624	10 Oz
3.	Polarization Drive Gear			X		Brush	SHC32	Minimum Surface Coverage
4.	Feed Rotation Worm Gear Pillow Blocks			X		Pressure Fitting	SHC32	2
5.	Elevation Axis Pivot Points			X		Pressure Fitting	SHC32	2
6.	Azimuth Turntable Bearing			X		Pressure Fitting	SHC32	2

X = Lubricate I = Inspect C = Change

* Inspection requires checking for visible signs of oil leakage, draining replacing and adding oil to ensure appropriate oil level requirements. Excessively dirty oil will require fresh oil replacement. If oil leakage is found to be excessive, refer to appropriate troubleshooting information and perform applicable corrective action. Periodic inspection procedures can be less frequent after first or second scheduled inspections.

** Initial oil change requirements include flushing gear boxes with a standard cleaning agent.

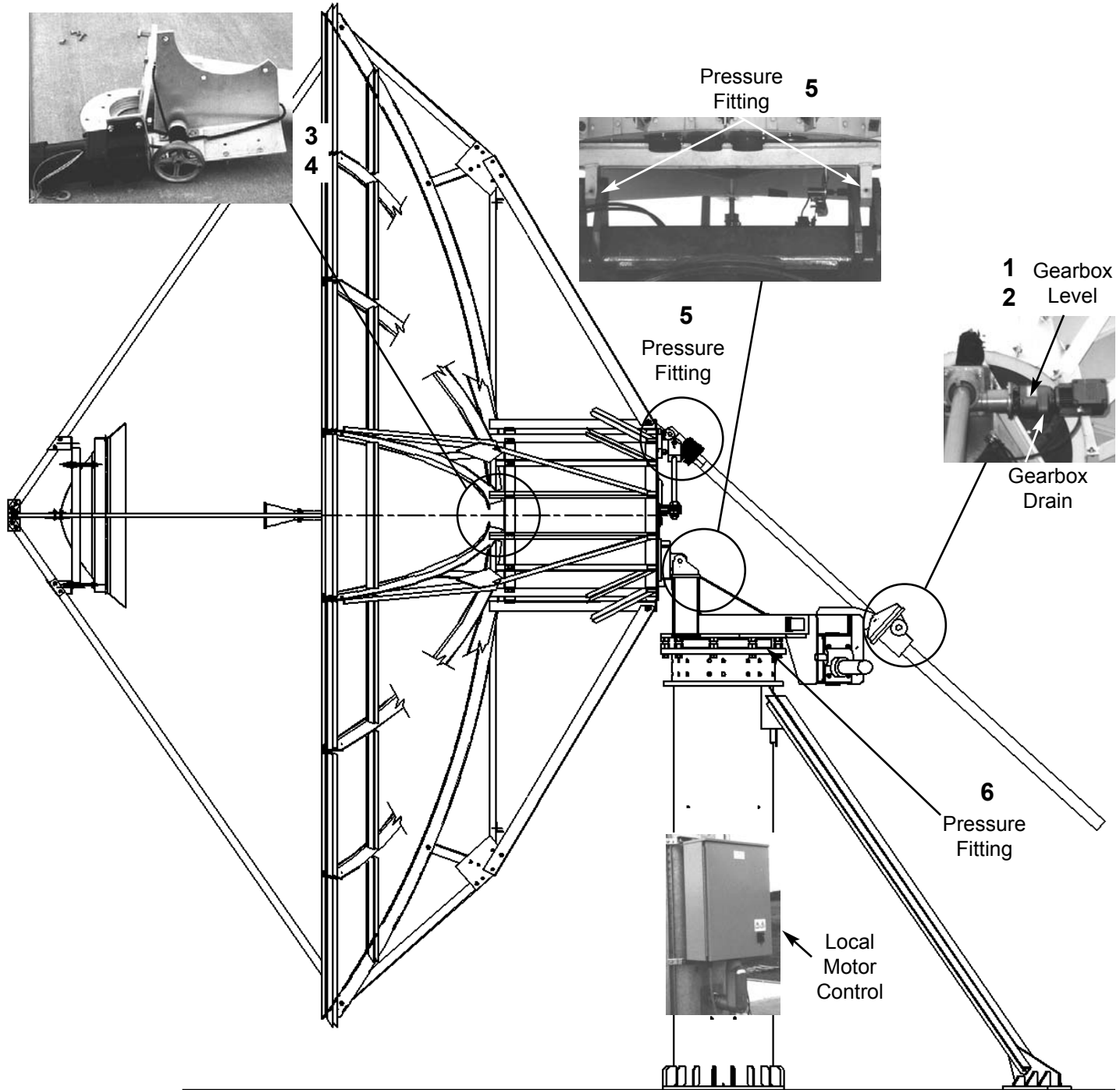

Antenna Lubrication Points

Free Manuals Download Website

<http://myh66.com>

<http://usermanuals.us>

<http://www.somanuals.com>

<http://www.4manuals.cc>

<http://www.manual-lib.com>

<http://www.404manual.com>

<http://www.luxmanual.com>

<http://aubethermostatmanual.com>

Golf course search by state

<http://golfingnear.com>

Email search by domain

<http://emailbydomain.com>

Auto manuals search

<http://auto.somanuals.com>

TV manuals search

<http://tv.somanuals.com>