

LTC 4600 Series

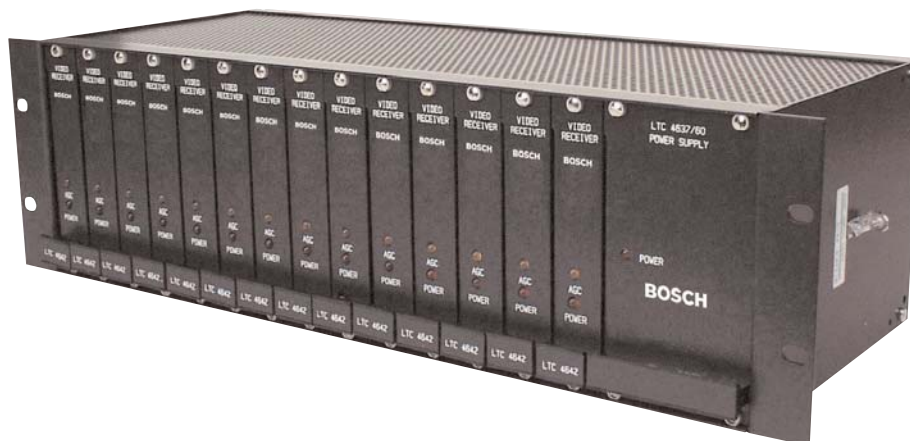

Security Systems

EN | Instruction Manual
Fiber Optic
Transmission System

BOSCH

Important Safeguards

Read, follow, and retain for future reference all of the following safety instructions. Heed all warnings on the unit and in the operating instructions before operating the unit.

1. **Cleaning** - Unplug the unit from the outlet before cleaning. Follow any instructions provided with the unit. Generally, using a dry cloth for cleaning is sufficient, but a moist fluff-free cloth or leather shammy may also be used. Do not use liquid cleaners or aerosol cleaners.
2. **Heat Sources** - Do not install the unit near any heat sources such as radiators, heaters, stoves, or other equipment (including amplifiers) that produce heat.
3. **Ventilation** - Any openings in the unit enclosure are provided for ventilation to prevent overheating and ensure reliable operation. Do not block or cover these openings. Do not place the unit in an enclosure unless proper ventilation is provided, or the manufacturer's instructions have been adhered to.
4. **Water** - Do not use this unit near water, for example near a bathtub, washbowl, sink, laundry basket, in a damp or wet basement, near a swimming pool, in an outdoor installation, or in any area classified as a wet location. To reduce the risk of fire or electrical shock, do not expose this unit to rain or moisture.
5. **Object and liquid entry** - Never push objects of any kind into this unit through openings as they may touch dangerous voltage points or short-out parts that could result in a fire or electrical shock. Never spill liquid of any kind on the unit. Do not place objects filled with liquids, such as vases or cups, on the unit.
6. **Lightning** - For added protection during a lightning storm, or when leaving this unit unattended and unused for long periods, unplug the unit from the wall outlet and disconnect the cable system. This will prevent damage to the unit from lightning and power line surges.
7. **Controls adjustment** - Adjust only those controls specified in the operating instructions. Improper adjustment of other controls may cause damage to the unit. Use of controls or adjustments, or performance of procedures other than those specified, may result in hazardous radiation exposure.
8. **Overloading** - Do not overload outlets and extension cords. This can cause fire or electrical shock.
9. **Power cord and plug protection** - Protect the plug and power cord from foot traffic, being pinched by items placed upon or against them at electrical outlets, and its exit from the unit. For units intended to operate with 230 VAC, 50 Hz, the input and output power cord must comply with the latest versions of IEC Publication 227 or IEC Publication 245.
10. **Power disconnect** - Units with or without ON/OFF switches have power supplied to the unit whenever the power cord is inserted into the power source; however, the unit is operational only when the ON/OFF switch is in the ON position. The power cord is the main power disconnect device for switching off the voltage for all units.
11. **Power sources** - Operate the unit only from the type of power source indicated on the label. Before proceeding, be sure to disconnect the power from the cable to be installed into the unit.
 - For battery powered units, refer to the operating instructions.
 - For external power supplied units, use only the recommended or approved power supplies.
 - For limited power source units, this power source must comply with EN60950. Substitutions may damage the unit or cause fire or shock.
 - For 24 VAC units, voltage applied to the unit's power input should not exceed $\pm 10\%$, or 28 VAC. User-supplied wiring must comply with local electrical codes (Class 2 power levels). Do not ground the supply at the terminals or at the unit's power supply terminals.
 - If unsure of the type of power supply to use, contact your dealer or local power company.
12. **Servicing** - Do not attempt to service this unit yourself. Opening or removing covers may expose you to dangerous voltage or other hazards. Refer all servicing to qualified service personnel.
13. **Damage requiring service** - Unplug the unit from the main AC power source and refer servicing to qualified service personnel when any damage to the equipment has occurred, such as:
 - the power supply cord or plug is damaged;
 - exposure to moisture, water, and/or inclement weather (rain, snow, etc.);
 - liquid has been spilled in or on the equipment;
 - an object has fallen into the unit;
 - unit has been dropped or the unit cabinet is damaged;
 - unit exhibits a distinct change in performance;
 - unit does not operate normally when the user correctly follows the operating instructions.
14. **Replacement parts** - Be sure the service technician uses replacement parts specified by the manufacturer, or that have the same characteristics as the original parts. Unauthorized substitutions may cause fire, electrical shock, or other hazards.

15. **Safety check** - Safety checks should be performed upon completion of service or repairs to the unit to ensure proper operating condition.
16. **Installation** - Install in accordance with the manufacturer's instructions and in accordance with applicable local codes.
17. **Attachments, changes or modifications** - Only use attachments/accessories specified by the manufacturer. Any change or modification of the equipment, not expressly approved by Bosch, could void the warranty or, in the case of an authorization agreement, authority to operate the equipment.

Safety Precautions



DANGER! High risk:

This symbol indicates an imminently hazardous situation such as "Dangerous Voltage" inside the product. If not avoided, this will result in an electrical shock, serious bodily injury, or death.



WARNING! Medium risk:

Indicates a potentially hazardous situation. If not avoided, this could result in serious bodily injury or death.



CAUTION! Low risk: (without safety alert symbol) Indicates a potentially hazardous situation. If not avoided, this may result in property damage or risk of damage to the unit.



NOTICE! This symbol indicates information or a company policy that relates directly or indirectly to the safety of personnel or protection of property.



Important Notices

Accessories - Do not place this unit on an unstable stand, tripod, bracket, or mount. The unit may fall, causing serious injury and/or serious damage to the unit. Use only with the cart, stand, tripod, bracket, or table specified by the manufacturer. When a cart is used, use caution and care when moving the cart/apparatus combination to avoid injury from tip-over. Quick stops, excessive force, or uneven surfaces may cause the cart/unit combination to overturn. Mount the unit per the manufacturer's instructions.

All-pole power switch - Incorporate an all-pole power switch, with a contact separation of at least 3 mm in each pole, into the electrical installation of the building.

If it is needed to open the housing for servicing and/or other activities, use this all-pole switch as the main

disconnect device for switching off the voltage to the unit.

Camera grounding - For mounting the camera in potentially damp environments, ensure to ground the system using the ground connection of the power supply connector (see section: Connecting external power supply).

Camera lens - An assembled camera lens in the outdoor housing must comply and be tested in accordance with UL/IEC60950. Any output or signal lines from the camera must be SELV or Limited Power Source. For safety reasons the environmental specification of the camera lens assembly must be within the environmental specification of -10 °C (14 °F) to 50 °C (122 °F).

Camera signal - Protect the cable with a primary protector if the camera signal is beyond 140 feet, in accordance with NEC800 (CEC Section 60).

Coax grounding -

- Ground the cable system if connecting an outside cable system to the unit.
- Connect outdoor equipment to the unit's inputs only after this unit has had its grounding plug connected to a grounded outlet or its ground terminal is properly connected to a ground source.
- Disconnect the unit's input connectors from outdoor equipment before disconnecting the grounding plug or grounding terminal.
- Follow proper safety precautions such as grounding for any outdoor device connected to this unit.

U.S.A. models only - Section 810 of the National Electrical Code, ANSI/NFPA No.70, provides information regarding proper grounding of the mount and supporting structure, grounding of the coax to a discharge unit, size of grounding conductors, location of discharge unit, connection to grounding electrodes, and requirements for the grounding electrode.



NOTICE! This device is intended for use in public areas only. U.S. federal law strictly prohibits surreptitious recording of oral communications.



Your Bosch product was developed and manufactured with high-quality material and components that can be recycled and reused. This symbol means that electronic and electrical appliances, which have reached the end of their working life, must be collected and disposed of separately from household waste material. Separate collecting systems are usually in place for disused electronic and electrical products. Please dispose of these units at an environmentally compatible recycling facility, per European Directive 2002/96/EC.

Environmental statement - Bosch has a strong commitment towards the environment. This unit has been designed to respect the environment as much as possible.

Electrostatic-sensitive device - Use proper CMOS/MOS-FET handling precautions to avoid electrostatic discharge.

NOTE: Wear required grounded wrist straps and observe proper ESD safety precautions when handling the electrostatic-sensitive printed circuit boards.

Fuse rating - For security protection of the device, the branch circuit protection must be secured with a maximum fuse rating of 16A. This must be in accordance with NEC800 (CEC Section 60).

Grounding and polarization - This unit may be equipped with a polarized alternating current line plug (a plug with one blade wider than the other blade). This safety feature allows the plug to fit into the power outlet in only one way. If unable to insert the plug fully into the outlet, contact a locally certified electrician to replace the obsolete outlet. Do not defeat the safety purpose of the polarized plug.

Alternately, this unit may be equipped with a 3-pole grounding plug (a plug with a third pin for earth grounding). This safety feature allows the plug to fit into a grounded power outlet only. If unable to insert the plug into the outlet, contact a locally certified electrician to replace the obsolete outlet. Do not defeat the safety purpose of the grounding plug.

Moving - Disconnect the power before moving the unit. Move the unit with care. Excessive force or shock may damage the unit and the hard disk drives.

Outdoor signals - The installation for outdoor signals, especially regarding clearance from power and lightning conductors and transient protection, must be in accordance with NEC725 and NEC800 (CEC Rule 16-224 and CEC Section 60).

Permanently connected equipment -

Incorporate a readily accessible disconnect device in the building installation wiring.

Pluggable equipment - Install the socket outlet near the equipment so it is easily accessible.

PoE - Never supply power via the Ethernet connection (PoE) when power is already supplied via the power connector.

Power disconnect - Units have power supplied whenever the power cord is inserted into the power source. The power main power disconnect for all units.

Power lines - Do not locate the camera near overhead power lines, power circuits, or electrical lights, nor where it may contact such power lines, circuits, or lights.

SELV - All the input/output ports are Safety Extra Low Voltage (SELV) circuits. SELV circuits should only be connected to other SELV circuits. Because the ISDN circuits are treated like telephone-network voltage, avoid connecting the SELV circuit to the Telephone Network Voltage (TNV) circuits.

Video loss - Video loss is inherent to digital video recording; therefore, Bosch Security Systems cannot be held liable for any damage that results from missing video information. To minimize the risk of lost digital information, Bosch Security Systems recommends multiple, redundant recording systems, and a procedure to back up all analog and digital information.



NOTICE! This device is intended for use in public areas only. U.S. federal law strictly prohibits surreptitious recording of oral communications.

FCC & ICES INFORMATION

(U.S.A. and Canadian Models Only)

This device complies with part 15 of the FCC Rules.

Operation is subject to the following two conditions:

- (1) This device may not cause harmful interference, and
- (2) This device must accept any interference received, including interference that may cause undesired operation.

NOTE: This equipment has been tested and found to comply with the limits for a Class A digital device, pursuant to Part 15 of the FCC Rules and ICES-003 of Industry Canada. These limits are designed to provide reasonable protection against harmful interference when the equipment is operated in a commercial environment. This equipment generates, uses, and radiates radio frequency energy and, if not installed and used in accordance with the instruction manual, may cause harmful interference to radio communications. Operation of this equipment in a residential area is likely to cause harmful interference, in which case the user will be required to correct the interference at his expense. Intentional or unintentional modifications, not expressly approved by the party responsible for compliance, shall not be made. Any such modifications could void the user's authority to operate the equipment. If necessary, the user should consult the dealer or an experienced radio/television technician for corrective action.

The user may find the following booklet, prepared by the Federal Communications Commission, helpful: How to Identify and Resolve Radio-TV Interference Problems. This booklet is available from the U.S. Government Printing Office, Washington, DC 20402, Stock No. 004-000-00345-4.

Disclaimer

Underwriter Laboratories Inc. ("UL") has not tested the performance or reliability of the security or signaling aspects of this product. UL has only tested fire, shock and/or casualty hazards as outlined in UL's Standard(s) for Safety for Closed Circuit Television Equipment, UL 2044. UL Certification does not cover the performance or reliability of the security or signaling aspects of this product.

UL MAKES NO REPRESENTATIONS, WARRANTIES, OR CERTIFICATIONS WHATSOEVER REGARDING THE PERFORMANCE OR RELIABILITY OF ANY SECURITY OR SIGNALING RELATED FUNCTIONS OF THIS PRODUCT.
Disclaimer

Copyright

This user guide is the intellectual property of Bosch Security Systems, Inc. and is protected by copyright. All rights reserved.

Trademarks

All hardware and software product names used in this document are likely to be registered trademarks and must be treated accordingly.



NOTICE! This user guide has been compiled with great care and the information it contains has been thoroughly verified. The text was complete and correct at the time of printing. The ongoing development of the products may mean that the content of the user guide can change without notice. Bosch Security Systems accepts no liability for damage resulting directly or indirectly from faults, incompleteness or discrepancies between the user guide and the product described.

Table of Contents

Important Safeguards2
FCC Information5
1 UNPACKING7
2 SERVICE7
3 DESCRIPTION7
3.1 Model Summary7
4 INSTALLATION8
4.1 Installing Rack-mount Modules8
4.2 Installing Stand-alone Modules8
4.3 LTC 4641, LTC 4642 Series Modules for Video Transmission9
4.4 LTC 4744, LTC 4745 Series Modules for Simultaneous 4-Channel Video Transmission10
4.5 LTC 4630, LTC 4631 Series Modules for Bilinx™ Video/Data Transmissions11
4.6 LTC 4628, LTC 4629 Series Modules for Video + Bosch Biphase Control Code Transmission ..	.12
4.7 LTC 4671 Series Modules for System4/Allegiantfi Keyboard Transmission14
4.8 LTC 4651 Series Modules for Bosch Biphase Control Code or RS-232 Transmission15
4.9 LTC 4637 Series Rack-mount Card Cage16
5 REPLACEMENT PARTS16
6 TROUBLESHOOTING17
7 DIMENSIONAL OUTLINES18

1 UNPACKING

This electronic equipment should be unpacked and handled carefully. In addition to a copy of these instructions, check for the following items:

1. Stand-alone units:
 - Individual LTC 4600 or LTC 4700 Series Module, and associated Power Supply
2. Rack-mount units:
 - Individual LTC 4600 or LTC 4700 Series Rack Plug-in Module
 - Rack / Power Supply Card Cage
 - Card Cage with integral Power Supply and applicable AC Power Cord

If an item appears to have been damaged in shipment, replace it properly in its carton and notify the shipper. If any items are missing, notify your Bosch Security Systems, Inc. Sales Representative or Customer Service.

The shipping carton is the safest container in which the unit may be transported. Save it for possible future use.

2 SERVICE

If the unit ever needs repair service, the customer should contact the nearest Bosch Security Systems, Inc. Service Center for return authorization and shipping instructions.

Service Centers

USA

Telephone: 800-366-2283 or 585-340-4162

Fax: 800-366-1329

Email: cctv.repair@us.bosch.com

Customer Service

Telephone: 888-289-0096

Fax: 585-223-9180

Email: security.sales@us.bosch.com

Technical Support

Telephone: 800-326-1450

Fax: 585-223-3508 or 717-735-6560

Email: technical.support@us.bosch.com

Repair Center

Telephone: 585-421-4220

Fax: 585-223-9180 or 717-735-6561

Email: security.repair@us.bosch.com

Canada

Telephone: 514-738-2434

Fax: 514-738-8480

Europe, Middle East & Asia Pacific Region

Telephone: 44 (0) 1495 274558

Fax: 44 (0) 1495 274280

Email: rmahelpdesk@solectron.com

3 DESCRIPTION

The LTC 4600 and LTC 4700 Series are transmission systems that provide efficient, high quality video and data transmission via multimode fiber optic cable for improved CCTV system performance. Signals are immune to ground loops, radio frequency interference (RFI), electromagnetic interference (EMI), and cross talk because the video carrier is infrared light, and is transmitted through a nonconductive fiber optic cable. Interference-free operation ensures reliable service. Unlike microwave, wire, and coaxial cable transmission systems, fiber optic transmission is difficult, if not impossible, to tap. And, since fiber optic cable is nonconductive and does not radiate a signal, it is difficult to detect and locate. These compact devices are available in a surface mount enclosure or in a modular style package that can be rack-mounted using an optional EIA 19" compatible rack unit.

3.1 Model Summary

A list of available models is shown below. Complete specifications can be found on the LTC 4600 Series Data Sheet that can be downloaded from www.boschsecuritysystems.com.

Model No.	Description / Use
LTC 4641, LTC 4642 Series	Single Channel Video Transmissions
LTC 4744, LTC 4745 Series	4-Channel Video Transmissions
LTC 4630, LTC 4631 Series	Bilinx™ Video/Data Transmissions
LTC 4628, LTC 4629 Series	Video/Biphase Data Transmissions
LTC 4671 Series	RS-485 Allegiant/Divar™/System4 Keyboard Data Transmissions
LTC 4651 Series	RS-232 / Biphase Data Transmissions
LTC 4637 Series	Card Cage Enclosure for Rack-mount Models

4 INSTALLATION

4.1 Installing Rack-mount Modules

1. Install the LTC 4637 Series card cage unit as described in a later section of this document.
2. Install the fiber optic plug-in module into any available slot of the LTC 4637 Series rack-mount card cage. Certain modules, such as the LTC 4744 and LTC 4745 units are double width, so they require two (2) available rack-mount slots.
 - Push the module in completely, so that the 3-pin connector on the rear of the card engages the 3-pin connector on the back plane.
 - Each fiber optic plug-in module is equipped with a power LED indicator that illuminates when power is applied to the rack unit.
3. Fasten the module into place by tightening the front panel captive screws into the appropriate mating holes with a small flat blade screwdriver.
4. Connect the applicable video and/or data connections to the appropriate connectors, located either on the front or rear of the module. Refer to the example diagrams later in the individual sections.

4.2 Installing Stand-alone Modules

1. Choose an appropriate flat surface where the stand-alone module can be conveniently mounted, then mark the locations of the keyhole slots on the mounting flanges.
 - The LTC 4641 Series Video Transmitter is small enough to be installed inside a camera housing. If applicable, mount the module in a convenient location where it will not obstruct access to other items in the housing.
2. Install the appropriate mounting screws (not supplied) into the keyhole locations. Allow sufficient leeway under the screw head for the module to be mounted.
 - For the LTC 4641 Series Video Transmitter, a single mounting hole is provided to secure the module.
3. For modules other than the LTC 4641 Series, position the module over screw heads, slide to one side, and then tighten screws.
4. Connect the cable from the supplied power supply to the power input terminals on the module.
5. Connect the supplied power supply to an appropriate power source.
6. Connect the applicable video and/or data connections to the appropriate connectors on the module. Refer to example diagrams for exact details.

4.3 LTC 4641, LTC 4642 Series Modules for Video Transmission

4.3.1 Indicators / Operation

1. The POWER LED illuminates when AC power is applied to the unit.
2. LTC 4642/60 and LTC 4642/50 units: The Video Out / AGC LED illuminates GREEN when a video signal is being received, or RED if a video signal is not present.

Typical Configurations:

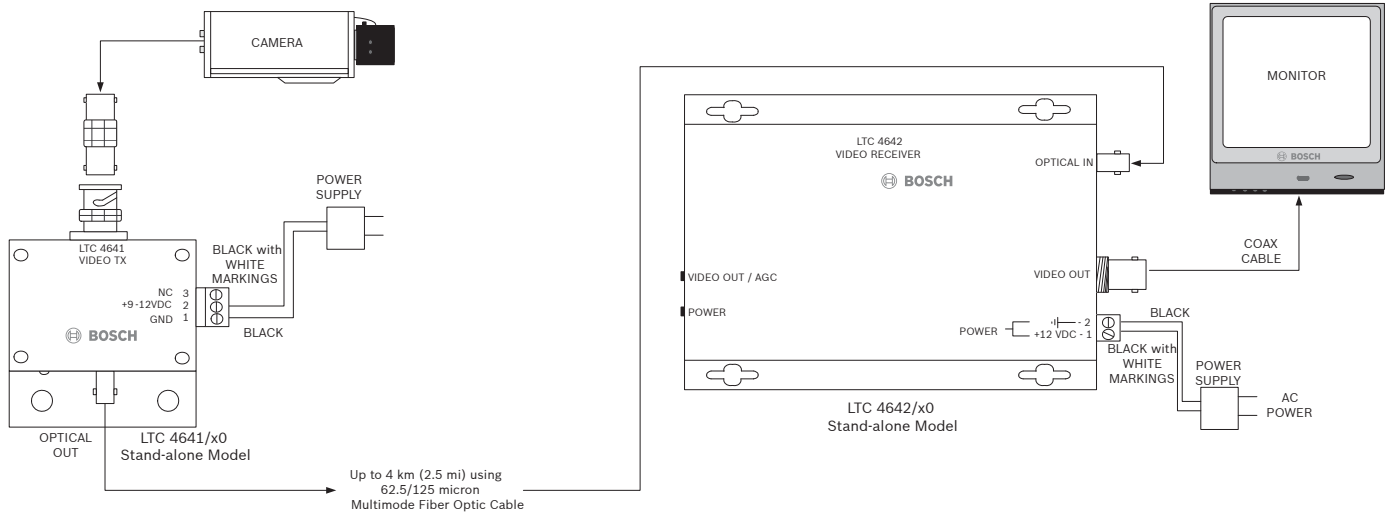

Figure 1 LTC 4641 Series Stand-alone Transmitter and LTC 4642 Series Stand-alone Receiver

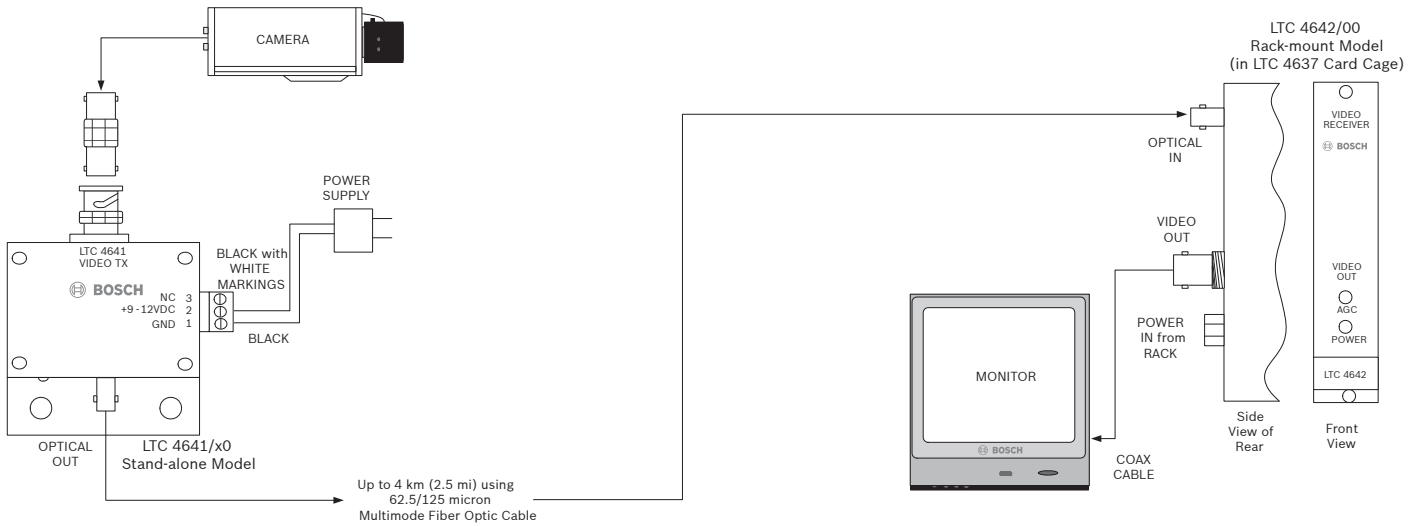

Figure 2 LTC 4641 Series Stand-alone Transmitter and LTC 4642 Series Rack-mount Receiver

4.4 LTC 4744, LTC 4745 Series Modules for Simultaneous 4-Channel Video Transmission

4.4.1 Indicators / Operation

1. The POWER LED illuminates when AC power is applied to the unit.
2. LTC 4744/00 units: Although this module provides both front and rear mounted BNC input connectors for installation convenience, each input channel is capable of accepting only a single video signal.

NOTE: Avoid simultaneously connecting video signals to both the front BNC and rear BNC of the same channel. Also, since each video channel is factory terminated to 75 ohm, unused BNCs should not be used for loop-through video connections.

3. LTC 4744/60, LTC 4744/50, and LTC 4744/00 units: The respective CAMERA ON LED illuminates when a video signal is connected to its input.
4. LTC 4745/60, LTC 4745/50, and LTC 4745/00 units: The LOCAL VIDEO ON LED illuminates when the respective channel of the unit is providing a video signal output. The REMOTE VIDEO ON LED illuminates when a video signal is connected to the respective input of the LTC 4744 Series transmitter.

Typical Configuration:

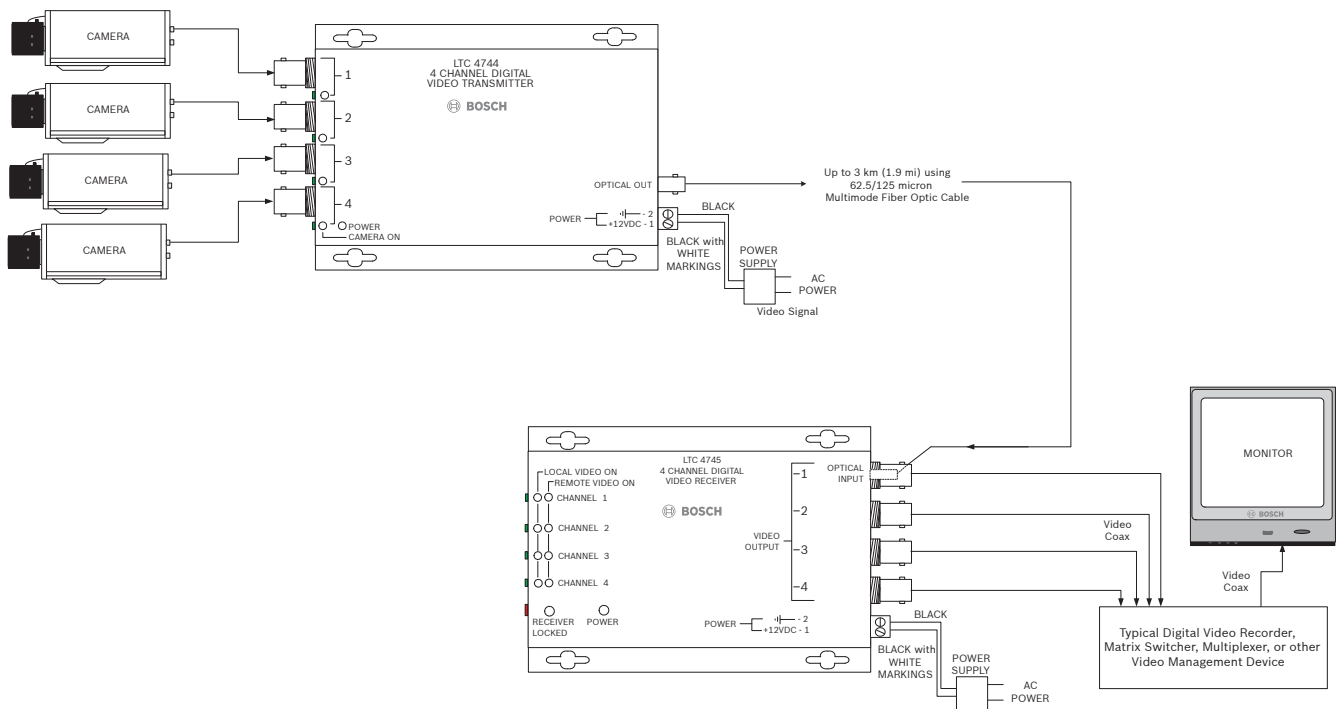

Figure 3 LTC 4744 Series Stand-alone Transmitter and LTC 4745 Series Stand-alone Receiver

4.5 LTC 4630, LTC 4631, Series Modules for Bilinx Video/Data Transmissions

4.5.1 Important Considerations

1. To ensure proper Bilinx communications, the video output of the LTC 4631 Series module must be terminated into a proper 75 ohm load. If improper video looping connections are used, erratic or no camera P/T/Z control may result.
2. Do not exceed the published distance specification for Bilinx communications. Erratic or no camera P/T/Z control may result. Refer to the data sheet for product specifications.
3. Although these modules are compatible with Bilinx *up-the-coax* communication technology found in Bosch Security System products, compatibility is not guaranteed when used with similar technologies employed by other manufacturers.

4.5.2 Indicators / Operation

1. The POWER LED illuminates when AC power is applied to the unit.
2. LTC 4631 Series units: Once the video signal and fiber optic connections have been completed, the state of the VIDEO OUT and AGC LED indicators should be examined. If both are GREEN, test the VIDEO OUT LED action by temporarily removing the video signal from the LTC 4630 module. The LED should turn RED.

If necessary, adjust the AGC control in small increments until the correct LED actions are obtained. Marginal signal strengths are indicated by an AMBER color LED, and a RED LED indicates video loss, or that further adjustments are needed. The adjustment is sensitive. Adjust the control too high, and the VIDEO OUT LED may remain lit even when the video signal is removed or lost. If adjusted too low, the VIDEO OUT LED may remain RED even if a video signal is present.

Typical Configuration:

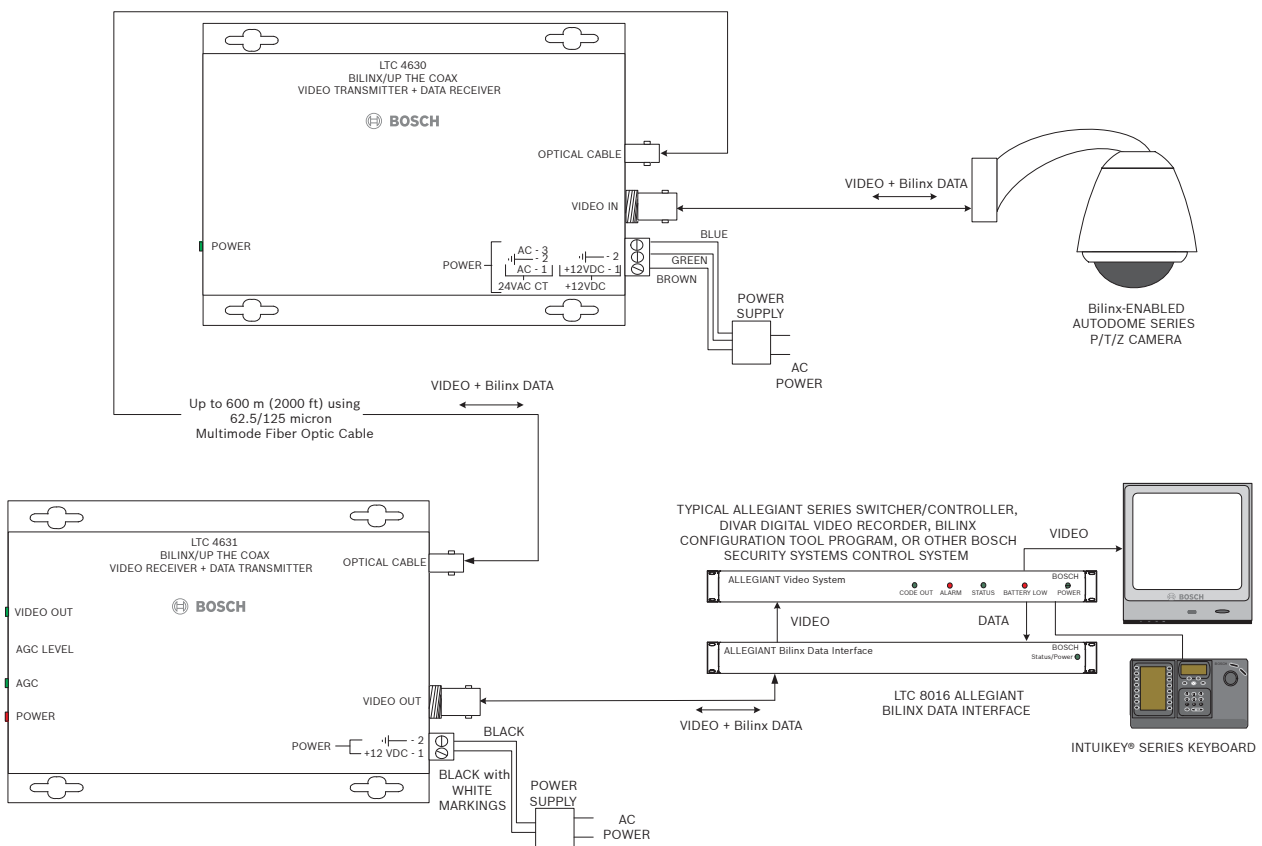

Figure 4 LTC 4630 Series and LTC 4631 Series Stand-alone Bilinx Transceivers

4.6 LTC 4628, LTC 4629 Series Modules for Video + Bosch Biphas Control Code Transmission

4.6.1 Indicators / Operation

1. The POWER LED illuminates when AC power is applied to the unit.
2. LTC 4628/60, LTC 4628/50, and LTC 4628/00 units: The VIDEO PRESENT LED illuminates GREEN when a valid video signal is present, or RED if no video is being received. The DATA RECEIVE LED illuminates RED when no data is received, and flashes YELLOW as data is received.
3. LTC 4629/60, LTC 4629/50, and LTC 4629/00 units: The VIDEO OUT LED illuminates GREEN when a valid video signal is present on the LTC 4628 Series Transmitter, or RED if no video is present. The DATA IN LED illuminates RED if no data is being received on the optical signal, and flashes YELLOW as data is received.

4.6.2 Optional Connection

Because of signal amplitude variations and possible EMI/RFI noise interference in the Biphas control data line, the pan/tilt device may operate erratically or intermittently when first connected. If this is the case, add the supplied 120 ohm termination resistor across the data connections of the LTC 4629 fiber optic module located at the controller site.

If the supplied resistor is damaged or lost, any locally obtained conventional 1/4 watt carbon resistor between 100 and 120 ohms will suffice.

Typical Configurations:

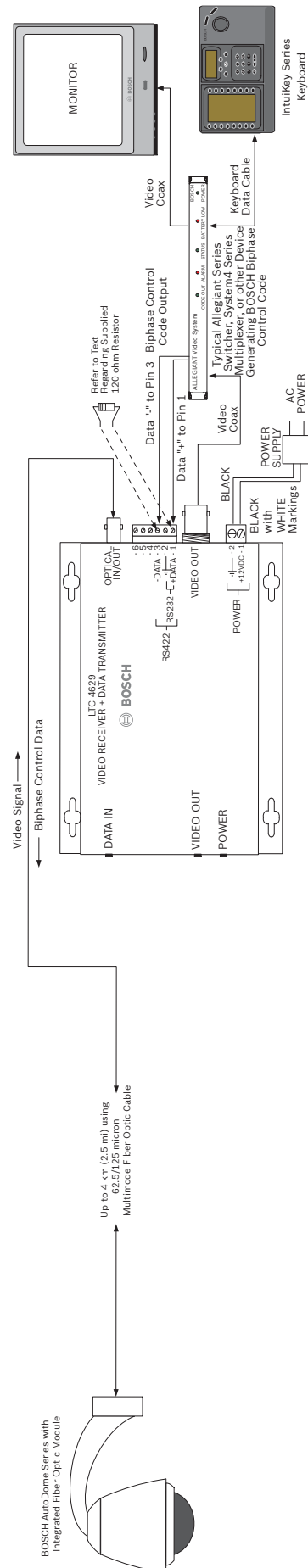

Figure 5 LTC 4629 Series Stand-alone Transceiver Used with AutoDome® Fiber Unit

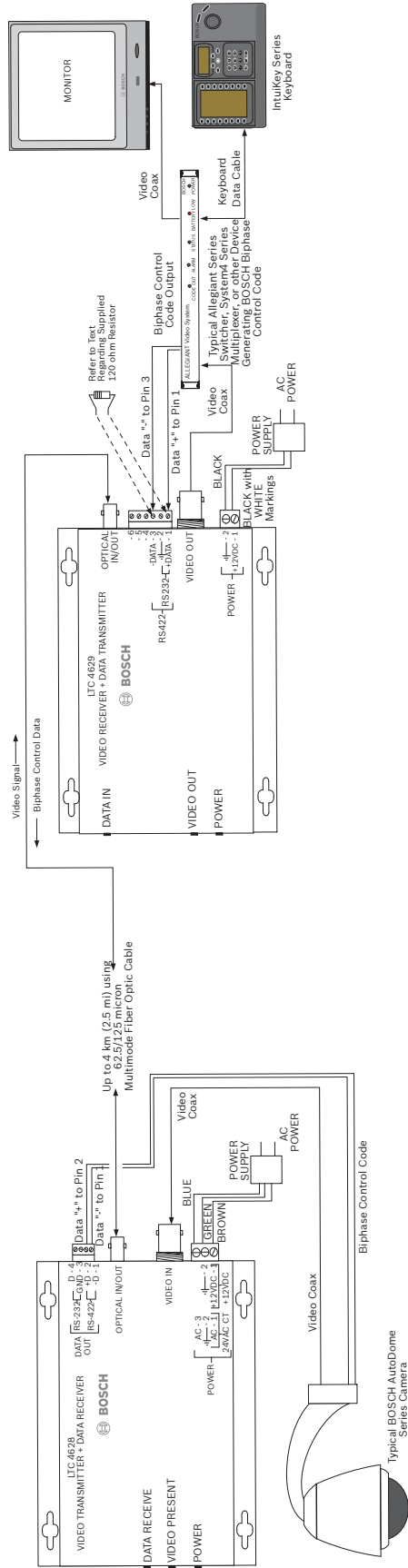

Figure 6 LTC 4628 and LTC 4629 Series Stand-alone Transceivers

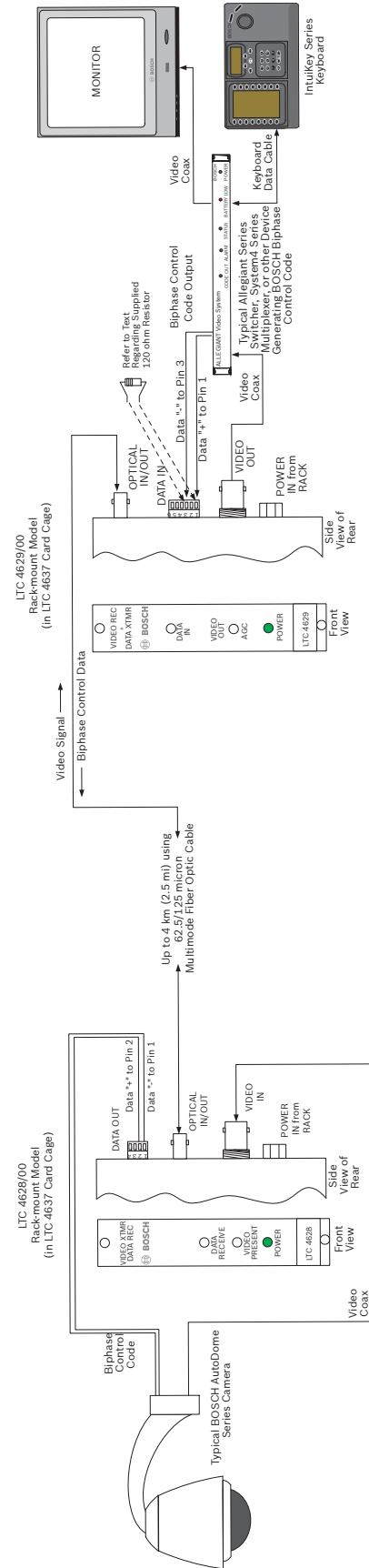

Figure 7 LTC 4628/00 and LTC 4629/00 Rack-mount Transceivers

4.7 LTC 4671 Series Modules for System4 / Allegiant Keyboard Transmission

1. The supplied 120 ohm resistor must be installed across the external data connections when these fiber optic modules are used with certain controller devices. Follow the guidelines below, however, because of differences between the hardware of new and old controller units, these cases are not absolute. If a configuration does not work when first connected without using a termination resistor, try adding the termination resistor across the data connections of the fiber optic module located at the controller site.

A termination resistor is typically required when a module is connected to the following controller devices:

- Allegiant LTC 8100 Series main CPU bays
- Allegiant LTC 8200 Series main CPU bays
- Allegiant LTC 8300 Series main CPU bays
- Allegiant LTC 8900 Series main CPU bays
- LTC 8714 Series Allegiant Keyboard Expander accessory units sold prior to 2002
- LTC 2604 Series Multiplexer Keyboard Expander

Typical Configuration:

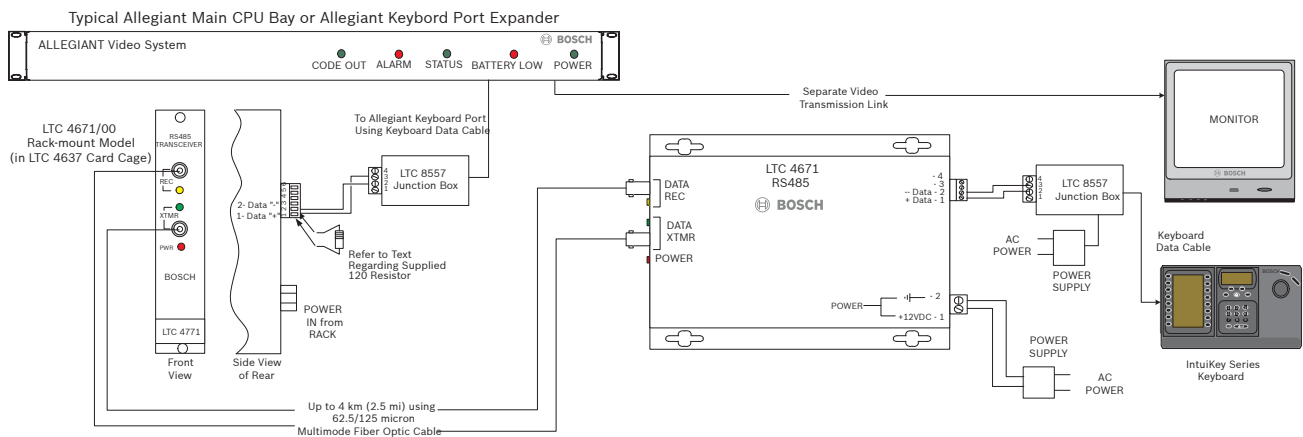

Figure 8 LTC 4671 Series Stand-alone Transceiver and LTC 4671 Rack-mount Transceiver

A termination resistor is typically NOT required when a module is connected to the following controller devices:

- Allegiant LTC 8500 Series main CPU bays
- Allegiant LTC 8600 Series main CPU bays
- Allegiant LTC 8800 Series main CPU bays
- LTC 8714 Series Allegiant Keyboard Expander accessory units sold during or after 2002

If the supplied resistor is damaged or lost, any locally obtained conventional 1/4 watt carbon resistor between 120 ohm and 390 ohm should suffice.

2. The POWER LED will light when AC power is applied to the unit.
3. The DATA XTMR LED will flash as the external data received by the unit is being optically transmitted.
4. The DATA REC LED will flash as optical data is being received by the unit.

4.8 LTC 4651 Series Modules for Bosch Biphas Control Code or RS-232 Transmission

4.8.1 Indicators / Operation

1. The POWER LED will light when AC power is applied to the unit.
2. The TRANSMIT LED flashes as the external data received by the unit is optically transmitted.
3. The RECEIVE LED flashes as optical data is received by the unit.

Typical Configurations:

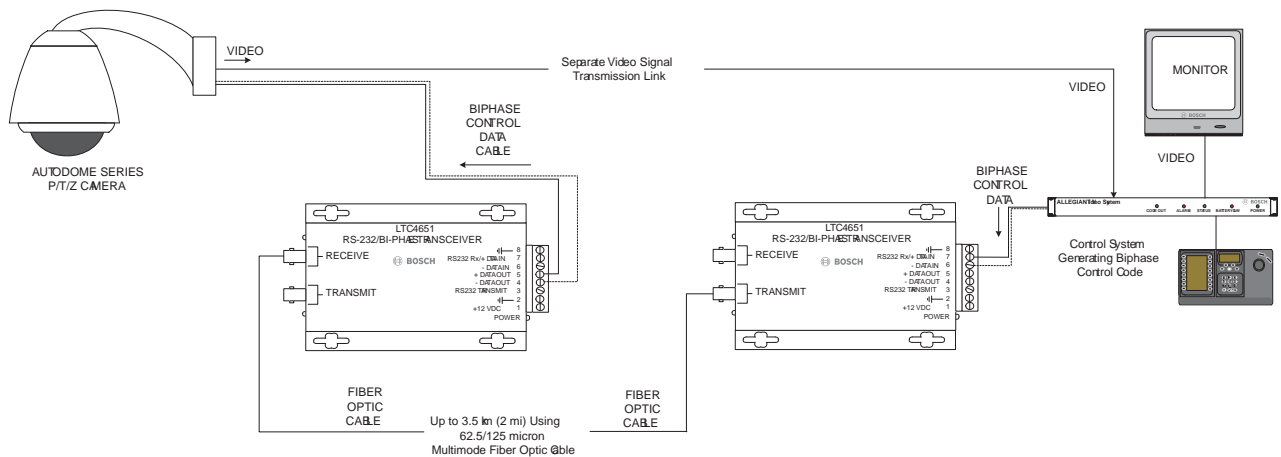

Figure 9 LTC 4651 Series Stand-alone Transceivers Biphas Code Transmission

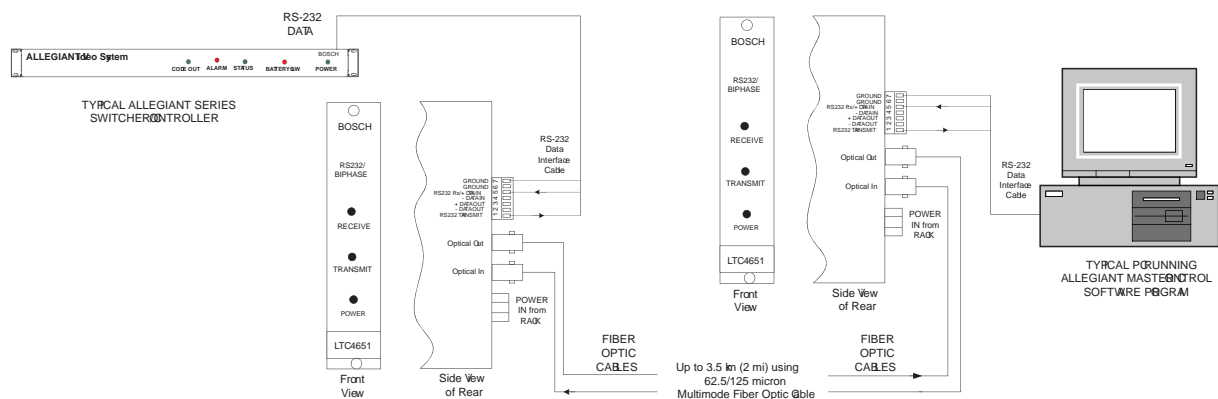

Figure 10 LTC 4651 Series Rack-mount Transceivers RS-232 Transmission

4.9 LTC 4637 Series Rack-mount Card Cage

4.9.1 Installation

1. Install the LTC 4637 Series Rack-mount into a standard EIA 19in. rack, using user-supplied rack-mounting hardware. Be careful to not damage exposed objects on the back of the card cage unit.
2. If a secondary earth ground connection is needed, a grounded wire with a ground lug can be attached to the rack using the protruding screw provided on the right side of the chassis.
3. Connect the supplied AC voltage line cord between the rear of the power supply and the appropriate AC voltage source.
4. Fiber optic plug-in modules can be installed into any of the available 14 slots of the card cage. Most modules require only a single slot width, but others, such as the LTC 4644 and LTC 4645 Series, require two slot widths.
5. If desired, LTC 4600/00 blank panels (ordered separately) may be installed to cover unused slots. A single blank panel covers a single slot opening.
6. Refer to the sections of this manual for specific installation instructions regarding the plug-in modules.

4.9.2 Indicators

1. LTC 4637 Series front panel LED illuminates when AC power is applied to the unit.
2. Each fiber optic plug-in module is equipped with a POWER LED indicator that illuminates when power is applied to the rack unit.

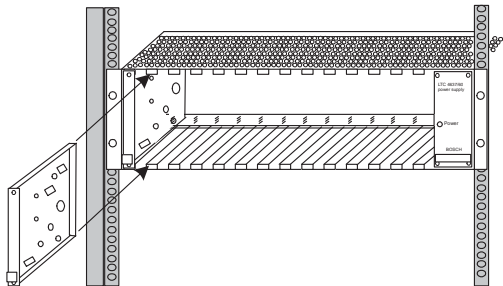

Figure 11 LTC 4637 Series Typical Installation

4.9.3 LTC 4637 Maintenance / Service Information

1. The power supply is fused with a 1A slow blow fuse. To replace the fuse, remove the AC power line cord from the power supply, and carefully pry out the fuse module above the AC connector.
2. The 3-pin connector on the rack supplies a 20VAC center tapped voltage, and is the only electrical connection from the back plane to a plug-in module. Each plug-in module contains its own fuse, so in the unlikely event of a module failure, the other modules in the rack remain unaffected.
3. The power supply is modular in construction, and can be replaced in the event of damage or failure. To remove the power supply from the rack:
 - a) Disconnect the AC line cord and power supply cable from the circuit board back plane, located on the rear of the card cage.
 - b) Loosen the four (4) screws located at the front of the power supply using a small flat blade screwdriver. Slide the power supply out of the card cage.
 - c) Reverse the above procedure to install the power supply into the card cage.

5 REPLACEMENT PARTS

UPA-1509-60	Power Supply for 120VAC Stand-alone Modules
UPA-1509-50	Power Supply for 230VAC Stand-alone Modules

6 TROUBLESHOOTING

Video Links:	
Video Problems	<p>Verify that a valid video signal is being applied to the transmitter module.</p> <p>Verify the integrity of the coax connections between devices and fiber modules.</p> <p>Verify that the correct fiber cable is being used (i.e., multimode only).</p> <p>Verify that the length of the fiber optic cable and associated splices do not exceed the allowable optical loss budget.</p>
Power Problems	<p>Verify the power cable connections between modules and power pack.</p> <p>Verify that the power pack is connected to the appropriate AC power source.</p>
Data Links:	
Data Transmission Problems	<p>Verify the polarity of data connections between devices.</p> <p>If data transmission is not working over the fiber link, verify that a direct connection between the associated products operates correctly.</p> <p>Verify the integrity of the data cable connections between devices and fiber modules.</p> <p>Verify that the correct fiber cable is being used (i.e., multimode only).</p> <p>Verify that the length of the fiber optic cable and associated splices do not exceed the allowable optical loss budget.</p> <p>When using LTC 4671 Series RS-485 modules, review the text regarding the usage of termination resistor.</p>
Power Problems	<p>Verify power cable connections between modules and power pack.</p> <p>Verify that the power pack is connected to the appropriate AC power source.</p>
LTC 4637 Series Rack-mount Configurations:	
Power LED on the Power Supply Fails to Light	<p>Verify that the AC line cord is connected to an appropriate AC voltage source.</p> <p>Check and/or replace the AC fuse located near the AC connector on the rear of the power supply.</p>
Power LED on all Plug-in Modules Fails to Light	<p>Verify that the power supply cable to the circuit board back plane (located on the rear of the card cage) is properly connected.</p>
Power LED on Individual Plug-in Modules Fails to Light	<p>Verify that affected plug-in modules are properly seated onto the back plane 3-pin connector.</p> <p>Verify that fuses on the affected plug-in modules are intact. If not, return for repair.</p>

7 DIMENSIONAL OUTLINES

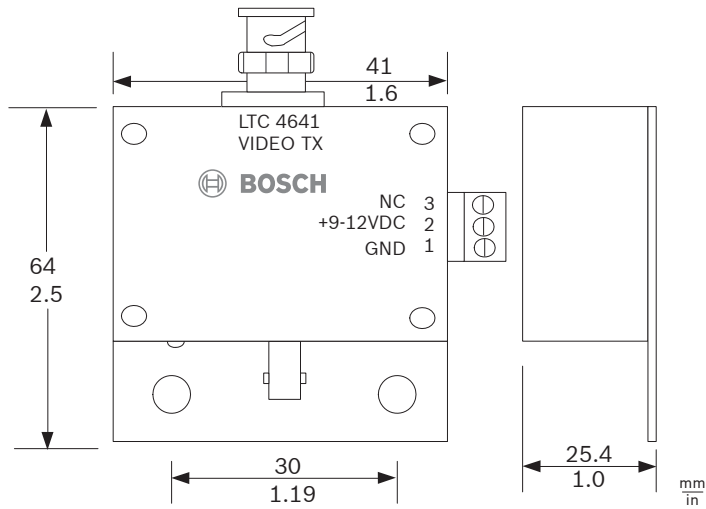

Figure 12 Stand-alone Modules: LTC 4641/60, LTC 4641/50

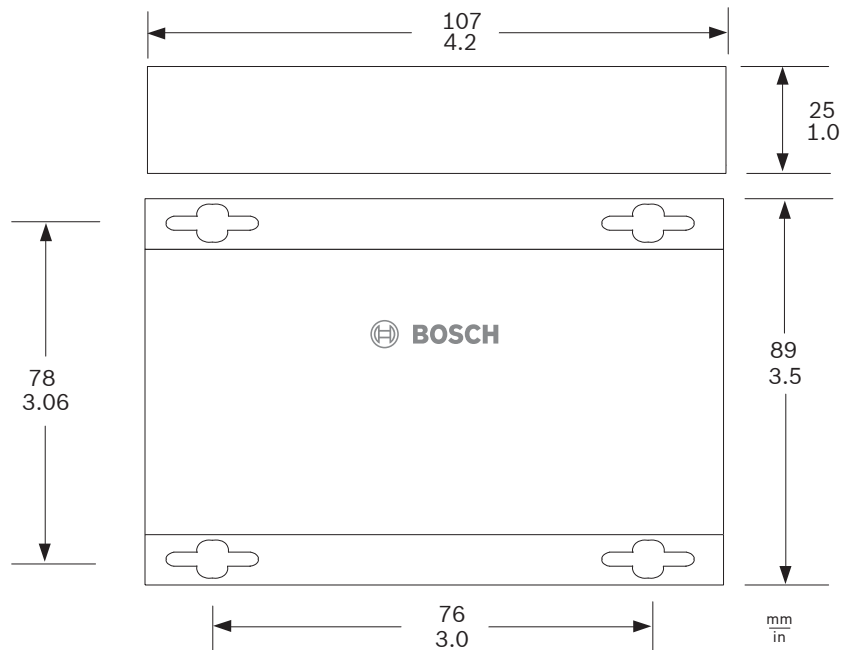

Figure 13 Stand-alone Modules: LTC 4642/50, LTC 4642/60,
LTC 4651/60, LTC 4651/50

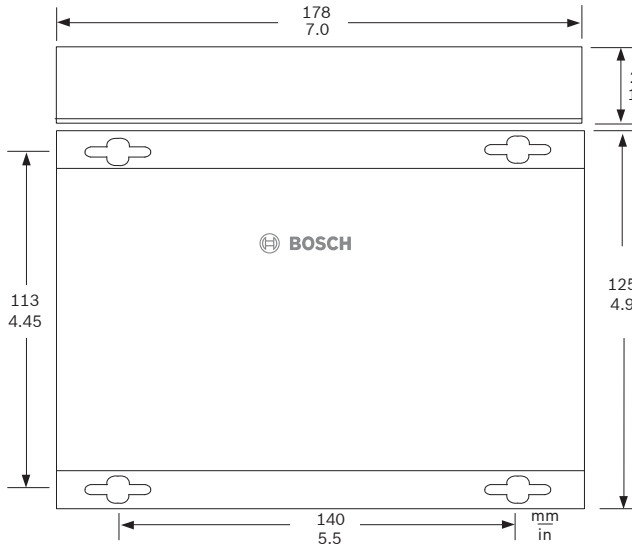
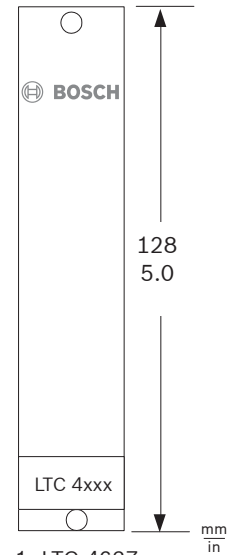

Figure 14 Stand-alone Modules: LTC 4744/50, LTC 4744/60, LTC 4671/60, LTC 4671/50, LTC 4628/60, LTC 4628/50, LTC 4629/60, LTC 4629/50, LTC 4630/50, LTC 4630/60, LTC 4631/50, LTC 4631/60



1 LTC 4637
Rack Width

Figure 16 Rack-mount Modules: LTC 4600/00, LTC 4642/00, LTC 4651/00, LTC 4671/00, LTC 4628/00, LTC 4629/00, LTC 4630/00, LTC 4631/00

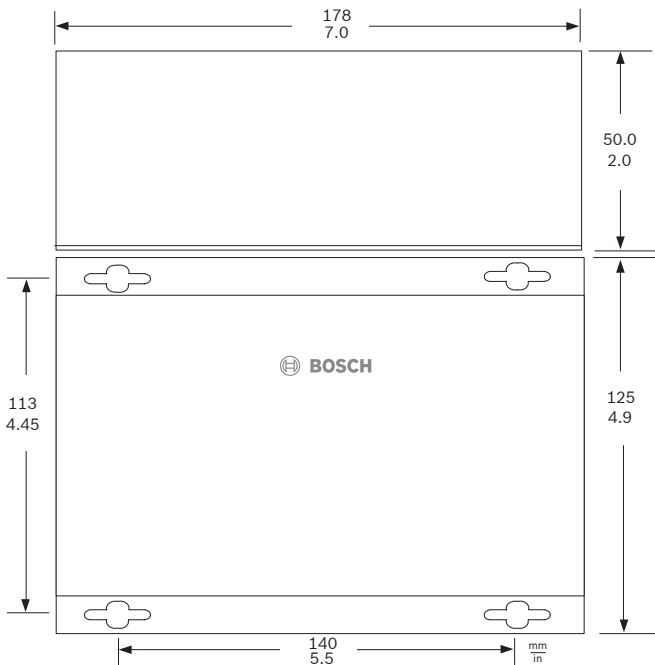
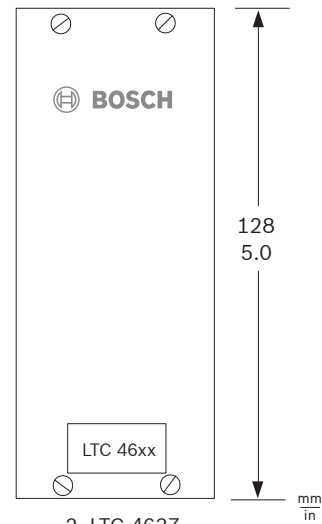

Figure 15 Stand-alone Modules: LTC 4745/50, LTC 4745/60



2 LTC 4637
Rack Widths

Figure 17 Rack-mount Modules: LTC 4744/00, LTC 4745/00

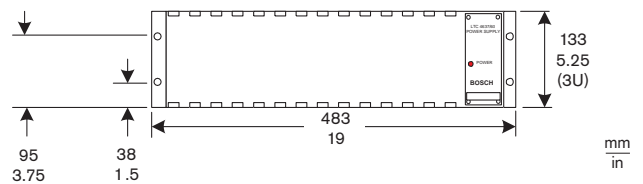

Figure 18 Card Cage: LTC 4637/60, LTC 4637/50

Americas

Bosch Security Systems, Inc.
850 Greenfield Road
Lancaster, Pennsylvania 17601
USA
Telephone+1 888-289-0096
Fax +1 585-223-9180
Email: security.sales@us.bosch.com
www.boschsecurity.us

Europe, Middle East, Africa:

Bosch Security Systems B.V.
P.O. Box 80002
5600 JB Eindhoven, The Netherlands
Phone: + 31 40 2577 284
Fax: +31 40 2577 330
emea.securitysystems@bosch.com
www.boschsecurity.com

Asia-Pacific:

Bosch Security Systems Pte Ltd
38C Jalan Pemimpin
Singapore 577180
Phone: +65 6319 3450
Fax: +65 6319 3499
apr.securitysystems@bosch.com
www.boschsecurity.com

© 2008 Bosch Security Systems, Inc.

F01U087540 08-28 | Updated July 08, 2008 | Data subject to change without notice.

BOSCH

Free Manuals Download Website

<http://myh66.com>

<http://usermanuals.us>

<http://www.somanuals.com>

<http://www.4manuals.cc>

<http://www.manual-lib.com>

<http://www.404manual.com>

<http://www.luxmanual.com>

<http://aubethermostatmanual.com>

Golf course search by state

<http://golfingnear.com>

Email search by domain

<http://emailbydomain.com>

Auto manuals search

<http://auto.somanuals.com>

TV manuals search

<http://tv.somanuals.com>