

CE labs can support many areas of your audio and video distribution needs.

We manufacture:

- Digital Signage software and Media Players
- HD Matrix Switchers
- RF amplifiers
- HDMI and Component HD distribution amplifiers
- CAT 5 Signal Extenders
- VGA Extenders and Splitters
- and cables of all types.

See our full product line at [www.celabs.net](http://www.celabs.net)

## WARRANTY

Cable Electronics, Inc. warrants this product to be free from defects in material and workmanship, under normal use and service, for a period of one year from the purchase by the original purchaser. If this product is defective or malfunctions, Cable Electronics will replace or repair this unit (at their option) within a reasonable time. No expressed or implied warranty is made for any defects caused by immersion or exposure to liquids, abuse, neglect, improper operation of unit, excess wear and tear and defects resulting from unauthorized disassembly and or modification.



3209 Wood Drive  
Garland, TX 75041  
Phone: (469) 429-9200  
Toll free: (800) 767-6189  
Fax: (469) 429-9205  
[www.celabs.net](http://www.celabs.net)

Document: HSW88C\_manual.pdf

# INSTRUCTION MANUAL

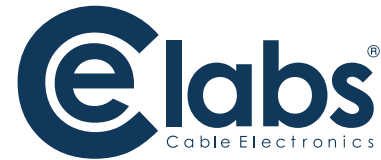

## HSW88C

8x8 HDMI over CAT5 Matrix  
with IR Pass-through



## SAFETEY NOTICE

The HSW88C v1.3 8x8 HDMI over CAT5 Matrix with IR Pass-through has been tested for conformance to safety regulations and requirements, and has been certified for international use. However, like all electronic equipment, the HSW88C should be used with care. Please read and follow the safety instructions to protect yourself from possible injury and to minimize the risk of damage to the unit.

- Follow all instructions and warnings marked on this unit.
- Do not attempt to service this unit yourself, except where explained in this manual.
- Provide proper ventilation and air circulation and do not use near water.
- Keep objects that might damage the device and assure that the placement of this unit is on a stable surface.
- Use only the power adapter and power cords and connection cables designed for this unit.
- Do not use liquid or aerosol cleaners to clean this unit. Always unplug the power to the device before cleaning.

## NOTICE

1. If the DVI or HDMI device requires the EDID information, please use EDID Reader/Writer to retrieve and provide DVI/HDMI EDID information.
2. All HDMI over CAT5 transmission distances are measured using Belden 1583A CAT5e 125MHz LAN cable and ASTRODESIGN Video Signal Generator VG-859C.
3. The transmission length is largely affected by the type of LAN cables, the type of HDMI sources, and the type of HDMI display. The testing result shows solid LAN cables (usually in bulk cable 300m/1000ft form) can transmit a lot longer signals than stranded LAN cables (usually in patch cord form). Shielded STP cables are better suit than unshielded UTP cables. A solid UTP CAT5e cable shows longer transmission length than stranded STP CAT6 cable. For long extension users, solid LAN cables are your only choice.
4. EIA/TIA-568-B termination (T568B) for LAN cables is recommended for better performance.
5. To reduce the interference among the unshielded twisted pairs of wires in LAN cable, you can use shielded LAN cables to reduce EMI problems, which is worsen in long transmission.
6. Because the quality of the LAN cables has major effects in transmission distance, always use high quality cables. For resolution greater than 1080i or 1280x1024, a CAT6 solid wire cable is recommended.
7. If your HDMI display has multiple HDMI inputs, it is found that the first HDMI input [HDMI input #1] generally can produce better transmission performance among all HDMI inputs.
8. The HSMR has been tested extensively and found that it doesn't require external power supply. If in rare situation you find it cannot work with the HSW88C, please use a +5V power adapter to plug in the power jack and try again. If not, please contact your technical support for further service.
9. Additional IR remote controls and IR blaster cables can be purchased as optional accessories to control the HDMI sources located separately.

At: CE labs, 3209 Wood Dr., Garland, TX 75041, [www.celabs.net](http://www.celabs.net)  
 Phone: (469) 429-9200 | Toll free: (800) 767-6289 | Fax: (469) 429-9205

## Performance Guide for HDMI over LAN Cable Transmission

Performance rating		Type of LAN cable		
Wiring	Shielding	CAT5	CAT5e	CAT6
Solid	Unshielded (UTP)	***	****	*****
	Shielded (STP)	***	***	****
Stranded	Unshielded (UTP)	*	**	**
	Shielded (STP)	*	*	**
<b>Termination</b>		Please use <b>EIA/TIA-568-B</b> termination ( <b>T568B</b> ) at any time		

## 7. Output Port:

Pull down menu and select which source to be sent to this output port.

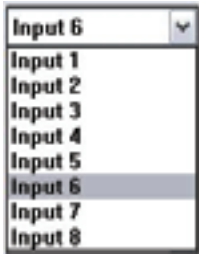

One by one setting

On main menu screen.

First select input source. Then select the output ports which you want to send the video and audio from this source. When you select the input source, the source will change to gray. When you select the output port one by one, the selected output port will change to gray.

The linking line will change to yellow.

Group setting

First select output ports one by one. Then select the input source.

The selected output ports change the setting at the same time.

Terminal Settings:

Baud rate: 9600  
 Data length: 8bit  
 Parity check: No  
 Stop bit: 1

## Command Set:

COMMAND	ACTION	COMMAND	ACTION	COMMAND	ACTION
ST	System Status*	C5	Output C select Input5	F3	Output F select Input3
VR	Firmware Version	C6	Output C select Input6	F4	Output F select Input4
A1	Output A select Input1	C7	Output C select Input7	F5	Output F select Input5
A2	Output A select Input2	C8	Output C select Input8	F6	Output F select Input6
A3	Output A select Input3	D1	Output D select Input1	F7	Output F select Input7
A4	Output A select Input4	D2	Output D select Input2	F8	Output F select Input8
A5	Output A select Input5	D3	Output D select Input3	G1	Output G select
A6	Output A select Input6	D4	Output D select Input4	G2	Output G select
A7	Output A select Input7	D5	Output D select Input5	G3	Output G select
A8	Output A select Input8	D6	Output D select Input6	G4	Output G select
B1	Output B select Input1	D7	Output D select Input7	G5	Output G select
B2	Output B select Input2	D8	Output D select Input8	G6	Output G select
B3	Output B select Input3	E1	Output E select Input1	G7	Output G select
B4	Output B select Input4	E2	Output E select Input2	G8	Output G select
B5	Output B select Input5	E3	Output E select Input3	H1	Output H select
B6	Output B select Input6	E4	Output E select Input4	H2	Output H select
B7	Output B select Input7	E5	Output E select Input5	H3	Output H select
B8	Output B select Input8	E6	Output E select Input6	H4	Output H select
C1	Output C select Input1	E7	Output E select Input7	H5	Output H select
C2	Output C select Input2	E8	Output E select Input8	H6	Output H select
C3	Output C select Input3	F1	Output F select Input1	H7	Output H select
C4	Output C select Input4	F2	Output F select Input2	H8	Output H select

## INTRODUCTION

The HSW88C 8x8 HDMI over CAT5 Matrix Switch with IR Pass-through provides the most flexible and cost effective solution in the market to route high definition video sources plus multi-channel (up to 7.1-channel) digital audio from any of the eight HDMI source devices to the remote displays at the same time. Through low cost Cat-5/5e/6 LAN cables, not only high quality video and audio can be transmitted to the display sites, but also users can switch among eight HDMI sources using the push button on the receiver or remote control. With single power design at the source site, each remote module is easily installed without power supply. Furthermore, the built-in IR extension allows users to control the HDMI source devices such as the Blu-ray Disc player or satellite receiver at display site!

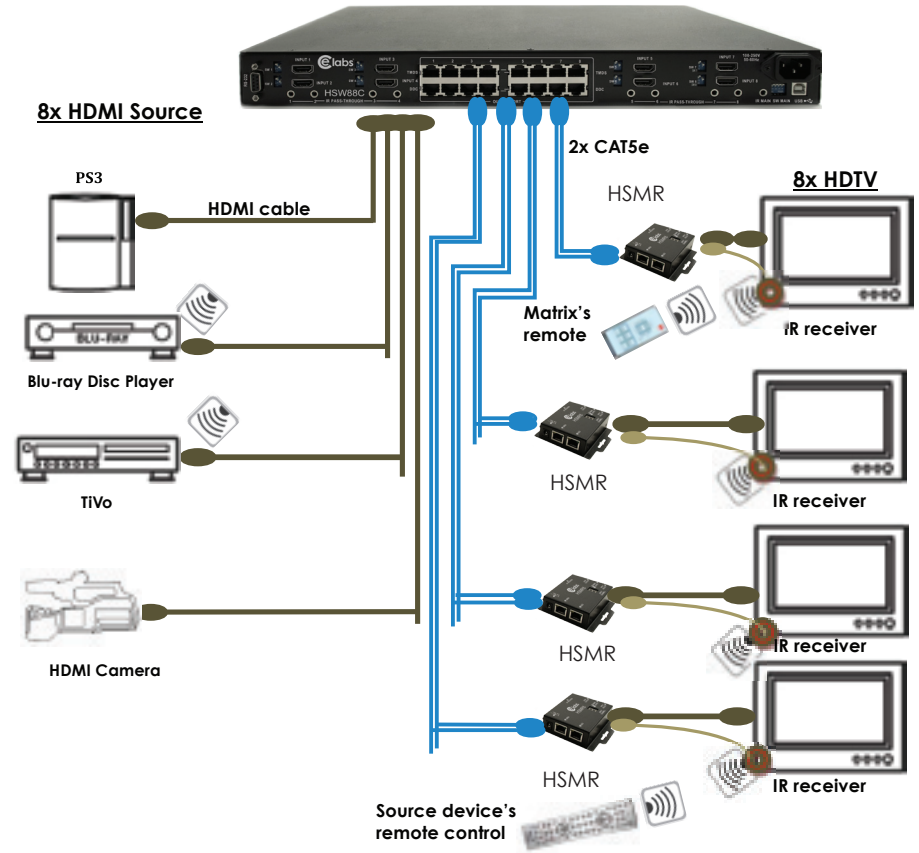

## FEATURES

- State-of-the-art Silicon Image (Founder of HDMI) chipset embedded for upmost compatibility and reliability
- HDMI 1.3c compliant
- HDCP compliant
- Allows any source to be displayed on multiple displays at the same time
- Allows any HDMI display to view any HDMI source at any time
- Supports 7.1 channel digital audio
- Supports default HDMI EDID and learns the EDID of displays
- The matrix switch master can switch every output channel to any HDMI input by push button, IR remote control, USB port or RS-232 control
- Allows control of local HDMI sources such as DVD and TiVo® by IR extender through control path at remote receiver
- Allows control of main matrix switch through control line at remote receiver
- Extends video signal up to 35m (115 feet) over CAT5e at 1080p and likely longer with better HDMI source device (such as PS3®), better grade HDMI display (such as Sony X-series HDTV®), and better quality solid CAT6 cable
- Easy installation with rack-mounting and wall-mounting designs for master and receiver respectively
- Fast response time – 2~5 seconds for channel switch



The length depends on the characteristics and quality of the cables. Higher resolutions and longer transmission distances require low skew cables (<25ns/100m) for best performance. Unshielded CAT6 with metal RJ-45 connectors is recommended

TiVo is a registered trademark of TiVo Inc.  
PS3 is a registered trademark of Sony Computer Entertainment.  
Sony X-series HDTV is a registered trademark of Sony Electronics Inc.

### 2. Setting button:

Press Get button to read back device ID.  
Press Set button to write device ID.

### 3. Linkage button:

Press Linkage button to read back all status.

### 4. Open/Close button:

Press this button to close or open COM port.



### 5. Mapping button:

Select All Output:

Select "set all output", then select the source on main menu. You can quickly set all outputs to the same source.

Unselect All Output:

Release output selection.

Select Input1~8-Output:

Select Input Source. Then select the output port icon.

For example:

Select input source 1. Then select output port one and two. The video and audio will be send to ports one and two.

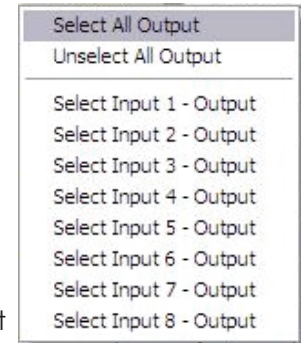

### 6. Fast Select button:

Press Fast select button. Quick setting.

Input one > Output Port one  
Input two > Output Port two  
.....

Press Fast select pull down menu.

Select Input Num-Output Num

Input source #1 > Output port #1  
Input source #2 > Output port #2  
.....

Select Input\* - All Output

Send the same source to all outputs.

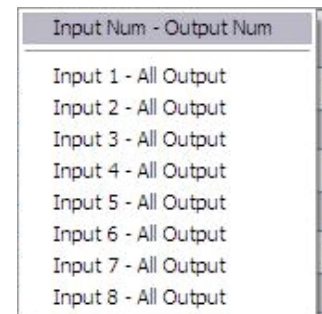

## Method C: Software Control Through RS-232 or USB

### Software Control Menu

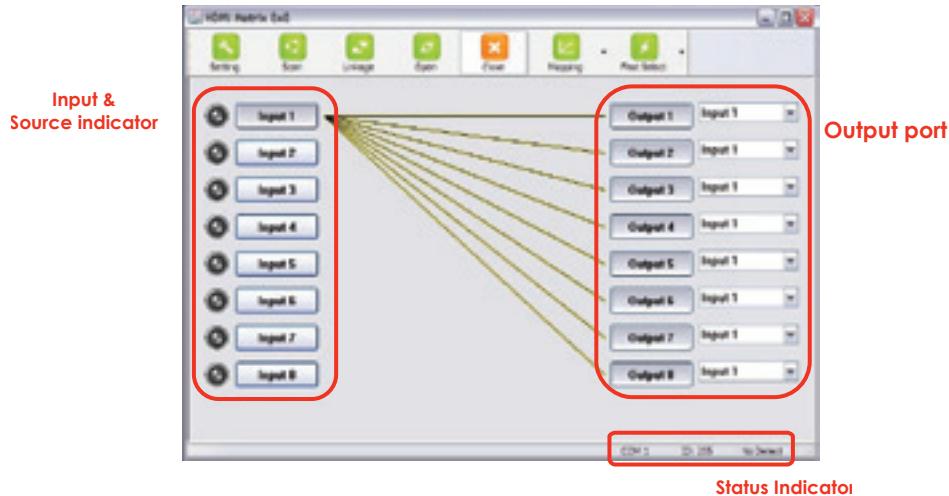

#### 1. Scan button:

##### Serial Port Scan:

Press Scan button, the computer will scan the all com port and display them.  
 Select the RS232 serial port connected to the Matrix switch.  
 And set device ID 255 is for all device.  
 Only the same device id or 255 can get the command you send.  
 Press OK. Get the new status from the Matrix switch (the port you select.)



## SPECIFICATIONS & PACKAGE CONTENTS

Model Name	HSW88C v1.3	
Technical	HSW88C	HSMR
Role of usage	8x8 true matrix Transmitter [TX]	Receiver [RX]
HDMI compliance	HDMI 1.3c	
HDCP compliance	Yes	
Video bandwidth	<b>[HSW88C v1.3]</b> – Single-link 225MHz [6.75Gpbs]	
Video support	480i / 480p / 720p / 1080i / 1080p60Hz	
Audio support	Surround sound (up to 7.1ch) or stereo digital audio	
HDMI over CAT5 transmission range	Full HD (1080p) – 115ft (35m) [CAT5e] / 130ft (40m) [CAT6] HD (720p/1080i) – 165ft [CAT5e] / 180ft [CAT6]	
HDMI equalization	N/A	8-level digital rotary control
TMDS signal	1.2 Volts [peak-to-peak]	
DDC signal	5 Volts [peak-to-peak, TTL]	
ESD protection	[1] Human body model — ±15kV [air-gap discharge] & ±8kV [contact discharge] [2] Core chipset — ±8kV	
PCB stack-up	4-layer board [impedance control — differential 100Ω; single 50Ω]	
Input	8x HDMI 1x RS-232 1x USB	1x RJ-45 [TMDS] 1x RJ-45 [DDC] 1x IR socket for IR receiver
Output	8x RJ-45 [TMDS] 8x RJ-45 [DDC] 9x IR socket for IR blaster	1x HDMI
HDMI Input selection	Push button / IR remote control / RS-232/USB	Push button / IR remote control
HDMI source control	Controllable via IR pass-through from IR receiver at RX to IR blaster at TX	
IR remote control	Electro-optical characteristics: $\tau = 25^\circ$ / Carrier frequency: 38kHz	
HDMI connector	Type A [19-pin female]	
RJ-45 connector	WE/SS 8P8C with 2 LED indicators [TMDS & DDC channels]	
RS-232 connector	DE-9 [9-pin D-sub female]	
USB connector <sup>3</sup>	Standard type-B [square shape]	
3.5mm connector	Earphone jack for IR blaster [IR Main] IR control on all source devices [IR PASS-THROUGH1~8] IR control on individual source device	Earphone jack for IR receiver [IR RECEIVER] Receives IR commands from remote control
DIP switch [HSW88C]	[SW1~SW8] 2-pin for EDID & audio mode [SW Main] 4-pin for operation & firmware update	



Mechanical		HSW88C	HSMR
Enclosure		Metal case	
Dimensions (L x W x H)	Model	440 x 290 x 44mm [1'5" x 11.4" x 1.7"]	85 x 90 x 25mm [3.3" x 3.5" x 1"]
	Package	528 x 398 x 130mm [1'9" x 1'4" x 5.1"]	90 x 85 x 25mm [3.5" x 3.3" x 1"]
	Carton	280 x 550 x 420mm [11" x 1'10" x 1'5"]	
Weight	Model	3250g [7.2 lbs]	180g [6.3oz]
	Package	7.1 kg [15.6 lbs]	
Mounting		1U rack-mount with ears	Wall-mount with screws
Power supply		AC Power 100-240V	Not necessarily required <sup>1</sup>
Power consumption		60 Watts [max]	1.5 Watt [max] (provided by MA-5188)
Operation temperature		0~40°C [32~104°F]	
Storage temperature		-20~60°C [-4~140°F]	
Relative humidity		20~90% RH [no condensation]	
Package Contents		1x HSW88C (matrix switch) 1x IR blaster <sup>2</sup> 2x 1U rack mounting-ear 1x IR remote controller <sup>2</sup> 1x User Manual	8x HSMR (HDMI receiver) 8x IR receiver 16x Wall-mounting screws 1x UL AC power cord



1. The HSMR has been tested extensively and found that it doesn't require external power supply. If in rare situation you find it cannot work with the HSW88C, please use any +5V power adapter to plug in the power jack and see if it can work. If not, please contact your technical support for further service.
2. Additional IR remote control and IR blaster cable can be purchased as optional accessories to control the HDMI sources located separately.
3. USB or RS-232 control must be connected either one at a time. Connecting both types of cables may cause command confusion.

## DISPLAY SIDE

### Method A: Push button for switching input channels

Press the INPUT SELECT push button to switch the input source on the respective output port connected to the matrix receiver in sequential order. The selected input source will be displayed on the LED of INPUT CHANNEL.

### Method B1: IR remote control for switching input channels

Please press F1 to F6, Enter (↵), and Exit (⏏) button to enter IR control mode and decide which input channel to be selected by pressing F1 to F6, Enter (↵), and Exit (⏏) button, and wait a few seconds for the input channel LED display to show the number of selected input source channel. Or you can use up (▲) and down (▼) button to enter IR control mode and select the input channel in ascending and descending order respectively.

Note:

F1	HDMI input source #1
F2	HDMI input source #2
F3	HDMI input source #3
F4	HDMI input source #4
F5	HDMI input source #5
F6	HDMI input source #6
Enter (↵)	HDMI input source #7
Exit (⏏)	HDMI input source #8
Up (▲)	Switch source in ascending order
Down (▼)	Switch source in descending order

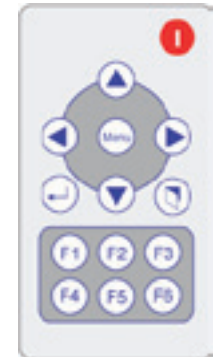

> If HSMR receives the IR command, the LED will flash. If not, try it again.

### Method B2: IR remote control for controlling the HDMI sources

Users can use the corresponding IR remote to control the HDMI source

## CHANNEL CONTROL

### SOURCE SIDE

#### Method A: Push Button

1. Use the switch button on output port to select which port to be changed.  
(+) increase (-) decrease
2. Push the switch button on Input channel. The source will be sequentially changed. After few seconds, the setting will be active.

#### Method B: IR Remote Control

a. Please press F1 to F8 Enter IR control mode and decide which output port to be controlled (see the table below), and wait a few seconds for the output port seven segment display to show the number of selected output port. Or you can use up (▲) and down (▼) button to enter IR control mode and select the output port in ascending and descending order respectively.

Note:

F1	HDMI output port #1
F2	HDMI output port #2
F3	HDMI output port #3
F4	HDMI output port #4
F5	HDMI output port #5
F6	HDMI output port #6
Enter (↵)	HDMI output port #7
Exit (⏏)	HDMI output port #8
Up (▲)	Switch output port in ascending order
Down (▼)	Switch output port in descending order

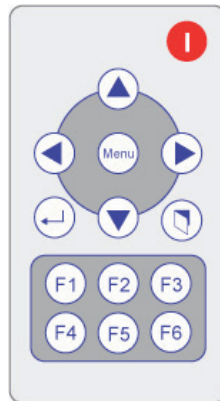

b. Use left (◀) or right (▶) button to select input source as indicated by the seven segment display on the front panel for the input channel. The setting will be active once the channel switch command is set after a couple seconds.

Note:

Right (▶) button to switch input source in ascending order (1, 2, 3, 4, 5, 6, 7, 8, 1, ...)  
Left (◀) button to switch input source in descending order (1, 8, 7, 6, 5, 4, 3, 2, 1, ...)

## PANEL DESCRIPTIONS

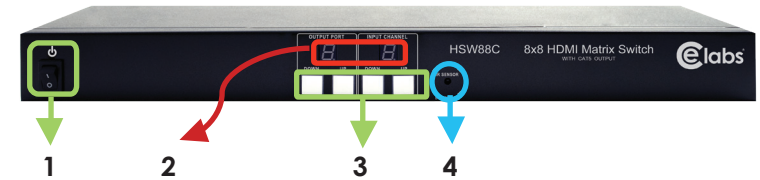

1. Power: Power control
2. Seven Segment LED Indicators: Control display
3. Front panel push buttons: Used to input source and display channel number
4. IR: IR receiver

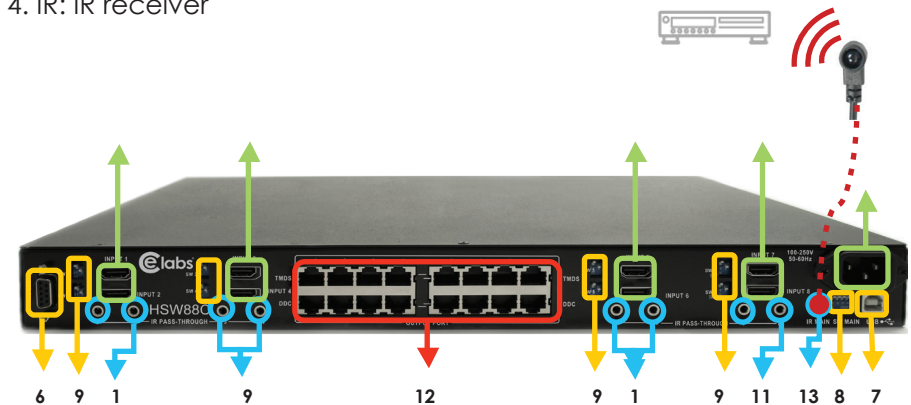

5. AC Power: 100-240V
6. RS-232: RS-232 control port
7. USB: USB control port
8. SW Main: DIP switches (see DIP Switch section in p.8)
9. SW 1-8: DIP switch (see DIP Switch section in p.8)
10. INPUT 1-8: HDMI inputs
11. IR PASS-THROUGH 1-8: 3.5mm IR blaster socket for individual HDMI source control
12. OUTPUT PORT 1-8: RJ-45 outputs for each output channel
13. IR Main: 3.5mm IR blaster socket for HDMI source control on all 8 inputs [default socket for IR blaster]

## HARDWARE INSTALLATION



1. +5V DC: Spare power jack for over 60m transmission when the RX may need external power to work\*.
2. TMDS: Plug in the CAT5 connected to the respective A/V SIGNAL port on the HSW88C
3. DDC: Plug in the CAT5 connected to the respective DDC port on the HSW88C
4. INPUT CHANNEL: Display the current selected HDMI source channel
5. INPUT SELECT: Push button for switching input source channel in sequential order
6. Signal Level 0-7: Adjust the 8-level equalization control for HDMI signals. 0 – 7 = strongest to weakest. It is recommended to switch from 7 to 0 to find the optimal visual experience.
7. HDMI Output: Connect to HDTV with a HDMI cable
8. IR RECEIVER: Plug in IR receiver

### HSW88C as Master

1. Connect all sources to HDMI Inputs on the 8x8 HDMI over CAT5 matrix master HSW88C
2. Connect each DDC output port on the HSW88C to respective DDC port on the remote receiver HSMR
3. Connect each TMDS output port on the HSW88C to respective TMDS input on the remote receiver HSMR
4. Connect IR blaster to the IR MAIN jack of HSW88C and direct the IR blaster to the built-in IR receiver of the sources
5. Connect the +5V 6A DC power supply to the HSW88C
6. Power on all HDMI sources
7. Power on the HSW88C

### HSMR as receiver

1. Connect each HDMI output to HDMI displays
2. Connect each DDC output port on the HSW88C to respective DDC port on the remote receiver HSMR
3. Connect each TMDS output port on the HSW88C to respective TMDS input on the remote receiver HSMR
4. Connect IR receiver and place the IR receiver at the appropriate position that can receive the IR command signals sent from the users
5. Dial the 8-level rotary control switch to adjust the HDMI signal level until the picture and sound are clear

**i** The HSMR has been tested extensively and found that it doesn't require external power supply. If in rare situation you find it cannot work with the HSW88C, please use any +5V power adapter to plug in the power jack and see if it can work. If not, please contact your technical support for further service.



## Definition of IR Earphone Jack



**i** The IR extension cables are standard market configuration. You can buy From CE labs if necessary for replacement use.

## Supported IR Data Format

Data Format	Suitable	Not Recommended
NEC	<input checked="" type="checkbox"/>	
RC5	<input checked="" type="checkbox"/>	
TOSHIBA MICOM CODE	<input checked="" type="checkbox"/>	
GRUNDIG CODE	<input checked="" type="checkbox"/>	
SONY 12 BIT CODE	<input checked="" type="checkbox"/>	
SONY 15 BIT CODE	<input checked="" type="checkbox"/>	
SONY 20 BIT CODE	<input checked="" type="checkbox"/>	
RCA CODE		<input checked="" type="checkbox"/>
RCM CODE		<input checked="" type="checkbox"/>
MATSUSHITA CODE		<input checked="" type="checkbox"/>
MITSUBISHI CODE	<input checked="" type="checkbox"/>	
ZENITH CODE	<input checked="" type="checkbox"/>	
JVC CODE	<input checked="" type="checkbox"/>	
M50560-001P	<input checked="" type="checkbox"/>	
MN6125H	<input checked="" type="checkbox"/>	
MN6125L	<input checked="" type="checkbox"/>	
MN6014_C5D7	<input checked="" type="checkbox"/>	
MN6014-C6D6	<input checked="" type="checkbox"/>	
MC14457P	<input checked="" type="checkbox"/>	
LC7464(AHEA)	<input checked="" type="checkbox"/>	
GEMINI_CM	<input checked="" type="checkbox"/>	

## DIP SWITCH

### SW1-SW8 for EDID/Audio

DIP Switch Position		Video	Audio	Description
Pin#1	Pin#2			
OFF [▲]	OFF [▲]	Up to 1080p	Stereo <sup>1</sup>	<b>Default Mode<sup>2</sup></b> – Up to 1080p & stereo audio output for most HDTVs
OFF [▲]	ON [▼]	Up to 720p / 1080i	Stereo	<b>Safe Mode<sup>3</sup></b> – Enforce the system output at 720p/1080i video and stereo audio for basic compatibility among HDTVs
ON [▼]	OFF [▲]	Bypass <sup>4</sup>	Bypass <sup>4</sup>	<b>EDID Learning Mode<sup>5</sup></b> – for learning EDID from the display while playing any received HDMI audio format
ON [▼]	ON [▼]	Bypass	Stereo	<b>EDID Learning &amp; Stereo Mode<sup>5</sup></b> – for learning EDID from the display while enforcing stereo output if any HDTV cannot play surround sound normally



Note:

1. If the HDTV shows video but without audio, please try to set audio mode to stereo.
2. Factory default setting of [SW1]-[SW8] is pin#1-OFF[▲] & pin#2- OFF[▲] for 1080p with stereo.
3. If you encounter any unsolved audio/video output problem during system installation, please turn any [SW1]-[SW8] to pin#1-OFF[▲] & pin#2-ON[▼] for safe mode to enforce the most compatible 720p stereo output for system check. However, the safe mode cannot be initiated if your HDMI source is set to enforce 1080p output. In this case, please reconfigure your HDMI source to all resolution output for troubleshooting.
4. Bypass means the matrix will maintain playing the original format of HDMI signals in video and perhaps audio. By setting at this mode, the users may encounter compatibility issue among different kinds of HDMI sources and displays. If you cannot get the audio and/or video output normally at the system installation, please change the DIP switch setting to default mode or even safe mode to verify the functionality of the device.
5. To learn the EDID of HDMI display for respective HDMI source devices, please see the [EDID Learning] section in the next page for more detail information.

## SW Main for firmware update (for technical support only)

DIP Switch Position		Pin#1	Pin#2	Pin#3	Pin#4
Normal Operation Mode [via RS-232 port] <sup>6</sup>		OFF[▲]	OFF[▲]	OFF[▲]	OFF[▲]
Normal Operation Mode [via USB port] <sup>7</sup>		OFF[▲]	OFF[▲]	OFF[▲]	ON[▼]
Firmware Mode <sup>8</sup>	Update	Block A [main]	ON[▼]	OFF[▲]	OFF[▲]
		Block B [remote]	ON[▼]	OFF[▲]	ON[▼]
		Block C [HDMI]	ON[▼]	ON[▼]	OFF[▲]



### Note

6. Factory default for SW Main is pin#1-OFF[▲], pin#2-OFF[▲], pin#3- OFF[▲], & pin#4-OFF[▲]. PLEASE MAINTAIN THIS SETTING AT ANYTIME FOR REGULAR USE VIA RS-232 CONTROL!
7. Factory default for SW Main is pin#1-OFF[▲], pin#2-OFF[▲], pin#3- OFF[▲], & pin#4- ON[▼]. PLEASE MAINTAIN THIS SETTING AT ANYTIME FOR REGULAR USE VIA USB CONTROL!
8. Sequence for firmware update

**WARNING!** [Firmware update only can be done via RS-232 port and connection to PC set at COM1]

1. Power off the HSW88C. Execute the firmware update program on your PC via COM1 port connection to the RS-232 port of the HSW88C.
2. Set the pin#1 of [SW Main] at ON[▼] for firmware update mode.
3. Set pin#2 and pin#3 at respective positions to assign which Block to be updated.
4. Power on the HSW88C. The firmware update program should begin this update sequence automatically. If not, please check the RS-232 connection status between PC and HSW88C.
5. After the OK message shows up to indicate the firmware update sequence for designated Block is complete, please turn off the HSW88C.
6. Repeat step 3 ~ step6 if you want to update the firmware of the remaining Blocks.
7. Set the [SW Main] switch position to Normal Operation Mode.
8. Power on the HSW88C

## IR CONTROL PATH

### IR Sockets



#### HSW88C

IR Main: The default location for IR blaster to transmit all IR command signals received from any of the eight remote receivers to all of the HDMI sources.

IR Pass-Through 1-8: IR blaster connected here can only transmit IR command signals from the remote receivers that are setting at respective input channel from 1 to 8.

#### HSMR

IR Receiver: IR receiver connected here can receive all IR command signals from the IR remote controls of HSW88C and all other HDMI source devices.

## Free Manuals Download Website

<http://myh66.com>

<http://usermanuals.us>

<http://www.somanuals.com>

<http://www.4manuals.cc>

<http://www.manual-lib.com>

<http://www.404manual.com>

<http://www.luxmanual.com>

<http://aubethermostatmanual.com>

Golf course search by state

<http://golfingnear.com>

Email search by domain

<http://emailbydomain.com>

Auto manuals search

<http://auto.somanuals.com>

TV manuals search

<http://tv.somanuals.com>