



Installation, Start-Up and Service Instructions

CONTENTS

	Page
SAFETY CONSIDERATIONS	1
INSTALLATION	1-18
Step 1 — Provide Unit Support	1
• ROOF CURB	
• ALTERNATE UNIT SUPPORT	
Step 2 — Rig and Place Unit	1
• POSITIONING	
• ROOF MOUNT	
Step 3 — Field Fabricate Ductwork	7
Step 4 — Make Unit Duct Connections	7
Step 5 — Trap Condensate Drain	7
Step 6 — Make Electrical Connections	8
• FIELD POWER SUPPLY	
• FIELD CONTROL WIRING	
• OPTIONAL NON-FUSED DISCONNECT	
• OPTIONAL CONVENIENCE OUTLET	
Step 7 — Make Outdoor-Air Inlet Adjustments	11
• MANUAL OUTDOOR-AIR DAMPER	
• OPTIONAL ECONOMISER	
Step 8 — Install Outdoor-Air Hood	12
Step 9 — Install All Accessories	15
• MOTORMASTER® I CONTROL INSTALLATION	
• MOTORMASTER III CONTROL INSTALLATION	
Step 10 — Install Humidistat for Optional MoistureMiser Dehumidification Package	16
START-UP	18-24
SERVICE	24-31
TROUBLESHOOTING	32,33
START-UP CHECKLIST	CL-1

SAFETY CONSIDERATIONS

Installation and servicing air-conditioning equipment can be hazardous due to system pressure and electrical components. Only trained and qualified service personnel should install, repair, or service air-conditioning equipment.

Untrained personnel can perform basic maintenance functions of cleaning coils and filters and replacing filters. All other operations should be performed by trained service personnel. When working on air-conditioning equipment, observe precautions in the literature, tags and labels attached to the unit, and other safety precautions that may apply.

Follow all safety codes. Wear safety glasses and work gloves. Use quenching cloth for unbrazing operations. Have fire extinguishers available for all brazing operations.

▲ WARNING

Before performing service or maintenance operations on unit, turn off main power switch to unit. Electrical shock could cause personal injury.

IMPORTANT: Units have high ambient operating limits. If limits are exceeded, the unit will automatically lock the compressor out of operation. Manual reset will be required to restart the compressor.

INSTALLATION

Step 1 — Provide Unit Support

ROOF CURB — Assemble and install accessory roof curb or horizontal adapter roof curb in accordance with instructions shipped with the curb or horizontal adapter. Accessory roof curb and horizontal adapter roof curb and information required to field fabricate a roof curb or horizontal adapter roof curb are shown in Fig. 1 and 2. Install insulation, cant strips, roofing, and counter flashing as shown. Ductwork can be secured to roof curb before unit is set in place.

IMPORTANT: The gasketing of the unit to the roof curb or adapter roof curb is critical for a leak-proof seal. Install gasket supplied with the roof curb or adapter roof curb as shown in Fig. 1. Improperly applied gasket can result in air leaks and poor unit performance.

Curb or adapter roof curb should be level. This is necessary to permit unit drain to function properly. Unit leveling tolerance is $\pm 1/16$ in. per linear ft in any direction. Refer to Accessory Roof Curb or Horizontal Adapter Roof Curb Installation Instructions for additional information as required.

ALTERNATE UNIT SUPPORT — When the curb or adapter cannot be used, support unit with sleepers using unit curb or adapter support area. If sleepers cannot be used, support long sides of unit with a minimum of 3 equally spaced 4-in. x 4-in. pads on each side.

Step 2 — Rig and Place Unit — Inspect unit for transportation damage. File any claim with transportation agency. Keep unit upright, and do not drop. Use spreader bars over unit to prevent sling or cable damage. Rollers may be used to move unit across a roof. Level by using unit frame as a reference; leveling tolerance is $\pm 1/16$ in. per linear ft in any direction. See Fig. 3 for additional information. Unit weight is shown in Table 1.

Four lifting holes are provided in ends of unit base rails as shown in Fig. 3. Refer to rigging instructions on unit.

POSITIONING — Provide clearance around and above unit for airflow, safety, and service access (Fig. 4 and 5).

Do not install unit in an indoor location. Do not locate air inlets near exhaust vents or other sources of contaminated air.

Although unit is weatherproof, guard against water from higher level runoff and overhangs.

ROOF MOUNT — Check building codes for weight distribution requirements.

PKG. NO. REF.	CURB HEIGHT	DESCRIPTION
CRRFCURB010A00	1'-2" (305)	Standard Curb 14" High
CRRFCURB011A00	2'-0" (610)	Standard Curb for Units Requiring High Installation
CRRFCURB012A00	2'-0" (610)	Side Supply and Return Curb for High Installation

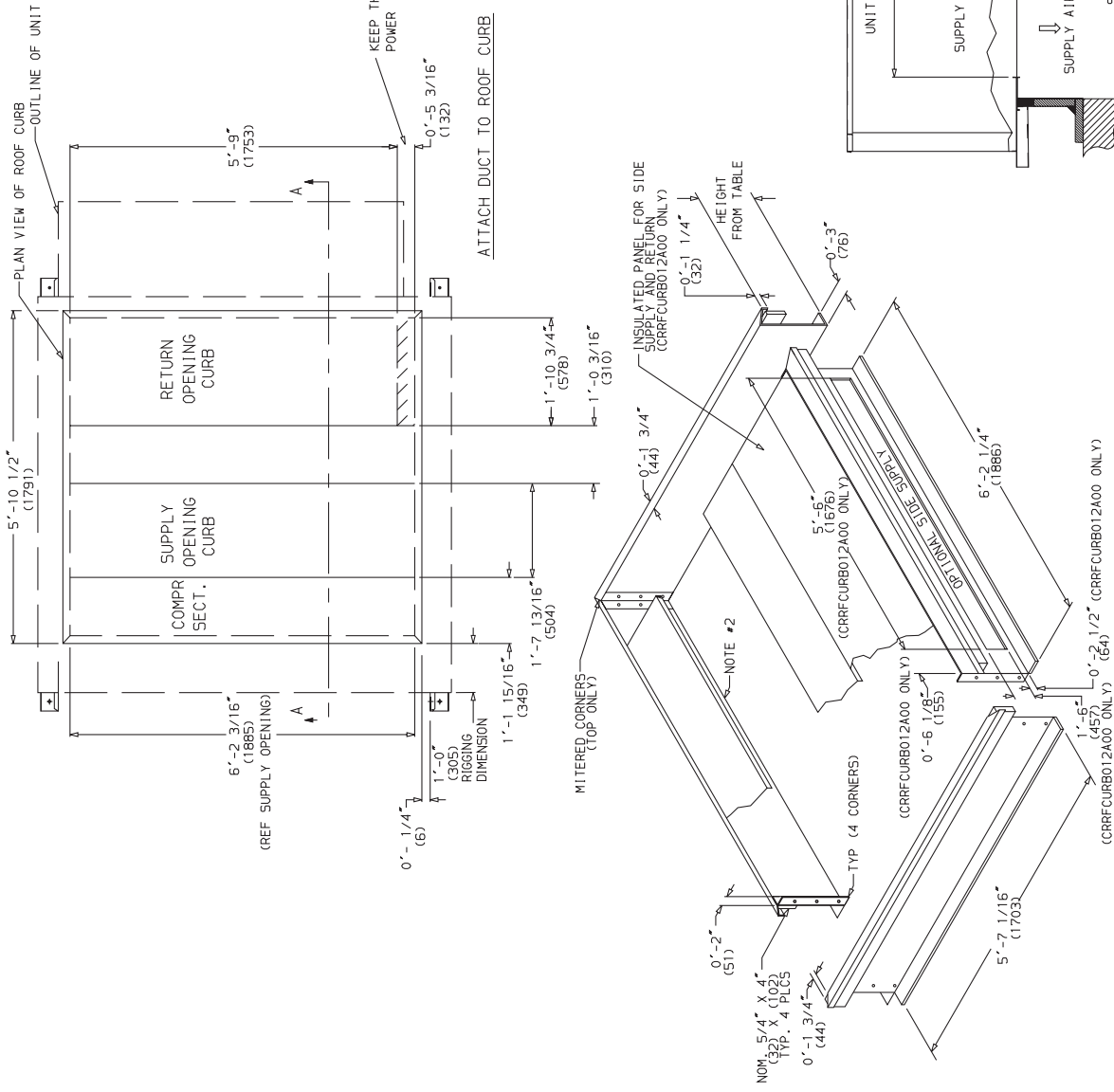

NOTES:

1. Roof curb accessory is shipped disassembled.
2. Insulated panels: 1" thick neoprene coated 1 1/2 lb density.
3. Dimensions in () are in millimeters.
4. Direction of airflow.
5. Roof curb: 16 ga. (VA03-56) stl.
6. **A 90 degree elbow must be installed on the supply ductwork below the unit discharge for units equipped with electric heaters.**

NOTE: To prevent the hazard of stagnant water build-up in the drain pan of the indoor section, unit can only be pitched as shown.

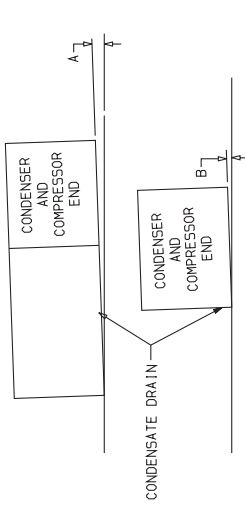

DIMENSIONS* (degrees and inches)

UNIT	A		B	
	Deg.	in.	Deg.	in.
ALL	.28	.45	.28	.43

UNIT LEVELING TOLERANCES
*From edge of unit to horizontal.

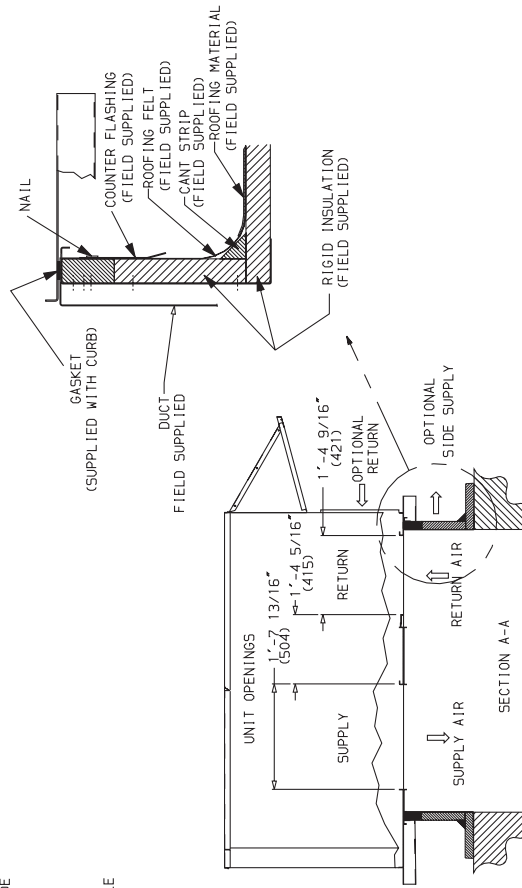
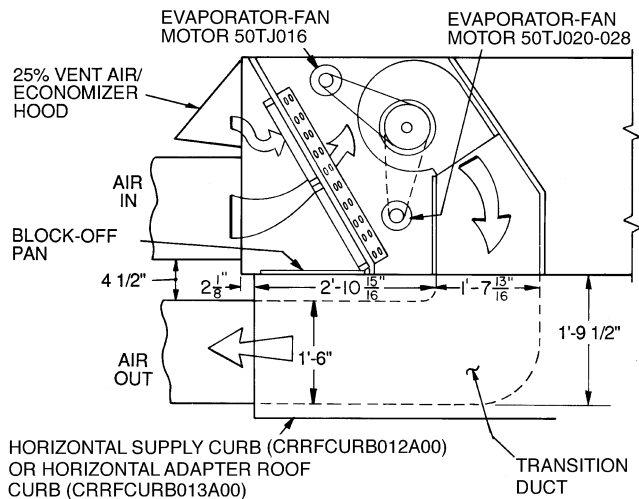
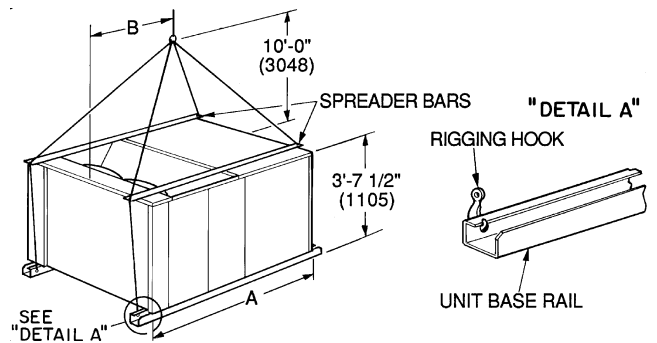

Fig. 1 — Roof Curb Details



NOTE: For preassembled horizontal adapter roof curb part no. CRRFCURB013A00, the accessory kit includes a factory-designed, high-static, transition duct. For horizontal curb part no. CRRFCURB012A00, a field-supplied transition duct is required.

Fig. 2 — Horizontal Adapter Roof Curb and Roof Curb



UNIT 50TJ	MAXIMUM SHIPPING WEIGHT		DIMENSIONS			
			A		B	
	Lb	Kg	Ft-in.	mm	Ft-in.	mm
016	1550	703	6-11 1/2	2121	4- 0	1219
020	1650	748	6-11 1/2	2121	3-10	1168
024	1700	771	6-11 1/2	2121	3- 7	1092
028	1850	839	6-11 1/2	2121	3- 5	1041

NOTES:

1. Dimensions in () are in millimeters.
2. Refer to Fig. 4 and 5 for unit operating weights.
3. Remove boards at ends of unit and runners prior to rigging.
4. Rig by inserting hooks into unit base rails as shown. Use corner post from packaging to protect coil from damage. Use bumper boards for spreader bars.
5. Weights do not include optional EconoMi\$er. See Fig. 4 and 5 for EconoMi\$er weight. See Table 1 for MoistureMiser weight.
6. Weights given are for aluminum evaporator and condenser coil plate fins.

⚠ CAUTION

All panels must be in place when rigging.

Fig. 3 — Rigging Details

UNIT	STD UNIT WEIGHT		ECONOMISER WEIGHT		CORNER (A)		CORNER (B)		CORNER (C)		CORNER (D)		DIM B		DIM C			
	Lb	Kg	Lb	Kg	Lb	Kg	Lb	Kg	Lb	Kg	Lb	Kg	mm	mm	mm	mm		
50TJ016	1550	703	80	36.3	391	177	385	166	384	174	410	186	3-5	1041	3-6	1067	1-10	559
50TJ020	1650	748	80	36.3	399	181	384	174	402	182	439	199	3-4	1016	3-6	1067	1-8	508

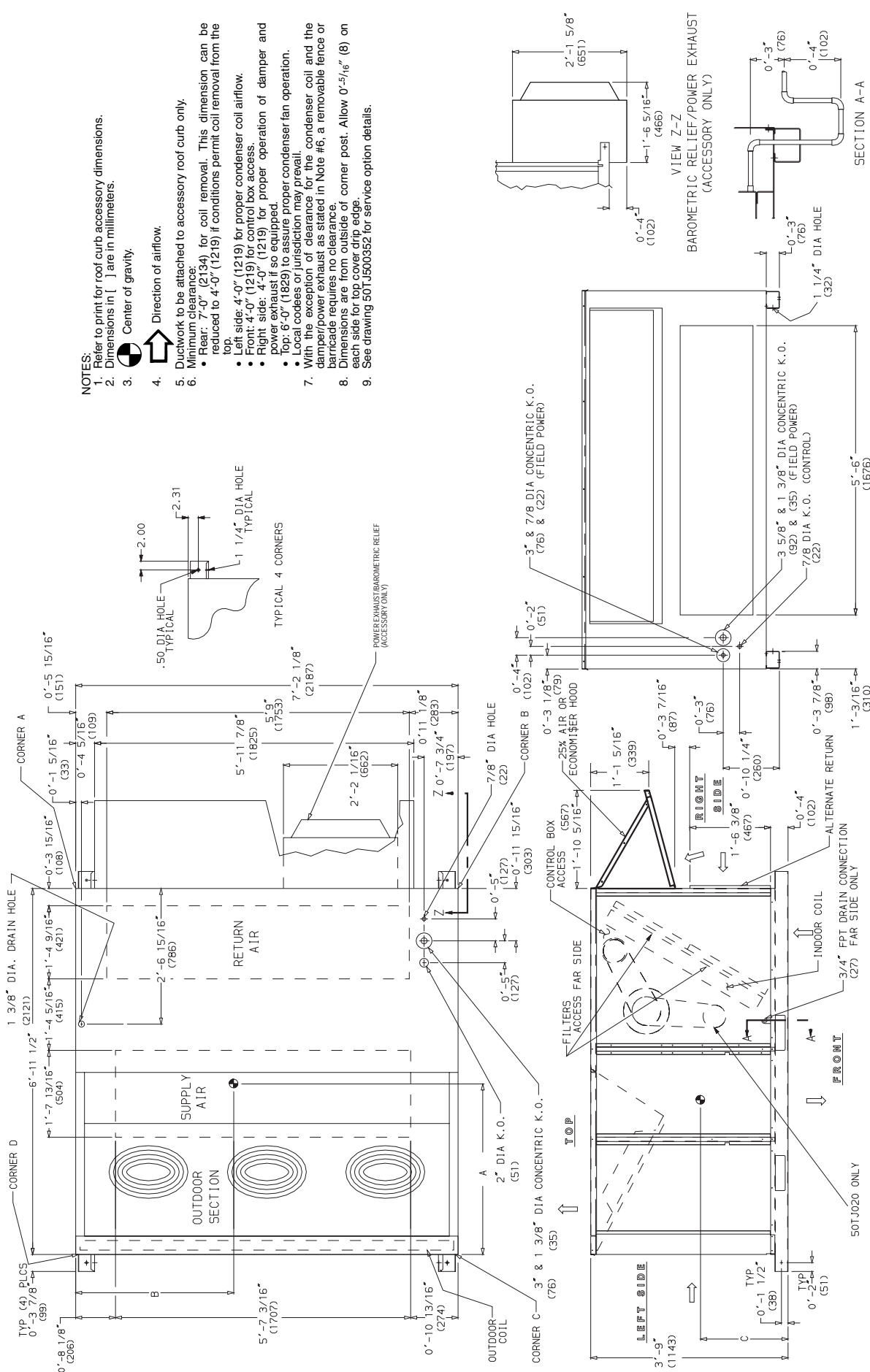



- NOTES:**
- Refer to print for roof curb accessory dimensions.
 - Dimensions in [] are in millimeters.
 - Center of gravity.
 - Direction of airflow.
 - Ductwork to be attached to accessory roof curb only.
 - Minimum clearance:
 - Rear: 7'-0" (2134) for coil removal. This dimension can be reduced to 4'-0" (1219) if conditions permit coil removal from the top.
 - Left side: 4'-0" (1219) for proper condenser coil airflow.
 - Front: 4'-0" (1219) for control box access.
 - Right side: 4'-0" (1219) for proper operation of damper and power exhaust if so equipped.
 - Top: 6'-0" (1829) to assure proper condenser fan operation.
 - Local codes or jurisdiction may prevail. With the exception of clearance for the condenser coil and the damper/power exhaust as stated in Note #6, a removable fence or barricade requires no clearance.
 - Dimensions are from outside of corner post. Allow 0'-5/16" (8) on each side for top cover drip edge.
 - See drawing 50TJ500352 for service option details.

Fig. 4 — Base Unit Dimensions, 50TJ016,020

UNIT	STD UNIT WEIGHT		ECONOMISER WEIGHT		CORNER (A)		CORNER (B)		CORNER (C)		CORNER (D)		DIM A		DIM B		DIM C	
	Lb	Kg	Lb	Kg	Lb	Kg	Lb	Kg	Lb	Kg	Lb	Kg	Lb	Kg	Ft-in.	mm	Ft-in.	mm
50TJ024	1700	771	80	36.3	419	190	394	179	425	193	463	210	3-4	1016	3-5	1041	1-8	508
50TJ028	1850	839	80	36.3	428	194	412	187	511	232	499	226	3-2	965	3-7	1092	1-8	508

NOTES:

- Refer to print for roof curb accessory dimensions.
- Dimensions in [] are in millimeters.
-  Center of gravity.
-  Direction of airflow.
- Ductwork to be attached to accessory roof curb only.
- Minimum clearances for coil removal. This dimension can be reduced to 4'-0" (1219) if conditions permit coil removal from the top.
 - Front: 4'-0" (1219) control box access.
 - Right side: 4'-0" (1219) for proper operation of damper and powerstat if so equipped.
 - Top: 6'-0" (1829) to assure proper condenser fan operation.
- Local codes or jurisdiction may prevail.
 - With the exception or clearance for the condenser coil and the damper/power exhaust as stated in Note #6, a removable fence or barricade requires no clearance.
- Dimensions are from outside of corner post. Allow 0'-5/16" (8) on each side for top edge of corner post.
- See drawing 50TJ500352 for service option details.

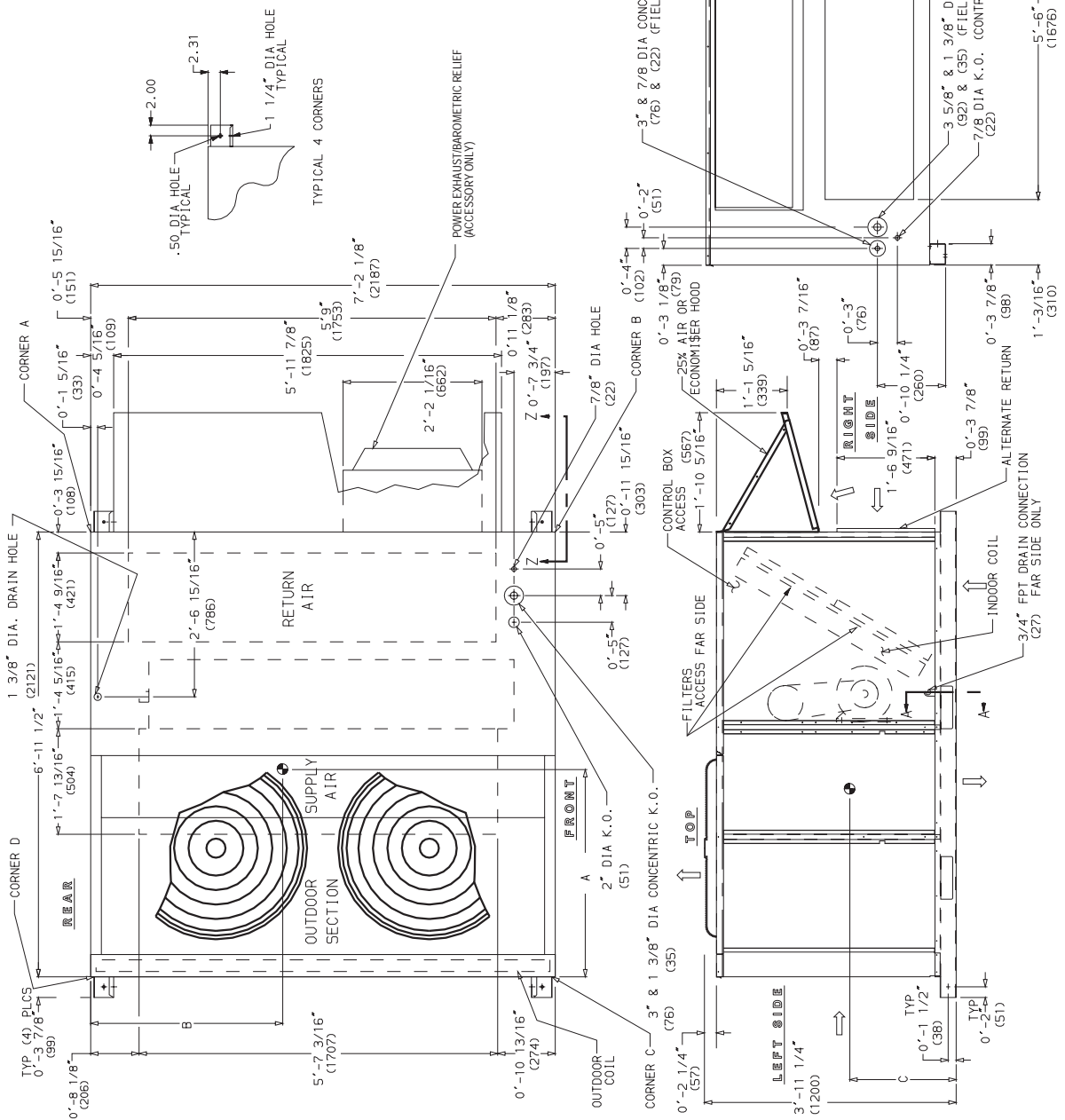

Fig. 5 — Base Unit Dimensions, 50TJ024,028

Table 1 — Physical Data

UNIT 50TJ	016		020	024	028
	208/230, 460 v	575 v			
NOMINAL CAPACITY (tons)	15		18	20	25
OPERATING WEIGHT	1550		1650	1700	1850
EconoMiser	80		80	80	80
MoistureMiser Dehumidification Package	40		40	40	40
COMPRESSOR/MANUFACTURER	Scroll, Copeland				
Quantity...Model (Ckt 1, Ckt 2)	2...ZR94KC		1...ZR108KC, 1...ZR94KC	1...ZR125KC, 1...ZR108KC	1...ZR16M3, 1...ZR125KC
Capacity Stages (%)	50, 50		55, 45	55, 45	60, 40
Number of Refrigerant Circuits	2		2	2	2
Oil (oz) (Ckt 1, Ckt 2)	81, 81		106, 81	106, 106	136, 106
REFRIGERANT TYPE	R-22				
Expansion Device	TXV				
Operating Charge (lb-oz)	10-10		15-5	16-0	20-13
Circuit 1*	10-10		12-3	13-6	13- 0
CONDENSER COIL	Cross-Hatched 3/8-in. Copper Tubes, Aluminum Lanced, Aluminum Pre-Coated, or Copper Plate Fins				
Rows...Fins/in.	2...17		3...15	3...15	4...15
Total Face Area (sq ft)	21.7		21.7	21.7	21.7
CONDENSER FAN	Propeller Type				
Nominal Cfm	10,500		10,500	14,200	14,200
Quantity...Diameter (in.)	3...22		3...22	2...30	2...30
Motor Hp...Rpm	1/2...1050		1/2...1050	1...1075	1...1075
Watts Input (Total)	1100		1100	3400	3400
EVAPORATOR COIL	Cross-Hatched 3/8-in. Copper Tubes, Aluminum Lanced or Copper Plate Fins, Face Split				
Rows...Fins/in.	2...17		3...15	3...15	4...15
Total Face Area (sq ft)	17.5		17.5	17.5	17.5
EVAPORATOR FAN	Centrifugal Type				
Quantity...Size (in.)	2...10 x 10	2...10 x 10	2...12 x 12	2...12 x 12	2...12 x 12
Type Drive	Belt	Belt	Belt	Belt	Belt
Nominal Cfm	6000	6000	7200	8000	10,000
Motor Hp	3.7	3.0	5	7.5	10
Motor Nominal Rpm	1725	1725	1745	1745	1740
Maximum Continuous Bhp	4.25	3.45	5.90	8.7 [208/230, 575 v]	10.2 [208/230, 575 v]
Motor Frame Size	56H	56H	184T	213T	215T
Nominal Rpm High/Low	—	—	—	—	—
Fan r/s Range	Low-Medium Static 891-1179 High Static 1227-1550	1159-1429	910-1095 1069-1287	1002-1225 1193-1458	1066-1283 1332-1550
Motor Bearing Type	Ball	Ball	Ball	Ball	Ball
Maximum Allowable Rpm	1550	1550	1550	1550	1550
Motor Pulley Pitch Diameter	Low-Medium Static 3.1/4.1 High Static 3.7/4.7	4.3/5.3	4.9/5.9 4.9/5.9	5.4/6.6 5.4/6.6	4.9/5.9 4.9/5.9
Nominal Motor Shaft Diameter (in.)	7/8	7/8	1 1/8	1 3/8	1 3/8
Fan Pulley Pitch Diameter (in.)	Low-Medium Static 6.0 High Static 5.2	6.4	8.0	9.4 7.9	8.0 6.4
Nominal Fan Shaft Diameter (in.)	1 3/16	1 3/16	1 7/16	1 7/16	1 7/16
Belt, Quantity...Type...Length (in.)	Low-Medium Static 1...BX...42 High Static 1...BX...42	1...BX...45	1...BX...50 1...BX...48	1...BX...53 1...BX...50	2...BX...50 2...BX...47
Pulley Center Line Distance (in.)	13.5-15.5	13.5-15.5	13.3-14.8	14.6-15.4	14.6-15.4
Speed Change per Full Turn of Movable Pulley Flange (rpm)	Low-Medium Static 48 High Static 55	44	37 34	37 44	36 45
Movable Pulley Maximum Full Turns From Closed Position	6	6	6	6	6
Factory Speed	3.5	3.5	3.5	3.5	3.5
Factory Speed Setting (rpm)	Low-Medium Static 1035 High Static 1389	1296	1002 1178	1120 1328	1182 1470
Fan Shaft Diameter at Pulley (in.)	1 3/16	1 3/16	1 7/16	1 7/16	1 7/16
HIGH-PRESSURE SWITCH (psig)	426				
Cutout	320				
Reset (Auto)					
LOW-PRESSURE SWITCH (psig)	27				
Cutout	44				
Reset (Auto)					
FREEZE PROTECTION THERMOSTAT (F)	30 ± 5				
Opens	45 ± 5				
Closes					
OUTDOOR-AIR INLET SCREENS	Cleanable				
Quantity...Size (in.)	2...20 x 25 x 1 1...20 x 20 x 1				
RETURN-AIR FILTERS	Throwaway†				
Quantity...Size (in.)	4...20 x 20 x 2 4...16 x 20 x 2				
POWER EXHAUST	1/2 Hp, 208/230-460 v Motor Direct Drive, Propeller-Fan (Factory-Wired for 460 v)				

LEGEND

Bhp — Brake Horsepower
TXV — Thermostatic Expansion Valve

*Circuit 1 uses the lower portion of condenser coil and lower portion of evaporator coils; and Circuit 2 uses the upper portion of both coils.

†The 50TJ028 units requires 2-in. industrial-grade filters capable of handling face velocities of up to 625 ft/min (such as American Air Filter no. 5700 or equivalent).

NOTE: The 50TJ016-028 units have a low-pressure switch (standard) located on the suction side.

Step 3 — Field Fabricate Ductwork — Secure all ducts to building structure. Use flexible duct connectors between unit and ducts as required. Insulate and weatherproof all external ductwork, joints, and roof openings with counter flashing and mastic in accordance with applicable codes.

Ducts passing through an unconditioned space must be insulated and covered with a vapor barrier.

The 50TJ units with electric heat require a 1-in. clearance for the first 24 in. of ductwork.

Outlet grilles must not lie directly below unit discharge.

NOTE: A 90-degree elbow must be provided in the ductwork to comply with UL (Underwriters' Laboratories) codes for use with electric heat.

⚠ WARNING

For vertical supply and return units, tools or parts could drop into ductwork and cause an injury. Install a 90 degree turn in the return ductwork between the unit and the conditioned space. If a 90 degree elbow cannot be installed, then a grille of sufficient strength and density should be installed to prevent objects from falling into the conditioned space. Due to electric heater, supply duct will require 90 degree elbow.

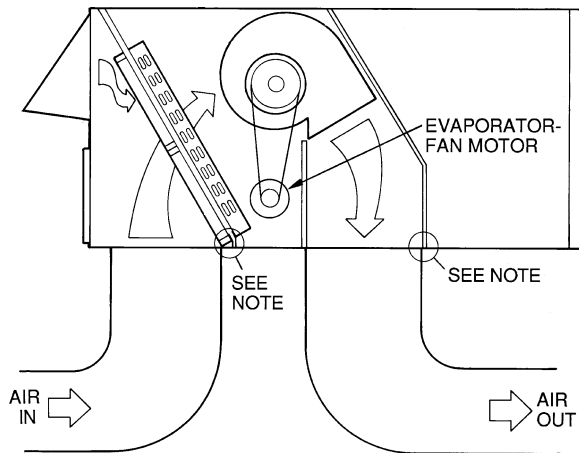

NOTE: Do not drill in this area; damage to basepan may result in water leak.

Fig. 6 — Air Distribution — Thru-the-Bottom (50TJ020-028 Shown)

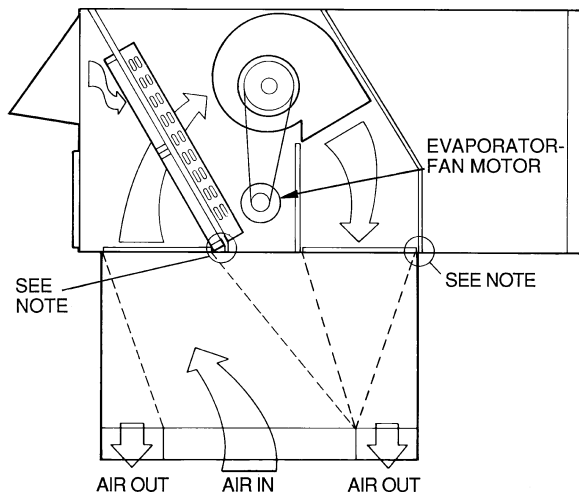

NOTE: Do not drill in this area; damage to basepan may result in water leak.

Fig. 7 — Concentric Duct Air Distribution (50TJ020-028 Shown)

Step 4 — Make Unit Duct Connections — Unit is shipped for through-the-bottom duct connections. Ductwork openings are shown in Fig. 6. Field-fabricated concentric ductwork may be connected as shown in Fig. 7 and 8. Attach all ductwork to roof curb and roof curb basepans. Refer to installation instructions shipped with accessory roof curb for more information.

Step 5 — Trap Condensate Drain — See Fig. 4, 5, and 9 for drain location. Plug is provided in drain hole and must be removed when unit is operating. One 3/4-in. half-coupling is provided inside unit evaporator section for condensate drain connection. An 8 1/2 in. x 3/4-in. diameter nipple and a 2-in. x 3/4-in. diameter pipe nipple are coupled to standard 3/4-in. diameter elbows to provide a straight path down through holes in unit base rails (see Fig. 10). A trap at least 4-in. deep must be used.

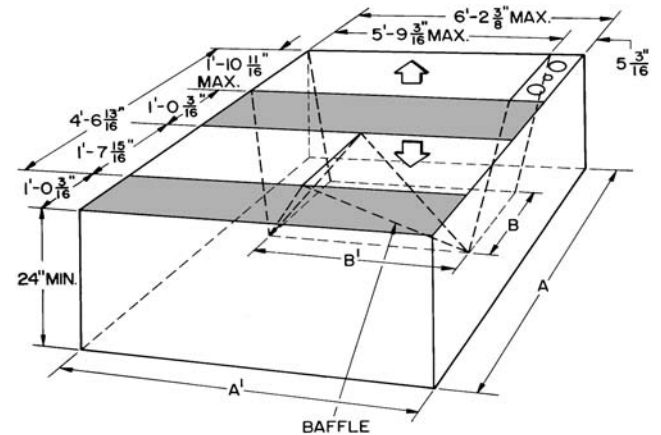

Shaded area indicates block-off panels.

NOTE: Dimensions A, A', and B, B' are obtained from field-supplied ceiling diffuser.

Fig. 8 — Concentric Duct Details

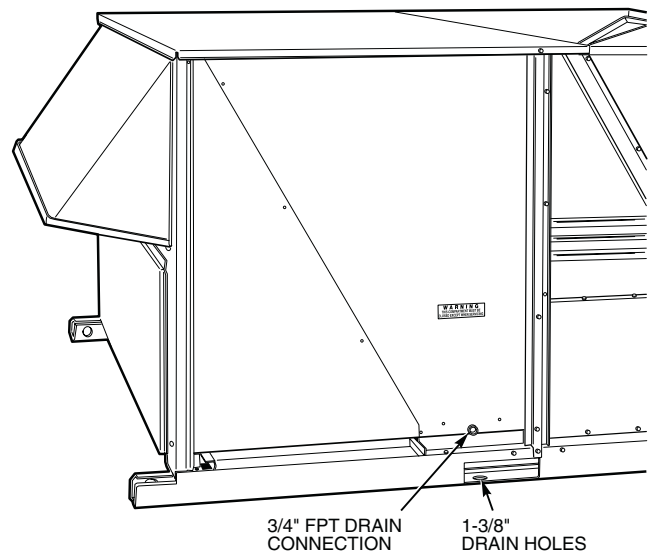

Fig. 9 — Condensate Drain Details (50TJ016,020 Shown)

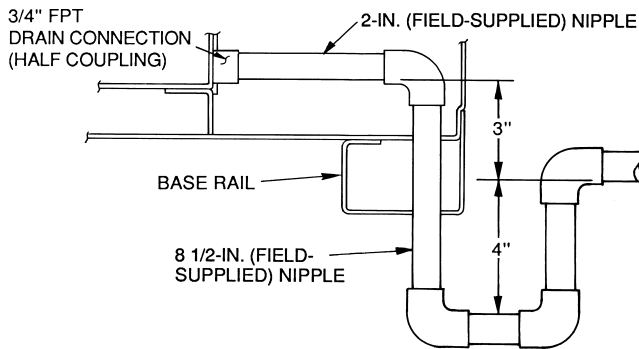

Fig. 10 — Make Electrical Connections

Step 6 — Make Electrical Connections

FIELD POWER SUPPLY — Unit is factory wired for voltage shown on nameplate.

When installing units, provide a disconnect, per NEC (National Electrical Code) requirements, of adequate size (Table 2).

All field wiring must comply with NEC and local requirements.

Route power lines through control box access panel or unit basepan (Fig. 4 and 5) to connections as shown on unit wiring diagram and Fig. 11.

Operating voltage to compressor must be within voltage range indicated on unit nameplate. On 3-phase units, voltages between phases must be balanced within 2% and the current must be balanced within 10%.

⚠ CAUTION

The correct power phasing is critical in the operation of the scroll compressors. An incorrect phasing will cause the compressor to rotate in the wrong direction. This may lead to premature compressor failure.

Use the following formula to determine the percentage of voltage imbalance.

Percentage of Voltage Imbalance

$$= 100 \times \frac{\text{max voltage deviation from average voltage}}{\text{average voltage}}$$

EXAMPLE: Supply voltage is 460-3-60.

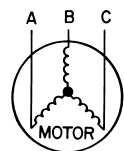

AB = 452 v
BC = 464 v
AC = 455 v

$$\begin{aligned} \text{Average Voltage} &= \frac{455 + 464 + 455}{3} \\ &= \frac{1371}{3} \\ &= 457 \end{aligned}$$

Determine maximum deviation from average voltage:

(AB) 457 - 452 = 5 v
(BC) 464 - 457 = 7 v
(AC) 457 - 455 = 2 v

Maximum deviation is 7 v.

Determine percent voltage imbalance:

$$\begin{aligned} \text{Percentage of Voltage Imbalance} &= 100 \times \frac{7}{457} \\ &= 1.53\% \end{aligned}$$

This amount of phase imbalance is satisfactory as it is below the maximum allowable 2%.

IMPORTANT: If the supply voltage phase imbalance is more than 2%, contact your local electric utility company immediately.

Unit failure as a result of operation on improper line voltage or excessive phase imbalance constitutes abuse and may cause damage to electrical components.

FIELD CONTROL WIRING — Install a Carrier-approved accessory thermostat assembly according to the installation instructions included with the accessory. Locate thermostat assembly on a solid wall in the conditioned space to sense average temperature.

Route thermostat cable or equivalent single leads of no. 18 AWG (American Wire Gage) colored wire from subbase terminals through conduit in unit to low-voltage connections as shown on unit label wiring diagram and in Fig. 12.

NOTE: For wire runs up to 50 ft, use no. 18 AWG insulated wire (35 C minimum). For 50 to 75 ft, use no. 16 AWG insulated wire (35 C minimum). For over 75 ft, use no. 14 AWG insulated wire (35 C minimum). All wire larger than no. 18 AWG cannot be directly connected to the thermostat and will require a junction box and splice at the thermostat.

Set heat anticipator settings as indicated in Table 3. Settings may be changed slightly to provide a greater degree of comfort for a particular installation.

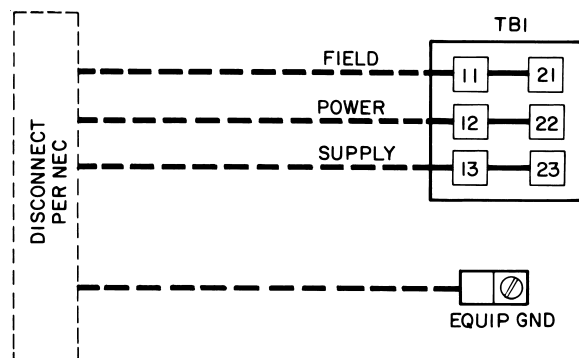

TB1 MAXIMUM WIRE SIZE

UNIT	VOLTAGE		
	208/230,380	460	575
50TJ			
All	350 kcmil	2/0	2/0

LEGEND

- EQUIP** — Equipment
- GND** — Ground
- kcmil** — Thousand Circular Mills
- NEC** — National Electrical Code
- TB** — Terminal Block

Fig. 11 — Field Power Wiring Connections

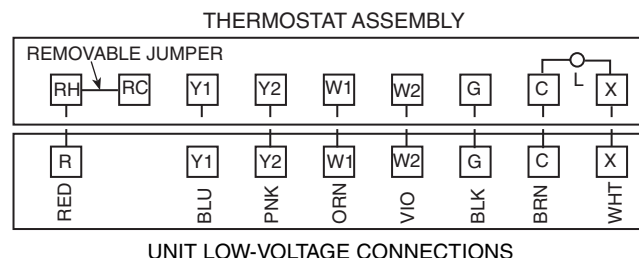

Fig. 12 — Field Control Thermostat Wiring

Table 2 — Electrical Data

UNIT 50TJ	NOMINAL VOLTAGE (3 Ph, 60 Hz)	VOLTAGE RANGE		COMPRESSOR				OFM			IFM		POWER EXHAUST		ELECTRIC HEAT*		POWER SUPPLY	
				No. 1		No. 2												
		Min	Max	RLA	LRA	RLA	LRA	Qty	Hp	FLA (ea)	Hp	FLA	FLA	LRA	kW	FLA	MCA	MOCP†
016 (15 Tons)	208/230	187	253	28.8	195	28.8	195	3	0.5	1.7	3.7	10.5/11.0	—	—	—	—	81/81	100/100
													4.6	18.8	—	—	85/86	110/110
													—	—	26/34	71/82	102/116	110/125
													4.6	18.8	26/34	71/82	108/122	110/125
	380	342	418	15.0	123	15.0	123	3	0.5	1.7	3.7	3.9	—	—	—	—	43	50
													2.3	6.0	—	—	45	60
													—	—	20	30	43	50
													2.3	6.0	20	30	46	60
	460	414	508	14.7	95	14.7	95	3	0.5	0.8	3.7	4.8	—	—	—	—	40	50
													2.3	6.0	—	—	43	50
													—	—	32	39	55	60
													2.3	6.0	32	39	58	60
575	518	633	10.8	80	10.8	80	3	0.5	0.75	3.0	3.9	—	—	—	—	30	40	
												2.1	4.8	—	—	32	40	
												—	—	50**	48	67	70	
												2.1	4.8	50**	48	70	70	
020 (18 Tons)	208/230	187	253	30.1	225	28.8	195	3	0.5	1.7	5.0	15.8/15.8	—	—	—	—	87/87	110/110
													4.6	18.8	—	—	92/92	110/110
													—	—	26/34	71/82	109/122	110/125
													4.6	18.8	26/34	71/82	114/128	125/150
	460	414	508	15.5	114	14.7	95	3	0.5	0.8	5.0	7.9	—	—	—	—	44	50
													2.3	6.0	—	—	47	60
													—	—	32	39	59	60
													2.3	6.0	32	39	61	70
	575	518	633	12.1	80	10.8	80	3	0.5	0.75	5.0	6.0	—	—	—	—	34	40
													2.1	4.8	—	—	36	40
													—	—	55	66	76	90
													2.3	6.0	55	66	79	90
024 (20 Tons)	208/230	187	253	37.8	239	30.1	225	2	1	6.6	7.5	25.0/25.0	—	—	—	—	116/116	150/150
													4.6	18.8	—	—	120/120	150/150
													—	—	26/34	71/82	120/134	150/150
													4.6	18.8	26/34	71/82	126/140	150/150
	380	342	418	21.2	145	16.7	140	2	1	3.9	7.5	15.0	—	—	—	—	66	80
													2.3	6.0	—	—	68	80
													—	—	20	30	66	80
													2.3	6.0	20	30	68	80
	460	414	508	17.2	125	15.5	114	2	1	3.3	7.5	13.0	—	—	—	—	57	70
													2.3	6.0	—	—	59	70
													—	—	32	39	65	70
													2.3	6.0	32	39	68	70
575	518	633	12.4	80	12.1	80	2	1	3.4	7.5	10.0	—	—	—	—	82	90	
												2.3	6.0	—	—	85	90	
												—	—	55	66	82	90	
												2.3	6.0	55	66	85	90	
575	518	633	12.4	80	12.1	80	2	1	3.4	7.5	10.0	—	—	—	—	112	125	
												2.3	6.0	—	—	115	125	
												—	—	80**	96	112	125	
												2.3	6.0	80**	96	115	125	
575	518	633	12.4	80	12.1	80	2	1	3.4	7.5	10.0	—	—	—	—	44	50	
												2.1	4.8	—	—	46	50	
												—	—	56/75**	156/180	187/211	200/225	
												4.6	18.8	56/75**	156/180	193/217	200/225	

Table 2 — Electrical Data (cont)

UNIT 50TJ	NOMINAL VOLTAGE (3 Ph, 60 Hz)	VOLTAGE RANGE		COMPRESSOR				OFM			IFM		POWER EXHAUST		ELECTRIC HEAT*		POWER SUPPLY	
		Min	Max	No. 1		No. 2		Qty	Hp	FLA (ea)	Hp	FLA	FLA	LRA	kW	FLA	MCA	MOCP†
				RLA	LRA	RLA	LRA											
028 (25 Tons)	208/230	187	253	41.0	350	37.8	239	2	1	6.6	10.0	28.0/28.0	—	—	—	—	130/130	150/150
													4.6	18.8	—	—	135/135	175/175
													—	—	26/34	71/82	130/138	150/150
													4.6	18.8	26/34	71/82	135/143	175/175
													—	—	42/56	117/135	181/170	200/175
													4.6	18.8	42/56	117/135	187/176	200/200
	380	342	418	21.8	151	21.2	145	2	1	3.9	10.0	17.0	—	—	—	—	73	90
													2.3	6.0	—	—	76	90
													—	—	20	30	73	90
													2.3	6.0	20	30	76	90
													—	—	35	52	87	90
													2.3	6.0	35	52	90	90
	460	414	508	21.8	158	17.2	125	2	1	2.8	10.0	14.6	—	—	—	—	66	80
													2.3	6.0	—	—	68	80
													—	—	32	39	67	80
													2.3	6.0	32	39	70	80
													—	—	55	66	84	90
													2.3	6.0	55	66	87	100
	575	518	633	17.3	125	12.4	80	2	1	3.4	10.0	13.0	—	—	—	—	54	70
													2.1	4.8	—	—	56	70
													—	—	80**	96	114	125
													2.3	6.0	80**	96	117	125
													—	—	—	—	—	—
													2.1	4.8	—	—	—	—

LEGEND

- FLA — Full Load Amps
- HACR — Heating, Air Conditioning and Refrigeration
- IFM — Indoor (Evaporator) Fan Motor
- LRA — Locked Rotor Amps
- MCA — Minimum Circuit Amps
- MOCP — Maximum Overcurrent Protection
- NEC — National Electrical Code
- OFM — Outdoor (Condenser) Fan Motor
- RLA — Rated Load Amps

*Heater capacity (kW) is based on heater voltage of 208 v, 240 v, 380 v, 480 v, and 575 v. Heaters are rated at 240 v, 380 v, 480 v, or 600 v. If power distribution voltage to unit varies from rated heater voltage, heater kW will vary accordingly.

†Fuse or HACR circuit breaker.
**Heaters are field installed only.

NOTES:

1. In compliance with NEC requirements for multimotor and combination load equipment (refer to NEC Articles 430 and 440), the overcurrent protective device for the unit shall be fuse or HACR breaker. Canadian units may be fuse or circuit breaker.
2. **Unbalanced 3-Phase Supply Voltage**
Never operate a motor where a phase imbalance in supply voltage is greater than 2%. Use the following formula to determine the percent of voltage imbalance.

$$\% \text{ Voltage Imbalance} = 100 \times \frac{\text{max voltage deviation from average voltage}}{\text{average voltage}}$$

Example: Supply voltage is 460-3-60.

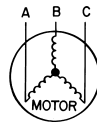

AB = 452 v
BC = 464 v
AC = 455 v

$$\begin{aligned} \text{Average Voltage} &= \frac{452 + 464 + 455}{3} \\ &= \frac{1371}{3} \\ &= 457 \end{aligned}$$

Determine maximum deviation from average voltage.

- (AB) 457 - 452 = 5 v
- (BC) 464 - 457 = 7 v
- (AC) 457 - 455 = 2 v

Maximum deviation is 7 v.

Determine percent of voltage imbalance.

$$\begin{aligned} \% \text{ Voltage Imbalance} &= 100 \times \frac{7}{457} \\ &= 1.53\% \end{aligned}$$

This amount of phase imbalance is satisfactory as it is below the maximum allowable 2%.

IMPORTANT: If the supply voltage phase imbalance is more than 2%, contact your local electric utility company immediately.

3. MCA calculation for units with electric heaters over 50 kW = (1.25 x IFM amps) + (1.00 x heater FLA).



OPTIONAL NON-FUSED DISCONNECT — On units with the optional non-fused disconnect, incoming power will be wired into the disconnect switch. Refer to Fig. 13 for wiring for 100 and 200 amp disconnect switches. Units with an MOCP under 100 will use the 100 amp disconnect switch. Units with an MOCP over 100 will use the 200 amp disconnect switch. Refer to the applicable disconnect wiring diagram.

To prevent breakage during shipping, the disconnect handle and shaft are shipped and packaged inside the unit control box. Install the disconnect handle before unit operation. To install the handle and shaft, perform the following procedure:

1. Open the control box door and remove the handle and shaft from shipping location.
2. Loosen the Allen bolt located on the disconnect switch. The bolt is located on the square hole and is used to hold the shaft in place. The shaft cannot be inserted until the Allen bolt is moved.
3. Insert the disconnect shaft into the square hole on the disconnect switch. The end of the shaft is specially cut and the shaft can only be inserted in the correct orientation.
4. Tighten the Allen bolt to lock the shaft into position.
5. Close the control box door.
6. Attach the handle to the external access door with the two screws provided. When the handle is in the ON position, the handle will be vertical. When the handle is in the OFF position, the handle will be horizontal.
7. Turn the handle to the OFF position and close the door. The handle should fit over the end of the shaft when the door is closed.
8. The handle must be in the OFF position to open the control box door.

OPTIONAL CONVENIENCE OUTLET — On units with optional convenience outlet, a 115-v GFI (ground fault interrupt) convenience outlet receptacle is provided for field wiring. Field wiring should be run through the $\frac{7}{8}$ -in. knockout provided in the basepan near the return air opening.

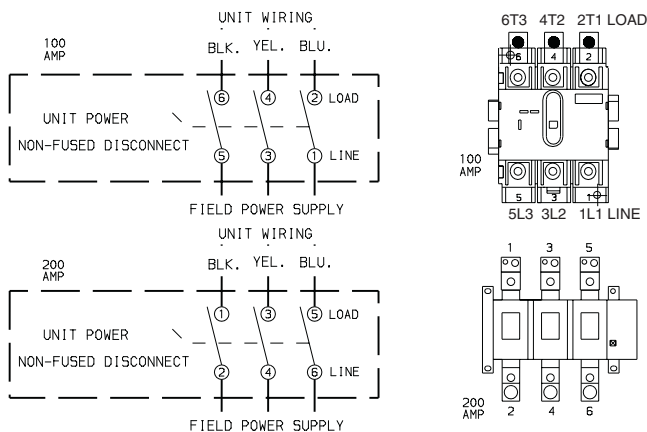

NOTE: The disconnect takes the place of TB-1 as shown on the unit wiring diagram label and the component arrangement label.

Fig. 13 — Optional Non-Fused Disconnect Wiring

Step 7 — Make Outdoor-Air Inlet Adjustments

MANUAL OUTDOOR-AIR DAMPER — All units (except those equipped with a factory-installed economizer) have a manual outdoor-air damper to provide ventilation air. Damper can be preset to admit up to 25% outdoor air into return-air compartment. To adjust, loosen securing screws and move damper to desired setting. Then retighten screws to secure damper (Fig. 14).

OPTIONAL ECONOMISER

EconoMi\$er Motor Control Module (Fig. 15-17) — Set the ECONSP dial to the “D” setting (Fig. 16). The control module is located on the EconoMi\$er motor. See Fig. 15 and 17.

Damper Vent Position Setting

1. Set fan switch at ON position (continuous fan operation) and close night switch if used.
2. Set system selector switch to OFF position.
3. Turn Min Pos (%) dial slowly until dampers assume desired vent position. *Do not manually operate EconoMi\$er motor since damage to motor will result.*

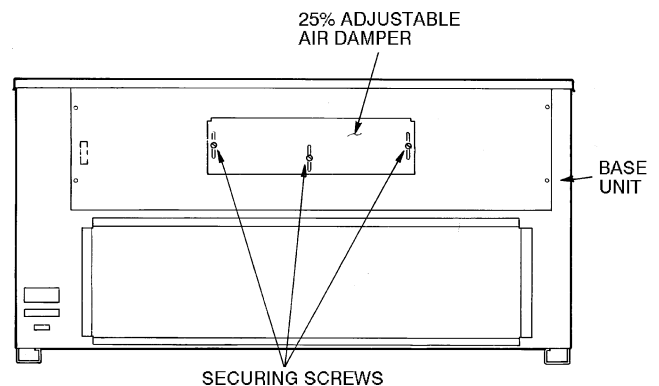

Fig. 14 — 25% Outdoor-Air Section Details

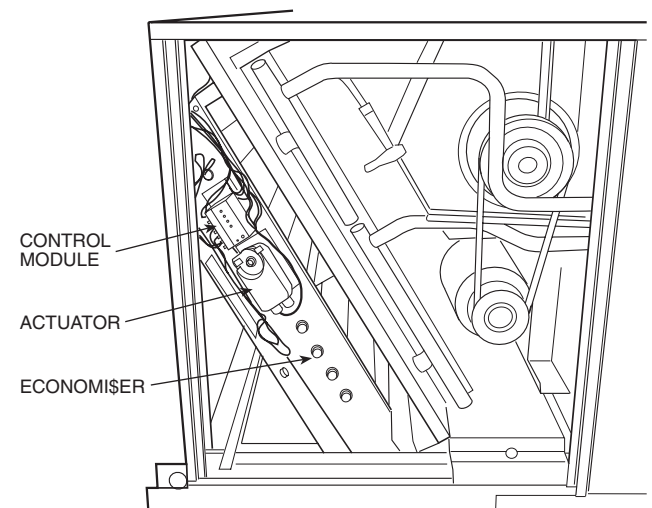

Fig. 15 — EconoMi\$er Damper Assembly — End View

Table 3 — Heat Anticipator Settings

UNIT 50TJ	UNIT VOLTAGES	kW*	STAGE 1	STAGE 2
016-028	208/230-3-60	26/34	.40	.66
		42/56	.66	.40
		56/75	.66	.66
	380-3-60	20	.40	.40
		35	.40	.66
	460-3-60	32	.40	.40
		55	.40	.66
	575-3-60	80	.66	.66
		50	.66	.66

*Heater kW is based on heater voltage of 208 v, 240 v, 380 v, 480 v, and 575 v.

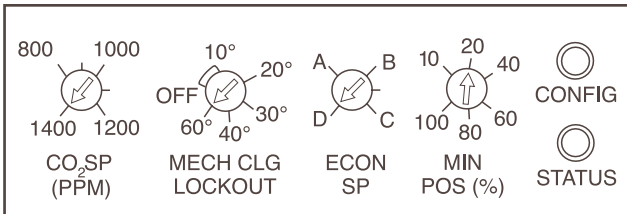

Fig. 16 — EconoMi\$er Control Module Adjustment Potentiometers

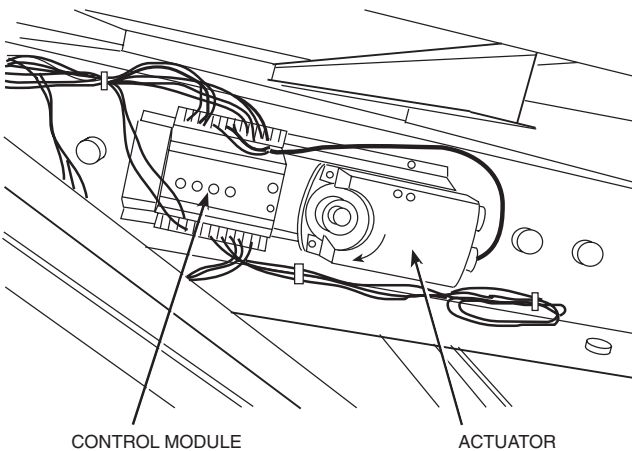

Fig. 17 — EconoMi\$er Control Module Location

Step 8 — Install Outdoor-Air Hood — The same type of factory-installed hood is used on units with 25% air ventilation and units with an EconoMi\$er.

NOTE: The hood top panel, upper and lower filter retainers, hood drain pan, baffle (028), and filter support bracket are secured opposite the condenser end of the unit. The screens, hood side panels, remaining section of filter support bracket, seal strip, and all other hardware are in a package located inside the return-air filter access panel (Fig. 18).

1. Attach seal strip to upper filter retainer. See Fig. 19.
2. Assemble hood top panel and side panels, upper filter retainer, and hood drain pan (Fig. 20).
3. Secure lower filter retainer and long section of filter support bracket to unit. See Fig. 20. Leave screws loose on 028 units.
4. Slide baffle (size 028 unit) behind lower filter retainer and tighten screws.

5. Loosen sheet metal screws for base unit top panel located above outdoor-air inlet opening, and remove screws for hood side panels located on the sides of the outdoor-air inlet opening.
6. Match notches in hood top panel to unit top panel screws. Insert hood flange between unit top panel flange and unit. Tighten screws.
7. Hold hood side panel flanges flat against unit, and install screws removed in Step 5.
8. Insert outdoor-air inlet screens and spacer in channel created by lower filter retainer and filter support bracket.
9. Attach remaining short section of filter support bracket.

OUTDOOR AIR ENTHALPY SENSOR INSTALLATION — Perform the following procedure to install the outdoor air enthalpy sensor (part no. CROUTENT001A00).

1. Remove the outdoor air temperature sensor cover. See Fig. 21. Save cover and screws.
2. Disconnect the wiring from the installed outdoor air temperature sensor. See Fig. 22.
3. Use a 1/4-in. nut driver to remove the 2 screws securing the outdoor air temperature sensor to the sheet metal.
4. Mount the outdoor air enthalpy sensor in the outdoor air temperature sensor location using the screws removed in Step 3.
5. Connect the outdoor air enthalpy sensor wiring harness to the EconoMi\$er control module and sensor.
6. Re-install sensor cover saved from Step 1.

RETURN AIR TEMPERATURE SENSOR OR RETURN AIR ENTHALPY SENSOR INSTALLATION — Perform the following procedure to install the return air temperature sensor (part no. CRRETTMP001A00) or return air enthalpy sensor (part no. CRRETTENT001A00).

1. Attach the sensor to the mounting bracket using 2 self-tapping 1/2-in. screws provided.
2. Mount the bracket to the inside of the return air opening flange using a 1/4-in. nut driver and 2 no. 6 sheet metal screws.

NOTE: The sensor must be mounted in an upright position.

3. Feed the sensor wiring through the bushing in EconoMi\$er to secure wires.
4. Route sensor wiring harness from sensor to EconoMi\$er control module. Secure wiring harness to the original harness using tie wraps.
5. Wire the sensor to the EconoMi\$er control module. See Fig. 23 and 24.

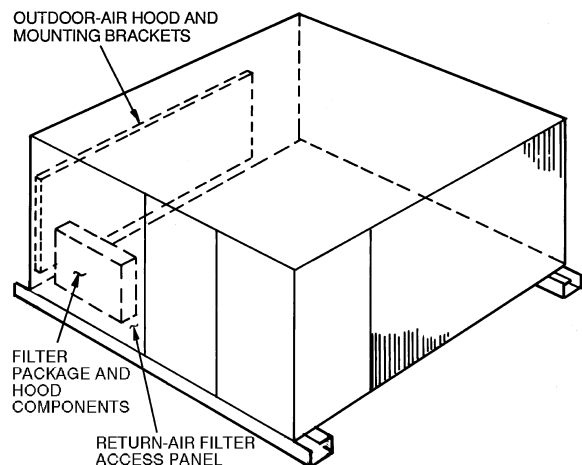
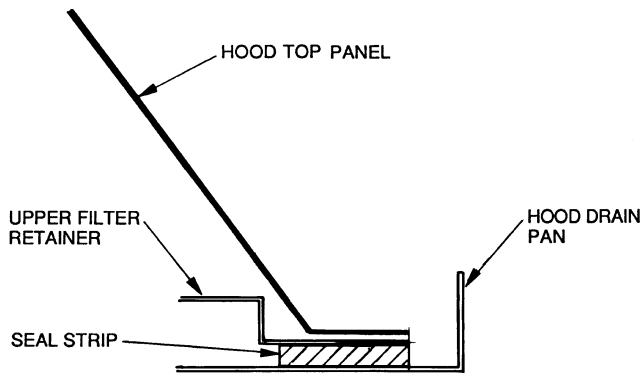
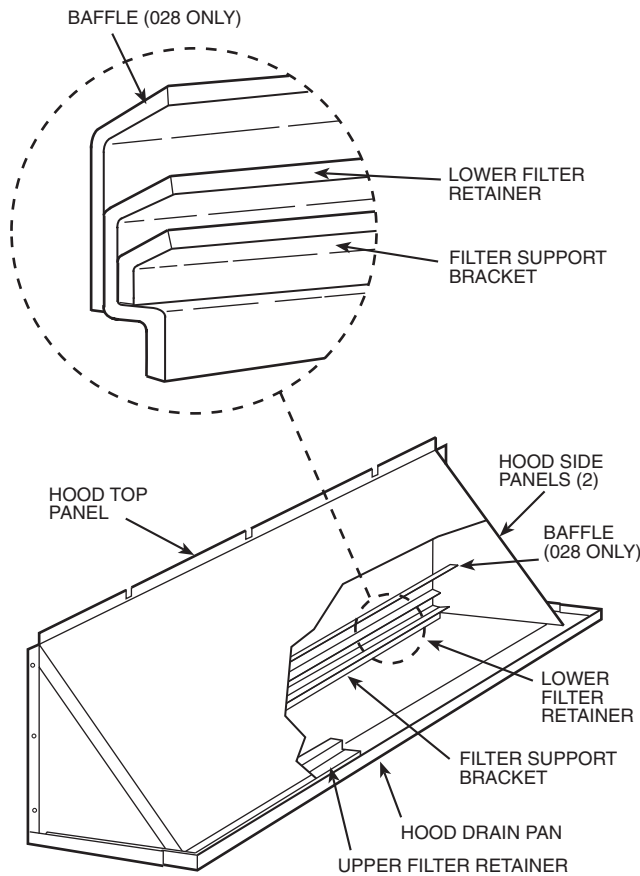

Fig. 18 — Outdoor-Air Hood Component Location



**Fig. 19 — Seal Strip Location
(Air Hood Cross-Sectional View)**



NOTE: The outdoor-air hood comes with a baffle which is used on 028 units only; discard baffle for 016-024 units.

Fig. 20 — Outdoor-Air Hood Details

COMMISSIONING — The EconoMi\$er saves energy when it uses outdoor air to provide free cooling instead of mechanical air conditioning. The EconoMi\$er switchover strategy determines if the outdoor air is suitable for free cooling. The EconoMi\$er chooses the switchover strategy with the most energy savings, provided that the required sensors are connected and functioning normally.

IMPORTANT: If a sensor stops functioning normally (becomes unreliable), the EconoMi\$er switches to the next best strategy.

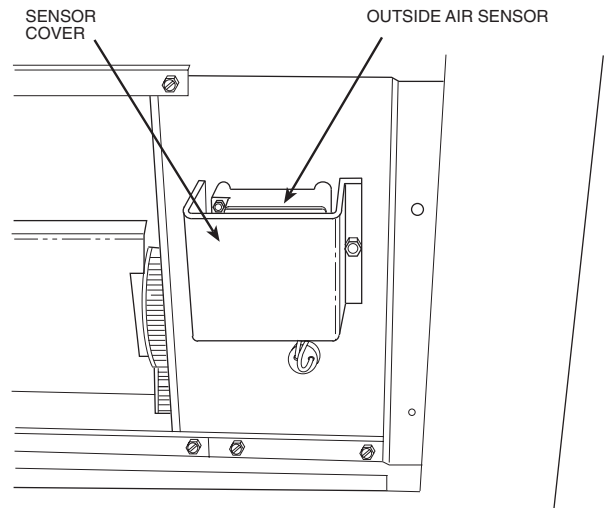

Fig. 21 — Outdoor-Air Sensor Location

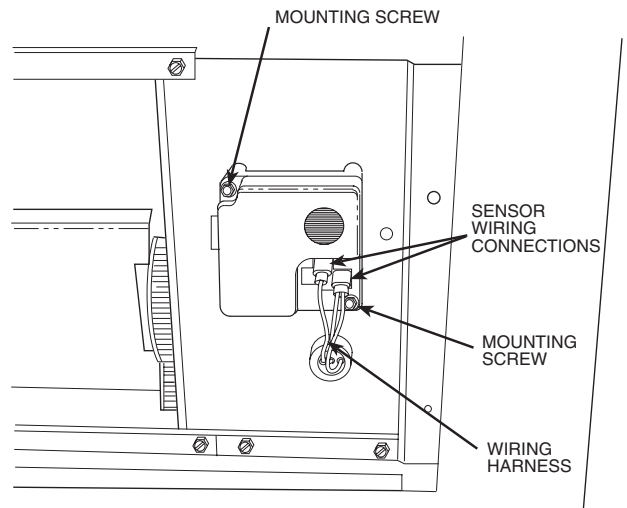

Fig. 22 — Outdoor-Air Sensor Details

Refer to Table 4 to determine the sensors required for each strategy.

Differential Enthalpy Switchover Strategy — The differential enthalpy switchover strategy must be selected manually, if required. To enable, press and hold the CONFIG button for 30 seconds, then release. The LED will flash twice to indicate the change of configuration.

To return to single enthalpy mode, press and hold the CONFIG button for 30 seconds. The LED will flash once to indicate the change of configuration.

DISCHARGE AIR THERMISTOR (DAT) — The discharge air thermistor is factory-mounted on the supply-fan housing in the fan section of the unit. The DAT is factory-wired to the EconoMi\$er Control Module.

CO₂ CONTROL SETUP — If a CO₂ sensor is not being used, proceed to the next section. If a CO₂ sensor is being used, perform the following:

1. Determine the value at which you want the minimum position of the dampers to begin opening to allow a greater amount of outdoor air to enter. The range is 800 to 1,400 ppm.
2. Locate the CO₂ SP (PPM) potentiometer and adjust to the desired set point. See Fig. 16.

MECHANICAL COOLING LOCKOUT — Determine the outdoor-air temperature at which you want the mechanical cooling (compressors) to be disabled. Locate the mechanical cooling lockout (MECH CLG LOCKOUT) potentiometer. To disable this feature, turn the potentiometer counterclockwise (CCW) to the OFF position. Otherwise, set the value between 10 and 60 F. Mechanical cooling will not operate when the outdoor air temperature is below this value. See Fig. 16.

DRY BULB CHANGEOVER SET UP — Determine the dry bulb changeover set point from Table 5. The settings are A, B, C and D. Locate the ECON SP potentiometer and set the dry bulb changeover set point. See Fig. 16. When the OAT is above this set point, the damper is limited to minimum position setting.

If a potentiometer fails, its setting will default to the values in Table 6.

Table 4 — EconoMi\$er Switchover Control Strategy

ECONOMISER SWITCHOVER STRATEGY	SENSORS REQUIRED			
	Outdoor Air Temperature	Outdoor Air Enthalpy	Return Air Temperature	Return Air Enthalpy
Dry Bulb	X			
Single Enthalpy		X		
Differential Temperature	X		X	
Differential Enthalpy*		X		X

*Must be selected manually.

Table 5 — Changeover Set Points

SETTINGS	A	B	C	D
Dry Bulb (°F)	73	69	66	63
Single Enthalpy* (Btu/lb)	27	25	24	22
Differential Temperature* (°F, Not Adjustable)	2	2	2	2
Differential Enthalpy* (Btu/lb, Not Adjustable)	1	1	1	1

*Field-installed accessory.

Table 6 — Default Potentiometer Settings

POTENTIOMETER	DEFAULT SETTING
CO ₂ SP (PPM)	1,000
MECH CLG LOCKOUT	50 F
ECON SP	D
MIN POS (%)	20

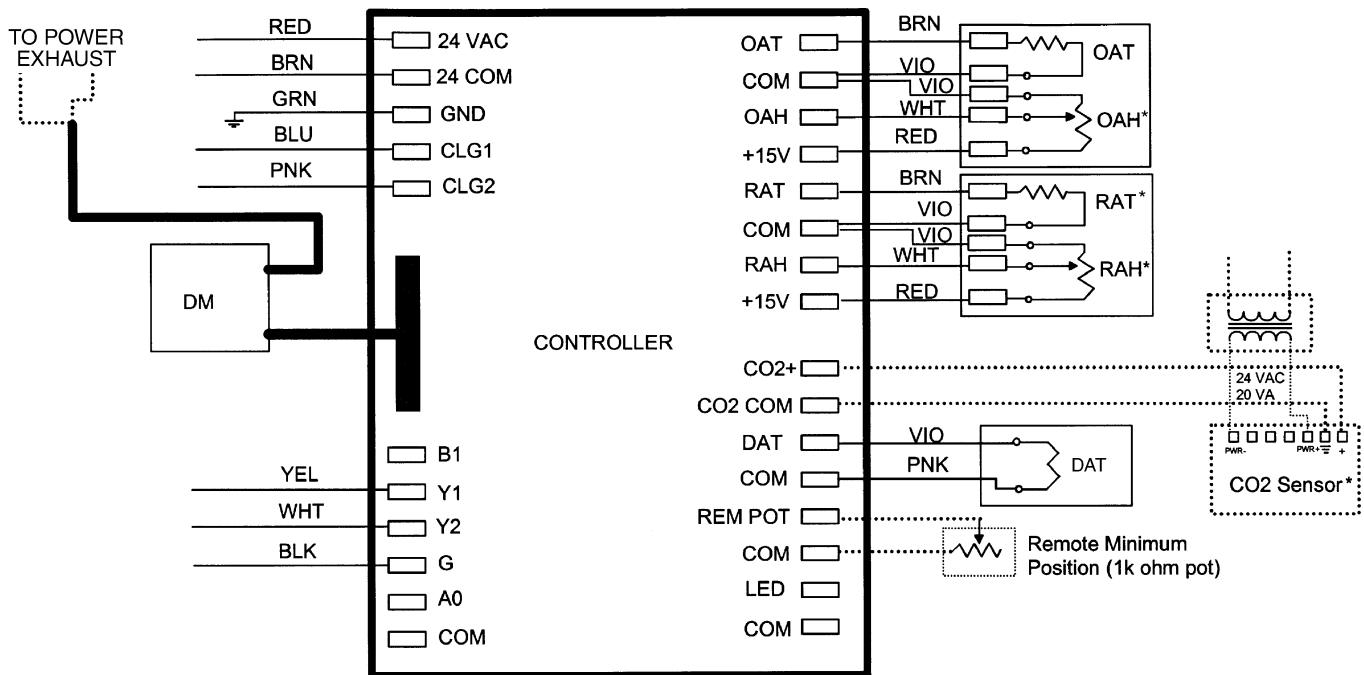

LEGEND

- COM — Common
- DAT — Discharge Air Thermistor
- DM — Damper Motor
- GND — Ground
- OAH — Outdoor-Air Enthalpy Sensor
- OAT — Outdoor-Air Temperature Sensor
- POT — Potentiometer
- RAH — Return-Air Enthalpy Sensor
- RAT — Return-Air Temperature Sensor
- REM — Remote

*OAT sensor shipped with economizer option. OAH, RAT, RAH and CO₂ are field-installed accessories.

Fig. 23 — Typical EconoMi\$er Sensor Wiring

VENTILATION AIR (Minimum Position Set Up) — If ventilation air is not required, skip this section. If ventilation air is required, perform the following:

1. The indoor fan must be on to set the ventilation air. Either put the thermostat in the continuous fan mode or jumper the R and G terminals at the rooftop unit connection board.
2. Locate the minimum position (MIN POS) potentiometer. Turn the potentiometer full CCW to fully close the outdoor air dampers. Turn the potentiometer gradually clockwise (CW) to the desired position. See Fig. 16.
3. Replace the filter access panel. See Fig. 18. Ensure the filter access panel is securely engaged.
4. Calculate the minimum airflow across the EconoMi\$er.
 - a. Calculate % of outside air using the following formula.

$$\% \text{ Outdoor air through EconoMi\$er} = \frac{\text{Mixture Temp} - \text{Return Air Temp}}{\text{Outdoor Temp} - \text{Return Air Temp}}$$
 - b. Multiply total CFM by percentage outdoor air, this gives outdoor air volume in CFM.

⚠ WARNING

Personal Injury Hazard. Avoid possible injury by keeping fingers away from damper blades.

Step 9 — Install All Accessories — After all the factory-installed options have been adjusted, install all field-installed accessories. Refer to the accessory installation instructions included with each accessory.

MOTORMASTER® I CONTROL INSTALLATION (50TJ016 and 020 Only)

Install Field-Fabricated Wind Baffles — Wind baffles must be field-fabricated for all units to ensure proper cooling cycle operation at low ambient temperatures. See Fig. 25 for baffle details. Use 20-gage, galvanized sheet metal, or similar corrosion-resistant metal for baffles. Use field-supplied screws to attach baffles to unit. Screws should be 1/4-in. diameter and 5/8-in. long. Drill required screw holes for mounting baffles.

⚠ CAUTION

To avoid damage to the refrigerant coils and electrical components, use recommended screw sizes only. Use care when drilling holes.

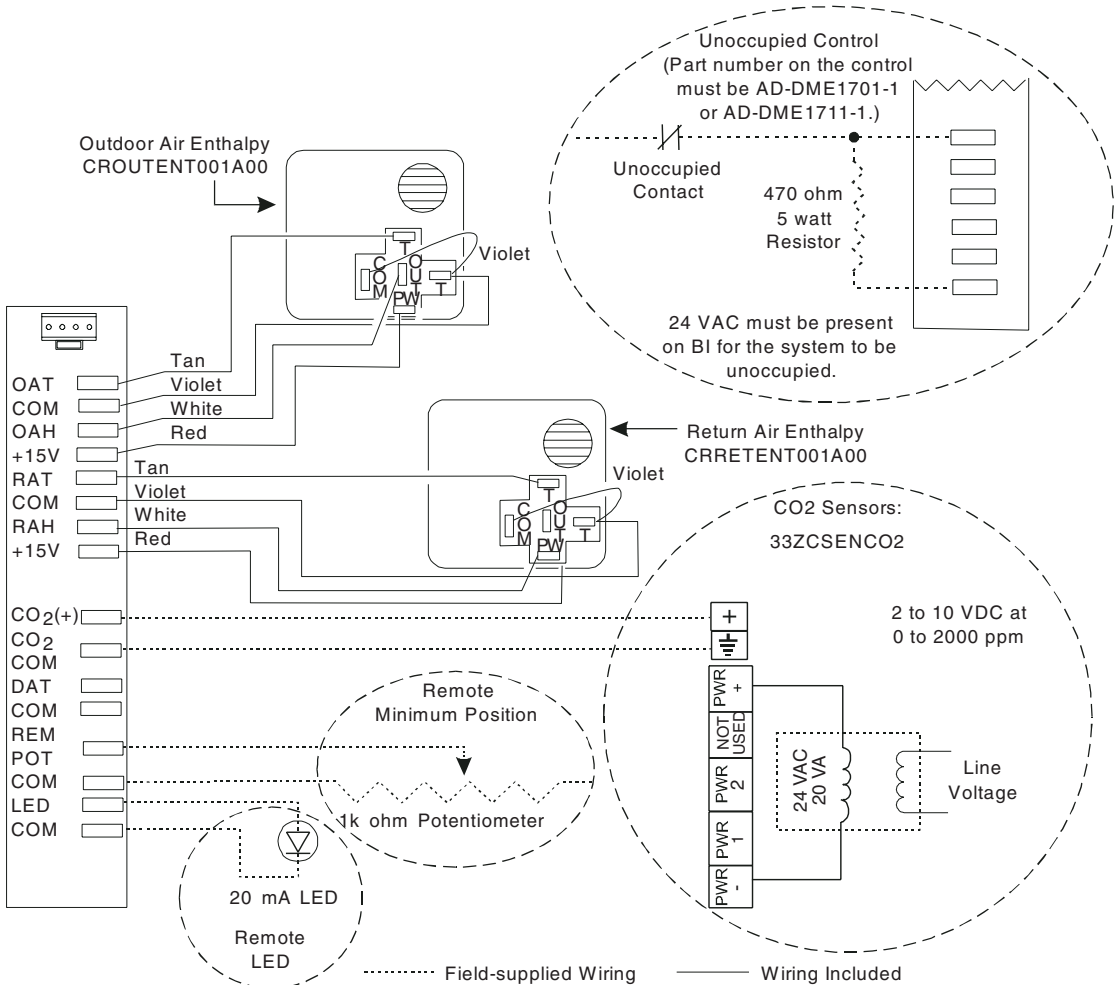

Fig. 24 — Typical EconoMi\$er Sensor Wiring

Install Motormaster I Controls — Only one Motormaster I control is required per unit. The Motormaster I control must be used in conjunction with the Accessory 0° F Low Ambient Kit (purchased separately). The Motormaster I device controls outdoor fan no. 1 while outdoor fans no. 2 and 3 are sequenced off by the Accessory 0° F Low Ambient Kit.

Accessory 0° F Low Ambient Kit — Install the Accessory 0° F Low Ambient Kit per instruction supplied with accessory.

Sensor Assembly — Install the sensor assembly in the location shown in Fig. 26.

Motor Mount — To ensure proper fan height, replace the existing motor mount with the new motor mount provided with accessory.

Transformer (460 and 575-v Units Only) — On 460 and 575-volt units a transformer is required. The transformer is provided with the accessory and must be field-installed.

Motormaster I Control — Recommended mounting location is on the inside of the panel to the left of the control box. The control should be mounted on the inside of the panel, vertically, with leads protruding from bottom of extrusion.

MOTORMASTER® III CONTROL INSTALLATION (50TJ024 and 028 Only)

Install Field-Fabricated Wind Baffles — Wind baffles must be field-fabricated for all units to ensure proper cooling cycle operation at low ambient temperatures. See Fig. 25 for baffle details. Use 20-gage, galvanized sheet metal, or similar corrosion-resistant metal for baffles. Use field-supplied screws to attach baffles to unit. Screws should be 1/4-in. diameter and 5/8-in. long. Drill required screw holes for mounting baffles.

⚠ CAUTION

To avoid damage to the refrigerant coils and electrical components, use recommended screw sizes only. Use care when drilling holes.

Replace Outdoor Motor — Replace outdoor fan motor no. 1 with motor included in accessory kit. Existing motor is not Motormaster® III compatible.

Install Motormaster III Controls — Only one Motormaster III control is required per unit.

Sensor — Install the sensor for thermistor input control in the location shown in Fig. 27. Connect sensor leads to the purple and grey control signal leads on the Motormaster III control.

Signal Selection Switch — Remove the cover of the Motormaster III control. Set the switch to accept the thermistor sensor input signal. Set the frequency to match the unit power supply (60 Hz).

Motormaster III Control — Recommended mounting location is beneath the control box, mounted to the partition that separates the control box section from the indoor section.

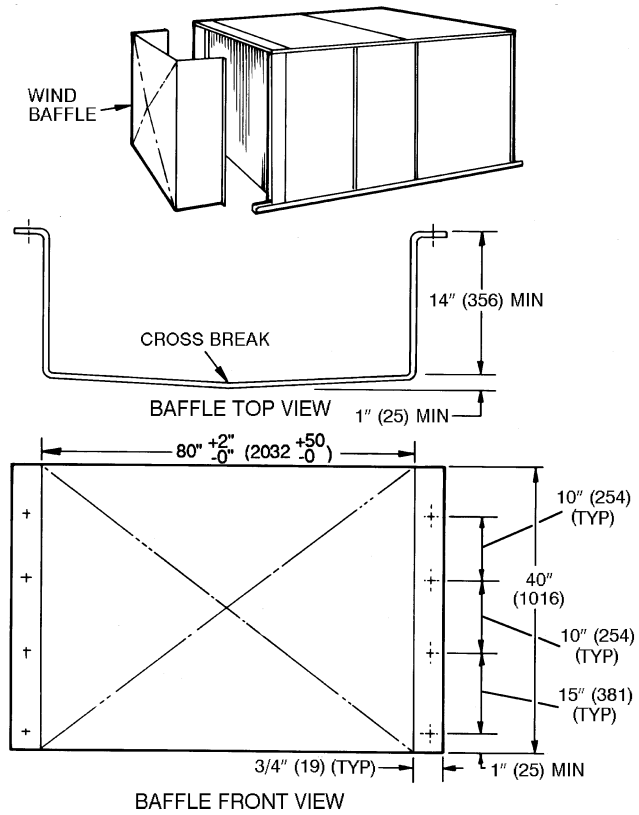

NOTE: Dimensions in () are in mm.

Fig. 25 — Wind Baffle Details

NOTE: If unit power is supplied through the roof curb and basepan of the unit, mount the Motormaster III control on the corner post adjacent to the conduit running from the basepan to the bottom of the control box.

Step 10 — Install Humidistat for Optional MoistureMiser Dehumidification Package —

MositureMiser dehumidification package operation can be controlled by field installation of a Carrier-approved humidistat. To install the humidistat perform the following procedure:

1. Locate humidistat on a solid interior wall in the conditioned space. Location should be a well ventilated area to sense average humidity.
2. Route thermostat cable or equivalent single leads of colored wire from Humidistat terminals through conduit in unit to the low voltage connection on the 2-pole terminal strip (TB3) as shown in Fig. 28 and Fig. 29.

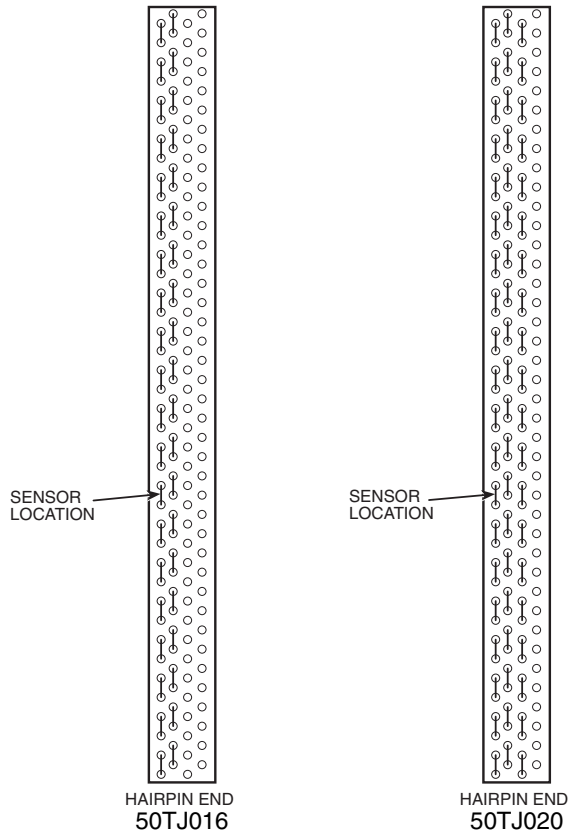

NOTE: All sensors are located on the eighth hairpin up from the bottom.

Fig. 26 — Motormaster® I Sensor Locations

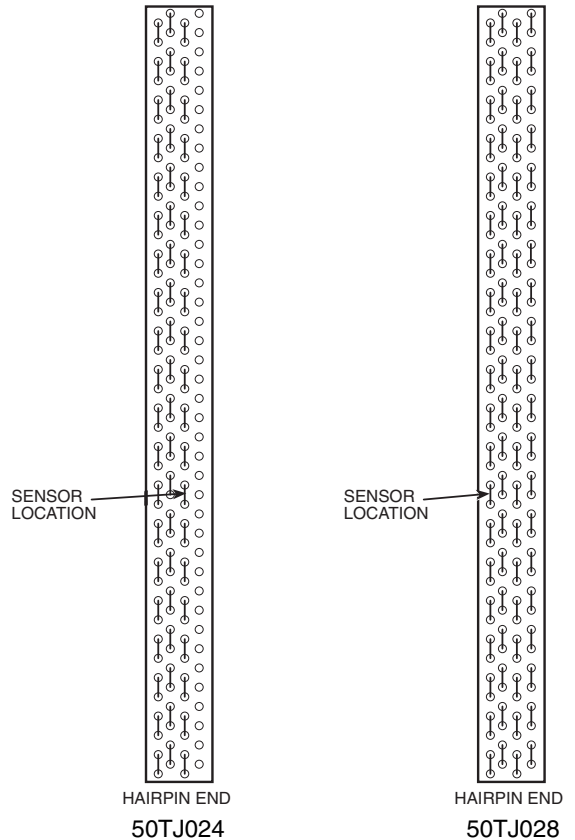

NOTE: All sensors are located on the eighth hairpin up from the bottom.

Fig. 27 — Motormaster III Sensor Locations

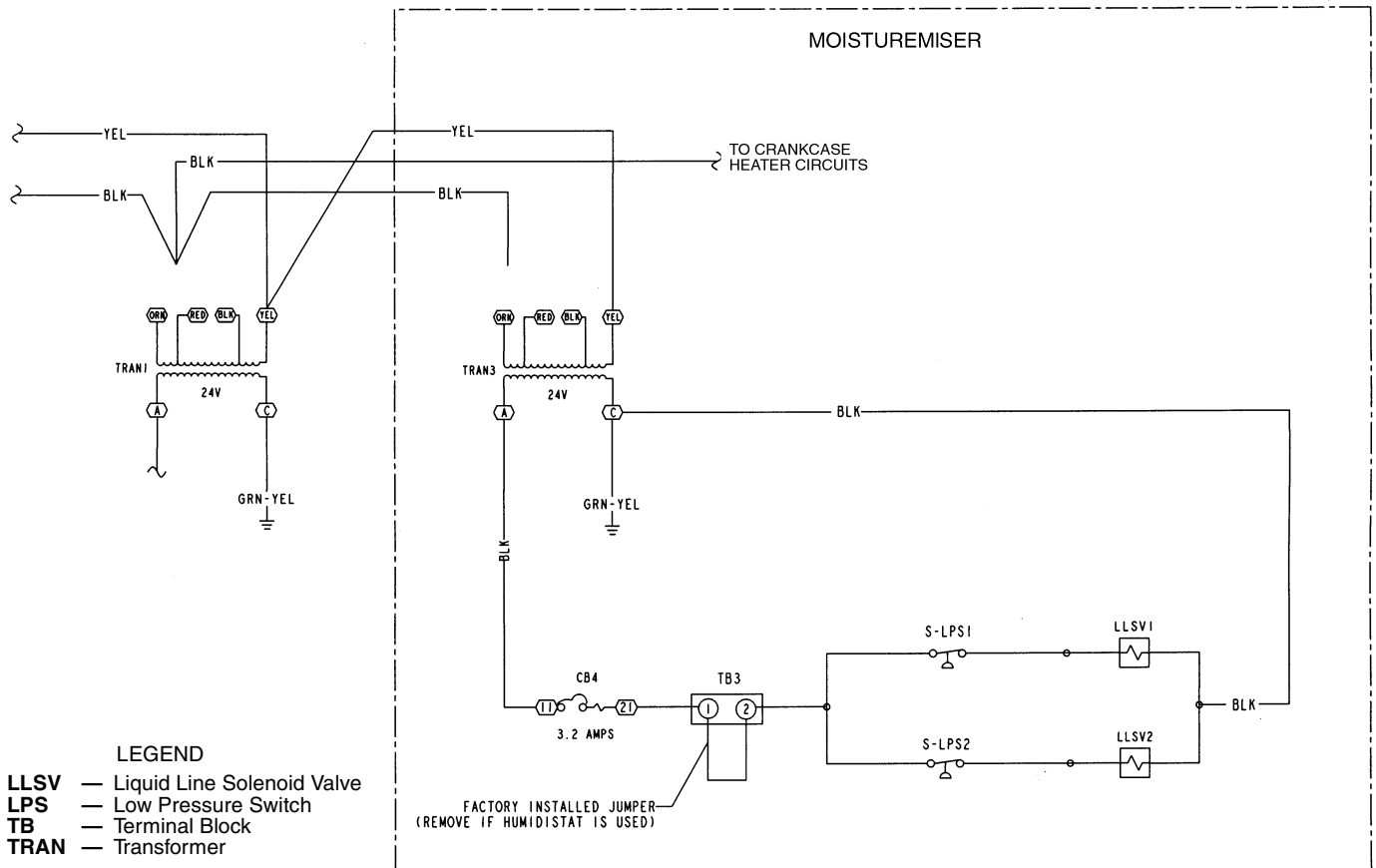

Fig. 28 — Typical MoistureMiser Dehumidification Package Humidistat Wiring Schematic (460V Unit Shown)

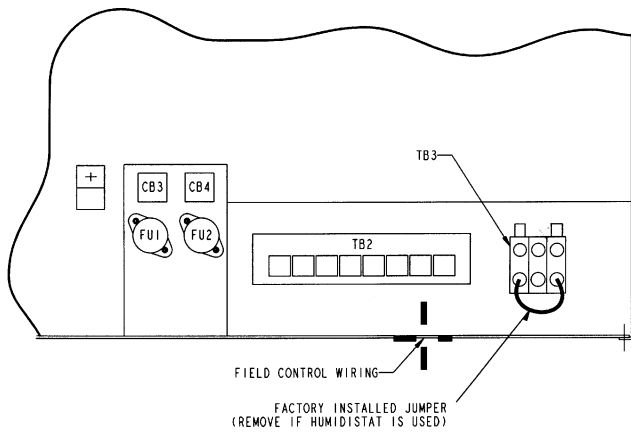

Fig. 29 — Typical MoistureMiser Dehumidification Package Control Box

START-UP

Use the following information and Start-Up Checklist on page CL-1 to check out unit PRIOR to start-up.

Unit Preparation — Check that unit has been installed in accordance with these installation instructions and all applicable codes.

Internal Wiring — Check all electrical connections in unit control boxes; tighten as required.

Crankcase Heater (Size 028 and Units with MoistureMiser Dehumidification Package Only) — Heater is energized as long as there is power to unit and compressor is not operating.

IMPORTANT: Unit power must be on for 24 hours prior to start-up. Otherwise, damage to compressor may result.

Compressor Mounting — Compressors are internally spring mounted. Do not loosen or remove compressor hold-down bolts.

Refrigerant Service Ports — Each refrigerant system has a total of 3 Schrader-type service gage ports. One port is located on the suction line, one on the compressor discharge line, and one on the liquid line. In addition Schrader-type valves are located underneath the low-pressure switches. Be sure that caps on the ports are tight.

Compressor Rotation — It is important to be certain the compressors are rotating in the proper direction. To determine whether or not compressors are rotating in the proper direction:

1. Connect service gages to suction and discharge pressure fittings.
2. Energize the compressor.
3. The suction pressure should drop and the discharge pressure should rise, as is normal on any start-up.

If the suction pressure does not drop and the discharge pressure does not rise to normal levels:

1. Note that the evaporator fan is probably also rotating in the wrong direction.
2. Turn off power to the unit.
3. Reverse any two of the incoming power leads.
4. Turn on power to the compressor.

The suction and discharge pressure levels should now move to their normal start-up levels.

NOTE: When compressors are rotating in the wrong direction, the unit will have increased noise levels and will not provide heating and cooling.

After a few minutes of reverse operation, the scroll compressor internal overload protection will open, which will activate the unit's lockout and requires a manual reset. Reset is accomplished by turning the thermostat on and off.

Evaporator Fan — Fan belt and variable pulleys are factory installed. Remove tape from the fan pulley. See Table 7 for Air Quantity Limits. See Tables 8-10 for Fan Performance data. Be sure that fans rotate in the proper direction. See Tables 11-13 for Static Pressure information for accessories and options. See Table 14 for fan rpm at various fan motor pulley settings. To alter fan performance, see Evaporator-Fan Performance Adjustment section, page 25.

Table 7 — Air Quantity Limits

UNIT 50TJ	MINIMUM CFM	MAXIMUM CFM
016	4500	7,500
020	5400	9,000
024	6000	10,000
028	7000	11,250

Condenser Fans and Motors — Fans and motors are factory set. Refer to Condenser-Fan Adjustment section (page 26) as required.

Return-Air Filters — Check that correct filters are installed in filter tracks. See Table 1. Do not operate unit without return-air filters.

Outdoor-Air Inlet Screens — Outdoor-air inlet screens must be in place before operating unit.

Accessory EconoMi\$er Adjustment — Remove filter access panel. Check that outdoor-air damper blades are closed and return-air damper blades are open.

EconoMi\$er operation and adjustment is described in Base Unit Operation and EconoMi\$er Adjustment sections (pages 23 and 27), respectively.

Table 8 — Fan Performance — 50TJ016

50TJ016 (15 TONS)*																		
Airflow (Cfm)	Available External Static Pressure (in. wg)																	
	0.2			0.4			0.6			0.8			1.0			1.2		
	Rpm	Bhp	Watts	Rpm	Bhp	Watts	Rpm	Bhp	Watts	Rpm	Bhp	Watts	Rpm	Bhp	Watts	Rpm	Bhp	Watts
4500	684	1.28	1102	791	1.49	1283	887	1.70	1466	977	1.92	1652	1061	2.13	1841	1139	2.36	2034
4800	715	1.47	1265	817	1.68	1451	910	1.90	1638	997	2.12	1828	1078	2.34	2021	1155	2.57	2217
5100	747	1.67	1442	844	1.89	1633	934	2.12	1825	1018	2.34	2019	1097	2.57	2216	1171	2.80	2416
5400	779	1.90	1635	872	2.12	1831	959	2.35	2027	1040	2.58	2226	1117	2.81	2426	1189	3.05	2629
5700	812	2.14	1844	901	2.37	2044	985	2.60	2245	1063	2.84	2448	1138	3.07	2652	1209	3.31	2858
6000	845	2.40	2068	931	2.64	2273	1011	2.87	2478	1087	3.11	2685	1160	3.35	2893	1229	3.60	3103
6300	878	2.68	2309	961	2.92	2518	1039	3.16	2728	1112	3.41	2939	1183	3.65	3151	1250	3.90	3365
6600	912	2.98	2566	992	3.22	2780	1067	3.47	2994	1138	3.72	3209	1207	3.97	3425	1273	4.22	3642
6900	946	3.29	2841	1023	3.55	3059	1096	3.80	3277	1165	4.05	3496	1232	4.31	3716	—	—	—
7200	981	3.63	3133	1055	3.89	3355	1125	4.15	3578	—	—	—	—	—	—	—	—	—
7500	1016	3.99	3443	1087	4.25	3669	—	—	—	—	—	—	—	—	—	—	—	—

50TJ016 (15 TONS)* (cont)																
Airflow (Cfm)	Available External Static Pressure (in. wg)															
	1.4			1.6			1.8			1.9			2.0			
	Rpm	Bhp	Watts	Rpm	Bhp	Watts	Rpm	Bhp	Watts	Rpm	Bhp	Watts	Rpm	Bhp	Watts	
4500	1214	2.59	2230	1285	2.82	2430	1353	3.05	2633	1386	3.17	2736	1418	3.29	2839	
4800	1228	2.80	2417	1297	3.04	2619	1364	3.27	2825	1396	3.40	2928	1428	3.52	3033	
5100	1243	3.04	2618	1311	3.27	2823	1376	3.51	3031	1408	3.64	3136	1439	3.76	3242	
5400	1259	3.29	2835	1326	3.53	3043	1390	3.77	3254	1421	3.90	3360	1452	4.02	3467	
5700	1277	3.56	3067	1342	3.80	3278	1405	4.05	3492	1435	4.17	3600	1466	4.30	3708	
6000	1295	3.84	3316	1359	4.09	3530	1421	4.34	3746	—	—	—	—	—	—	
6300	1315	4.15	3580	—	—	—	—	—	—	—	—	—	—	—	—	
6600	—	—	—	—	—	—	—	—	—	—	—	—	—	—	—	
6900	—	—	—	—	—	—	—	—	—	—	—	—	—	—	—	
7200	—	—	—	—	—	—	—	—	—	—	—	—	—	—	—	
7500	—	—	—	—	—	—	—	—	—	—	—	—	—	—	—	

LEGEND

- Bhp** — Brake Horsepower
- FIOP** — Factory-Installed Option
- Watts** — Input Watts to Motor

*Standard low-medium static drive range is 891 to 1179 rpm (for 208/230, 380 and 460 v units) or 1159 to 1429 rpm (for 575-v units). Alternate high-static drive range is 1227 to 1550 (for 208/230, 380, and 460 v units). The alternate high-static drive is not available for 50TJ016 575-v units. Other rpms require a field-supplied drive.

NOTES:

1. Maximum continuous bhp is 4.25 (208/230, 380 and 460 v) or 3.45 (575 v) and the maximum continuous watts are 3775 (208/230, 380, and 460 v) or 3065 (575 v). Do not adjust motor rpm such that motor maximum bhp and/or watts is exceeded at the maximum operating cfm.

2. Static pressure losses (i.e., EconoMiSer) must be added to external static pressure before entering Fan Performance table.
3. Interpolation is permissible. Do not extrapolate.
4. Fan performance is based on wet coils, clean filters, and casing losses. See Table 11 for accessory/FIOP static pressure information.
5. Extensive motor and drive testing on these units ensures that the full horsepower and watts range of the motor can be utilized with confidence. Using your fan motors up to the watts or bhp rating shown will not result in nuisance tripping or premature motor failure. Unit warranty will not be affected.
6. Use of a field-supplied motor may affect wiring size. Contact your Carrier representative for details.

Table 9 — Fan Performance — 50TJ020 and 024

50TJ020, 024 (18 and 20 TONS)*

Airflow (Cfm)	Available External Static Pressure (in. wg)																	
	0.2			0.4			0.6			0.8			1.0			1.2		
	Rpm	Bhp	Watts	Rpm	Bhp	Watts	Rpm	Bhp	Watts	Rpm	Bhp	Watts	Rpm	Bhp	Watts	Rpm	Bhp	Watts
5,500	682	1.99	1675	760	2.29	1922	832	2.59	2177	901	2.90	2441	965	3.22	2712	1027	3.56	2990
6,000	730	2.38	2005	802	2.68	2257	871	2.99	2516	935	3.31	2783	997	3.63	3057	1056	3.97	3337
6,500	778	2.82	2373	846	3.13	2630	911	3.44	2893	972	3.76	3164	1031	4.09	3440	1087	4.43	3722
7,000	828	3.31	2780	892	3.62	3042	953	3.94	3310	1011	4.26	3583	1067	4.59	3863	1121	4.93	4148
7,500	878	3.84	3227	938	4.15	3494	996	4.48	3766	1051	4.81	4043	1105	5.14	4326	1156	5.49	4613
8,000	928	4.42	3715	985	4.74	3986	1040	5.07	4263	1093	5.40	4544	1144	5.74	4830	1194	6.09	5120
8,500	979	5.05	4245	1033	5.38	4521	1085	5.71	4801	1136	6.05	5086	1185	6.39	5375	1232	6.74	5669
9,000	1030	5.73	4817	1082	6.06	5098	1131	6.40	5382	1180	6.74	5671	1227	7.09	5964	1272	7.44	6260
9,500	1082	6.46	5433	1131	6.80	5718	1178	7.14	6007	1225	7.49	6299	1270	7.84	6595	1313	8.20	6895
10,000	1134	7.25	6093	1180	7.59	6382	1226	7.94	6675	1270	8.29	6971	1313	8.65	7271	1356	9.01	7574

50TJ020, 024 (18 and 20 TONS)* (cont)

Airflow (Cfm)	Available External Static Pressure (in. wg)														
	1.4			1.6			1.8			1.9			2.0		
	Rpm	Bhp	Watts	Rpm	Bhp	Watts	Rpm	Bhp	Watts	Rpm	Bhp	Watts	Rpm	Bhp	Watts
5,500	1086	3.89	3275	1142	4.24	3567	1197	4.59	3864	1223	4.77	4015	1249	4.96	4167
6,000	1112	4.31	3623	1167	4.66	3915	1219	5.01	4213	1245	5.19	4364	1270	5.37	4516
6,500	1142	4.77	4010	1194	5.12	4304	1245	5.47	4602	1270	5.65	4754	1294	5.83	4906
7,000	1173	5.28	4438	1224	5.63	4733	1273	5.98	5033	1296	6.17	5184	1320	6.35	5337
7,500	1207	5.83	4906	1255	6.19	5203	1302	6.55	5504	1326	6.73	5657	1348	6.91	5810
8,000	1242	6.44	5415	1289	6.80	5714	1334	7.16	6018	1357	7.34	6171	1379	7.52	6325
8,500	1279	7.10	5966	1324	7.45	6268	1368	7.82	6573	1389	8.00	6728	1411	8.18	6883
9,000	1317	7.80	6561	1360	8.16	6865	1403	8.53	7173	1424	8.71	7328	1445	8.90	7484
9,500	1356	8.56	7198	1398	8.93	7505	1440	9.29	7815	1460	9.48	7972	1480	9.67	8129
10,000	1397	9.37	7881	1438	9.74	8190	1477	10.11	8503	—	—	—	—	—	—

LEGEND

- Bhp** — Brake Horsepower
- FIOP** — Factory-Installed Option
- Watts** — Input Watts to Motor

*Standard low-medium static drive range for the 020 size is 910 to 1095 rpm. Standard low-medium static drive range for the 024 size is 1002 to 1225 rpm. Alternate high-static drive range for the 020 size is 1069 to 1287. Alternate high-static drive range for the 024 size is 1193 to 1458 rpm. Other rpms require a field-supplied drive.

NOTES:

1. Maximum continuous bhp for the 020 size is 5.90. Maximum continuous bhp for the 024 size is 8.7 (208/230, 575 v) or 9.5 (380, 460 v). The maximum continuous watts for the 020 size is 5180. The maximum continuous watts for the 024 size is 7915

(208/230, 575 v) or 8640 (380, 460 v). Do not adjust motor rpm such that motor maximum bhp and/or watts is exceeded at the maximum operating cfm.

2. Static pressure losses (i.e., EconoMi\$er) must be added to external static pressure before entering Fan Performance table.
3. Interpolation is permissible. Do not extrapolate.
4. Fan performance is based on wet coils, clean filters, and casing losses. See Table 12 for accessory/FIOP static pressure information.
5. Extensive motor and drive testing on these units ensures that the full horsepower and watts range of the motor can be utilized with confidence. Using your fan motors up to the watts or bhp rating shown will not result in nuisance tripping or premature motor failure. Unit warranty will not be affected.
6. Use of a field-supplied motor may affect wiring size. Contact your Carrier representative for details.

Table 10 — Fan Performance — 50TJ028

50TJ028 (25 TONS)*																		
Airflow (Cfm)	Available External Static Pressure (in. wg)																	
	0.2			0.4			0.6			0.8			1.0			1.2		
	Rpm	Bhp	Watts	Rpm	Bhp	Watts	Rpm	Bhp	Watts	Rpm	Bhp	Watts	Rpm	Bhp	Watts	Rpm	Bhp	Watts
7,000	845	3.26	2693	909	3.60	2979	969	3.96	3272	1028	4.32	3574	1083	4.70	3883	1137	5.08	4,200
7,500	896	3.82	3156	956	4.17	3450	1014	4.54	3752	1069	4.91	4060	1123	5.29	4375	1174	5.68	4,698
8,000	948	4.43	3667	1005	4.80	3969	1060	5.17	4278	1112	5.56	4593	1163	5.94	4915	1213	6.34	5,243
8,500	1001	5.11	4226	1054	5.49	4537	1106	5.87	4853	1156	6.26	5175	1205	6.66	5504	1253	7.06	5,838
9,000	1053	5.85	4836	1104	6.23	5155	1154	6.63	5478	1202	7.02	5808	1248	7.43	6142	1294	7.84	6,483
9,500	1106	6.65	5498	1155	7.04	5824	1202	7.44	6155	1248	7.85	6492	1293	8.26	6833	1336	8.68	7,179
10,000	1159	7.52	6214	1206	7.92	6547	1251	8.33	6886	1295	8.74	7229	1338	9.16	7577	1380	9.59	7,929
10,500	1213	8.45	6984	1257	8.86	7325	1300	9.28	7671	1342	9.70	8020	1384	10.13	8375	1424	10.56	8,733
11,000	1266	9.45	7810	1309	9.87	8159	1350	10.29	8511	1391	10.73	8868	1431	11.16	9229	1470	11.60	9,594
11,250	1293	9.97	8245	1334	10.40	8597	1375	10.83	8953	1415	11.26	9313	1454	11.70	9677	1493	12.15	10,045

50TJ028 (25 TONS)* (cont)									
Airflow (Cfm)	Available External Static Pressure (in. wg)								
	1.4			1.6			1.8		
	Rpm	Bhp	Watts	Rpm	Bhp	Watts	Rpm	Bhp	Watts
7,000	1189	5.47	4,524	1239	5.87	4,854	1288	4.91	5191
7,500	1224	6.08	5,026	1272	6.48	5,362	1320	5.56	5703
8,000	1261	6.75	5,577	1307	7.16	5,917	1353	6.26	6263
8,500	1299	7.47	6,177	1344	7.89	6,523	1388	7.02	6873
9,000	1338	8.26	6,828	1382	8.68	7,179	1424	7.85	7534
9,500	1379	9.11	7,530	1421	9.54	7,887	1462	8.74	8247
10,000	1421	10.02	8,286	1461	10.46	8,648	1501	9.70	9014
10,500	1464	11.00	9,096	1503	11.45	9,464	1541	10.73	9835
11,000	1508	12.05	9,963	1546	12.50	10,336	—	—	—
11,250	1530	12.60	10,417	—	—	—	—	—	—

LEGEND

- Bhp** — Brake Horsepower
- FIOF** — Factory-Installed Option
- Watts** — Input Watts to Motor

*Standard low-medium static drive range is 1066 to 1283 rpm. Alternate high-static drive range is 1332 to 1550. Other rpms require a field-supplied drive.

NOTES:

1. Maximum continuous bhp is 10.2 (208/230, 575 v) or 11.8 (380, 460 v) and the maximum continuous watts are 9510 (208/230, 575 v) or 11,000 (380, 460 v). Do not adjust motor rpm such that motor maximum bhp and/or watts is exceeded at the maximum operating cfm.

2. Static pressure losses (i.e., EconoMi\$er) must be added to external static pressure before entering Fan Performance table.
3. Interpolation is permissible. Do not extrapolate.
4. Fan performance is based on wet coils, clean filters, and casing losses. See Table 12 for accessory/FIOF static pressure information.
5. Extensive motor and drive testing on these units ensures that the full horsepower and watts range of the motor can be utilized with confidence. Using your fan motors up to the watts or bhp rating shown will not result in nuisance tripping or premature motor failure. Unit warranty will not be affected.
6. Use of a field-supplied motor may affect wiring size. Contact your Carrier representative for details.

Table 11 — Accessory/FIOP Static Pressure (in. wg) — 50TJ016

COMPONENT	CFM				
	4500	5000	6000	7200	7500
EconoMi\$er	0.04	0.05	0.07	0.09	0.10
Glycol Coil	0.22	0.26	0.35	0.44	0.46
Electric Heat (kW)					
20	0.06	0.07	0.09	0.11	0.12
26/34	0.06	0.07	0.09	0.11	0.12
32	0.06	0.07	0.09	0.11	0.12
35	0.07	0.08	0.12	0.15	0.17
42/56	0.07	0.08	0.12	0.16	0.17
50	0.09	0.10	0.15	0.20	0.21
55	0.07	0.08	0.12	0.15	0.17
56/75	0.09	0.10	0.15	0.20	0.21
80	0.09	0.10	0.15	0.20	0.21

LEGEND

FIOP — Factory-Installed Option

NOTES:

1. The static pressure must be added to external static pressure. The sum and the evaporator entering-air cfm should then be used in conjunction with the Fan Performance tables to determine blower rpm and watts.
2. Heaters are rated at 240 v, 380 v, 480 v, and 600 v.

Table 12 — Accessory/FIOP Static Pressure (in. wg) — 50TJ020-028

COMPONENT	CFM					
	5400	6000	7200	9000	10,000	11,250
EconoMi\$er	0.06	0.07	0.09	0.11	0.12	0.14
Glycol Coil	0.30	0.35	0.44	0.58	0.66	0.77
Electric Heat (kW)						
20, 26/34	0.08	0.09	0.11	0.15	0.17	0.20
32	0.08	0.09	0.11	0.15	0.17	0.20
35, 42/56	0.11	0.12	0.15	0.19	0.21	0.24
55	0.11	0.12	0.15	0.19	0.21	0.24
56/75	0.14	0.15	0.20	0.24	0.26	0.29
80	0.14	0.15	0.20	0.24	0.26	0.29

LEGEND

FIOP — Factory-Installed Option

NOTES:

1. The static pressure must be added to external static pressure. The sum and the evaporator entering-air cfm should then be used in conjunction with the Fan Performance tables to determine blower rpm and watts.
2. Heaters are rated at 240 v, 380 v, and 480 v. There are no 575-v heaters.

Table 13 — MoistureMiser Dehumidification Package Static Pressure Drop (in. wg)

UNIT SIZE 50TJ	UNIT NOMINAL TONS	CFM PER TON		
		300	400	500
016	15	.040	.071	.111
020	18	.058	.102	.160
024	20	.071	.126	.197
028	25	.111	.197	.308

Table 14 — Fan Rpm at Motor Pulley Settings*

UNIT 50TJ	MOTOR PULLEY TURNS OPEN												
	0	1/2	1	1 1/2	2	2 1/2	3	3 1/2	4	4 1/2	5	5 1/2	6
016 (208/230, 380, 460 v)†	††	††	1179	1150	1121	1093	1064	1035	1006	978	949	920	891
016 (208/230, 380, 460 v)**	††	††	1559	1522	1488	1455	1422	1389	1356	1323	1289	1256	1227
016 (575 v)†	††	††	1429	1403	1376	1349	1323	1296	1269	1242	1215	1188	1159
020†	††	††	1095	1077	1058	1040	1021	1002	984	965	947	928	910
020**	††	††	1287	1265	1243	1222	1200	1178	1156	1134	1112	1091	1069
024†	††	††	1225	1209	1187	1165	1143	1120	1098	1076	1053	1031	1002
024**	††	††	1458	1434	1407	1381	1354	1328	1301	1275	1248	1222	1193
028†	††	††	1283	1269	1247	1225	1203	1182	1160	1138	1116	1095	1066
028**	††	††	—	—	1551	1524	1497	1470	1443	1415	1388	1361	1332

*Approximate fan rpm shown.

†Indicates standard drive package.

**Indicates alternate drive package.

††Due to belt and pulley size, pulley cannot be set to this number of turns open.

Base Unit Operation

COOLING, UNITS WITHOUT ECONOMISER — When thermostat calls for cooling, terminals G and Y1 are energized. The indoor (evaporator) fan contactor (IFC), and compressor contactor no. 1 (C1) are energized and evaporator-fan motor, compressor no. 1 and condenser fans start. The condenser-fan motors run continuously while unit is cooling. If the thermostat calls for a second stage of cooling by energizing Y2, compressor contactor no. 2 (C2) is energized and compressor no. 2 starts.

HEATING, UNITS WITHOUT ECONOMISER (If Accessory or Optional Heater is Installed) — Upon a call for heating through terminal W1, IFC and heater contactor no. 1 (HC1) are energized. On units equipped for 2 stages of heat, when additional heat is needed, HC2 is energized through W2.

COOLING UNITS WITH ECONOMISER — When the OAT is above the ECON SP set point and the room thermostat calls for Stage 1 cooling (R to G + Y1), the indoor-fan motors (IFM) is energized and the EconoMi\$er damper modulates to minimum position. The compressor contactor and OFC are energized to start the compressor and outdoor-fan motor (OFM). After the thermostat is satisfied, the damper modulates to the fully closed position when the IFM is deenergized.

When the OAT is below the ECON SP setting and the room thermostat calls for Stage 1 cooling (R to G + Y1), the EconoMi\$er modulates to the minimum position when the IFM is energized. The EconoMi\$er provides Stage 1 of cooling by modulating the return and outdoor air dampers to maintain a 55 F supply air set point. If the supply-air temperature (SAT) is greater than 57 F, the EconoMi\$er modulates open, allowing a greater amount of outdoor air to enter the unit. If the SAT drops below 53 F, the outdoor air damper modulates closed to reduce the amount of outdoor air. When the SAT is between 53 and 57 F, the EconoMi\$er maintains its position.

If outdoor air alone cannot satisfy the cooling requirements of the conditioned space, and the OAT is above the MECH CLG LOCKOUT set point, the EconoMi\$er integrates free cooling with mechanical cooling. This is accomplished by the strategies below.

NOTE: Compressors have a two-minute Minimum On and Minimum Off, which are accomplished by the strategies below.

1. If Y1 is energized, and the room thermostat calls for Y2 (2-stage thermostat), the compressor and OFC are energized. The position of the EconoMi\$er damper is maintained at its current value.
2. If Y1 is energized for more than 20 minutes, and Y2 is not energized (whether or not a 2-stage thermostat is used), the compressor and OFC are energized. The position of the EconoMi\$er damper is maintained at its current value.
3. If Y1 is energized, and compressor no. 1 is already energized (see Step 2) and the room thermostat calls for Y2, compressor no. 1 continues to operate. If Y2 remains energized for more than 20 minutes, compressor no. 2 is energized.

NOTE: Compressor no. 2 cannot be energized unless there is a signal for Y2 from the space thermostat.

4. If compressor no. 2 is energized, and the Y2 signal from the thermostat is satisfied, compressors 1 and 2 are deenergized. Re-asserting Y2 will start compressor no. 1 and (after a 20-minute interstage delay) compressor no. 2.
5. If compressor no. 1 is energized and the thermostat is satisfied, compressor no. 1, the OFM, and IFM are deenergized and the EconoMi\$er modulates closed.

When the OAT is below the MECH CLG LOCKOUT set point, the compressors remain off.

FREEZE PROTECTION THERMOSTAT(S) — A freeze protection thermostat (FPT) is located on the top and bottom of the evaporator coil. It detects frost build-up and turns off the compressor, allowing the coil to clear. Once frost has melted, the compressor can be reenergized by resetting the compressor lockout.

HEATING, UNITS WITH ECONOMISER (If Accessory or Optional Heater is Installed) — When the room thermostat calls for heat, the heating controls are energized as described in the Heating, Units Without EconoMi\$er section. The IFM is energized and the EconoMi\$er damper modulates to the minimum position. When the thermostat is satisfied, the damper modulates closed.

UNITS WITH MOISTUREMISER DEHUMIDIFICATION PACKAGE — When thermostat calls for cooling, terminals G and Y1 and/or Y2 and the compressor contactor C1 and/or C2 are energized. The indoor (evaporator) fan motor (IFM), compressors, and outdoor (condenser) fan motors (OFM) start. The OFMs run continuously while the unit is in cooling. As shipped from the factory, both MoistureMiser dehumidification circuits are always energized.

If MoistureMiser circuit modulation is desired, a field-installed, wall-mounted humidistat is required. If the MoistureMiser humidistat is installed and calls for the MoistureMiser subcooler coil to operate, the humidistat internal switch closes. This energizes the 3-way liquid line solenoid valve coils (LLSV1 for circuit 1 and LLSV2 for circuit 2) of the MoistureMiser circuits, forcing the warm liquid refrigerant of the liquid line to enter the subcooler coils. See Fig. 30.

As the warm liquid passes through the subcooler coils, it is exposed to the cold supply airflow coming off the evaporator coils and the liquid is further cooled to a temperature approaching the evaporator coil leaving-air temperature. The state of the refrigerant leaving the subcooler coils is a highly subcooled liquid refrigerant. The liquid then enters a thermostatic expansion valve (TXV) where the liquid is dropped to the evaporator pressure. The TXVs can throttle the pressure drop of the liquid refrigerant and maintain proper conditions at the compressor suction valves over a wide range of operating conditions. The liquid proceeds to the evaporator coils at a temperature lower than normal cooling operation. This lower temperature is what increases the latent and sensible capacity of the evaporator coils.

The 2-phase refrigerant passes through the evaporators and is changed into a vapor. The air passing over the evaporator coils will become colder than during normal operation as a result of the colder refrigerant temperatures. However, as it passes over the subcooler coils, the air will be warmed, decreasing the sensible capacity and reducing the sensible heat of the rooftop unit.

As the refrigerant leaves the evaporator, the refrigerant passes a subcooler control low-pressure switch (S-LPS1 for circuit 1 or S-LPS2 for circuit 2) in the suction line. This low-pressure switch will deactivate the MoistureMiser package when the suction pressure reaches 60 psig. The subcooler control low-pressure switch is an added safety device to protect against evaporator coil freeze-up during low ambient operation. The subcooler control low-pressure switch will only deactivate the 3-way liquid line solenoid valve in the MoistureMiser circuit. The compressors will continue to run as long as there is a call for cooling, regardless of the position of the subcooler control low-pressure switch. The 3-way solenoid valve and the MoistureMiser package will be reactivated only when the call for cooling has been satisfied, the subcooler control low-pressure switch has closed above 80 psig, and a new call for cooling exists. The crankcase heaters on the scroll compressors provide additional protection for the compressors due to the additional refrigerant charge in the subcooler.

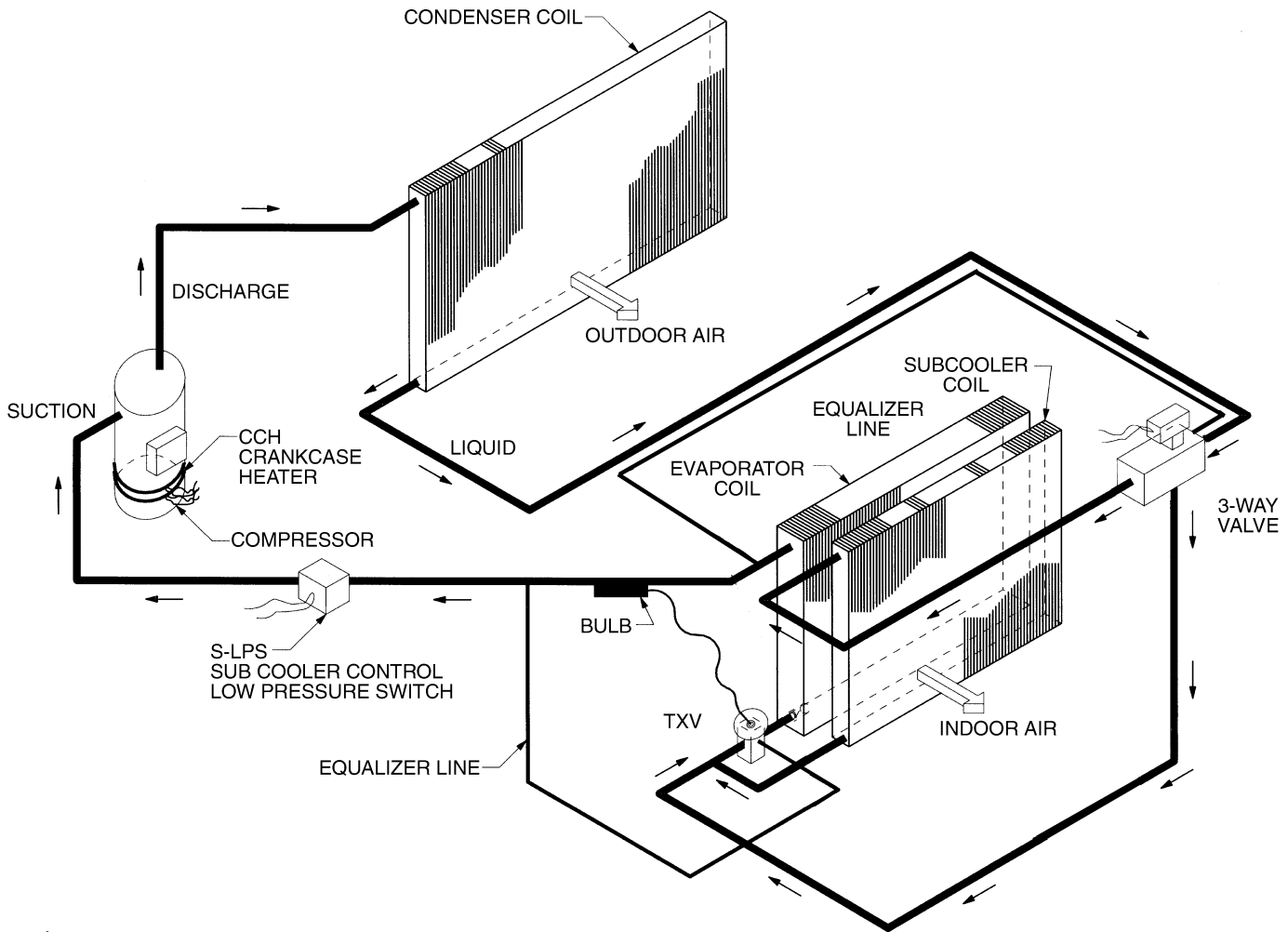

Fig. 30 — MoistureMiser Operation Diagram

When the humidistat is satisfied, the humidistat internal switch opens, cutting power to and deenergizing the LLSVs. The refrigerant is routed back through the evaporators and the sub-cooler coils are removed from the refrigerant loops. When the thermostat is satisfied, C1 and C2 are deenergized and the compressors, IFM, and OFMs shut off. If the thermostat fan selector switch is in the ON position, the IFM will run continuously.

SERVICE

⚠ WARNING

Before performing service or maintenance operations on unit, turn off main power switch to unit. Turn off accessory heater power switch if applicable. Electrical shock could cause personal injury.

Cleaning — Inspect unit interior at beginning of each heating and cooling season and as operating conditions require. Remove unit top panel and/or side panels for access to unit interior.

EVAPORATOR COIL — Clean as required with a commercial coil cleaner.

NOTE: The 50TJ028 unit has a mist eliminator screen attached to the evaporator coil to prevent condensate runoff at high wet-bulb conditions. Check periodically and clean as necessary.

CONDENSER COIL — Clean condenser coil annually and as required by location and outdoor-air conditions. Inspect coil monthly — clean as required.

CONDENSATE DRAIN — Check and clean each year at start of cooling season.

FILTERS — Clean or replace at start of each heating and cooling season, or more often if operating conditions require. Refer to Table 1 for type and size.

NOTE: The 50TJ028 unit requires industrial grade throwaway filters capable of withstanding face velocities up to 625 fpm. Ensure that replacement filters for the 50TJ028 units are rated for 625 fpm.

OUTDOOR-AIR INLET SCREENS — Clean screens with steam or hot water and a mild detergent. Do not use throwaway filters in place of screens.

Lubrication

COMPRESSORS — Each compressor is charged with the correct amount of oil at the factory. Conventional white oil (Sontext 200LT) is used. White oil is compatible with 3GS oil, and 3GS oil may be used if the addition of oil is required. See compressor nameplate for original oil charge. A complete re-charge should be four ounces less than the original oil charge. When a compressor is exchanged in the field it is possible that a major portion of the oil from the replaced compressor may still be in the system. While this will not affect the reliability of the replacement compressor, the extra oil will add rotor drag and increase power usage. To remove this excess oil, an access valve may be added to the lower portion of the suction line at

the inlet of the compressor. The compressor should then be run for 10 minutes, shut down, and the access valve opened until no oil flows. This should be repeated twice to make sure the proper oil level has been achieved.

FAN SHAFT BEARINGS — For size 016 units, bearings are permanently lubricated. No field lubrication is required. For size 020-028 units, the bearings are of the pillow block type and have grease fittings. The bearing opposite the motor end has an extended tube line so it can be lubricated from the motor side. Lubricate the bearings twice annually.

Typical lubricants are given below:

MANUFACTURER	LUBRICANT
Texaco	Regal AFB-2*
Mobil	Mobilplex EP No. 1
Sunoco	Prestige 42
Texaco	Multiflak 2

*Preferred lubricant because it contains rust and oxidation inhibitors.

CONDENSER AND EVAPORATOR-FAN MOTOR BEARINGS — The condenser and evaporator-fan motors have permanently-sealed bearings, so no field lubrication is necessary.

Evaporator Fan Performance Adjustment (Fig. 31-33) — Fan motor pulleys are factory set for speed shown in Table 1.

To change fan speeds:

1. Shut off unit power supply.
2. a. Size 016 Only: Loosen belt by loosening fan motor mounting plate nuts.
b. Size 020-028 Only: Loosen nuts on the 2 carriage bolts in the motor mounting base. Install jacking bolt and plate under motor base (bolt and plate are shipped in installer's packet). See Fig. 33. Using bolt and plate, raise motor to top of slide and remove belt. Secure motor in this position by tightening the nuts on the carriage bolts.
3. Loosen movable-pulley flange setscrew (see Fig. 31).
4. Screw movable flange toward fixed flange to increase speed and away from fixed flange to decrease speed. Increasing fan speed increases load on motor. Do not exceed maximum speed specified in Table 1.

See Table 7 for air quantity limits.

5. Set movable flange at nearest keyway of pulley hub and tighten setscrew. (See Table 1 for speed change for each full turn of pulley flange.)
6. Replace and tighten belts. See Belt Tension Adjustment section on page 26.

To align fan and motor pulleys:

1. Loosen fan pulley setscrews.
2. Slide fan pulley along fan shaft.
3. Make angular alignment by loosening motor from mounting plate.

Evaporator Fan Service and Replacement

50TJ016 UNITS (See Fig. 32)

NOTE: To remove belts only, follow Steps 1-6.

1. Remove filter and supply-air section panels.
2. Remove unit top panel.
3. Loosen carriage nuts A and B holding motor mount assembly to fan scroll side plates.
4. Loosen screw C.
5. Rotate motor mount assembly (with motor attached) as far as possible away from evaporator coil.

6. Remove belt.
7. Rotate motor mount assembly back past original position toward evaporator coil.
8. Remove motor mounting nuts D and E (both sides).
9. Lift motor up through top of unit.
10. Reverse above procedure to reinstall motor.
11. Check and adjust belt tension as necessary.

50TJ020-028 UNITS (See Fig. 33) — The 50TJ020-028 units use a fan motor mounting system that features a slide-out motor mounting plate. To replace or service the motor, slide out the bracket.

1. Remove the evaporator-fan access panel and the heating control access panel.
2. Remove the center post (located between the evaporator fan and heating control access panels) and all screws securing it.
3. Loosen nuts on the two carriage bolts in the motor mounting base.
4. Using jacking bolt under motor base, raise motor to top of slide and remove belt. Secure motor in this position by tightening the nuts on the carriage bolts.
5. Remove the belt drive.
6. Remove jacking bolt and tapped jacking bolt plate.
7. Remove the 2 screws that secure the motor mounting plate to the motor support channel.
8. Remove the 3 screws from the end of the motor support channel that interfere with the motor slide path.
9. Slide out the motor and motor mounting plate.
10. Disconnect wiring connections and remove the 4 mounting bolts.
11. Remove the motor.
12. To install the new motor, reverse Steps 1-11.

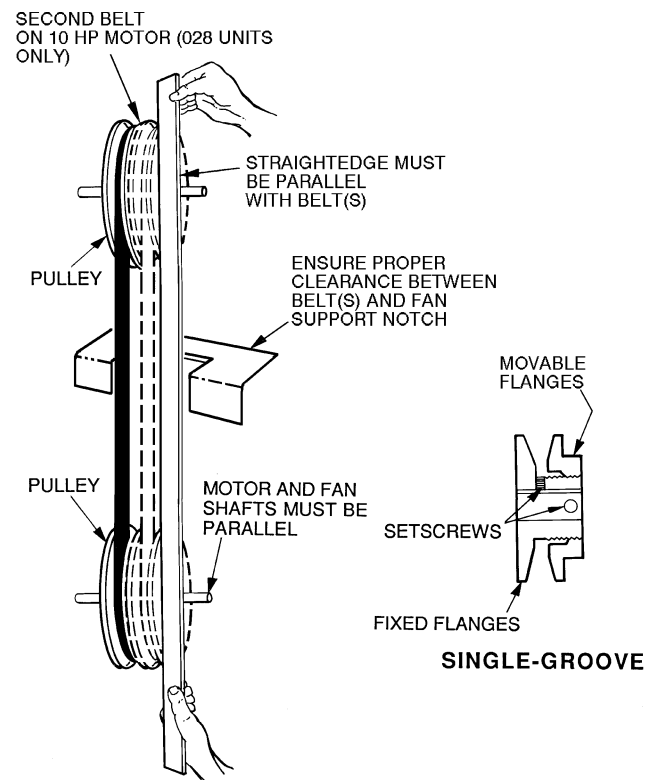

Fig. 31 — Evaporator-Fan Pulley Alignment and Adjustment

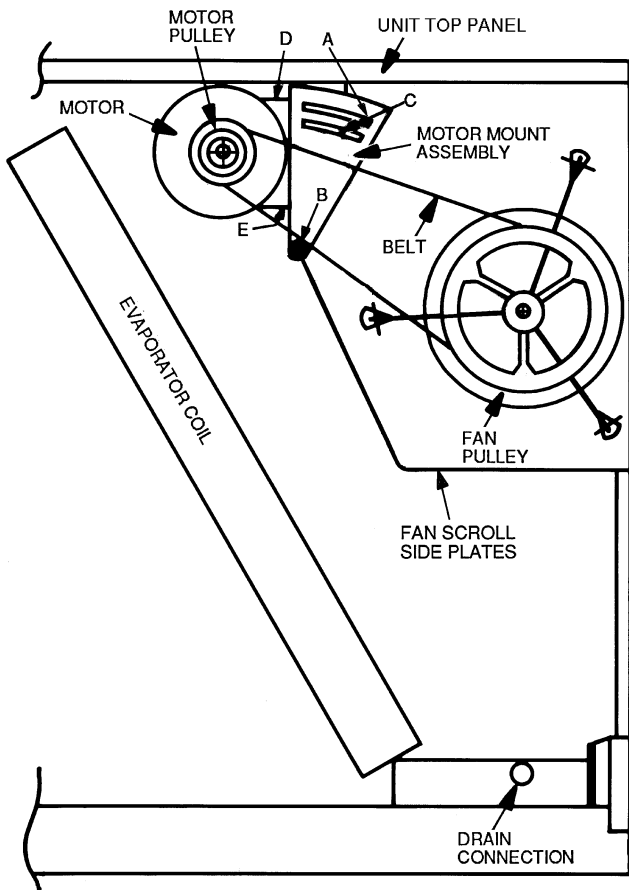
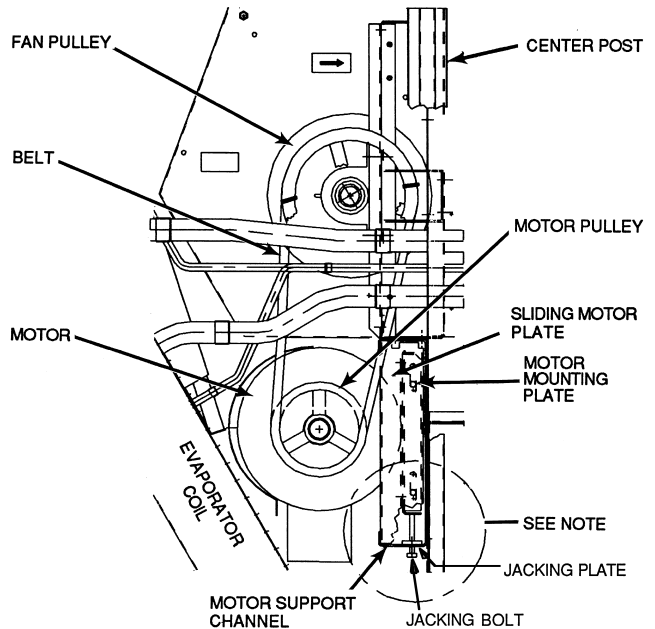

Fig. 32 — 50TJ016 Evaporator-Fan Motor Section

4. Tighten setscrews and replace rubber hubcap to prevent hub from rusting to motor shaft.
5. Fill hub recess with permagum if rubber hubcap is missing.



NOTE: A 3 1/2-in. bolt and threaded plate are included in the installer's packet. They should be added to the motor support channel below the motor mounting plate to aid in raising the motor. The plate part number is 50DP503842. The adjustment bolt is 3/8-16 x 1 3/4 in.-LG.

Fig. 33 — 50TJ020-028 Evaporator-Fan Motor Section

Belt Tension Adjustment — To adjust belt tension:

1. Loosen fan motor bolts.
2. Adjust belt tension:
 - a. Size 016 Units: Move motor mounting plate up or down for proper belt tension (1/2 in. deflection with one finger).
 - b. Size 020-028 Units: Turn motor jacking bolt to move motor mounting plate up or down for proper belt tension (3/8 in. deflection at midspan with one finger [9 lb force]).
3. Tighten nuts.
4. Adjust bolts and nut on mounting plate to secure motor in fixed position.

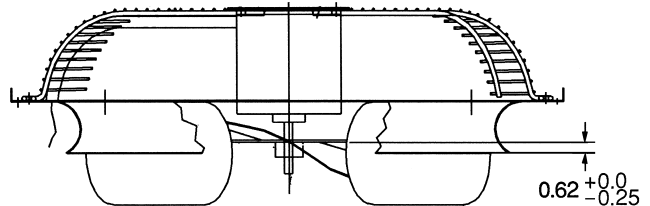

NOTE: Dimensions are in inches).

Fig. 34 — Condenser-Fan Adjustment, 50TJ016,020

Condenser-Fan Adjustment

50TJ016,020 UNITS (Fig. 34)

1. Shut off unit power supply.
2. Remove access panel(s) closest to the fan to be adjusted.
3. Loosen fan hub setscrews.
4. Adjust fan height on shaft using a straightedge placed across the fan orifice.
5. Tighten setscrews and replace panel(s).
6. Turn on unit power.

50TJ024,028 UNITS (Fig. 35)

1. Shut off unit power supply.
2. Remove fan top-grille assembly and loosen fan hub screws.
3. Adjust fan height on unit, using a straightedge placed across the fan orifice.

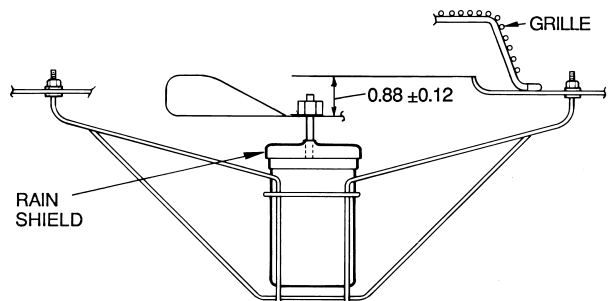

NOTE: Dimensions are in inches.

Fig. 35 — Condenser-Fan Adjustment, 50TJ024,028

EconoMi\$er Adjustment

LED INDICATION — The EconoMi\$er controller features an onboard diagnostic LED (light-emitting diode) that flashes to indicate its status. See Table 15 for flash codes. The controller also has terminal connections (REM LED) for remotely mounting an LED, if desired. The flash code priorities are as follows:

1. On/Off or continuous flash
2. Critical fault
3. Non-critical fault

If any sensors are opened, shorted, or removed, the EconoMi\$er determines whether the failure is critical or non-critical and flashes the appropriate code. If a non-critical sensor fault occurs (i.e., outdoor air humidity), the EconoMi\$er automatically reconfigures its control strategy to a more appropriate mode. If a critical sensor fault occurs (i.e., supply air sensor), the EconoMi\$er reverts to a safe mode of operation until the sensor problem is resolved.

MANUAL CONFIGURATION PUSHBUTTON — The EconoMi\$er controller also features an onboard button (CONFIG) to help troubleshoot the system. See Fig. 16. The button can perform 3 different functions.

Pressing the CONFIG button for more than three seconds, but less than ten seconds and then releasing will start the automatic test procedure. The damper will modulate fully open, wait, and modulate closed. This process takes three minutes to complete. Use this feature to determine if the actuator can be commanded.

If the CONFIG button is pressed and held for ten seconds and less than 30 seconds then released, the EconoMi\$er controller reconfigures its mode of operation based on the sensors that are connected and functioning normally, and cancels the automatic test procedure.

If the EconoMi\$er controller recognized a non-critical sensor fault, and flashed a code (i.e., FLASH 6, outdoor air humidity sensor fault) the FLASH CODE will be cleared, and normal operation begins. Ensure faulty sensor is removed before clearing faults.

If the EconoMi\$er controller recognizes a critical sensor fault, and flashes a code (i.e., FLASH 4, discharge air thermostat fault) the FLASH code will not be cleared, and the EconoMi\$er will remain in the safe operation mode. The

sensor fault must be corrected to enable EconoMi\$er to revert to normal operation.

If the CONFIG button is pressed and held for more than 30 seconds and released, the EconoMi\$er controller will enable the enthalpy comparison strategy (with outdoor air enthalpy and return air enthalpy sensors installed).

Power Failure — Dampers have a spring return. In event of power failure, dampers will return to fully closed position until power is restored. *Do not manually operate damper motor.*

Refrigerant Charge — Amount of refrigerant charge is listed on unit nameplate and in Table 1. Refer to Carrier GTAC II; Module 5; Charging, Recovery, Recycling, and Reclamation section for charging methods and procedures. Unit panels must be in place when unit is operating during charging procedure.

NOTE: Do not use recycled refrigerant as it may contain contaminants.

NO CHARGE — Use standard evacuating techniques. After evacuating system, weigh in the specified amount of refrigerant (refer to Table 1).

LOW CHARGE COOLING — Using cooling charging chart (see Fig. 36), add or remove refrigerant until conditions of the chart are met. Note that charging chart is different from those normally used. An accurate pressure gage and temperature-sensing device is required. Charging is accomplished by ensuring the proper amount of liquid subcooling. Measure liquid line pressure at the liquid line service valve using pressure gage. Connect temperature sensing device to the liquid line near the liquid line service valve and insulate it so that outdoor ambient temperature does not affect reading.

TO USE THE COOLING CHARGING CHART — Use the above temperature and pressure readings, and find the intersection point on the cooling charging chart. If intersection point on chart is above line, add refrigerant. If intersection point on chart is below line, carefully recover some of the charge. Re-check suction pressure as charge is adjusted. **NOTE:** Indoor-air CFM must be within normal operating range of unit. All outdoor fans must be operating.

The TXV (thermostatic expansion valve) is set to maintain between 15 and 20 degrees of superheat at the compressors. The valves are factory set and should not require re-adjustment.

Table 15 — EconoMi\$er Control Module Flash Code Identification

	FLASH CODE	CAUSE	ACTION TAKEN BY ECONOMI\$ER
Critical Fault	Constant On	Normal operation	Normal operation.
	Constant Off	No power	No operation.
	Continuous Flash	CONFIG button pushed and held between 3 and 9 seconds	Outdoor air damper is stroked fully open, then closed (automatic test procedure takes 3 minutes to complete).
	Flash One	Control board fault	System shutdown.
	Flash Two	Thermostat fault (i.e., Y2 without Y1)	System shutdown until corrected.
	Flash Three	Actuator fault	Revert to mechanical cooling only.
	Flash Four	Discharge air thermistor fault	Continue operation with damper at minimum position. Revert to mechanical cooling only.
	Flash Five	Outdoor air temperature sensor fault	Continue operation with damper at minimum position. Disable mechanical cooling lockout.
	Flash Six	Outdoor air humidity sensor fault	Continue operation with dry bulb or dry bulb differential switchover.
	Flash Seven	Return air temperature sensor fault	Continue operation with single enthalpy EconoMi\$er switchover or dry bulb EconoMi\$er switchover (without humidity sensor).
Non-Critical Fault	Flash Eight	Return air humidity sensor fault	Continue operation with single enthalpy, differential dry bulb, or dry bulb EconoMi\$er switchover.
	Flash Nine	Carbon Dioxide (CO ₂) sensor fault	Continue operation without ventilation control.
	Flash Ten	Onboard adjustment potentiometer fault	Continue operation with default potentiometer settings.

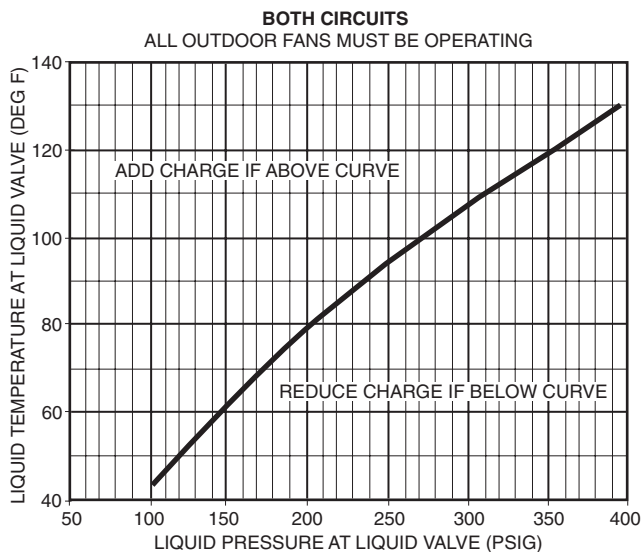

Fig. 36 — Cooling Charging Chart

MOISTUREMISER SYSTEM CHARGING — The system charge for units with the MoistureMiser option is greater than that of the standard unit alone. The charge for units with this option is indicated on the unit nameplate drawing. To charge systems using the MoistureMiser Dehumidification package, fully evacuate, recover, and re-charge the system to the nameplate specified charge level. To check or adjust refrigerant charge on systems using the MoistureMiser Dehumidification package, charge per the standard subcooling charts. The sub-cooler **MUST** be deenergized to use the charging charts. The charts reference a liquid pressure (psig) and temperature at a point between the condenser coil and the subcooler coil. A tap is provided on the unit to measure liquid pressure entering the subcooler (leaving the condenser).

Filter Drier — Replace whenever refrigerant system is exposed to atmosphere.

Protective Devices

COMPRESSOR PROTECTION

Overcurrent — Each compressor has internal line break motor protection, except the circuit no. 1 on the 50TJ028 unit. Compressor no. 1 on the 50TJ028 unit uses an electronic module located with the compressor junction box, to provide motor protection. This electronic module monitors winding and discharge temperatures. If these temperatures reach the trip values, the module interrupts the control line and causes the compressor to switch off.

Crankcase Heater — Only the 50TJ028 unit and units with the optional MoistureMiser Dehumidification system are equipped with a 70-watt crankcase heater to prevent absorption of liquid refrigerant by oil in the crankcase when the compressor is idle. The crankcase heater is energized whenever there is a main power to the unit and the compressor is not energized.

IMPORTANT: After prolonged shutdown or servicing, energize the crankcase heaters for 24 hours before starting the compressors.

Compressor Lockout — If any of the safeties (high-pressure, low-pressure, freeze protection thermostat, compressor internal thermostat) trip, or if there is loss of power to the compressors, the CLO (compressor lockout) will lock the compressors off. To reset, manually move the thermostat setting.

EVAPORATOR FAN MOTOR PROTECTION — A manual reset, calibrated trip, magnetic circuit breaker protects against overcurrent. Do not bypass connections or increase the size of the breaker to correct trouble. Determine the cause and correct it before resetting the breaker.

CONDENSER-FAN MOTOR PROTECTION — Each condenser-fan motor is internally protected against overtemperature.

HIGH- AND LOW-PRESSURE SWITCHES — If either switch trips, or if the compressor overtemperature switch activates, that refrigerant circuit will be automatically locked out by the CLO. To reset, manually move the thermostat setting.

FREEZE PROTECTION THERMOSTAT (FPT) — An FPT is located on the top and bottom of the evaporator coil. It detects frost build-up and turns off the compressor, allowing the coil to clear. Once the frost has melted, the compressor can be reenergized.

Relief Devices — All units have relief devices to protect against damage from excessive pressures (e.g., fire). These devices protect the high and low side.

Control Circuit, 24-V — This control circuit is protected against overcurrent by a 3.2-amp circuit breaker. Breaker can be reset. If it trips, determine cause of trouble before resetting.

Replacement Parts — A complete list of replacement parts may be obtained from any Carrier distributor upon request.

EconoMi\$er LEDs — The EconoMi\$er control module has an LED for diagnostic purposes. The flash code identification is shown in Table 15.

Optional Hinged Access Doors — When the optional service package is ordered or the if the hinged access doors option is ordered, the unit will be provided with external and internal hinged access doors to facilitate service.

Four external hinged access doors are provided. All external doors are provided with 2 large 1/4 turn latches with folding bail-type handles. (Compressor access doors have one latch.) A single door is provided for filter and drive access. One door is provided for control box access. The control box access door is interlocked with the non-fused disconnect which must be in the OFF position to open the door. Two doors are provided for access to the compressor compartment.

Two internal access doors are provided inside the filter/drive access door. The filter access door (on the left) is secured by 2 small 1/4 turn latches with folding bail-type handles. This door must be opened prior to opening the drive access door. The drive access door is shipped with 2 sheet metal screws holding the door closed. Upon initial opening of the door, these screws may be removed and discarded. The door is then held shut by the filter access door, which closes over it.

SCHEMATIC

ELECTRIC HEAT		
	208/240 v Amps	200/230 v kW
A	71.3/82.3	25.7/34.2
B	117/135	42.2/56.1
C	156/180	56.2/74.8

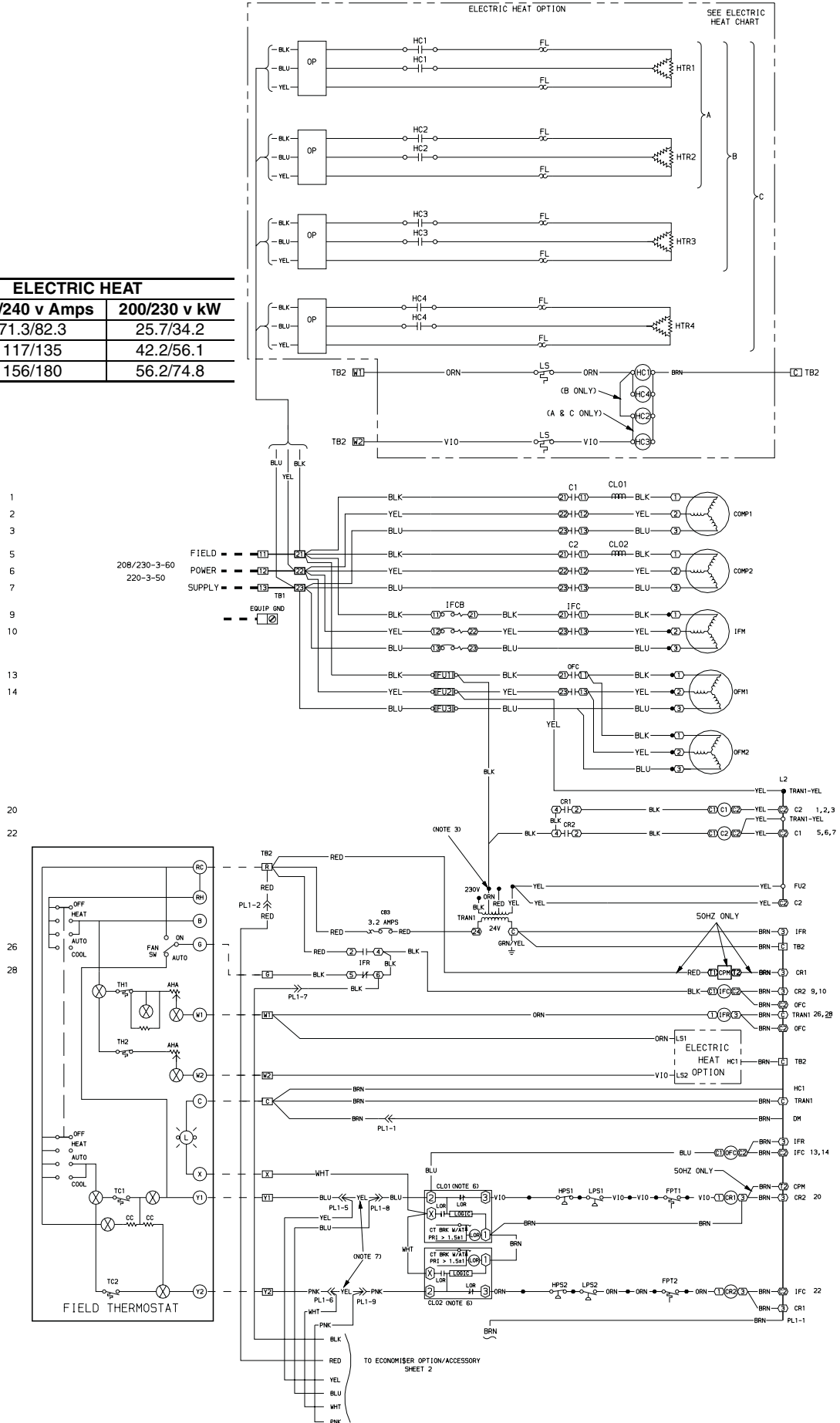

Fig. 37 — Typical Wiring Schematic (50TJ024, 208/230-3-60 Shown)

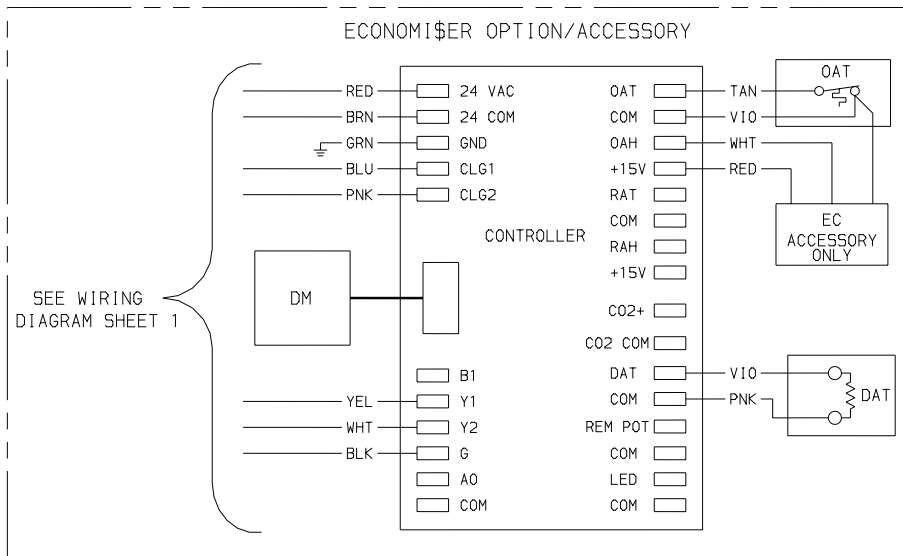
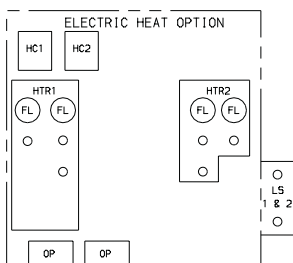
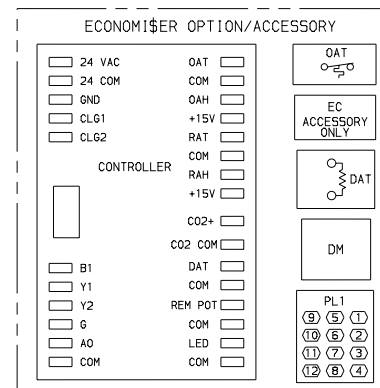
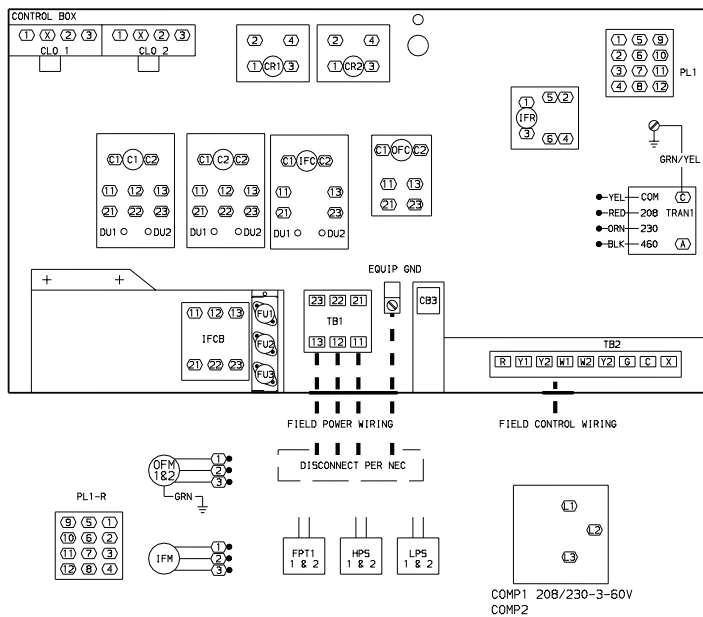
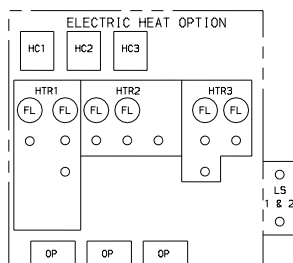

Fig. 37 — Typical Wiring Schematic (50TJ024, 208/230-3-60 Shown) (cont)

COMPONENT ARRANGEMENT



(A)



(B)

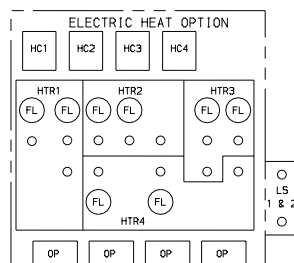

(C)









Fig. 38 — Typical Component Arrangement (50TJ024 Shown)

LEGEND AND NOTES FOR FIG. 37 AND 38

LEGEND

AHA	— Adjustable Heat Anticipator
BRK W/AT	— Breaks with Amp Turns
C	— Contactor, Compressor
CB	— Circuit Breaker
CC	— Cooling Compensator
CH	— Crankcase Heater
CLO	— Compressor Lockout
COMP	— Compressor Motor
CR	— Control Relay
DAT	— Discharge Air Thermistor
DM	— Damper Motor
DU	— Dummy Terminal
EC	— Enthalpy Control
EQUIP	— Equipment
FL	— Fuse Link
FLA	— Full Load Amps
FPT	— Freeze Protection Thermostat
FU	— Fuse

GND	— Ground
HC	— Heater Contactor
HPS	— High-Pressure Switch
HTR	— Heater
IFC	— Indoor-Fan Contactor
IFCB	— Indoor-Fan Circuit Breaker
IFM	— Indoor-Fan Motor
IFR	— Indoor-Fan Relay
L	— Light
LOR	— Lockout Relay
LPS	— Low-Pressure Switch
LS	— Limit Switch
NEC	— National Electrical Code
OAT	— Outdoor-Air Thermostat
OFC	— Outdoor-Fan Contactor
OFM	— Outdoor-Fan Motor
OP	— Overcurrent Protection
PL	— Plug Assembly
PRI	— Primary

TB	— Terminal Block
TC	— Thermostat Cooling
TH	— Thermostat Heating
TRAN	— Transformer
	Terminal (Marked)
	Terminal (Unmarked)
	Terminal Block
	Splice
	Factory Wiring
	Field Control Wiring
	Option/Accessory Wiring
	To indicate common potential only; not to represent wiring.

NOTES:

1. Compressor and fan motor(s) thermally protected; 3-phase motors protected against primary single-phasing conditions.
2. If any of the original wire furnished must be replaced, it must be replaced with type 90 C wire or its equivalent.
3. TRAN1 is wired for 230 v (60 Hz) or 220 v (50 Hz) operation. If unit is 208 v, disconnect the black wires from the ORN TRAN wire and reconnect to the RED TRAN wire, apply wirenuts to wires.
5. IFCB must trip amps is equal to or less than 140% FLA.
6. The CLO locks out the compressor to prevent short cycling on compressor overload and safety devices. Before replacing CLO, check these devices.
7. Jumpers are omitted when unit is equipped with EconoMiSer.
8. Number(s) indicates the line location of used contacts. A bracket over (2) numbers signifies a single-pole, double-throw contact. An underlined number signifies a normally closed contact. Plain (no line) number signifies a normally open contact.

TROUBLESHOOTING

Refer to Tables 16-18 for troubleshooting details.

Table 16 — Cooling Service Analysis

PROBLEM	CAUSE	REMEDY
Compressor and condenser fan will not start.	Power failure.	Call power company.
	Fuse blown or circuit breaker tripped.	Replace fuse or reset circuit breaker.
	Defective thermostat, contactor, transformer, or control relay.	Replace component.
	Insufficient line voltage.	Determine cause and correct.
	Incorrect or faulty wiring.	Check wiring diagram and rewire correctly.
	Thermostat setting too high.	Lower thermostat setting below room temperature.
Compressor will not start but condenser fan runs.	Faulty wiring or loose connections in compressor circuit.	Check wiring and repair or replace.
	Compressor motor burned out, seized, or internal overload open.	Determine cause. Replace compressor.
	Defective overload.	Determine cause and replace.
	Compressor locked out	Determine cause for safety trip and reset lockout.
	One leg of 3-phase power dead.	Replace fuse or reset circuit breaker. Determine cause.
Compressor cycles (other than normally satisfying thermostat).	Refrigerant overcharge or undercharge.	Recover refrigerant, evacuate system, and recharge to nameplate.
	Defective compressor.	Replace and determine cause.
	Insufficient line voltage.	Determine cause and correct.
	Blocked condenser.	Determine cause and correct.
	Defective overload.	Determine cause and replace.
	Defective thermostat.	Replace thermostat.
	Faulty condenser-fan motor.	Replace.
Restriction in refrigerant system.	Locate restriction and remove.	
Compressor operates continuously.	Dirty air filter.	Replace filter.
	Unit undersized for load.	Decrease load or increase unit size.
	Thermostat set too low.	Reset thermostat.
	Low refrigerant charge.	Locate leak, repair, and recharge.
	Air in system.	Recover refrigerant, evacuate system, and recharge.
	Condenser coil dirty or restricted.	Clean coil or remove restriction.
Excessive head pressure.	Dirty air filter.	Replace filter.
	Dirty condenser coil.	Clean coil.
	Refrigerant overcharged.	Recover excess refrigerant.
	Faulty TXV.	1. Check TXV bulb mounting and secure tightly to suction line. 2. Replace TXV if stuck open or closed.
	Air in system.	Recover refrigerant, evacuate system, and recharge.
Condenser air restricted or air short-cycling.	Determine cause and correct.	
Head pressure too low.	Low refrigerant charge.	Check for leaks, repair, and recharge.
	Restriction in liquid tube.	Remove restriction.
Excessive suction pressure.	High heat load.	Check for source and eliminate.
	Faulty TXV.	1. Check TXV bulb mounting and secure tightly to suction line. 2. Replace TXV if stuck open or closed.
	Refrigerant overcharged.	Recover excess refrigerant.
Suction pressure too low.	Dirty air filter.	Replace filter.
	Low refrigerant charge.	Check for leaks, repair, and recharge.
	Metering device or low side restricted.	Remove source of restriction.
	Faulty TXV.	1. Check TXV bulb mounting and secure tightly to suction line. 2. Replace TXV if stuck open or closed.
	Insufficient evaporator airflow.	Increase air quantity. Check filter and replace if necessary.
	Temperature too low in conditioned area.	Reset thermostat.
	Field-installed filter drier restricted.	Replace.

LEGEND

TXV — Thermostatic Expansion Valve

Table 17 — EconoMi\$er Troubleshooting

PROBLEM	POTENTIAL CAUSE	REMEDY
Damper Does Not Open	Indoor (Evaporator) Fan is Off	Check to ensure that 24 vac is present at Terminal C1 (Common Power) on the IFC (Indoor [Evaporator] Fan Contactor) or that 24 vac is present at the IFO (Indoor [Evaporator] Fan On) terminal. Check whether 24 vac is present at PL6-1 (red wire) and/or PL6-3 (black wire). If 24 vac is not present, check wiring (see unit label diagram). Check proper thermostat connection to G on the connection board.
	No Power to EconoMi\$er Controller	Check to ensure that 24 vac is present across Terminals 24 VAC and 24 V COM on the EconoMi\$er control. If 24 vac is not present, check wiring (see unit label diagram). If 24 vac is present, STATUS light should be on constantly.
	No Power to G Terminal	If IFM is on, check to ensure 24 vac is present on G Terminal of the EconoMi\$er controller. If 24 vac is not present, check wiring (see unit label diagram).
	Controller Fault	If STATUS light is flashing one flash, the EconoMi\$er controller is experiencing a fault condition. Cycle power to the controller. If condition continues, replace the EconoMi\$er controller.
	Thermostat Fault	If STATUS light is flashing two flashes, the EconoMi\$er controller senses that the thermostat is wired incorrectly. Check wiring between the thermostat and the connection board in the electrical panel. The fault condition is caused by Y2 being energized before Y1.
	Actuator Fault	Check the wiring between the EconoMi\$er controller and the actuator. Hold CONFIG button between 3 and 10 seconds to verify the actuator's operation. (This process takes 3 minutes to complete.)
EconoMi\$er Operation Limited to Minimum Position	Minimum Position Set Incorrectly	Verify that the MIN POS (%) is set greater than zero. Adjust MIN POS (%) to 100% to verify operation, and then set to correct setting.
	EconoMi\$er Changeover Set Point Set Too High or Too Low	Set at correct value. See Table 5.
	Discharge Air Thermistor Faulty	If STATUS light is flashing 4 flashes, Discharge Air Thermistor is faulty. Check wiring or replace sensor.
	Outdoor Air Temperature Sensor Faulty	If STATUS light is flashing 5 flashes, Outdoor Air Temperature Sensor is faulty. Check wiring or replace sensor.
Damper Position Less than Minimum Position Set Point	Supply Air Low Limit Strategy Controlling	The supply-air temperature is less than 45 F, causing the minimum position to be decreased. Refer to the Start-Up instructions. Verify correct setting of MIN POS (%). If correct, EconoMi\$er is operating correctly.
Damper Does Not Return to Minimum Position	CO ₂ Ventilation Strategy Controlling	If a CO ₂ sensor is being used, and the damper position is greater than minimum position, the ventilation control strategy is controlling. Refer to The Start-Up instructions. EconoMi\$er is operating correctly.
Damper Does Not Close on Power Loss	Damper Travel is Restricted	Check to ensure the damper is not blocked.

LEGEND

IFM — Indoor Fan Motor
PL — Plug

Table 18 — MoistureMiser Dehumidification Subcooler Service Analysis

PROBLEM	CAUSE	REMEDY
Subcooler will not energize	No power to subcooler control transformer.	Check power source. Ensure all wire connections are tight.
	No power from subcooler control transformer to liquid line three way valve.	1. Fuse open; check fuse. Ensure continuity of wiring. 2. Subcooler control low pressure switch open. Cycle unit off and allow low-pressure switch to reset. Replace switch if it will not close. 3. Transformer bad; check transformer.
	Liquid line three-way valve will not operate.	1. Solenoid coil defective; replace. 2. Solenoid valve stuck closed; replace.
Subcooler will not deenergize	Liquid Line three-way valve will not close.	Valve is stuck open; replace.
Low system capacity	Low refrigerant charge or frosted coil.	1. Check charge amount. See system charging section. 2. Evaporator coil frosted; check and replace subcooler control low pressure switch if necessary.

SERVICE TRAINING

Packaged Service Training programs are an excellent way to increase your knowledge of the equipment discussed in this manual, including:

- Unit Familiarization
- Installation Overview
- Maintenance
- Operating Sequence

A large selection of product, theory, and skills programs are available, using popular video-based formats and materials. All include video and/or slides, plus companion book.

Classroom Service Training which includes “hands-on” experience with the products in our labs can mean increased confidence that really pays dividends in faster troubleshooting and fewer callbacks. Course descriptions and schedules are in our catalog.

CALL FOR FREE CATALOG 1-800-962-9212

Packaged Service Training Classroom Service Training

START-UP CHECKLIST

MODEL NO.: _____ SERIAL NO.: _____

DATE: _____ TECHNICIAN: _____

PRE-START-UP:

- VERIFY THAT ALL PACKING MATERIALS HAVE BEEN REMOVED FROM UNIT
- VERIFY INSTALLATION OF INDOOR FAN MOTOR ADJUSTMENT BOLT (016 UNITS) OR ADJUSTMENT BOLT AND PLATE (020-028 UNITS)
- VERIFY INSTALLATION OF ECONOMISER HOOD
- VERIFY THAT CONDENSATE CONNECTION IS INSTALLED PER INSTRUCTIONS
- VERIFY THAT ALL ELECTRICAL CONNECTIONS AND TERMINALS ARE TIGHT
- CHECK THAT FILTERS AND SCREENS ARE CLEAN AND IN PLACE
- VERIFY THAT UNIT IS LEVEL
- CHECK FAN WHEEL AND PROPELLER FOR LOCATION IN HOUSING/ORIFICE, AND VERIFY SETSCREW IS TIGHT
- VERIFY THAT FAN SHEAVES ARE ALIGNED AND BELTS ARE PROPERLY TENSIONED
- VERIFY THAT SCROLL COMPRESSOR IS ROTATING IN THE CORRECT DIRECTION
- VERIFY THAT CRANKCASE HEATER HAS BEEN ENERGIZED FOR 24 HOURS (SIZE 028 AND UNITS WITH OPTIONAL MOISTUREMISER DEHUMIDIFICATION SYSTEM ONLY)

START-UP:

ELECTRICAL

SUPPLY VOLTAGE L1-L2 _____ L2-L3 _____ L3-L1 _____
COMPRESSOR AMPS — COMPRESSOR NO. 1 L1 _____ L2 _____ L3 _____
— COMPRESSOR NO. 2 L1 _____ L2 _____ L3 _____
SUPPLY FAN AMPS _____ EXHAUST FAN AMPS _____
ELECTRIC HEAT AMPS (IF SO EQUIPPED) L1 _____ L2 _____ L31 _____

TEMPERATURES

OUTDOOR-AIR TEMPERATURE _____ F DB (Dry-Bulb)
RETURN-AIR TEMPERATURE _____ F DB _____ F WB (Wet-Bulb)
COOLING SUPPLY AIR _____ F
ELECTRIC HEAT SUPPLY AIR (IF SO EQUIPPED) _____ F

PRESSURES

REFRIGERANT SUCTION CIRCUIT NO. 1 _____ PSIG CIRCUIT NO. 2 _____ PSIG
REFRIGERANT DISCHARGE CIRCUIT NO. 1 _____ PSIG CIRCUIT NO. 2 _____ PSIG

- VERIFY REFRIGERANT CHARGE USING CHARGING CHART ON PAGE 28.

GENERAL

- ECONOMISER MINIMUM VENT AND CHANGEOVER SETTINGS TO JOB REQUIREMENTS
- VERIFY INSTALLATION OF ALL OPTIONS AND ACCESSORIES

CUT ALONG DOTTED LINE

CUT ALONG DOTTED LINE

Free Manuals Download Website

<http://myh66.com>

<http://usermanuals.us>

<http://www.somanuals.com>

<http://www.4manuals.cc>

<http://www.manual-lib.com>

<http://www.404manual.com>

<http://www.luxmanual.com>

<http://aubethermostatmanual.com>

Golf course search by state

<http://golfingnear.com>

Email search by domain

<http://emailbydomain.com>

Auto manuals search

<http://auto.somanuals.com>

TV manuals search

<http://tv.somanuals.com>