

Service and Maintenance Instructions For Sizes 050-125, Series 110

NOTE: Read the entire instruction manual before starting the installation.

SAFETY CONSIDERATIONS

Installing and servicing heating equipment can be hazardous due to gas and electrical components. Only trained and qualified personnel should install, repair, or service heating equipment.

Untrained personnel can perform basic maintenance functions such as cleaning and replacing air filters. All other operations must be performed by trained service personnel. When working on heating equipment, observe precautions in the literature, tags, and labels attached to or shipped with the unit and other safety precautions that may apply.

Follow all safety codes, including NFPA 54/ANSI Z223.1-1988, National Fuel Gas Code. Wear safety glasses and work gloves. Have fire extinguisher available during start-up and adjustment procedures and service call.

Recognize safety information. This is the safety-alert symbol. When you see this symbol on the unit and in instructions or manuals, be alert to the potential for personal injury.

Understand the signal word—**DANGER**, **WARNING**, or **CAUTION**. These words are used with the safety-alert symbol. **DANGER** identifies the most serious hazards which will result in severe personal injury or death. **WARNING** signifies hazards that could result in personal injury or death. **CAUTION** is used to identify unsafe practices, which would result in minor personal injury or product and property damage.

⚠ WARNING

Never store anything on, near, or in contact with, the furnace, such as:

1. Spray or aerosol cans, rags, brooms, dust mops, vacuum cleaners, or other cleaning tools.
2. Soap powders, bleaches, waxes or other cleaning compounds, plastic or plastic containers, gasoline, kerosene, cigarette lighter fluid, dry cleaning fluids, or other volatile fluids.
3. Paint thinners and other painting compounds, paper bags or other paper products.

Failure to follow this warning can cause corrosion of the heat exchanger, fire, personal injury, or death.

⚠ WARNING

The ability to properly perform maintenance on this equipment requires certain expertise, mechanical skills, tools, and equipment. If you do not possess these, do not attempt to perform any maintenance on this equipment other than those procedures recommended in the User's Manual. **FAILURE TO FOLLOW THIS WARNING COULD RESULT IN POSSIBLE DAMAGE TO THIS EQUIPMENT, SERIOUS PERSONAL INJURY, OR DEATH.**

CARE AND MAINTENANCE

For continuing high performance and to minimize possible equipment failure, it is essential that maintenance be performed annually on this equipment. Consult your local dealer for maintenance and the availability of a maintenance contract.

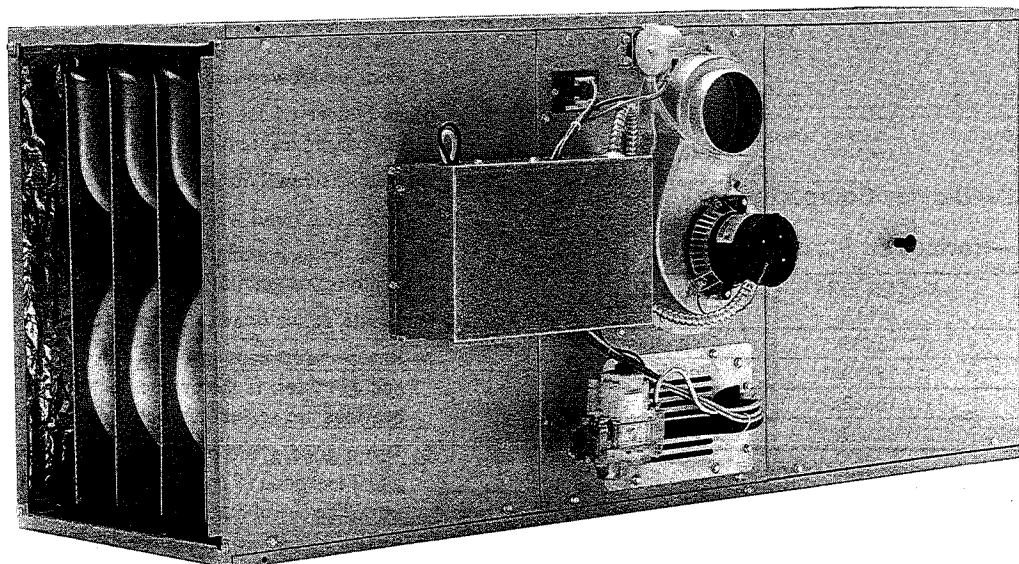

Fig. 1—Model 58EFA Horizontal Furnace

A91314

Manufacturer reserves the right to discontinue, or change at any time, specifications or designs without notice and without incurring obligations.

▲ WARNING

Turn OFF the gas and electrical supplies to the unit before performing any maintenance or service. Follow the operating instructions on the label attached to the furnace. Failure to follow this warning could result in personal injury.

The minimum maintenance that should be performed on this equipment is as follows:

1. Check and clean or replace air filter each month, or as required. (See Step 1.)
2. Check blower motor and wheel for cleanliness and lubrication each heating and cooling season. Clean and lubricate as necessary. (See Step 2.)
3. Check electrical connections for tightness and controls for proper operation each heating season. Service as necessary.
4. Check for blockages of vent pipe.

▲ CAUTION

As with any mechanical equipment, personal injury could result from sharp metal edges, etc. Be careful when removing parts, panels, or components.

Step 1—Air Filter Cleaning and Replacement

The air filter arrangement may vary depending on the application. Each furnace may be supplied with a permanent, washable filter and wire filter retainer option. If so, the filter is normally located in the return-air plenum opening before the blower. (See Fig. 2.)

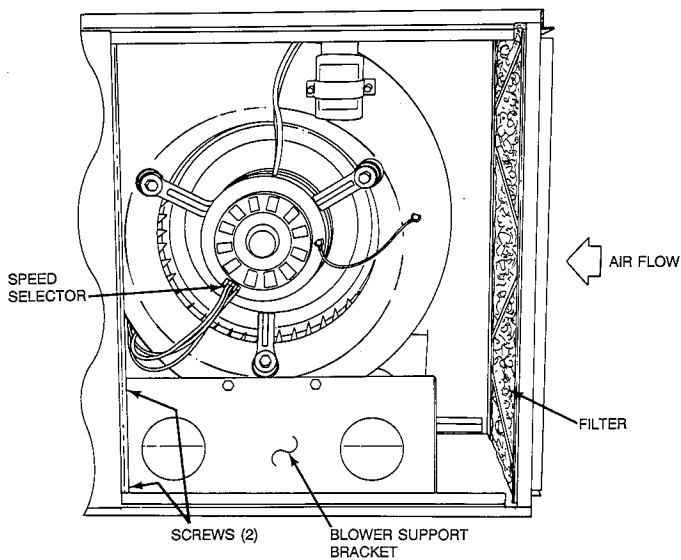

Fig. 2—Blower Compartment

A91175

Table 1—Horizontal Furnace Filters

FURNACE SIZE (INPUT BTUH)	FILTER SIZE (IN.)	FILTER TYPE
50,000	(1) 13x23x1	Cleanable
75,000	(1) 13x23x1	Cleanable
100,000	(1) 16x23x1	Cleanable
125,000	(1) 20x23x1	Cleanable

▲ CAUTION

Never operate unit without a filter or with filter access door removed. Failure to follow this warning could result in a fire or personal injury.

To clean or replace the filters, proceed as follows:

1. Turn OFF electrical supply to unit.
2. Remove blower access door located at inlet (return air) end of furnace; 4 screws must be removed.
3. Bend wire filter retainer until it clears furnace flange and swing it toward the blower.
4. Remove filter from furnace. If filter is torn, replace it.
5. Furnaces may be equipped with permanent, washable filters. Clean these filters by spraying cold tap water through filter in opposite direction of airflow. A mild liquid detergent may be used if necessary.
6. Rinse filters and let dry. Oiling or coating of filters is not recommended or required for factory-supplied filters.
7. Reinstall filters with cross-mesh binding facing blower.
8. Replace blower access door and reinstall 4 screws.
9. Turn ON electrical supply to furnace.

Step 2—Blower Motor and Wheel Maintenance

For long life, economy, and high efficiency; clean accumulated dirt and grease from blower wheel and motor annually.

The following items should be performed by a qualified service technician:

Some motors have prelubricated, sealed bearings and require no lubrication. These motors can be identified by the absence of oil ports on each end of the motor. For motors with oil ports, lubricate as follows:

Lubricate motor every 5 years if motor is used for intermittent operation (thermostat FAN switch in AUTO position), or every 2 years if motor is in continuous operation (thermostat FAN switch in ON position).

Clean and lubricate as follows:

1. Turn OFF electrical supply to unit.
2. Remove blower access door; 4 screws must be removed.
3. Remove blower assembly as follows:
 - a. Remove 4 screws securing front blower support bracket and remove bracket. (See Fig. 2.)
 - b. Using a 3/8-in. ratchet with a 3-in. extension, reach through 4-in. diameter holes in rear blower support bracket and remove 2 screws securing bracket to blower shelf. (See Fig. 2.)
 - c. Disconnect motor leads from motor speed selector. (See Fig. 2.)
 - d. Remove blower assembly from unit.
4. Mark blower wheel location on shaft before disassembly to insure proper reassembly.
5. Loosen setscrew holding blower wheel on motor shaft.
6. Disconnect ground wire from blower housing.
7. Remove bolts holding motor mount to blower housing and slide motor and mount out of housing.
8. Lubricate motor (when oil ports are provided).
 - a. Remove dust caps or plugs from oil ports located at each end of motor. If motor does not have these caps or plugs, bearings are sealed and need no further lubrication.
 - b. Use a good grade of SAE 20 nondetergent motor oil and add 1 teaspoon (5 cc, 3/16 oz, or 16 to 25 drops) in each oil port. The use of other types or grades of oil will damage the motor. Excessive oiling can cause premature bearing failures.
 - c. Allow time for total quantity of oil to be absorbed by each bearing.

- d. After oiling motor, wipe excess oil from motor housing.
- e. Replace dust caps or plugs on oil ports.
9. Remove blower wheel from housing.
 - a. Mark blower wheel orientation and cutoff plate location to insure proper reassembly.
 - b. Remove screws securing cutoff plate and remove cutoff plate from housing.
 - c. Remove blower wheel from housing.
10. Clean blower wheel and motor using a vacuum with soft brush attachment. Be careful not to disturb balance weights (clips) on blower wheel vanes. Do not drop or bend wheel as balance will be affected.
11. Reassemble blower by reversing items 9.a. through 9.c. Ensure wheel is positioned for proper rotation.
12. Reassemble motor and blower by reversing items 3 through 7. Reconnect motor ground wire.

⚠ CAUTION

Ensure the motor is properly positioned in the blower housing. The motor oil ports must be at a minimum of 30° above the horizontal centerline of the motor after the blower assembly has been reinstalled in the furnace.

13. Reinstall blower assembly in furnace.
14. Connect electrical leads to motor speed selector; **do not force leads.**
15. Turn ON electrical supply and check for proper rotation and speed changes between heating and cooling.

Step 3—Cleaning Heat Exchangers and Burners

The following items should be performed by a qualified service technician:

If it becomes necessary to clean the heat exchanger because of carbon deposits, soot, etc., proceed as follows:

NOTE: Deposits of soot and carbon indicate a problem exists that needs to be corrected. Action must be taken to correct the problem.

1. Turn OFF gas and electrical supplies to furnace.
2. Using a backup wrench, disconnect gas supply at ground joint union. Remove gas pipe from gas valve.
3. Disconnect electrical wiring from gas valve.
4. Remove burner/manifold assembly as follows:
 - a. Remove air inlet plate/burner removal cover.
 - b. Remove manifold retention plate from front of unit.
 - c. Loosen screws in manifold retention plate at rear of unit.
 - d. Disconnect wiring to ignition electrode/flame sensor.
 - e. Remove burner/manifold assembly from unit.
5. Place burner/manifold assembly on flat work surface and clean burner ports. Use a soft brush to loosen dirt, then vacuum.
6. Using a small rubber mallet, gently tap each burner opening to loosen any debris in heat exchanger cells.
7. Brush each heat exchanger cell using a nylon heat exchanger brush with a long, flexible handle.
8. Vacuum each heat exchanger cell and burner box with a crevice tool attachment.
9. Check position and alignment of pilot assembly to burners and ignition electrode to ignition hood. (See Fig. 3.)
10. Reinstall burner/manifold assembly and front manifold retention plate.

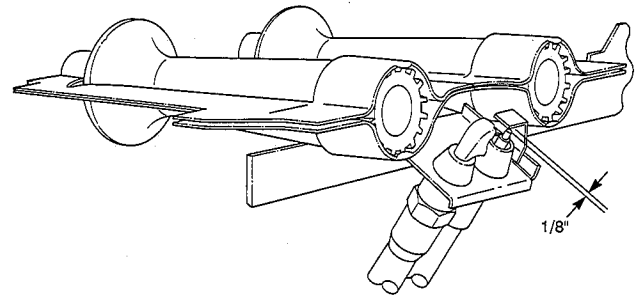

Fig. 3—Position of Pilot Assembly to Burners

A91347

11. Tighten screws securing rear manifold retention plate.
 12. Reconnect wiring to ignition electrode/flame sensor.
 13. Reinstall air inlet plate/burner removal cover.
 14. Using wiring diagram (Fig. 7.) reconnect wiring to gas valve.
 15. Apply joint compound (pipe dope) sparingly to male ends of gas pipe and reinstall gas pipe in gas valve.
- NOTE:** Joint compound must be resistant to the action of propane gas.
16. Reconnect ground joint union.
 17. Turn ON gas and electrical supplies to furnace.
 18. Check gas supply line for leaks.

⚠ WARNING

Never use matches, candles, flame, or other sources of ignition to check for gas leakage. Use a soap-and-water solution. Failure to follow this warning could result in a fire, personal injury, or death.

19. Check furnace operation through 2 complete operating cycles. Look through vent openings in burner enclosure to check burners. Main burner flames should be clear blue, almost transparent. Pilot flame should be soft blue in color, well defined, and must provide good impingement of the ignition electrode/flame sensor. Pilot flame should extend above burner carryover port to provide proper burner ignition. (See Fig. 3, 4, and 5.)

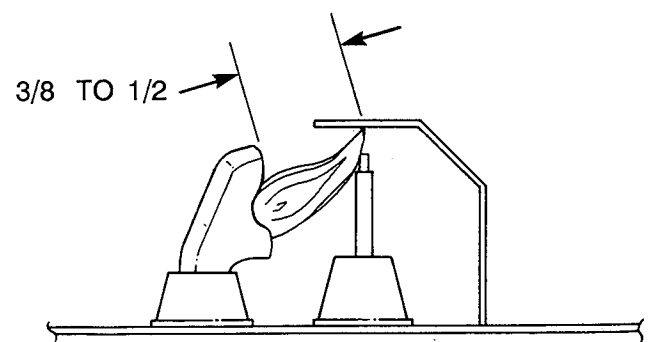

Fig. 4—Position of Pilot to Ignition Electrode/Flame Sensor

A91348

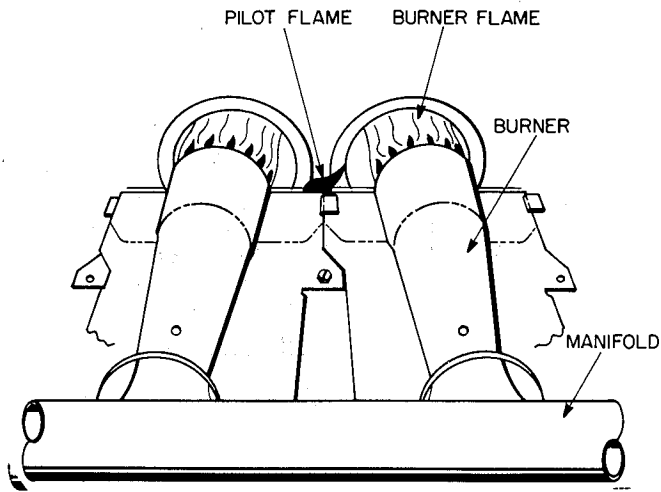

Fig. 5—Pilot and Burner Flames

A84076

Step 4—Pilot Assembly

Check the pilot assembly and clean if necessary at the beginning of each heating season. The pilot flame should be high enough for proper impingement of the ignition electrode/flame sensor and to

light the burners. Remove any accumulation of soot and carbon from the flame sensor. Check spark ignition electrode gap. (See Fig. 3, 4 and 5.)

Step 5—Electrical Controls and Wiring

NOTE: There may be more than 1 electrical supply to the unit.

Refer to Fig. 6 for field application wiring and Fig. 7 for unit wiring. With power disconnected to the unit, check all electrical connections for tightness. Tighten all screws on electrical connections. If any smokey or burned connections are found, disassemble the connection, clean all parts, strip wire, and reassemble properly and securely.

Reconnect electrical power to the unit and observe unit through 1 complete operating cycle. Electrical controls are difficult to check without proper instrumentation. A good voltmeter is needed to check for correct operation of controls and wiring.

If the furnace fails to operate, check the following items before calling for service:

1. Is the thermostat set correctly to "call for heat?"
2. Are the electrical and gas supplies ON?
3. Are the filters clean?

Refer to the Trouble Analysis chart in this manual for further information.

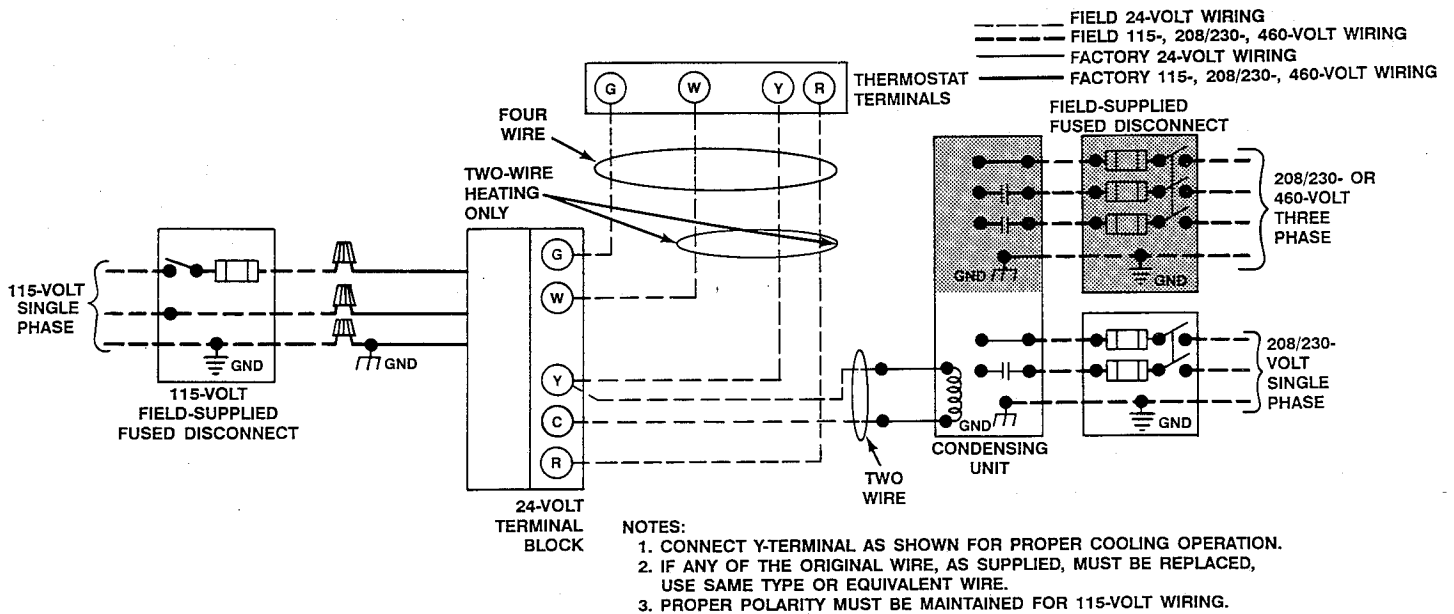
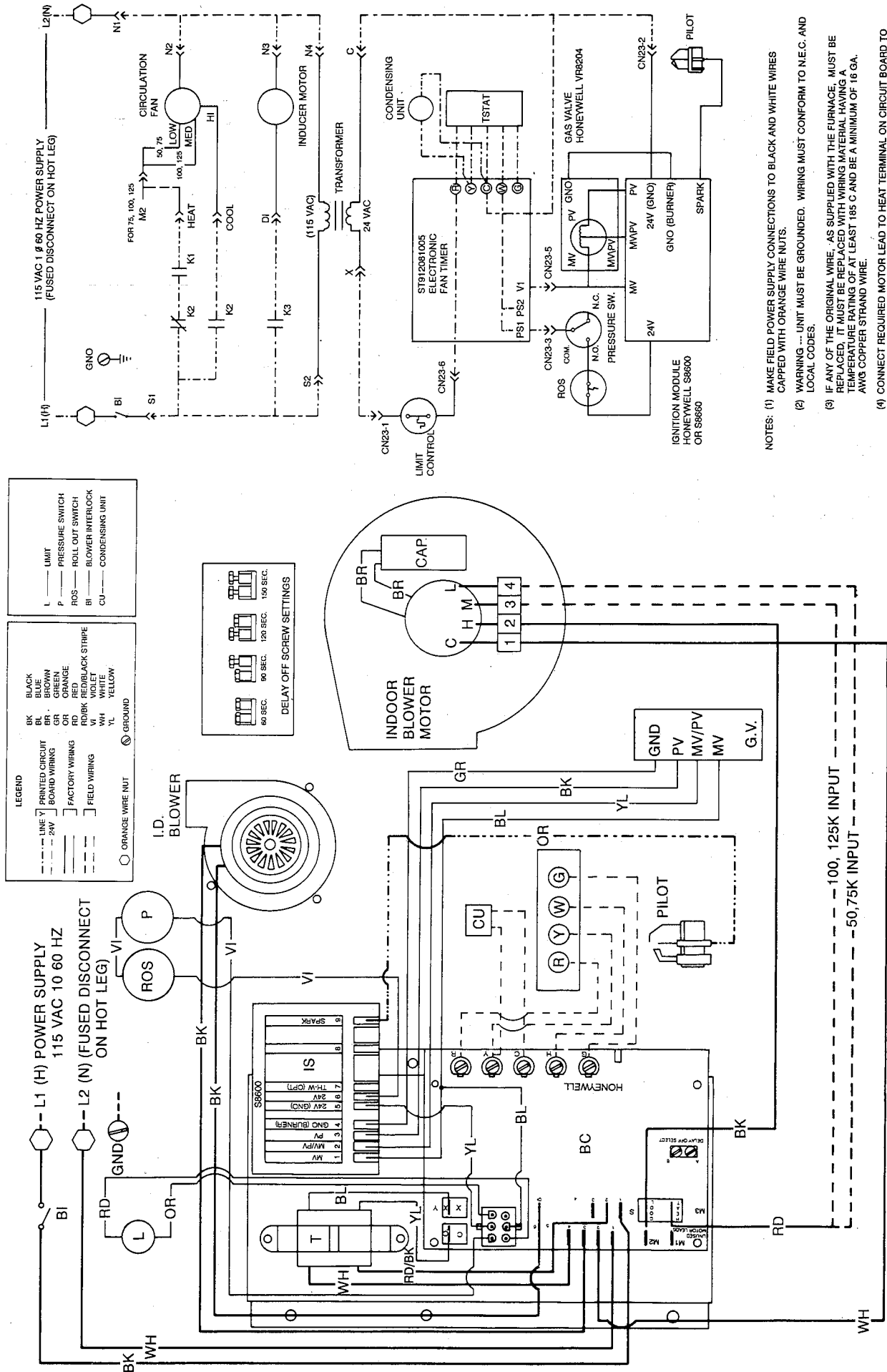

Fig. 6—Heating and Cooling Application Wiring Diagram

A91338



LEGEND

—	PRINTED CIRCUIT BOARD WIRING	BK	BLACK
- - -	24V	BL	BLUE
---	FACTORY WIRING	BR	BROWN
---	FIELD WIRING	GR	GREEN
○	ORANGE WIRE NUT	OR	ORANGE
○	GROUND	RD/BK	RED/BLACK STRIPE
○	GROUND	VI	VIOLET
○	GROUND	WH	WHITE
○	GROUND	YL	YELLOW

I	LIMIT
P	PRESSURE SWITCH
ROS	ROLL OUT SWITCH
BI	BLOWER INTERLOCK
CU	CONDENSING UNIT

DELAY OFF SCREW SETTINGS

90 SEC.	120 SEC.	150 SEC.
---------	----------	----------

- NOTES:**
- (1) MAKE FIELD POWER SUPPLY CONNECTIONS TO BLACK AND WHITE WIRES CAPPED WITH ORANGE WIRE NUTS.
 - (2) WARNING --- UNIT MUST BE GROUNDED. WIRING MUST CONFORM TO M.E.C. AND LOCAL CODES.
 - (3) IF ANY OF THE ORIGINAL WIRE, AS SUPPLIED WITH THE FURNACE, MUST BE REPLACED, IT MUST BE REPLACED WITH WIRING MATERIAL HAVING A TEMPERATURE RATING OF AT LEAST 185 C AND BE A MINIMUM OF 16 GA. AWG COPPER STRAND WIRE.
 - (4) CONNECT REQUIRED MOTOR LEAD TO HEAT TERMINAL ON CIRCUIT BOARD TO DELIVER A TEMPERATURE RISE WITHIN THE RANGE SPECIFIED ON THE RATING PLATE. CONNECT UNUSED MOTOR LEADS TO THE "M1 & M2" TERMINALS.

Fig. 7—Wiring Diagram

A91349

Trouble Analysis Chart

SYMPTOM	PROBABLE CAUSE	REMEDY
Pilot will not light.	No spark at electrode.	Check 115-v electrical supply to furnace. Check spark gap. Check draft inducer motor, repair as necessary. Check pressure switch; contacts must be closed (vent piping must be free from obstructions). Also, check for kinks or obstructions in pressure tubing. Check for accumulation of moisture or dirt on electrode ceramic; clean if necessary. Check for cracked ceramic; replace electrode if necessary. Check for loose or broken wiring at and between control box and electrode. Check for 24-v electrical supply to ignition control box. If 24v are supplied to box, and above steps have been completed; replace ignition control box.
	Spark shorting out to main burner.	Align electrode tip away from burner—maintain proper spark gap.
	No gas at pilot assembly.	Check if pilot gas valve is opening. Check for broken or loose wiring connections. If no deficiency is found, replace gas valve.
Burners will not ignite.	No 115-v electrical supply to furnace.	Check fuse, circuit breaker, and wiring.
	No 24-v electrical supply to control circuit.	Check transformer; replace if necessary.
	Miswired or loose connections.	Check all wiring and connections; repair as necessary.
	No gas at main burners.	Check if main gas valve is opening. Check for broken or loose wiring connections. If no deficiency is found, replace gas valve.
	Flame rollout shutoff switch activated.	Check venting system for blockage; correct improper venting condition.
	Flame probe or connecting lead shorted or open.	Correct electrical shorting or open circuit as required.
	Dirty pilot (yellow flame).	Clean pilot orifice.
Inadequate heating.	Gas input to furnace too low.	Check gas pressure at manifold. Check gas meter for input. If too low, increase manifold pressure and/or replace orifices with correct size.
	Limit switch cycles main burners.	Dirty air filters; clean or replace. Blower speed too low; adjust to higher speed. Restricted supply- or return-air ductwork or registers; repair as necessary. Incorrect heat anticipator setting; determine proper setting and adjust as necessary.
	Furnace undersized for application.	Replace with properly sized furnace.
Aldehyde odors (CO), sooting or floating flame.	Incomplete combustion (poor flame characteristics).	Lack of combustion air—see installation instructions. Overfired furnace; reduce input or replace orifices. Check vent piping for restriction; clean as necessary. Cracked heat exchanger; replace.

Free Manuals Download Website

<http://myh66.com>

<http://usermanuals.us>

<http://www.somanuals.com>

<http://www.4manuals.cc>

<http://www.manual-lib.com>

<http://www.404manual.com>

<http://www.luxmanual.com>

<http://aubethermostatmanual.com>

Golf course search by state

<http://golfingnear.com>

Email search by domain

<http://emailbydomain.com>

Auto manuals search

<http://auto.somanuals.com>

TV manuals search

<http://tv.somanuals.com>