

# Installation, Start-Up and Service Instructions

## CONTENTS

	Page
<b>SAFETY CONSIDERATIONS</b> .....	1-9
General .....	1
<b>RECEIVING AND INSTALLATION</b> .....	10-22
<b>Step 1 — Check Equipment</b> .....	10
• IDENTIFY UNIT	
• INSPECT SHIPMENT	
<b>Step 2 — Provide Unit Support</b> .....	10
• ROOF CURB	
• SLAB MOUNT	
• FLUSH MOUNT	
<b>Step 3 — Field Fabricate Ductwork</b> .....	10
<b>Step 4 — Provide Clearances</b> .....	10
<b>Step 5 — Rig and Place Unit</b> .....	10
• UNITS WITHOUT BASE RAIL	
• UNITS WITH OPTIONAL BASE RAIL	
<b>Step 6 — Connect Condensate Drain</b> .....	13
<b>Step 7 — Install Flue Hood</b> .....	13
<b>Step 8 — Install Gas Piping</b> .....	13
<b>Step 9 — Install Duct Connections</b> .....	16
• CONFIGURING UNITS FOR DOWNFLOW (VERTICAL) DISCHARGE	
<b>Step 10 — Install Electrical Connections</b> .....	18
• HIGH-VOLTAGE CONNECTIONS	
• SPECIAL PROCEDURES FOR 208-V OPERATION	
• CONTROL VOLTAGE CONNECTIONS; NON-INTEGRATED CONTROL MOTOR (NON-ICM) UNITS	
• CONTROL VOLTAGE CONNECTIONS; INTEGRATED CONTROL MOTOR (ICM) UNITS	
• HEAT ANTICIPATOR SETTING	
• TRANSFORMER PROTECTION	
<b>PRE-START-UP</b> .....	22,23
<b>START-UP</b> .....	23-44
<b>MAINTENANCE</b> .....	44-47
<b>TROUBLESHOOTING</b> .....	48-50
<b>START-UP CHECKLIST</b> .....	CL-1

**NOTE TO INSTALLER** — Before the installation, READ THESE INSTRUCTIONS CAREFULLY AND COMPLETELY. Also, make sure the User's Manual and Replacement Guide are left with the unit after installation. The furnace is NOT to be used for temporary heating of buildings or structures under construction.

## SAFETY CONSIDERATIONS

Installation and servicing of air-conditioning equipment can be hazardous due to system pressure and electrical components. Only trained and qualified personnel should install, repair, or service air-conditioning equipment.

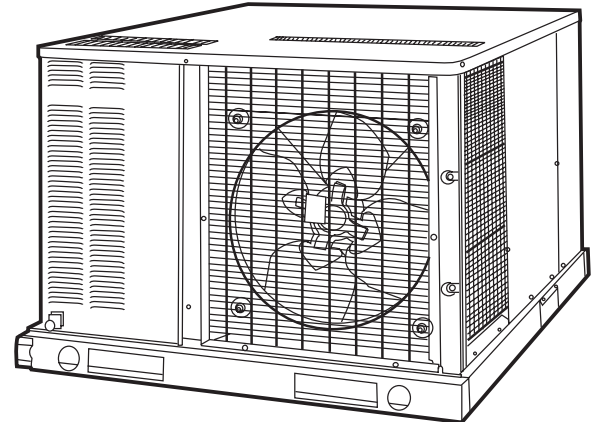

**Fig. 1 — Unit 48SX Shown With Optional Base Rail**

Untrained personnel can perform basic maintenance functions of cleaning coils and filters. All other operations should be performed by trained service personnel. When working on air-conditioning equipment, observe precautions in the literature, tags and labels attached to the unit, and other safety precautions that may apply.

Follow all safety codes. Wear safety glasses and work gloves. Use quenching cloth for unbrazing operations. Have fire extinguisher available for all brazing operations.

### ⚠ WARNING

Improper installation, adjustment, alteration, service, maintenance, or use can cause carbon monoxide poisoning, fire, or an explosion which can result in personal injury or unit damage. Consult a qualified installer, service agency, or gas supplier for information or assistance. The qualified installer or agency must use only factory-authorized kits or accessories when modifying this product.

### ⚠ WARNING

Before performing service or maintenance operations on unit, turn off gas supply *then* unit main power switch. Electrical shock could cause personal injury.

**General** — The 48SS,SX units (see Fig. 1) are fully self-contained, combination Category I gas heating/electric cooling units designed for outdoor installation. See Fig. 2-9 (pages 2-9) for unit dimensions. All unit sizes have discharge openings for both horizontal and downflow configurations, and are factory shipped with all 4 duct openings covered. Units may be installed either on a rooftop or a ground-level cement slab. See Fig. 10 for roof curb dimensions.

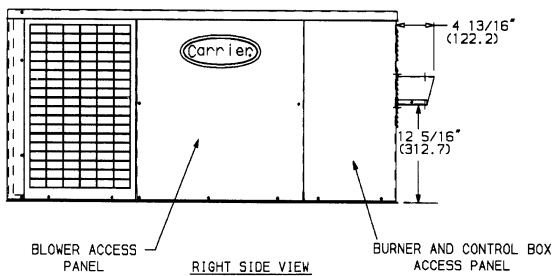

**REQ'D CLEARANCES FOR SERVICING. in. (mm)**

Duct panel	0
Unit top	36 (914)
Side opposite ducts	36 (914)
Compressor access (Except for NEC requirements)	36 (914)

**REQ'D CLEARANCES TO COMBUSTIBLE MAT'L. in. (mm)**

Maximum extension of overhangs	48 (1219)
Unit top	14 (356)
Duct side of unit	2 (51)
Side opposite ducts	14 (356)
Bottom of unit	0
Flue panel	36 (914)

**NEC REQ'D CLEARANCES. in. (mm)**

Between units, control box side	42 (1067)
Unit and ungrounded surfaces, control box side	36 (914)
Unit and block or concrete walls and other grounded surfaces, control box side	42 (1067)

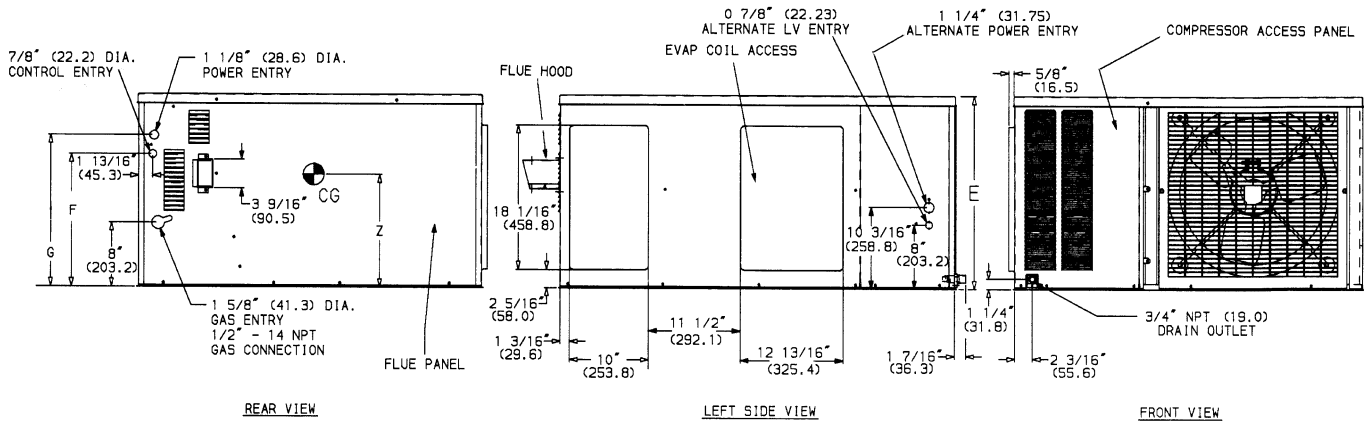
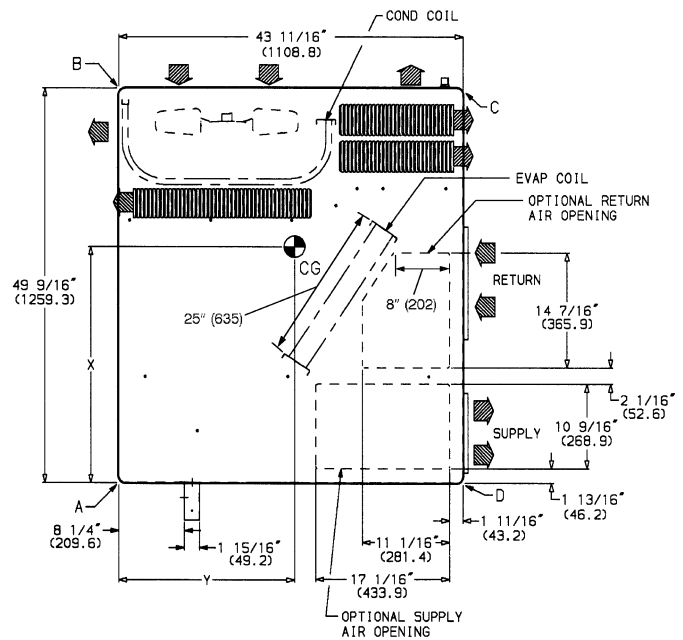

UNIT	ELECTRICAL CHARACTERISTICS	UNIT WEIGHT		CORNER WEIGHT (lb/kg)				UNIT HEIGHT (in./mm)	
		lb	kg	A	B	C	D	E	
48SS180040	208/230-1-60	272	123	81/37	62/28	76/35	53/24	24.1/613	
48SS024040	208/230-1-60	303	138	97/44	43/20	123/56	40/18	24.1/613	
48SS024060	208/230-1-60	315	143	100/45	46/21	126/57	43/20	24.1/613	
48SS030040	208/230-1-60, 208/230-3-60	320	145	100/45	47/21	126/57	47/21	24.1/613	
48SS030060/080	208/230-1-60, 208/230-3-60	332	149	103/46	50/22	129/58	50/23	24.1/613	
48SS036060/080	208/230-1-60, 208/230-3-60, 460-3-60	336	153	86/39	76/35	111/50	63/29	24.1/613	
48SS036100/120	208/230-1-60, 208/230-3-60, 460-3-60	348	158	89/40	79/36	114/52	66/30	24.1/613	
48SS042060/080	208/230-1-60, 208/230-3-60, 460-3-60	375	170	95/43	86/39	119/54	75/34	28.1/714	
48SS042100/120	208/230-1-60, 208/230-3-60, 460-3-60	387	176	98/45	89/40	122/55	78/35	28.1/714	

UNIT	F in./mm	G in./mm	CENTER OF GRAVITY in./mm		
			X	Y	Z
48SS018040	16 9/16/420.7	18 15/16/481.0	25.07/637	20.59/523	10.85/276
48SS024040			27.07/688	23.35/593	
48SS024060			26.98/685	23.27/591	
48SS030040			26.71/678	23.46/596	
48SS030060/080			27.15/689	22.36/568	
48SS036060/080			27.50/698	22.48/571	
48SS036100/120	20 9/16/522.3	22 15/16/582.6	27.40/696	22.44/570	12.7/321
48SS042060/080			27.01/686	22.44/570	
48SS042100/120			26.94/684	22.44/570	

**LEGEND**

- CG — Center of Gravity
- COND — Condenser
- LV — Low Voltage
- MAT'L — Material
- NEC — National Electrical Code
- REQ'D — Required

**NOTES:**

- Clearances must be maintained to prevent recirculation of air from outdoor-fan discharge.
- Adequate clearance around air openings into combustion chamber must be provided.

**Fig. 2 — 48SS018-042 Without Base Rail, Unit Dimensions**

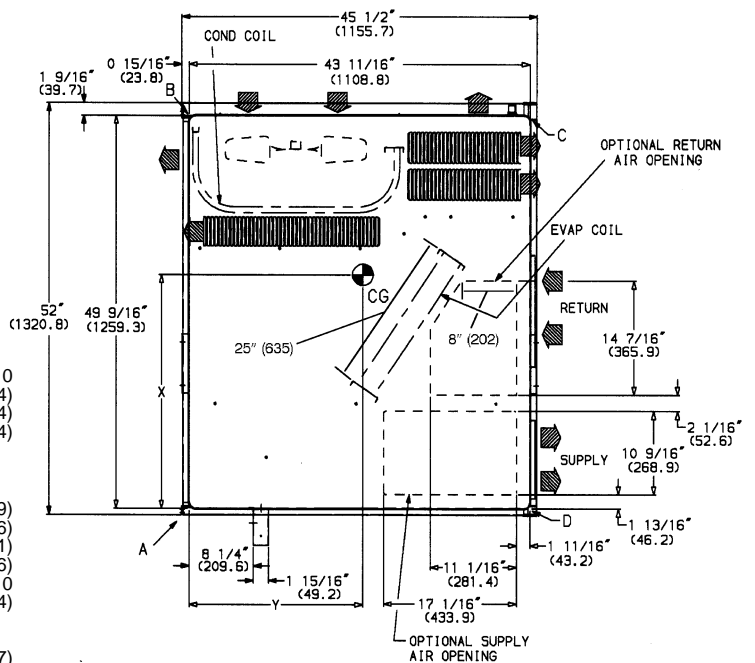
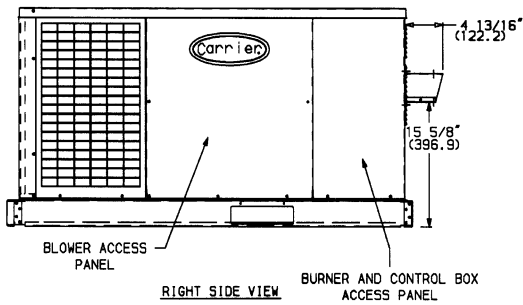

**REQ'D CLEARANCES FOR SERVICING. in. (mm)**

Duct panel	0
Unit top	36 (914)
Side opposite ducts	36 (914)
Compressor access (Except for NEC requirements)	36 (914)

**REQ'D CLEARANCES TO COMBUSTIBLE MAT'L. in. (mm)**

Maximum extension of overhangs	48 (1219)
Unit top	14 (356)
Duct side of unit	2 (51)
Side opposite ducts	14 (356)
Bottom of unit	0
Flue panel	36 (914)

**NEC REQ'D CLEARANCES. in. (mm)**

Between units, control box side	42 (1067)
Unit and ungrounded surfaces, control box side	36 (914)
Unit and block or concrete walls and other grounded surfaces, control box side	42 (1067)

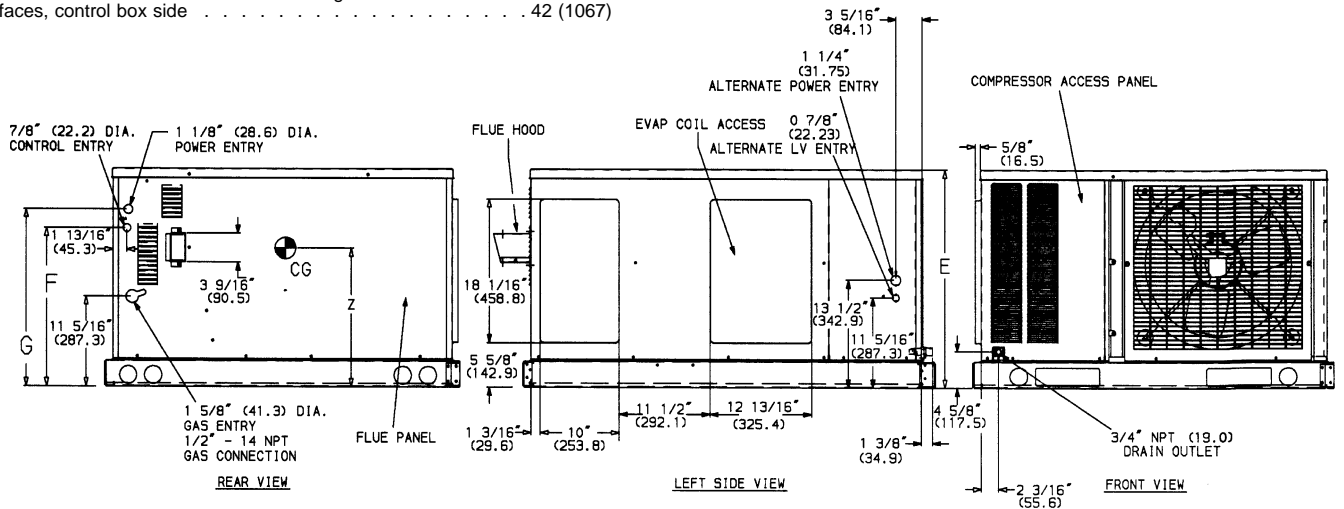

UNIT	ELECTRICAL CHARACTERISTICS	UNIT WEIGHT		CORNER WEIGHT (lb/kg)				UNIT HEIGHT (in./mm)
		lb	kg	A	B	C	D	E
48SS018040	208/230-1-60	296	135	87/40	68/31	82/37	59/27	27.4/697
48SS024040	208/230-1-60	327	149	103/47	49/22	129/59	46/21	27.4/697
48SS024060	208/230-1-60	339	155	106/48	52/24	132/60	49/22	27.4/697
48SS030040	208/230-1-60, 208/230-3-60	344	157	106/48	53/24	132/60	53/24	27.4/697
48SS030060/080	208/230-1-60, 208/230-3-60	356	162	102/46	71/32	123/56	60/27	27.4/697
48SS036060/080	208/230-1-60, 208/230-3-60, 460-3-60	360	164	92/42	82/37	117/53	69/31	27.4/697
48SS036100/120	208/230-1-60, 208/230-3-60, 460-3-60	372	169	95/43	85/39	120/55	72/33	27.4/697
48SS042060/080	208/230-1-60, 208/230-3-60, 460-3-60	399	181	101/46	92/42	125/57	81/37	31.4/798
48SS042100/120	208/230-1-60, 208/230-3-60, 460-3-60	411	187	104/47	95/43	128/58	84/38	31.4/798

UNIT	F in./mm	G in./mm	CENTER OF GRAVITY in./mm		
			X	Y	Z
48SS018040	19 7/8/504.8	22 1/4/565.4	25.04/636	22.72/577	13.16/334.3
48SS024040			26.90/683.3	20.17/512.3	
48SS024060			26.82/681.2	20.22/513.6	
48SS030040			26.57/674.9	20.1 /509.3	
48SS030060/080			26.93/684	21.1 /535.4	
48SS036060/080			27.31/693.7	21.0 /532.6	
48SS036100/120			27.23/691.6	21.0 /533.1	
48SS042060/080	23 7/8/606.4	26 1/4/666.8	26.87/682.5	21.0 /533.1	14.96/380
48SS042100/120			26.81/681	21.0 /533.7	

**LEGEND**

CG	— Center of Gravity	MAT'L	— Material
COND	— Condenser	NEC	— National Electrical Code
LV	— Low Voltage	REQ'D	— Required

**NOTES:**

- Clearances must be maintained to prevent recirculation of air from outdoor-fan discharge.
- Adequate clearance around air openings into combustion chamber must be provided.

**Fig. 3 — 48SS018-042 With Optional Base Rail, Unit Dimensions**

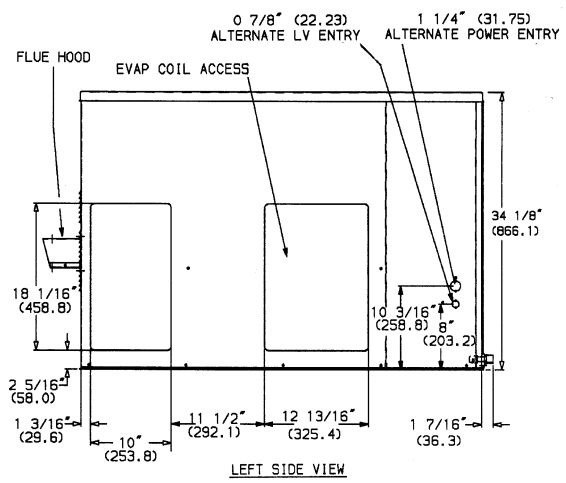
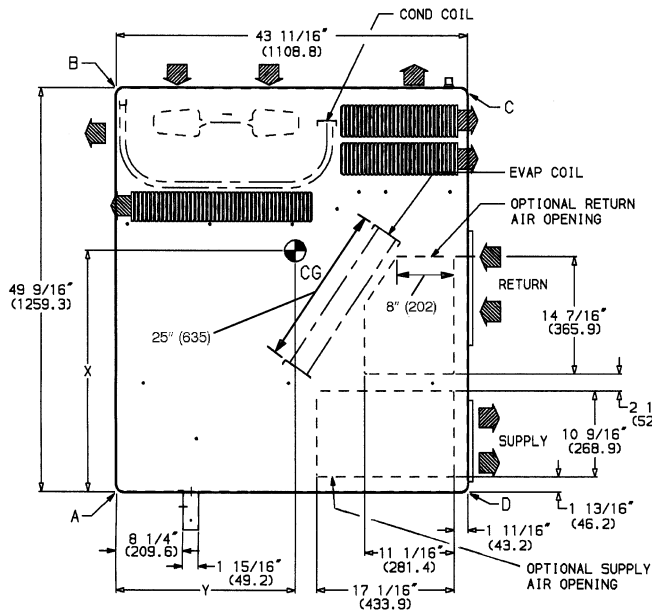

**REQ'D CLEARANCES FOR SERVICING. in. (mm)**

Duct panel	0
Unit top	36 (914)
Side opposite ducts	36 (914)
Compressor access (Except for NEC requirements)	36 (914)

**REQ'D CLEARANCES TO COMBUSTIBLE MAT'L. in. (mm)**

Maximum extension of overhangs	48 (1219)
Unit top	14 (356)
Duct side of unit	2 (51)
Side opposite ducts	14 (356)
Bottom of unit	0
Flue panel	36 (914)

**NEC REQ'D CLEARANCES. in. (mm)**

Between units, control box side	42 (1067)
Unit and ungrounded surfaces, control box side	36 (914)
Unit and block or concrete walls and other grounded surfaces, control box side	42 (1067)

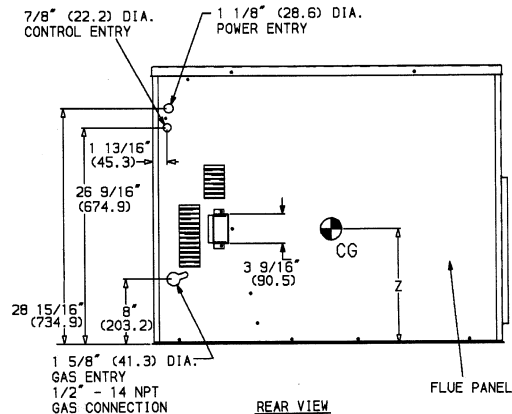
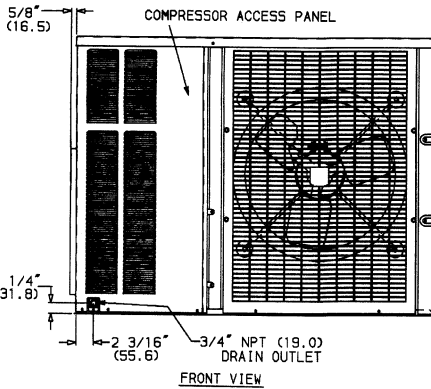
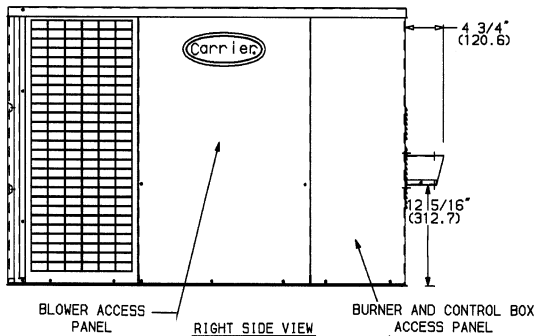

UNIT	ELECTRICAL CHARACTERISTICS	UNIT WEIGHT		CORNER WEIGHT (lb/kg)			
		lb	kg	A	B	C	D
48SS048080	208/230-1-60, 208/230-3-60, 460-3-60	414	188	107/49	83/38	158/72	66/30
48SS048100/120/140	208/230-1-60, 208/230-3-60, 460-3-60	426	193	110/50	86/39	159/72	71/32
48SS060080	208/230-1-60, 208/230-3-60, 460-3-60	453	206	117/53	93/42	167/76	76/35
48SS060100/120/140	208/230-1-60, 208/230-3-60, 460-3-60	465	211	120/55	96/44	167/76	82/37

UNIT	CENTER OF GRAVITY (in./mm)		
	X	Y	Z
48SS048080	28.76/731	23.46/596	15.35/390
48SS048100/120/140	28.42/722	23.42/595	15.35/390
48SS060080	28.36/720	23.27/591	15.35/390
48SS060100/120/140	27.95/710	23.23/590	15.35/390

**LEGEND**

CG	— Center of Gravity	MAT'L	— Material
COND	— Condenser	NEC	— National Electrical Code
LV	— Low Voltage	REQ'D	— Required

**NOTES:**

- Clearances must be maintained to prevent recirculation of air from outdoor-fan discharge.
- Adequate clearance around air openings into combustion chamber must be provided.

**Fig. 4 — 48SS048,060 Without Base Rail, Unit Dimensions**

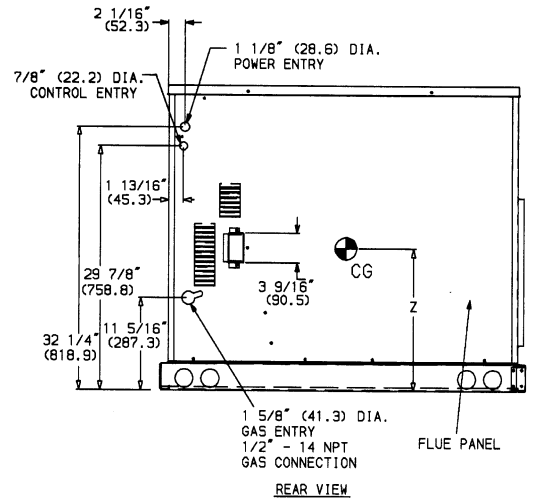
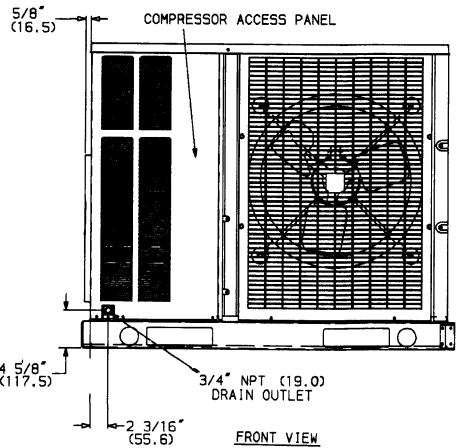
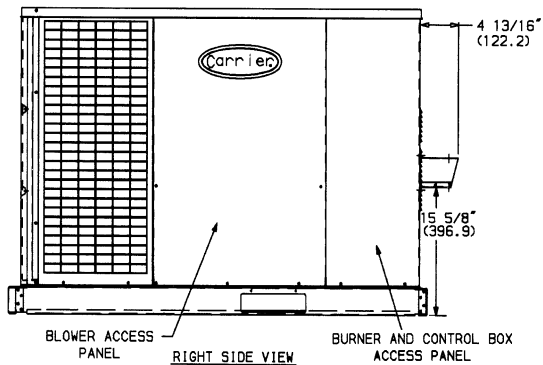
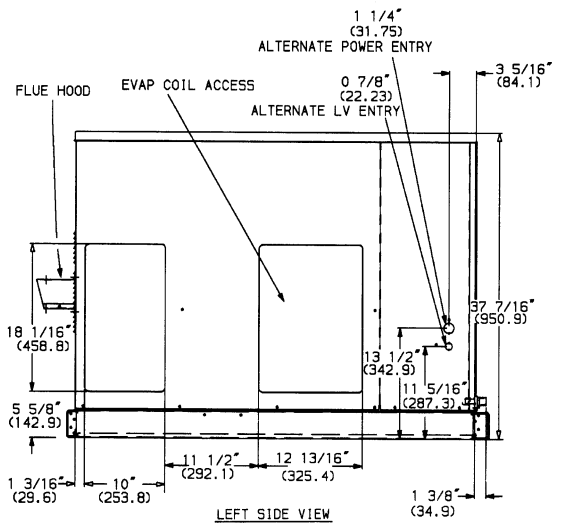
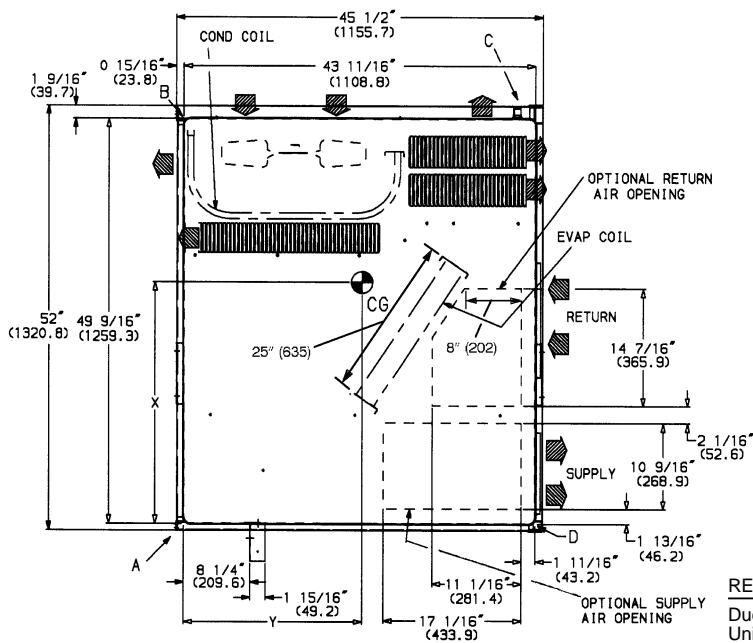

**REQ'D CLEARANCES FOR SERVICING. in. (mm)**

Duct panel	0
Unit top	36 (914)
Side opposite ducts	36 (914)
Compressor access (Except for NEC requirements)	36 (914)

**REQ'D CLEARANCES TO COMBUSTIBLE MAT'L. in. (mm)**

Maximum extension of overhangs	48 (1219)
Unit top	14 (356)
Duct side of unit	2 (51)
Side opposite ducts	14 (356)
Bottom of unit	0
Flue panel	36 (914)

**NEC REQ'D CLEARANCES. in. (mm)**

Between units, control box side	42 (1067)
Unit and ungrounded surfaces, control box side	36 (914)
Unit and block or concrete walls and other grounded surfaces, control box side	42 (1067)

UNIT	ELECTRICAL CHARACTERISTICS	UNIT WEIGHT		CORNER WEIGHT (lb/kg)			
		lb	kg	A	B	C	D
48SS048080	208/230-1-60, 208/230-3-60, 460-3-60	438	199	113/51	89/40	164/75	72/33
48SS048100/120/140	208/230-1-60, 208/230-3-60, 460-3-60	450	205	116/53	92/42	165/75	77/35
48SS060080	208/230-1-60, 208/230-3-60, 460-3-60	477	217	123/56	99/45	173/79	82/37
48SS060100/120/140	208/230-1-60, 208/230-3-60, 460-3-60	489	222	126/57	102/46	173/79	88/40

UNIT	CENTER OF GRAVITY (in./mm)		
	X	Y	Z
48SS048080	28.54/724.9	20.00/508	17.66/448.6
48SS048100/120/140	28.22/716.8	20.05/509.3	17.66/448.6
48SS060080	28.18/715.6	20.19/512.8	17.66/448.6
48SS060100/120/140	27.79/705.9	20.23/513.8	17.66/448.6

**LEGEND**

- CG — Center of Gravity
- COND — Condenser
- LV — Low Voltage
- MAT'L — Material
- NEC — National Electrical Code
- REQ'D — Required

**NOTES:**

1. Clearances must be maintained to prevent recirculation of air from outdoor-fan discharge.
2. Adequate clearance around air openings into combustion chamber must be provided.

**Fig. 5 — 48SS048,060 With Optional Base Rail, Unit Dimensions**

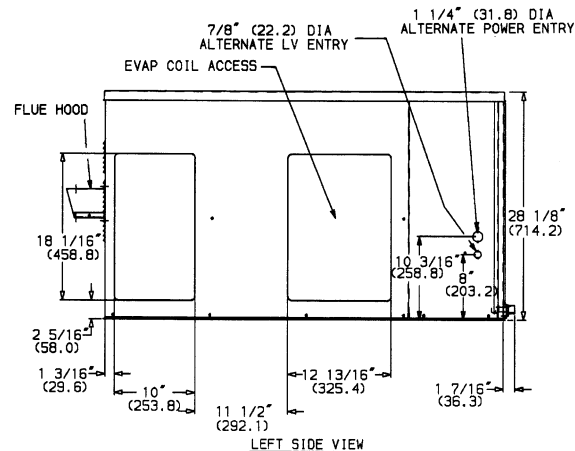
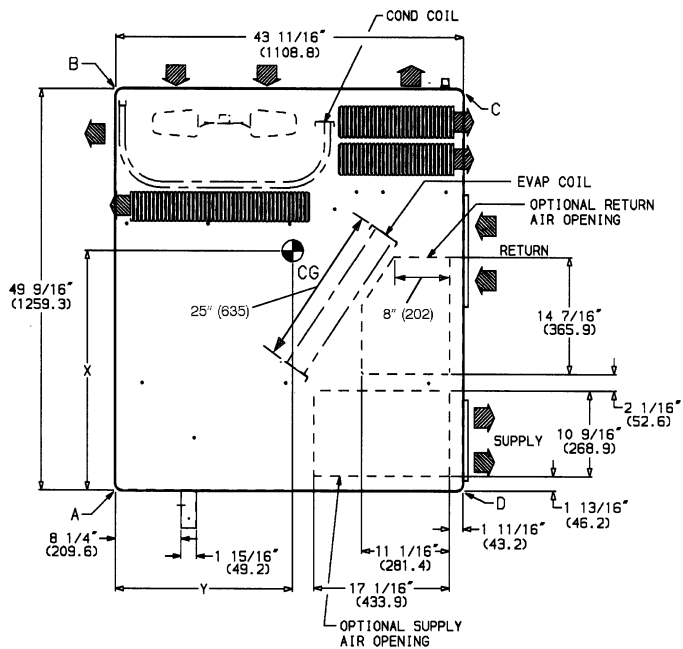

**REQ'D CLEARANCES FOR SERVICING. in. (mm)**

Duct panel	0
Unit top	.36 (914)
Side opposite ducts	.36 (914)
Compressor access	.36 (914)
(Except for NEC requirements)	

**REQ'D CLEARANCES TO COMBUSTIBLE MAT'L. in. (mm)**

Maximum extension of overhangs	.48 (1219)
Unit top	.14 (356)
Duct side of unit	.2 (51)
Side opposite ducts	.14 (356)
Bottom of unit	.0
Flue panel	.36 (914)

**NEC REQ'D CLEARANCES. in. (mm)**

Between units, control box side	.42 (1067)
Unit and ungrounded surfaces, control box side	.36 (914)
Unit and block or concrete walls and other grounded surfaces, control box side	.42 (1067)

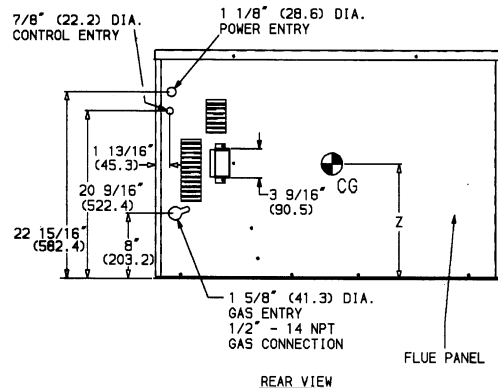
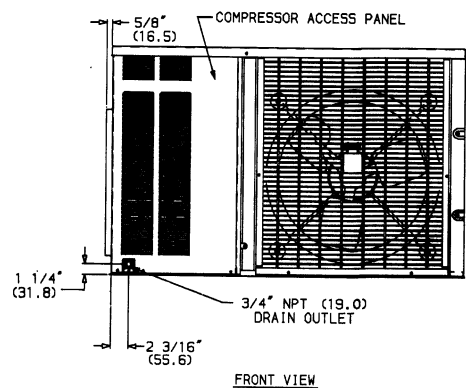
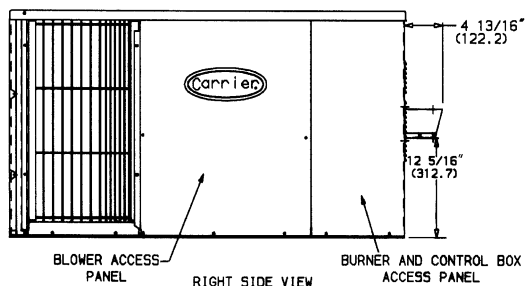

UNIT	ELECTRICAL CHARACTERISTICS	UNIT WEIGHT		CORNER WEIGHT (lb/kg)			
		lb	kg	A	B	C	D
48SX024040	208/230-1-60	333	151	104/47	50/23	130/59	49/22
48SX024060	208/230-1-60	345	157	107/49	53/24	133/60	52/24
48SX030040	208/230-1-60	336	153	97/44	66/30	118/54	55/25
48SX030060/080	208/230-1-60	348	158	100/45	69/31	121/55	58/26
48SX036060/080	208/230-1-60, 208/230-3-60, 460-3-60	366	166	94/43	84/38	117/53	71/32
48SX036100/120	208/230-1-60, 208/230-3-60, 460-3-60	378	172	97/44	87/40	120/55	74/34

UNIT	CENTER OF GRAVITY (in./mm)		
	X	Y	Z
48SX024040	26.71/678	20.06/510	12.65/321
48SX024060	26.64/677	20.12/511	12.65/321
48SX030040	27.06/687	21.05/535	12.65/321
48SX030060/080	26.98/685	21.07/535	12.65/321
48SX036060/080	27.14/689	21.10/536	12.65/321
48SX036100/120	27.06/687	21.12/536	12.65/321

**LEGEND**

CG	— Center of Gravity	MAT'L	— Material
COND	— Condenser	NEC	— National Electrical Code
LV	— Low Voltage	REQ'D	— Required

**NOTES:**

- Clearances must be maintained to prevent recirculation of air from outdoor-fan discharge.
- Adequate clearance around air openings into combustion chamber must be provided.

**Fig. 6 — 48SX024-036 Without Base Rail, Unit Dimensions**

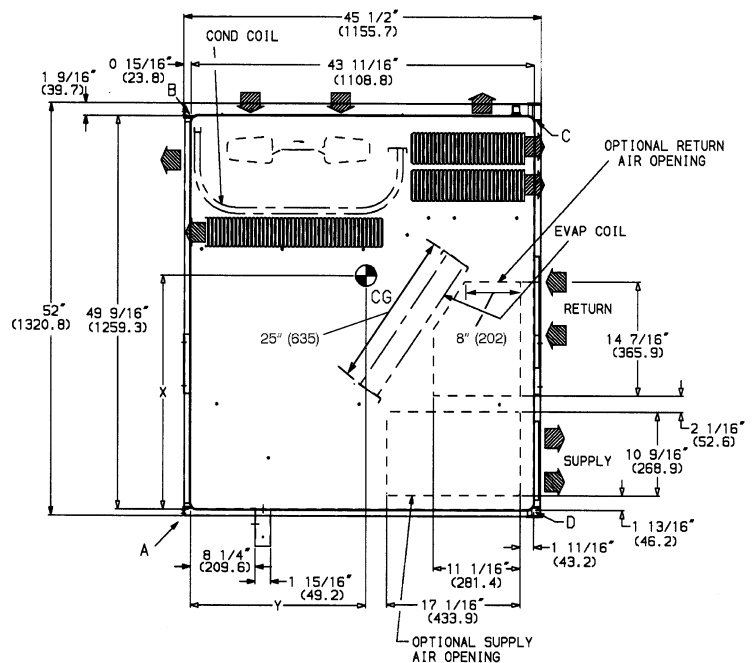
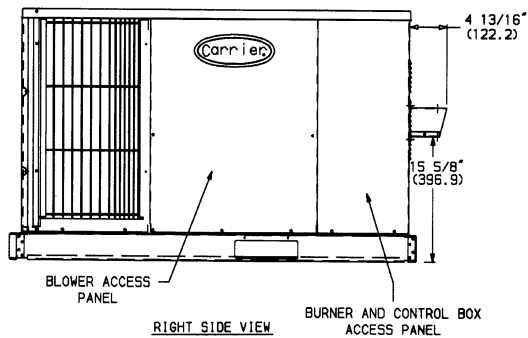

**REQ'D CLEARANCES FOR SERVICING. in. (mm)**

Duct panel	0
Unit top	36 (914)
Side opposite ducts	36 (914)
Compressor access (Except for NEC requirements)	36 (914)

**REQ'D CLEARANCES TO COMBUSTIBLE MAT'L. in. (mm)**

Maximum extension of overhangs	48 (1219)
Unit top	14 (356)
Duct side of unit	2 (51)
Side opposite ducts	14 (356)
Bottom of unit	0
Flue panel	36 (914)

**NEC REQ'D CLEARANCES. in. (mm)**

Between units, control box side	42 (1067)
Unit and ungrounded surfaces, control box side	36 (914)
Unit and block or concrete walls and other grounded surfaces, control box side	42 (1067)

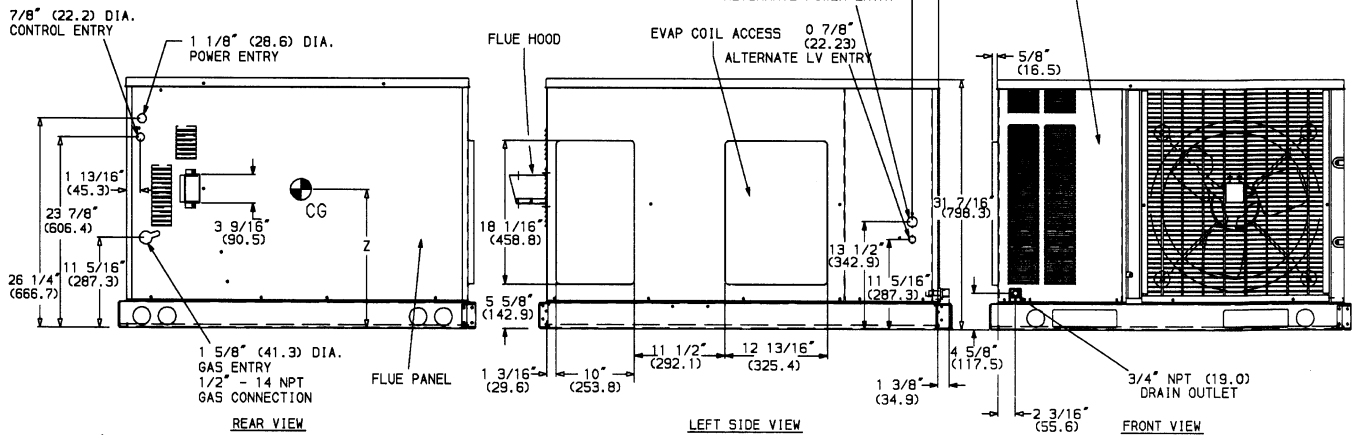

UNIT	ELECTRICAL CHARACTERISTICS	UNIT WEIGHT		CORNER WEIGHT (lb/kg)			
		lb	kg	A	B	C	D
48SX024040	208/230-1-60	357	163	110/50	56/25	136/62	55/25
48SX024060	208/230-1-60	369	168	113/51	59/27	139/63	58/26
48SX030040	208/230-1-60	360	164	103/47	72/33	124/56	61/28
48SX030060/080	208/230-1-60	372	169	106/48	75/34	127/58	64/29
48SX036060/080	208/230-1-60, 208/230-3-60, 460-3-60	390	177	100/45	90/41	123/56	77/35
48SX036100/120	208/230-1-60, 208/230-3-60, 460-3-60	402	183	103/47	93/42	127/57	80/36

UNIT	CENTER OF GRAVITY (in./mm)		
	X	Y	Z
48SX024040	26.57/674.9	20.17/512.3	14.96/380.0
48SX024060	26.51/673.3	20.22/513.6	14.96/380.0
48SX030040	26.90/683.3	21.09/535.7	14.96/380.0
48SX030060/080	26.83/681.5	21.11/536.2	14.96/380.0
48SX036060/080	26.99/685.5	21.14/537.0	14.96/380.0
48SX036100/120	26.92/683.8	21.14/537.0	14.96/380.0

**LEGEND**

CG	— Center of Gravity	MAT'L	— Material
COND	— Condenser	NEC	— National Electrical Code
LV	— Low Voltage	REQ'D	— Required

**NOTES:**

- Clearances must be maintained to prevent recirculation of air from outdoor fan discharge.
- Adequate clearance around air openings into combustion chamber must be provided.

**Fig. 7 — 48SX024-036 With Optional Base Rail, Unit Dimensions**

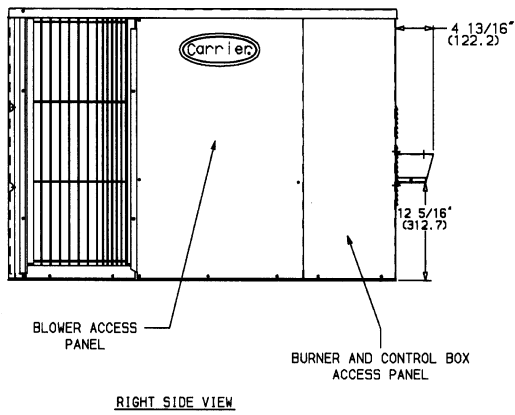

**REQ'D CLEARANCES FOR SERVICING. in. (mm)**

Duct panel	0
Unit top	36 (914)
Side opposite ducts	36 (914)
Compressor access (Except for NEC requirements)	36 (914)

**REQ'D CLEARANCES TO COMBUSTIBLE MAT'L. in. (mm)**

Maximum extension of overhangs	48 (1219)
Unit top	14 (356)
Duct side of unit	2 (51)
Side opposite ducts	14 (356)
Bottom of unit	0
Flue panel	36 (914)

**NEC REQ'D CLEARANCES. in. (mm)**

Between units, control box side	42 (1067)
Unit and ungrounded surfaces, control box side	36 (914)
Unit and block or concrete walls and other grounded surfaces, control box side	42 (1067)

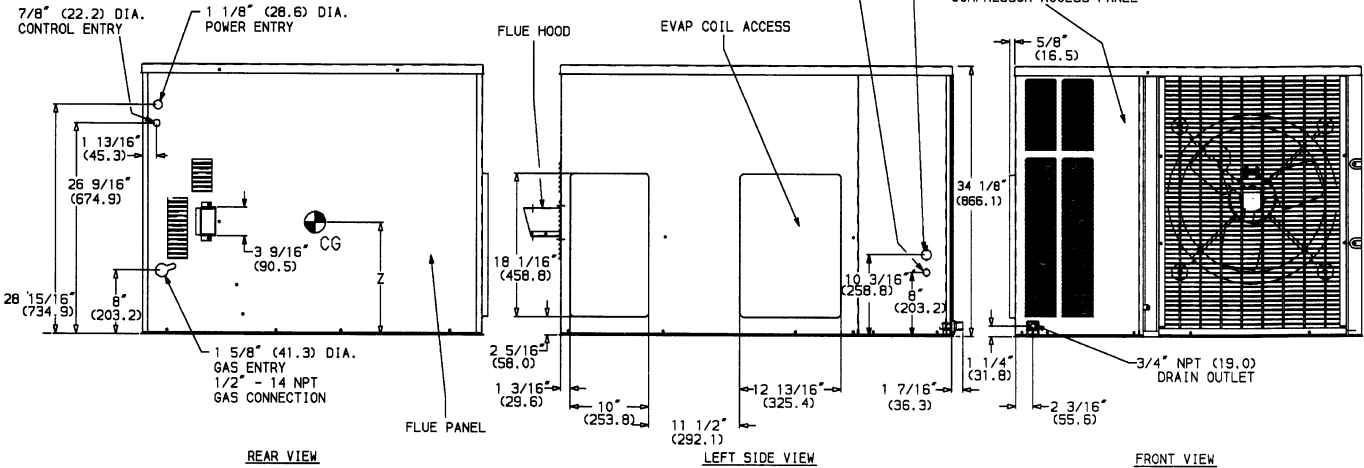
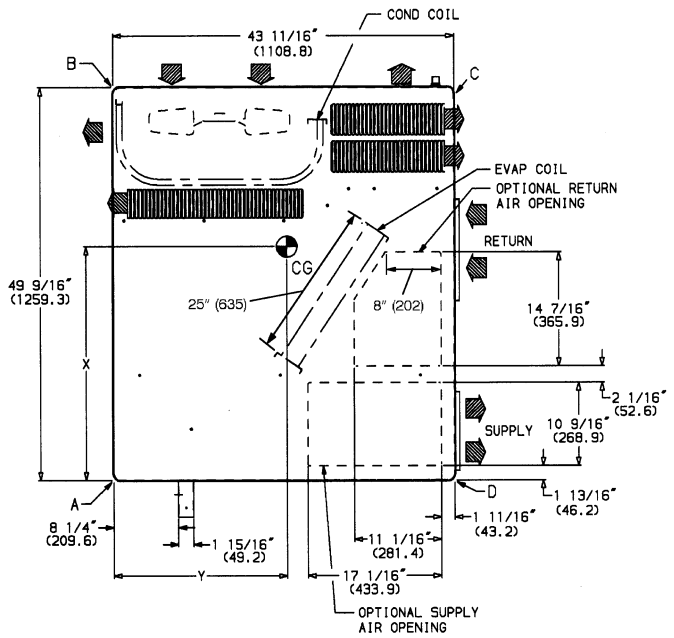

UNIT	ELECTRICAL CHARACTERISTICS	UNIT WEIGHT		CORNER WEIGHT (lb/kg)			
		lb	kg	A	B	C	D
48SX042060/080	208/230-1-60, 208/230-3-60, 460-3-60	391	178	100/45	91/41	120/55	80/36
48SX042100/120	208/230-1-60, 208/230-3-60, 460-3-60	403	183	103/47	94/43	123/56	83/38
48SX048080	208/230-1-60, 208/230-3-60, 460-3-60	422	192	109/50	85/39	158/72	70/32
48SX048100/120/140	208/230-1-60, 208/230-3-60, 460-3-60	434	197	112/51	88/40	161/73	73/33
48SX060080	208/230-1-60, 208/230-3-60	453	206	117/53	93/42	167/76	76/35
48SX060100/120/140	208/230-1-60, 208/230-3-60	465	211	120/55	96/44	167/76	82/37

UNIT	CENTER OF GRAVITY (in./mm)		
	X	Y	Z
48SX042060/080	26.66/677	21.19/538	15.35/390
48SX042100/120	26.61/676	21.21/539	15.35/390
48SX048080	28.45/723	19.95/507	15.35/390
48SX048100/120/140	28.35/720	19.99/508	15.35/390
48SX060080	28.36/720	23.27/591	15.35/390
48SX060100/120/140	27.95/710	23.23/590	15.35/390

**LEGEND**  
**CG** — Center of Gravity    **MAT'L** — Material  
**COND** — Condenser        **NEC** — National Electrical Code  
**LV** — Low Voltage         **REQ'D** — Required

**NOTES:**  
1. Clearances must be maintained to prevent recirculation of air from outdoor fan discharge.  
2. Adequate clearance around air openings into combustion chamber must be provided.

**Fig. 8 — 48SX042-060 Without Base Rail, Unit Dimensions**



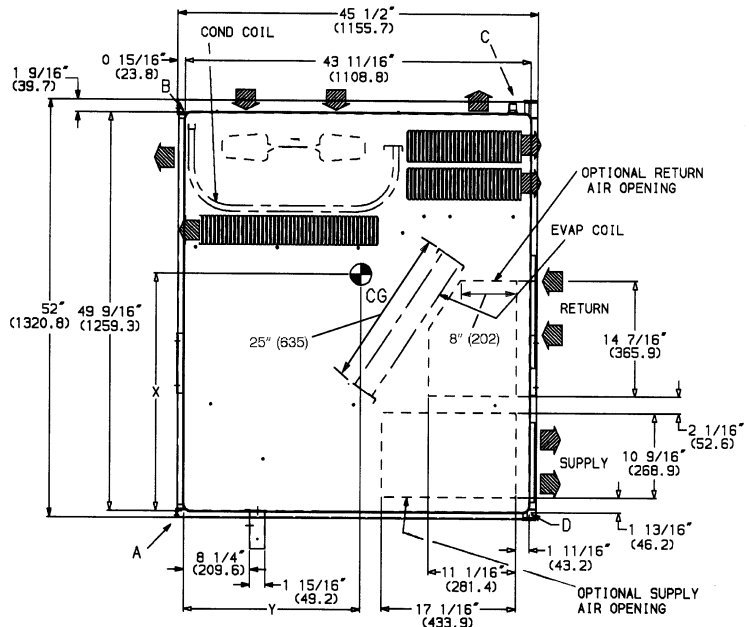
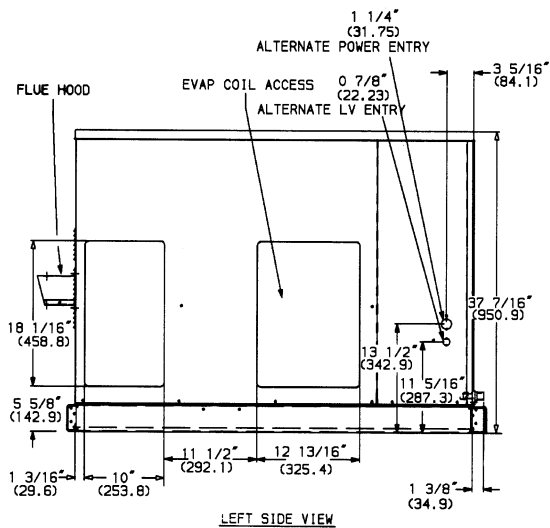
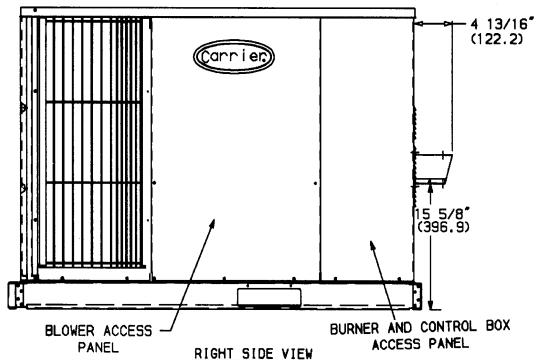
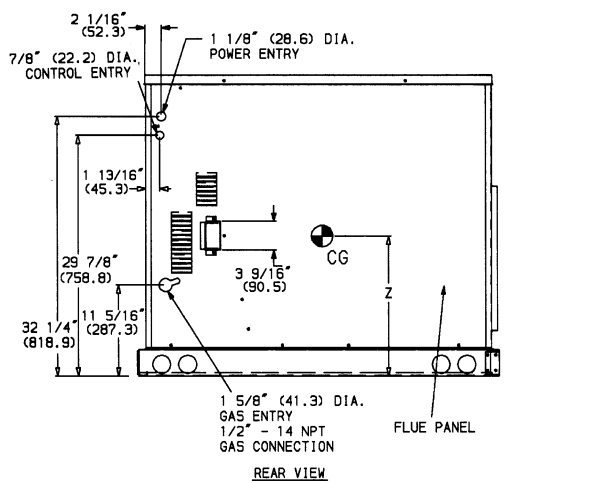

**REQ'D CLEARANCES FOR SERVICING. in. (mm)**

Duct panel	0
Unit top	36 (914)
Side opposite ducts	36 (914)
Compressor access	36 (914)
(Except for NEC requirements)	

**REQ'D CLEARANCES TO COMBUSTIBLE MAT'L. in. (mm)**

Maximum extension of overhangs	48 (1219)
Unit top	14 (356)
Duct side of unit	2 (51)
Side opposite ducts	14 (356)
Bottom of unit	0
Flue panel	36 (914)

**LEGEND**  
 CG — Center of Gravity  
 COND — Condenser  
 LV — Low Voltage  
 MAT'L — Material  
 NEC — National Electrical Code  
 REQ'D — Required

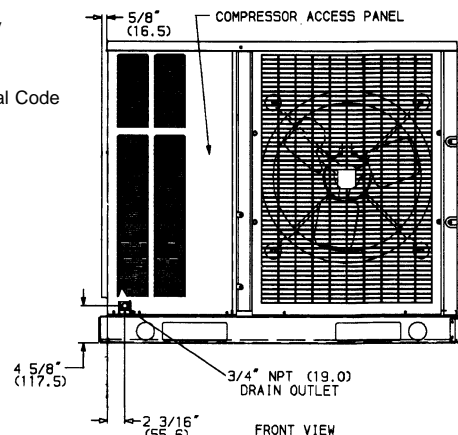

UNIT	ELECTRICAL CHARACTERISTICS	UNIT WEIGHT		CORNER WEIGHT (lb/kg)			
		lb	kg	A	B	C	D
48SX042060,080	208/230-1-60, 208/230-3-60, 460-3-60	415	189	106/48	97/44	126/57	86/39
48SX042100,120	208/230-1-60, 208/230-3-60, 460-3-60	427	194	109/50	100/45	129/59	89/40
48SX048080	208/230-1-60, 208/230-3-60, 460-3-60	446	203	115/52	91/41	164/75	76/35
48SX048100/120/140	208/230-1-60, 208/230-3-60, 460-3-60	458	208	118/54	94/43	167/76	79/36
48SX060080	208/230-1-60, 208/230-3-60	477	217	123/56	99/45	173/79	82/37
48SX060100/120/140	208/230-1-60, 208/230-3-60	489	222	126/57	102/46	173/79	88/40

UNIT	CENTER OF GRAVITY (in./mm)		
	X	Y	Z
48SX042060,080	26.55/674.4	21.22/539.0	17.66/448.6
48SX042100,120	26.50/673.0	21.24/539.6	17.66/448.6
48SX048080	28.25/717.6	20.04/509.0	17.66/448.6
48SX048100/120/140	28.16/715.3	20.08/510.0	17.66/448.6
48SX060080	28.18/715.6	20.19/512.8	17.66/448.6
48SX060100/120/140	27.79/705.9	20.23/513.8	17.66/448.6

**NOTES:**

- Clearances must be maintained to prevent recirculation of air from outdoor-fan discharge.
- Adequate clearance around air openings into combustion chamber must be provided.

**NEC REQ'D CLEARANCES. in. (mm)**

Between units, control box side	42 (1067)
Unit and ungrounded surfaces, control box side	36 (914)
Unit and block or concrete walls and other grounded surfaces, control box side	42 (1067)

**Fig. 9 — 48SX042-060 With Optional Base Rail, Unit Dimensions**

## RECEIVING AND INSTALLATION

### Step 1 — Check Equipment

**IDENTIFY UNIT** — The unit model number and serial number are stamped on unit identification plate. Check this information against shipping papers and job data.

**INSPECT SHIPMENT** — Inspect for shipping damage while unit is still on shipping pallet. If unit appears to be damaged or is torn loose from its anchorage, have it examined by transportation inspectors before removal. Forward claim papers directly to transportation company. Manufacturer is not responsible for any damage incurred in transit.

Check all items against shipping list. Immediately notify the nearest Carrier Air Conditioning office if any item is missing.

To prevent loss or damage, leave all parts in original packages until installation.

### Step 2 — Provide Unit Support

**ROOF CURB** — Install accessory roof curb in accordance with instructions shipped with curb. See Fig. 10 for roof curb dimensions. Install insulation, cant strips, roofing, and flashing. Ductwork must be attached to curb.

**IMPORTANT:** The gasketing of the unit to the roof curb is critical for a watertight seal. Install gasketing material supplied with the roof curb. Improperly applied gasketing can also result in air leaks and poor unit performance.

Curb should be level to within ¼ inch. This is necessary for unit drain to function properly. Refer to accessory roof curb installation instructions for additional information as required.

**SLAB MOUNT** — Place the unit on a solid, level concrete pad that is a minimum of 4 in. thick with 2 in. above grade. The slab should be flush on the front of the unit (to allow condensate drain installation) and should extend 2 in. on the three remaining sides of the unit. See Fig. 11. Install a 6-in. gravel apron in front of condenser-air inlets to prevent obstruction of airflow by grass or shrubs. Do not secure the unit to the slab *except* when required by local codes.

**FLUSH MOUNT** — Place side of unit with duct panel flush against transition. On units with optional base rails, the skirt on duct-panel side of unit can be removed to allow unit to be mounted flush against transitions that extend below basepan of unit. To remove skirt, remove 4 screws holding skirt to base rail. Then, remove skirt.

To remove wood support under unit (with base rail only), loosen 4 screws above rigging holes and slide assembly out through rectangular hole.

**Step 3 — Field Fabricate Ductwork** — Secure all ducts to roof curb and building structure on vertical discharge units. *Do not connect ductwork to unit.* For horizontal applications, unit is provided with flanges on the horizontal openings. All ductwork should be secured to the flanges. Insulate and weatherproof all external ductwork, joints, and roof openings with counter flashing and mastic in accordance with applicable codes.

Ducts passing through an unconditioned space must be insulated and covered with a vapor barrier.

If a plenum return is used on a vertical unit, the return should be ducted through the roof deck to comply with applicable fire codes.

A minimum clearance is not required around ductwork. Cabinet return-air static shall not exceed –.25 in. wg.

**Step 4 — Provide Clearances** — The required minimum operating and service clearances are shown in Fig. 2-9. Adequate combustion, ventilation, and condenser air must be provided, in accordance with section 5.3, Air for Combustion and Ventilation, of the National Fuel Gas Code ANSI (American National Standards Institute) Z223.1 (in Canada, sections 7.2, 7.3 or 7.4 or Can/CGA [Canadian Gas Association] B149 Installation Codes), or applicable provisions of local building code.

#### ⚠ CAUTION

Do not restrict condenser airflow. An air restriction at either the outdoor-air inlet or the fan discharge can be detrimental to compressor life.

The condenser fan pushes air through the condenser coil and discharges it through the bank of louvers in the top cover, the decorative grille on the right side of the unit, and the compressor access panel. Be sure that the fan discharge does not recirculate to the condenser coil. Do not locate the unit in either a corner or under an overhead obstruction. The minimum clearance under a partial overhang (such as a normal house overhang) is 48-in. above the unit top. The maximum horizontal extension of a partial overhang must not exceed 48 inches.

Do not place the unit where water, ice, or snow from an overhang or roof will damage or flood the unit. Do not install the unit on carpeting, tile, or other combustible materials. The unit may be installed on wood flooring or on Class A, B, or C roof covering materials.

### Step 5 — Rig and Place Unit

#### ⚠ CAUTION

When installing the unit on a rooftop, be sure the roof will support the additional weight. Refer to Fig. 2-9 for corner weight information.

Use spreader bars or crate top when rigging the unit. The units must be rigged for lifting as shown in Fig. 12 and 13. Refer to Tables 1 and 2 for operating weight and to Fig. 2-9 for corner weights. *Use extreme caution to prevent damage when moving the unit. Unit must remain in an upright position during all rigging and moving operations.* The unit must be level for proper condensate drainage; therefore, the ground-level pad or accessory roof curb must be level before setting the unit in place. When a field-fabricated support is used, be sure that the support is level and properly supports the unit.

	PART NUMBER	"A"
FLAT CURB	CPRFCURB001A00	8" [203]
	CPRFCURB002A00	11" [279]
	CPRFCURB003A00	14" [356]

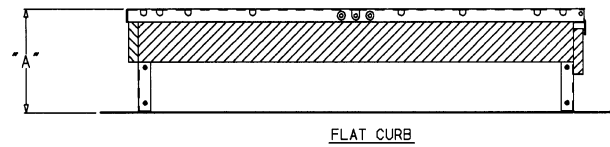

**NOTES:**

1. Roof curb must be set up for unit being installed.
2. Seal strip must be applied as required for unit being installed.
3. Dimensions in [ ] are in millimeters.
4. Roof curb is made of 16 gage steel.
5. Attach ductwork to curb (flanges of duct rest on curb).
6. Service clearance 4 ft on each side.
7. Direction of airflow.
8. Insulated panels: 1-in. thick fiberglass 1 lb density.

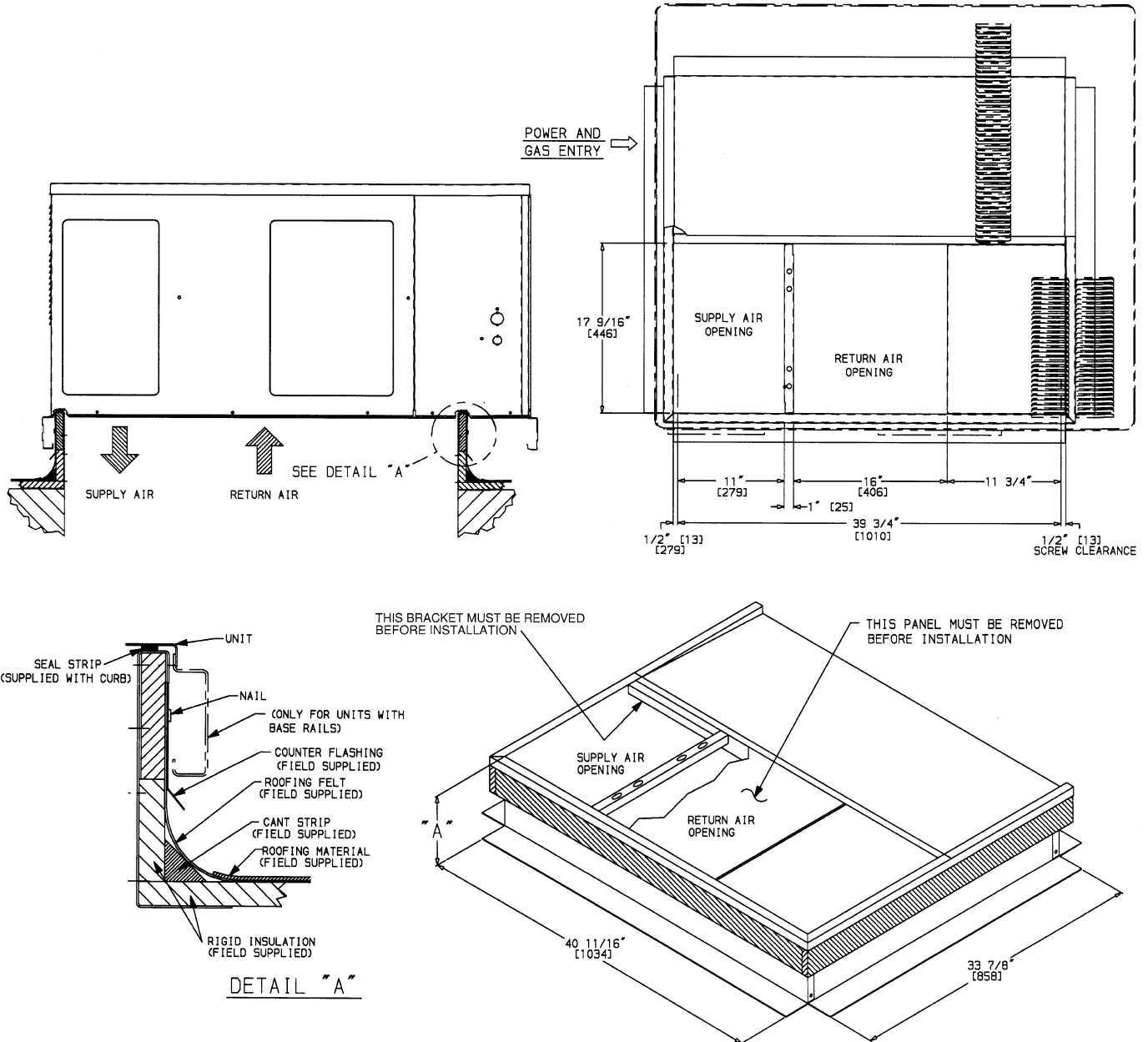

**Fig. 10 — Roof Curb Dimensions**

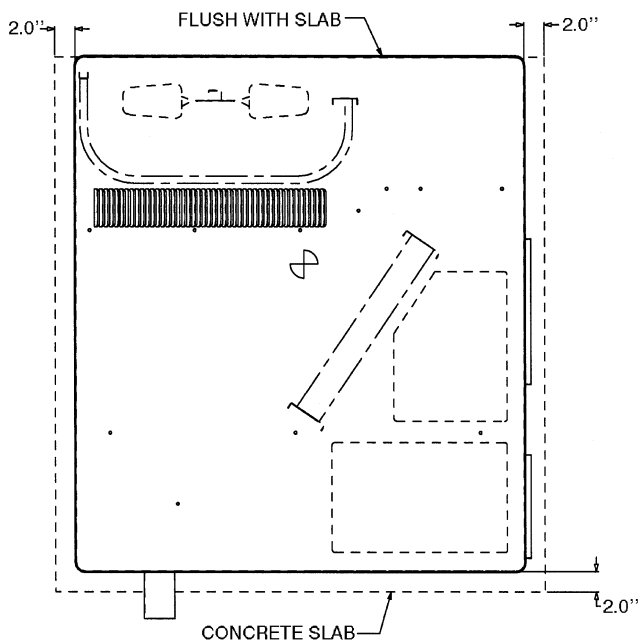

**Fig. 11 — Slab Mounting Details**

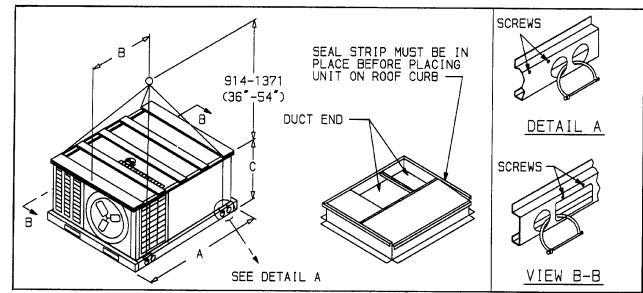
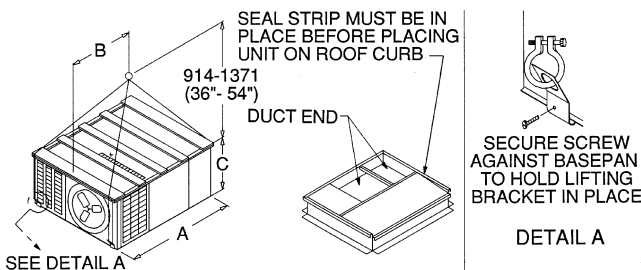

**NOTICE TO RIGGERS**

Hook rigging shackles through holes in lifting brackets, as shown in Detail "A." Lifting brackets to be centered around the unit center of gravity. Use wooden top skid when rigging, to prevent rigging straps from damaging unit.

**CAUTION**

All panels must be in place when rigging.

UNIT 48SS	MAX WEIGHT		A		B		C		
	Size	lb	kg	in.	mm	in.	mm	in.	mm
018	332	150	49.4	1255	24.3	618	24.85	631	
024	375	170			22.4	570	24.85	631	
030	384	174			22.3	565	24.85	631	
036	408	185			22.0	559	24.85	631	
042	447	203			22.5	571	28.85	733	
048	486	220			21.0	533	34.85	885	
060	525	238	21.5	545	34.85	885			
<b>UNIT 48SX</b>									
024	405	184	49.4	1255	22.8	579	28.9	733	
030	408	185			22.4	569	28.9	733	
036	438	199			22.4	569	28.9	733	
042	463	210			22.8	579	34.9	885	
048	494	224			21.1	536	34.9	885	
060	525	238			21.5	545	34.9	885	

**Fig. 12 — Suggested Rigging for Units Without Base Rail**

**NOTICE TO RIGGERS**

Hook rigging shackles through holes in lifting brackets, as shown in Detail "A." Lifting brackets to be centered around the unit center of gravity. Use wood top skid when rigging, to prevent rigging straps from damaging unit. Remove 4 screws to slide wood support through rectangular hole in rail.

**CAUTION**

All panels must be in place when rigging.

UNIT 48SS	MAX WEIGHT		A		B		C		
	Size	lb	kg	in.	mm	in.	mm	in.	mm
018	320	145	49.4	1255	24.4	619	28.2	715	
024	363	165			22.6	574	28.2	715	
030	380	172			22.5	571	28.2	715	
036	396	180			22.2	563	28.2	715	
042	435	197			22.6	574	32.2	816	
048	474	215			21.2	538	38.2	969	
060	513	233	21.6	549	38.2	969			
<b>UNIT 48SX</b>									
024	393	178	49.4	1255	22.9	582	32.2	816	
030	396	180			22.6	574	32.2	816	
036	426	193			22.5	571	32.2	816	
042	451	205			22.9	582	38.2	969	
048	482	219			21.3	540	38.2	969	
060	513	233			21.6	549	38.2	969	

**Fig. 13 — Suggested Rigging for Units With Optional Base Rail**

**UNITS WITHOUT BASE RAIL** — If accessory rigging brackets are to be used for rigging, install them as follows:

**WARNING**

Secure screws and paint protectors solidly against unit basepan to hold lifting brackets in position.

Never use lifting brackets when the temperature is below -10 F.

Never exceed 200 lbs per bracket of lifting force.

Never use lifting brackets for lifting other models of air-conditioning units.

Lifting point should be directly over the unit center of gravity.

1. Position brackets as close to the corners of unit as possible. Be sure brackets are well outside of center of gravity. (See Fig. 2, 4, 6, 8, and 12.)
2. Position paint protectors and foam strips between screws and painted surface of unit. Tighten screws until they make contact with the paint protectors.
3. Secure device or hook of sufficient strength to hole in bracket as shown in detail "A" of Fig. 12.
4. If wood top is available, use it for a spreader bar to prevent straps from damaging unit. If wood top is not available, use spreader bars of sufficient length.

UNITS WITH OPTIONAL BASE RAIL — Lifting holes are provided in optional base rail as shown in Fig. 13. Operating weights are shown in Tables 1 and 2. Refer to rigging instructions on unit.

Protective wood support must be removed from unit before unit is mounted to curb. Remove 4 screws that secure support above rigging holes in rails. Slide support out through rectangular hole in rail. See Fig. 13.

### Step 6 — Connect Condensate Drain

NOTE: When installing condensate drain connection be sure to comply with local codes and restrictions.

Model 48SS,SX disposes of condensate water through a 3/4 in. NPT fitting which exits through the compressor access panel. See Fig. 2-9 for location.

Condensate water can be drained directly onto the roof in rooftop installations (where permitted) or onto a gravel apron in ground-level installations. Install a field-supplied condensate trap at end of condensate connection to ensure proper drainage. Make sure that the outlet of the trap is at least 1 in. lower than the drain-pan condensate connection to prevent the pan from overflowing. See Fig. 14. Prime the trap with water. When using a gravel apron, make sure it slopes away from the unit.

If the installation requires draining the condensate water away from the unit, install a 2-in. trap at the condensate connection to ensure proper drainage. See Fig. 14. Make sure that the outlet of the trap is at least 1 in. lower than the drain-pan condensate connection to prevent the pan from overflowing. Prime the trap with water. Connect a drain tube using a minimum of 3/4-in. PVC or 3/4-in. copper pipe (all field-supplied) at the outlet end of the 2-in. trap. Do not undersize the tube. Pitch the drain tube downward at a slope of at least one in. for every 10 ft of horizontal run. Be sure to check the drain tube for leaks.

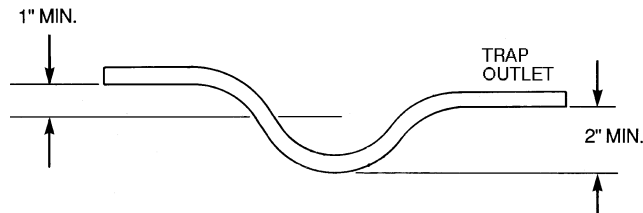

Fig. 14 — Condensate Trap

**Step 7 — Install Flue Hood** — The flue hood assembly is shipped screwed to the control box in the burner compartment. Remove the burner access panel to locate the assembly.

For units being installed in California Air Quality Management Districts which require NO<sub>x</sub> emissions of 40 nanograms/joule or less, kit CRLOWNOX001A00 must be installed.

### ⚠ CAUTION

The venting system is designed to ensure proper venting. The flue hood assembly must be installed as indicated in this section of the unit installation instructions.

Install the flue hood as follows:

1. This installation must conform with local building codes and with the National Fuel Gas Code (NFGC), ANSI Z223.1 (in Canada, CAN/CGA B149.1, and B149.2) or NFPA (National Fire Protection Association) latest revision. Refer

to Provincial and local plumbing or wastewater codes and other applicable local codes.

2. Remove from shipping location. Place vent cap assembly over flue panel. Orient screw holes in vent cap with holes in the flue panel.
3. Secure flue hood to flue panel by inserting a single screw on the right side, the left side, and the top of the hood.

**Step 8 — Install Gas Piping** — The gas supply pipe enters the unit through the access hole provided. The gas connection to the unit is made to the 1/2-in. FPT gas inlet on the manual shutoff or gas valve.

Install a gas supply line that runs to the heating section. Refer to Table 3 and the NFGC for gas pipe sizing. *Do not use cast-iron pipe.* It is recommended that a black iron pipe is used. Check the local utility for recommendations concerning existing lines. Size gas supply piping for 0.5 in. wg maximum pressure drop. *Never use pipe smaller than the 1/2-in. FPT gas inlet on the unit gas valve.*

For natural gas applications, the gas pressure at unit gas connection must not be less than 4.0 in. wg or greater than 13 in. wg while the unit is operating. For propane applications, the gas pressure must not be less than 4.0 in. wg or greater than 13 in. wg at the unit connection.

An 1/8-in. NPT plugged tapping accessible for test gage connection must be installed immediately upstream of the gas supply connection to the furnace.

When installing the gas supply line, observe local codes pertaining to gas pipe installations. Refer to the NFGC ANSI Z223.1-1988 NFPA latest edition (in Canada, CAN/CGA B149.1, (2)-M86). In the absence of local building codes, adhere to the following pertinent recommendations:

1. Avoid low spots in long runs of pipe. Grade all pipe 1/4 inch in every 15 ft to prevent traps. Grade all horizontal runs downward to risers. Use risers to connect to heating section and to meter.
2. Protect all segments of piping system against physical and thermal damage. Support all piping with appropriate straps, hangers, etc. Use a minimum of one hanger every 6 ft. For pipe sizes larger than 1/2 in., follow recommendations of national codes.
3. Apply joint compound (pipe dope) sparingly and only to male threads of joint when making pipe connections. Use only pipe dope that is resistant to action of liquefied petroleum gases as specified by local and/or national codes. *Never use Teflon tape.*
4. Install sediment trap in riser leading to heating section per Fig. 15. This drip leg functions as a trap for dirt and condensate.
5. Install an accessible, external, manual main shutoff valve in gas supply pipe within 6 ft of heating section.
6. Install ground-joint union close to heating section between unit manual shutoff and external manual main shutoff valve.
7. Pressure-test all gas piping in accordance with local and national plumbing and gas codes before connecting piping to unit.

NOTE: Pressure test the gas supply system *after* the gas supply piping is connected to the gas valve. The supply piping must be disconnected from the gas valve during the testing of the piping systems when test pressure is in excess of 0.5 psig. Pressure test the gas supply piping system at pressures equal to or less than 0.5 psig. The unit heating section must be isolated from the gas piping system by closing the external main manual shutoff valve and slightly opening the ground-joint union.

**Table 1 — Physical Data — Unit 48SS**

UNIT SIZE 48SS	018040	024040	024060	030040	030060	030080	036060	036080	036100	036120
NOMINAL CAPACITY (ton)	1½	2	2	2½	2½	2½	3	3	3	3
OPERATING WEIGHT (lb)										
Without Base Rail	272	303	315	320	332	332	336	336	348	348
With Optional Base Rail	296	327	339	344	356	356	360	360	372	372
COMPRESSORS	Rotary	Reciprocating								
Quantity	1	1								
REFRIGERANT (R-22)										
Charge (lb)	2.60	2.75	2.75	3.40	3.40	3.40	4.30	4.30	4.30	4.30
REFRIGERANT METERING DEVICE	Acutrol™ Device									
Orifice ID (in.)	.030	.030	.030	.030	.030	.030	.032	.032	.032	.032
CONDENSER COIL										
Rows...Fins/in.	1...17	1...17	1...17	2...17	2...17	2...17	2...17	2...17	2...17	2...17
Face Area (sq ft)	5.95	5.95	5.95	5.95	5.95	5.95	5.95	5.95	5.95	5.95
CONDENSER FAN										
Nominal Cfm	1700	1700	1700	1900	1900	1900	1900	1900	1900	1900
Diameter (in.)	18	18	18	18	18	18	18	18	18	18
Motor Hp (Rpm)	⅙ (850)	⅙ (850)	⅙ (850)	⅙ (850)	⅙ (850)	⅙ (850)	¼ (1050)	¼ (1050)	¼ (1050)	¼ (1050)
EVAPORATOR COIL										
Rows Fins/in.	3...15	3...15	3...15	3...15	3...15	3...15	3...15	3...15	3...15	3...15
Face Area (sq ft)	1.83	2.29	2.29	2.29	2.29	2.29	3.06	3.06	3.06	3.06
EVAPORATOR FAN	Direct Drive									
Nominal Airflow (Cfm)	600	800	800	1000	1000	1000	1200	1200	1200	1200
Size (in.)	10 x 10	10 x 10	10 x 10	10 x 10	10 x 10	10 x 10	10 x 10	10 x 10	10 x 10	10 x 10
Motor Hp	¼	¼	¼	¼	¼	¼	½	½	½	½
FURNACE SECTION*										
Burner Orifice (Qty...drill size)										
Natural Gas	1...32	1...32	2...40	1...32	2...40	2...32	2...40	2...32	2...30	3...32
Burner Orifice (Qty...drill size)										
Propane Gas	1...41	1...41	2...47	1...41	2...47	2...42	2...47	2...42	2...40	3...42
RETURN-AIR FILTERS (in.)†										
Throwaway	20 x 20	20 x 20	20 x 20	20 x 24	20 x 24	20 x 24	20 x 24	20 x 24	20 x 24	20 x 24

UNIT SIZE 48SS	042060	042080	042100	042120	048080	048100	048120	048140	060080	060100	060120	060140
NOMINAL CAPACITY (ton)	3½	3½	3½	3½	4	4	4	4	5	5	5	5
OPERATING WEIGHT (lb)												
Without Base Rail	375	375	387	387	414	426	426	426	453	465	465	465
With Optional Base Rail	399	399	411	411	438	450	450	450	477	489	489	489
COMPRESSORS	Reciprocating					Hermetic Scroll						
Quantity	1					1						
REFRIGERANT (R-22)												
Charge (lb)	5.20	5.20	5.20	5.20	6.50	6.50	6.50	6.50	7.00	7.00	7.00	7.00
REFRIGERANT METERING DEVICE	Acutrol Device											
Orifice ID (in.)	.034	.034	.034	.034	.030	.030	.030	.030	.030	.030	.030	.030
CONDENSER COIL												
Rows...Fins/in.	2...17	2...17	2...17	2...17	2...17	2...17	2...17	2...17	2...17	2...17	2...17	2...17
Face Area (sq ft)	7.04	7.04	7.04	7.04	8.67	8.67	8.67	8.67	8.67	8.67	8.67	8.67
CONDENSER FAN												
Nominal Cfm	1900	1900	1900	1900	2400	2400	2400	2400	2400	2400	2400	2400
Diameter (in.)	18	18	18	18	20	20	20	20	20	20	20	20
Motor Hp (Rpm)	¼ (1050)	¼ (1050)	¼ (1050)	¼ (1050)	⅓ (1050)	⅓ (1050)	⅓ (1050)	⅓ (1050)	⅓ (1050)	⅓ (1050)	⅓ (1050)	⅓ (1050)
EVAPORATOR COIL												
Rows Fins/in.	3...15	3...15	3...15	3...15	3...15	3...15	3...15	3...15	4...15	4...15	4...15	4...15
Face Area (sq ft)	3.33	3.33	3.33	3.33	4.44	4.44	4.44	4.44	4.44	4.44	4.44	4.44
EVAPORATOR FAN	Direct Drive											
Nominal Airflow (Cfm)	1400	1400	1400	1400	1600	1600	1600	1600	1995	1995	1995	1995
Size (in.)	10 x 10	10 x 10	10 x 10	10 x 10	10 x 10	10 x 10	10 x 10	10 x 10	10 x 11	10 x 11	10 x 11	10 x 11
Motor Hp	¾	¾	¾	¾	¾	¾	¾	¾	1	1	1	1
FURNACE SECTION*												
Burner Orifice (Qty...drill size)												
Natural Gas	2...40	2...32	2...30	3...32	2...32	2...30	3...32	3...31	2...32	2...30	3...32	3...31
Burner Orifice (Qty...drill size)												
Propane Gas	2...47	2...42	2...40	3...42	2...42	2...40	3...42	3...40	3...42	2...40	3...42	3...40
RETURN-AIR FILTERS (in.)†												
Throwaway	24 x 24	24 x 24	24 x 24	24 x 24	24 x 30	24 x 30	24 x 30	24 x 30	24 x 30	24 x 30	24 x 30	24 x 30

\*Based on altitude of 0-2000 feet.

†Required filter sizes shown are based on the larger of the ARI (Air Conditioning & Refrigeration Institute) rated cooling airflow or the heating airflow at a velocity of 300 ft/min for throwaway type or 450 ft/min for high-capacity type.

For non-standard air filters, air filter pressure drop must not exceed 0.08 in. wg.

**Table 2 — Physical Data — Unit 48SX**

UNIT SIZE 48SX	024040	024060	030040	030060	030080	036060	036080	036100	036120	
<b>NOMINAL CAPACITY (ton)</b>	2	2	2½	2½	2½	3	3	3	3	
<b>OPERATING WEIGHT (lb)</b> Without Base Rail With Optional Base Rail	333 357	345 369	336 360	348 372	348 372	366 390	366 390	378 402	378 402	
<b>COMPRESSORS</b> Quantity	Scroll 1									
<b>REFRIGERANT (R-22)</b> Charge (lb)	3.9	3.9	4.5	4.5	4.5	5.4	5.4	5.4	5.4	
<b>REFRIGERANT METERING DEVICE</b> Orifice ID (in.)	.034	.034	.030	.030	Acutrol™ Device .030		.032	.032	.032	
<b>CONDENSER COIL</b> Rows...Fins/in. Face Area (sq ft)	2...17 7.0	2...17 7.0	2...17 7.0	2...17 7.0	2...17 7.0	2...17 7.0	2...17 7.0	2...17 7.0	2...17 7.0	
<b>CONDENSER FAN</b> Nominal Cfm Diameter (in.) Motor Hp (Rpm)	2200 20 ¼ (1100)	2200 20 ¼ (1100)	2200 20 ¼ (1100)	2200 20 ¼ (1100)	2200 20 ¼ (1100)	2200 20 ¼ (1100)	2200 20 ¼ (1100)	2200 20 ¼ (1100)	2200 20 ¼ (1100)	
<b>EVAPORATOR COIL</b> Rows Fins/in. Face Area (sq ft)	2...15 3.6	2...15 3.6	3...15 2.7	3...15 2.7	3...15 2.7	4...15 3.6	4...15 3.6	4...15 3.6	4...15 3.6	
<b>EVAPORATOR FAN*</b> Nominal Airflow (Cfm) Size (in.) Motor Hp	800 10 x 10 ¼	800 10 x 10 ¼	1000 10 x 10 ¼	1000 10 x 10 ¼	Direct Drive 1000 10 x 10 ¼		1200 10 x 10 ½	1200 10 x 10 ½	1200 10 x 10 ½	1200 10 x 10 ½
<b>FURNACE SECTION†</b> Burner Orifice (Qty...drill size) Natural Gas Burner Orifice (Qty...drill size) Propane Gas	1...32 1...41	2...40 2...47	1...32 1...41	2...40 2...47	2...32 2...42	2...40 2...47	2...32 2...42	2...30 2...40	3...32 3...42	
<b>RETURN-AIR FILTERS (in.)**</b> Disposable	24 x 24	24 x 24	24 x 24	24 x 24	24 x 24	24 x 24	24 x 24	24 x 24	24 x 24	

UNIT SIZE 48SX	042060	042080	042100	042120	048080	048100	048120	048140	060080	060100	060120	060140
<b>NOMINAL CAPACITY (ton)</b>	3½	3½	3½	3½	4	4	4	4	5	5	5	5
<b>OPERATING WEIGHT (lb)</b> Without Base Rail With Optional Base Rail	391 415	391 415	403 427	403 427	422 446	434 458	434 458	434 458	453 477	465 489	465 489	465 489
<b>COMPRESSORS</b> Quantity	Scroll 1											
<b>REFRIGERANT (R-22)</b> Charge (lb)	5.7	5.7	5.7	5.7	5.8	5.8	5.8	5.8	7.00	7.00	7.00	7.00
<b>REFRIGERANT METERING DEVICE</b> Orifice ID (in.)	.034	.034	.034	.034	.034	.034	.034	.034	.030	.030	.030	.030
<b>CONDENSER COIL</b> Rows...Fins/in. Face Area (sq ft)	2...17 8.7	2...17 8.7	2...17 8.7	2...17 8.7	2...17 8.7	2...17 8.7	2...17 8.7	2...17 8.7	2...17 8.67	2...17 8.67	2...17 8.67	2...17 8.67
<b>CONDENSER FAN</b> Nominal Cfm Diameter (in.) Motor Hp (Rpm)	2400 20 ¼ (1100)	2400 20 ¼ (1100)	2400 20 ¼ (1100)	2400 20 ¼ (1100)	2400 20 ¼ (1100)	2400 20 ¼ (1100)	2400 20 ¼ (1100)	2400 20 ¼ (1100)	2400 20 ⅓ (1050)	2400 20 ⅓ (1050)	2400 20 ⅓ (1050)	2400 20 ⅓ (1050)
<b>EVAPORATOR COIL</b> Rows Fins/in. Face Area (sq ft)	3...15 4.4	3...15 4.4	3...15 4.4	3...15 4.4	4...15 4.4	4...15 4.4	4...15 4.4	4...15 4.4	4...15 4.44	4...15 4.44	4...15 4.44	4...15 4.44
<b>EVAPORATOR FAN*</b> Nominal Airflow (Cfm) Size (in.) Motor Hp	1400 10 x 10 ¾	1400 10 x 10 ¾	1400 10 x 10 ¾	1400 10 x 10 ¾	1600 10 x 10 ¾	1600 10 x 10 ¾	1600 10 x 10 ¾	1600 10 x 10 ¾	1995 10 x 11 1	1995 10 x 11 1	1995 10 x 11 1	1995 10 x 11 1
<b>FURNACE SECTION†</b> Burner Orifice (Qty...drill size) Natural Gas Burner Orifice (Qty...drill size) Propane Gas	2...40 2...47	2...32 2...42	2...30 2...40	3...32 3...42	2...32 2...42	2...30 2...40	3...32 3...42	3...31 3...40	2...32 3...42	2...30 2...40	3...32 3...42	3...31 3...40
<b>RETURN-AIR FILTERS (in.)**</b> Disposable	24 x 30	24 x 30	24 x 30	24 x 30	24 x 30	24 x 30	24 x 30	24 x 30	24 x 30	24 x 30	24 x 30	24 x 30

\*Size 048 evaporator fan is equipped with a 460-v or integrated control motor (ICM). Size 060 evaporator fan is equipped with an ICM only. The ICM provides variable speed.

†Based on an altitude of 0-2000 feet.

\*\*Required filter sizes shown are based on the ARI (Air Conditioning & Refrigeration Institute) rated heating airflow at a velocity of 300 ft/min for throwaway type or 450 ft/min for high-capacity type. For non-standard air filters, air filter pressure drop must not exceed 0.08 in. wg.

**⚠ CAUTION**

Unstable operation may occur when the gas valve and manifold assembly are forced out of position while connecting improperly-routed rigid gas piping to the gas valve. Use a backup wrench when making connection to avoid strain on, or distortion of, the gas control piping.

**⚠ CAUTION**

If a flexible conductor is required or allowed by the authority having jurisdiction, black iron pipe shall be installed at the gas valve and shall extend a minimum of 2 in. outside the unit casing.

**⚠ WARNING**

Never use a match or other open flame when checking for gas leaks. Never purge gas line into combustion chamber. Failure to follow this warning could result in an explosion causing personal injury or death.

8. Check for gas leaks at the field-installed and factory-installed gas lines after all piping connections have been completed. Use soap-and-water solution (or method specified by local codes and/or regulations).

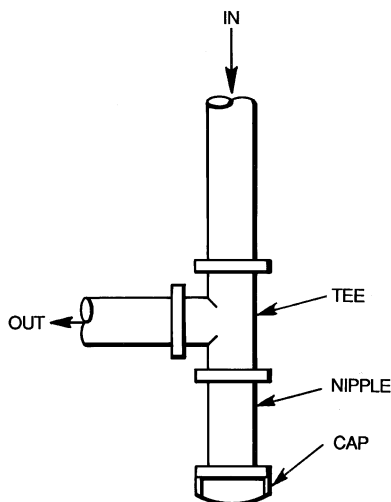

**Fig. 15 — Sediment Trap**

**Step 9 — Install Duct Connections** — The unit has duct flanges on the supply- and return-air openings on the side and bottom of the unit. See Fig. 2-9 for connection sizes and locations.

**CONFIGURING UNITS FOR DOWNFLOW (VERTICAL) DISCHARGE**

**⚠ WARNING**

Before performing service or maintenance operations on the system, turn off main power to unit or electrical shock could result.

1. Open all electrical disconnects before starting any service work.
2. Remove return duct cover located on duct panel. Figure 16 shows duct cover removed. Save duct cover and screws.
3. Locate lances in basepan insulation that are placed over the perimeter of the vertical duct opening cover (Fig. 17).
4. Using a straight edge and sharp knife, cut and remove the insulation around the perimeter of the cover. Remove and save 5 screws securing the cover to the basepan and slide out the cover. Discard the cover (Fig. 18).
5. Remove supply duct cover located on duct panel. Figure 16 shows duct cover removed. Save duct cover and screws.
6. Remove and discard 2 screws which secure vertical discharge opening cover to basepan (Fig. 19). Slide cover forward to disengage, then tilt and remove cover through vertical discharge opening in bottom of unit. Discard duct cover (Fig. 20).

**⚠ CAUTION**

Collect ALL screws that were removed. Do not leave screws on rooftop as permanent damage to the roof may occur.

7. If unit ductwork is to be attached to vertical opening flanges on the unit basepan (jackstand applications only), do so at this time.
8. It is recommended that the basepan insulation around the perimeter of the vertical return-air opening be secured to the basepan with aluminum tape. Applicable local codes may require aluminum tape to prevent exposed fiberglass.
9. Cover both horizontal duct openings with the duct covers from Steps 2 and 5. Make sure opening is air- and watertight.
10. After completing unit conversion, perform all safety checks and power up unit.

**NOTE:** The design and installation of the duct system must be in accordance with the standards of the NFPA for installation of nonresidence-type air conditioning and ventilating systems, NFPA 90A or residence-type, NFPA 90B; and/or local codes and residence-type, NFPA 90B; and/or local codes and ordinances.

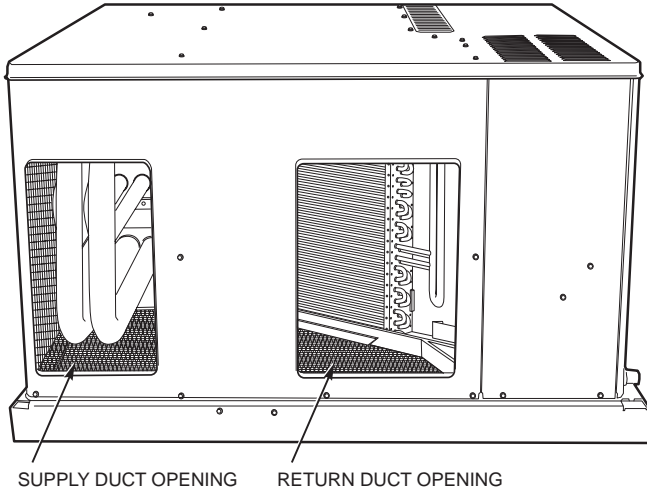

**Table 3 — Maximum Gas Flow Capacity\***

NOMINAL IRON PIPE, SIZE (in.)	INTERNAL DIAMETER (in.)	LENGTH OF PIPE, FT†													
		10	20	30	40	50	60	70	80	90	100	125	150	175	200
1/2	.622	175	120	97	82	73	66	61	57	53	50	44	40	—	—
3/4	.824	360	250	200	170	151	138	125	118	110	103	93	84	77	72
1	1.049	680	465	375	320	285	260	240	220	205	195	175	160	145	135
1 1/4	1.380	1400	950	770	600	580	530	490	460	430	400	360	325	300	280
1 1/2	1.610	2100	1460	1180	990	900	810	750	690	650	620	550	500	460	430

\*Capacity of pipe in cu ft of gas per hr for gas pressure of 0.5 psig or less. Pressure drop of 0.5-in. wg (based on a 0.60 specific gravity gas). Refer to Table C-4, National Fire Protection Association NFPA 54.

†This length includes an ordinary number of fittings.



**Fig. 16 — Supply and Return Duct Openings**

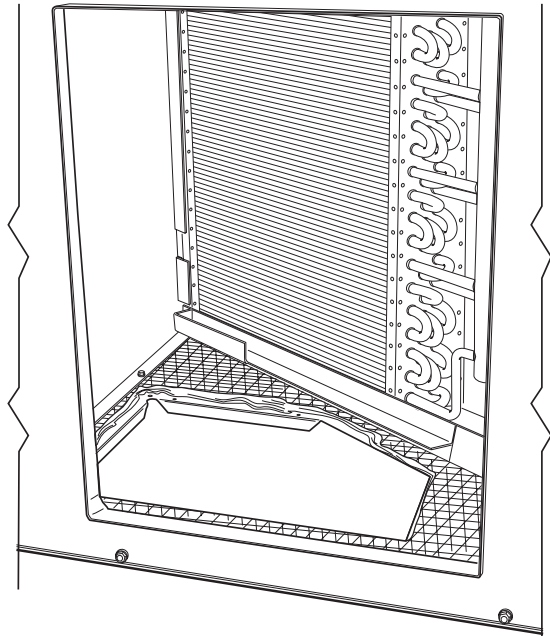

**Fig. 18 — Vertical Duct Cover Removed**

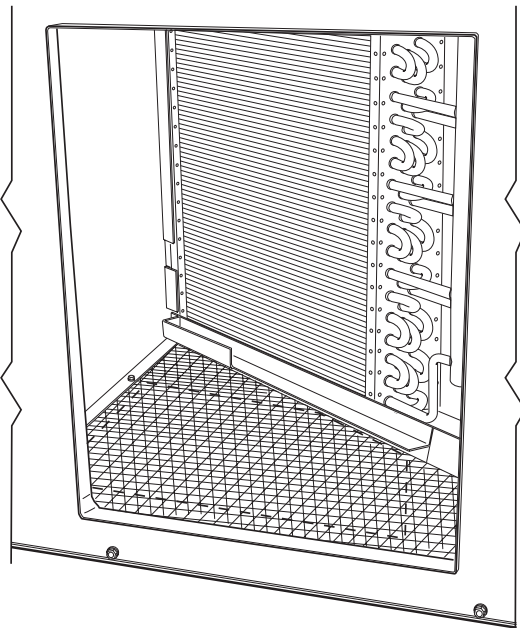

**Fig. 17 — Lance Location for Vertical Duct Opening Cover**

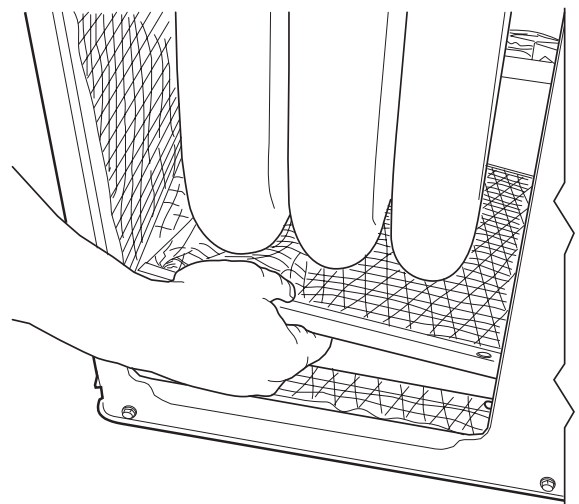

**Fig. 19 — Removal of Vertical Discharge Opening Cover**

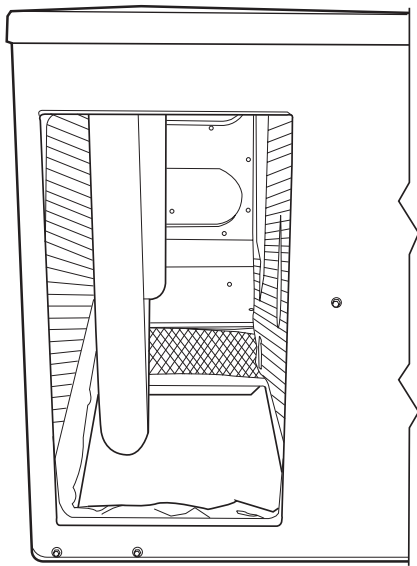

**Fig. 20 — Vertical Discharge Cover Removed**

Adhere to the following criteria when selecting, sizing, and installing the duct system:

1. Units are shipped with all 4 duct openings covered. Remove appropriate panels for intended installation.
2. Select and size ductwork, supply-air registers, and return-air grilles according to American Society of Heating, Refrigeration and Air Conditioning Engineers (ASHRAE) recommendations.
3. Use flexible transition between rigid ductwork and unit to prevent transmission of vibration. The transition may be screwed or bolted to duct flanges. Use suitable gaskets to ensure weathertight and airtight seal.
4. All units must have field-supplied filters or accessory filter rack installed in the return-air side of the unit. Recommended sizes for filters are shown in Tables 1 and 2.
5. Size all ductwork for maximum required airflow (either heating or cooling) for unit being installed. Avoid abrupt duct size increases or decreases or performance may be affected.
6. Adequately insulate and weatherproof all ductwork located outdoors. Insulate ducts passing through unconditioned space, and use vapor barrier in accordance with latest issue of Sheet Metal and Air Conditioning Contractors National Association (SMACNA) and Air Conditioning Contractors of America (ACCA) minimum installation standards for heating and air-conditioning systems. Secure all ducts to building structure.
7. Flash, weatherproof, and vibration-isolate all openings in building structure in accordance with local codes and good building practices.

## Step 10 — Install Electrical Connections

### ⚠ WARNING

The unit cabinet must have an uninterrupted, unbroken electrical ground to minimize the possibility of personal injury if an electrical fault should occur. This ground may consist of an electrical wire connected to the unit ground lug in the control compartment, or conduit approved for electrical ground when installed in accordance with NEC (National Electrical Code) ANSI/NFPA (latest edition) (in Canada, Canadian Electrical Code CSA [Canadian Standards Association] C22.1) and local electrical codes. *Do not use gas piping as an electrical ground.* Failure to adhere to this warning could result in personal injury or death.

### ⚠ CAUTION

Failure to follow these precautions could result in damage to the unit being installed:

1. Make all electrical connections in accordance with NEC ANSI/NFPA (latest edition) and local electrical codes governing such wiring. In Canada, all electrical connections must be in accordance with CSA standard C22.1 Canadian Electrical Code Part 1 and applicable local codes. Refer to unit wiring diagram.
2. Use only *copper* conductor for connections between field-supplied electrical disconnect switch and unit. **DO NOT USE ALUMINUM WIRE.**
3. Be sure that high-voltage power to unit is within operating voltage range indicated on unit rating plate.
4. Do not damage internal components when drilling through any panel to mount electrical hardware, conduit, etc. On 3-phase units, ensure phases are balanced within 2%. Consult local power company for correction of improper voltage and/or phase imbalance.

**HIGH-VOLTAGE CONNECTIONS** — The unit must have a separate electrical service with a field-supplied, waterproof, disconnect switch mounted at, or within sight from, the unit. Refer to the unit rating plate for maximum fuse/circuit breaker size and minimum circuit amps (ampacity) for wire sizing. See Tables 4A and 4B for electrical data.

The field-supplied disconnect switch box may be mounted on the unit over the high-voltage inlet hole when the standard power and low-voltage entry points are used. See Fig. 2-9 for acceptable location.

**Standard Power Entry** — Proceed as follows to complete the high-voltage connections to the unit:

1. Connect ground lead to chassis ground connection when using separate ground wire.
2. Run high-voltage leads into unit control box.
3. Locate black and yellow wires connected to line side of contactor.
4. Cut wires at partition where they exit control box.
5. Strip back leads and connect to high voltage leads. On 3-phase units, blue wire is provided stripped back and ready to connect to high voltage lead. See unit wiring label and Fig. 21.

Table 4A — Electrical Data — Unit 48SS

UNIT SIZE 48SS	V-PH-Hz	VOLTAGE RANGE		COMPRESSOR		OUTDOOR-FAN MOTOR	INDOOR-FAN MOTOR	POWER SUPPLY		AWG 60 C MIN WIRE SIZE	MAX WIRE LENGTH (ft)
		Min	Max	RLA	LRA	FLA	FLA	MCA	MOCPS*		
018	208/230-1-60	187	253	8.3	45.0	0.7	1.8	12.9	15	14	75
024	208/230-1-60	187	253	12.4	61.0	0.7	2.0	18.2	30	12	80
030	208/230-1-60	187	253	14.4	82.0	1.4	2.3	21.4	30	10	100
	208/230-3-60	187	253	9.4	66.0	1.4	2.0	15.1	25	12	80
036	208/230-1-60	187	253	18.0	96.0	1.4	2.8	26.7	40	10	90
	208/230-3-60	187	253	11.7	75.0	1.4	2.8	18.8	30	12	65
	460-3-60	414	506	5.6	40.0	0.8	1.4	9.2	10	14	100
042	208/230-1-60	187	253	20.4	104.0	1.4	4.0	30.9	50	8	100
	208/230-3-60	187	253	14.0	91.0	1.4	4.0	22.9	35	10	85
	460-3-60	414	506	6.4	42.0	0.8	2.0	10.8	15	14	100
048	208/230-1-60†	187	253	21.8	124.0	2.1	5.0	40.1	60	8	100
	208/230-1-60**	187	253	26.4	129.0	2.1	5.0	40.1	60	6	100
	208/230-3-60†	187	253	12.8	93.0	2.1	5.0	25.9	40	10	75
	208/230-3-60**	187	253	15.0	99.0	2.1	5.0	25.9	40	10	75
	460-3-60†	414	506	6.4	46.5	1.1	2.3	13.7	20	14	100
	460-3-60**	414	506	8.2	50.0	1.1	2.3	13.7	20	14	100
060	208/230-1-60	187	253	32.1	169.0	2.1	6.8	49.0	60	6	100
	208/230-3-60	187	253	19.3	123.0	2.1	6.8	33.0	50	8	90
	460-3-60	414	506	10.0	62.0	1.1	3.2	16.8	25	12	100

LEGEND

- AWG — American Wire Gage
- FLA — Full Load Amps
- HACR — Heating, Air Conditioning and Refrigeration
- LRA — Locked Rotor Amps
- MCA — Minimum Circuit Amps
- MOCPS — Maximum Overcurrent Protection
- RLA — Rated Load Amps



Example: Supply voltage is 460-3-60.

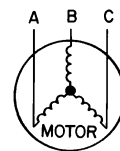

- AB = 452 v
- BC = 464 v
- AC = 455 v

$$\begin{aligned} \text{Average Voltage} &= \frac{452 + 464 + 455}{3} \\ &= \frac{1371}{3} \\ &= 457 \end{aligned}$$

Determine maximum deviation from average voltage.

- (AB) 457 - 452 = 5 v
- (BC) 464 - 457 = 7 v
- (AC) 457 - 455 = 2 v

Maximum deviation is 7 v.

Determine percent of voltage imbalance.

$$\begin{aligned} \% \text{ Voltage Imbalance} &= 100 \times \frac{7}{457} \\ &= 1.53\% \end{aligned}$$

This amount of phase imbalance is satisfactory as it is below the maximum allowable 2%.

**IMPORTANT:** If the supply voltage phase imbalance is more than 2%, contact your local electric utility company immediately.

NOTES:

1. In compliance with NEC (National Electrical Code) requirements for multimotor and combination load equipment (refer to NEC Articles 430 and 440), the overcurrent protective device for the unit shall be fuse or HACR breaker. The CGA (Canadian Gas Association) units may be fuse or circuit breaker.
2. Minimum wire size is based on 60 C copper wire. If other than 60 C wire is used, or if length exceeds wire length in table, determine size from NEC.
3. **Unbalanced 3-Phase Supply Voltage**  
Never operate a motor where a phase imbalance in supply voltage is greater than 2%. Use the following formula to determine the percentage of voltage imbalance.

% Voltage imbalance

$$= 100 \times \frac{\text{max voltage deviation from average voltage}}{\text{average voltage}}$$

Table 4B — Electrical Data — Unit 48SX

UNIT SIZE 48SX	V-PH-Hz	VOLTAGE RANGE		COMPRESSOR		OUTDOOR-FAN MOTOR	INDOOR-FAN MOTOR	POWER SUPPLY		AWG 60 C MIN WIRE SIZE	MAX WIRE LENGTH (ft)
		Min	Max	RLA	LRA	FLA	FLA	MCA	MOCP*		
024	208/230-1-60	187	253	12.9	62.5	1.4	2.0	19.5	30	12	75
030	208/230-1-60	187	253	15.0	76.0	1.4	2.6	22.8	30	10	100
	208/230-1-60	187	253	16.7	95.0	1.4	2.8	25.1	30	10	95
036	208/230-3-60	187	253	10.9	75.0	1.4	2.8	17.8	25	12	70
	460-3-60	414	506	5.4	40.0	0.8	1.4	9.0	10	14	100
042	208/230-1-60	187	253	20.0	104.0	1.4	3.1	29.5	45	10	80
	208/230-3-60	187	253	13.9	88.0	1.4	3.1	21.9	30	10	60
	460-3-60	414	506	6.8	44.0	0.8	1.6	10.9	15	14	100
048	208/230-1-60	187	253	26.4	129.0	1.4	7.2	41.6	60	6	100
	208/230-3-60	187	253	15.0	99.0	1.4	7.2	27.4	40	10	70
	460-3-60	414	506	8.2	49.5	0.8	2.3	13.4	20	14	100
060	208/230-1-60	187	253	32.1	169.0	2.1	7.2	49.4	60	6	100
	208/230-3-60	187	253	19.3	123.0	2.1	7.2	33.4	50	8	90

LEGEND

- AWG — American Wire Gage
- FLA — Full Load Amps
- HACR — Heating, Air Conditioning and Refrigeration
- LRA — Locked Rotor Amps
- MCA — Minimum Circuit Amps
- MOCP — Maximum Overcurrent Protection
- RLA — Rated Load Amps

\*Fuse or HACR Breaker.  
 † Carrier Scroll Compressor.  
 \*\*Copeland Scroll Compressor.



Example: Supply voltage is 460-3-60.

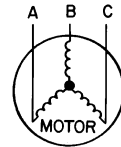

AB = 452 v  
 BC = 464 v  
 AC = 455 v

$$\begin{aligned} \text{Average Voltage} &= \frac{452 + 464 + 455}{3} \\ &= \frac{1371}{3} \\ &= 457 \end{aligned}$$

Determine maximum deviation from average voltage.

(AB) 457 - 452 = 5 v  
 (BC) 464 - 457 = 7 v  
 (AC) 457 - 455 = 2 v

Maximum deviation is 7 v.

Determine percent of voltage imbalance.

$$\begin{aligned} \% \text{ Voltage Imbalance} &= 100 \times \frac{7}{457} \\ &= 1.53\% \end{aligned}$$

This amount of phase imbalance is satisfactory as it is below the maximum allowable 2%.

**IMPORTANT:** If the supply voltage phase imbalance is more than 2%, contact your local electric utility company immediately.

NOTES:

1. In compliance with NEC (National Electrical Code) requirements for multimotor and combination load equipment (refer to NEC Articles 430 and 440), the overcurrent protective device for the unit shall be fuse or HACR breaker. The CGA (Canadian Gas Association) units may be fuse or circuit breaker.
2. Minimum wire size is based on 60 C copper wire. If other than 60 C wire is used, or if length exceeds wire length in table, determine size from NEC.
3. **Unbalanced 3-Phase Supply Voltage**  
*Never operate a motor where a phase imbalance in supply voltage is greater than 2%. Use the following formula to determine the percentage of voltage imbalance.*

$$\begin{aligned} \% \text{ Voltage imbalance} \\ &= 100 \times \frac{\text{max voltage deviation from average voltage}}{\text{average voltage}} \end{aligned}$$

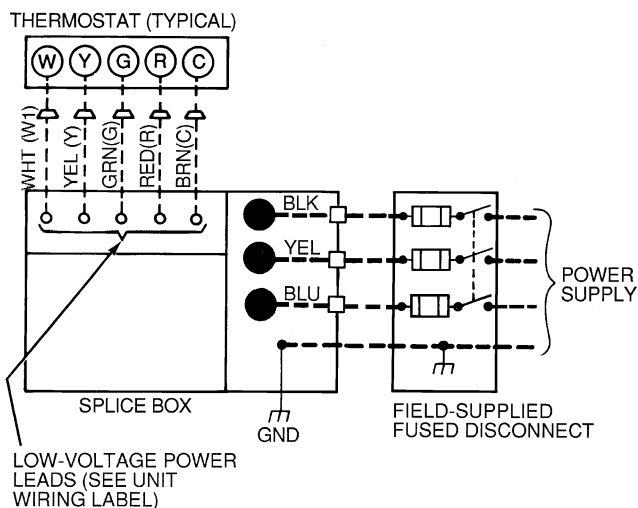

LEGEND  
 - - - - Field Control-Voltage Wiring  
 - - - - Field High-Voltage Wiring  
 NOTE: Use blue wire for 3-phase units only.

**Fig. 21 — High- and Control-Voltage Connections**

Alternate Power Entry

1. Remove knockouts in fixed compressor panel located on duct panel side of unit.
2. Route high-voltage leads into high-voltage terminal box.
3. Connect ground wire to green-yellow wire using field-supplied splice.
4. Connect power wires to unit high-voltage leads.
5. On 3-phase units, locate blue wire projecting from compressor junction box. Cut wire at partition and route into high-voltage junction box through grommet in back of junction box.
6. On 3-phase units, strip back blue lead and connect to third leg of the power wires.

SPECIAL PROCEDURES FOR 208-V OPERATION

**⚠ WARNING**

Make sure that the gas supply *then* the power supply to the unit is switched OFF before making any wiring changes. Electrical shock can cause personal injury or death.

1. Disconnect the orange transformer-primary lead from the contactor. See unit wiring label.
2. Remove the tape and wrenut from the terminal on the end of the red transformer-primary lead.
3. Save the wrenut.
4. Connect the red lead to the contactor terminal from which the orange lead was disconnected.
5. Using the wrenut removed from the red lead, insulate the loose terminal on the orange lead.
6. Wrap the cover with electrical tape so that the metal terminal cannot be seen.

**CONTROL VOLTAGE CONNECTIONS; NON-INTEGRATED CONTROL MOTOR (NON-ICM) UNITS** — Locate the room thermostat on an inside wall in the space to be conditioned, where it will not be subjected to either a cooling or heating source or direct exposure to sunlight. Mount the thermostat 4 to 5 ft above the floor.

NOTE: Do not use any type of power-stealing thermostat. Unit control problems may result.

Use no. 18 American Wire Gage (AWG) color-coded, insulated (35 C minimum) wires to make the control voltage connections between the thermostat and the unit. If the thermostat is located more than 100 ft from the unit (as measured along the control voltage wires), use no. 16 AWG color-coded, insulated (35 C minimum) wires.

Standard Connection — Remove knockout hole located in the flue panel adjacent to the control access panel. See Fig. 2-9. Remove the rubber grommet from the installer's packet (included with unit) and install grommet in the knockout opening. Provide a drip loop before running wire through panel.

Run the low-voltage leads from the thermostat, through the inlet hole, and into unit low-voltage splice box.

Locate five 18-gage wires leaving control box. These low-voltage connection leads can be identified by the colors red, green, yellow, brown, and white. (See Fig. 21.) Ensure the leads are long enough to be routed into the low-voltage splice box (located below right side of control box). Cut wires at the point where they exit control box; do NOT cut yellow wire on 48SX024,030 units. Stripped yellow wire is located in connection box. Route leads through hole in bottom of control box and make low-voltage connections as shown in Fig. 21. Secure all cut wires, so that they do not interfere with operation of unit.

Alternate Connection — Remove knockout in compressor fixed panel located below high-voltage knockout. Remove the rubber grommet from the installer's packet (included with unit) and install grommet in the knockout opening. Route thermostat wires through grommet providing drip loop at panel. Connect low-voltage leads as shown in Fig. 21. On 48SX024 and 030 units, the yellow wire originating from discharge thermostat of compressor must be cut and routed into low-voltage section of junction box.

**CONTROL VOLTAGE CONNECTIONS; INTEGRATED CONTROL MOTOR (ICM) UNITS**

Routing Control Power Wires (24 v) — Remove knockout in the compressor fixed access panel located below the high-voltage knockout. Remove the rubber grommet from the installer's packet (included with unit) and install grommet in the knockout opening. Route thermostat wires through grommet providing drip loop at panel. Connect low-voltage leads to the thermostat.

Alternate Connection (24 v) — Remove knockout in the flue panel adjacent to the control access panel. Remove the rubber grommet from the installer's packet (included with unit) and install grommet in the knockout opening. Provide a drip loop before running wire through panel. Run the low-voltage leads from the thermostat, through the inlet hole, and into the unit low-voltage splice box.

Connecting to Easy Select Interface Board — The Easy Select interface board is located in the control box area. The Easy Select interface board is factory wired to the motor, and factory default selections are preset.

Locate the five 18-gage thermostat lead wires of plug assembly 1 (PL1) attached to the Easy Select interface board (See Fig. 22 and wiring diagrams for units 48SX048 and 060 on pages 31 and 33.) These low voltage connection leads are identified by the colors red, green, yellow, brown, and white. Cut the wires between the 2 wire ties approximately 4 in. from the plug. Connect low-voltage leads to the thermostat. Secure all cut wires in the control and splice boxes so they do not interfere with the proper operation of the unit.

## PRE-START-UP

### ⚠ WARNING

Failure to observe the following warnings could result in serious personal injury:

1. Follow recognized safety practices and wear protective goggles when checking or servicing refrigerant system.
2. Do not operate compressor or provide any electric power to unit unless compressor terminal cover is in place and secured.
3. Do not remove compressor terminal cover until all electrical sources are disconnected.
4. Relieve and reclaim all refrigerant from system before touching or disturbing anything inside terminal box if refrigerant leak is suspected around compressor terminals.
5. Never attempt to repair soldered connection while refrigerant system is under pressure.
6. Do not use torch to remove any component. System contains oil and refrigerant under pressure. To remove a component, wear protective goggles and proceed as follows:
  - a. Shut off gas supply and *then* electrical power to unit.
  - b. Relieve and reclaim all refrigerant from system using both high- and low-pressure ports.
  - c. Cut component connecting tubing with tubing cutter and remove component from unit.
  - d. Carefully unsweat remaining tubing stubs when necessary. Oil can ignite when exposed to torch flame.

Proceed as follows to inspect and prepare the unit for initial start-up:

1. Remove all access panels.
2. Read and follow instructions on all WARNING, CAUTION, and INFORMATION labels attached to, or shipped with, unit.
3. Make the following inspections:
  - a. Inspect for shipping and handling damages such as broken lines, loose parts, disconnected wires, etc.
  - b. Inspect for oil at all refrigerant tubing connections and on unit base. Detecting oil generally indicates a refrigerant leak. Leak-test all refrigerant tubing connections using electronic leak detector, halide torch, or liquid-soap solution. If a refrigerant leak is detected, see Check for Refrigerant Leaks section on page 23.
  - c. Inspect all field- and factory-wiring connections. Be sure that connections are completed and tight.
  - d. Inspect coil fins. If damaged during shipping and handling, carefully straighten fins with a fin comb.
4. Verify the following conditions:

### ⚠ CAUTION

Do not purge gas supply into the combustion chamber. Do not use a match or other open flame to check for gas leaks. Failure to follow this warning could result in an explosion causing personal injury or death.

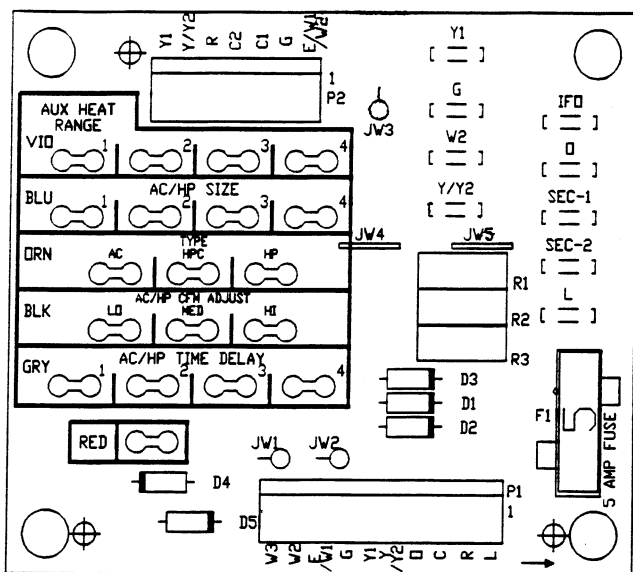

#### LEGEND

IFO — Indoor (Evaporator) Fan On  
 JW — Jumper Wire

**Fig. 22 — Easy Select Interface Board**

**HEAT ANTICIPATOR SETTING** — The room thermostat heat anticipator must be properly adjusted to ensure proper heating performance. Set the heat anticipator, using an ammeter between the W and R terminals to determine the exact required setting.

**NOTE:** For thermostat selection purposes, use 0.18 amp for the approximate required setting.

Failure to make a proper heat anticipator adjustment will result in improper operation, discomfort to the occupants of the conditioned space, and inefficient energy utilization; however, the required setting may be changed slightly to provide a greater degree of comfort for a particular installation.

**TRANSFORMER PROTECTION** — The unit transformer protection may be one of 2 types.

*The first transformer type* may contain an auto. reset overcurrent protector for control circuit protection. If this device trips, it may reset without warning, starting the heating or cooling section of this product. Use caution when servicing; if overcurrent protector continues to trip, there is a problem in the low-voltage electrical circuit, such as an electrical short, ground, or transformer overload. Disconnect power, correct the condition, and check for normal unit operation.

*The second transformer type* is of the energy-limiting type. It is set to withstand a 30-second overload or shorted secondary condition.

- Before lighting the unit for the first time, perform the following: If the gas supply pipe was not purged before connecting the unit, it will be full of air. It is recommended that the ground joint union be loosened, and the supply line be allowed to purge until the odor of gas is detected. Never purge gas lines into a combustion chamber. Immediately upon detection of gas odor, retighten the union. Allow 5 minutes to elapse, then light unit.
- Make sure that condenser-fan blade is correctly positioned in fan orifice. Leading edge of condenser-fan blade should be  $\frac{1}{2}$  in. maximum from plastic fan orifice (see Fig. 23).
- Make sure that air filter(s) is in place.
- Make sure that condensate drain trap is filled with water to ensure proper drainage.
- Make sure that all tools and miscellaneous loose parts have been removed.

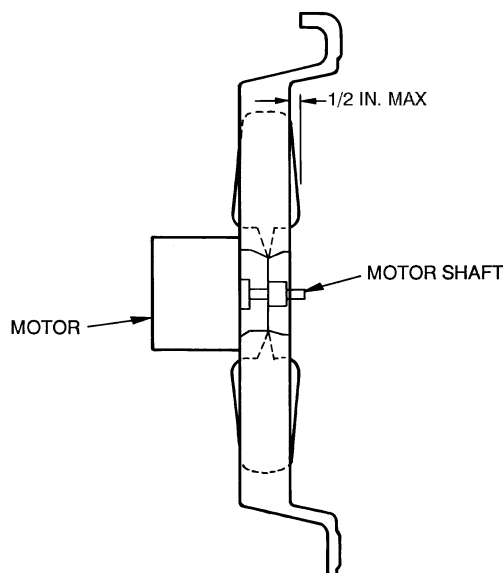

**Fig. 23 — Fan Blade Clearance**

## START-UP

**Check for Refrigerant Leaks** — Proceed as follows to locate and repair a refrigerant leak and to charge the unit:

- Locate leak and make sure that refrigerant system pressure has been relieved and reclaimed from both high- and low-pressure ports.
- Repair leak following accepted practices.  
NOTE: Install a filter drier whenever the system has been opened for repair.
- Add a small charge of R-22 refrigerant vapor to system and leak-test unit.
- Evacuate and reclaim refrigerant from refrigerant system if additional leaks are not found.
- Charge unit with R-22 refrigerant, using a volumetric-charging cylinder or accurate scale. *Refer to unit rating plate for required charge.* Be sure to add extra refrigerant to compensate for internal volume of filter drier.

## Start Up Heating Section and Make Adjustments

### ⚠ CAUTION

Complete the required procedures given in Pre-Start-Up section on page 22 before starting the unit.

Do not jumper any safety devices when operating the unit.

Make sure that burner orifices are properly aligned. Unstable operation may occur when the burner orifices in the manifold are misaligned.

Follow the lighting instructions on the heating section operation label (located inside the burner or blower access door) to start the heating section.

NOTE: Make sure that gas supply has been purged, and that all gas piping has been checked for leaks.

**CHECK HEATING CONTROL** — Start and check the unit for proper heating control operation as follows. (See furnace lighting instructions located inside burner or blower access panel.)

- Place the room thermostat SYSTEM switch in the HEAT position and the fan switch in the AUTO. position.
- Set the heating temperature control of the thermostat above room temperature.
- The induced-draft motor will start.
- After a call for heating, the main burner should light within 5 seconds. If the burners do not light, there is a 22-second delay before another 5-second try. If the burners still do not light, this sequence is repeated. If the burners do not light within 15 minutes from the initial call for heat, there is a lockout. To reset the control, break the 24-v power to W.
- The evaporator fan will turn on 45 seconds after the flame has been established. The evaporator fan will turn off 45 seconds after the thermostat has been satisfied.

**CHECK GAS INPUT** — Check gas input and manifold pressure after unit start-up. (See Table 5.) If adjustment is required proceed as follows.

The rated gas inputs shown in Table 5 are for altitudes from sea level to 2000 ft above sea level. These inputs are based on natural gas with a heating value of 1050 Btu/ft<sup>3</sup> at 0.65 specific gravity, or propane gas with a heating value of 2500 Btu/ft<sup>3</sup> at 1.5 specific gravity. For elevations above 2000 ft, reduce input 4% for each 1000 ft above sea level. When the gas supply being used has a different heating value or specific gravity, refer to national and local codes, or contact your distributor to determine the required orifice size.

### ⚠ CAUTION

These units are designed to consume the rated gas inputs using the fixed orifices at specified manifold pressures as shown in Table 5. **DO NOT REDRILL THE ORIFICES UNDER ANY CIRCUMSTANCES.**

**ADJUST GAS INPUT** — The gas input to the unit is determined by measuring the gas flow at the meter or by measuring the manifold pressure. Measuring the gas flow at the meter is recommended for natural gas units. The manifold pressure must be measured to determine the input of propane gas units.



**Table 5 — Rated Gas Inputs at Indicated Manifold Pressures**

UNIT 48SS,SX	NUMBER OF ORIFICES	GAS SUPPLY PRESSURE (in. wg)				MANIFOLD PRESSURE (in. wg)		NATURAL GAS		PROPANE*	
		Natural		Propane		Natural	Propane	Orifice Drill Size	Heating Input (Btuh)†	Orifice Drill Size	Heating Input (Btuh)†
		Min	Max	Min	Max						
018040, 024040, 030040	1	4.0	13.0	4.0	13.0	3.5	3.1	32	40,000	41	40,000
024060, 030060, 036060, 042060	2	4.0	13.0	4.0	13.0	3.5	3.3	40	56,000	47	54,000
030080, 036080, 042080, 048080, 060080	2	4.0	13.0	4.0	13.0	3.5	3.4	32	80,000	42	80,000
036100, 042100, 048100, 060100	2	4.0	13.0	4.0	13.0	3.5	3.7	30	95,000	40	95,000
036120, 042120, 048120, 060120	3	4.0	13.0	4.0	13.0	3.5	3.5	32	120,000	42	115,000
048140, 060140	3	4.0	13.0	4.0	13.0	3.5	3.4	31	136,000	40	133,000

\*When a unit is converted to propane, different size orifices must be used. See separate natural-to-propane conversion kit instructions.

†Based on altitudes from sea level to 2000 ft above sea level. For altitudes above 2000 ft: reduce input rating 4% for each additional 1000 ft above 2000 ft. In Canada, from 2000 ft above sea level to 4500 ft above sea level, derate the unit 10%.

NOTE: Unit size 018 is 48SS only.

**Measure Gas Flow (Natural Gas Units)** — Minor adjustment to the gas flow can be made by changing the manifold pressure. The manifold pressure must be maintained between 3.4 and 3.6 in. wg. If larger adjustments are required, change main burner orifices following the recommendations of national and local codes.

NOTE: All other appliances that use the same meter must be turned off when gas flow is measured at the meter.

Proceed as follows:

1. Turn off gas supply to unit.
2. Remove pipe plug on manifold (see Fig. 24), then connect manometer at this point. Turn on gas to unit.
3. Record number of seconds for gas meter test dial to make one revolution.
4. Divide number of seconds in Step 3 into 3600 (number of seconds in one hour).
5. Multiply result of Step 4 by the number of cu ft shown for one revolution of test dial to obtain cu ft of gas flow per hour.
6. Multiply result of Step 5 by Btu heating value of gas to obtain total measured input in Btuh. Compare this value with heating input shown in Table 5. (Consult the local gas supplier if the heating value of gas is not known.)

EXAMPLE: Assume that the size of test dial is 1 cu ft, one revolution takes 30 seconds, and the heating value of the gas is 1050 Btu/ft<sup>3</sup>. Proceed as follows:

1. 30 seconds to complete one revolution.
2.  $3600 \div 30 = 120$ .
3.  $120 \times 1 = 120 \text{ ft}^3$  of gas flow/hr.
4.  $120 \times 1050 = 126,000$  Btuh input.

If the desired gas input is 120,000 Btuh, only a minor change in the manifold pressure is required.

Observe manifold pressure and proceed as follows to adjust gas input:

1. Remove cover screw over regulator adjustment screw on gas valve.
2. Turn regulator adjustment screw clockwise to increase gas input, or turn regulator adjustment screw counterclockwise to decrease input. Manifold pressure must be between 3.4 and 3.6 in. wg.

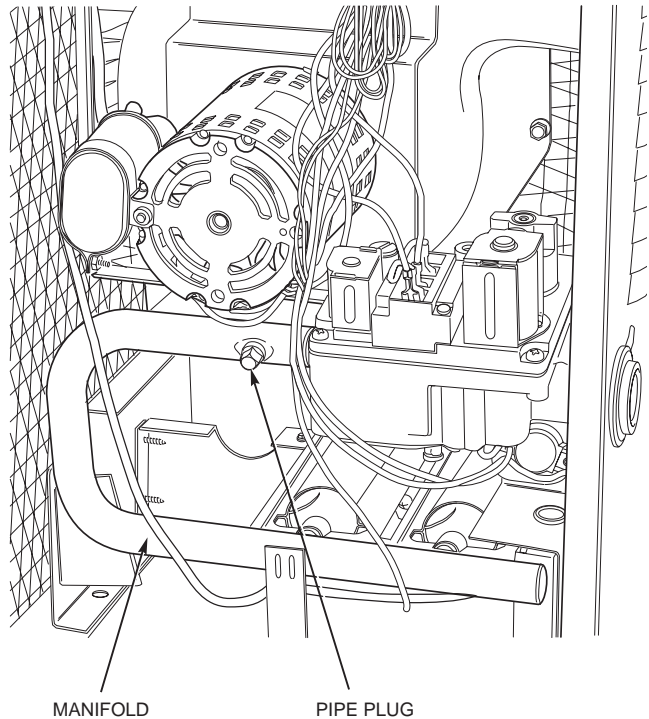

**Fig. 24 — Burner Assembly**

**⚠ WARNING**

Unsafe operation of the unit may result if manifold pressure is outside this range. Personal injury or unit damage may result.

3. Replace cover screw cap on gas valve.
4. Turn off gas supply to unit. Remove manometer from pressure tap and replace pipe plug on gas valve. Turn on gas to unit and check for leaks.



**Measure Manifold Pressure (Propane Units)** — The main burner orifices on a propane gas unit are sized for the unit rated input when the manifold pressure reading matches the level specified in Table 5.

Proceed as follows to adjust gas input on a propane gas unit:

1. Turn off gas to unit.
2. Remove pipe plug on manifold (see Fig. 24), then connect manometer at this point.
3. Turn on gas to unit.
4. Remove cover screw over regulator adjustment screw on gas valve.
5. Adjust regulator adjustment screw to the correct manifold pressure, as specified in Table 5. Turn adjusting screw clockwise to increase manifold pressure, or turn adjusting screw counterclockwise to decrease manifold pressure.
6. Replace cover screw.
7. Turn off gas to unit. Remove manometer from pressure tap. Replace pipe plug on gas valve, then turn on gas to unit. Check for leaks.

**CHECK BURNER FLAME** — With burner access panel removed, observe the unit heating operation. Watch the burner flames to see if they are light blue and soft in appearance, and that the flames are approximately the same for each burner. Propane will have blue flame with yellow tips. See Fig. 25. Refer to Maintenance section for information on burner removal.

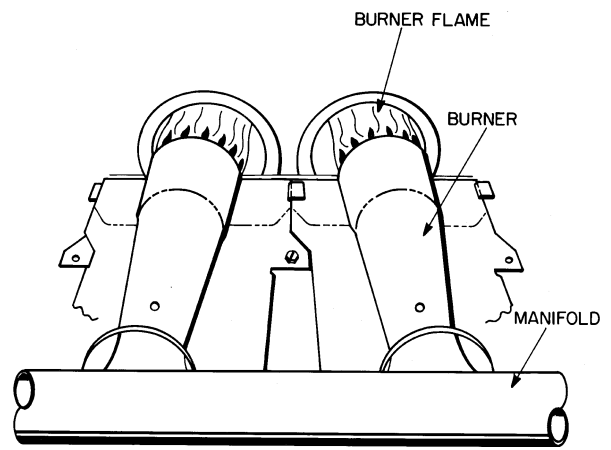

**Fig. 25 — Monoport Burners**

**AIRFLOW AND TEMPERATURE RISE** — The heating section for each size unit is designed and approved for heating operation within the temperature-rise range stamped on the unit rating plate.

Table 6 shows the approved temperature-rise range for each heating input, and the air delivery cfm at various temperature rises. The heating operation airflow must produce a temperature rise that falls within the approved range.

Refer to Evaporator Airflow and Airflow Adjustments section on page 35 to adjust heating airflow when required.

**Table 6 — Air Delivery (Cfm) at Indicated Temperature Rise and Rated Heating Input**

HEATING INPUT (Btuh)	TEMPERATURE RISE °F														
	20	25	30	35	40	45	50	55	60	65	70	75	80	85	90
40,000	1389	1111	926	794	694	617	556	—	—	—	—	—	—	—	—
56,000	2083	1667	1389	1190	1042	926	833	758	—	—	—	—	—	—	—
80,000	2778	2222	1852	1587	1389	1235	1111	1010	926	855	794	—	—	—	—
95,000	3472	2778	2315	1984	1736	1543	1389	1263	1157	1068	992	926	868	—	—
120,000	4167	3333	2778	2381	2083	1852	1667	1515	1389	1282	1190	1111	1042	980	926
136,000	5037	4029	3358	2878	2518	2238	2014	1831	1679	1549	1439	1343	1259	1185	1119

NOTE: Dashed areas do not fall within the approved temperature rise range of the unit.

HEATING SEQUENCE OF OPERATION — See Fig. 26-33 and unit wiring label.

On a call for heating, terminal “W” of the thermostat is energized, starting the induced-draft motor. When the hall-effect sensor on the induced-draft motor senses that it has reached the required speed, the burner sequence begins. This function is performed by the integrated gas control (IGC). The evaporator-fan motor is energized 45 seconds after flame is established. When the thermostat is satisfied and “W” is deenergized, the burners stop firing and the evaporator-fan motor shuts off after a 45-second time-off delay.

A LED (light-emitting diode) indicator is provided on the control board to monitor operation. The control board is located by removing the burner access panel. During normal operation, the LED is continuously on. See Table 7 for error codes.

**Table 7 — LED Indications**

ERROR CODE	LED INDICATION
Normal Operation	On
Hardware Failure	Off
Fan On/Off Delay Modified	1 Flash
Limit Switch Fault	2 Flashes
Flame Sense Fault	3 Flashes
Four Consecutive Limit Switch Faults	4 Flashes
Ignition Lockout Fault	5 Flashes
Induced-Draft Motor Fault	6 Flashes
Rollout Switch Fault	7 Flashes
Internal Control Fault	8 Flashes

**NOTES:**

1. There is a 3-second pause between error code displays.
2. If more than one error code exists, all applicable error codes will be displayed in numerical sequence.
3. This chart is on the wiring diagram located inside the burner access panel.

**LIMIT SWITCHES** — Normally-closed limit switch (LS) completes the control circuit through the thermostat R circuit. Should the leaving-air temperature rise above the maximum allowable temperature, the limit switch opens and the R control circuit “breaks.” Any interruption in the R control circuit instantly closes the gas valve and stops gas flow to the burners and pilot. The blower motor continues to run until LS resets.

When the air temperature at the limit switch drops to the low-temperature setting of the limit switch, the switch closes and completes the R control circuit. The electric-spark ignition system cycles and the unit returns to normal heating operation.

**AUXILIARY LIMIT SWITCH — ROLLOUT** — The function of the switch is to close the main gas valve in the event of flame rollout. The switch is located above the main burners. When the temperature at the auxiliary switch reaches the maximum allowable temperature, the R control circuit trips, closing the gas valve and stopping gas flow to the burners. The indoor (evaporator) fan motor (IFM) and induced draft motor continue to run until switch is reset.

## Start Up Cooling Section and Make Adjustments

### ⚠ CAUTION

- Complete the required procedures given in the Pre-Start-Up section on page 22 before starting the unit.
- Do not jumper any safety devices when operating the unit.
- Do not operate the compressor when the outdoor temperature is below 40 F (unless accessory low-ambient kit is installed).
- Do not rapid-cycle the compressor. Allow 5 minutes between “on” cycles to prevent compressor damage.

**CHECKING COOLING CONTROL OPERATION** — Start and check the unit for proper cooling control operation as follows:

1. Place room thermostat SYSTEM switch in OFF position. Observe that blower motor starts when FAN switch is placed in ON position and shuts down when FAN switch is placed in AUTO. position.
2. Place SYSTEM switch in COOL position and FAN switch in AUTO. position. Set cooling control below room temperature. Observe that compressor, condenser fan, and evaporator blower motors start. Observe that cooling cycle shuts down when control setting is satisfied. The evaporator fan will continue to run for 30 seconds.
3. When using an auto.-changeover room thermostat, place both SYSTEM and FAN switches in AUTO. positions. Observe that unit operates in heating mode when temperature control is set to “call for heating” (above room temperature) and operates in cooling mode when temperature control is set to “call for cooling” (below room temperature).

**IMPORTANT:** Three-phase, scroll compressor units (48SS048,060 and 48SX036-060) are direction-oriented. These units must be checked to ensure proper compressor 3-phase power lead orientation. If not corrected within 5 minutes, the internal protector will shut off the compressor. The 3-phase power leads to the unit must be reversed to correct rotation. When turning backwards, scroll compressors emit elevated noise levels, and the difference between compressor suction and discharge pressures may be dramatically lower than normal.

(Text continued on page 35.)

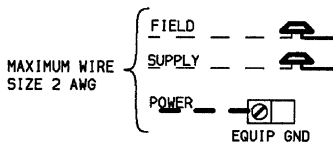
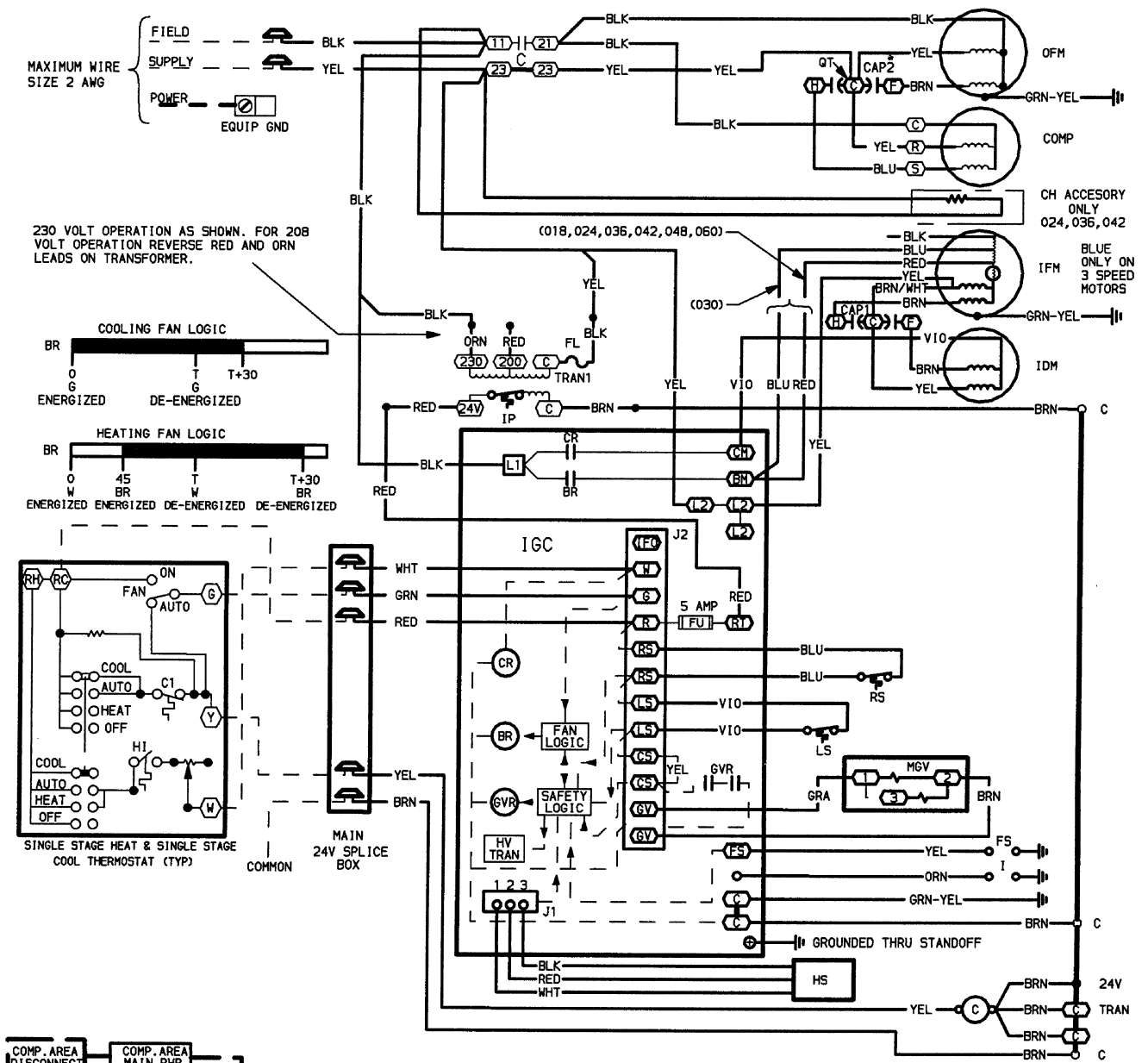

230 VOLT OPERATION AS SHOWN. FOR 208 VOLT OPERATION REVERSE RED AND ORN LEADS ON TRANSFORMER.

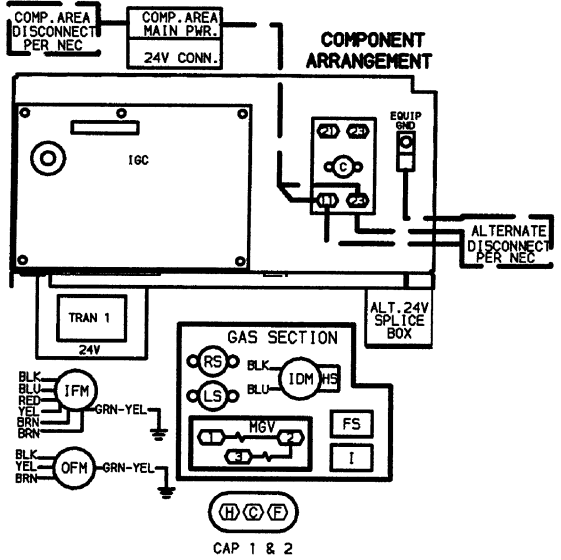
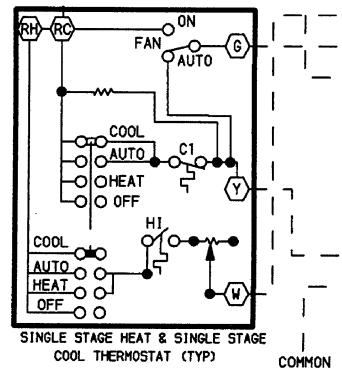
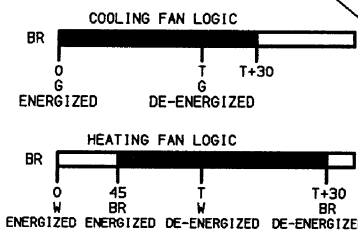

LEGEND	
AWG	American Wire Gage
BR	Blower Relay
C	Contact
CAP	Capacitor
CH	Crankcase Heater
COMP	Compressor Motor
CR	Combustion Relay
EQUIP	Equipment
FL	Fuse Link
FS	Flame Sensor
FU	Fuse
GND	Ground
GVR	Gas Valve Relay
HS	Hall Effect Sensor
HV TRAN	High-Voltage Transformer
I	Ignitor
IDM	Induced-Draft Motor
IFM	Indoor-Fan Motor
IGC	Integrated Gas Control
IP	Internal Protector
LS	Limit Switch
MGV	Main Gas Valve
NEC	National Electrical Code
OFM	Outdoor-Fan Motor
PWR	Power
QT	Quadruple Terminal
RS	Rollout Switch
TRAN	Transformer
	Field Splice
	Terminal (Marked)
	Terminal (Unmarked)
	Splice
	Splice (Marked)
	Factory Wiring
	Field Control Wiring
	Field Power Wiring
	Accessory or Optional Wiring
	To Indicate Common Potential Only, Not to Represent Wiring

- NOTES:
1. If any of the original wire furnished must be replaced, it must be replaced with type 90 C wire or its equivalent.
  2. Use copper conductors only.

Fig. 26 — 208/230-1-60 Wiring Diagram, Units 48SS018-060

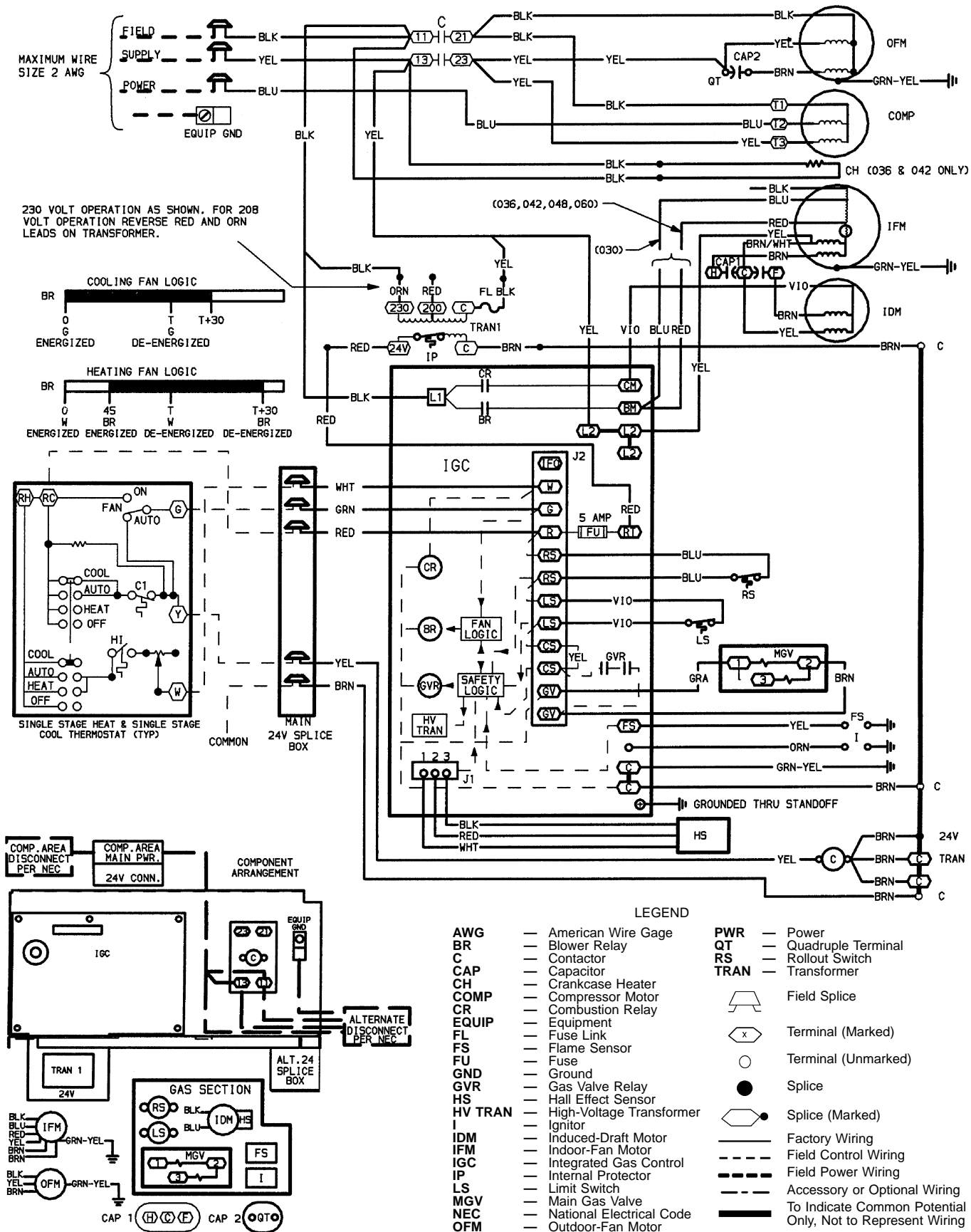

- NOTES:
1. If any of the original wire furnished must be replaced, it must be replaced with type 90 C wire or its equivalent.
  2. Use copper conductors only.

Fig. 27 — 208/230-3-60 Wiring Diagram, Units 48SS030-060

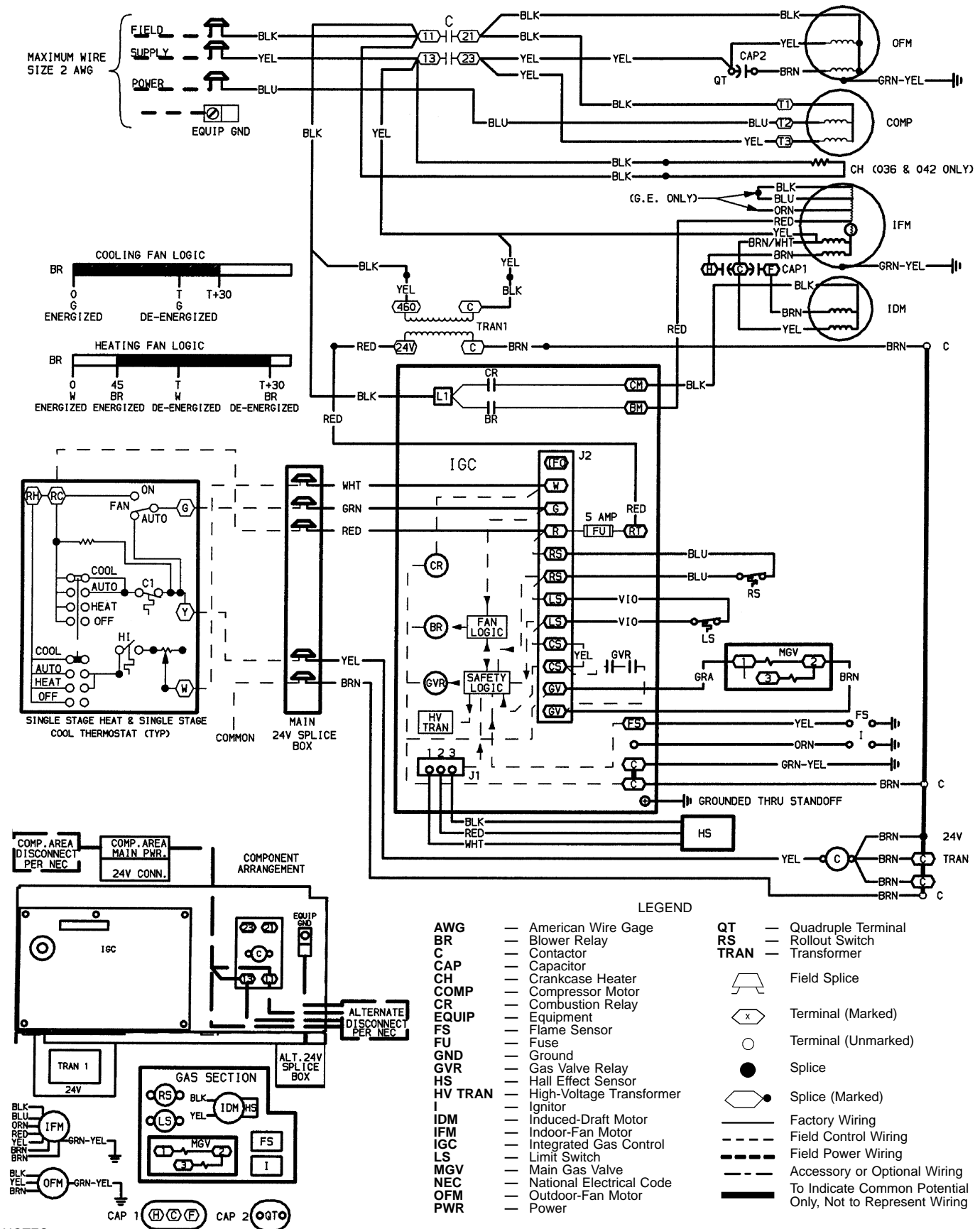

NOTES:  
 1. If any of the original wire furnished must be replaced, it must be replaced with type 90 C wire or its equivalent.  
 2. Use copper conductors only.

Fig. 28 — 460-3-60 Wiring Diagram, Units 48SS036-060

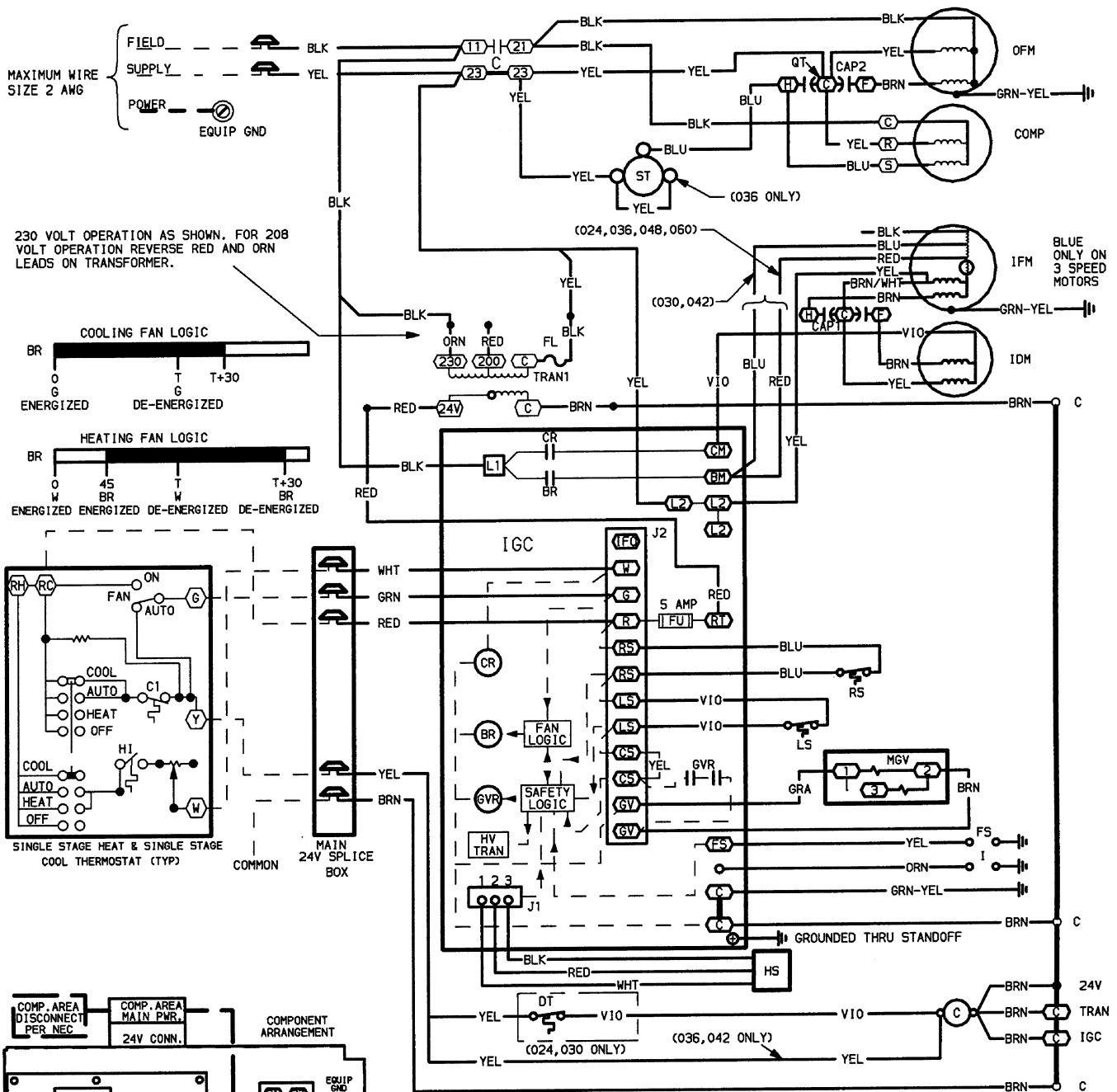

- NOTES:
1. If any of the original wire furnished must be replaced, it must be replaced with type 90 C wire or its equivalent.
  2. Use copper conductors only.

Fig. 29 — 208/230-1-60 Wiring Diagram, Units 48SX024-042

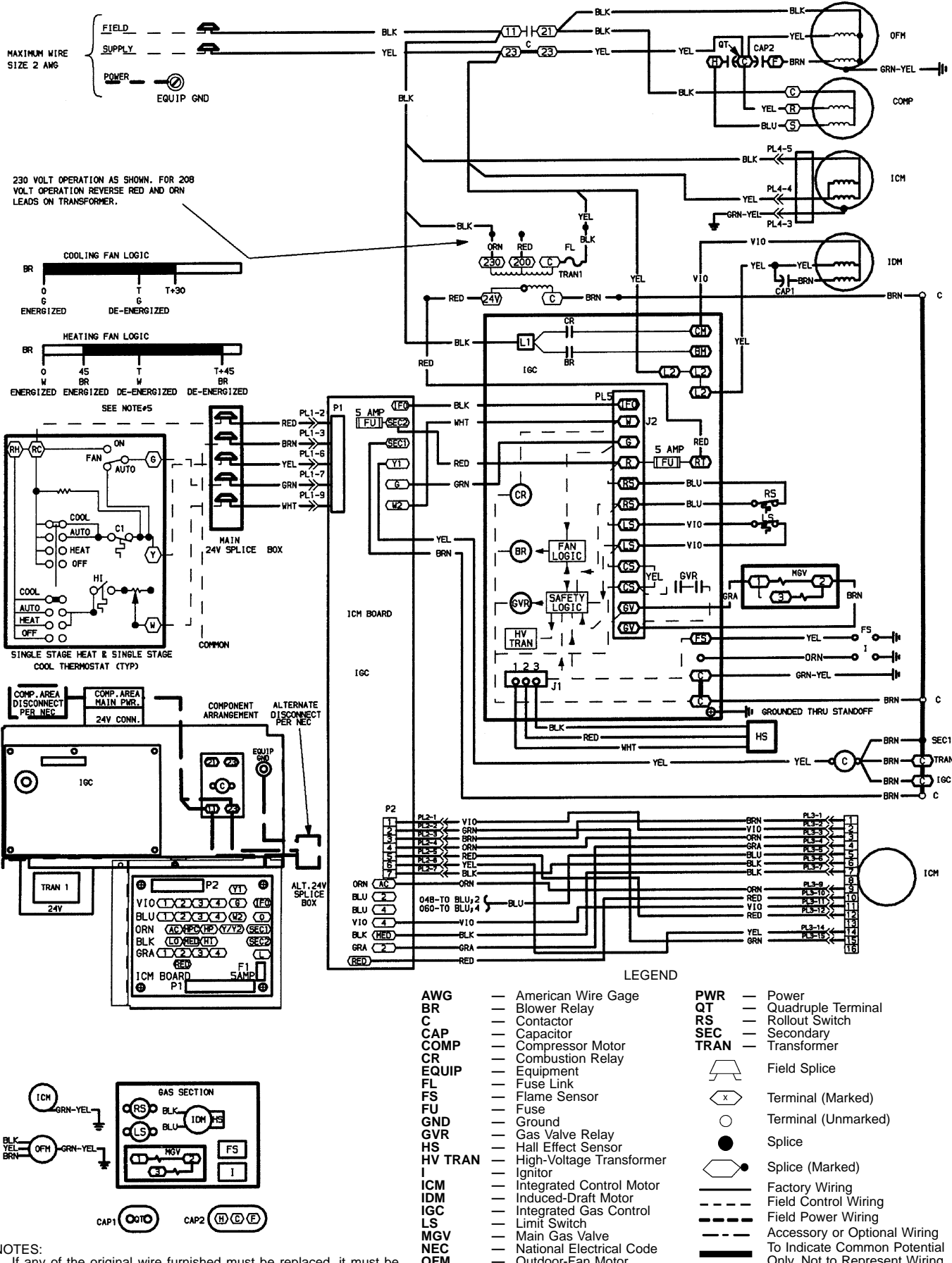

**NOTES:**

1. If any of the original wire furnished must be replaced, it must be replaced with type 90 C wire or its equivalent.
2. Use copper conductors only.

**Fig. 30 — 208/230-1-60 Wiring Diagram, Units 48SX048,060**

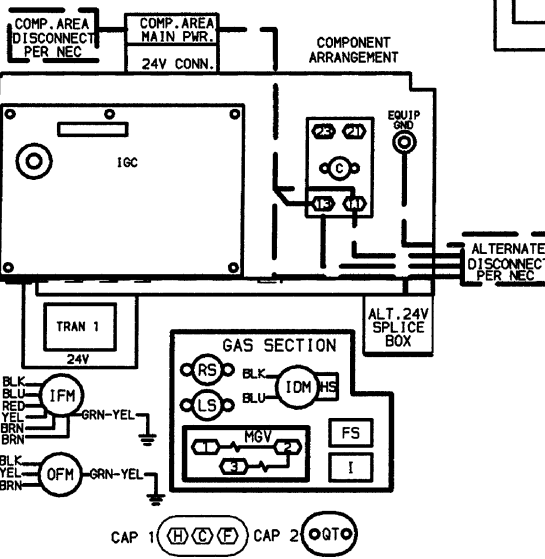
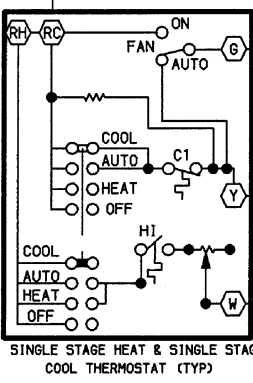
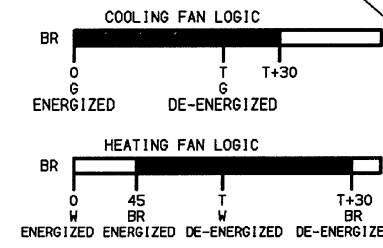
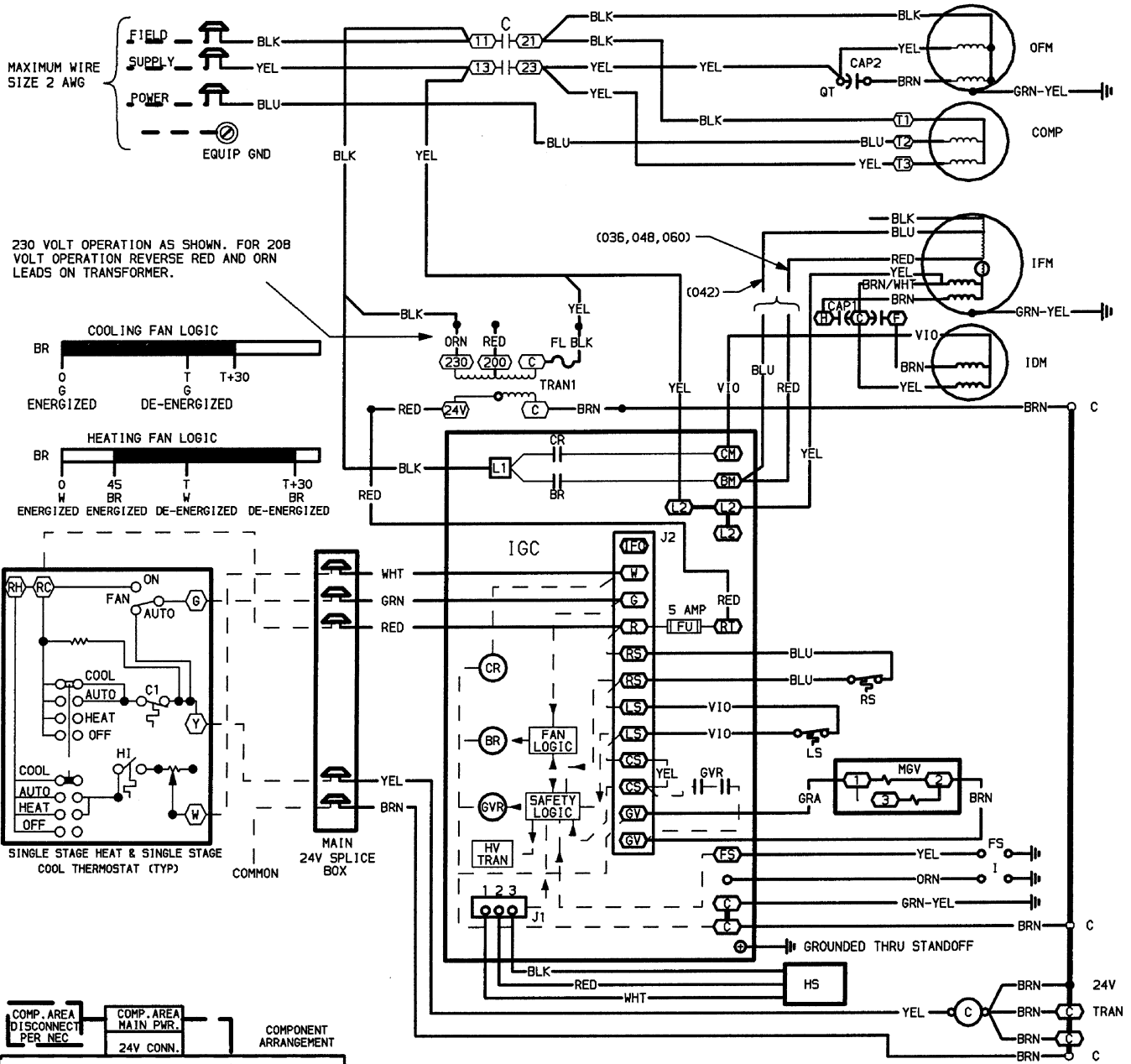

**LEGEND**

AWG	— American Wire Gage	QT	— Quadruple Terminal
BR	— Blower Relay	RS	— Rollout Switch
C	— Contactor	TRAN	— Transformer
CAP	— Capacitor		
COMP	— Compressor Motor		
CR	— Combustion Relay		
EQUIP	— Equipment		
FL	— Fuse Link		
FS	— Flame Sensor		
FU	— Fuse		
GND	— Ground		
GVR	— Gas Valve Relay		
HS	— Hall Effect Sensor		
HV TRAN	— High-Voltage Transformer		
I	— Ignitor		
IDM	— Induced-Draft Motor		
IFM	— Indoor-Fan Motor		
IGC	— Integrated Gas Control		
LS	— Limit Switch		
MGV	— Main Gas Valve		
NEC	— National Electrical Code		
OFM	— Outdoor-Fan Motor		
PWR	— Power		

	Field Splice
	Terminal (Marked)
	Terminal (Unmarked)
	Splice
	Splice (Marked)
	Factory Wiring
	Field Control Wiring
	Field Power Wiring
	Accessory or Optional Wiring
	To Indicate Common Potential Only, Not to Represent Wiring

**NOTES:**  
 1. If any of the original wire furnished must be replaced, it must be replaced with type 90 C wire or its equivalent.  
 2. Use copper conductors only.

**Fig. 31 — 208/230-3-60 Wiring Diagram, Units 48SX036-042**





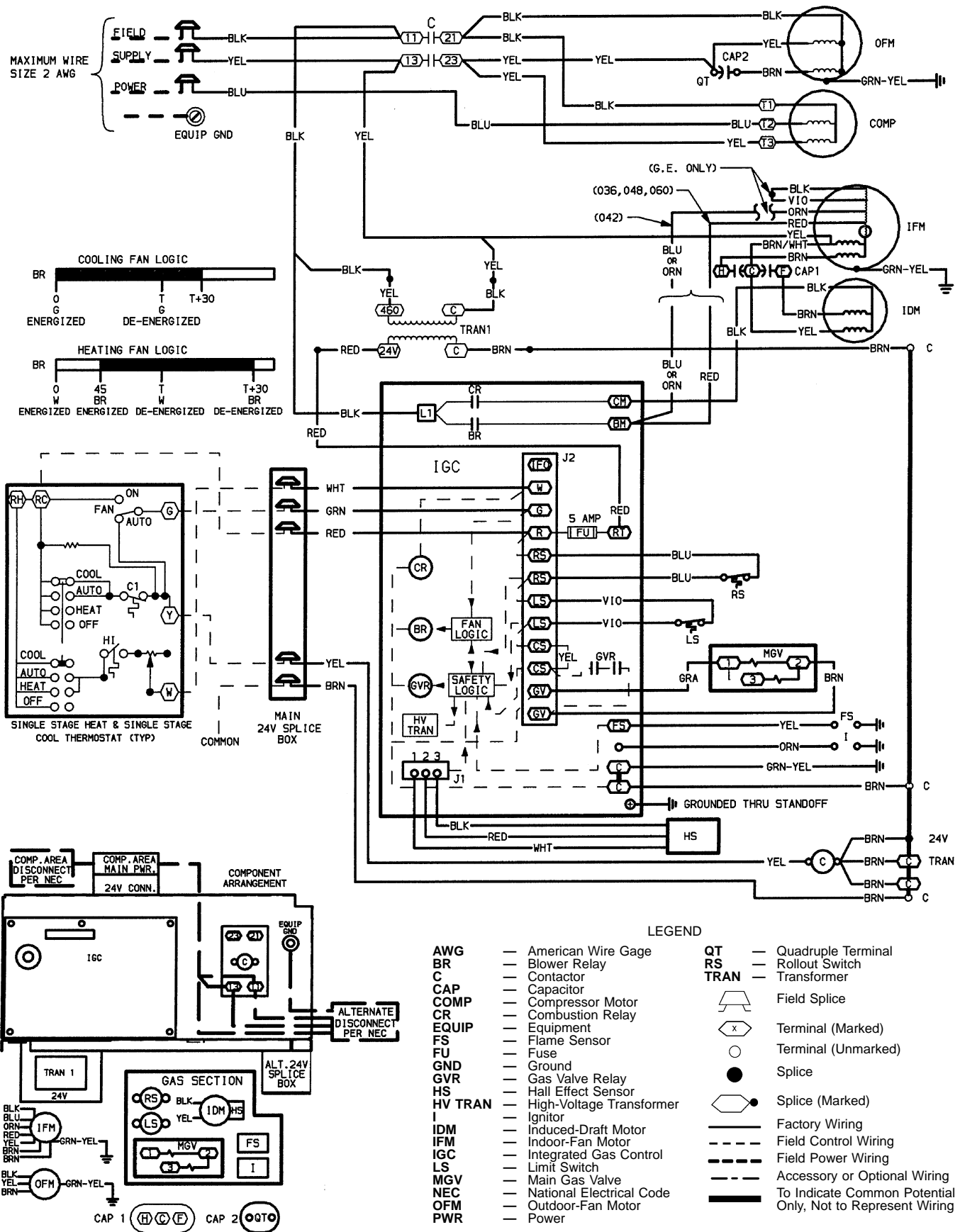

- NOTES:
1. If any of the original wire furnished was replaced, it must be replaced with type 90 C wire or its equivalent.
  2. Use copper conductors only.

Fig. 33 — 460-3-60 Wiring Diagram, Units 48SX036-048

## CHECKING AND ADJUSTING REFRIGERANT CHARGE

— The refrigerant system is fully charged with R-22 refrigerant, tested, and factory-sealed.

NOTE: Adjustment of the refrigerant charge is not required unless the unit is suspected of not having the proper R-22 charge.

A superheat charging label is attached to the inside of the compressor access door. The label includes a “Superheat Charging Table” and a “Required Suction-Tube (F) Temperature” chart.

An accurate superheat, thermocouple-, or thermistor-type thermometer, a sling psychrometer, and a gage manifold are required when using the superheat charging method for evaluating the unit charge. *Do not use mercury or small dial-type thermometers because they are not adequate for this type of measurement.*

### ⚠ CAUTION

When evaluating the refrigerant charge, an indicated adjustment to the specified factory charge must always be very minimal. If a substantial adjustment is indicated, an abnormal condition exists somewhere in the cooling system, such as insufficient airflow across either coil or both coils.

Proceed as follows:

1. Remove caps from low- and high-pressure service fittings.
2. Using hoses with valve core depressors, attach low- and high-pressure gage hoses to low- and high-pressure service fittings, respectively.
3. Start unit in cooling mode and let unit run until system pressures stabilize.
4. Measure and record the following:
  - a. Outdoor ambient-air temperature (F db).
  - b. Evaporator inlet-air temperature (F wb).
  - c. Suction-tube temperature (F) at low-side service fitting.
  - d. Suction (low-side) pressure (psig).
5. Using “Superheat Charging Table,” compare outdoor-air temperature (F db) with evaporator inlet-air temperature (F wb) to determine desired system operating superheat temperature. See Tables 8A-8H and 9A-9F.
6. Using “Required Suction-Tube (F) Temperature” table, compare desired superheat temperature with suction (low-side) operating pressure (psig) to determine proper suction-tube temperature. See Table 10.
7. Compare actual suction-tube temperature with proper suction-tube temperature. Using a tolerance of  $\pm 3^\circ\text{F}$ , add refrigerant if actual temperature is more than  $3^\circ\text{F}$  higher than proper suction-tube temperature, or remove refrigerant if actual temperature is more than  $3^\circ\text{F}$  lower than required suction-tube temperature.

NOTE: If the problem causing the inaccurate readings is a refrigerant leak, refer to Check for Refrigerant Leaks section on page 23.

## EVAPORATOR AIRFLOW AND AIRFLOW ADJUSTMENTS

### ⚠ CAUTION

For cooling operation, the recommended airflow is 350 to 450 cfm for each 12,000 Btuh of rated cooling capacity. For heating operation, the airflow must produce a temperature rise that falls within the range stamped on the unit rating plate.

Table 6 shows the temperature rise at various airflow rates. Tables 11-14 show both heating and cooling airflows at various external static pressures. See Tables 15 and 16 for ICM (Integrated Control Motor) units air delivery. Refer to these tables to determine the airflow for the system being installed. See Table 17 for wet coil pressure drop.

NOTE: Be sure that all supply- and return-air grilles are open, free from obstructions, and adjusted properly.

### ⚠ WARNING

Shut off gas supply *then* disconnect electrical power to the unit before changing blower speed. Electrical shock can cause personal injury or death.

Airflow can be changed by changing the lead connections of the blower motor.

Unit 48SS two- or 3-speed motors (except size 030) are factory wired for low speed operation. Unit 48SS030 is factory wired for medium speed. Units 48SX024,036, and 048 (460 v) two- or 3-speed motors are factory wired for low speed; units 48SX030 and 042 are factory wired for medium speed.

For 208/230-v and A.O. Smith 460-v Blower Motors — The motor leads are color-coded as follows:

3-SPEED	2-SPEED
black = high speed	black = high speed
blue = medium speed	red = low speed
red = low speed	

To change the speed of the blower motor, remove the fan motor speed leg lead from the blower relay (BR). This wire is attached to terminal BM for single-phase and 3-phase units. To change the speed, remove and replace with lead for desired blower motor speed. *Insulate the removed lead to avoid contact with chassis parts.*

For 460-v GE Motors — The motor leads are color coded as follows:

3-SPEED	2-SPEED
black = high	black = high
blue = jumper	blue = jumper
orange = medium	red = low
red = low	

To change the speed of the blower motor, remove fan motor speed lead from the blower relay (BR) and replace with the lead for the desired blower motor speed. The motor speed lead is attached to terminal BM. *Insulate removed lead end to avoid contact with chassis parts.* On 3-speed motors only, connect orange lead to terminal BM of BR. To select high speed on 460-v GE motors, separate the black (female QC) from the blue lead (male QC) and connect the black lead to the BR. *Insulate the blue lead to avoid contact with any chassis parts.*

**For Integrated Control Motors (ICM)** — To configure the 48SX unit, move the 5 Easy Select board wires to the terminals which control the airflow. Refer to the Easy Select interface board (Fig. 22) located next to the terminals and to Fig. 30 and 32.

Perform the following steps for basic system configuration.

**AUX HEAT RANGE (VIO)** — The airflow for unit 48SX is preset at the factory. The airflow selection must not be set at a setting lower than the default. Refer to Table 15 for airflow and gas heat input for terminals 1-4.

**AC/HP SIZE (BLU)** — The preset factory default selection for AC/HP SIZE (air conditioner/heat pump) is set to 400 cfm/ton. The selection pins are configured for 350 cfm/ton and 400 cfm/ton.

**TYPE (ORN)** — The TYPE is a preset factory default selection. The preset factory default setting is AC for the 48SX units. Default setting should not be altered.

**AC/HP CFM ADJUST (BLK)** — The preset factory default selection is MED. Selections HI and LO will adjust the airflow supplied for all operational modes (see following table).

The selection options allow installer to adjust airflow to meet such individual needs as noise and static compensation, etc.

MODE	FAN ONLY	COOLING	HEATING
LO - Adjust	-15%	-10%	-10%
HI - Adjust	15%	10%	10%

**AC/HP TIME DELAY (GRY)** — Four motor operation delay options are provided to customize system operation. See table below:

OPTION	TERMINAL	DESCRIPTION
30-Sec On/60-Sec Off Delay Profile	1	Used when it is desirable to allow system coils time to heat up or cool down prior to airflow. Enhances system efficiency.
No Delay Option	2	Preset factory default setting for 48SX. Used for servicing or when other components are used to perform a delay function (e.g., integrated gas control).
30-Sec Off Delay	3	Enhances system efficiency.
45-Sec Off Delay	4	Enhances system efficiency.

**Table 8A — Superheat Charging Table, 48SS018**

TEMP (F) AIR ENT COND		EVAP AIR — CFM											
		600											
		Evap Air — Ewb (F)											
		54	56	58	60	62	64	66	68	70	72	74	76
65	SPH	17.3	18.5	19.6	20.8	24.2	27.7	28.5	29.3	29.3	29.3	29.3	29.3
70	SPH	13.8	14.9	16.1	17.3	20.7	24.1	25.7	27.3	27.3	27.3	27.3	27.3
75	SPH	10.2	11.4	12.5	13.7	17.1	20.6	22.9	25.2	25.2	25.2	25.2	25.2
80	SPH	8.2	8.8	9.5	10.2	13.6	17.0	20.1	23.1	23.9	24.1	25.4	26.1
85	SPH	6.1	6.2	6.5	6.6	10.0	13.5	17.3	21.1	22.6	24.1	25.6	27.1
90	SPH	*	*	*	5.0	8.1	11.4	15.2	19.0	20.5	22.0	23.5	25.0
95	SPH	*	*	*	*	6.2	9.4	13.2	17.0	18.5	20.0	21.5	23.0
100	SPH	*	*	*	*	*	7.3	11.1	14.9	17.2	19.5	21.7	24.0
105	SPH	*	*	*	*	*	5.3	9.1	12.9	15.9	18.9	21.9	24.9
110	SPH	*	*	*	*	*	*	6.7	10.8	13.8	16.8	19.8	22.8
115	SPH	*	*	*	*	*	*	*	8.8	11.8	14.8	17.8	20.8

LEGEND

Ewb — Entering Wet Bulb  
SPH — Superheat at Compressor (F)

\*Do not attempt to charge system under these conditions — refrigerant slugging may occur.

**Table 8B — Superheat Charging Table, 48SS024**

TEMP (F) AIR ENT COND		EVAP AIR — CFM											
		800											
		Evap Air — Ewb (F)											
		54	56	58	60	62	64	66	68	70	72	74	76
65	SPH	18.2	19.0	19.9	20.7	22.5	24.2	25.1	25.9	26.6	27.2	27.9	28.6
70	SPH	17.1	17.6	18.1	18.6	20.4	22.1	23.0	23.9	24.9	26.0	27.1	28.1
75	SPH	16.0	16.2	16.4	16.6	18.3	20.1	21.0	21.8	23.3	24.8	26.2	27.7
80	SPH	14.8	14.7	14.6	14.5	16.3	18.0	19.7	21.3	22.4	23.5	24.6	25.8
85	SPH	13.7	13.3	12.9	12.5	14.3	16.0	18.4	20.7	21.5	22.3	23.1	23.8
90	SPH	11.1	10.9	10.7	10.4	12.2	13.9	16.3	18.7	19.9	21.0	22.2	23.4
95	SPH	8.5	8.4	8.4	8.4	10.1	11.9	14.3	16.6	18.2	19.8	21.4	23.0
100	SPH	7.3	7.5	7.7	7.9	8.9	9.9	12.2	14.6	16.6	18.6	20.6	22.6
105	SPH	6.2	6.6	6.9	7.3	7.6	7.8	10.2	12.5	14.9	17.3	19.7	22.1
110	SPH	*	*	*	5.3	5.5	5.8	8.1	10.5	13.3	16.1	18.9	21.7
115	SPH	*	*	*	*	*	*	6.1	8.4	11.6	14.9	18.1	21.3

LEGEND

Ewb — Entering Wet Bulb  
SPH — Superheat at Compressor (F)

\*Do not attempt to charge system under these conditions — refrigerant slugging may occur.

**Table 8C — Superheat Charging Table, 48SS030**

TEMP (F) AIR ENT COND		EVAP AIR — CFM											
		1000											
		Evap Air — Ewb (F)											
		54	56	58	60	62	64	66	68	70	72	74	76
65	SPH	14.2	15.1	16.1	17.1	19.2	21.3	23.3	24.7	25.9	27.2	27.8	28.5
70	SPH	13.6	14.1	14.6	15.0	17.1	19.2	21.3	22.8	24.2	25.7	26.3	26.9
75	SPH	13.0	13.0	13.0	13.0	15.1	17.2	19.2	20.9	22.6	24.2	24.8	25.4
80	SPH	10.9	11.0	11.0	10.9	13.6	16.1	18.7	20.1	21.4	22.7	23.6	24.4
85	SPH	8.9	8.9	8.9	8.9	12.0	15.1	18.2	19.2	20.2	21.2	22.4	23.5
90	SPH	8.3	8.4	8.4	8.3	10.9	13.6	16.2	17.7	19.2	20.8	21.6	22.5
95	SPH	7.8	7.8	7.8	7.8	9.9	12.0	14.1	16.1	18.2	20.2	20.9	21.7
100	SPH	7.3	7.3	7.3	7.3	9.3	11.4	13.6	15.6	17.6	19.7	20.2	20.7
105	SPH	6.7	6.7	6.7	6.7	8.8	10.9	13.0	15.0	17.1	19.1	19.4	19.8
110	SPH	*	*	*	*	6.7	8.9	10.9	13.0	15.0	17.1	18.0	18.9
115	SPH	*	*	*	*	*	6.8	8.9	10.9	13.0	15.0	16.5	18.0

LEGEND

Ewb — Entering Wet Bulb  
SPH — Superheat at Compressor (F)

\*Do not attempt to charge system under these conditions — refrigerant slugging may occur.

**Table 8D — Superheat Charging Table, 48SS036**

TEMP (F) AIR ENT COND		EVAP AIR — CFM											
		1200											
		Evap Air — Ewb (F)											
		54	56	58	60	62	64	66	68	70	72	74	76
65	SPH	8.4	8.4	8.4	8.4	12.5	16.7	18.7	20.7	22.0	23.4	24.8	26.1
70	SPH	5.0	5.0	5.0	5.0	9.0	13.1	15.9	18.6	20.0	21.3	22.7	24.0
75	SPH	*	*	*	*	5.4	9.6	13.1	16.6	17.9	19.3	20.6	22.0
80	SPH	*	*	*	*	*	6.0	10.3	14.5	15.9	17.3	18.6	20.0
85	SPH	*	*	*	*	*	*	7.5	12.5	13.9	15.2	16.5	17.9
90	SPH	*	*	*	*	*	*	5.4	10.4	12.5	14.6	16.8	18.8
95	SPH	*	*	*	*	*	*	*	8.4	11.3	14.1	17.0	19.8
100	SPH	*	*	*	*	*	*	*	6.4	10.0	13.5	17.1	20.7
105	SPH	*	*	*	*	*	*	*	*	8.7	13.0	17.3	21.7
110	SPH	*	*	*	*	*	*	*	*	9.3	12.4	15.6	18.7
115	SPH	*	*	*	*	*	*	*	*	10.0	11.9	13.8	15.8

LEGEND

Ewb — Entering Wet Bulb  
SPH — Superheat at Compressor (F)

\*Do not attempt to charge system under these conditions — refrigerant slugging may occur.

**Table 8E — Superheat Charging Table, 48SS042**

TEMP (F) AIR ENT COND		EVAP AIR — CFM											
		1400											
		Evap Air — Ewb (F)											
		54	56	58	60	62	64	66	68	70	72	74	76
65	SPH	11.0	11.0	11.0	14.0	17.0	20.0	22.0	24.0	26.0	26.0	27.7	28.6
70	SPH	7.5	7.5	7.5	10.4	13.4	16.4	18.9	21.4	24.0	25.0	26.1	27.1
75	SPH	*	*	*	6.9	9.9	12.9	15.9	18.9	21.9	23.2	24.4	25.7
80	SPH	*	*	*	5.9	8.4	10.8	13.8	16.8	19.8	21.3	22.8	24.9
85	SPH	*	*	*	5.0	6.9	8.8	11.8	14.8	17.8	19.5	21.1	22.8
90	SPH	*	*	*	*	6.0	6.8	10.2	13.7	17.3	18.6	20.0	21.4
95	SPH	*	*	*	*	*	5.0	8.7	12.7	16.7	17.8	18.9	20.0
100	SPH	*	*	*	*	*	*	6.5	10.5	14.6	16.4	18.2	20.0
105	SPH	*	*	*	*	*	*	*	8.4	12.6	15.1	17.6	20.0
110	SPH	*	*	*	*	*	*	*	8.0	12.0	14.2	16.4	18.6
115	SPH	*	*	*	*	*	*	*	7.7	11.5	13.4	15.3	17.2

LEGEND

Ewb — Entering Wet Bulb  
SPH — Superheat at Compressor (F)

\*Do not attempt to charge system under these conditions — refrigerant slugging may occur.

**Table 8F — Superheat Charging Table, 48SS048 (Carrier Scroll Compressor)**

TEMP (F) AIR ENT COND		EVAP AIR — CFM											
		1600											
		Evap Air — Ewb (F)											
		54	56	58	60	62	64	66	68	70	72	74	76
65	SPH	15.5	15.5	15.6	15.6	17.6	19.6	21.6	22.8	24.0	25.2	25.2	25.3
70	SPH	11.7	11.8	11.8	11.8	13.9	16.0	18.0	20.1	22.2	24.3	24.3	24.3
75	SPH	8.0	8.0	8.0	8.0	10.2	12.3	14.5	17.4	20.4	23.3	23.3	23.3
80	SPH	6.0	6.0	6.0	6.0	8.7	11.3	13.9	16.3	18.6	20.9	21.5	22.0
85	SPH	*	*	*	*	7.2	10.3	13.4	15.1	16.8	18.5	19.7	20.8
90	SPH	*	*	*	*	5.6	7.7	9.9	12.4	15.0	17.6	18.7	19.8
95	SPH	*	*	*	*	*	5.2	6.3	9.8	13.2	16.7	17.7	18.8
100	SPH	*	*	*	*	*	*	5.8	9.1	12.5	15.8	17.1	18.4
105	SPH	*	*	*	*	*	*	5.2	8.4	11.7	14.9	16.5	18.1
110	SPH	*	*	*	*	*	*	6.2	8.8	11.4	14.0	15.9	17.8
115	SPH	*	*	*	*	*	*	7.1	9.1	11.1	13.1	15.3	17.5

LEGEND

Ewb — Entering Wet Bulb  
SPH — Superheat at Compressor (F)

\*Do not attempt to charge system under these conditions — refrigerant slugging may occur.

**Table 8G — Superheat Charging Table, 48SS048 (Copeland Scroll Compressor)**

TEMP (F) AIR ENT COND		EVAP AIR — CFM											
		1600											
		Evap Air — Ewb (F)											
		54	56	58	60	62	64	66	68	70	72	74	76
65	SPH	19.0	19.0	19.0	19.0	21.7	24.3	26.0	27.7	27.9	28.2	28.4	28.6
70	SPH	15.4	15.4	15.4	15.4	18.1	20.8	22.5	24.1	25.1	26.1	27.1	28.1
75	SPH	11.9	11.9	11.9	11.9	14.6	17.2	18.9	20.6	22.3	24.0	25.8	27.5
80	SPH	8.4	8.4	8.4	8.4	11.0	13.7	15.4	17.0	19.5	22.0	24.5	27.0
85	SPH	5.0	5.0	5.0	5.0	7.5	10.1	11.8	13.5	16.7	20.0	23.2	26.4
90	SPH	*	*	*	*	*	6.6	9.0	11.4	14.7	17.9	21.1	24.4
95	SPH	*	*	*	*	*	*	6.2	9.4	12.6	15.9	19.1	22.3
100	SPH	*	*	*	*	*	*	*	7.3	10.6	13.8	17.0	20.3
105	SPH	*	*	*	*	*	*	*	5.3	8.5	11.8	15.0	18.2
110	SPH	*	*	*	*	*	*	*	*	6.9	11.2	15.5	19.8
115	SPH	*	*	*	*	*	*	*	*	5.3	10.6	16.0	21.3

LEGEND

Ewb — Entering Wet Bulb  
SPH — Superheat at Compressor (F)

\*Do not attempt to charge system under these conditions — refrigerant slugging may occur.

**Table 8H — Superheat Charging Table, 48SS060**

TEMP (F) AIR ENT COND		EVAP AIR — CFM											
		1995											
		Evap Air — Ewb (F)											
		54	56	58	60	62	64	66	68	70	72	74	76
65	SPH	20.1	20.1	20.1	20.1	20.1	20.1	22.6	25.2	25.6	26.1	26.6	27.0
70	SPH	16.5	16.5	16.5	16.5	17.3	18.0	20.6	23.1	24.0	24.8	25.6	26.5
75	SPH	13.0	13.0	13.0	13.0	14.5	16.0	18.5	21.1	22.3	23.5	24.7	25.9
80	SPH	10.9	10.9	10.9	10.9	12.4	13.9	16.5	19.0	20.6	22.2	23.8	25.4
85	SPH	8.9	8.9	8.9	8.9	10.4	11.9	14.4	17.0	18.9	20.9	22.9	24.9
90	SPH	6.9	6.9	6.9	6.9	8.4	9.9	12.4	14.9	17.3	19.6	22.0	24.3
95	SPH	5.0	5.0	5.0	5.0	6.3	7.8	10.3	12.9	15.6	18.3	21.1	23.8
100	SPH	*	*	*	*	*	5.8	8.3	10.8	13.9	17.0	20.1	23.2
105	SPH	*	*	*	*	*	*	6.2	8.8	12.3	15.7	19.2	22.7
110	SPH	*	*	*	*	*	*	*	6.7	10.6	14.4	18.3	22.2
115	SPH	*	*	*	*	*	*	*	*	8.9	13.1	17.4	21.6

LEGEND

Ewb — Entering Wet Bulb  
SPH — Superheat at Compressor (F)

\*Do not attempt to charge system under these conditions — refrigerant slugging may occur.

**Table 9A — Superheat Charging Table, 48SX024**

TEMP (F) AIR ENT COND		EVAP AIR — CFM											
		800											
		Evap Air — Ewb (F)											
		54	56	58	60	62	64	66	68	70	72	74	76
65	SPH	22.1	22.1	22.8	23.2	25.3	27.4	29.5	29.8	30.2	30.5	31.3	32.1
70	SPH	18.5	18.9	19.3	19.6	22.2	24.8	27.5	28.3	29.1	30.0	30.0	30.0
75	SPH	15.0	15.4	15.7	16.1	19.2	22.3	25.4	26.7	28.1	29.4	28.7	28.0
80	SPH	9.2	9.5	9.7	9.9	14.4	18.9	23.3	24.7	26.0	27.3	27.4	27.4
85	SPH	*	*	*	*	9.6	15.5	21.3	22.6	24.0	25.3	26.1	26.8
90	SPH	*	*	*	*	7.2	12.5	17.8	20.1	22.4	24.8	25.1	25.5
95	SPH	*	*	*	*	*	9.4	14.2	17.5	20.9	24.2	24.2	24.2
100	SPH	*	*	*	*	*	7.1	10.6	14.5	18.3	22.1	22.9	23.6
105	SPH	*	*	*	*	*	*	7.1	11.4	15.8	20.1	21.6	23.1
110	SPH	*	*	*	*	*	*	*	8.4	13.2	18.0	19.5	21.0
115	SPH	*	*	*	*	*	*	*	5.3	10.7	16.0	17.5	19.0

LEGEND \*Do not attempt to charge system under these conditions — refrigerant slugging may occur.  
**Ewb** — Entering Wet Bulb  
**SPH** — Superheat at Compressor (F)

**Table 9B — Superheat Charging Table, 48SX030**

TEMP (F) AIR ENT COND		EVAP AIR — CFM											
		1000											
		Evap Air — Ewb (F)											
		54	56	58	60	62	64	66	68	70	72	74	76
65	SPH	11.2	11.2	11.2	11.2	14.9	18.6	22.3	22.4	22.5	22.7	22.9	23.1
70	SPH	7.6	7.7	7.7	7.7	12.1	16.6	21.1	21.6	22.0	22.4	22.5	22.5
75	SPH	*	*	*	*	9.4	14.7	20.0	20.7	21.4	22.1	22.1	22.0
80	SPH	*	*	*	*	8.5	13.5	18.5	19.3	20.2	21.0	21.6	22.1
85	SPH	*	*	*	*	7.6	12.3	17.0	18.0	18.9	19.9	21.1	22.3
90	SPH	*	*	*	*	*	10.0	14.2	16.0	17.8	19.6	20.7	21.8
95	SPH	*	*	*	*	*	7.7	11.5	14.1	16.7	19.2	20.2	21.2
100	SPH	*	*	*	*	*	*	5.7	9.9	14.0	18.2	19.4	20.6
105	SPH	*	*	*	*	*	*	*	5.7	11.4	17.1	18.6	20.1
110	SPH	*	*	*	*	*	*	*	*	8.9	13.5	15.8	18.0
115	SPH	*	*	*	*	*	*	*	*	*	10.0	13.0	16.0

LEGEND \*Do not attempt to charge system under these conditions — refrigerant slugging may occur.  
**Ewb** — Entering Wet Bulb  
**SPH** — Superheat at Compressor (F)

**Table 9C — Superheat Charging Table, 48SX036**

TEMP (F) AIR ENT COND		EVAP AIR — CFM											
		1200											
		Evap Air — Ewb (F)											
		54	56	58	60	62	64	66	68	70	72	74	76
65	SPH	21.3	21.3	21.3	21.3	22.0	22.6	23.3	23.5	23.7	23.8	23.3	22.8
70	SPH	19.3	19.3	19.3	19.3	20.2	21.2	22.2	22.3	22.5	22.6	22.0	21.5
75	SPH	17.2	17.2	17.2	17.2	18.5	19.7	21.0	21.1	21.3	21.4	20.7	20.1
80	SPH	13.6	13.6	13.6	13.6	15.1	16.6	18.0	18.5	18.9	19.3	19.4	19.5
85	SPH	10.1	10.1	10.1	10.1	11.7	13.4	15.0	15.8	16.5	17.3	18.1	19.0
90	SPH	6.5	6.5	6.5	6.5	8.8	11.2	13.5	14.6	15.7	16.8	17.2	17.6
95	SPH	*	*	*	*	6.0	9.0	12.0	13.4	14.8	16.2	16.2	16.2
100	SPH	*	*	*	*	*	*	6.0	8.7	11.4	14.1	14.9	15.6
105	SPH	*	*	*	*	*	*	*	*	8.0	12.1	13.6	15.1
110	SPH	*	*	*	*	*	*	*	*	*	10.0	11.5	13.0
115	SPH	*	*	*	*	*	*	*	*	*	8.0	9.5	11.0

LEGEND \*Do not attempt to charge system under these conditions — refrigerant slugging may occur.  
**Ewb** — Entering Wet Bulb  
**SPH** — Superheat at Compressor (F)

**Table 9D — Superheat Charging Table, 48SX042**

TEMP (F) AIR ENT COND		EVAP AIR — CFM											
		1400											
		Evap Air — Ewb (F)											
		54	56	58	60	62	64	66	68	70	72	74	76
65	SPH	23.9	23.9	23.9	23.9	24.4	24.9	25.5	25.8	26.1	26.5	25.6	24.7
70	SPH	21.9	21.9	21.9	21.9	22.4	22.9	23.4	23.7	24.1	24.5	24.0	23.5
75	SPH	19.8	19.8	19.8	19.8	20.3	20.8	21.3	21.7	22.0	22.4	22.4	22.4
80	SPH	16.3	16.3	16.3	16.3	17.9	19.6	21.3	21.5	21.7	21.8	21.8	21.8
85	SPH	12.7	12.7	12.7	12.7	15.6	18.4	21.3	21.3	21.3	21.3	21.3	21.3
90	SPH	9.2	9.2	9.2	9.2	12.0	14.9	17.8	18.7	19.7	20.8	20.8	20.8
95	SPH	5.6	5.6	5.6	5.6	8.5	11.3	14.2	16.2	18.2	20.2	20.2	20.2
100	SPH	*	*	*	*	*	8.0	10.6	13.1	15.6	18.1	18.9	19.6
105	SPH	*	*	*	*	*	*	7.1	10.1	13.1	16.1	17.6	19.1
110	SPH	*	*	*	*	*	*	*	7.0	10.5	14.0	15.5	17.0
115	SPH	*	*	*	*	*	*	*	*	8.0	12.0	13.5	15.0

LEGEND

Ewb — Entering Wet Bulb  
SPH — Superheat at Compressor (F)

\*Do not attempt to charge system under these conditions — refrigerant slugging may occur.

**Table 9E — Superheat Charging Table, 48SX048**

TEMP (F) AIR ENT COND		EVAP AIR — CFM											
		1600											
		Evap Air — Ewb (F)											
		54	56	58	60	62	64	66	68	70	72	74	76
65	SPH	27.2	27.2	27.2	27.2	27.0	26.7	26.5	26.0	25.6	25.1	24.5	24.0
70	SPH	25.0	25.0	25.0	25.0	24.8	24.6	24.5	24.5	24.5	24.6	23.8	23.1
75	SPH	22.8	22.8	22.8	22.8	22.7	22.5	22.4	22.9	23.5	24.0	23.1	22.2
80	SPH	20.6	20.6	20.6	20.6	20.5	20.4	20.3	21.4	22.4	23.5	22.4	21.4
85	SPH	18.3	18.3	18.3	18.3	18.3	18.3	18.3	19.8	21.4	22.9	21.8	20.6
90	SPH	13.3	13.3	13.3	13.3	14.2	15.2	16.3	17.8	19.3	20.9	20.4	19.9
95	SPH	8.2	8.2	8.2	8.2	10.2	12.2	14.2	15.7	17.3	18.8	19.0	19.2
100	SPH	*	*	*	*	6.3	8.4	10.6	12.9	15.2	17.5	18.1	18.7
105	SPH	*	*	*	*	*	*	7.1	10.1	13.1	16.1	17.1	18.2
110	SPH	*	*	*	*	*	*	*	7.1	10.5	14.0	15.3	16.6
115	SPH	*	*	*	*	*	*	*	*	8.0	12.0	13.5	15.0

LEGEND

Ewb — Entering Wet Bulb  
SPH — Superheat at Compressor (F)

\*Do not attempt to charge system under these conditions — refrigerant slugging may occur.

**Table 9F — Superheat Charging Table, 48SX060**

TEMP (F) AIR ENT COND		EVAP AIR — CFM											
		1995											
		Evap Air — Ewb (F)											
		54	56	58	60	62	64	66	68	70	72	74	76
65	SPH	20.1	20.1	20.1	20.1	20.1	20.1	22.6	25.2	25.6	26.1	26.6	27.0
70	SPH	16.5	16.5	16.5	16.5	17.3	18.0	20.6	23.1	24.0	24.8	25.6	26.5
75	SPH	13.0	13.0	13.0	13.0	14.5	16.0	18.5	21.1	22.3	23.5	24.7	25.9
80	SPH	10.9	10.9	10.9	10.9	12.4	13.9	16.5	19.0	20.6	22.2	23.8	25.4
85	SPH	8.9	8.9	8.9	8.9	10.4	11.9	14.4	17.0	18.9	20.9	22.9	24.9
90	SPH	6.9	6.9	6.9	6.9	8.4	9.9	12.4	14.9	17.3	19.6	22.0	24.3
95	SPH	5.0	5.0	5.0	5.0	6.3	7.8	10.3	12.9	15.6	18.3	21.1	23.8
100	SPH	*	*	*	*	*	5.8	8.3	10.8	13.9	17.0	20.1	23.2
105	SPH	*	*	*	*	*	*	6.2	8.8	12.3	15.7	19.2	22.7
110	SPH	*	*	*	*	*	*	*	6.7	10.6	14.4	18.3	22.2
115	SPH	*	*	*	*	*	*	*	*	8.9	13.1	17.4	21.6

LEGEND

Ewb — Entering Wet Bulb  
SPH — Superheat at Compressor (F)

\*Do not attempt to charge system under these conditions — refrigerant slugging may occur.



**Table 10 — Required Suction-Tube Temperature (F)\***

SUPERHEAT TEMP (F)	SUCTION PRESSURE AT SERVICE PORT (psig)								
	61.5	64.2	67.1	70.0	73.0	76.0	79.2	82.4	85.7
0	35	37	39	41	43	45	47	49	51
2	37	39	41	43	45	47	49	51	53
4	39	41	43	45	47	49	51	53	55
6	41	43	45	47	49	51	53	55	57
8	43	45	47	49	51	53	55	57	59
10	45	47	49	51	53	55	57	59	61
12	47	49	51	53	55	57	59	61	63
14	49	51	53	55	57	59	61	63	65
16	51	53	55	57	59	61	63	65	67
18	53	55	57	59	61	63	65	67	69
20	55	57	59	61	63	65	67	69	71
22	57	59	61	63	65	67	69	71	73
24	59	61	63	65	67	69	71	73	75
26	61	63	65	67	69	71	73	75	77
28	63	65	67	69	71	73	75	77	79
30	65	67	69	71	73	75	77	79	81
32	67	69	71	73	75	77	79	81	83
34	69	71	73	75	77	79	81	83	85
36	71	73	75	77	79	81	83	85	87
38	73	75	77	79	81	83	85	87	89
40	75	77	79	81	83	85	87	89	91

\*Temperature at suction service valve.

**Table 11 — Dry-Coil Air Delivery\* — Horizontal Discharge at 230 and 460 V — Unit 48SS  
(Deduct 10% from Cfm and Watts for 208 V Operation)**

UNIT 48SS	MOTOR SPEED	AIR DELIVERY	EXTERNAL STATIC PRESSURE (in. wg)										
			0.0	0.1	0.2	0.3	0.4	0.5	0.6	0.7	0.8	0.9	1.0
018	Low	Watts	230	225	220	210	195	170	†	†	†	†	†
		Cfm	760	745	725	695	640	540	†	†	†	†	†
	High	Watts	†	†	†	†	270	235	200	†	†	†	†
		Cfm	†	†	†	†	850	700	450	†	†	†	†
024, 030	Low	Watts	275	275	273	269	260	257	249	†	†	†	†
		Cfm	857	835	802	782	745	717	663	†	†	†	†
	Med	Watts	371	368	360	349	345	326	319	304	293	†	†
		Cfm	1079	1063	1027	996	978	919	865	783	726	†	†
	High	Watts	514	493	476	460	443	425	401	378	344	†	†
		Cfm	1409	1383	1324	1282	1223	1156	1068	984	857	†	†
036	Low	Watts	473	447	427	418	395	367	346	337	323	†	†
		Cfm	1253	1253	1172	1130	1047	946	865	829	768	†	†
	Med	Watts	519	500	478	459	439	410	377	357	340	†	†
		Cfm	1414	1366	1287	1234	1162	1074	920	829	743	†	†
	High	Watts	667	634	609	593	564	541	506	469	436	422	†
		Cfm	1734	1639	1563	1461	1370	1292	1157	960	829	743	†
042	Low	Watts	678	635	604	580	550	520	493	455	430	†	†
		Cfm	1540	1515	1475	1430	1375	1280	1225	1128	1020	†	†
	High	Watts	†	820	785	750	700	680	649	612	570	†	†
		Cfm	†	1825	1750	1685	1610	1525	1485	1355	1215	†	†
048	Low	Watts	†	†	854	786	744	706	641	606	557	511	†
		Cfm	†	†	2026	1905	1830	1752	1603	1513	1367	1228	†
	High	Watts	†	†	†	905	846	824	804	748	683	637	†
		Cfm	†	†	†	2025	1905	1830	1752	1603	1398	1228	†
060	Low	Watts	1104	1093	1072	1029	986	938	891	830	769	733	697
		Cfm	1876	1865	1840	1803	1765	1710	1641	1533	1425	1345	1264
	Med	Watts	1351	1295	1245	1197	1148	1096	1053	994	936	871	812
		Cfm	2249	2209	2157	2097	2036	1959	1882	1781	1679	1542	1405
	High	Watts	†	†	1391	1343	1296	1247	1191	1129	1067	1002	936
		Cfm	†	†	2299	2231	2152	2060	1975	1859	1746	1591	1441

\*Air delivery values are without air filter and are for dry coil. See Table 17 for wet coil pressure drop. Deduct field-supplied air filter pressure drop and wet coil pressure drop to obtain external static pressure available for ducting.

†Unit air delivery is outside of operating range.

NOTE: Do not operate the unit at a cooling airflow that is less than 350 cfm for each 12,000 Btuh of rated cooling capacity. Evaporator-coil icing may occur at airflows below this point. Water blow-off may occur at airflows above 450 cfm per 12,000 Btuh of rated cooling capacity.

**Table 12 — Dry-Coil Air Delivery\* — Downflow Discharge at 230 and 460 V — Unit 48SS  
(Deduct 10% from Cfm and Watts for 208 V Operation)**

UNIT 48SS	MOTOR SPEED	AIR DELIVERY	EXTERNAL STATIC PRESSURE (in. wg)										
			0.0	0.1	0.2	0.3	0.4	0.5	0.6	0.7	0.8	0.9	1.0
018	Low	Watts	†	295	251	223	201	176	149	124	†	†	†
		Cfm	†	821	817	753	665	536	343	164	†	†	†
	High	Watts	401	376	346	322	294	272	250	229	219	†	†
		Cfm	1334	1253	1128	996	816	658	461	246	167	†	†
024, 030	Low	Watts	†	285	284	282	278	274	270	261	251	244	230
		Cfm	†	798	761	727	682	634	581	525	450	371	304
	Med	Watts	†	378	371	368	362	357	343	332	315	301	283
		Cfm	†	1011	982	948	906	858	771	703	597	492	387
	High	Watts	†	520	511	487	472	451	431	411	385	362	341
		Cfm	†	1342	1309	1237	1181	1106	1007	892	745	610	471
036	Low	Watts	†	460	439	423	398	379	349	322	297	270	246
		Cfm	†	1191	1136	1081	1005	907	795	687	579	471	349
	Med	Watt	†	511	492	470	450	420	392	364	332	308	275
		Cfm	†	1316	1244	1178	1104	1005	891	784	657	535	389
	High	Watts	†	655	631	603	584	552	522	492	459	433	398
		Cfm	†	1541	1458	1367	1292	1178	1053	920	806	662	509
042	Low	Watts	†	637	612	587	560	526	493	455	†	†	†
		Cfm	†	1500	1450	1405	1350	1290	1200	1105	†	†	†
	High	Watts	†	790	750	700	679	639	608	574	547	†	†
		Cfm	†	1750	1675	1604	1509	1421	1323	1221	1094	†	†
048	Low	Watts	†	847	784	746	708	646	609	563	516	†	†
		Cfm	†	1995	1901	1822	1730	1580	1477	1319	1178	†	†
	High	Watts	†	†	909	852	820	801	751	687	639	†	†
		Cfm	†	†	2018	1896	1814	1729	1582	1380	1270	†	†
060	Low	Watts	†	983	950	923	885	845	804	751	697	665	633
		Cfm	†	1838	1808	1755	1702	1628	1553	1446	1339	1257	1175
	Med	Watts	†	1115	1083	1045	1006	964	921	872	823	783	742
		Cfm	†	2067	2023	1957	1891	1807	1723	1612	1501	1392	1282
	High	Watts	†	1284	1201	1166	1131	1092	1053	1001	950	907	864
		Cfm	†	2167	2108	2038	1968	1882	1796	1676	1555	1437	1318

\*Air delivery values are without air filter and are for dry coil. See Table 17 for wet coil pressure drop. Deduct field-supplied air filter pressure drop and wet coil pressure drop to obtain external static pressure available for ducting.

†Unit air delivery is outside of operating range.

NOTE: Do not operate the unit at a cooling airflow that is less than 350 cfm for each 12,000 Btu/h of rated cooling capacity. Evaporator-coil icing may occur at airflows below this point. Water blow-off may occur at airflows above 450 cfm per 12,000 Btu/h of rated cooling capacity.

**Table 13 — Dry-Coil Air Delivery\* — Horizontal Discharge at 230 and 460 V — Unit 48SX  
(Deduct 10% from Cfm and Watts for 208 V Operation)**

UNIT 48SX	MOTOR SPEED	AIR DELIVERY	EXTERNAL STATIC PRESSURE (in. wg)										
			0.0	0.1	0.2	0.3	0.4	0.5	0.6	0.7	0.8	0.9	1.0
024, 030	Low	Watts	280	275	265	255	250	245	240	†	†	†	†
		Cfm	820	810	755	700	660	600	560	†	†	†	†
	Med	Watts	365	360	350	345	340	330	320	310	300	†	†
		Cfm	1025	1010	975	940	900	850	800	720	630	†	†
	High	Watts	†	†	490	480	470	460	445	430	410	390	380
		Cfm	†	†	1300	1255	1200	1150	1080	1005	915	790	620
036	Low	Watts	520	495	474	458	445	425	†	†	†	†	†
		Cfm	1375	1335	1290	1240	1200	1140	†	†	†	†	†
	Med	Watts	575	560	535	510	480	460	440	425	†	†	†
		Cfm	1520	1490	1450	1400	1380	1300	1200	1080	†	†	†
	High	Watts	†	†	†	†	650	614	575	540	510	480	†
		Cfm	†	†	†	†	1560	1500	1380	1280	1170	1060	†
042	Low	Watts	490	480	470	460	450	430	410	390	†	†	†
		Cfm	1400	1380	1340	1300	1250	1200	1140	1070	†	†	†
	Med	Watts	590	580	560	545	525	505	480	450	420	†	†
		Cfm	1600	1560	1540	1470	1430	1360	1300	1220	1120	†	†
	High	Watts	†	†	†	†	†	700	670	640	600	560	500
		Cfm	†	†	†	†	†	1780	1670	1600	1480	1340	1100
048**	Low	Watts	1050	1000	970	930	870	810	750	680	600	†	†
		Cfm	1850	1830	1800	1785	1750	1700	1640	1500	1330	†	†
	High	Watts	†	†	†	1050	1000	930	870	810	740	665	†
		Cfm	†	†	†	2000	1940	1850	1750	1635	1500	1300	†

\*Air delivery values are without air filter and are for dry coil. See Table 17 for wet coil pressure drop. Deduct field-supplied air filter pressure drop and wet coil pressure drop to obtain external static pressure available for ducting.

†Unit air delivery is outside of operating range.

\*\*For 460 v units only.

NOTE: Do not operate the unit at a cooling airflow that is less than 350 cfm for each 12,000 Btu/h of rated cooling capacity. Evaporator-coil icing may occur at airflows below this point. Water blow-off may occur at airflows above 450 cfm per 12,000 Btu/h of rated cooling capacity.

**Table 14 — Dry-Coil Air Delivery\* — Downflow Discharge at 230 and 460 V — Unit 48SX  
(Deduct 10% from Cfm and Watts for 208 V Operation)**

UNIT 48SX	MOTOR SPEED	AIR DELIVERY	EXTERNAL STATIC PRESSURE (in. wg)										
			0.0	0.1	0.2	0.3	0.4	0.5	0.6	0.7	0.8	0.9	1.0
024, 030	Low	Watts	280	275	265	255	250	245	240	†	†	†	†
		Cfm	820	810	755	700	660	600	560	†	†	†	†
	Med	Watts	365	360	350	345	340	330	320	310	300	†	†
		Cfm	1025	1010	975	940	900	850	800	720	630	†	†
	High	Watts	†	†	490	480	470	460	445	430	410	390	380
		Cfm	†	†	1300	1255	1200	1150	1080	1005	915	790	620
036	Low	Watts	520	495	474	458	445	425	†	†	†	†	†
		Cfm	1375	1335	1290	1240	1200	1140	†	†	†	†	†
	Med	Watts	575	560	535	510	480	460	440	425	†	†	†
		Cfm	1520	1490	1450	1400	1380	1300	1200	1080	†	†	†
	High	Watts	†	†	†	†	650	614	575	540	510	480	†
		Cfm	†	†	†	†	1560	1500	1380	1280	1170	1060	†
042	Low	Watts	490	480	470	460	450	430	410	390	†	†	†
		Cfm	1400	1380	1340	1300	1250	1200	1140	1070	†	†	†
	Med	Watts	590	580	560	545	525	505	480	450	420	†	†
		Cfm	1600	1560	1540	1470	1430	1360	1300	1220	1120	†	†
	High	Watts	†	†	†	†	†	700	670	640	600	560	500
		Cfm	†	†	†	†	†	1780	1670	1600	1480	1340	1100
048**	Low	Watts	1050	1000	970	930	870	810	750	680	600	†	†
		Cfm	1850	1830	1800	1785	1750	1700	1640	1500	1330	†	†
	High	Watts	†	†	†	1050	1000	930	870	810	740	665	†
		Cfm	†	†	†	2000	1940	1850	1750	1635	1500	1300	†

\*Air delivery values are without air filter and are for dry coil. See Table 17 for wet coil pressure drop. Deduct field-supplied air filter pressure drop and wet coil pressure drop to obtain external static pressure available for ducting.

†Unit air delivery is outside of operating range.

\*\*For 460 v units only.

NOTE: Do not operate the unit at a cooling airflow that is less than 350 cfm for each 12,000 Btuh of rated cooling capacity. Evaporator-coil icing may occur at airflows below this point. Water blow-off may occur at airflows above 450 cfm per 12,000 Btuh of rated cooling capacity.

**Table 15 — Dry Coil Air Delivery\* — Heating — Horizontal and Downflow Discharge for Integrated Control Motor Units at 230-V (Deduct 10% from Cfm for 208-V Operation)**

HEATING INPUT (Btuh)	EASY SELECT BOARD TERMINALS (Cfm)			
	1	2	3	4
80,000	1300	1400	1600	1750
100,000	—	1400	1600	1750
95,000	—	—	1600	1750
136,000	—	—	—	1750

\*Air delivery values are for dry coil at 230 v. Airflow is independent of external static pressure within ±5% of table values up to 0.8 in wg.

NOTES:

1. Dashed areas do not fall within approved range.
2. The above values occur with the AC/HP CFMADJUST select jumper set on MED.
3. Airflow can be adjusted +10% or -10% by selecting HI or LO for all modes except FAN ONLY.

**Table 16 — Dry-Coil Air Delivery\* — Fan Only and Cooling — Horizontal and Downflow Discharge for Integrated Control Motor Units at 230-V (Deduct 10% from Cfm for 208-V Operation)**

UNIT 48SX	FAN ONLY (Cfm)	COOLING (Cfm)
048	1400	1600
060	1750	2000

\*Air delivery values are for dry coil at 230 v. Airflow is independent of external static pressure within ±5% of table values up to 0.8 in wg.

NOTE: Do not operate the unit at a cooling airflow that is less than 350 cfm for each 12,000 Btuh of rated cooling capacity. Evaporator-coil icing may occur at airflows below this point. Water blow-off may occur at airflows above 450 cfm per 12,000 Btuh of rated cooling capacity.

**Table 17 — Wet Coil Pressure Drop**

UNIT SIZE	AIRFLOW (cfm)	PRESSURE DROP (in. wg)
018*	600	0.069
	700	0.082
	800	0.102
	900	0.116
024	600	0.039
	700	0.058
	800	0.075
	900	0.088
030	900	0.088
	1000	0.095
	1200	0.123
036	1000	0.068
	1200	0.088
	1400	0.108
	1600	0.123
042	1000	0.048
	1200	0.069
	1400	0.088
048	1600	0.102
	1400	0.068
	1800	0.088
060	1700	0.082
	1900	0.095
	2100	0.108
	2300	0.123

\*Unit 48SS only.

**COOLING SEQUENCE OF OPERATION** — With the room thermostat SYSTEM switch in the COOL position and the FAN switch in the AUTO. position, the cooling sequence of operation is as follows:

When the room temperature rises to a point that is slightly above the cooling control setting of the thermostat, the thermostat completes the circuit between thermostat terminal R to terminals Y and G. These completed circuits through the thermostat connect contactor coil (C) (through unit wire Y) and blower relay coil (BR) (through unit wire G) across the 24-v secondary of transformer (TRAN).

NOTE: The blower relay coil (BR) is used on standard non-ICM units, ICM units use evaporator (indoor) fan on (IFO) connection.

The normally-open contacts of energized contactor (C) close and complete the circuit through compressor motor (COMP) to condenser (outdoor) fan motor (OFM). Both motors start instantly.

On standard non-ICM units, the set of normally-open contacts of energized relay BR close and complete the circuit through evaporator blower (indoor) fan motor (IFM). On ICM units, the IFO completes the circuit through evaporator blower IFM. The blower motor starts instantly.

NOTE: Once the compressor has started and then has stopped, it should not be started again until 5 minutes have elapsed.

The cooling cycle remains “on” until the room temperature drops to point that is slightly below the cooling control setting of the room thermostat. At this point, the thermostat “breaks” the circuit between thermostat terminal R to terminals Y and G. These open circuits deenergize contactor coil C and relay coil BR. The condenser and compressor motors stop. After a 30-second delay, the blower motor stops. The unit is in a “standby” condition, waiting for the next “call for cooling” from the room thermostat.

## MAINTENANCE

To ensure continuing high performance, and to minimize the possibility of premature equipment failure, periodic maintenance must be performed on this equipment. This combination heating/cooling unit should be inspected at least once each year by a qualified service person. To troubleshoot heating or cooling of units, refer to tables at the back of the book.

NOTE TO EQUIPMENT OWNER: Consult your local dealer about the availability of a maintenance contract.

### ⚠ WARNING

The ability to properly perform maintenance on this equipment requires certain expertise, mechanical skills, tools, and equipment. If you do not possess these, do not attempt to perform any maintenance on this equipment other than those procedures recommended in the User’s Manual. **FAILURE TO HEED THIS WARNING COULD RESULT IN SERIOUS PERSONAL INJURY AND POSSIBLE DAMAGE TO THIS EQUIPMENT.**

### ⚠ WARNING

Failure to follow these warnings could result in serious personal injury:

1. Turn off gas supply, *then* turn off electrical power to the unit before performing any maintenance or service on the unit.
2. Use extreme caution when removing panels and parts. As with any mechanical equipment, personal injury can result from sharp edges, etc.
3. Never place anything combustible either on, or in contact with, the unit.
4. Should overheating occur, or the gas supply fail to shut off, shut off the external main manual gas valve to the unit, *then* shut off the electrical supply.

### ⚠ CAUTION

Errors made when reconnecting wires may cause improper and dangerous operation. Label all wires prior to disconnection when servicing.

The minimum maintenance requirements for this equipment are as follows:

1. Inspect air filter(s) each month. Clean or replace when necessary.
2. Inspect indoor coil, drain pan, and condensate drain each cooling season for cleanliness. Clean when necessary.
3. Inspect blower motor and wheel for cleanliness and check lubrication each heating and cooling season. Clean and lubricate (if required) when necessary. For first heating season, inspect blower wheel bimonthly to determine proper cleaning frequency.
4. Check electrical connections for tightness and controls for proper operation each heating and cooling season. Service when necessary.
5. Check and inspect heating section before each heating season. Clean and adjust when necessary.
6. Check flue hood screen and remove any obstructions if necessary.
7. Check vent screen and clean if necessary.

## Air Filter

### ⚠ CAUTION

Never operate the unit without a suitable air filter in the return-air duct system. Always replace the filter with the same dimensional size and type as originally installed. See Tables 1 and 2 for recommended filter sizes.

Inspect air filter(s) at least once each month and replace (throwaway-type) or clean (cleanable-type) at least twice during each heating and cooling season or whenever the filter(s) becomes clogged with dust and lint.

## Unit Top Removal

NOTE: When performing maintenance or service procedures that require removal of the unit top, be sure to perform *all* of the routine maintenance procedures that require top removal, including: inspection of the heat exchanger area, coil inspection and cleaning, and condensate drain pan inspection and cleaning.

Only qualified service personnel should perform maintenance and service procedures that require unit top removal. Refer to the following top removal procedures:

1. Turn off gas supply, *then* turn off electric power to unit.
2. Remove all screws that secure unit top, including screws around 4 sides and those on top that screw into internal divider panels. Save all screws.
3. Lift top from unit carefully. Set top on edge.
4. Carefully replace and secure unit top to unit, using screws removed in Step 2, when maintenance and/or service procedures are completed. (Be sure to use original screws that have rubber washers to seal out water when securing top to internal divider panels.)

## Evaporator Blower and Motor

NOTE: Motors without oilers are prelubricated. Do not attempt to lubricate these motors.

For longer life, operating economy, and continuing efficiency, clean accumulated dirt and grease from the blower wheel and motor annually.

Lubricate the motor every 5 years if the motor is used intermittently (thermostat FAN switch in AUTO. position), or every 2 years if the motor is used continuously (thermostat FAN switch in ON position).

### ⚠ WARNING

Turn off the gas supply, *then* disconnect and tag electrical power to the unit before cleaning and lubricating the blower motor and wheel. Failure to adhere to this warning could cause personal injury or death.

To clean and lubricate the blower motor and wheel:

1. Remove and disassemble blower assembly as follows:
  - a. Remove blower access door.
  - b. On standard non-ICM units disconnect motor lead from blower relay (BR). Disconnect yellow lead from terminal L2 of the contactor.
  - c. On all units remove blower assembly from unit. Remove screws securing blower to gas partition and slide assembly out. Be careful not to tear insulation in blower compartment.
  - d. Ensure proper reassembly by marking blower wheel and motor in relation to blower housing before disassembly.
  - e. Loosen setscrew(s) that secures wheel to motor shaft, remove screws that secure motor mount brackets to

housing, and slide motor and motor mount out of housing.

2. Lubricate motor as follows:
  - a. Thoroughly clean all accumulations of dirt or grease from motor housing.
  - b. Remove dust caps or plugs from oil ports located at each end of motor.
  - c. Use a good grade of SAE 20 nondetergent motor oil and put one teaspoon ( $\frac{3}{16}$  oz. or 16 to 25 drops) in each oil port.
  - d. Allow time for oil to be absorbed by each bearing, then wipe excess oil from motor housing.
  - e. Replace dust caps or plugs in oil ports.
3. Remove and clean blower wheel as follows:
  - a. Ensure proper reassembly by marking wheel orientation.
  - b. Lift wheel from housing. When handling and/or cleaning blower wheel, be sure not to disturb balance weights (clips) on blower wheel vanes.
  - c. Remove caked-on dirt from wheel and housing with a brush. Remove lint and/or dirt accumulations from wheel and housing with vacuum cleaner, using soft brush attachment. Remove grease and oil with mild solvent.
  - d. Reassemble wheel into housing.
  - e. Reassemble motor into housing. Be sure setscrews are tightened on motor shaft flats and not on round part of shaft.
  - f. Reinstall blower access door.
4. Restore electrical power, then gas supply to unit. Start unit and check for proper blower rotation and motor speeds during heating and cooling cycles.

**Flue Gas Passageways** — To inspect the flue collector box and upper areas of the heat exchanger:

1. Remove the combustion blower wheel and motor assembly according to directions in Combustion-Air Blower section on page 46.
2. Remove the 3 screws holding the blower housing to the flue collector box cover (see Fig. 34).
3. Remove the 12 screws holding the flue collector box cover (Fig. 34) to the heat exchanger assembly. Inspect the heat exchangers.
4. Clean all surfaces as required using the wire brush.

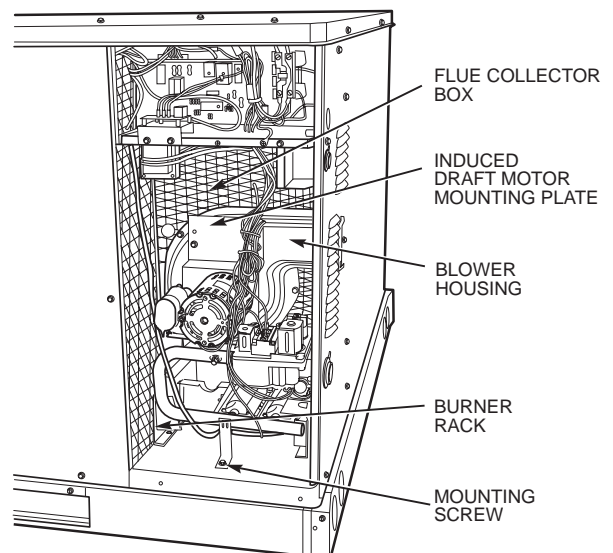

Fig. 34 — Blower Housing and Flue Collector Box



**Condenser Coil, Evaporator Coil, and Condensate Drain Pan** — Inspect the condenser coil, evaporator coil, and condensate drain pan at least once each year. Proper inspection and cleaning requires the removal of the unit top. See Unit Top Removal section on page 45.

The coils are easily cleaned when dry; therefore, inspect and clean the coils either before or after each cooling season. Remove all obstructions, including weeds and shrubs, that interfere with the airflow through the condenser coil. Straighten bent fins with a fin comb. If coated with dirt or lint, clean the coils with a vacuum cleaner, using the soft brush attachment. Be careful not to bend the fins. If coated with oil or grease, clean the coils with a mild detergent-and-water solution. Rinse coils with clear water, using a garden hose. Be careful not to splash water on motors, insulation, wiring, or air filter(s). For best results, spray condenser coil fins from inside to outside the unit. On units with an outer and inner condenser coil, be sure to clean between the coils. Be sure to flush all dirt and debris from the unit base.

Inspect the drain pan and condensate drain line when inspecting the coils. Clean the drain pan and condensate drain by removing all foreign matter from the pan. Flush the pan and drain tube with clear water. Do not splash water on the insulation, motor, wiring, or air filter(s). If the drain tube is restricted, clear it with a “plumbers snake” or similar probe device. Ensure that the auxiliary drain port above the drain tube is also clear.

### Condenser Fan

#### ▲ CAUTION

Keep the condenser fan free from all obstructions to ensure proper cooling operation. Never place articles on top of the unit. Damage to unit may result.

1. Remove 2 screws at bottom and 2 screws along sides of condenser air intake grille and remove plastic grille.
2. Inspect the fan blades for cracks or bends.
3. If fan needs to be removed, loosen the setscrew and slide the fan off the motor shaft.
4. When replacing fan blade, position blade so that leading edge is 1/2 in. in front of fan orifice. See Fig. 23.
5. Ensure that setscrew engages the flat area on the motor shaft when tightening.
6. Replace grille.

**Electrical Controls and Wiring** — Inspect and check the electrical controls and wiring annually. *Be sure to turn off the gas supply, and then the electrical power to the unit.*

Remove the control, blower, and compressor compartment access panels to locate all the electrical controls and wiring. Check all electrical connections for tightness. Tighten all screw connections. If any smoky or burned connections are noticed, disassemble the connection, clean all the parts, restrip the wire end and reassemble the connection properly and securely.

After inspecting the electrical controls and wiring, replace all the panels. Start the unit, and observe at least one complete heating cycle and one complete cooling cycle to ensure proper operation. If discrepancies are observed in either or both operating cycles, or if a suspected malfunction has occurred, check each electrical component with the proper electrical instrumentation. Refer to the unit wiring label when making these checkouts.

NOTE: Refer to the heating and/or cooling sequence of operation in this publication as an aid in determining proper control operation.

**Refrigerant Circuit** — Inspect all refrigerant tubing connections and the unit base for oil accumulations annually. Detecting oil generally indicates a refrigerant leak.

If oil is detected or if low cooling performance is suspected, leak-test all refrigerant tubing using an electronic leak-detector, halide torch, or liquid-soap solution. If a refrigerant leak is detected, refer to Check for Refrigerant Leaks section on page 23.

If no refrigerant leaks are found and low cooling performance is suspected, refer to Checking and Adjusting Refrigerant Charge section on page 35.

**Gas Input** — The gas input does not require checking unless improper heating performance is suspected. If a problem exists, refer to Start-Up section on page 23.

**Evaporator Airflow** — The heating and/or cooling airflow does not require checking unless improper performance is suspected. *If a problem exists, be sure that all supply- and return-air grilles are open and free from obstructions, and that the air filter is clean.* When necessary, refer to Evaporator Airflow and Airflow Adjustments section on page 35 to check the system airflow.

**Metering Device — Acutrol™ Device** — This metering device is a fixed orifice and is located in the header to the evaporator coil.

**Liquid Line Strainer** — The liquid line strainer (to protect metering device) is made of wire mesh and located in the liquid line on the inlet side of the metering device.

# TROUBLESHOOTING

## Cooling

SYMPTOM	CAUSE	REMEDY
<b>Compressor and condenser fan will not start.</b>	Power failure	Call power company.
	Fuse blown or circuit breaker tripped	Replace fuse or reset circuit breaker.
	Defective thermostat, contactor, transformer, or control relay	Replace component.
	Insufficient line voltage	Determine cause and correct.
	Incorrect or faulty wiring	Check wiring diagram and rewire correctly.
	Thermostat setting too high	Lower thermostat setting below room temperature.
<b>Compressor will not start but condenser fan runs.</b>	Faulty wiring or loose connections in compressor circuit	Check wiring and repair or replace.
	Compressor motor burned out, seized, or internal overload open	Determine cause. Replace compressor.
	Defective run/start capacitor, overload, start relay	Determine cause and replace.
	One leg of 3-phase power dead	Replace fuse or reset circuit breaker. Determine cause.
<b>Three-phase scroll compressor (Units 48SS048,060 and 48SX036-060 only) makes excessive noise, and there may be a low pressure differential.</b>	Scroll compressor is rotating in the wrong direction	Correct the direction of rotation by reversing the 3-phase power leads to the unit. Shut down unit to allow pressures to equalize.
<b>Compressor cycles (other than normally satisfying thermostat).</b>	Refrigerant overcharge or undercharge	Recover refrigerant, evacuate system, and recharge to capacities shown on nameplate.
	Defective compressor	Replace and determine cause.
	Insufficient line voltage	Determine cause and correct.
	Blocked condenser	Determine cause and correct.
	Defective run/start capacitor, overload or start relay	Determine cause and replace.
	Defective thermostat	Replace thermostat.
	Faulty condenser-fan motor or capacitor	Replace.
	Restriction in refrigerant system	Locate restriction and remove.
<b>Compressor operates continuously.</b>	Dirty air filter	Replace filter.
	Unit undersized for load	Decrease load or increase unit size.
	Thermostat set too low	Reset thermostat.
	Low refrigerant charge	Locate leak, repair, and recharge.
	Leaking valves in compressor	Replace compressor.
	Air in system	Recover refrigerant, evacuate system, and recharge.
	Condenser coil dirty or restricted	Clean coil or remove restriction.
<b>Excessive head pressure.</b>	Dirty air filter	Replace filter.
	Dirty condenser coil	Clean coil.
	Refrigerant overcharged	Recover excess refrigerant.
	Air in system	Recover refrigerant, evacuate system, and recharge.
	Condenser air restricted or air short-cycling	Determine cause and correct.
<b>Head pressure too low.</b>	Low refrigerant charge	Check for leaks, repair and recharge.
	Compressor valves leaking	Replace compressor.
	Restriction in liquid tube	Remove restriction.
<b>Excessive suction pressure.</b>	High heat load	Check for source and eliminate.
	Compressor valves leaking	Replace compressor.
	Refrigerant overcharged	Recover excess refrigerant.
<b>Suction pressure too low.</b>	Dirty air filter	Replace filter.
	Low refrigerant charge	Check for leaks, repair and recharge.
	Metering device or low side restricted	Remove source of restriction.
	Insufficient evaporator airflow	Increase air quantity. Check filter — replace if necessary.
	Temperature too low in conditioned area	Reset thermostat.
	Outdoor ambient below 40 F	Install low-ambient kit.
	Field-installed filter-drier restricted	Replace.



## Cooling (cont)

SYMPTOM	CAUSE	REMEDY
Integrated control motor (units 48SX048,060 208/230 v) IFM does not run.	Blower wheel not secured to shaft	Properly tighten blower wheel to shaft.
	Insufficient voltage at motor	Determine cause and correct.
	Power connectors not properly seated	Connectors should snap easily; do not force.
Integrated control motor (units 48SX048,060 208/230 v) IFM runs when it should be off.	Motor programmed with a delay profile	Allow a few minutes for motor to shut off.
	With thermostat in OFF the voltage on G,Y1,Y/Y2,W with respect to common, should be 1/2 of actual low voltage supply	If measured voltage is more than 1/2, the thermostat is incompatible with motor. If voltage is less than 1/2, the motor has failed.
Integrated control motor (units 48SX048,060 208/230 v) IFM operation is intermittent.	Water dripping into motor	Verify proper drip loops in connector wires.
	Connectors not firmly seated	Gently pull wires individually to be sure they are crimped into the housing.

IFM — Evaporator (Indoor) Fan Motor

## Heating

SYMPTOM	CAUSE	REMEDY
Burners will not ignite.	Water in gas line	Drain. Install drip leg.
	No power to furnace	Check power supply fuses, wiring, or circuit breaker.
	No 24-v power supply to control circuit	Check transformer. NOTE: Some transformers have internal overcurrent protection that requires a cool-down period to reset.
	Miswired or loose connections	Check all wiring and wirenut connections.
	Burned-out heat anticipator in thermostat	Replace thermostat.
	Broken thermostat wire	Run continuity check. Replace wire if necessary.
	Misaligned spark electrodes	Check flame ignition and sense electrode positioning. Adjust as necessary.
	No gas at main burners	1. Check gas line for air. Purge as necessary. NOTE: After purging gas line of air, wait at least 5 minutes for any gas to dissipate before attempting to light unit. 2. Check gas valve.
Inadequate heating.	Dirty air filter	Clean or replace filter as necessary.
	Gas input to furnace too low	Check gas pressure at manifold. Match with that on unit nameplate.
	Unit undersized for application	Replace with proper unit or add additional unit.
	Restricted airflow	Clean or replace filter. Remove any restriction.
	Blower speed too low	Use faster speed tap if available, or install alternate motor.
	Limit switch cycles main burners	Check rotation of blower, thermostat heat anticipator settings, temperature rise of unit. Adjust as necessary.
Poor flame characteristics.	Incomplete combustion results in: Aldehyde odors, carbon monoxide, sooting flame, floating flame	1. Tighten all screws around burner compartment. 2. Cracked heat exchanger. Replace. 3. Unit overfired. Reduce input (change orifices or adjust gas line or manifold pressure). 4. Check burner alignment.

## LED Troubleshooting — Error Code

SYMPTOM	CAUSE	REMEDY
<b>Hardware failure. (LED OFF)</b>	Loss of power to control module (IGC).	Check 5 amp fuse on IGC, power to unit, 24-v circuit breaker, and transformer. Units without a 24-v circuit breaker have an internal overload in the 24-v transformer. If the overload trips, allow 10 minutes for automatic reset.
<b>Limit switch fault. (LED 2 flashes)</b>	High temperature limit switch is open.	Check the operation of the indoor (evaporator) fan motor. Ensure that the supply-air temperature rise is in accordance with the range on the unit nameplate.
<b>Flame sense fault. (LED 3 flashes)</b>	The IGC sensed flame that should not be present.	Reset unit. If problem persists, replace control board.
<b>4 consecutive limit switch faults. (LED 4 flashes)</b>	Inadequate airflow to unit.	Check operation of indoor (evaporator) fan motor and that supply-air temperature rise agrees with range on unit nameplate information.
<b>Ignition lockout. (LED 5 flashes)</b>	Unit unsuccessfully attempted ignition for 15 minutes.	Check ignitor and flame sensor electrode spacing, gaps, etc. Ensure that flame sense and ignition wires are properly terminated. Verify that unit is obtaining proper amount of gas.
<b>Induced-draft motor fault. (LED 6 flashes)</b>	IGC does not sense that induced-draft motor is operating.	Check for proper voltage. If motor is operating, check the speed sensor plug/IGC Terminal J2 connection. Proper connection: PIN 1 — White, PIN 2 — Red, PIN 3 — Black.
<b>Rollout switch fault. (LED 7 flashes)</b>	Rollout switch has opened.	Rollout switch will automatically reset, but IGC will continue to lockout unit. Check gas valve operation. Ensure that induced-draft blower wheel is properly secured to motor shaft. Reset unit at unit disconnect.
<b>Internal control fault. (LED 8 flashes)</b>	Microprocessor has sensed an error in the software or hardware.	If error code is not cleared by resetting unit power, replace the IGC.

### ⚠ WARNING

If the IGC must be replaced, be sure to ground yourself to dissipate any electrical charge that may be present before handling new control board. The IGC is sensitive to static electricity and may be damaged if the necessary precautions are not taken.

IMPORTANT: Refer to Heating troubleshooting chart for additional troubleshooting analysis.

#### LEGEND

**IGC** — Integrated Gas Unit Controller  
**LED** — Light-Emitting Diode

## SERVICE TRAINING

**Packaged Service Training** programs are an excellent way to increase your knowledge of the equipment discussed in this manual, including:

- Unit Familiarization
- Maintenance
- Installation Overview
- Operating Sequence

A large selection of product, theory, and skills programs are available, using popular video-based formats and materials. All include video and/or slides, plus companion book.

**Classroom Service Training** which includes “hands-on” experience with the products in our labs can mean increased confidence that really pays dividends in faster troubleshooting and fewer callbacks. Course descriptions and schedules are in our catalog.

**CALL FOR FREE CATALOG 1-800-962-9212**

[ ] Packaged Service Training      [ ] Classroom Service Training



**START-UP CHECKLIST**  
**(Remove and Store in Job File)**

**I. PRELIMINARY INFORMATION**

MODEL NO.: \_\_\_\_\_

SERIAL NO.: \_\_\_\_\_

DATE: \_\_\_\_\_

TECHNICIAN: \_\_\_\_\_

**II. PRE-START-UP (insert checkmark in box as each item is completed)**

- VERIFY THAT ALL PACKING MATERIALS HAVE BEEN REMOVED FROM UNIT
- VERIFY THAT CONDENSATE CONNECTION IS INSTALLED PER INSTALLATION INSTRUCTIONS
- CHECK ALL ELECTRICAL CONNECTIONS AND TERMINALS FOR TIGHTNESS
- CHECK GAS PIPING FOR LEAKS
- CHECK THAT INDOOR (EVAPORATOR) AIR FILTER IS CLEAN AND IN PLACE
- VERIFY THAT UNIT INSTALLATION IS LEVEL
- CHECK FAN WHEEL AND PROPELLER FOR LOCATION IN HOUSING/ORIFICE AND SETSCREW TIGHTNESS

**III. START-UP**

**ELECTRICAL**

SUPPLY VOLTAGE    L1-L2 \_\_\_\_\_    L2-L3 \_\_\_\_\_    L3-L1 \_\_\_\_\_  
COMPRESSOR AMPS    L1 \_\_\_\_\_    L2 \_\_\_\_\_    L3 \_\_\_\_\_  
COMPRESSOR AMPS    L1 \_\_\_\_\_    L2 \_\_\_\_\_    L3 \_\_\_\_\_  
INDOOR (EVAPORATOR) FAN AMPS    \_\_\_\_\_

**TEMPERATURES**

OUTDOOR (CONDENSER) AIR TEMPERATURE    \_\_\_\_\_ DB  
RETURN-AIR TEMPERATURE    \_\_\_\_\_ DB    \_\_\_\_\_ WB  
COOLING SUPPLY AIR    \_\_\_\_\_  
GAS HEAT SUPPLY AIR    \_\_\_\_\_

**PRESSURES**

GAS INLET PRESSURE    \_\_\_\_\_ IN. WG  
GAS MANIFOLD PRESSURE    \_\_\_\_\_ IN. WG  
REFRIGERANT SUCTION    \_\_\_\_\_ PSIG  
REFRIGERANT DISCHARGE    \_\_\_\_\_ PSIG

- VERIFY REFRIGERANT CHARGE USING CHARGING TABLES
- VERIFY THAT 3-PHASE SCROLL COMPRESSOR (48SS048,060 AND 48SX036-060 UNITS) ROTATING IN CORRECT DIRECTION

CUT ALONG DOTTED LINE

## Free Manuals Download Website

<http://myh66.com>

<http://usermanuals.us>

<http://www.somanuals.com>

<http://www.4manuals.cc>

<http://www.manual-lib.com>

<http://www.404manual.com>

<http://www.luxmanual.com>

<http://aubethermostatmanual.com>

Golf course search by state

<http://golfingnear.com>

Email search by domain

<http://emailbydomain.com>

Auto manuals search

<http://auto.somanuals.com>

TV manuals search

<http://tv.somanuals.com>