



Turn to the Experts.™

Installation Instructions



**Designed and Assembled
in the USA.**

US patents: US20060165149 A1, USD578026 SI, US6205041 B1

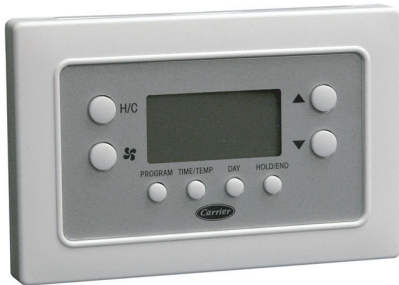

A07107

Base Series Programmable Thermostat

NOTE: Read the entire instruction manual before starting the installation

TABLE OF CONTENTS

	PAGE
SAFETY CONSIDERATIONS	1
INTRODUCTION	1
INSTALLATION CONSIDERATIONS	1
INSTALLATION	2
Step 1 — Thermostat Location	2
Step 2 — Install Thermostat	2
Step 3 — Set Thermostat Configuration	3
Step 4 — Understand Thermostat Operation	3
Step 5 — Check Thermostat Operation	4
WIRING DIAGRAMS	4

SAFETY CONSIDERATIONS

Improper installation, adjustment, alteration, service, maintenance, or use can cause explosion, fire, electrical shock, or other conditions which may cause death, personal injury, or property damage. Consult a qualified installer, service agency, or your distributor or branch for information or assistance. The qualified installer or agency must use factory-authorized kits or accessories when modifying this product. Refer to the individual instructions packaged with the kits or accessories when installing.

Follow all safety codes. Wear safety glasses, protective clothing, and work gloves. Have a fire extinguisher available. Read these instructions thoroughly and follow all warnings or cautions

included in literature and attached to the unit. Consult local building codes and the current editions of the National Electrical Code (NEC) NFPA 70.

In Canada, refer to the current editions of the Canadian Electrical Code CSA C22.1.

Recognize safety information. This is the safety-alert symbol . When you see this symbol on the unit and in the instructions or manuals, be alert to the potential for personal injury.

Understand the signal words **DANGER**, **WARNING**, and **CAUTION**. These words are used with the safety-alert symbol. **DANGER** identifies the most serious hazards which **will** result in severe personal injury or death. **WARNING** signifies a hazard which **could** result in personal injury or death. **CAUTION** is used to identify unsafe practices which **may** result in minor personal injury or product and property damage. **NOTE** is used to highlight suggestions which **will** result in enhanced installation, reliability, or operation.

INTRODUCTION

There are two Base Series programmable thermostat models, one for AC applications and one for HP applications. Both are dual powered, operating from either 24VAC or two alkaline AA batteries. Configuration and program schedules are stored in non-volatile memory, preserving this information during power loss and battery removal. Features include simplified 5/2 day programming, large backlit display, and modern styling.

The AC model provides one stage of heating and one stage of cooling.

The HP model provides two stages of heating and one stage of cooling.

INSTALLATION CONSIDERATIONS

AC Operation

For 24VAC operation, both the R and C wires must be connected to the 24VAC power source. Batteries are not needed.

Battery Operation

When batteries are used, the common (C) connection is not needed, saving a wire, and eliminating 24VAC operation. The thermostat continues to operate in the event of a power failure. Battery life is expected to be one year. A “low battery” reminder tells the homeowner when it is time to replace the batteries. When connected without the common wire, the thermostat will not operate without batteries. Continuous back-lighting is not available.

Both Battery and AC Operation

If both batteries and 24VAC operation are used (batteries installed and the common wire connected), and indefinite clock operation are provided, the battery will be used only during AC power loss, extending battery life to nearly its shelf life.

A jumper has to be properly set for backlight operation. J2 should be set in the “AC” position when the thermostat is operated from 24VAC. J2 should be set in the “BAT” position when the

thermostat is operated from batteries. The thermostat will continue to operate if J2 is not in the correct position or not connected. However, the backlight will not operate.

INSTALLATION

IMPORTANT: Install batteries last to ensure proper thermostat mounting and latch engagement.

Step 1 — Thermostat Location

Thermostat should be mounted:

- Approximately 5 ft (1.5m) from floor.
- Close to or in a frequently used room, preferably on an inside partitioning wall.
- On a section of wall without pipes or duct work.

Thermostat should NOT be mounted:

- Close to a window, on an outside wall, or next to a door leading to the outside.
- Exposed to direct light and heat from the sun, a lamp, fireplace, or other heat-radiating object which may cause a false reading.
- Close to or in direct airflow from supply registers and return-air grilles.
- In areas with poor air circulation, such as behind a door or in an alcove.

Step 2 — Install Thermostat

IMPORTANT: Install batteries last to ensure proper thermostat mounting and latch engagement.

⚠ WARNING

ELECTRICAL OPERATION HAZARD

Failure to follow this warning could result in personal injury or death.

Before installing thermostat, turn off all power to unit. There may be more than 1 disconnect. Lock out and tag switch with a suitable warning label.

1. Turn OFF all power to HVAC unit.
2. If an existing thermostat is being replaced:
 - a. Remove existing thermostat from wall.
 - b. Disconnect wires from existing thermostat, one at a time. Be careful not to allow wires to fall back into wall.
 - c. As each wire is disconnected, record wire color and terminal marking.
 - d. Discard or recycle old thermostat.

⚠ CAUTION

ENVIRONMENTAL HAZARD

Failure to follow this caution may result in environmental damage.

Mercury is a hazardous waste and may be found in the old thermostat. Federal regulations require that Mercury be disposed of properly.

3. Separate front and back plastic assembly of thermostat.
4. Route thermostat wires through hole in mounting base. Level mounting base against wall (for aesthetic value only, thermostat need not be level for proper operation) and mark wall through 2 mounting holes.
5. Drill two 3/16-in. (5mm) mounting holes in wall where marked.

6. Secure back plate to wall with 2 anchors and screws provided making sure all wires extend through hole in plastic.

NOTE: Anchoring the back plate will maximize proper mounting plate flatness and allow latch to fully engage.

7. Connect wires to proper terminal location on backplate.
8. Push any excess wire back into wall. Seal hole in wall to prevent air leaks. Leaks can affect thermostat operation. Any excess wire left inside thermostat casing may also affect thermostat operation by interfering with airflow across the temperature sensor.
9. Set the thermostat front housing into the (2) latches (notches) on the bottom of the back plate.



A08429

10. Rotate the front housing forward and press on the faceplate with thumbs near the Up/Down arrows on the right and the "H/C" and fan symbols on the left side of the display. Do this with a moderate amount of pressure.



A08430

11. If necessary, continue to rotate the front housing forward and press to engage the top corner latches.



A08431

12. Snap thermostat together making sure assembly is secure.
13. Install the batteries.

14. Turn ON power to unit.

On power up, depending on the thermostat model being used, the LCD readout will display either AC for air conditioner model (1-stage heat/1-stage cool) or HP for heat pump model (2-stage heat/1-stage cool).

Step 3 — Set Thermostat Configuration

Configuration options enable the installer to configure the thermostat for a particular installation.

These are not presented to the homeowner and therefore must be properly set by the installer. Following is a list of the options available, an explanation of their function, and their factory default settings. Not all numbers are used in the Base Series because not all options are available in this series.

Configuration Options - Summary:

- Option 01 - Equipment type
- Option 03 - Fahrenheit/Centigrade
- Option 04 - Fan (G) on with W output
- Option 10 - Reversing valve
- Option 13 - Room air temperature offset
- Option 21 - Keypad Lockout
- Option 26 - Minimum Cooling Setpoint
- Option 27 - Maximum Heating Setpoint

To Enter The Configuration Mode:

Press and hold the FAN key for about 10 seconds until the display changes so that only two pairs of digits are showing. The configuration number, now 01, will appear in the setpoint/temperature location and the configuration setting will appear in the clock location. The configuration number (left pair) will be flashing which means it can be adjusted using the UP and DOWN keys. To cause the opposite pair to flash (to be adjustable), press the H/C key. Successive presses of the H/C key alternate between the configuration number (left) and the configuration setting (right). To exit the configuration mode, press the HOLD/END key. If no key is pressed for 3 minutes, the configuration mode will automatically exit, returning the thermostat to normal operation.

Configuration Options - Selection:

Option 01 - Equipment type

Selections: with HP thermostat: HP, AC, PH, or PC
with AC thermostat: AC or PC

Meanings:

PH or PC selects PTAC units (Packaged Terminal Air Conditioners) which are used in motel rooms and other rented spaces. When this option is selected, the display shows only the setpoint, not the room temperature. Also, the compressor timeguard is disabled, allowing the compressor to turn on immediately when a demand is established.

HP or PH controls 1 speed heat pump with 1 stage of aux heat.

AC or PC controls 1 speed air conditioner with one stage of heat.

Note that this option allows a HP thermostat to be converted to control an AC system.

Option 03 - Fahrenheit/Centigrade

Selections: F = Fahrenheit — This is default.
C = Centigrade.

Selects temperature display units.

Option 04 - Fan (G) ON with W output

Selections: OF = G not energized with W — This is default.
ON = G energized with W.

This selection determines whether the fan (G) is to be ON or OFF when the W (furnace or strip heat) is ON. Furnaces and fan coils which manage their own blowers do not require a separate G

signal. Some auxiliary heaters require a separate G signal to operate the blower when W is applied.

This option allows a HP thermostat to control an AC system.

Option 10 - Reversing valve

Selections: C = reversing valve energized in cooling — This is default.

H = reversing valve energized in heating — Only appears in HP systems.

Option 13 - Room Air Temperature Offset

Selections: $\pm 5^{\circ}\text{F} / 3^{\circ}\text{C}$. Default is 0.

The number of degrees to be added to the displayed temperature to calibrate or deliberately miscalibrate the measured room temperature. This option is in $^{\circ}\text{F}$ even if Option 3 is set for $^{\circ}\text{C}$.

Option 21 - Keypad Lockout

Selections: ON, OF — Default is OF.

With OF selected, the keypad cannot be locked. With ON selected the keypad will be locked and can be unlocked by simultaneously pressing the UP and DOWN keys for 5 seconds. Once unlocked, it will relock 2 minutes after the last keypad press. If any key is pressed and the thermostat is locked, "loc" will be displayed in the clock digits.

Option 26 - Minimum Cooling Setpoint

Selections: 50° to $90^{\circ}\text{F} / 10^{\circ}$ to 32°C — Default is $52^{\circ}\text{F} / 11^{\circ}\text{C}$.
Sets the lowest cooling setpoint available to the user.

Option 27 - Maximum Heating Setpoint

Selections: 50° to $90^{\circ}\text{F} / 10^{\circ}$ to 32°C — Default is $88^{\circ}\text{F} / 31^{\circ}\text{C}$.
Sets the highest heating setpoint available to the user.

Step 4 — Understand Thermostat Operation

Temperature Display

Thermostat will display room temperature until UP or DOWN button is pressed. The words SET TEMP appear when these buttons are pressed and the current setpoint is displayed. If no buttons are pressed for 5 sec, the display will change back to show room temperature.

Back lighting

Continuous back-lighting is not available. The backlight will come on for 10 seconds after any button press. Without AC power and when the battery is low, the backlight will remain off with button presses.

Battery Indicator

A battery indication icon on the display shows nothing, half, or low/no battery condition. If the battery is full or operation is from AC power, no icon appears. Under battery operation, if the battery is half full, a half full battery icon appears. As the battery depletes below half, the icon remains at half, but the 10 second backlight disappears. When the battery is absent or depleted, the display goes blank except for an empty battery icon and all outputs are turned off.

Timeguard Timer

A 5-minute timeguard is built into the thermostat immediately upon power up, and any time the compressor turns off. The compressor will not turn on until the timeguard has expired. The timeguard affects only compressor operation. Pressing UP and FAN buttons simultaneously will override the timeguard for 1 cycle. If PTAC operation (PH or PC) is selected under Option 1, the timeguard timer is eliminated.

Cycle Timer

In normal heating and cooling operation the thermostat will not allow more than 4 equipment cycles per hour (or 1 cycle every 15 minutes). Both the Y and W outputs have a 15-minute timer that starts counting down when the output is turned on, (e.g., if Y output is turned on for 9 minutes and then satisfies, it cannot turn back on for another 6 minutes regardless of demand). However,

pressing UP and FAN buttons simultaneously or changing the setpoint will override the timer for 1 cycle.

Minimum on Timer

Once the equipment has turned on, it will remain on for a minimum of 3 minutes regardless of demand. However, the equipment can turn off in less than 3 minutes if a change in setpoint, or a change in mode occurs.

Staging Timer

If the thermostat is a heat pump model, it has 2-stage heat capability. In normal operation there is a 15-minute delay between the first and second stages of heat. The Y output will energize first, then 15 minutes later, W is allowed to come on if the thermostat determines it is not satisfying the demand.

However, if the heating demand is greater than 5°F/3°C, there will be only a 30 second delay before bringing on W.

Auxiliary Heat Indicator

When operating a heat pump and either auxiliary heat or emergency heat is active, an LCD display icon indicates this condition.

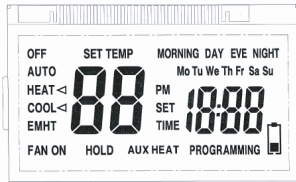

A07821

Error Messages

If the room temperature sensor fails, two dashes (--) will appear in the temperature display and all heating and cooling outputs will be turned off. The thermostat must be replaced.

If the internal non-volatile memory fails, E4 will alternately flash with the temperature on the display and all heating and cooling outputs will be turned off. The thermostat must be replaced.

Step 5 — Check Thermostat Operation

Fan Operation

1. Press FAN button. This will start continuous fan operation. FAN ON icon will turn on.
2. Press FAN button again. This will stop continuous fan operation. FAN ON icon will turn off.

Heating Operation

1. Press H/C button until HEAT is displayed.
2. Press UP button until LCD readout reads 3°F/2°C above room temperature. Press UP and FAN buttons simultaneously to defeat timers. Heating system should begin to operate immediately.
3. For HP thermostats only, press H/C button until EMHT (emergency heat) appears. Press UP and FAN buttons simultaneously to defeat timers. Emergency heating (W is ON, Y is OFF) should begin immediately.

Cooling Operation

1. Press H/C button until COOL is displayed.
2. Press DOWN button until LCD readout reads 3°F/2°C below room temperature. Press UP and FAN buttons simultaneously to defeat timers. Cooling system should begin to operate immediately.

Table 1 shows the thermostat outputs for each available stage of heating or cooling. It may be useful in checkout or troubleshooting.

Table 1 – Outputs

EQUIPMENT CONFIGURATION OPTION #1	THERMOSTAT TYPE CONFIGURATION	COOL STAGE 1	HEAT STAGE 1	HEAT STAGE 2	EM HEAT
AC, PC	AC, HP	Y, G	W	--	--
HP, PH RVS = C	HP	Y, G, O/B	Y, G	Y, G, W	W
HP, PH RVS = H	HP	Y, G	Y, G, O/B	Y, G, W, O/B	W

WIRING DIAGRAMS

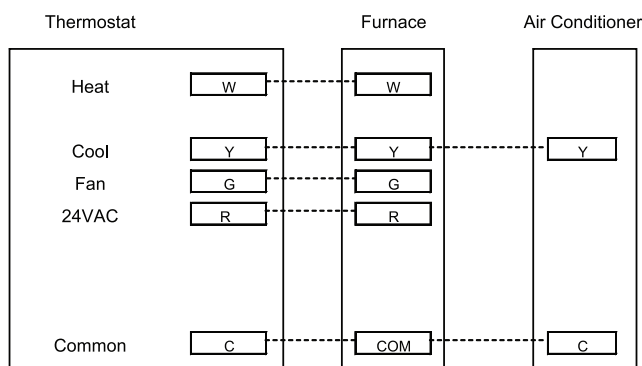

A06566

Fig. 1 - A/C Thermostat Typical Installation

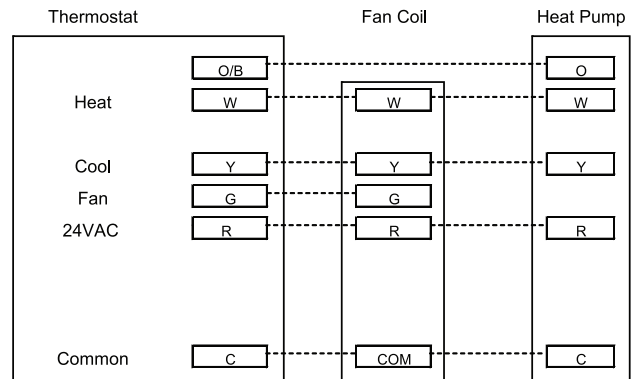

A06567

Fig. 2 - HP Thermostat Typical Installation

Homeowner's Guide



Designed and Assembled
in the USA.



A07107

Base Series Programmable Thermostat SETTING TIME AND DAY

At Power Up

When power is first applied, AC or HP will appear for 5 seconds to tell you it is an air conditioner (AC) or a heat pump (HP) model. After this, the time display will flash to tell you the power has been off.

Setting The Current Time:

1. Press the TIME/TEMP button. SET TIME flashes on the display.
2. Press the UP or DOWN button until the correct time is displayed.
3. To quickly advance to the proper time, press and hold the UP or DOWN button.
4. When the correct time appears on the display, press the HOLD/END button.

NOTE: If you choose not to press the HOLD/END button, the thermostat will automatically exit the time setting mode after 10 seconds.

Setting The Current Day:

1. Press the DAY button to advance to the correct day.
2. When the correct day appears on the display, press the HOLD/END button.

MANUAL OPERATION

To Operate Manually (Without the Programmed Comfort Schedule):

Press the HOLD/END button to make the HOLD icon appear. Then follow the four steps below:

1. To Select the Mode:

Use the H/C button to move between the choices. OFF, HEAT, COOL, or EMHT will appear on the display. EMHT will only appear on heat pump models.

2. To Select the Fan Operation:

Use the FAN button to move between continuous fan (indicated by the FAN ON icon) and auto fan operation.

3. To Read the Room Temperature:

The large display reads room temperature until a button is pressed.

4. To Adjust the Setpoint:

In normal operation, the large display shows room temperature. At the first press of the UP or DOWN button, the large display shows the current setpoint and the SET TEMP icon is turned on. Further presses of the UP or DOWN button adjust the setpoint upward or downward. Five seconds after the last button press, the display returns to the room temperature and the SET TEMP icon turns off.

PROGRAMMED OPERATION

Introduction

The Base Series Programmable Thermostat provides four periods per day (MORNING, DAY, EVE, NIGHT) and two schedules per week (MoTuWeThFr and SaSu). A separate time, heat setpoint, and cool setpoint can be set for each period and schedule. Before starting to actually program the thermostat, fill out Table 1 with the values you wish to program. (The Energy Star®, US Department of Energy recommended time and temperature values are already programmed for you as a starting point and are shown on the left side of the table.)

The first press of the PROGRAM button brings up the programming mode and places you at morning of the current day and period. Successive presses move you between the four daily periods.

While Programming:

The TIME/TEMP button moves between three selections of SET TIME, SET TEMP & HEAT, and SET TEMP & COOL. These three numbers are to be programmed for each of the periods MORNING, DAY, EVE, and NIGHT.

The DAY button moves between the weekdays, (MoTuWeThFr) and the weekend (SaSu) selections. A different schedule may be set for the weekdays and the weekend. You may exit programming at any time by pressing the HOLD/END button.

Programming A Weekly Comfort Schedule:

1. Press the PROGRAM button. The word PROGRAMMING appears on the display and the words SET TIME flash on the display. MoTuWeThFr or SaSu and the morning period icons will appear on the display. The current mode (HEAT or COOL) will also show. Use the DAY button to select weekdays and the PROGRAM button to select MORNING.
2. Press the UP or DOWN button to set the start time for MORNING (1) value in Table 1).
3. Press the TIME/TEMP button until COOL is on and SET TEMP flashes on the display.
4. Press the UP or DOWN button to select the cooling temperature setpoint (2) value in Table 1).
5. Press the TIME/TEMP button until HEAT is on and SET TEMP flashes on the display.
6. Press the UP or DOWN buttons to select the heating temperature setpoint (3) value in Table 1).
7. Press the PROGRAM button to advance to the next time period. Enter time and temperature settings (4) through 12 in Table 1) for the periods DAY, EVE, and NIGHT by following items 2-6 above.
8. Press the DAY button to change between weekday and weekend programming. To set the weekend schedule, repeat items 2 through 7, entering values in 13) through 24) in Table 1.
9. Press END/HOLD to exit the programming mode.

Modifying Your Weekly Comfort Schedule

If you choose to change any of your weekly schedule, press PROGRAM at any time. You will enter the programming schedule at the present day, present mode, but always in the morning period. You are ready to set the new starting time for the morning period. One press of the TIME/TEMP button and you are ready to set the new morning temperature. To set values for other periods, use the PROGRAM button. To set values for other days, use the DAY button. Press HOLD/END and you are finished.

Overriding Your Comfort Schedule

There are two ways to override your comfort schedule.

Method 1 — Manual Operation

By pressing the HOLD/END button to turn on the HOLD icon, the thermostat will maintain the current temperature settings and ignore the comfort schedule for an indefinite period of time. The word HOLD will appear in the display. Press the HOLD/END button a second time and the thermostat will return the temperature

settings to the programmed comfort schedule. Pressing HOLD/END will not alter your programmed comfort schedule.

Method 2 — Temporary Override

At the first press of the UP or DOWN button, the current temperature setting will appear on the display. Pressing the UP or DOWN button again will temporarily change the setpoint as needed. At the next programmed time, the programmed comfort schedule will resume.

CHANGING BATTERIES

In some situations, two AA batteries are the power source for the thermostat. If batteries are used with your equipment then they should last about one year. As the batteries lose their power a battery icon appears on the display. As the batteries get weaker, the icon goes down to one black bar and then none. As the icon becomes empty, you will begin to lose thermostat functions because the batteries are losing their power. When the batteries are completely dead, you won't be able to use the thermostat.

When using batteries for power, we recommend you replace them with two AA alkaline batteries. They are in a compartment under the lid on top of the thermostat. You do not have to remove the thermostat from the wall to replace the batteries. Simply open the lid, lift out the batteries, and replace them like you would any other battery operated device.

TROUBLESHOOTING

What if AUX HEAT appears on the display? (Heat pump model only)

If auxiliary heat is on, you will see AUX HEAT indicator in the display. When it is on this means the system has determined that it's too cold outside for your heat pump to heat the house without help, so it's getting help from the electric heaters. This happens automatically.

NOTE: This indicator does not mean there is a problem with your system.

What if E-Heat appears on the display?

If the heat pump is not working properly, you can manually turn on the emergency heat for extra help in heating. You'll know there's a problem if the house can't seem to get warm when it's cold outside.

You want to avoid using emergency heat, though, because it's the most expensive option. And, of course, if you suspect a problem with your heat pump, call your heating and cooling dealer immediately.

Table 1 – Programming Table

ENERGY STAR FACTORY DEFAULT VALUES				NEW COMFORT SCHEDULE					
PERIOD	TIME	COOL	HEAT	MoTuWeThFr TIME	COOL	HEAT	SaSu TIME	COOL	HEAT
MORNING	6:00 A.M.	78°F 26°C	68°F 20°C	1)	2)	3)	13)	14)	15)
DAY	8:00 A.M.	85°F 29°C	60°F 16°C	4)	5)	6)	16)	17)	18)
EVE	5:00 P.M.	78°F 26°C	68°F 20°C	7)	8)	9)	19)	20)	21)
NIGHT	10:00 P.M.	82°F 28°C	60°F 16°C	10)	11)	12)	22)	23)	24)



Limited Warranty for Thermostats, User Interfaces, Zoning and Related Accessories

FOR WARRANTY SERVICE OR REPAIR:

Contact the installer or a Carrier dealer. You may find the installer’s name on the equipment or in your Owner’s Packet. You can also find a Carrier dealer online at www.carrier.com.

For help, contact: Carrier Corporation, Consumer Relations, P.O. Box 4808, Syracuse, New York 13221 Phone: 1-800-227-7437

PRODUCT REGISTRATION: You can register your product online at www.carrier.com.

Model No./Serial No. _____ Series (Infinity, Performance, Comfort, Base,) _____
 Date of Installation _____ Installed by _____
 Name of Owner _____ Address of Installation _____

Carrier Corporation (hereinafter “Company”) warrants this product against failure due to defect in materials or workmanship under normal use and maintenance as follows. All warranty periods begin on the date of original installation. If a part fails due to defect during the applicable warranty period Company will provide a new or remanufactured part, at Company’s option, to replace the failed defective part at no charge for the part. Alternatively, and at its option, the Company will allow a credit in the amount of the then factory selling price for a new equivalent part toward the retail purchase price of a new Company product. Except as otherwise stated herein, those are Company’s exclusive obligations under this warranty for a product failure. This limited warranty is subject to all provisions, conditions, limitations and exclusions listed below and on the reverse (if any) of this document.

OWNER-OCCUPIED, RESIDENTIAL APPLICATIONS

This warranty is to the original purchasing owner and is transferable only to the extent and as stated in the Warranty Conditions and below. The warranty period in years, depending on the part and the claimant, is as shown in the chart below.

Series	Item	Limited Warranty (Years)	
		Original Owner	Subsequent Owner
Infinity	User Interface & Smart Sensor	10* (or 5)	10** (or 5)
	Zoning Board	10* (or 5)	10** (or 5)
	Network Interface	10* (or 5)	10** (or 5)
	Remote Access	10* (or 5)	10** (or 5)
Performance	Thermostat***	10* (or 5)	10** (or 5)
	Zoning Interface & Smart Sensor	10* (or 5)	10** (or 5)
	Zoning System	10* (or 5)	10** (or 5)
Comfort	Thermostat	10* (or 5)	10** (or 5)
	Zoning Board	10* (or 5)	10** (or 5)
Base	Thermostat	5	5

- * If properly registered within 90 days, otherwise 5 years (except in California and Quebec and other jurisdictions that prohibit warranty benefits conditioned on registration, registration is not required to obtain longer warranty periods). See Warranty Conditions below.
- ** If properly transferred within 90 days, otherwise 5 years. See Warranty Conditions below. In California and Quebec and other jurisdictions that prohibit warranty benefits conditioned on registration, registration is not required for a transfer and all warranty periods for subsequent owners are five years from original installation.
- *** Applies only to Thermostats. Active electronic finished good accessories, such as the optional ExP module, have different warranty terms. See product for details.

OTHER RESIDENTIAL APPLICATIONS (Apartments, Rental Properties, etc.)

The warranty period is five (5) years and is not transferable.

OTHER APPLICATIONS

This warranty is non-transferable. The warranty period is one (1) year on all such applications.

LEGAL REMEDIES: The owner must notify the Company in writing, by certified or registered letter to Carrier Corporation, Warranty Claims, P.O. Box 4808, Syracuse, New York 13221, of any defect or complaint with the product, stating the defect or complaint and a specific request for repair, replacement, or other correction of the product under warranty, mailed at least thirty (30) days before pursuing any legal rights or remedies.

49004DP110
05/09

TB-- PAC / TB - PHP



WARRANTY CONDITIONS:

1. To obtain the longer warranty periods as shown in the table under original owner, for the original purchaser, the product must be properly registered at www.carrier.com within ninety (90) days of original installation. In jurisdictions where warranty terms conditioned on registration are prohibited by law, registration is not required and the longer warranty period shown will be apply.
2. Where a product is installed in a newly constructed home, the date of installation is the date the homeowner purchased the home from the builder.
3. If the date of original installation cannot be verified, then the warranty period begins ninety (90) days from the date of product manufacture (as indicated by the model and serial number). Proof of purchase may be required at time of service.
4. The remainder of the first five years of warranty is freely transferable without registration. To obtain a transfer of the longer warranty periods as shown in the table under subsequent owner, a subsequent owner must register the transfer at www.carrier.com within 90 days of the change in ownership and payment of a transfer fee. Not applicable in all jurisdictions. See website for details.
5. Product must be installed properly and by a licensed HVAC technician.
6. The warranty applies only to products remaining in their original installation location.
7. Installation, use, care, and maintenance must be normal and in accordance with instructions contained in the Installation Instructions, Owner's Manual and Company's service information.
8. Defective parts must be returned to the distributor through a registered servicing dealer for credit.

LIMITATIONS OF WARRANTIES: ALL IMPLIED WARRANTIES AND/OR CONDITIONS (INCLUDING IMPLIED WARRANTIES OR CONDITIONS OF MERCHANTABILITY AND FITNESS FOR A PARTICULAR USE OR PURPOSE) ARE LIMITED TO THE DURATION OF THIS LIMITED WARRANTY. SOME STATES OR PROVINCES DO NOT ALLOW LIMITATIONS ON HOW LONG AN IMPLIED WARRANTY OR CONDITION LASTS, SO THE ABOVE MAY NOT APPLY TO YOU. THE EXPRESS WARRANTIES MADE IN THIS WARRANTY ARE EXCLUSIVE AND MAY NOT BE ALTERED, ENLARGED, OR CHANGED BY ANY DISTRIBUTOR, DEALER, OR OTHER PERSON, WHATSOEVER.

THIS WARRANTY DOES NOT COVER:

1. Labor or other costs incurred for diagnosing, repairing, removing, installing, shipping, servicing or handling of either defective parts, or replacement parts, or new units.
2. Any product purchased over the Internet.
3. Normal maintenance as outlined in the installation and servicing instructions or Owner's Manual, including filter cleaning and/or replacement and lubrication.
4. Failure, damage or repairs due to faulty installation, misapplication, abuse, improper servicing, unauthorized alteration or improper operation.
5. Failure to start due to voltage conditions, blown fuses, open circuit breakers, or damages due to the inadequacy or interruption of electrical service.
6. Failure or damage due to floods, winds, fires, lightning, accidents, corrosive environments (rust, etc) or other conditions beyond the control of Company.
7. Parts not supplied or designated by Company, or damages resulting from their use.
8. Products installed outside the U.S.A. or its territories and Canada.
9. Electricity or fuel costs, or increases in electricity or fuel costs from any reason whatsoever, including additional or unusual use of supplemental electric heat.
10. Any cost to replace, refill or dispose of refrigerant, including the cost of refrigerant.
11. **ANY SPECIAL, INDIRECT OR CONSEQUENTIAL PROPERTY OR COMMERCIAL DAMAGE OF ANY NATURE WHATSOEVER.** Some states or provinces do not allow the exclusion of incidental or consequential damages, so the above limitation may not apply to you.

This Warranty gives you specific legal rights, and you may also have other rights which vary from state to state or province to province.

49004DP110

05/09

TB-PAC / TB-PHP

Free Manuals Download Website

<http://myh66.com>

<http://usermanuals.us>

<http://www.somanuals.com>

<http://www.4manuals.cc>

<http://www.manual-lib.com>

<http://www.404manual.com>

<http://www.luxmanual.com>

<http://aubethermostatmanual.com>

Golf course search by state

<http://golfingnear.com>

Email search by domain

<http://emailbydomain.com>

Auto manuals search

<http://auto.somanuals.com>

TV manuals search

<http://tv.somanuals.com>