

EO, PO, MOV & MOH

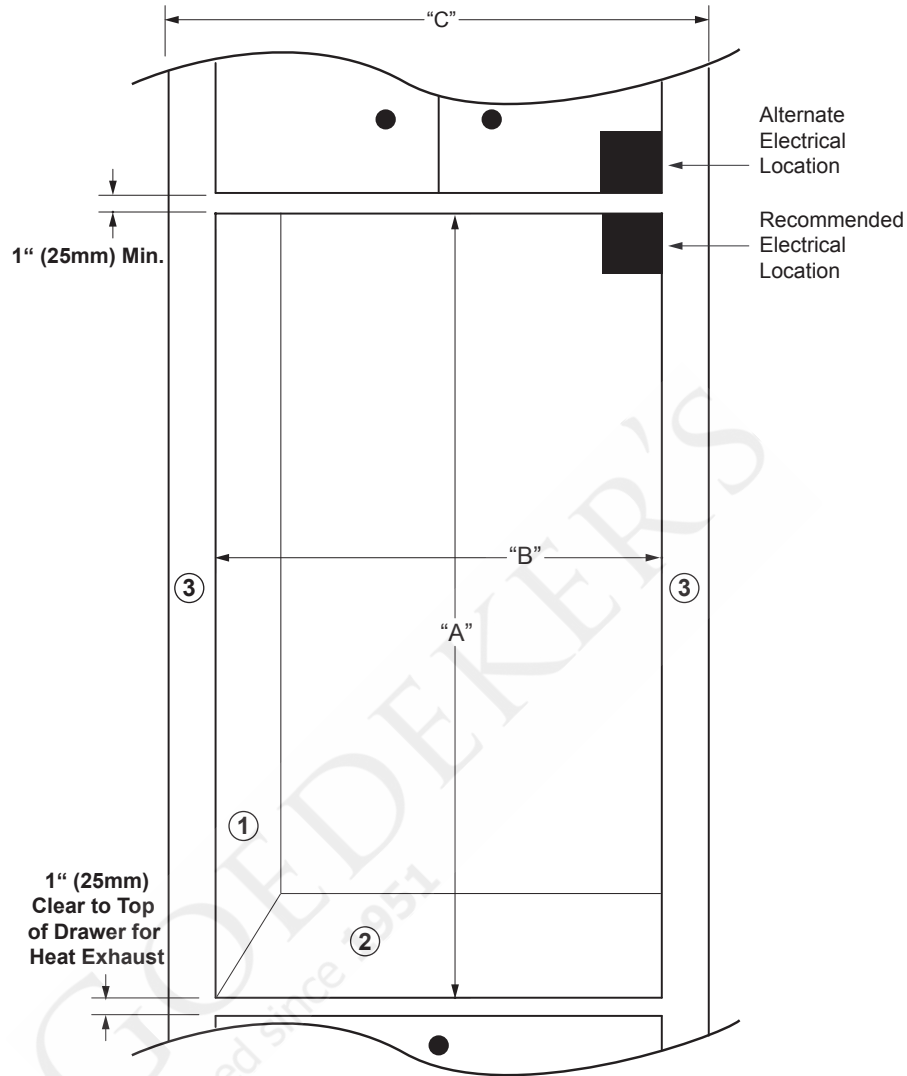

CUTOUT DIMENSIONS

Models	"A" Cutout Height	"B" Cutout Width	"C" Min. Cabinet Width	Oven Overlays
27"	50 9/16" (1284mm)	25 1/2" (648mm)	27" (686mm)	3/4" (19mm) Each Side; 15/16" (24mm) Top; 1/16" (1mm) Bottom
30"		28 1/2" (724mm)	30" (762mm)	

NOTES:

1. **24" (610mm) minimum interior cabinet depth.**
Back of cabinet may need to be removed.
2. **3/4" (19mm) support platform (flush with cutout).**
3. **1/8" (3mm) minimum clearance from appliance to adjacent cabinet doors/drawers.**

EO, PO, MOV & MOH

dacor
The life of the kitchen™

101905

27, 30" Wide, Double, Wall Ovens

2/2

PLANNING GUIDE

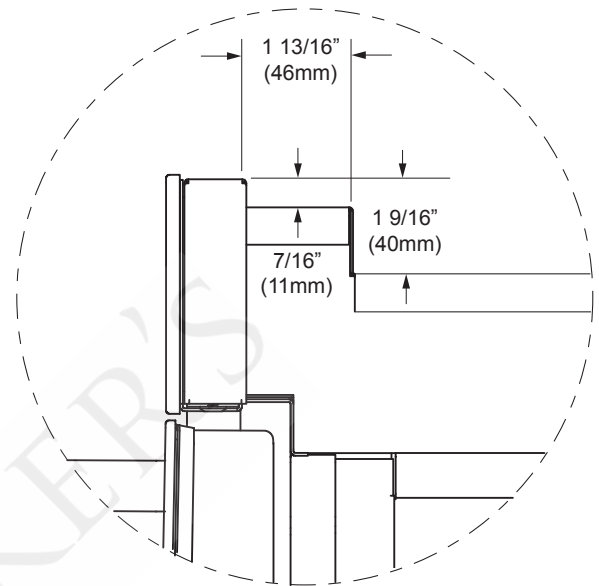
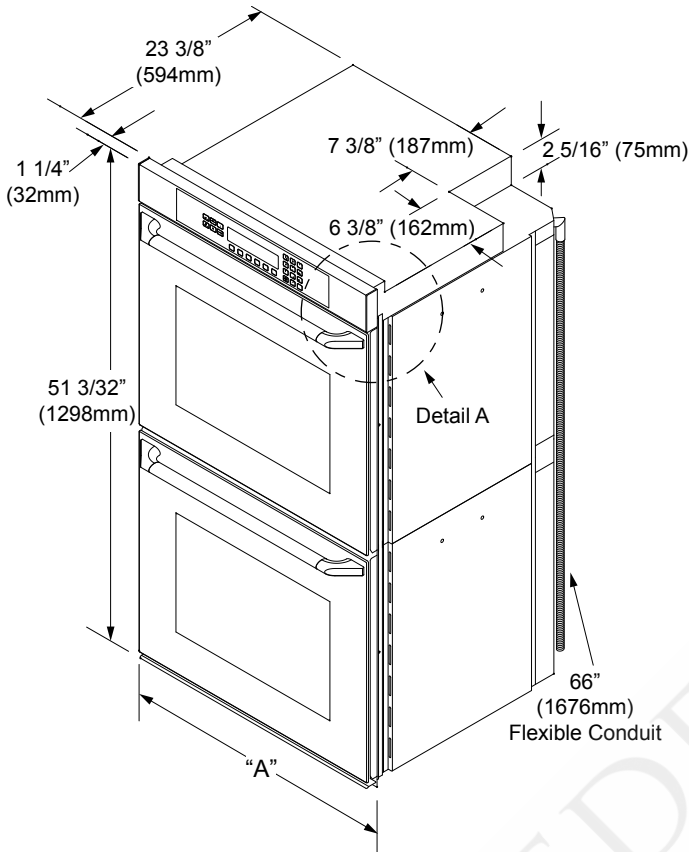

DETAIL A

OVERALL DIMENSIONS

Models	"A" Oven Width
27"	27" (686mm)
30"	30" (672mm)

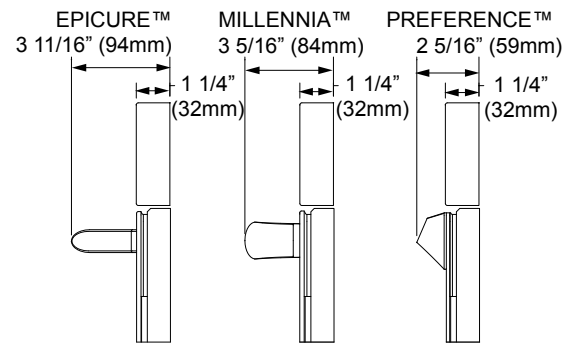

OVEN HANDLE DIMENSIONS

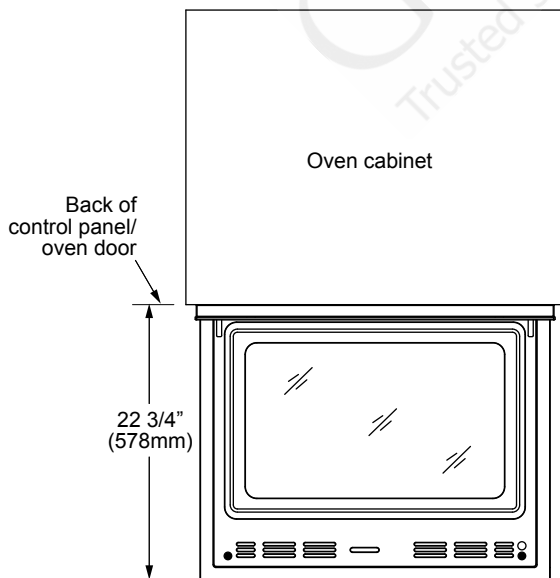

TOP VIEW with DOOR OPEN

Dedicated Circuit Required	Total Connected Load	Approximate Shipping Weight
240VAC, 4-wire, 60Hz, 40A (Breaker)	8.6kW (37A)	415 lbs.

Web: <http://www.dacor.com>
Corporate Phone: 800-793-0093

Specifications are subject to change without notice. **1.8**
See installation instructions for additional details. L65346 rev B

Free Manuals Download Website

<http://myh66.com>

<http://usermanuals.us>

<http://www.somanuals.com>

<http://www.4manuals.cc>

<http://www.manual-lib.com>

<http://www.404manual.com>

<http://www.luxmanual.com>

<http://aubethermostatmanual.com>

Golf course search by state

<http://golfingnear.com>

Email search by domain

<http://emailbydomain.com>

Auto manuals search

<http://auto.somanuals.com>

TV manuals search

<http://tv.somanuals.com>