

DeVILBISS AIR POWER COMPANY

General Manual

Oil Lubricated Two-Stage Stationary Air Compressor

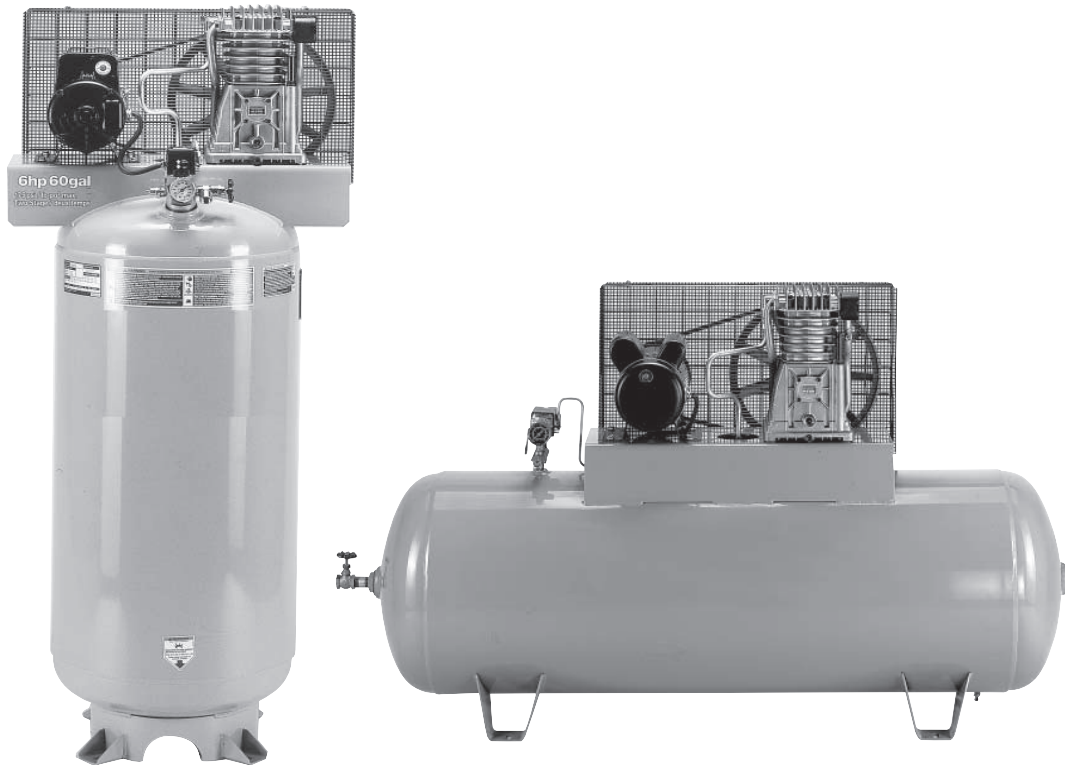

SAFETY GUIDELINES - DEFINITIONS

This manual contains information that is important for you to know and understand. This information relates to protecting **YOUR SAFETY** and **PREVENTING EQUIPMENT PROBLEMS**. To help you recognize this information, we use the symbols to the right. Please read the manual and pay attention to these sections.

⚠ DANGER

DANGER indicates an imminently hazardous situation which, if not avoided, will result in **death or serious injury**.

⚠ CAUTION

CAUTION indicates a potentially hazardous situation which, if not avoided, **may** result in **minor or moderate injury**.

⚠ WARNING

WARNING indicates a potentially hazardous situation which, if not avoided, **could** result in **death or serious injury**.

CAUTION

CAUTION used without the safety alert symbol indicates a potentially hazardous situation which, if not avoided, **may** result in **property damage**.

Call our **Toll Free Number 1-800-888-2468, Ext 2, then 1**, to obtain the location of the nearest Authorized Service Center for ordering repair parts and for warranty repairs.

When ordering repair parts from your local Authorized Service Center, always give the following information:

- Model number of your compressor
- Part number and description of the item you wish to purchase

Retain Original Sales Receipt as Proof of Purchase for Warranty Repair Work.

TABLE OF CONTENTS

SAFETY GUIDELINES -DEFINITIONS	1	MAINTENANCE	13
GENERAL INFORMATION	2	SERVICE INSTRUCTIONS	14-16
ON-RECEIPT INSPECTION	2	Air Filter-Inspection and Replacement	14
WARRANTY STATEMENT	3	Oil-Checking and Changing	14
IMPORTANT SAFETY INSTRUCTIONS	4-6	Viscosity Chart	14
SPECIFICATIONS	7	Oil Type	14
GLOSSARY	7	Oil Capacity	14
DUTY CYCLE	7	Check Valve-Inspection and Replacement ...	14
INSTALLATION	7-10	Safety Valve-Inspection and Replacement ...	15
Location of Air Compressor	7-8	Belt-Replacement	15
Air Compressor Anchoring Methods	8	Adjusting Belt Tension	15
Wiring Instructions and Diagram	8	Motor Pulley and Flywheel Alignment	15
Voltage and Circuit Protection	9	Motor Overload Protector-Reset	16
Grounding Instructions	9	Motor Lubrication	16
Lubrication and Oil	9	Air compressor Head Bolts-Torquing	16
Additional Regulators & Controls	9	Additional Service	16
Piping Instructions	10	STORAGE	16
DESCRIPTION OF OPERATION	11	TROUBLESHOOTING GUIDE	17-20
BREAK-IN PROCEDURES	12	ACCESSORIES	Back Cover
OPERATING PROCEDURES	12		

NOTE: Photographs and line drawings used in this manual are for reference only and do not represent a specific model.

GENERAL INFORMATION

You have purchased a complete air compressor outfit consisting of an air compressor, air tank, electric motor, and associated controls and instruments. The outfit you have selected is a stationary model and contains a two stage air compressor pump.

Your new air compressor outfit can be used for operating paint sprayers, air tools, grease guns, air brushes, caulking guns, sandblasters, inflating tires, etc.

A regularly scheduled program of preventive maintenance will help provide the long life that has been designed into your air compressor outfit. Before operating or performing any maintenance on your air compressor, refer to this manual and your Outfit Parts Manual. To keep your air compressor in good working order, refer to these publications often and perform preventive maintenance steps as recommended.

ON-RECEIPT Inspection

Each air compressor outfit is carefully checked before shipment. With improper handling, damage may result in transit and cause problems in air compressor operation.

Immediately upon arrival, check equipment for both concealed and visible damages to avoid expenses being incurred to correct such problems. This should be done regardless of any visible signs of damage to the shipping container.

Report any damages to carrier and arrange for inspection of goods immediately.

For the location or a listing of the nearest DeVilbiss Air Power Authorized Warranty Service Center, call our toll free number at **1-800-888-2468, Ext. 2.**

LIMITED WARRANTY

ONE YEAR FROM DATE OF PURCHASE

All merchandise manufactured by DeVilbiss Air Power Company Manufacturing is warranted to be free of defects in workmanship and material which occur during the first year from the date of purchase by the original purchaser (initial user). Products covered under this warranty include: air compressors, *air tools, accessories, service parts, pressure washers, and generators used in consumer applications (i.e., personal residential household usage only).

Air compressors, *air tools, accessories, service parts, pressure washers, and generators used in commercial applications (income producing) are covered by a 90 day warranty.

DeVilbiss Air Power Manufacturing will repair or replace, at DeVilbiss' option, products or components which have failed within the warranty period. Repair or replacement, and service calls on 60 and 80 gallon air compressors, will be handled by Authorized Warranty Service Centers and will be scheduled and serviced according to the normal work flow and business hours at the service center location, and depending on the availability of replacement parts.

All decisions of DeVilbiss Air Power Company Manufacturing with regard to this policy shall be final.

This warranty gives you specific legal rights, and you may also have other rights which vary from state to state.

RESPONSIBILITY OF ORIGINAL PURCHASER (Initial User):

- Retain original cash register sales receipt as proof of purchase for warranty work.
- Use reasonable care in the operation and maintenance of the product as described in the Owners Manual(s).
- Deliver or ship the product to the nearest DeVilbiss Air Power Manufacturing Authorized Warranty Service Center. Freight costs, if any, must be paid by the purchaser.
- Air compressors with 60 and 80 gallon tanks only will be inspected at the site of installation. Contact the nearest Authorized Warranty Service Center, that provides on-site service calls, for service call arrangement.
- If the purchaser does not receive satisfactory results from the Authorized Warranty Service Center, the purchaser should contact DeVilbiss Air Power Company Manufacturing.

THIS WARRANTY DOES NOT COVER:

- Merchandise sold as reconditioned, floor models and/or display models. Any damaged or incomplete equipment sold "as is".
- Merchandise used as "rental" equipment.
- Merchandise that has become inoperative because of ordinary wear, misuse, freeze damage, use of improper chemicals, negligence, accident, improper and/or unauthorized repair or alterations including failure to operate the product in accordance with the instructions provided in the Owners Manual (s) supplied with the product.
*Air Tools: O-Rings and driver blades are considered ordinary wear parts, therefore, they are warranted for a period of 45 days from the date of purchase.
- An air compressor that pumps air more than 50% during a one hour period is considered misuse because the air compressor is undersized for the required air demand. Maximum compressor pumping time per hour is 30 minutes.
- Merchandise sold by DeVilbiss Air Power Manufacturing which has been manufactured by and identified as the product of another company. The product manufacturer's warranty will apply.
- Repair and transportation costs of merchandise determined not to be defective.
- Cost associated with assembly, required oil, adjustments or other installation and start-up cost.
- ANY INCIDENTAL, INDIRECT OR CONSEQUENTIAL LOSS, DAMAGE, OR EXPENSE THAT MAY RESULT FROM ANY DEFECT, FAILURE OR MALFUNCTION OF THE PRODUCT.** Some states do not allow the exclusion or limitation of incidental or consequential damages, so the above limitation or exclusion may not apply to you.
- IMPLIED WARRANTIES, INCLUDING THOSE OF MERCHANTABILITY AND FITNESS FOR A PARTICULAR PURPOSE, ARE LIMITED TO ONE YEAR FROM THE DATE OF ORIGINAL PURCHASE.** Some states do not allow limitations on how long an implied warranty lasts, so the above limitations may not apply to you.



213 Industrial Drive • Jackson, TN 38301-9615
Telephone: 1-800-888-2468, Ext. 2
FAX: 1-800-888-9036

Form: SP-100-G - 9/29/99

IMPORTANT SAFETY INSTRUCTIONS



SAVE THESE INSTRUCTIONS



⚠ WARNING

IMPROPER OPERATION OR MAINTENANCE OF THIS PRODUCT COULD RESULT IN SERIOUS INJURY AND PROPERTY DAMAGE. READ AND UNDERSTAND ALL WARNINGS AND OPERATING INSTRUCTIONS BEFORE USING THIS EQUIPMENT. SAVE THESE INSTRUCTIONS. OWNER'S MANUAL SHOULD REMAIN WITH UNIT AT ALL TIMES.

HAZARD

RISK OF EXPLOSION OR FIRE



WHAT CAN HAPPEN	HOW TO PREVENT IT
<p>IT IS NORMAL FOR ELECTRICAL CONTACTS WITHIN THE MOTOR AND PRESSURE SWITCH TO SPARK.</p> <p>IF ELECTRICAL SPARKS FROM COMPRESSOR COME INTO CONTACT WITH FLAMMABLE VAPORS, THEY MAY IGNITE, CAUSING FIRE OR EXPLOSION.</p> <p>RESTRICTING ANY OF THE COMPRESSOR VENTILATION OPENINGS WILL CAUSE SERIOUS OVERHEATING AND COULD CAUSE FIRE.</p> <p>UNATTENDED OPERATION OF THIS PRODUCT COULD RESULT IN PERSONAL INJURY OR PROPERTY DAMAGE.</p>	<p>ALWAYS OPERATE THE COMPRESSOR IN A WELL VENTILATED AREA FREE OF COMBUSTIBLE MATERIALS, GASOLINE OR SOLVENT VAPORS.</p> <p>IF SPRAYING FLAMMABLE MATERIALS, LOCATE COMPRESSOR AT LEAST 20 FEET AWAY FROM SPRAY AREA. AN ADDITIONAL LENGTH OF HOSE MAY BE REQUIRED.</p> <p>STORE FLAMMABLE MATERIALS IN A SECURE LOCATION AWAY FROM COMPRESSOR.</p> <p>NEVER PLACE OBJECTS AGAINST OR ON TOP OF COMPRESSOR. OPERATE COMPRESSOR IN AN OPEN AREA AT LEAST 12 INCHES AWAY FROM ANY WALL OR OBSTRUCTION THAT WOULD RESTRICT THE FLOW OF FRESH AIR TO THE VENTILATION OPENINGS.</p> <p>OPERATE COMPRESSOR IN A CLEAN, DRY, WELL VENTILATED AREA. DO NOT OPERATE UNIT INDOORS OR IN ANY CONFINED AREA.</p> <p>ALWAYS REMAIN IN ATTENDANCE WITH THE PRODUCT WHEN IT IS OPERATING.</p>

RISK OF BURSTING



AIR TANK: THE FOLLOWING CONDITIONS COULD LEAD TO A WEAKENING OF THE AIR TANK, AND RESULT IN A VIOLENT AIR TANK EXPLOSION AND COULD CAUSE PROPERTY DAMAGE OR SERIOUS INJURY.

WHAT CAN HAPPEN	HOW TO PREVENT IT
<ol style="list-style-type: none"> FAILURE TO PROPERLY DRAIN CONDENSED WATER FROM THE AIR TANK, CAUSING RUST AND THINNING OF THE STEEL AIR TANK. MODIFICATIONS OR ATTEMPTED REPAIRS TO THE AIR TANK. UNAUTHORIZED MODIFICATIONS TO THE UNLOADER VALVE, SAFETY VALVE, OR ANY OTHER COMPONENTS WHICH CONTROL AIR TANK PRESSURE. EXCESSIVE VIBRATION CAN WEAKEN THE AIR TANK AND CAUSE RUPTURE OR EXPLOSION. <p><u>ATTACHMENTS & ACCESSORIES:</u></p> <p>EXCEEDING THE PRESSURE RATING OF AIR TOOLS, SPRAY GUNS, AIR OPERATED ACCESSORIES, TIRES AND OTHER INFLATABLES CAN CAUSE THEM TO EXPLODE OR FLY APART, AND COULD RESULT IN SERIOUS INJURY.</p>	<p>DRAIN AIR TANK DAILY OR AFTER EACH USE. IF AIR TANK DEVELOPS A LEAK, REPLACE IT IMMEDIATELY WITH A NEW AIR TANK OR REPLACE THE ENTIRE COMPRESSOR.</p> <p>NEVER DRILL INTO, WELD, OR MAKE ANY MODIFICATIONS TO THE AIR TANK OR ITS ATTACHMENTS.</p> <p>THE AIR TANK IS DESIGNED TO WITHSTAND SPECIFIC OPERATING PRESSURES. NEVER MAKE ADJUSTMENTS OR PARTS SUBSTITUTIONS TO ALTER THE FACTORY SET OPERATING PRESSURES.</p> <p>FOR ESSENTIAL CONTROL OF AIR PRESSURE, YOU MUST INSTALL A PRESSURE REGULATOR AND PRESSURE GAUGE TO THE AIR OUTLET OF YOUR COMPRESSOR. FOLLOW THE EQUIPMENT MANUFACTURERS RECOMMENDATION AND NEVER EXCEED THE MAXIMUM ALLOWABLE PRESSURE RATING OF ATTACHMENTS. NEVER USE COMPRESSOR TO INFLATE SMALL LOW-PRESSURE OBJECTS SUCH AS CHILDREN'S TOYS, FOOTBALLS, BASKETBALLS. ETC.</p>

HAZARD

RISK FROM FLYING OBJECTS

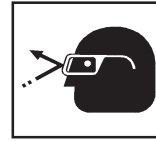

WHAT CAN HAPPEN	HOW TO PREVENT IT
<p>THE COMPRESSED AIR STREAM CAN CAUSE SOFT TISSUE DAMAGE TO EXPOSED SKIN AND CAN PROPEL DIRT, CHIPS, LOOSE PARTICLES AND SMALL OBJECTS AT HIGH SPEED, RESULTING IN PROPERTY DAMAGE OR PERSONAL INJURY.</p>	<p>ALWAYS WEAR ANSI Z87.1 APPROVED SAFETY GLASSES WITH SIDE SHIELDS WHEN USING THE COMPRESSOR.</p> <p>NEVER POINT ANY NOZZLE OR SPRAYER TOWARD ANY PART OF THE BODY OR AT OTHER PEOPLE OR ANIMALS.</p> <p>ALWAYS TURN THE COMPRESSOR OFF AND BLEED PRESSURE FROM THE AIR HOSE AND AIR TANK BEFORE ATTEMPTING MAINTENANCE, ATTACHING TOOLS OR ACCESSORIES.</p>

RISK TO BREATHING



WHAT CAN HAPPEN	HOW TO PREVENT IT
<p>THE COMPRESSED AIR FROM YOUR COMPRESSOR IS NOT SAFE FOR BREATHING! THE AIR STREAM MAY CONTAIN CARBON MONOXIDE, TOXIC VAPORS OR SOLID PARTICLES FROM THE AIR TANK.</p> <p>SPRAYED MATERIALS SUCH AS PAINT, PAINT SOLVENTS, PAINT REMOVER, INSECTICIDES, WEED KILLERS, CONTAIN HARMFUL VAPORS AND POISONS.</p>	<p>ALWAYS OPERATE AIR COMPRESSOR OUTSIDE IN A CLEAN, WELL VENTILATED AREA. AVOID ENCLOSED AREAS SUCH AS GARAGES, BASEMENTS, STORAGE SHEDS, WHICH LACK A STEADY EXCHANGE OF AIR. KEEP CHILDREN, PETS AND OTHERS AWAY FROM AREA OF OPERATION.</p> <p>NEVER INHALE AIR FROM THE COMPRESSOR EITHER DIRECTLY OR FROM A BREATHING DEVICE CONNECTED TO THE COMPRESSOR.</p> <p>WORK IN AN AREA WITH GOOD CROSS-VENTILATION. READ AND FOLLOW THE SAFETY INSTRUCTIONS PROVIDED ON THE LABEL OR SAFETY DATA SHEETS FOR THE MATERIAL YOU ARE SPRAYING. USE A NIOSH/MSHA APPROVED RESPIRATOR DESIGNED FOR USE WITH YOUR SPECIFIC APPLICATION.</p>

RISK OF ELECTRICAL SHOCK



WHAT CAN HAPPEN	HOW TO PREVENT IT
<p>YOUR AIR COMPRESSOR IS POWERED BY ELECTRICITY. LIKE ANY OTHER ELECTRICALLY POWERED DEVICE, IF IT IS NOT USED PROPERLY IT MAY CAUSE ELECTRIC SHOCK.</p> <p>REPAIRS ATTEMPTED BY UNQUALIFIED PERSONNEL CAN RESULT IN SERIOUS INJURY OR DEATH BY ELECTROCUTION.</p> <p>ELECTRICAL GROUNDING: FAILURE TO PROVIDE ADEQUATE GROUNDING TO THIS PRODUCT COULD RESULT IN SERIOUS INJURY OR DEATH FROM ELECTROCUTION. SEE GROUNDING INSTRUCTIONS.</p>	<p>NEVER OPERATE THE COMPRESSOR OUTDOORS WHEN IT IS RAINING OR IN WET CONDITIONS.</p> <p>NEVER OPERATE COMPRESSOR WITH COVER COMPONENTS REMOVED OR DAMAGED.</p> <p>ANY ELECTRICAL WIRING OR REPAIRS REQUIRED ON THIS PRODUCT SHOULD BE PERFORMED BY AUTHORIZED SERVICE CENTER PERSONNEL IN ACCORDANCE WITH NATIONAL AND LOCAL ELECTRICAL CODES.</p> <p>MAKE CERTAIN THAT THE ELECTRICAL CIRCUIT TO WHICH THE COMPRESSOR IS CONNECTED PROVIDES PROPER ELECTRICAL GROUNDING, CORRECT VOLTAGE AND ADEQUATE FUSE PROTECTION.</p>

HAZARD

RISK FROM MOVING PARTS

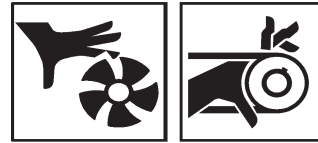

WHAT CAN HAPPEN	HOW TO PREVENT IT
<p>MOVING PARTS SUCH AS THE PULLEY, FLYWHEEL AND BELT CAN CAUSE SERIOUS INJURY IF THEY COME INTO CONTACT WITH YOU OR YOUR CLOTHING.</p> <p>ATTEMPTING TO OPERATE COMPRESSOR WITH DAMAGED OR MISSING PARTS OR ATTEMPTING TO REPAIR COMPRESSOR WITH PROTECTIVE SHROUDS REMOVED CAN EXPOSE YOU TO MOVING PARTS AND CAN RESULT IN SERIOUS INJURY.</p>	<p>NEVER OPERATE THE COMPRESSOR WITH GUARDS OR COVERS WHICH ARE DAMAGED OR REMOVED.</p> <p>ANY REPAIRS REQUIRED ON THIS PRODUCT SHOULD BE PERFORMED BY AUTHORIZED SERVICE CENTER PERSONNEL.</p>

RISK OF BURNS



WHAT CAN HAPPEN	HOW TO PREVENT IT
<p>TOUCHING EXPOSED METAL SUCH AS THE COMPRESSOR HEAD OR OUTLET TUBES, CAN RESULT IN SERIOUS BURNS.</p>	<p>NEVER TOUCH ANY EXPOSED METAL PARTS ON COMPRESSOR DURING OR IMMEDIATELY AFTER OPERATION. COMPRESSOR WILL REMAIN HOT FOR SEVERAL MINUTES AFTER OPERATION.</p> <p>DO NOT REACH AROUND PROTECTIVE SHROUDS OR ATTEMPT MAINTENANCE UNTIL UNIT HAS BEEN ALLOWED TO COOL.</p>

RISK OF FALLING



WHAT CAN HAPPEN	HOW TO PREVENT IT
<p>A PORTABLE COMPRESSOR CAN FALL FROM A TABLE, WORKBENCH OR ROOF CAUSING DAMAGE TO THE COMPRESSOR AND COULD RESULT IN SERIOUS INJURY OR DEATH TO THE OPERATOR.</p>	<p>ALWAYS OPERATE COMPRESSOR IN A STABLE SECURE POSITION TO PREVENT ACCIDENTAL MOVEMENT OF THE UNIT. NEVER OPERATE COMPRESSOR ON A ROOF OR OTHER ELEVATED POSITION. USE ADDITIONAL AIR HOSE TO REACH HIGH LOCATIONS.</p>

RISK OF PROPERTY DAMAGE WHEN TRANSPORTING COMPRESSOR (Fire, Inhalation, Damage to Vehicle Surfaces)



WHAT CAN HAPPEN	HOW TO PREVENT IT
<p>OIL CAN LEAK OR SPILL AND COULD RESULT IN FIRE OR BREATHING HAZARD, SERIOUS INJURY OR DEATH CAN RESULT. OIL LEAKS WILL DAMAGE CARPET, PAINT OR OTHER SURFACES IN VEHICLES OR TRAILERS.</p>	<p>ALWAYS PLACE COMPRESSOR ON A PROTECTIVE MAT WHEN TRANSPORTING TO PROTECT AGAINST DAMAGE TO VEHICLE FROM LEAKS. REMOVE COMPRESSOR FROM VEHICLE IMMEDIATELY UPON ARRIVAL AT YOUR DESTINATION.</p>

ESW-99 — 9/26/99

SPECIFICATIONS

Refer to Outfit Parts Manual for the specifications of your air compressor. Use only a fuse or circuit breaker that is the same rating as the branch circuit the air compressor is operated on. If the air compressor is connected to a circuit protected by fuses,

use dual element time delay fuses, as noted in that Service Manual. Some air compressors require a magnetic starter. Check Outfit Parts Manual for magnetic starter requirements.

⚠ CAUTION

Improper electrical installation of this product may void its warranty and your fire insurance. Have circuit wiring performed by qualified personnel such as a licensed electrician who is familiar with the current national electric code and any prevailing local electrical codes.

GLOSSARY

CFM: Cubic feet per minute.

SCFM: Standard cubic feet per minute; a unit of measure of air delivery.

PSIG: Pounds per square inch gauge; a unit of measure of pressure.

ASME: American Society of Mechanical Engineers; made, tested, inspected and registered to meet the standards of the ASME.

California Code: Unit may comply with California Code 462 (2)(M) (2). Specification/Model Label is on the side of the air tank on units that comply with California Code.

Cut-In Pressure: While the motor is off, air tank pressure drops as you continue to use your accessory. When the air tank pressure drops to a certain low level the motor will restart automatically. The low pressure at which the motor automatically re-starts is called "cut-in pressure."

Cut-Out Pressure: When you turn on your air compressor and it begins to run, air pressure in the air tank begins to build. It builds to a certain high pressure before the motor automatically shuts off - protecting your air tank from pressure higher than its capacity. The high pressure at which the motor shuts off is called "cut-out pressure."

To Lock Out Power: Place a lock on the line power switch so no one else can turn on the power.

DUTY CYCLE

All DeVilbiss Air Power manufactured air compressors should be operated on not more than a 50% duty cycle. This means an air compressor that pumps more than 50% of one hour, is

considered misuse, because the air compressor is undersized for the required air demand. Maximum air compressor pumping time per hour is 30 minutes.

INSTALLATION

Location of the Air Compressor

⚠ WARNING

THE MANIFOLD ASSEMBLY DOES NOT PROVIDE ADEQUATE STABILITY OR SUPPORT FOR LIFTING THE UNIT. IF THE OUTFIT MUST BE MOVED, USE THE AIR TANK FOR LIFTING.

This air compressor should be permanently mounted in a place on a level floor. Operate the air compressor in a clean, dry and well ventilated area. The air intake filter must be kept clear of obstructions which could reduce air delivery of the air compressor.

The air compressor should be located at least 12 inches away from walls or other obstructions that could interfere with the flow of air through the fan bladed flywheel. The air compressor crankcase and head are designed with fins to provide proper cooling.

The flywheel side of the outfit should be placed toward the wall and protected with a totally enclosed belt guard. In no case should the flywheel be closer than 12 to 18 inches from the wall or other obstruction that will interfere with the flow of air through the fan bladed flywheel. The area should allow space on all sides for air circulation and for ease of normal maintenance. Keep the outfit away from areas which have dirt, vapor and volatile fumes in the atmosphere which may clog and gum up the intake filter and valves, causing inefficient operation. Where this is not practical a remote air intake is recommended.

Note

Where a remote air intake is used, enlarge the size of the air intake piping by one pipe size for each 10 feet of length.

INSTALLATION (cont'd)

If humidity is high, an air filter can be installed to remove excessive moisture. Closely follow instructions packaged with the filter for proper installation. It must be installed as close as possible to the accessory.

The air compressor should be as near to air outlets as possible in order to avoid long pipe lines. Do not place the air compressor where heat is excessive.

Do not use an extension cord. To avoid voltage drop and power loss to the motor, use extra air hose instead of an extension cord. Low voltage can cause damage to the motor.

Air Compressor Anchoring Methods

⚠ WARNING

VIBRATION CAN WEAKEN THE AIR TANK AND CAUSE AN EXPLOSION. THE AIR COMPRESSOR MUST BE PROPERLY MOUNTED AS ILLUSTRATED BELOW.

This air compressor must be bolted to the floor. Bolting holes are provided in the base feet. Mount the air compressor on a solid, level foundation. Support air compressor weight evenly on all four feet. Solid shims may be used if necessary.

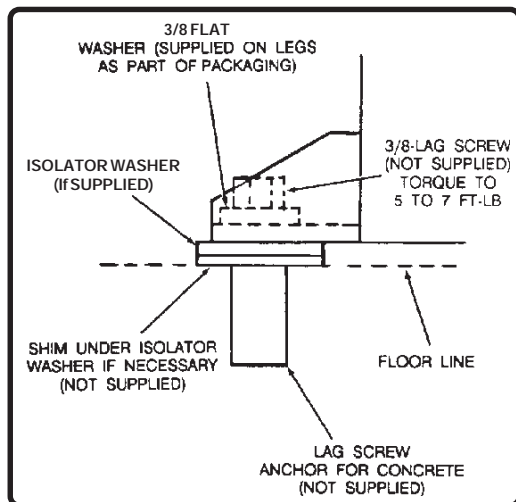

To Install Air Filter (if equipped)

Attach elbow to pump using bolts provided. Tighten until snug. Insert threaded end of air filter assembly into elbow and tighten until snug.

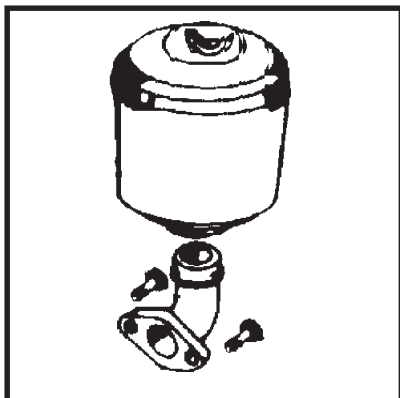

⚠ CAUTION

Do not operate air compressor without air filter assembly installed as this will cause damage to the outfit.

Wiring Instructions

Perform electrical wiring according to the following instructions:

⚠ WARNING

IMPROPER ELECTRICAL GROUNDING CAN RESULT IN A RISK OF ELECTRICAL SHOCK. WIRING FOR THE PRESSURE SWITCH AND ELECTRICAL MOTOR SHOULD BE DONE BY A LICENSED ELECTRICIAN IN ACCORDANCE WITH NATIONAL AND LOCAL CODES AND ORDINANCES.

Install the air compressor outfit as close to the main power supply as possible. This practice will avoid using long lengths of electrical wiring for the power supply which can cause power loss to the motor. When connecting wires make sure that:

1. The amperage rating of the electrical box is adequate.
2. The supply line has the same electrical characteristics (voltage, cycle, and phase) as motor.

Refer to the Specification Chart in the Outfit Parts Manual for your air compressor outfit.

NOTE: THESE OUTFITS DO NOT INCLUDE ANY WIRING BECAUSE OF VARIOUS INSTALLATION REQUIREMENTS.

Wiring must be such that full motor nameplate voltage plus or minus 10%, is available at the motor terminals during starting. Refer to local codes for recommended wire sizes for correct wire size and maximum wire run; undersize wire causes high amp draw and overheating to the motor.

⚠ CAUTION

Electrical wiring must be located away from hot surfaces such as the air compressor head, compressor cylinder, or compressor outlet tube.

Typical Wiring Of Air compressor Units with 60, 80, and 120 Gallons Capacity

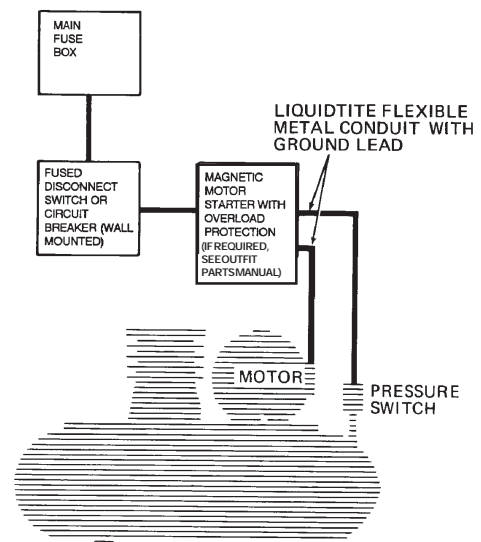

INSTALLATION (cont'd)

Voltage and Circuit Protection

Refer to your Outfit Parts Manual for the voltage and circuit protection requirements of your air compressor. Use only a fuse or circuit breaker that is the same rating as the branch circuit the air compressor is operated on. If the air compressor is connected to a circuit protected by fuses, use only dual element time delay fuses, as noted in the Parts Manual.

*Some two stage air compressors require a magnetic starter. Check the specification chart in the Outfit Parts Manual to see if required or not.

Typical schematic subject to all changes as dictated by local electrical codes and authorities.

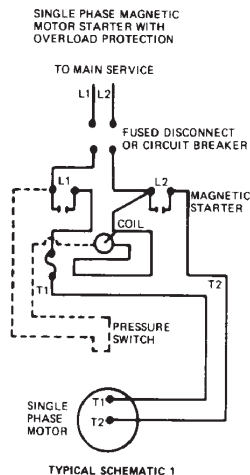

⚠ WARNING

This product should be connected to a grounded, metallic, permanent wiring system, or an equipment-grounding terminal or lead on the product.

GROUNDING INSTRUCTIONS

⚠ WARNING

RISK OF ELECTRICAL SHOCK! In the event of a short circuit, grounding reduces the risk of shock by providing an escape wire for the electric current. This air compressor must be properly grounded.

⚠ DANGER

IMPROPER GROUNDING CAN RESULT IN ELECTRICAL SHOCK! ALL GROUNDING SHOULD BE PERFORMED BY A LICENSED ELECTRICIAN IN ACCORDANCE WITH NATIONAL AND LOCAL ELECTRICAL CODES!

Make certain that the electrical circuit to which the air compressor is connected provides proper electrical grounding, correct voltage and adequate fuse protection. The air compressor can be grounded by the following method:

When hard wiring in an air compressor, use wiring that contains a bare copper grounding wire. This wire must be connected to the pressure switch at the grounding location provided. This is located inside the pressure switch. The other end of the wire must be connected to a ground at the fuse/circuit breaker box in accordance with national and local electrical codes.

If these grounding instructions are not completely understood, or if in doubt as to whether the air compressor is properly grounded, have the installation checked by an Authorized Warranty Service Center or a licensed electrician.

Lubrication and Oil

⚠ CAUTION

Air compressors are shipped without oil. A small amount of oil may be present in the pump upon receipt of the air compressor. This is due to plant testing and does not mean that the pump contains the correct amount of oil. Do not attempt to operate in order to check wiring or for any reason without first adding oil to the crankcase. Serious damage to the pump can result from even very limited use without oil. Fill crankcase with recommended oil before operating.

⚠ CAUTION

Multi-viscosity motor oils like 10W30, should not be used in an air compressor. They leave carbon deposits on critical components, thus reducing performance and air compressor life. Use air compressor oil only.

Remove the oil fill plug and fill the crankcase with recommended oil. Refer to the Service Instructions in this manual for the specific oil recommended for use in your air compressor unit (See page 14). Replace the oil fill plug.

Additional Regulators and Controls

Since the air tank pressure is usually greater than that which is needed, a separate regulator is usually employed to control the air pressure ahead of any individual air driven device.

Separate air transformers that combine the functions of air regulation and moisture and dirt removal should be used where applicable.

INSTALLATION (cont'd)

Piping

CAUTION

Plastic or PVC pipe is not designed for use with compressed air. Regardless of its indicated pressure rating, plastic pipe can burst from air pressure. Use only metal pipe for air distribution lines.

Note

Where a remote air intake is used, enlarge the size of the air intake piping by one pipe size for each 10 feet of length.

A typical compressed air distribution system as shown on this page should be of sufficient pipe size to keep the pressure drop between the supply and point of use to a minimum. All pipes and fittings used must be certified safe for the pressures involved. Pipe thread lubricant must be used on all male pipe threads, and all joints are to be made up tight, since small leaks in the piping system are the largest single cause of high operating costs.

All piping should be sloped to an accessible drain point and all outlets should be taken from the top of the main distribution air line so that moisture cannot enter the outlet.

The main distribution air line should not be smaller than the air compressor discharge valve outlet. A smaller line will restrict the flow of air. If piping is over 100 feet long, or if required air flow will exceed 15 SCFM, use 3/4" piping.

Note

For underground installation, bury air lines below the frost line and avoid pockets where condensation can gather and freeze. Apply pressure before underground lines are covered to make sure all pipe joints are free from leaks.

It is recommended that a flexible coupling be installed between the air discharge valve outlet and main air distribution line to allow for vibration.

To remove dirt, oil, and water, install a separator in the main distribution line. Install separator 5 to 6 feet from air compressor to allow the air to cool to room temperature before passing through the separator. Additional separators or filters may be used depending on the application.

Liquid water occurs naturally in air lines as a result of compression. Moisture vapor in ambient air is concentrated when pressurized and condenses when cooled in downstream air piping.

Compressed air dryers reduce the water vapor concentration and prevent liquid water formation in compressed air lines. Dryers are a necessary companion to filters, aftercoolers, and automatic drains for improving the productivity of compressed air systems.

Water and water vapor removal increases the efficiency of air operated equipment, reduces contamination and rusting, increases the service life of pneumatic equipment and tools, prevents air line freeze-ups, and reduces product rejects. The use of dryers, aftercoolers, and filters are recommended when these moisture related problems are reported to our factory or distributor service department.

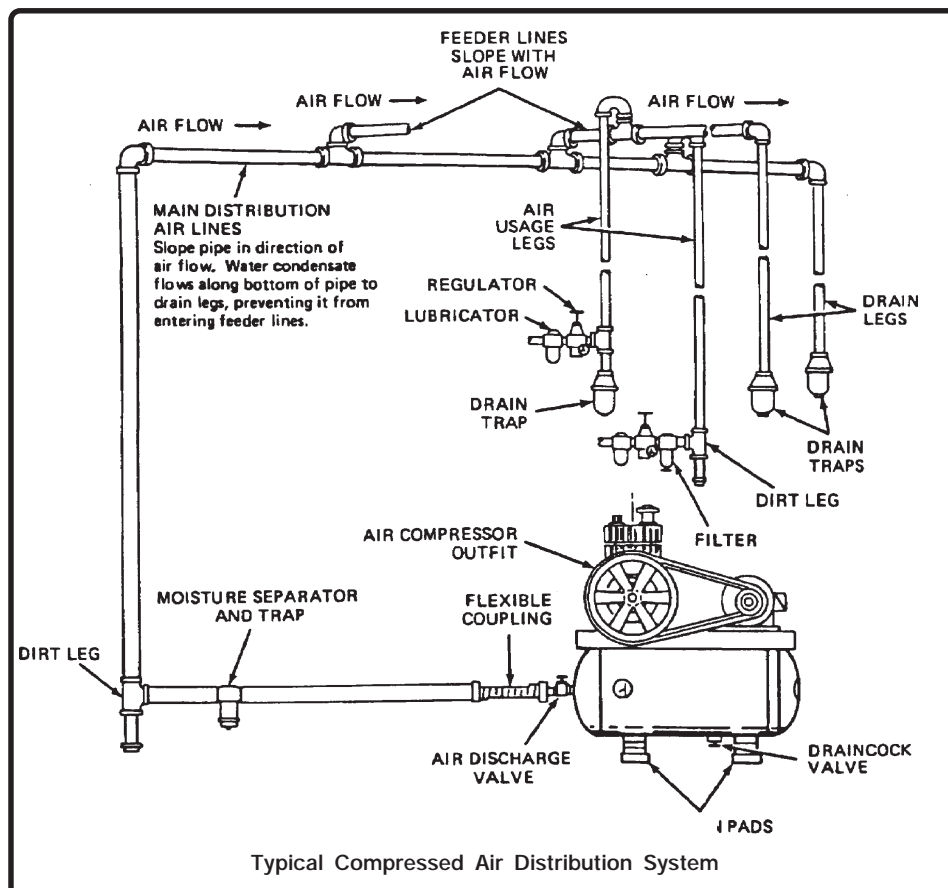

DESCRIPTION OF OPERATION

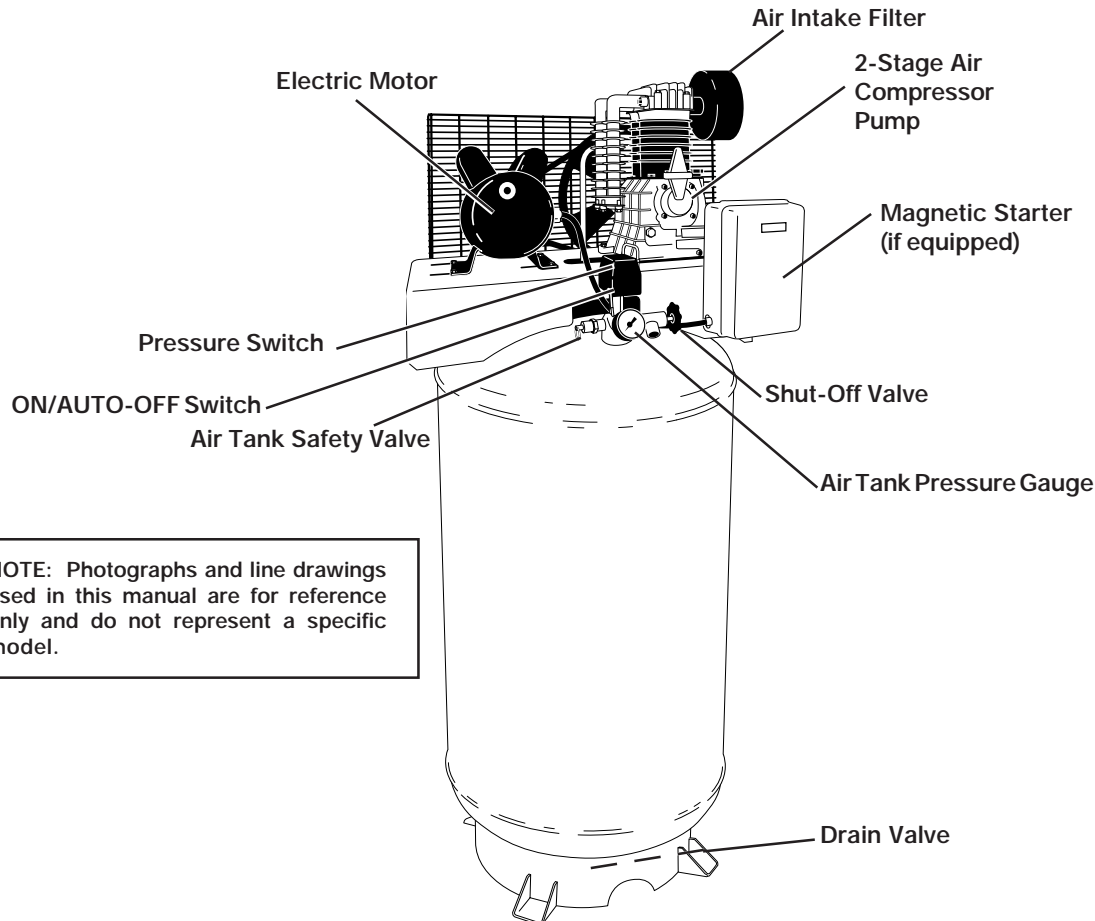

NOTE: Photographs and line drawings used in this manual are for reference only and do not represent a specific model.

Drain Valve: Located at the base of the air tank to drain condensation at the end of each use.

ON/AUTO-OFF Switch: Turn this switch ON to provide automatic power to the pressure switch and OFF to remove power.

Pressure Switch: The pressure switch automatically starts the motor when the air tank pressure drops below the factory set "cut-in" pressure. It stops the motor when the air tank pressure reaches the factory set "cut-out" pressure.

Air Intake Filter: This filter is designed to clean air coming into the pump. This filter must always be clean and ventilation openings free from obstructions. See "Maintenance".

Air Compressor Pump: In two stage air compressors, air is first compressed to an intermediate pressure in the large bore cylinder, and after passing through an intercooler, the air is further compressed to a higher pressure in the smaller bore cylinder. This process continues until the air tank pressure reaches the factory set cutoff pressure. At that point the pressure switch shuts the electric motor off.

Check Valve (not shown): When the air compressor is operating, the check valve is "open", allowing compressed air to enter the air tank. When the air compressor reaches "cut-out" pressure, the check valve "closes", allowing air pressure to remain inside the air tank.

Pressure Release Valve (not shown): The pressure release valve located on the side of the pressure switch, is designed to automatically release compressed air from the compressor

head and the outlet tube when the air compressor reaches "cut-out" pressure or is shut off. If the air is not released, the motor will try to start, but will be unable to. The pressure release valve allows the motor to restart freely. When the motor stops running, air will be heard escaping from the valve for a few seconds. No air should be heard leaking when the motor is running.

Shut-off Valve: Turn the knob counterclockwise to open the valve and clockwise to close. (if equipped)

Air Tank Safety Valve: If the pressure switch does not shut off the air compressor at its cut-out pressure setting, the safety valve will protect against high pressure by "popping off" at its factory set pressure (slightly higher than the pressure switch cut-out setting).

Aftercooler Safety Valve (not shown): On two stage air compressor units, a safety valve is provided to prevent over-pressurization of the aftercooler. The valve will protect the aftercooler by "popping off" at its factory set pressure.

Air Tank Pressure Gauge: The air tank pressure gauge indicates the reserve air pressure in the air tank. On outfits with no pressure regulator, this is also the pressure available at the air outlet.

Regulator (sold separately): An air pressure regulator or a separate air transformer which combines the functions of air regulation and/or moisture and dirt removal is recommended for most applications.

BREAK-IN PROCEDURES

Break-In Procedures

⚠ CAUTION

Serious damage may result if the following break-in instructions are not closely followed.

The Break-In Procedure is required when:

- A. New air compressor is put into service.
 - B. Check valve is replaced
 - C. New pump is installed on air tank.
1. Recheck air compressor wiring. Make sure wires are secure at all terminal connections. Free all contacts of loose wire cuttings, etc.
 2. Position the fuse disconnect or circuit breaker to the ON position and, if equipped, turn the ON/AUTO-OFF switch on the pressure switch to the ON position.
 3. Open the shut-off valve fully to permit air to escape and prevent air pressure build-up in the air tank during the break-in period.

4. Run the air compressor for 30 minutes. Make sure the shut-off valve is open and there is no air tank pressure build-up.
5. Check all air line fittings and connections/piping for air leaks by applying a soap solution. Correct as necessary. Even minor leaks can cause this air compressor to overwork, resulting in premature breakdown or inadequate performance.
6. Check for excessive vibration and noise. Adjust air compressor belt guard as necessary to eliminate chatter. Readjust or shim the air compressor feet, if necessary, for proper level.
7. Close the shut-off valve and let air compressor pump up to "cut-out pressure". Turn the air compressor off and check oil level. Add oil if necessary. Connect air hose to air outlet adapter.

Your air compressor is now ready for use.

OPERATING PROCEDURES

1. Before attaching an air hose or accessory, make sure the shut-off valve is in the closed position. On units equipped with a pressure switch lever make sure the switch is in the OFF position.

⚠ CAUTION

Compressed air from the outfit may contain water condensation and oil mist. Do not spray unfiltered air at an item that could be damaged by moisture. Some air operated tools or devices may require filtered air. Read instructions for air tool or device.

2. Attach regulator, hose and accessory. On models without an air pressure regulator, one must be installed before using accessories rated at less than 175 psig.

⚠ WARNING

TOO MUCH AIR PRESSURE CAUSES A HAZARDOUS RISK OF BURSTING. CHECK THE MANUFACTURER'S MAXIMUM PRESSURE RATING FOR AIR TOOLS AND ACCESSORIES. THE REGULATOR OUTLET PRESSURE MUST NEVER EXCEED THE MAXIMUM PRESSURE RATING.

3. Turn the air compressor ON and allow air tank pressure to build. On units equipped with a pressure switch lever, place the switch in the ON-AUTO position. The motor will stop when air tank pressure reaches "cut-out pressure".
4. Open the shut-off valve.
5. If an air pressure regulator is in use, open the regulator by turning it clockwise. Adjust the regulator to the correct pressure setting. Your outfit is ready for use.

When You Are Finished:

6. Turn the air compressor unit off.
7. Turn the regulator counterclockwise and set the outlet pressure to zero.
8. Remove the air tool or accessory.
9. Open the regulator and allow the air to slowly bleed from the air tank. Close the regulator when air tank pressure is approximately 20 psi.
10. Open the drain valve underneath the air tank and drain water from air tank.

⚠ WARNING

DRAIN AIR TANK DAILY. WATER WILL CONDENSE IN THE AIR TANK. IF NOT DRAINED, THE WATER WILL CORRODE AND WEAKEN THE AIR TANK, CAUSING A RISK OF AIR TANK RUPTURE. THE AIR TANK MUST BE DRAINED PROPERLY.

11. After the water has been drained, close the drain valve.
 - if the air compressor is under continuous use
 - drain at least once each day.
 - if the air compressor is only used occasionally
 - drain after each use.

Operate the unit to 15-20 psig and open the drain cock. Collect the water in a suitable container. Continue operating unit until all moisture is removed from the air tank. Close the drain cock tightly.

Note

If drain cock valve is clogged, release air pressure in air tank. The drain cock valve can then be removed, cleaned and reinstalled.

MAINTENANCE

⚠ WARNING

UNIT CYCLES AUTOMATICALLY WHEN POWER IS ON. DURING MAINTENANCE, YOU COULD BE EXPOSED TO VOLTAGE SOURCES, COMPRESSED AIR OR MOVING PARTS. PERSONAL INJURIES CAN OCCUR. UNPLUG THE UNIT AND BLEED OFF ALL AIR TANK PRESSURE BEFORE DOING ANY MAINTENANCE OR REPAIR. NEVER OPERATE THE UNIT WITH THE BELT GUARD REMOVED.

To ensure efficient operation and longer life of the air compressor outfit, a routine maintenance schedule should be prepared and followed. The following routine maintenance schedule is geared to an outfit in a normal working environment operating on a daily basis. If necessary, the schedule should be modified to suit the conditions under which your air compressor is used. The modifications will depend upon the hours of operation and the working environment. Air compressor outfits in an extremely dirty and/or hostile environment will require a greater frequency of all maintenance checks.

A clean air compressor runs cooler and provides longer service. Clean or blow off fins and any other parts of the air compressor that collect dust or dirt. Do not place rags, containers or other material on or against the ventilation openings in the belt guard. Adequate ventilation is necessary to maintain proper air compressor operating temperature.

Routine Maintenance Schedule

IMPORTANT: See the Parts Manual to determine your air compressor pump type. If the air compressor pump type is Shultz, see the Parts Manual for Maintenance information.

Every 8 Hours of Operation

1. Check oil level. Add if necessary.
2. Drain water from the air tank, any moisture separators or transformers.

⚠ CAUTION

Overfilling with oil will cause premature air compressor pump failure. Do not overfill.

3. Check for any unusual noise and/or vibration.
4. Manually check all safety valves to make sure they are operating properly.
5. Inspect for oil leaks and repair any leaks found.
6. Check air filter.

Every 40 Hours of Operation

1. Clean and inspect the air intake filter; replace if necessary.
2. Inspect condition of drive belt; replace if necessary.

Every 100 Hours of Operation

1. Drain and refill air compressor crankcase with clean oil. Refer to Service Instructions for recommended oils.
2. Increase frequency of oil changes if humidity or operating conditions are extreme.

Every 160 Hours of Operation

1. Check drive belt tension; adjust if necessary. (Refer to SERVICE INSTRUCTIONS in this manual.)
2. Inspect air lines and fittings for leaks; correct as necessary.
3. Check the alignment of the motor pulley to the flywheel. If necessary, align to within 1/32 inch on centerline.

Every 500 Hours of Operation

1. Drain and refill air compressor crankcase with clean oil. Refer to Service Instructions for recommended oils.
2. Increase frequency of oil changes if humidity or operating conditions are extreme.

Each Year of Operation (2000 Hours or if a Problem is Suspected)

Check condition of air compressor pump intake and exhaust valves. Replace if damaged or worn out. (Refer to the Outfit Parts Manual.)

SERVICE INSTRUCTIONS

Air Filter - Inspection and Replacement

NOTE

Keep the air filter clean at all times. Do not operate the air compressor with the air filter removed.

A dirty air filter will not allow the air compressor to operate at full capacity. Before you use the air compressor, check the air filter to be sure it is clean.

If it is dirty, replace it with a new filter.

Oil - Checking and Changing

CAUTION

Overfilling with oil will cause premature air compressor pump failure. Do not overfill.

1. Check oil level in air compressor crankcase before each use. The oil level should be to the middle of the oil sight glass.
2. See **Routine Maintenance Schedule for oil change scheduling.**
3. Remove the oil fill and drain plugs. Collect the oil in a suitable container.
4. Replace the oil drain plug and refill the crankcase with recommended oil.

Note

It is important to maintain the proper oil level. A low oil level reduces proper cylinder wall lubrication and increases ring wear.

5. Replace the oil fill plug.
6. Start the air compressor outfit and run for several minutes. Shut the air compressor down and check the oil level. If necessary, add more oil.

Viscosity Chart

For ABP-4900 AND ABP-459

Recommended Oil (API SG/CD Heavy Duty)*	Room or Ambient Temperature
SAE 20 SAE 30	Below 20°F Above 32°F

For BAL-T59S AND BAL-T39

Recommended Oil (API SG/CD Heavy Duty)*	Room or Ambient Temperature
SAE 20 SAE 30	Cold Climates - 10° F Moderate Climates - 30° to 80° F
SAE 40	Hot Climates - 80° F

Oil Type

An air compressor grade **non-detergent** oil should be used. Most automotive detergent oils cause excessive carbon buildup and should not be used. Please note that all units run at a constant speed (not start and stop) and should be lubricated by Rarus 847, Shell turbo 100, or Anderol synthetic air compressor oil. **Do not** use synthetic oil for the first 300 hours. All units should be broken in on petroleum based oil.

* *DeVilbiss Brand AC240 can also be used in this air compressor.*

Oil Capacity

Air compressor Pump	*Fluid Ounces of Oil
ABP-4900	42 oz.
ABP-459	60 oz.
BAL-T59S	58 oz.
BAL-T39	40 oz.
SHULTZ	16 oz.

* *Oil capacities above are approximations. Always fill to middle of sight glass. Refer to parts manual for pump identification.*

Check Valve - Inspection and Replacement

Remove and inspect the check valve at least once a year or more often if the air compressor is heavily used. Moisture and other contaminants in the hot compressed air will cause an accumulation of a carbon-like residue on the working parts. If the valve has heavy carbon build-up, it should be replaced. Use the following procedure to inspect, clean or replace the check valve.

1. Turn air compressor off and disconnect or lock out power source.
2. Release air pressure from the air tank.
3. Loosen the top and bottom tube nuts and remove the outlet tube.
4. Remove pressure release tube.
5. Unscrew the check valve (turn counterclockwise) using socket wrench.
6. Check that the valve disc moves freely and that the spring holds the disc in the upper, closed position. The check valve may be cleaned with a solvent.
7. Apply sealant to the check valve threads. Reinstall the check valve (turn clockwise). Do not overtighten.
8. Replace the outlet tube and tighten top and bottom nuts.
9. Replace pressure release tube.

SERVICE INSTRUCTIONS (cont'd)

Safety Valve - Inspection and Replacement

⚠ WARNING

IF THE SAFETY VALVE DOES NOT WORK PROPERLY, OVER-PRESSURIZATION MAY OCCUR CAUSING AIR TANK RUPTURE OR EXPLOSION. OCCASIONALLY PULL THE RING ON THE SAFETY VALVE TO MAKE SURE THAT THE SAFETY VALVE OPERATES FREELY. IF THE VALVE IS STUCK OR DOES NOT OPERATE SMOOTHLY, IT MUST BE REPLACED WITH A VALVE HAVING THE SAME PRESSURE RATING.

1. Remove and lock out power from the air compressor. Release any air pressure from the air tank.
2. Remove safety valve and replace with valve of the same pressure rating.
3. Apply thread sealant to new safety valve and tighten. **DO NOT OVERTIGHTEN.**



Belt - Replacement

(Refer to the Outfit Parts Manual for replacement belt part number.)

⚠ WARNING

SERIOUS INJURY OR DAMAGE MAY OCCUR IF PARTS OF THE BODY OR LOOSE ITEMS GET CAUGHT IN MOVING PARTS. NEVER OPERATE THE OUTFIT WITH THE BELT GUARD REMOVED. THE BELT GUARD SHOULD BE REMOVED ONLY WHEN THE AIR COMPRESSOR POWER IS DISCONNECTED.

1. Turn air compressor off, lock out the power supply, and relieve all air pressure from the air tank.
2. Remove the clips, screws, and outer panel of belt guard.
3. Loosen the motor mounting hardware and slide the motor toward the air compressor.
4. Remove the belt and replace with a new one.

Adjusting Belt Tension

Adjust belt tension as described below:

1. Slide motor away from air compressor until desired tension is obtained.
The belt should deflect 3/16" at midway between the pulley and the flywheel when a 5 pound weight is applied at the midway point.
2. Tighten two outside cap screws enough to hold the motor in place for checking pulley and flywheel alignment.
3. Once aligned, tighten all four cap screws. See Outfit Parts Manual for correct torque specifications.

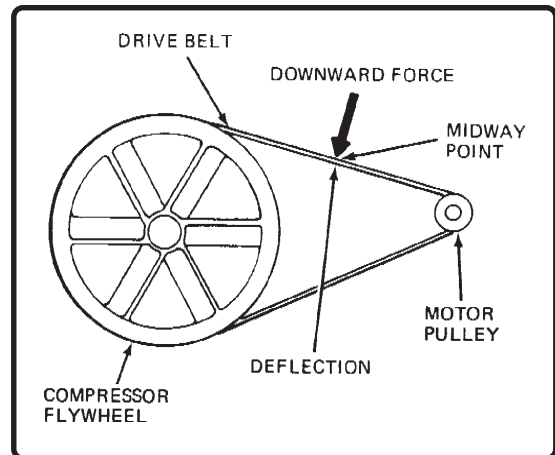

Motor Pulley and Flywheel Alignment

1. Place a straight edge along the outside face of the air compressor flywheel to check alignment of V-belt grooves. (See figure below for proper alignment.)
2. If the belt grooves aren't aligned, continue with step 3 of this procedure. If the belt grooves are aligned, continue with step 4 of this procedure.
3. Loosen pulley set screw and move the pulley until it is in proper alignment.
4. Tighten pulley set screw. See Outfit Parts Manual for correct torque specifications.
5. Reinstall belt guard.

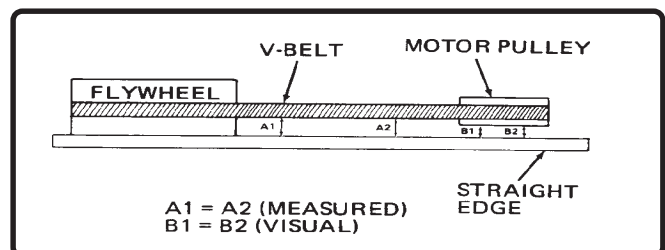

SERVICE INSTRUCTIONS (cont'd)

Motor Overload Protector - Reset

The electric motor has a thermal overload protector (Models with a magnetic starter will not). If the motor overheats for any reason, the thermal overload protector will shut off the motor. The motor must be allowed to cool down before restarting.

If equipped with an ON/AUTO-OFF pressure switch, restart as follows:

1. Turn the ON/AUTO-OFF switch to the OFF position.
2. Depress the reset button located on the end of the electrical motor.
3. To restart the motor, turn the ON/AUTO-OFF switch to the ON/AUTO position.

If not equipped with an ON/AUTO-OFF pressure switch, restart as follows:

1. Position the fuse disconnect or circuit breaker to the OFF position.
2. Depress the reset button located on the end of the electrical motor.

Note

If the thermal overload protector shuts the motor off frequently, check for possible voltage problems. Low voltage can also be suspected when:

1. The motor does not get up to full power or speed.
2. Fuses blow out when starting the motor.
3. Lights dim and remain dim when motor is started.

Motor Lubrication

Follow the manufacturer's recommendations that are attached to your motor.

Air compressor Head Bolts - Torquing

The air compressor pump head bolts should be kept properly torqued. Check the torques of the head bolts after the first five hours of operation. Retighten if necessary. See Outfit Parts manual for torque specifications.

Additional Service

Disassembly or service of the air compressor beyond what is covered in this manual is not recommended. If additional service is required, contact your nearest Authorized Warranty Service Center.

STORAGE OF COMPRESSOR OUTFIT

1. Review the Maintenance section on the preceding pages and perform scheduled maintenance as necessary. Drain the water from the air tank.
2. Turn air compressor off and disconnect or lock out power source.
3. Remove any air tool or accessory.
4. Protect the electrical cord and/or air hose from damage (such as being stepped on or run over).
5. Store the air compressor in a clean and dry location.

TROUBLESHOOTING GUIDE

⚠ WARNING

PERFORMING REPAIRS MAY EXPOSE VOLTAGE SOURCES, MOVING PARTS OR COMPRESSED AIR SOURCES. PERSONAL INJURY MAY OCCUR. PRIOR TO ATTEMPTING ANY REPAIRS, UNPLUG THE AIR COMPRESSOR AND BLEED OFF ALL AIR TANK AIR PRESSURE.

PROBLEM	CAUSE	CORRECTION
Excessive air tank pressure - safety valve pops off (units with ON-AUTO switch).	Pressure switch does not shut off motor when air compressor reaches "cut-out" pressure. Pressure switch "cut-out" too high.	Move the pressure switch lever to the "OFF" position. If the outfit doesn't shut off. If the electrical contacts are welded together, replace the pressure switch. Contact a Service Center to check and adjust, or replace switch.
Excessive air tank pressure - safety valve pops off (units with ON-AUTO switch).	Pressure switch does not shut off motor when air compressor reaches "cut-out pressure".	Pressure switch must be replaced.
Air leaks at fittings or hose.	Tube fittings are not tight enough.	Tighten fittings where air can be heard escaping. Check fittings with soapy water solution. DO NOT OVER-TIGHTEN.
Air leaks at or inside check valve.	Defective or dirty check valve.	A defective check valve results in a constant air leak at the pressure release valve when there is pressure in the air tank and the air compressor is shut off. Remove and clean or replace check valve. DO NOT OVER-TIGHTEN.
Air leaks at pressure switch release valve during running.	Defective pressure switch release valve.	Remove and replace the release valve.
Continuous air relieving from pressure switch release valve after shut off.	Defective check valve.	Replace check valve.
Air leaks in air tank or at air tank welds.	Defective air tank.	Air tank must be replaced. ⚠ WARNING DO NOT DRILL INTO, WELD, OR OTHERWISE MODIFY AIR TANK. IT WILL WEAKEN. THE AIR TANK CAN RUPTURE OR EXPLODE.
Air leak from safety valves.	Possible defect in safety valves.	Operate safety valves manually by pulling on ring. If a valve still leaks, it should be replaced.
Squealing sound.	Loose belt. There is no oil in the air compressor.	Adjust belt tension. (See Belt Replacement.) Add oil.

TROUBLESHOOTING GUIDE (cont'd)

PROBLEM	CAUSE	CORRECTION
Motor will not run.	<p>Motor overload protection switch has tripped.</p> <p>Air tank pressure exceeds pressure switch "cut-in pressure".</p> <p>Check valve stuck open.</p> <p>Loose electrical connections.</p> <p>Possible defective capacitor.</p> <p>Paint spray on internal motor parts.</p> <p>Possible defective motor.</p> <p>Fuse blown, circuit breaker tripped.</p> <p>Pressure release valve on pressure switch has not unloaded head pressure.</p>	<p>Let motor cool off and reset switch by pressing the red button located on the end of the motor. If the overload still trips, check for defective capacitor or wrong voltage.</p> <p>Motor will start automatically when air tank pressure drops below "cut-in pressure" of pressure switch.</p> <p>Remove and clean or replace. DO NOT OVERTIGHTEN.</p> <p>Check wiring connection inside pressure switch and motor terminal box area.</p> <p>Contact Service Center for inspection or replacement if necessary.</p> <p>Have checked by a Service Center. Do not operate the air compressor in the spray area. See Flammable Vapor Warning.</p> <p>Have checked by a local Service Center.</p> <ol style="list-style-type: none"> 1. Check fuse box for blown fuse and replace if necessary. Reset circuit breaker. Do not use a fuse or circuit breaker with higher rating than that specified for your particular branch circuit. 2. Check for proper fuse; only dual element time delay fuses are acceptable. Use a time delay fuse. 3. Check for low voltage conditions and/or proper extension cord. 4. Remove check valve and clean or replace if it is stuck open or closed. 5. Disconnect the other electrical appliances from circuit or operate the air compressor on its own branch circuit. <p>On an ON/AUTO pressure switch equipped with a pressure relief valve, bleed the line by pushing the pressure switch to the OFF position. If valve does not open, bend the lever until it does. If valve still fails to bleed, replace the valve assembly.</p>
Excessive belt wear.	<p>Loose belt/tight belt.</p> <p>Loose pulley.</p>	<p>Adjust belt tension. (See Belt Replacement.)</p> <p>Check for worn keyway or pulley bore. Also check for bent motor shaft. Replace parts if necessary. (Refer to the Outfit Parts Manual.)</p>
Air compressor is not supplying enough air to operate accessories.	<p>Prolonged excessive use of air.</p> <p>Air compressor is not large enough for air requirement.</p> <p>Restricted air intake filter.</p> <p>Loose belt.</p>	<p>Decrease amount of air usage.</p> <p>Check the accessory air requirement. If it is higher than the CFM or pressure supplied by your air compressor, you need a larger air compressor.</p> <p>Clean or replace air intake filter. Do not operate the air compressor in the paint spray area.</p> <p>Adjust belt tension.</p>

TROUBLESHOOTING GUIDE (cont'd)

PROBLEM	CAUSE	CORRECTION
Air compressor is not supplying enough air to operate accessories. <i>(Continued)</i>	<p>Hole in hose.</p> <p>Check valve restricted.</p> <p>Air leaks.</p>	<p>Check and replace if required.</p> <p>Remove and clean or replace.</p> <p>Tighten fittings. (See "Air Leaks" section of "Troubleshooting Guide".)</p>
Knocking noise.	<p>Defective check valve.</p> <p>Loose pulley.</p> <p>Low oil level.</p> <p>Loose flywheel.</p> <p>Loosen air compressor mounting screws.</p> <p>Belt too tight/too loose.</p> <p>Carbon build-up.</p>	<p>Remove and clean or replace.</p> <p>Tighten pulley set screw. See Outfit Parts Manual for correct torque specifications.</p> <p>Maintain prescribed oil level. Add oil.</p> <p>Tighten screw. See Outfit Parts Manual for correct torque specifications.</p> <p>Check screws. Tighten as required.</p> <p>Adjust belt tension. (See Belt Replacement.)</p> <p>Remove the head and valve plate. Clean the valve plate and the top of the piston. (Be sure carbon does not fall into the cylinder.) Reassemble using new gaskets and see Outfit Parts Manual for correct torque specifications.</p>
Excessive oil consumption.	<p>Restricted air intake.</p> <p>Air compressor overworked.</p> <p>Poor quality oil.</p>	<p>Replace the air intake.</p> <p>Reduce air consumption or add another air compressor to take up some of the load.</p> <p>Drain pump and replace with correct oil. Refer to Lubrication and Oil Section.</p>
Air compressor overheating.	<p>Air compressor overworked.</p> <p>The outlet tube and/or check valve is restricted.</p> <p>Dirty air compressor.</p> <p>High ambient temperature.</p>	<p>Reduce air consumption or add another air compressor to take up some of the load.</p> <p>Check the tube and the check valve. Clean if necessary.</p> <p>Clean the air compressor thoroughly.</p> <p>Use remote air intake.</p>
Motor overheating.	<p>Incorrect oil, low oil.</p> <p>Low voltage.</p> <p>Pressure switch set beyond factory setting.</p> <p>Belt too tight.</p> <p>Air compressor valves have excessive carbon deposits build-up; restricted check valve.</p>	<p>See oil recommendation on page 14.</p> <p>Provide correct voltage. Consult local power company or electrician.</p> <p>Do not set switch beyond maximum for which outfit was designed as noted on nameplate.</p> <p>Adjust for proper tension.</p> <p>Clean or replace air compressor valves or check valve.</p>

TROUBLESHOOTING GUIDE (cont'd)

PROBLEM	CAUSE	CORRECTION
Motor overheating. (Continued)	Too many motor starts per hour. Improper wiring gauge. Incorrect voltage.	Consult Service Center. Check electrical hookup and installation data or consult electrician. <p style="text-align: center;">NOTE</p> Current style electric motors run relatively hot under normal operating conditions, with reasonable air compressor loading. This condition is normal and no adjustment is necessary. Under normal operating conditions, the motor amperage draw will not exceed the nameplate amperage rating, plus the service factor, as it appears on the electric motor. If a condition of sustained high amperage exists, refer to service checks above and/or consult electrician. If cause cannot be isolated by an electrician, consult with Service Center for additional assistance.
Water in pump crankcase; oil appears milky in color.	Humid operating conditions. Unit not reaching proper operating temperature because the air compressor runs infrequently and is oversized for the air requirement.	Relocate air compressor outfit, or change oil frequently. Consult Service Center.
Liquid water or moisture in air lines.	Condensation forms in air lines when the warm compressed air coming from the air tank starts to cool down as it travels through the air lines.	Install compressed air dryer sized for the flow and dryness level required.

SERVICE NOTES

SERVICE NOTES

SERVICE NOTES

ACCESSORIES

Accessories can be found at the store the unit was purchased or at a local hardware store.

FILTERS, REGULATORS, LUBRICATORS

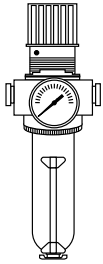

FILTER/ REGULATOR

Regulates air pressure and removes moisture, oil and other debris from the air line. Protects tools from rust and is essential when spray painting. Locate as close to the tool as possible.

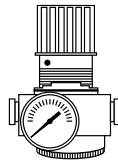

REGULATOR

Controls air pressure downstream and/or in secondary feeder lines.

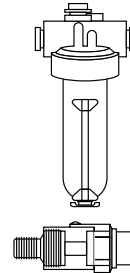

LUBRICATOR OR INLINE OILER

Administers oil into the air line. Reduces excessive wear and rusting in tools. Do not use when spray painting.

PLUMBING COMPONENTS

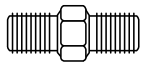

CONNECTORS

Connects components that have similar NPT threads; Male or Female.

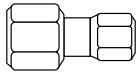

ADAPTERS

Combines components that have different NPT threads; Male or Female.

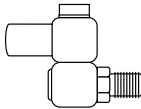

360° SWIVEL CONNECTOR

Eliminates hose twist and improves tool handling.

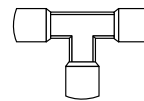

T-FITTING

Ideal for branching air lines.

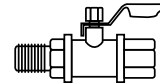

INLINE VALVE

On/Off valve. Controls air flow; not air pressure.

HOSE

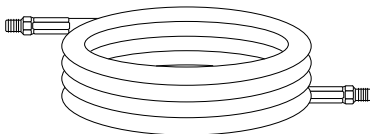

3/8" I.D. HOSE

Ideal for increasing working distance in high CFM applications.

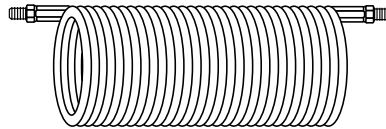

1/4" COIL HOSE

Self-retracting and lightweight. Less bulk than regular hoses. Ideal secondary hose line in lower CFM applications.

QUICK-CONNECTS



BODIES & PLUGS

Together they provide quick and easy attachment/separation of components within the air line. Do not mix different styles of bodies/plugs.

Free Manuals Download Website

<http://myh66.com>

<http://usermanuals.us>

<http://www.somanuals.com>

<http://www.4manuals.cc>

<http://www.manual-lib.com>

<http://www.404manual.com>

<http://www.luxmanual.com>

<http://aubethermostatmanual.com>

Golf course search by state

<http://golfingnear.com>

Email search by domain

<http://emailbydomain.com>

Auto manuals search

<http://auto.somanuals.com>

TV manuals search

<http://tv.somanuals.com>