

Application Note 50

Implementing the RC5050 and RC5051 DC-DC Converters on Pentium® Pro Motherboards

Introduction

This document describes how to implement a switching voltage regulator using an RC5050 or an RC5051 high speed controller, a power inductor, a Schottky diode, appropriate capacitors, and external power MOSFETs. This regulator forms a step down DC-DC converter that can deliver up to 14.5A of continuous load current at voltages ranging from 1.3V to 3.5V. A specific application circuit, design considerations, component selection, PCB layout guidelines, and performance evaluations are covered in detail.

In the past 10 years, microprocessors have evolved at such an exponential rate that a modern chip can rival the computing power of a mainframe computer. Such evolution has been possible because of the increasing numbers of transistors that processors integrate. Pentium CPUs, for example, integrate well over 5 million transistors on a single piece of silicon.

To integrate so many transistors on a piece of silicon, their physical geometry has been reduced to the sub-micron level. As a result of each geometry reduction, the corresponding operational voltage for each transistor has also been reduced. The changing CPU voltage demands the design of a programmable power supply—a design that is not completely re-engineered with every change in CPU voltage.

The voltage range of the CPU has shown a downwards trend for the past 5 years: from 3.3V for the Pentium, to 3.1V for the Pentium Pro, and to 1.8V for future processors. With this trend in mind, Raytheon Electronics has designed the RC5050 and RC5051 controllers. These controllers integrate the necessary programmability to address the changing power supply requirements of lower voltage CPUs.

Previous generations of DC-DC converter controllers were designed with fixed output voltages adjustable only with a set of external resistors. In a high volume production environment (such as with personal computers), however, a CPU voltage change requires a CPU board re-design to accommodate the new voltage requirement. The 5-bit DAC in the RC5050 and the RC5051 reads the voltage ID code that is programmed into modern processors and provides the appropriate CPU voltage. In this manner, the PC board does not have to be re-designed each time the CPU voltage changes. The CPU can thus automatically configure its own required supply voltage.

Intel Pentium Pro Processor Power Requirements

Refer to Intel's AP-523 Application Note, *Pentium® Pro Processor Power Distribution Guidelines*, November 1995 (order number 242764-001), as a basic reference. The specifications contained in this document have been modified slightly from the original Intel document to include updated specifications for more recent processors. Please contact Intel Corporation for specific details.

Input Voltages

Available inputs are +12V ±5% and +5V ±5%. Either one or both of these inputs can be used by the DC-DC converter. The input voltage requirements for Raytheon's RC5050 and RC5051 DC-DC converters are listed in Table 1.

Table 1. Input Voltage Requirements

| Part # | Vcc for IC | MOSFET Drain | MOSFET Gate Bias |
|------------------|------------|--------------|-----------------------|
| RC5050 RC5051 | +5V ±5% | +5V ±5% | 12V ±5% or +5V ±5% |

Pentium Pro DC Power Requirements

Refer to Table 2, Intel Pentium Pro and OverDrive® Processor Power Specifications. For a motherboard designs without a standard VRM (Voltage Regulator Module) socket, the on-board DC-DC converter must supply a minimum of 13.9A of current @2.5V and 12.4A of current @3.3V. For a Flexible Motherboard design, the on-board DC-DC converter must supply 14.5A maximum I_{CCP}.

DC Voltage Regulation

As indicated in Table 2, the voltage level supplied to the CPU must be within ±5% of its nominal setting. Voltage regulation limits must include:

- Output load ranges specified in Table 2
- Output ripple/noise
- DC output initial voltage set point
- Temperature and warm up drift (Ambient +10°C to +50°C at full load with a maximum rate of change of 5°C per 10 minutes minimum but no more than 10°C per hour)
- Output load transient with:
 - Slew rate >30A/μs at converter pins
 - Range: 0.3A - I_{CCP} Max (as defined in Table 2).

Table 2. Intel Pentium Pro and OverDrive® Processor Power Specifications

| CPU Model, Features | Voltage Specification, V_{CCP} (VDC) | Maximum Current, I_{CCP} (A) | Maximum Thermal Design power ¹ (W) |
|-----------------------------------|--|--------------------------------|---|
| 150MHz, 256K L2 Cache | 3.1 ±5% | 9.9 | 29.2 |
| 166MHz, 512K L2 Cache | 3.3 ±5% | 11.2 | 35.0 |
| 180MHz, 256K L2 Cache | 3.3 ±5% | 10.1 | 31.7 |
| 200MHz, 256K L2 Cache | 3.3 ±5% | 11.2 | 35.0 |
| 200MHz, 512K L2 Cache | 3.3 ±5% | 12.4 | 37.9 |
| OverDrive Processors | | | |
| 150Mhz | 2.5 ±5% | 11.2 | 26.7 |
| 180Mhz | | 12.5 | 29.7 |
| 200Mhz | | 13.9 | 32.9 |
| Flexible Motherboard ² | 2.4-3.5 ±5% | 14.5 | 45.0 |

Notes:

- Maximum power values are measured at typical V_{CCP} to take into account the thermal time constant of the CPU package.
- Flexible motherboard specifications are recommendations only. Actual specifications are subject to change.

Output Ripple and Noise

Ripple and noise are defined as periodic or random signals over the frequency band of 20Mhz at the output pins. Output ripple and noise requirements of ±13mV must be met throughout the full load range and under all specified input voltage conditions.

Efficiency

The efficiency of the DC-DC converter must be greater than 80% at maximum output current and greater than 40% at low current draw.

Processor Voltage Identification

There are four voltage identification Pins, VID3-VID0, on the Pentium Pro processor package which can be used to support automatic selection of the power supply voltage. These pins are internally unconnected or are shorted to ground (V_{SS}). The logic status of the VID pins defines the voltage required by the processor. In order to address future low voltage microprocessors, the RC5050 and RC5051 include a VID4 input bit to extend the output voltage range as low as 1.3V. The output voltage programming codes are presented in Table 3. A "1" refers to an open pin and a "0" refers to a short to ground.

Table 3. Output Voltage Programming Codes

| VID4 | VID3 | VID2 | VID1 | VID0 | V_{OUT} to CPU |
|------|------|------|------|------|------------------|
| 0 | 1 | 1 | 1 | 1 | 1.30V |
| 0 | 1 | 1 | 1 | 0 | 1.35V |
| 0 | 1 | 1 | 0 | 1 | 1.40V |
| 0 | 1 | 1 | 0 | 0 | 1.45V |
| 0 | 1 | 0 | 1 | 1 | 1.50V |
| 0 | 1 | 0 | 1 | 0 | 1.55V |

Table 3. Output Voltage Programming Codes (continued)

| VID4 | VID3 | VID2 | VID1 | VID0 | V_{OUT} to CPU |
|------|------|------|------|------|------------------|
| 0 | 1 | 0 | 0 | 1 | 1.60V |
| 0 | 1 | 0 | 0 | 0 | 1.65V |
| 0 | 0 | 1 | 1 | 1 | 1.70V |
| 0 | 0 | 1 | 1 | 0 | 1.75V |
| 0 | 0 | 1 | 0 | 1 | 1.80V |
| 0 | 0 | 1 | 0 | 0 | 1.85V |
| 0 | 0 | 0 | 1 | 1 | 1.90V |
| 0 | 0 | 0 | 1 | 0 | 1.95V |
| 0 | 0 | 0 | 0 | 1 | 2.00V |
| 0 | 0 | 0 | 0 | 0 | 2.05V |
| 1 | 1 | 1 | 1 | 1 | No CPU |
| 1 | 1 | 1 | 1 | 0 | 2.1V |
| 1 | 1 | 1 | 0 | 1 | 2.2V |
| 1 | 1 | 1 | 0 | 0 | 2.3V |
| 1 | 1 | 0 | 1 | 1 | 2.4V |
| 1 | 1 | 0 | 1 | 0 | 2.5V |
| 1 | 1 | 0 | 0 | 1 | 2.6V |
| 1 | 1 | 0 | 0 | 0 | 2.7V |
| 1 | 0 | 1 | 1 | 1 | 2.8V |
| 1 | 0 | 1 | 1 | 0 | 2.9V |
| 1 | 0 | 1 | 0 | 1 | 3.0V |
| 1 | 0 | 1 | 0 | 0 | 3.1V |
| 1 | 0 | 0 | 1 | 1 | 3.2V |
| 1 | 0 | 0 | 1 | 0 | 3.3V |
| 1 | 0 | 0 | 0 | 1 | 3.4V |
| 1 | 0 | 0 | 0 | 0 | 3.5V |

Note:

- 0 = processor pin is tied to GND
1 = processor pin is open.

I/O Controls

In addition to the Voltage Identification, there are several signals that control the DC-DC converter or provide feedback from the DC-DC converter to the CPU. They are Power-Good (PWRGD), Output Enable (OUTEN), and Upgrade Present (UP#). These signals will be discussed later.

RC5050 and RC5051 Description

Simple Step-Down Converter

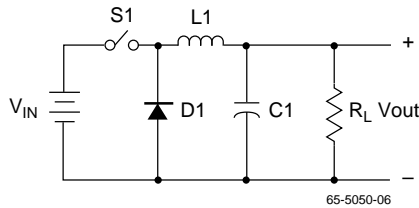

Figure 1. Simple Buck DC-DC Converter

Figure 1 illustrates a step-down DC-DC converter with no feedback control. The derivation of the basic step-down converter is the basis for the design equations for the RC5050 and RC5051. Referring to Figure 1, the basic operation begins by closing the switch S1. When S1 is closed, the input voltage V_{IN} is impressed across inductor L1. The current flowing in this inductor is given by the following equation:

$$I_L = \frac{(V_{IN} - V_{OUT})T_{ON}}{L1}$$

where T_{ON} is the duty cycle (the time when S1 is closed).

When S1 opens, the diode D1 conducts the inductor current and the output current is delivered to the load according to the following equation:

$$I_L = \frac{V_{OUT}(T_S - T_{ON})}{L1}$$

where T_S is the overall switching period and $(T_S - T_{ON})$ is the time during which S1 is open.

By solving these two equations, we can arrive at the basic relationship for the output voltage of a step-down converter:

$$V_{OUT} = V_{IN} \left(\frac{T_{ON}}{T_S} \right)$$

In order to obtain a more accurate approximation for V_{OUT} , we must also include the forward voltage V_D across diode D1 and the switching loss, V_{SW} . After taking into account these factors, the new relationship becomes:

$$V_{OUT} = (V_{IN} + V_D - V_{SW}) \frac{T_{ON}}{T_S} - V_D$$

where V_{SW} = MOSFET switching loss
 $= I_L \cdot R_{DS,ON}$

The RC5050 and RC5051 Controllers

The RC5050 is a programmable non-synchronous DC-DC controller IC. The RC5051 is a synchronous version of the RC5050. When designed around the appropriate external components, either of these devices can be configured to deliver more than 14.5A of output current. The RC5050 and RC5051 utilize both current-mode and voltage-mode PWM control to create an integrated step-down voltage regulator. The key differences between the RC5050 and RC5051 are listed in Table 4.

Table 4. RC5050 and RC5051 Differences

| | RC5051 | RC5050 |
|-----------------------|-------------|-----------------|
| Operation | Synchronous | Non-Synchronous |
| Package | 20-SOIC | 20-SOIC |
| Output Enable/Disable | Yes | Yes |

Main Control Loop

Refer to the RC5051 Block Diagram illustrated in Figure 2. The control loop of the regulator contains two main sections; the analog control block and the digital control block. The analog section consists of signal conditioning amplifiers feeding into a set of comparators which provide the inputs to the digital control block. The signal conditioning section accepts inputs from the IFB (current feedback) and VFB (voltage feedback) pins and sets up two controlling signal paths. The voltage control path amplifies the VFB signal and presents the output to one of the summing amplifier inputs. The current control path takes the difference between the IFB and VFB pins and presents the resulting signal to another input of the summing amplifier. These two signals are then summed together with the slope compensation input from the oscillator. This output is then presented to a comparator, which provides the main PWM control signal to the digital control block.

The additional comparators in the analog control section set the point at which the current limit comparator disables the output drive signals to the external power MOSFETs.

The digital control block takes the comparator inputs and the main clock signal from the oscillator to provide the appropriate pulses to the HIDRV and LODRV output pins. These pins control the external power MOSFETs. The digital section utilizes high speed Schottky transistor logic, allowing the RC5050 and the RC5051 to operate at clock speeds as high as 1MHz.

High Current Output Drivers

The RC5051 contains two identical high current output drivers that utilize high speed bipolar transistors in a push-pull configuration. Each driver is capable of delivering 1A of current in less than 100ns. Each driver's power and ground are separated from the chip's power and ground for additional switching noise immunity.

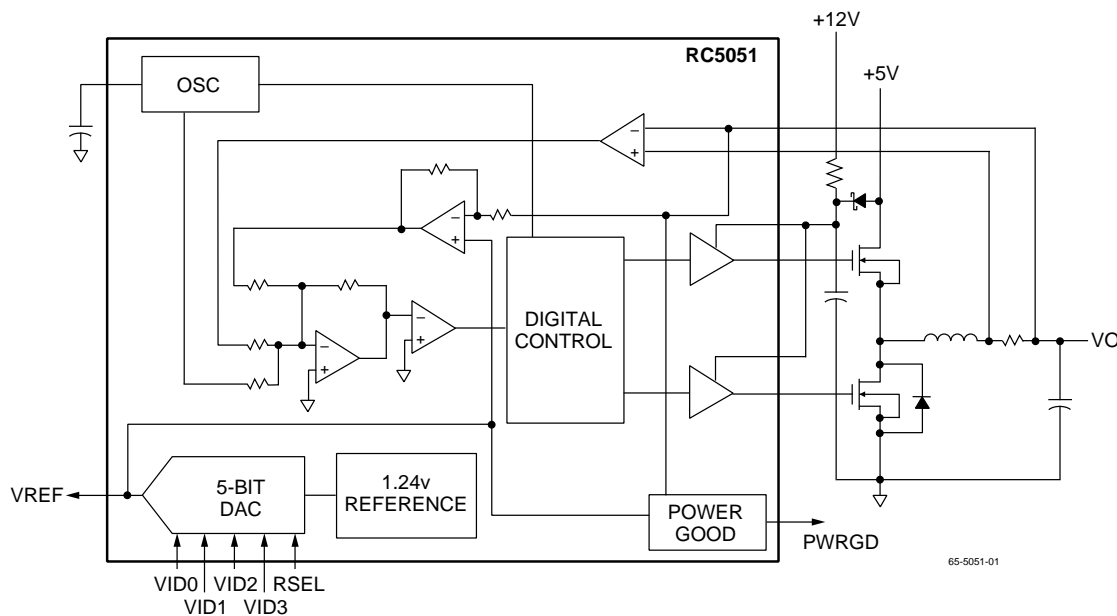

Figure 2. RC5051 Block Diagram

The HIDRV driver has a power supply, VCCQP, supplied from a 12V source as illustrated in Figure 2. The resulting voltage is sufficient to provide the gate to source voltage to the external MOSFET that is required to achieve a low $R_{DS,ON}$. Since the low side synchronous FET is referenced to ground, there is no need to boost the gate drive voltage, and its VCCP power pin can be tied to VCC.

Internal Voltage Reference

The reference included in the RC5050 and RC5051 is a precision band-gap voltage reference. The internal resistors are precisely trimmed to provide a near zero temperature coefficient (TC). Added to the reference input is the resulting output from an integrated 5-bit DAC—provided in accordance to the Pentium Pro specification guidelines. These guidelines require the DC-DC converter output to be directly programmable via a 4-bit voltage identification (VID) code. This code scales the reference voltage from 2.0V (no CPU) to 3.5V in 100mV increments. To target future generations of low-voltage processors, the RC5050 and RC5051 incorporate a VID4 pin to allow additional programmability between 1.3V and 2.05V. For guaranteed stable operation under all operating conditions, a 0.1 μ F of decoupling capacitance should be connected to the VREF pin. No load should be imposed on this pin.

Power Good (PWRGD)

The RC5050 and RC5051 Power Good function is designed in accordance with the Pentium Pro DC-DC converter specification to provide a constant voltage monitor on the VFB pin. The circuit compares the VFB signal to the VREF volt-

age and outputs an active-low interrupt signal to the CPU when the power supply voltage exceeds $\pm 12\%$ of nominal. The Power Good flag provides no other control function to the RC5050 or the RC5051.

Output Enable (OUTEN)

The DC-DC converter accepts an open collector signal for controlling the output voltage. The low state disables the output voltage. When disabled, the PWRGD output is in the low state.

Upgrade Present (UP#)

Intel specifications state that the DC-DC converter should accept an open collector signal, used to indicate the presence of an upgrade processor. The typical state is high (that is, a standard processor is in the system). When in the low or ground state (an OverDrive processor is present), the output voltage must be disabled unless the converter can supply the requirements of the OverDrive processor. When disabled, the PWRGD output must be in the low state. Because the RC5050 and RC5051 can supply the requirements of the OverDrive processor, the #UP signal is not required.

Over-Voltage Protection

The RC5050 and RC5051 constantly monitor the output voltage for protection against over voltage conditions. If the voltage at the VFB pin exceeds 20% of the selected program voltage, an over-voltage condition is assumed and the chip disables the output drive signal to the external MOSFET(s).

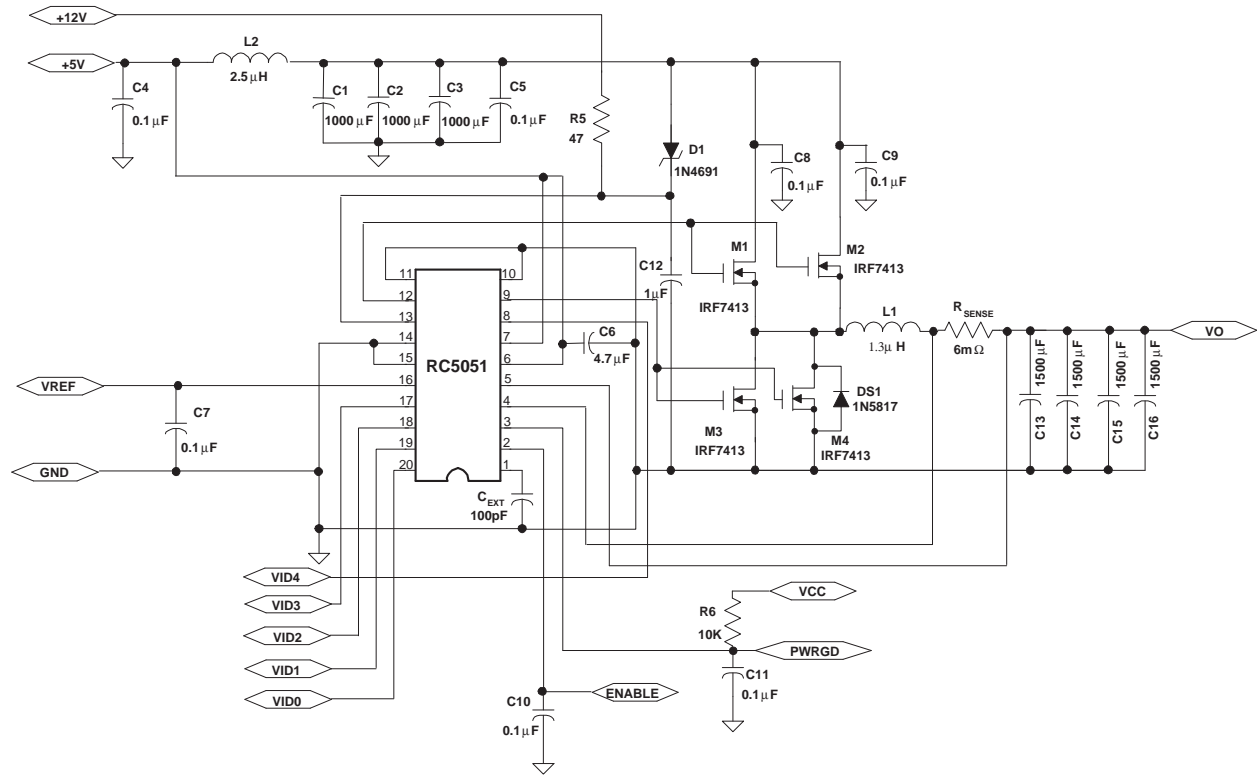

Figure 4. Synchronous DC-DC Converter Application Schematic Using the RC5051

MOSFET Selection Considerations

MOSFET Selection

This application requires N-channel Logic Level Enhancement Mode Field Effect Transistors. Desired characteristics are as follows:

- Low Static Drain-Source On-Resistance, $R_{DS,ON} < 37 \text{ m}\Omega$ (lower is better)
- Low gate drive voltage, $V_{GS} \leq 4.5\text{V}$

- Power package with low Thermal Resistance
- Drain current rating of 20A minimum
- Drain-Source voltage $> 15\text{V}$.

The on-resistance ($R_{DS,ON}$) is the primary parameter for MOSFET selection. It determines the power dissipation within the MOSFET and, therefore, significantly affects the efficiency of the DC-DC converter. Table 5 is a selection table for MOSFETs.

Table 3. MOSFET Selection Table

| Manufacturer & Model # | Conditions ¹ | | $R_{DS,ON}(\text{m}\Omega)$ | | Package | Thermal Resistance |
|---|---|---------------------------|-----------------------------|------|--------------------------------|---|
| | | | Typ. | Max. | | |
| Fuji 2SK1388 | $V_{GS} = 4\text{V}, I_D = 17.5\text{A}$ | $T_J = 25^\circ\text{C}$ | 25 | 37 | TO-220 | $\Phi_{JA} = 75$ |
| | | $T_J = 125^\circ\text{C}$ | 37 | — | | |
| Siliconix SI4410DY | $V_{GS} = 4.5\text{V}, I_D = 5\text{A}$ | $T_J = 25^\circ\text{C}$ | 16.5 | 20 | SO-8 (SMD) | $\Phi_{JA} = 50$ |
| | | $T_J = 125^\circ\text{C}$ | 28 | 34 | | |
| National Semiconductor NDP706AL NDP706AEL | $V_{GS} = 5\text{V}, I_D = 40\text{A}$ | $T_J = 25^\circ\text{C}$ | 13 | 15 | TO-220 | $\Phi_{JA} = 62.5$ $\Phi_{JC} = 1.5$ |
| | | $T_J = 125^\circ\text{C}$ | 20 | 24 | | |
| National Semiconductor NDP603AL | $V_{GS} = 4.5\text{V}, I_D = 10\text{A}$ | $T_J = 25^\circ\text{C}$ | 31 | 40 | TO-220 | $\Phi_{JA} = 62.5$ $\Phi_{JC} = 2.5$ |
| | | $T_J = 125^\circ\text{C}$ | 42 | 54 | | |
| National Semiconductor NDP606AL | $V_{GS} = 5\text{V}, I_D = 24\text{A}$ | $T_J = 25^\circ\text{C}$ | 22 | 25 | TO-220 | $\Phi_{JA} = 62.5$ $\Phi_{JC} = 1.5$ |
| | | $T_J = 125^\circ\text{C}$ | 33 | 40 | | |
| Motorola MTB75N03HDL | $V_{GS} = 5\text{V}, I_D = 37.5\text{A}$ | $T_J = 25^\circ\text{C}$ | 6 | 9 | TO-263 (D ² PAK) | $\Phi_{JA} = 62.5$ $\Phi_{JC} = 1.0$ |
| | | $T_J = 125^\circ\text{C}$ | 9.3 | 14 | | |
| Int. Rectifier IRLZ44 | $V_{GS} = 5\text{V}, I_D = 31\text{A}$ | $T_J = 25^\circ\text{C}$ | — | 28 | TO-220 | $\Phi_{JA} = 62.5$ $\Phi_{JC} = 1.0$ |
| | | $T_J = 125^\circ\text{C}$ | — | 46 | | |
| Int. Rectifier IRL3103S | $V_{GS} = 4.5\text{V}, I_D = 28\text{A}$ | $T_J = 25^\circ\text{C}$ | — | 19 | TO-220 | $\Phi_{JA} = 62.5$ $\Phi_{JC} = 1.0$ |
| | | $T_J = 125^\circ\text{C}$ | — | 31 | | |
| Intl Rectifier IRF7413 | $V_{GS} = 4.5\text{V}, I_D = 3.7\text{A}$ | $T_A = 25^\circ\text{C}$ | | 18 | SO-8 SMD | $\Phi_{JA} = 50$ |

Note:

1. $R_{DS,ON}$ values at $T_J = 125^\circ\text{C}$ for most devices were extrapolated from the typical operating curves supplied by the manufacturers and are approximations only.

Two MOSFETs in parallel.

We recommend two MOSFETs used in parallel instead of one single MOSFET. The following significant advantages are realized using two MOSFETs in parallel:

- **Significant reduction of Power dissipation.**
Maximum current of 14A with one MOSFET:

$$P_{MOSFET} = (I^2 R_{DS,ON})(Duty\ Cycle) = (14)^2(0.050^*)(3.3+0.4)/(5+0.4-0.35) = 7.2\ W$$

With two MOSFETs in parallel:

$$P_{MOSFET} = (I^2 R_{DS,ON})(Duty\ Cycle) = (14/2)^2(0.037^*)(3.3+0.4)/(5+0.4-0.35) = 1.3W/FET$$

* **Note:** $R_{DS,ON}$ increases with temperature. Assume $R_{DS,ON} = 25m\Omega$ at 25°C. $R_{DS,ON}$ can easily increase to 50mΩ at high temperature when using a single MOSFET. When using two MOSFETs in parallel, the temperature effects should not cause the $R_{DS,ON}$ to rise above the listed maximum value of 37mΩ.

- **Less heat sink required.**
With power dissipation down to around one watt and with MOSFETs mounted flat on the motherboard, considerable less heat sink is required. The junction-to-case thermal resistance for the MOSFET package (TO-220) is typically at 2°C/W and the motherboard serves as an excellent heat sink.
- **Higher current capability.**
With thermal management under control, this on-board DC-DC converter is able to deliver load currents up to 14.5A with no performance or reliability concerns.

MOSFET Gate Bias

MOSFET can be biased by one of two methods: Charge Pump and 12V Gate Bias.

- **Method 1. Charge pump (or Bootstrap) method.**
Figure 5 employs a charge pump to provide gate bias. Capacitor CP is the charge pump deployed to boost the voltage of the RC5050 output driver. When the MOSFET switches off, the source of the MOSFET is at -0.6V. VCCQP is charged through the Schottky diode to 4.5V. Thus, the capacitor CP is charged to 5V. When the MOSFET turns on, the source of the MOSFET voltage is equal to 5V. The capacitor voltage follows, and hence provides a voltage at VCCQP equal to 10V. The Schottky diode is required to provide the charge path when the MOSFET is off, and reverses bias when the VCCQP goes to 10V. The charge pump capacitor, CP, needs to be a high Q, high frequency capacitor. A 1μF ceramic capacitor capacitor is recommended here.

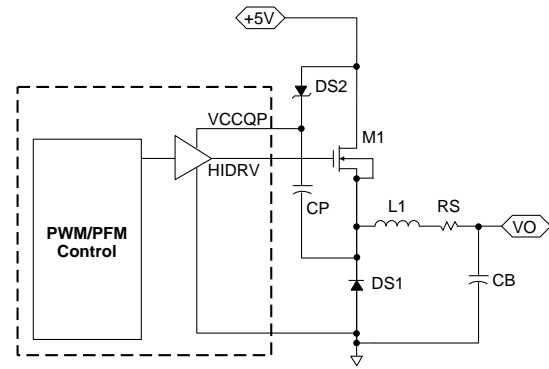

Figure 5. Charge Pump Configuration

- **Method 2. 12V Gate Bias.**
Figure 6 illustrates how a 12V source can be used to bias the VCCQP. A 47Ω resistor is used to limit the transient current into the VCCQP pin and a 1μF capacitor filter is used to filter the VCCQP supply. This method provides a higher gate bias voltage (V_{GS}) to the MOSFET, and therefore reduces the $R_{DS,ON}$ of the MOSFET and reduces the power loss due to the MOSFET. Figure 7 shows how $R_{DS,ON}$ reduces dramatically with V_{GS} increases. A 6.2V Zener diode (D1) is placed to clamp the voltage at VCCQP to a maximum of 12V and ensure that the absolute maximum voltage of the IC will not be exceeded

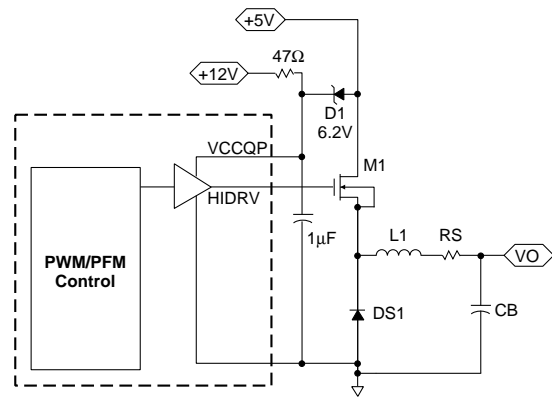

Figure 6. 12V Gate Bias Configuration

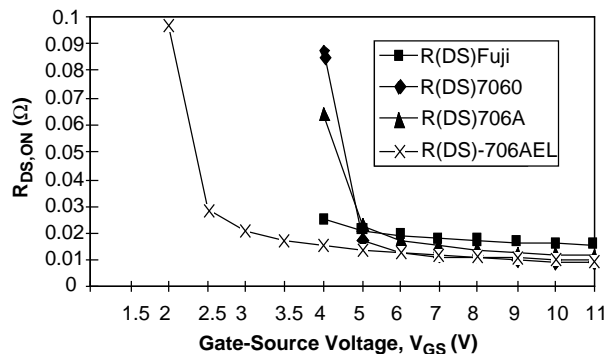

Figure 7. $R_{DS,ON}$ vs. V_{GS} for Selected MOSFETs

Converter Efficiency

Losses due to parasitic resistance in the switches, coil, and sense resistor dominate at high load-current level. The major loss mechanisms under heavy loads, in usual order of importance, are:

- MOSFET I²R Losses
- Coil Losses
- Sense Resistor Losses

- gate-charge losses
- diode-conduction losses
- transition losses
- Input Capacitor losses
- losses due to the operating supply current of the IC.

Calculation of Converter Efficiency Under Heavy Loads

$$\text{Efficiency} = \frac{P_{\text{OUT}}}{P_{\text{IN}}} = \frac{I_{\text{OUT}} \times V_{\text{OUT}}}{I_{\text{OUT}} \times V_{\text{OUT}} + P_{\text{LOSS}}}$$

$$P_{\text{LOSS}} = PD_{\text{MOSFET}} + PD_{\text{COIL}} + PD_{\text{SENDER}} + PD_{\text{GATE}} + PD_{\text{DIODE}} + PD_{\text{TRAN}} + PD_{\text{CAP}} + PD_{\text{IC}}$$

$$\text{where } PD_{\text{MOSFET}} = I_{\text{OUT}}^2 \times R_{\text{DS,ON}} \times \text{DutyCycle}, \text{ where } \text{DutyCycle} = \frac{V_{\text{OUT}} + V_{\text{D}}}{V_{\text{IN}} + V_{\text{D}} - V_{\text{SW}}}$$

$$PD_{\text{COIL}} = I_{\text{OUT}}^2 \times R_{\text{COIL}}$$

$$PD_{\text{SENDER}} = I_{\text{OUT}}^2 \times R_{\text{SENSE}}$$

$$PD_{\text{GATE}} = q_{\text{GATE}} \times f \times 5V, \text{ where } q_{\text{GATE}} \text{ is the gate charge and } f \text{ is the switching frequency}$$

$$PD_{\text{DIODE}} = V_f \times I_D (1 - \text{DutyCycle})$$

$$PD_{\text{TRAN}} = \frac{V_{\text{IN}}^2 \times C_{\text{RSS}} \times I_{\text{LOAD}} \times f}{I_{\text{DRIVE}}}, \text{ where } C_{\text{RSS}} \text{ is the reverse transfer capacitance of the high-side MOSFET.}$$

$$PD_{\text{CAP}} = I_{\text{RMS}}^2 \times \text{ESR}$$

$$PD_{\text{IC}} = V_{\text{CC}} \times I_{\text{CC}}$$

Example

$$\text{DutyCycle} = \frac{3.3 + 0.5}{5 + 0.5 - 0.3} = 0.73$$

$$PD_{\text{MOSFET}} = 10^2 \times 0.030 \times 0.73 = 2.19W$$

$$PD_{\text{COIL}} = 10^2 \times 0.010 = 1W$$

$$PD_{\text{SENDER}} = 10^2 \times 0.0065 = 0.65W$$

$$PD_{\text{GATE}} = CV \times f \times 5V = 1.75\text{nf} \times (9 - 1)V \times 285\text{Khz} \times 5V = 0.019W$$

$$PD_{\text{DIODE}} = 0.5 \times 10(1 - 0.73) = 1.35W$$

$$PD_{\text{TRAN}} = \frac{5^2 \times 400\text{pf} \times 10 \times 285\text{khz}}{0.7A} \approx 0.010W$$

$$PD_{\text{CAP}} = (7.5 - 2.5)^2 \times 0.015 = 0.37W$$

$$PD_{\text{IC}} = 0.2W$$

$$PD_{\text{LOSS}} = 2.19W + 1.0W + 0.65W + 0.019W + 1.35W + 0.010W + 0.37W + 0.2W = 5.789W$$

$$\therefore \text{Efficiency} = \frac{3.3 \times 10}{3.3 \times 10 + 5.815} \approx 85\%$$

Selecting the Inductor

The inductor is one of the most critical components to be selected for a DC-DC converter application. The critical parameters are inductance (L), maximum DC current (I_O), and DC coil resistance (R_l). The inductor core material is a crucial factor in determining the amount of current the inductor is able to withstand. As with all engineering designs, tradeoffs exist between various types of core materials. In general, Ferrites are popular due to low cost, low EMI properties, and high frequency (>500KHz) characteristics. Molypermalloy powder (MPP) materials exhibit good saturation characteristics, low EMI, and low hysteresis losses, but tend to be expensive and more effectively utilized at operating frequencies below 400KHz. Another critical parameter is the DC winding resistance of the inductor. This value should typically be reduced as much as possible, as the power loss in the DC resistance degrades the efficiency of the converter by the relationship: $P_{loss} = I_O^2 \times R_l$. The value of the inductor is a function of the oscillator duty cycle (T_{ON}) and the maximum inductor current (I_{PK}). I_{PK} can be calculated from the relationship:

$$I_{PK} = I_{MIN} + \left(\frac{V_{IN} - V_{SW} - V_D}{L} \right) T_{ON}$$

Where T_{ON} is the maximum duty cycle and V_D is the forward voltage of diode DS1.

Then the inductor value can be calculated using the relationship:

$$L = \left(\frac{V_{IN} - V_{SW} - V_D}{I_{PK} - I_{MIN}} \right) T_{ON}$$

Where V_{SW} ($R_{DS,ON} \times I_O$) is the drain-to-source voltage of M1 when it is switched on.

Implementing Short Circuit Protection

Intel currently requires all power supply manufacturers to provide continuous protection against short circuit conditions that may damage the CPU. To address this requirement, Raytheon Electronics has implemented a current sense methodology to limit the power delivered to the load in the event of overcurrent. The voltage drop created by the output current across a sense resistor is presented to one terminal of an internal comparator with hysteresis. The other comparator terminal has the threshold voltage, nominally of 120mV. Table 6 states the limits for the comparator threshold of the Switching Regulator.

Table 6. RC5050 Short Circuit Comparator Threshold Voltage

| | Short Circuit Comparator $V_{threshold}$ (mV) |
|---------|--|
| Typical | 120 |
| Minimum | 100 |
| Maximum | 140 |

When designing the external current sense circuitry, pay careful attention to the output limitations during normal operation and during a fault condition. If the short circuit protection threshold current is set too low, the DC-DC converter may not be able to continuously deliver the maximum CPU load current. If the threshold level is too high, the output driver may not be disabled at a safe limit and the resulting power dissipation within the MOSFET(s) may rise to destructive levels.

The following is the design equation used to set the short circuit threshold limit:

$$R_{SENSE} = \frac{V_{th}}{I_{SC}}, \text{ where: } I_{SC} = \text{Output short circuit current}$$

$$I_{SC} \geq I_{inductor} = I_{Load, max} + \frac{(I_{pk} - I_{min})}{2}$$

Where I_{pk} and I_{min} are peak ripple current and $I_{load, max}$ = maximum output load current.

You must also take into account the current ($I_{pk} - I_{min}$), or the ripple current flowing through the inductor under normal operation. Figure 8 illustrates the inductor current waveform for the RC5050 DC-DC converter at maximum load.

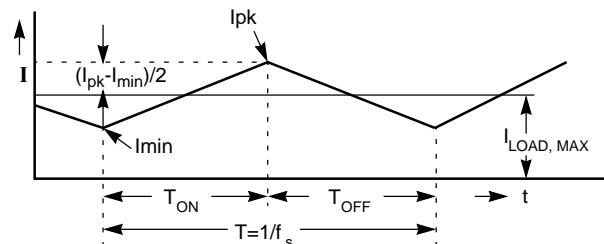

Figure 8. Typical DC-DC Converter Inductor Current Waveform

The calculation of this ripple current is as follows:

$$\frac{(I_{pk} - I_{min})}{2} = \frac{(V_{IN} - V_{SW} - V_{OUT})}{L} \times \frac{(V_{OUT} + V_D)}{(V_{IN} - V_{SW} + V_D)} T$$

where:

V_{IN} = input voltage to converter,

V_{SW} = voltage across switcher MOSFET = $I_{LOAD} \times R_{DS,ON}$,

V_D = Forward Voltage of the Schottky diode,

T = the switching period of the converter = $1/f_s$, and

f_s = switching frequency.

For an input voltage of 5V, output voltage of 3.3V, L equals 1.3 μ H and a switching frequency of 285KHz (using $C_{EXT} = 100$ pF), the inductor current can be calculated at approximately 1A:

$$\frac{(I_{pk} - I_{min})}{2} = \frac{(5.0 - 14.5 \times 0.037 - 3.3)}{1.3 \times 10^{-6}} \times \frac{(3.3 + 0.5)}{5.0 - 14.5 \times 0.037 + 0.5} \times \frac{1}{285 \times 10^3} = 2A$$

Therefore, for load current of 14.5A, the peak current through the inductor, I_{pk} , is found to be approximately 15.5A:

$$I_{SC} \geq I_{inductor} = I_{Load, max} + \frac{(I_{PK} - I_{min})}{2} = 14.5 + 2 = 16.5A$$

Therefore, the short circuit detection threshold must be at least 16.5A.

The next step is to determine the value of the sense resistor. Including sense resistor tolerance, the sense resistor value can be approximated as follows

$$R_{SENSE} = \frac{V_{th, min}}{I_{SC}} \times (1 - TF) = \frac{V_{th, min}}{1.0 + I_{Load, max}} \times (1 - TF)$$

Where TF = Tolerance Factor for the sense resistor.

Table 7 describes tolerance, size, power capability, temperature coefficient and cost of various type of sense resistors.

Table 7. Comparison of Sense Resistors

| Description | Motherboard Trace Resistor | Discrete Iron Alloy Resistor (IRC) | Discrete Metal Strip Surface Mount Resistor (Dale) | Discrete MnCu Alloy Wire Resistor | Discrete CuNi Alloy Wire Resistor (Copel) |
|-------------------------|---------------------------------------|------------------------------------|--|-----------------------------------|---|
| Tolerance Factor (TF) | ±29% | ±5% (±1% available) | ±1% | ±10% | ±10% |
| Size (L x W x H) | 2" x 0.2" x 0.001" (1 oz Cu trace) | 0.45" x 0.065" x 0.200" | 0.25" x 0.125" x 0.025" | 0.200" x 0.04" x 0.160" | 0.200" x 0.04" x 0.100" |
| Power capability | >50A/in | 1 watt (3W and 5W available) | 1 watt | 1 watt | 1 watt |
| Temperature Coefficient | +4,000 ppm | +30 ppm | ±75 ppm | ±30 ppm | ±20 ppm |
| Cost @10,000 piece | Low included in motherboard | \$0.31 | \$0.47 | \$0.09 | \$0.09 |

Refer to Appendix A for Directory of component suppliers

Based on the Tolerance Factor in the above table, for an embedded PC trace resistor and for $I_{load, max} = 14.5A$:

$$R_{SENSE} = \frac{V_{th, min}}{2.0A + I_{Load, max}} \times (1 - TF) =$$

$$\frac{100mV}{2.0A + 14.5A} \times (1 - 29\%) = 4.3m\Omega$$

For a discrete resistor and for $I_{load, max} = 14.5A$:

$$R_{SENSE} = \frac{V_{th, min}}{2.0A + I_{Load, max}} \times (1 - TF) =$$

$$\frac{100mV}{2.0A + 14.5A} \times (1 - 5\%) = 5.8m\Omega$$

For user convenience, Table 8 lists the recommended values for sense resistors for various load currents using embedded PC trace resistors and discrete resistors.

Table 8. R_{sense} for Various Load Currents

| $I_{Load, max}$ (A) | R_{SENSE} PC Trace Resistor (mΩ) | R_{SENSE} Discrete Resistor (mΩ) |
|---------------------|------------------------------------|------------------------------------|
| 10.0 | 5.9 | 7.9 |
| 11.2 | 5.4 | 7.2 |
| 12.4 | 4.9 | 6.6 |
| 13.9 | 4.5 | 6.0 |
| 14.0 | 4.4 | 5.9 |
| 14.5 | 4.3 | 5.8 |

Discrete Sense Resistor

Discrete Iron Alloy resistors come in variety of tolerances and power ratings, and are most ideal for precision implementation. MnCu Alloy wire resistors or CuNi Alloy wire resistors are ideal for low cost implementations.

Embedded Sense Resistor (PC Trace Resistor)

Embedded PC trace resistors have the advantage of near zero cost implementation. However, the value of the PC trace resistor has large variations. Embedded resistors have 3 major error sources: the sheet resistivity of the inner layer, the mismatch due to L/W, and the temperature variation of the resistor. All three error sources must be considered for laying out embedded sense resistors.

• **Sheet resistivity.**

For 1 ounce copper, the thickness variation is typically 1.15 mil to 1.35 mil. Therefore error due to sheet resistivity is $(1.35 - 1.15)/1.25 = 16\%$

• **Mismatch due to L/W.**

Percent error in L/W is dictated by geometry and the power dissipation capability of the sense resistor. The sense resistor must be able to handle the load current and therefore requires a minimum width which is calculated as follows.

$$W = \frac{I_L}{0.05}$$

where: W = minimum width required for proper power dissipation (mils) and I_L = Load Current in Amps.

For 15A of load current, minimum width required is 300mils, which reflects a 1% L/W error.

• **Thermal Consideration.**

Due to I^2R power losses the surface temperature of the resistor will increase leading to a higher value. In addition, ambient temperature variation will add the change in resistor value:

$$R = R_{20}[1 + \alpha_{20}(T - 20)]$$

where: R_{20} is the resistance at 20°C, $\alpha_{20} = 0.00393/^\circ\text{C}$, T is the operating temperature, and R is the desired value.

For temperature $T = 50^\circ\text{C}$, the %R change = 12%.

Table 9 is the summary of the tolerance for the Embedded PC Trace Resistor.

Table 9. Summary PC Trace Resistor Tolerance

| | |
|--|-----|
| Tolerance due to Sheet Resistivity variation | 16% |
| Tolerance due to L/W error | 1% |
| Tolerance due to temperature variation | 12% |
| Total Tolerance for PC Trace Resistor | 29% |

Design Rules for Using an Embedded Resistor

The basic equation for laying an embedded resistor is:

$$R = \rho \times \frac{L}{W \times t}$$

where:

- ρ = Resistivity($\mu\Omega\text{-mil}$),
- L = Length(mils),
- W = Width(mils), and
- t = Thickness(mils).

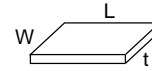

For 1oz copper, $t = 1.35$ mils, $\rho = 717.86 \mu\Omega\text{-mil}$, $L/W = 1$ Square (\square).

For example, you can layout a 5.30mΩ embedded sense resistor using the equations above:

$$W = \frac{I_L}{0.05} = \frac{10}{0.05} = 200\text{mils}$$

$$L = \frac{R \times W \times t}{\rho} = \frac{0.00530 \times 200 \times 1.35}{717.86} = 2000\text{mils}$$

$$L/W = 10 \square$$

Therefore, to model 5.30mΩ embedded sense resistor, you need $W = 200$ mils and $L = 2000$ mils. Refer to Figure 9.

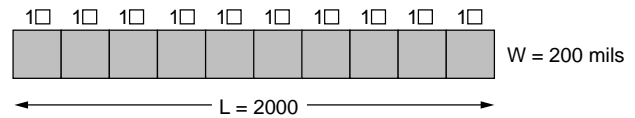

Figure 9. 5.30mΩ Sense Resistor (10 \square)

You can also implement the sense resistor in the following manner. Each corner square is counted as 0.6 square since current flowing through the corner square does not flow uniformly and it is concentrated towards the inside edge, as shown in Figure 10.

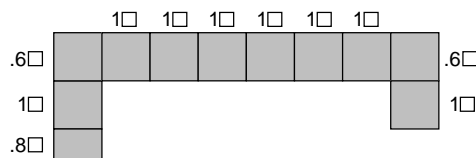

Figure 10. 5.30mΩ Sense Resistor (10 \square)

A Design Example Combining an Embedded Resistor and a Discrete Resistor

For low cost implementation, the embedded PC trace resistor is most desirable. However, its wide tolerance (29%) presents a challenge. In addition, requirements for the CPU change frequently, and, thus, the maximum load current may be subject to change. Combining embedded resistors with discrete resistors may be a desirable option. Figure 11 shows a design that provides flexibility with a solution to address wide tolerances.

In this design, you have the option to choose an embedded or a discrete MnCu sense resistor. To use the discrete sense resistor, populate R21 with a shorting bar (zero Ohm resistor) for proper Kelvin connection and add the MnCu sense resistor. To use the embedded sense resistor, on the other hand, populate R22 with a shorting bar for Kelvin connection.

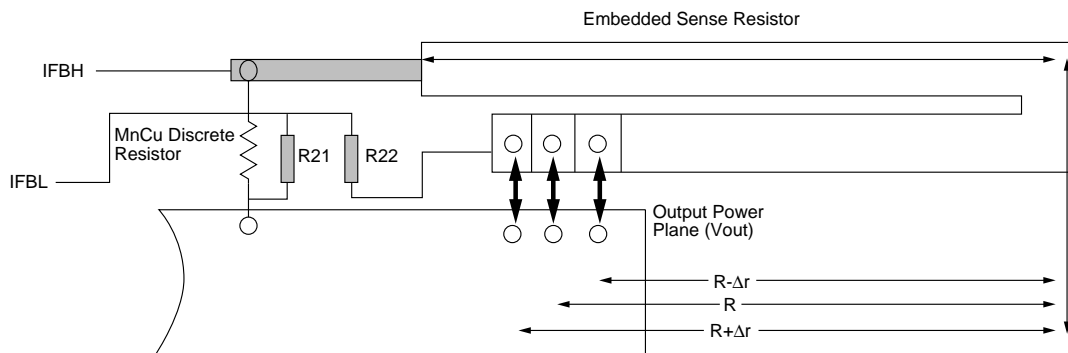

Figure 11. Short Circuit Sense Resistor Design Using a PC Trace Resistor and an Optional Discrete Sense Resistor

tion. The embedded sense resistor allows the user to choose a plus or a minus delta resistance tap to offset any large sheet resistivity change. In this design, the center tap yields 6mΩ, the left tap yields 6.7mΩ, and the right tap yields 5.3mΩ.

RC5050 and RC5051 Short Circuit Current Characteristics

The RC5050 and RC5051 short circuit current characteristic includes a hysteresis function that prevents the DC-DC converter from oscillating in the event of a short circuit. Figure 12 shows the typical characteristic of the DC-DC converter circuit with a 6mΩ sense resistor. The converter exhibits a normal load regulation characteristic until the voltage across the resistor exceeds the internal short circuit threshold of 120mV. At this point, the internal comparator trips and signals the controller to turn off the gate drive to the power MOSFET. This causes a drastic reduction in output voltage as the load regulation collapses into the short circuit control mode. The output voltage does not return to its nominal value the output current is reduced to a value within the safe range for the DC-DC converter.

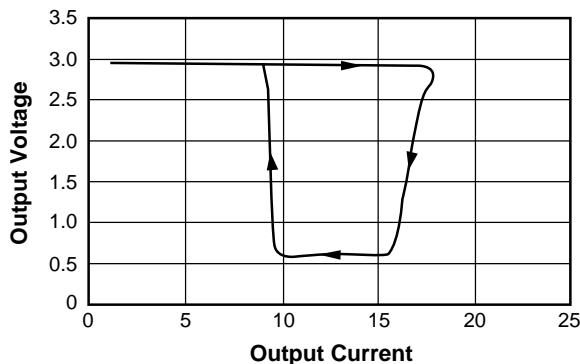

Figure 12. RC5050 Short Circuit Characteristic

Power Dissipation Consideration During a Short Circuit Condition

The RC5050 and RC5051 controllers respond to an output short circuit by drastically changing the duty cycle of the gate drive signal to the power MOSFET. In doing this, the power MOSFET is protected from stress and from eventual failure. Figure 13A shows the gate drive signal of a typical RC5050 operating in continuous mode with a load current of 10A. The duty cycle is set by the ratio of the input voltage to the output voltage. If the input voltage is 5V, and the output voltage is 3.1V, the ratio of Vout/ Vin is 62%. Figure 13B shows the result of a RC5050 going into its short circuit mode with a duty cycle approximately of 20%. Calculating the power in the MOSFET at each condition on the graph (Figure 12) shows how the protection works. The power dissipated in the MOSFET at normal operation for a load current of 14.5A, is given by:

$$P_D = I^2 \times R_{ON} \times \text{DutyCycle} = \left(\frac{14.5}{2}\right)^2 \times .037 \times .62 = 1.2W$$

for each MOSFET.

The power dissipated in the MOSFET at short circuit condition for a peak short current of 20A, is given by:

$$P_D = \left(\frac{20}{2}\right)^2 \times .037 \times .2 = 0.74W$$

for each MOSFET.

These calculations show that the MOSFET is not being over-stressed during a short circuit condition.

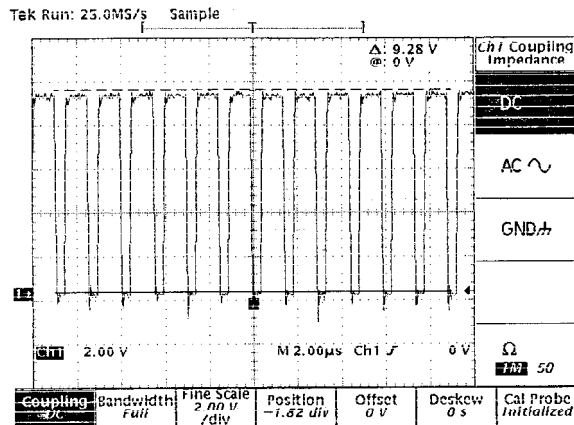

Figure 13A. V_{CCQP} Output Waveform for Normal Operation Condition with $V_{out} = 3.3V@10A$

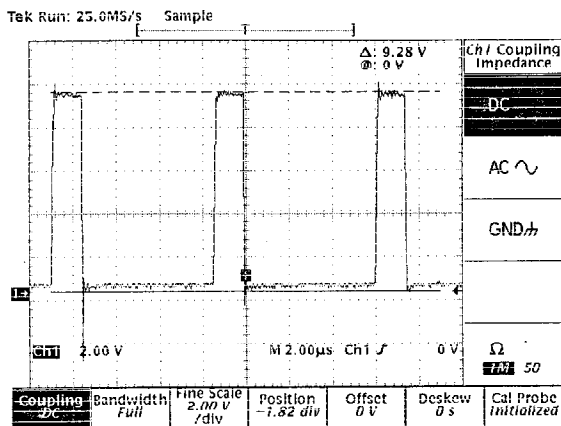

Figure 13B. V_{CCQP} Output Waveform for Output Shorted to Ground

Power dissipation on the Schottky diode during a short circuit condition must also be considered. During normal operation, the Schottky diode dissipates power while the power MOSFET is off. The power dissipated in the diode during normal operation, is given by:

$$P_{D, Diode} = I_F \times V_F \times (1 - \text{DutyCycle}) =$$

$$14.5 \times 0.5V \times (1 - 0.62) = 2.75W$$

During a short circuit, the duty cycle dramatically reduces to around 20%. The forward current in the short circuit condition decays exponentially through the inductor. The power dissipated in the diode during short circuit condition, is approximately given by:

$$I_{F, ending} = I_{sc} \times e^{-\frac{1}{L/R}} = 20A \times e^{-\frac{1.5\mu s}{1.3\mu s}} \approx 7.9A$$

$$I_{F, ave} \approx (20A + 7.9A)/2 \approx 14A$$

$$P_{D, Diode} = I_{F, ave} \times V_F \times (1 - \text{DutyCycle}) =$$

$$14 \times 0.45 \times 0.8 \approx 5W$$

Thus, for the Schottky diode, the thermal dissipation during a short circuit is greatly magnified. This requires that the thermal dissipation of the diode be properly managed by an appropriate heat sink. To protect the Schottky from being destroyed in the event of a short circuit, you should limit the junction temperature to less than 130°C. You can find the required thermal resistance using the equation for maximum junction temperature:

$$P_D = \frac{T_{J(max)} - T_A}{R_{\theta JA}}$$

Assuming that the ambient temperature is 50°C,

$$R_{\theta JA} = \frac{T_{J(max)} - T_A}{P_D} = \frac{130 - 50}{5} = 16^\circ C/W$$

Thus, you need to provide a heat sink that gives the Schottky diode a thermal resistance of 16°C/W or lower to protect the device during an indefinite short.

In summary, with proper heat sink, the Schottky diode is not over-stressed during a short circuit condition.

Schottky Diode Selection

The application circuit diagram of Figure 3 shows a Schottky diode, DS1. In non-synchronous mode, DS1 is used as a fly-back diode to provide a constant current path for the inductor when M1 is turned off. Table 10 shows the characteristics of several Schottky diodes. Note that MBR2015CTL has a very low forward voltage drop. This diode is ideal for applications where the output voltage is required to be less than 2.8V.

Table 10. Schottky Diode Selection Table

| Manufacturer Model # | Conditions | Forward Voltage V_F |
|----------------------|---|-----------------------|
| Philips PBYR1035 | $I_F = 20A; T_j = 25^\circ C$ $I_F = 20A; T_j = 125^\circ C$ | < 0.84v < 0.72v |
| Motorola MBR2035CT | $I_F = 20A; T_j = 25^\circ C$ $I_F = 20A; T_j = 125^\circ C$ | < 0.84v < 0.72v |
| Motorola MBR1545CT | $I_F = 15A; T_j = 25^\circ C$ $I_F = 15A; T_j = 125^\circ C$ | < 0.84v < 0.72v |
| Motorola MBR2015CTL | $I_F = 20A; T_j = 25^\circ C$ $I_F = 20A; T_j = 150^\circ C$ | < 0.58v < 0.48v |

Output Filter Capacitors

Output ripple performance and transient response are functions of the filter capacitors. Since the 5V supply of a PC motherboard may be located several inches away from the DC-DC converter, the input capacitance may play an important role in the load transient response of the RC5050 and RC5051. The higher input capacitance, the more charge storage is available for improving current transfer through the

FET. Low Equivalent Series Resistance (ESR) capacitors are best suited for this type of application. Incorrect selection can hinder the converter's overall performance. The input capacitor should be placed as close to the drain of the FET as possible to reduce the effect of ringing caused by long trace lengths.

The ESR rating of a capacitor is a difficult number to quantify. ESR is defined as the resonant impedance of the capacitor. Since the capacitor is actually a complex impedance device having resistance, inductance, and capacitance, it is natural for this device to have a resonant frequency. As a rule, the lower the ESR, the better suited the capacitor is for use in switching power supply applications. Many capacitor manufacturers do not supply ESR data. A useful estimate of the ESR can be obtained using the following equation:

$$ESR = \frac{DF}{2\pi fC}$$

where DF is the dissipation factor of the capacitor, f is the operating frequency, and C is the capacitance in farads.

With this in mind, correct calculation of the output capacitance is crucial to the performance of the DC-DC converter. The output capacitor determines the overall loop stability, output voltage ripple, and load transient response. The calculation is as follows:

$$C(\mu F) = \frac{I_O \times \Delta T}{\Delta V - I_O \times ESR}$$

where ΔV is the maximum voltage deviation due to load transients, ΔT is the reaction time of the power source (loop response time for the RC5050 and RC5051 is approximately 2 μ s), and I_O is the output load current.

For $I_O = 12.2A$ (0-13A load step) and $\Delta V = 100mV$, the bulk capacitance required can be approximated as follows:

$$C(\mu F) = \frac{I_O \times \Delta T}{\Delta V - I_O \times ESR} = \frac{12.2A \times 2\mu s}{100mV - 12.2A \times 7.5m\Omega} = 2870\mu F$$

Because the control loop response of the controller is not instantaneous, the initial load transient must be supplied entirely by the output capacitors. The initial voltage deviation is determined by the total ESR of the capacitors used and the parasitic resistance of the output traces. For a detailed analysis of capacitor requirements in a high-end microprocessor system, please refer to Application Bulletin 5.

Input Filter

The DC-DC converter should include an input inductor between the system +5V supply and the converter input as described below. This inductor serves to isolate the +5V supply from the noise in the switching portion of the DC-DC converter, and to limit the inrush current into the input capacitors during power up. A value of 2.5 μ H is recommended, as illustrated in Figure 14.

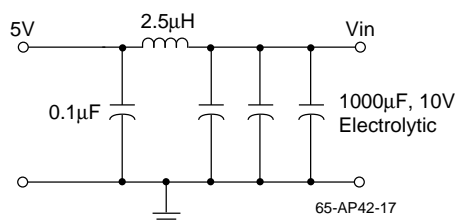

Figure 14. Input Filter

Bill of Material

Table 11 is the Bill of Material for the Application Circuits of Figure 3 and Figure 4.

Table 11. Bill of Materials for a 13A Pentium Pro Klamath Application

| Quantity | Reference | Manufacturer Part Order # | Description | Requirements and Comments |
|----------|------------------------------|------------------------------|--|-----------------------------------|
| 7 | C4, C5, C7, C8, C9, C10, C11 | Panasonic ECU-V1H104ZFX | 0.1 μ F 50V capacitor | |
| 1 | C6 | Panasonic ECSH1CY475R | 4.7 μ F 16V capacitor | |
| 1 | Cext | Panasonic ECU-V1H121JCG | 120pF capacitor | |
| 1 | C12 | Panasonic ECSH1CY105R | 1 μ F 16V capacitor | |
| 3 | C1, C2, C3 | United Chemi-con LXF16VB102M | 1000 μ F 6.3V electrolytic capacitor 10mm x 20mm | ESR < 0.047 Ω |
| 4 | C13, C14, C15, C16 | Sanyo 6MV1500GX | 1500 μ F 6.3V electrolytic capacitor 10mm x 20mm | ESR < 0.047 Ω |
| 1 | DS1 (note 1) | Motorola MBR2015CT | Shottky diode, 15A | Vf < 0.52V @ I _f = 10A |
| 1 | D1 | Motorola 1N4691 | 6.2V Zener Diode | |

Table 11. Bill of Materials for a 13A Pentium Pro Klamath Application (continued)

| Quantity | Reference | Manufacturer Part Order # | Description | Requirements and Comments |
|-----------------|-----------|------------------------------------|---|--|
| 1 | L1 | Pulse Engineering PE-53680 | 1.3μH inductor | |
| 1 | L2* | Pulse Engineering PE-53681 | 2.5μH inductor | *Optional—helps reduce ripple on 5v line |
| 2-4 (note 2) | M1-M4 | International Rectifier IRF7413 | N-Channel Logic Level Enhancement Mode MOSFET | $R_{DS,ON} < 18m\Omega$ $V_{GS} = 4.5V, I_D = 5A$ |
| 1 | Rsense | Coppel CuNi Wire resistor | 6 mΩ, 1W | |
| 1 | R5 | Panasonic ERJ-6GEY050Y | 47Ω 5% resistors | |
| 1 | R6 | Panasonic ERJ-6ENF10.0KY | 10KΩ 5% resistor | |
| | U1 | Raytheon RC5050M or RC5051M | Programmable DC-DC converter | |

Refer to Appendix A for Directory of component suppliers.

Notes:

1. When used in synchronous mode, a 1A schottky diode such as the 1N5817 should be substituted for the MBR2015CT.
2. A target $R_{DS,ON}$ value of 10mΩ should be used for each output driver switch. Refer to Table 3 for alternative MOSFETs.

PCB Layout Guidelines and Considerations

PCB Layout Guidelines

- Placement of the MOSFETs relative to the RC5050 is critical. Place the MOSFETs (M1 & M2) so that the trace length of the HIDRV pin from the RC5050 to the FET gates is minimized. A long lead length on this pin would cause high amounts of ringing due to the inductance of the

trace and the large gate capacitance of the FET. This noise radiates all throughout the board, and, because it is switching at such a high voltage and frequency, it is very difficult to suppress.

Figure 15 shows an example of good placement for the MOSFETs in relation to the RC5050. In addition, this figure shows an example of problematic placement for the MOSFETs.

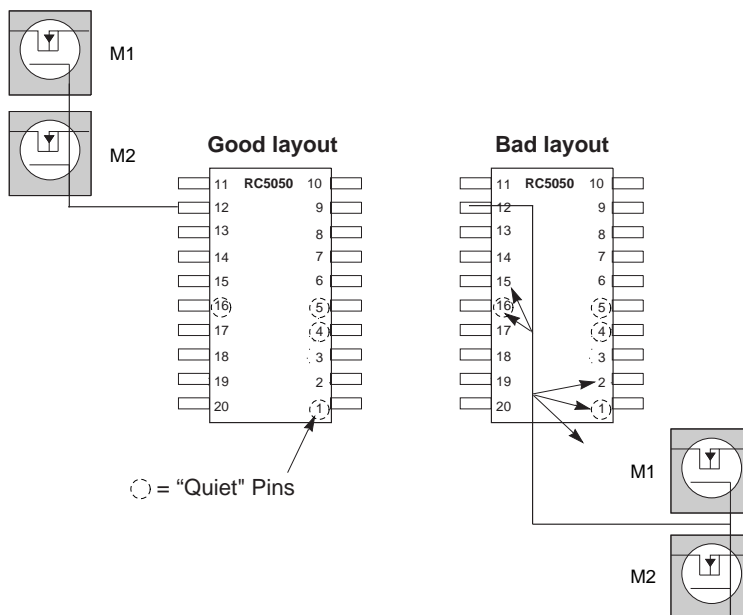

Figure 15. Placement of the MOSFETs

In general, all of the noisy switching lines should be kept away from the quiet analog section of the RC5050. That is, traces that connect to pins 12 and 13 (HIDRV and VCCQP) should be kept far away from the traces that connect to pins 1 through 5, and pin 16.

- Place the 0.1µF decoupling capacitors as close to the RC5050 pins as possible. Extra lead length negates their ability to suppress noise.
- Each VCC and GND pin should have its own via to the appropriate plane. This helps to provide isolation between pins.
- Surround the CEXT timing capacitor with a ground trace. Be sure to place a ground or power plane under the capacitor for further noise isolation to provide additional shielding to the oscillator pin 1 from the noise on the PCB. In addition, place this capacitor as close to the RC5050 pin 1 as possible.
- Place the MOSFETs, inductor and Schottky as close together as possible for the same reasons on the first bullet above. Place the input bulk capacitors as close to the drains of MOSFETs as possible. In addition, placement of a 0.1µF decoupling capacitor right on the drain of each MOSFET helps to suppress some of the high frequency switching noise on the input of the DC-DC converter.

- Place the output bulk capacitors as close to the CPU as possible to optimize their ability to supply instantaneous current to the load in the event of a current transient. Additional space between the output capacitors and the CPU allows the parasitic resistance of the board traces to degrade the DC-DC converter’s performance under severe load transient conditions, causing higher voltage deviation. For more detailed information regarding capacitor placement, refer to Application Bulletin AB-5.
- The traces that run from the RC5050 IFB (pin 4) and VFB (pin 5) pins should be run next to each other and Kelvin connected to the sense resistor. Running these lines together prevents some of the common mode noise that is presented to the RC5050 feedback input. Try, as much as possible, to run the noisy switching signals (HIDRV & VCCQP) on one layer, but use the inner layers for power and ground only. If the top layer is being used to route all of the noisy switching signals, use the bottom layer to route the analog sensing signals VFB and IFB.

Example of a PC Motherboard Layout and Gerber File.

This section shows a reference design for motherboard implementation of the RC5050 along with the Layout Gerber File and Silk Screen. The actual PCAD Gerber File can be obtained from Raytheon Electronics local Sales Office or from the Semiconductor Division Marketing department at 415-966-7819.

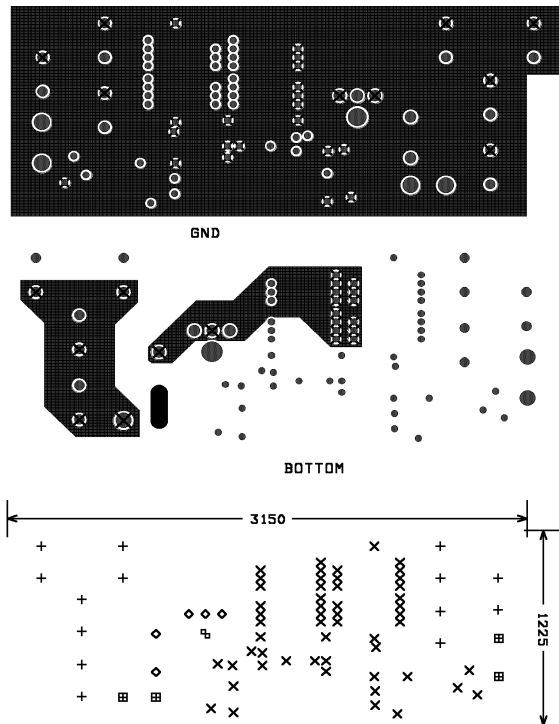
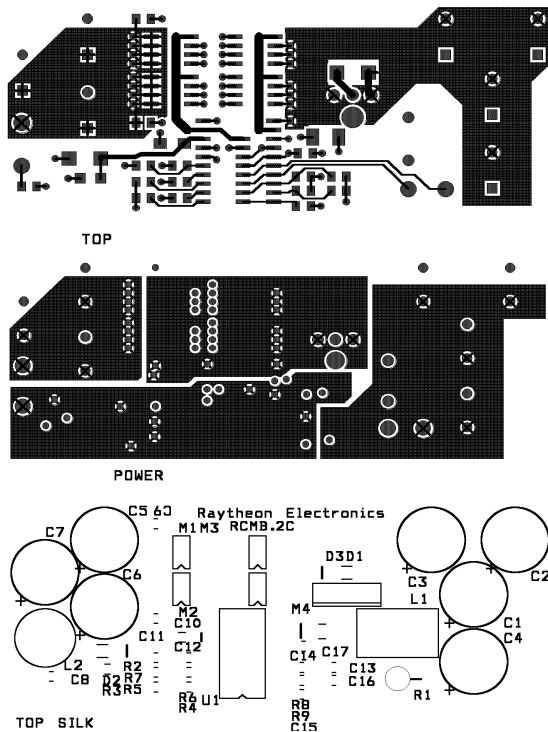

Guidelines for Debugging and Performance Evaluations

Debugging Your First Design Implementation

1. Note the setting of the VID pins to know what voltage is to be expected.
2. Do not connect any load to the circuit. While monitoring the output voltage, apply power to the part with current limiting at the power supply. This ensures that no catastrophic shorts are present.
3. If proper voltage is not achieved go to "Procedures" below.
4. When you have proper voltage, increase the current limiting of the power supply to 16A.
5. Apply load at 1A increments. An active load (HP6060B or equivalent) is suggested.
6. In case of poor regulation refer to "Procedures" below.

Procedures

1. If there is no voltage at the output and the circuit is not drawing current look for openings in the connections, check the circuitry versus schematic, and check the power supply pins at the device to make sure that voltage(s) are applied.
2. If there is no voltage at the output and the circuit is drawing excessive current (>100mA) with no load, check for possible shorts. Determine the path of the excessive current and which device is drawing it—this current may be drawn by peripheral components.
3. If the output voltage comes close to the expected value, check the VID inputs at the device pins. The part is factory set to correspond to the VID inputs.
4. Premature shut down can be caused by an inappropriate value of the sense resistor. See the "Sense Resistor" section.
5. Poor load regulation can be due to many causes. Check the voltages and signals at the critical pins.
6. The VREF pin should be at the voltage set by the VID pins. If the power supply pins and the VID pins are correct the VREF should have the correct voltage.
7. Next check the oscillator pin. You should see a saw tooth wave at the frequency set by the external capacitor.
8. When the VREF and CEXT pins are checked and correct and the output voltage is incorrect, look at the waveform at VCCQP. This pin should be swinging from ground to +12V (in the +12V application), and from slightly below +5V to about +10V (charge pump application). If the VCCQP pin is noisy, with ripples/overshoots riding on it this may make the converter not to function correctly.
9. Next, look at HIDRV pin. This pin directly drives the gate of the FET. It should provide a gate drive (V_{gs}) of about 5V when turning the FET on. A careful study of the layout is recommended. Refer to the "PCB Layout Guidelines" section.
10. Past experience shows that the most frequent errors are incorrect components, improper connections, and poor layout.

Performance Evaluation

This section shows a sample evaluation results as a reference guide for evaluating a DC-DC Converter using the RC5050 on a Pentium Pro motherboard.

Load Regulation

| VID | I_{load} (A) | V_{out} (V) |
|-----------------------------|----------------|---------------|
| 10100 | 0.5 | 3.0904 |
| | 1.0 | 3.0825 |
| | 2.0 | 3.0786 |
| | 3.0 | 3.0730 |
| | 4.0 | 3.0695 |
| | 5.0 | 3.0693 |
| | 6.0 | 3.0695 |
| | 7.0 | 3.0695 |
| | 8.0 | 3.0694 |
| | 9.0 | 3.0694 |
| 9.9 | 3.0691 | |
| Load Regulation 0.5A – 9.9A | | 0.70% |

| VID | I_{load} (A) | V_{out} (V) |
|------------------------------|----------------|---------------|
| 10010 | 0.5 | 3.2805 |
| | 1.0 | 3.2741 |
| | 2.0 | 3.2701 |
| | 3.0 | 3.2642 |
| | 4.0 | 3.2595 |
| | 5.0 | 3.2597 |
| | 6.0 | 3.2606 |
| | 7.0 | 3.2611 |
| | 8.0 | 3.2613 |
| | 9.0 | 3.2611 |
| | 10.0 | 3.2607 |
| | 11.0 | 3.2599 |
| | 12.0 | 3.2596 |
| 12.4 | 3.2596 | |
| Load Regulation 0.5A – 12.4A | | 0.64% |

| VID | I _{load} (A) | V _{out} (V) |
|------------------------------|-----------------------|----------------------|
| 11010 | 0.5 | 2.505 |
| | 1.0 | 2.504 |
| | 2.0 | 2.501 |
| | 3.0 | 2.496 |
| | 4.0 | 2.493 |
| | 5.0 | 2.493 |
| | 6.0 | 2.492 |
| | 7.0 | 2.492 |
| | 8.0 | 2.491 |
| | 9.0 | 2.490 |
| | 10.0 | 2.989 |
| | 11.0 | 2.488 |
| | 12.0 | 2.486 |
| | 13.0 | 2.485 |
| 13.9 | 2.484 | |
| Load Regulation 0.5A – 13.9A | | 0.84% |

Note:

Load regulation is expected to be typically around 0.8%. The load regulation performance for this device under evaluation is excellent.

Output Voltage Load Transients Due to Load Current Step

This test is performed using Intel P6.0/P6S/P6T Voltage Transient Tester.

| | | | |
|--------------------------|------------|----------|---|
| Low to High Current Step | 0.5A-9.9A | -76.0mV | Refer to Attachment A for Scope Picture |
| High to Low Current Step | 9.9A-0.5A | +70mV | Refer to Attachment B for Scope Picture |
| Low to High Current Step | 0.5A-12.4A | -97.6mV | Refer to Attachment C for Scope Picture |
| High to Low Current Step | 12.4A-0.5A | +80.0mV | Refer to Attachment D for Scope Picture |
| Low to High Current Step | 0.5A-13.9A | -99.2mV | Refer to Attachment E for Scope Picture |
| High to Low Current Step | 13.9A-0.5A | +105.2mV | Refer to Attachment F for Scope Picture |

Note:

Transient voltage is recommended to be less than 4% of the output voltage. The performance of the device under evaluation is significantly better than a typical VRM.

Input Ripple and Power on Input Rush Current

| | | |
|-------------------|-----------------------------|---|
| $I_{load} = 9.9A$ | Input Ripple Voltage = 15mV | Refer to Attachment G for Scope Picture |
|-------------------|-----------------------------|---|

Power on Input Rush Current was not measured on the motherboard because we did not want to cut the 5V trace and insert a current probe in series with the supply. However, with the input filter design, the Input Rush Current is well within specification.

Note:

Excellent input ripple voltage. Input ripple voltage is recommended to be less than 5% of the output voltage.

Component Case Temperature

| Device | Description | Case Temperature $I_{load} = 9.9A$ (°C) | Case Temperature $I_{load} = 12.4A$ (°C) | Case Temperature $I_{load} = 13.9A$ (°C) |
|--------|-----------------------|---|--|--|
| Q3A | MOSFET K1388 | 57 | 63 | 66.3 |
| Q3B | MOSFET K1388 | 58 | 64 | 66.6 |
| L1 | Inductor, Unknown | 53 | 56 | 61.2 |
| Q2 | Schottky Diode 2048CT | 66 | 70 | 87 |
| IC | Raytheon's RC5050 | 52 | 54 | 58 |
| Cin | Input Cap. 1000µF | 38.2 | 36.8 | 39 |
| Cout | Output Cap. 1500µF | 35 | 34.8 | 38.2 |

Note:

The values for case temperatures are within guidelines. That is, case temperatures for all components should be below 105°C @25°C Ambient.

Evaluation Summary

The on-board DC-DC converter is fully functional. It has excellent load regulation, transient response, and input voltage ripple.

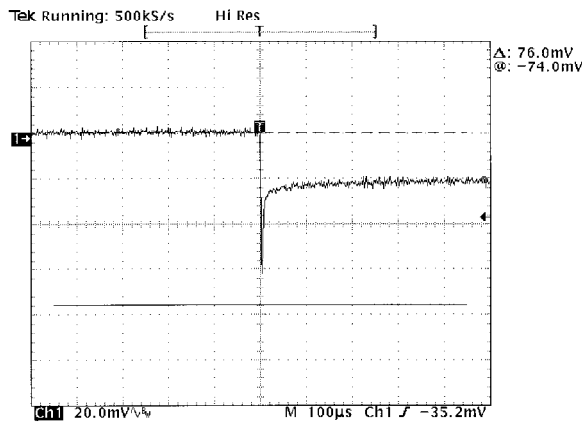

Attachment A

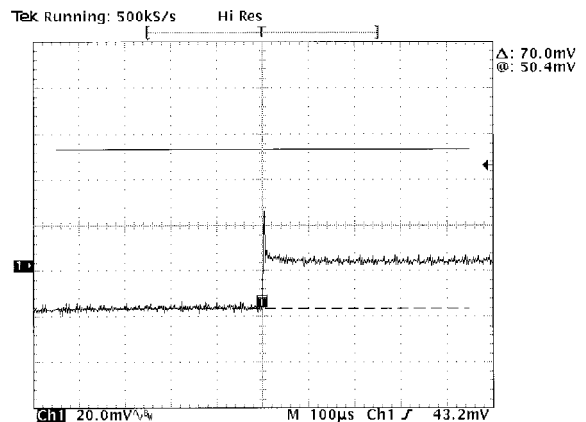

Attachment B

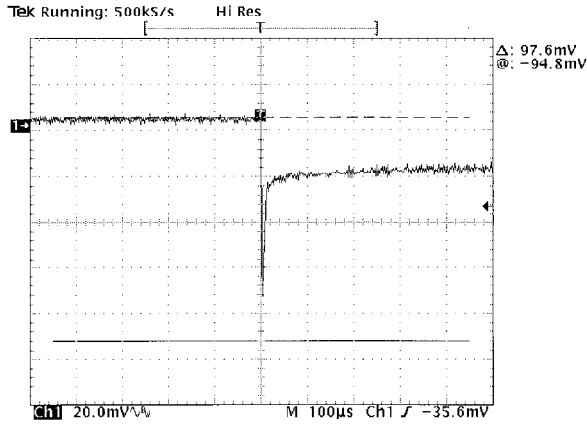

Attachment C

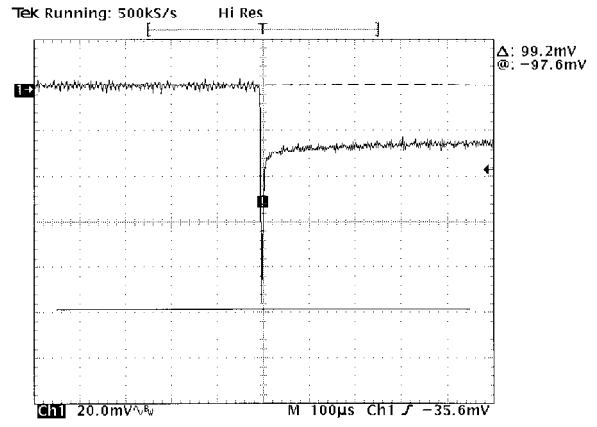

Attachment E

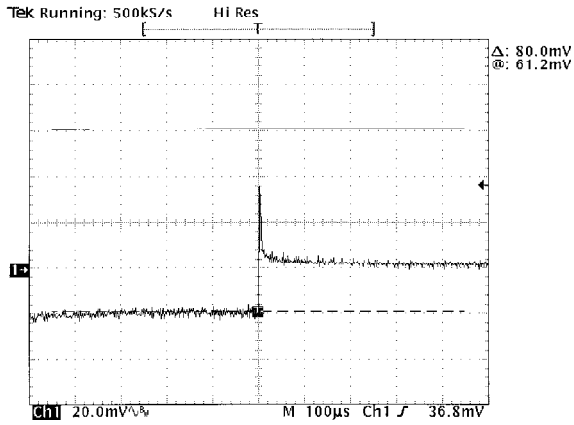

Attachment D

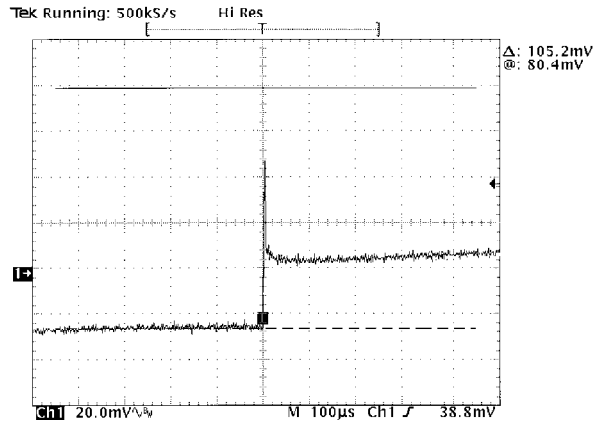

Attachment F

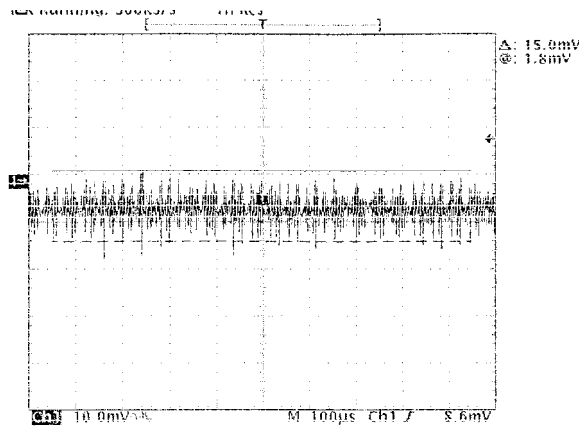

Attachment G

Summary

This application note covers many aspects of the RC5050 and RC5051 for implementation of a DC-DC converter on a Pentium Pro motherboard. A detailed discussion includes the processor power requirements, a description of the RC5050 and RC5051, design considerations and components selection, layout guidelines and considerations, guidelines for debugging, and performance evaluations.

RC5050 Evaluation Board

Raytheon Electronics provides an evaluation board to verify system level performance of the RC5050. The evaluation board serves as a guide to performance expectations when using the supplied external components and PCB layout.

Call Raytheon Electronics local Sales Office or the Marketing department at 415-966-7819 for an evaluation board.

Appendix A

Directory of Component Suppliers

Dale Electronics, Inc.
E. Hwy. 50, PO Box 180
Yankton, SD 57078-0180
PH: (605) 665-9301

Fuji Electric
Collmer Semiconductor Inc.
14368 Proton Rd.
Dallas, Texas 75244
PH: (214)233-1589

General Instrument
Power Semiconductor Division
10 Melville Park Road
Melville, NY 11747
PH: (516) 847-3000

Hoskins Manufacturing Co.
(Copel Resistor Wire)
10776 Hall Road
Hamburg, MI 48139-0218
PH: (313) 231-1900

Intel Corp.
5200 NE Elam Young Pkwy.
Hillsboro, OR. 97123
PH: (800) 843-4481 Tech. Support
for Power Validator

International Rectifier
233 Kansas St.
El Segundo, CA 90245
PH: (310) 322-3331

IRC Inc.
PO Box 1860
Boone, NC 28607
PH: (704) 264-8861

Motorola Semiconductors
PO Box 20912
Phoenix, Arizona 85036
PH:(602) 897-5056

National Semiconductor
2900 Semiconductor Drive
Santa Clara, CA 95052-8090
PH: (800) 272-9959

Nihon Inter Electronics Corp.
Quantum Marketing Int'l, Inc.
12900 Rolling Oaks Rd.
Caliente, CA 93518
PH: (805) 867-2555

Panasonic Industrial Co.
6550 Katella Avenue
Cypress, CA 90630
PH: (714) 373-7366

Pulse Engineering
12220 World Trade Drive
San Diego, CA 92128
PH: (619) 674-8100

Sanyo Energy USA
2001 Sanyo Avenue
San Diego, CA 92173
PH: (619) 661-6620

Siliconix
Temic Semiconductors
2201 Laurelwood Road
Santa Clara, CA 95056-1595
PH: (800) 554-5565

Sumida Electric USA
5999 New Wilke Road Suite #110
Rolling Meadows, IL 60008
PH: (708) 956-0702

Xicon Capacitors
PO Box 170537
Arlington, Texas 76003
PH:(800) 628-0544

LIFE SUPPORT POLICY

FAIRCHILD'S PRODUCTS ARE NOT AUTHORIZED FOR USE AS CRITICAL COMPONENTS IN LIFE SUPPORT DEVICES OR SYSTEMS WITHOUT THE EXPRESS WRITTEN APPROVAL OF THE PRESIDENT OF FAIRCHILD SEMICONDUCTOR CORPORATION. As used herein:

1. Life support devices or systems are devices or systems which, (a) are intended for surgical implant into the body, or (b) support or sustain life, and (c) whose failure to perform when properly used in accordance with instructions for use provided in the labeling, can be reasonable expected to result in a significant injury of the user.
2. A critical component in any component of a life support device or system whose failure to perform can be reasonably expected to cause the failure of the life support device or system, or to affect its safety or effectiveness.

Fairchild Semiconductor Corporation
Americas
Customer Response Center
Tel:1-888-522-5372

Fairchild Semiconductor Europe
Fax: +49 (0) 1 80-530 85 86
Email: europe.support@nsc.com
Deutsch Tel: +49 (0) 8 141-35-0
English Tel: +44 (0) 1 793-85-68-56
Italy Tel: +39 (0) 2 57 5631

Fairchild Semiconductor Hong Kong Ltd.
13th Floor, Straight Block,
Ocean Center, 5 Canto Rd.
Tsimshatsui, Kowloon
Hong Kong
Tel:+852 2737-7200
Fax:+852 2314-0061

National Semiconductor Japan Ltd.
Tel:81-3-5620-6175
Fax:81-3-5620-6179

Free Manuals Download Website

<http://myh66.com>

<http://usermanuals.us>

<http://www.somanuals.com>

<http://www.4manuals.cc>

<http://www.manual-lib.com>

<http://www.404manual.com>

<http://www.luxmanual.com>

<http://aubethermostatmanual.com>

Golf course search by state

<http://golfingnear.com>

Email search by domain

<http://emailbydomain.com>

Auto manuals search

<http://auto.somanuals.com>

TV manuals search

<http://tv.somanuals.com>