

Friedrich

Room Air Conditioner Service and Parts Manual

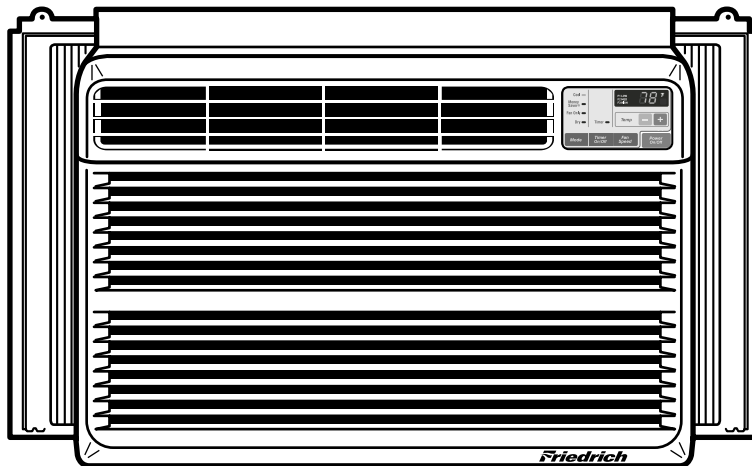

115Volts • ZQ08B10 • ZQ10B10 • CP08A10 • CP10A10 • CP12A10

ZQ08/10;CP08/10/12 (06/05)

CONTENTS

1. PREFACE

1.1 SAFETY PRECAUTIONS.....	2
1.2 INSULATION RESISTANCE TEST.....	2
1.3 SPECIFICATIONS.....	3
1.4 FEATURES.....	4
1.5 CONTROL LOCATIONS	4

2. DISASSEMBLY INSTRUCTIONS

2.1 MECHANICAL PARTS	6
2.1.1 FRONT GRILLE	6
2.1.2 CABINET	6
2.1.3 CONTROL BOX	6
2.2 AIR HANDLING PARTS	7
2.2.1 AIR GUIDE AND TURBO FAN.....	7
2.2.2 FAN	7
2.2.3 SHROUD	8
2.3 ELECTRICAL PARTS.....	8
2.3.1 OVERLOAD PROTECTOR	8
2.3.2 COMPRESSOR.....	8
2.3.3 CAPACITOR.....	9
2.3.4 POWER CORD	9
2.3.5 MOTOR	10
2.4 REFRIGERATION CYCLE	10
2.4.1 CONDENSER.....	10
2.4.2 EVAPORATOR.....	10
2.4.3 CAPILLARY TUBE	11

3. TROUBLESHOOTING GUIDE

3.1 OUTSIDE DIMENSIONS.....	13
3.2 PIPING SYSTEM.....	14
3.3 TROUBLESHOOTING GUIDE	15

4. SCHEMATIC DIAGRAM.....19

5. EXPLODED VIEW

6. REPLACEMENT PARTS LIST.....21

1. PREFACE

This **SERVICE MANUAL** provides various service information, including the mechanical and electrical parts etc. This room air conditioner was manufactured and assembled under a strict quality control system. The refrigerant is charged at the factory. Be sure to read the safety precautions prior to servicing the unit.

1.1 SAFETY PRECAUTIONS

1. When servicing, turn the unit Off and unplug the power cord.
2. Observe the original lead dress.
If a short circuit is found, replace all parts which have been overheated or damaged by the short circuit.
3. After servicing, make an insulation resistance test to prevent the customer from being exposed to shock hazards.

1.2 INSULATION RESISTANCE TEST

1. Unplug the power cord and connect a jumper between 2 pins (black and white).
2. The grounding conductor (green or green and yellow) is to be open.
3. Measure the resistance value with an ohm meter between the jumpered lead and each exposed metallic part on the equipment at each working status.
4. The value should be over 1 MΩ.

1.3 SPECIFICATIONS

1.3.1 FOR ZQ08B 10,ZQ10B 10,CP08A10,CP 10A10,CP12A10

ITEMS		MODELS				
		ZQ08B 10	ZQ10B 10	CP08A10	CP10A10	CP12A10
POWER SUPPLY		1ø, 115V, 60HZ				
COOLING CAPACITY	(Btu/h)	7,800	10,000	7,800	10,000	12,000
INPUT	(W)	800	1,020	730	930	1,110
RUNNING CURRENT	(A)	7.6	9.2	6.6	8.5	10.2
E.E.R	(BTU/W.h)	9.7	9.8	10.8		
OPERATING CONDITION	INDOOR (iC)	26.7(DB)* 19.4(WB)**				
	OUTDOOR (iC)	35(DB)* 23.9(WB)**				
REFRIGERANT (R-22) CHARGE		300g(10.6oz)	520g(18.3oz)	420g(14.8oz)	525g(18.5oz)	510g(18.0oz)
EVAPORATOR		2 ROW 11STACKS	3 ROW 11STACKS		2 ROW 10STACKS	3 ROW 12STACKS
CONDENSER		2 ROW 16STACKS	2 ROW 16STACKS(L)		2 ROW 17STACKS	2 ROW 17STACKS(L)
FAN, INDOOR		TURBO FAN				
FAN, OUTDOOR		PROPELLER TYPE FAN WITH SLINGER RING				
FAN SPEEDS, FAN/COOLING		2/3		3/3		
FAN MOTOR		6 POLES				
OPERATION CONTROL		ROTARY SWITCH		REMOTE CONTROLLER		
ROOM TEMP. CONTROL		THERMOSTAT		THERMISTOR		
AIR DIRECTION CONTROL		VERTICAL LOUVER (RIGHT & LEFT)				
		HORIZONTAL LOUVER (UP & DOWN)				
CONSTRUCTION		SLIDE IN-OUT CHASSIS				
PROTECTOR	COMPRESSOR	OVERLOAD PROTECTOR				
	FAN MOTOR	INTERNAL THERMAL PROTECTOR				
POWER CORD		(3 WIRE WITH GROUDING)				
		ATTACHMENT PLUG (CORD-CONNECTED TYPE)				
DRAIN SYSTEM		DRAIN PIPE OR SPLASHED BY FAN SLINGER				
NET WEIGHT	(lbs/kg)	62/28				
OUTSIDE DIMENSION (W x H x D)	(inch)	20 ³ / ₃₂ X 13 ²⁹ / ₃₂ X 19 ³ / ₈				
	(mm)	510 x 354 x 490				

* DB: Dry Bulb

**WB: Wet Bulb

1.4 FEATURES

- Designed for COOLING ONLY.
- Powerful and whispering cooling.
- Slide-in and slide-out chassis for the simple installation and service.
- Low air-intake, top cooled-air discharge.
- Built-in adjustable Thermistor
- Washable one-touch filter
- Compact size
- Reliable and efficient rotary compressor is equipped.

1.5 CONTROL LOCATIONS

• THERMOSTAT (Fig A)

Thermostat will automatically control the temperature of the discharge air. For a cooler setting, turn clockwise, For a warmer setting, turn counter clockwise.

• OPERATION (Fig A)

OFF : Turns the air conditioner off.

MED FAN : Medium fan speed without cooling.

LOW FAN : Low fan speed without cooling.

HIGH COOL : Cooling with the high fan speed.

MED COOL : Cooling with the medium fan speed.

LOW COOL : Cooling with the low fan speed.

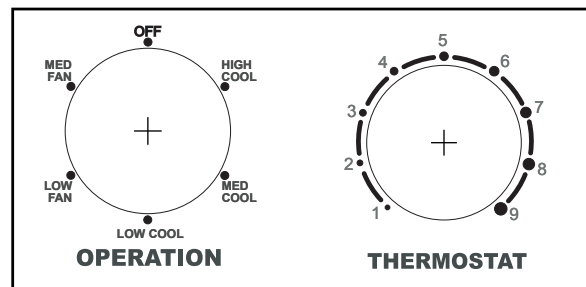

Fig A

DISPLAY

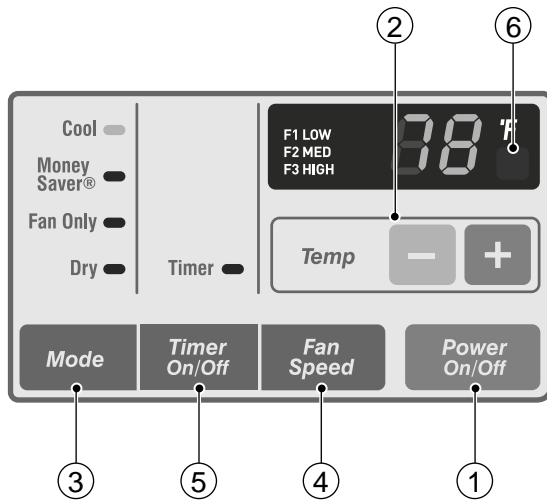

Fig B

REMOTE CONTROL

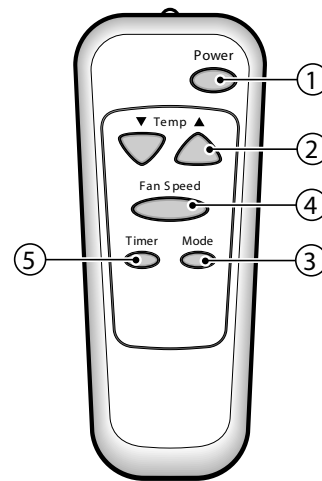

Fig C

Precaution: The Remote Control unit will not function properly if strong light strikes the sensor window of the air conditioner or if there are obstacles between the Remote Control unit and the air conditioner.

Refer to Fig B&Fig C

1 POWER BUTTON

To turn the air conditioner ON. To turn the air conditioner OFF, push the button again. This button takes priority over any other buttons.

2 TEMPERATURE SETTING BUTTON

This button can automatically control temperature of the room. The temperature can be set within a range of 60°F to 86°F by 1°F.

3 OPERATION MODE SELECTION BUTTON

Every time you push this button, it will shift operation between COOL, ENERGY SAVER, FAN and DRY modes.

- Money Saver: If Money Save mode is selected, the fan stops when the compressor stops cooling.

Approximately every 3 minutes the fan will turn on and check the room air to determine if cooling is needed.

4 FAN SPEED SELECTOR

Every time you push this button, it will shift fan speeds, as follows.

(Hi → Low → Med → Hi → Low →...)

5 ON/OFF TIMER BUTTON

ON - When the air conditioner is off, it can be set to automatically come on in 1 to 12 hours from its previous setting.

Each touch will increase the timer by 1 hour.

OFF - When the air conditioner is on, it can be set to automatically turn off in 1 to 12 hours. Each touch will increase the timer by 1 hour. After the timer has been on for 30min, the temperature will automatically rise 2°F, and after another 30min, it will rise 2°F again. The temperature will stay the same until the timer goes off.

To cancel the timer, press the timer pad until the display time disappears.

2. DISASSEMBLY INSTRUCTIONS

— Before the following disassembly, set POWER SWITCH to OFF and disconnect the power cord.

2.1 MECHANICAL PARTS

2.1.1 FRONT GRILLE

1. Open the Inlet grille downward and remove the air filter.
2. Remove the screw which fastens the front grille.(See Figure 1)
3. Pull the front grille from the right side.
4. Remove the front grille.(There are 4 hooks.)
5. Re-install the components by referring to the removal procedure, above.

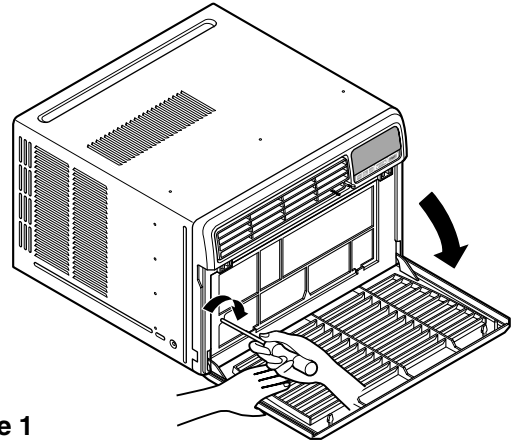

Figure 1

2.1.2 CABINET

1. After disassembling the FRONT GRILLE, remove the 2 screws which fasten the cabinet at both sides.
2. Remove the 2 screws which fasten the cabinet at back.
3. Pull the base pan forward. (See Figure 2)
4. Remove the cabinet.
5. Re-install the components by referring to the removal procedure, above.

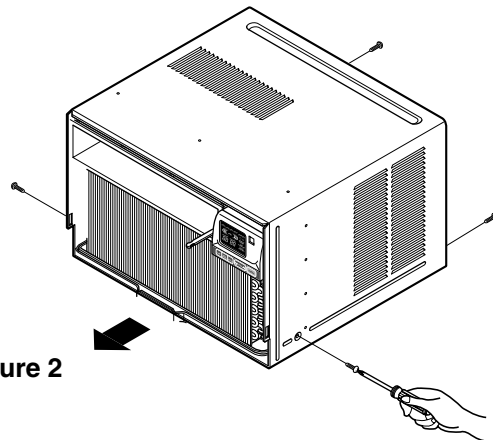

Figure 2

2.1.3 CONTROL BOX

1. Remove the front grille. (Refer to section 2.1.1)
2. Remove the cabinet. (Refer to section 2.1.2)
3. Remove the 2 screws which fasten the power cord.
4. Disconnect the grounding screw from the evaporator channel.
5. Remove the 1 screw which fastens the control box cover.
6. Remove the housing which connects PCB(CP 08/10/12) or connector(ZQ 08/10) and motor wire in the control box.
7. Remove the nut which fastens the terminal cover.
8. Remove the terminal cover.
9. Remove all the leads from the overload protector.
10. Discharge the capacitor by placing a 20,000 ohm resistor across the capacitor terminals.
11. Raise the control box upward completely. (See Figure 3)
12. Re-install the components by referring to the removal procedure, above.
(Refer to the circuit diagram found on page 27 in this manual and on the control box.)

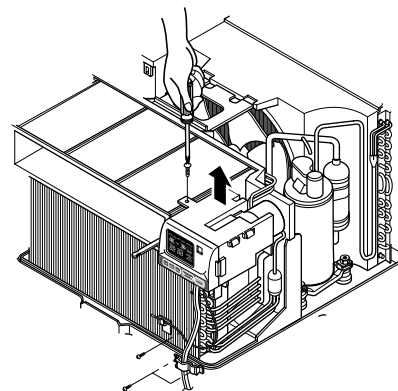

Figure 3

2.2 AIR HANDLING PARTS

2.2.1 AIR GUIDE AND TURBO FAN

1. Remove the front grille. (Refer to section 2.1.1)
2. Remove the cabinet. (Refer to section 2.1.2)
3. Remove the control box. (Refer to section 2.1.3)
4. Remove the 4 screws which fasten the brace.
5. Remove the brace.
6. Remove the 2 screws which fasten the air guide upper.
7. Remove the air guide upper.(See figure 4)
8. Remove the 2 screws which fasten the evaporator.
9. Move the evaporator forward pulling it upward slightly. (See Figure 5)
10. Pull the hook out of orifice by pushing the tabs and remove it. (See Figure 6)
11. Using pliers remove the clamp secures the turbo fan.
12. Remove the turbo fan.
13. Remove the 2 screws which fasten the air guide to the base pan.
14. Move the air guide backward, and pull out from the base pan.(Move the air guide lower carefully.)
15. Re-install the components by referring to the removal procedure, above.

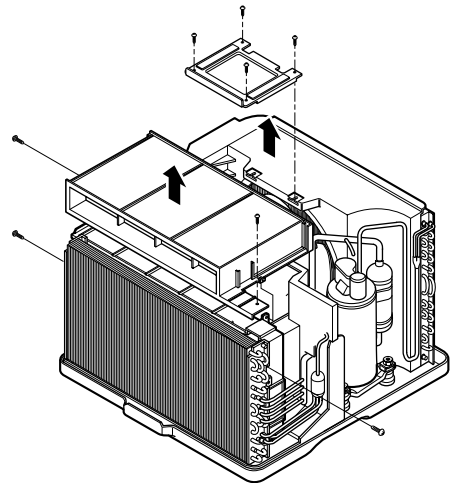

Figure 4

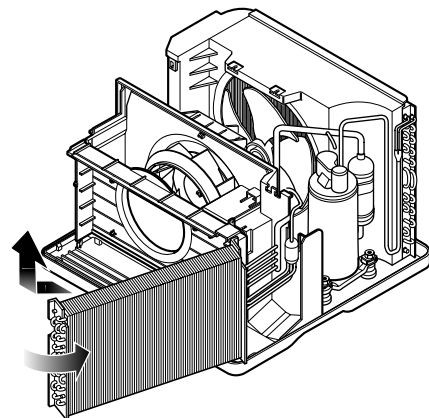

Figure 5

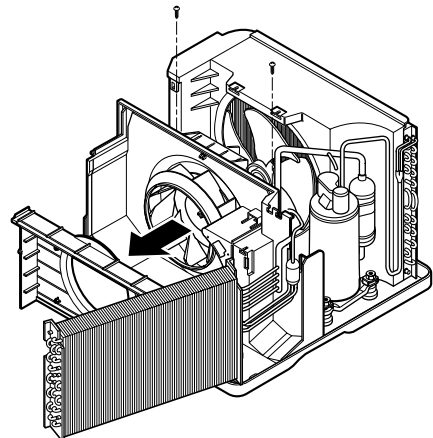

Figure 6

2.2.2 FAN

1. Remove the cabinet. (Refer to section 2.1.2)
2. Remove the brace (Refer to section 2.2.1)
3. Remove the 5 screws which fasten the condenser.
4. Move the condenser to the left carefully.
5. Remove the clamp which secures the fan.
6. Remove the fan. (See Figure 7)
7. Re-install by referring to the removal procedure.

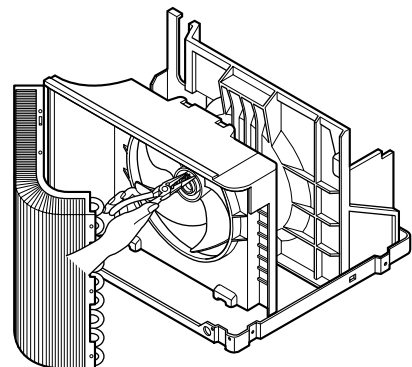

Figure 7

2.2.3 SHROUD

1. Remove the fan. (Refer to section 2.2.2)
2. Remove the shroud. (See Figure 8)
3. Re-install the components by referring to the removal procedure, above.

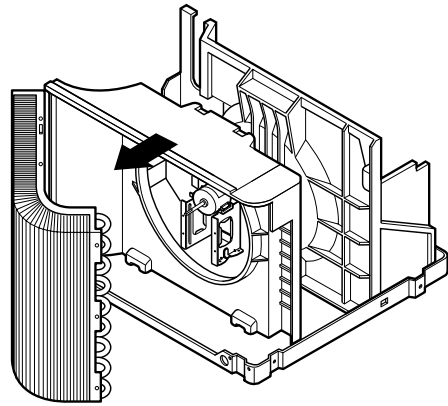

Figure 8

2.3 ELECTRICAL PARTS

2.3.1 OVERLOAD PROTECTOR

1. Remove the cabinet. (Refer to section 2.1.2)
2. Remove the nut which fastens the terminal cover.
3. Remove the terminal cover. (See Figure 9)
4. Remove all the leads from the overload protector.
5. Remove the overload protector.
6. Re-install the components by referring to the removal procedure, above.

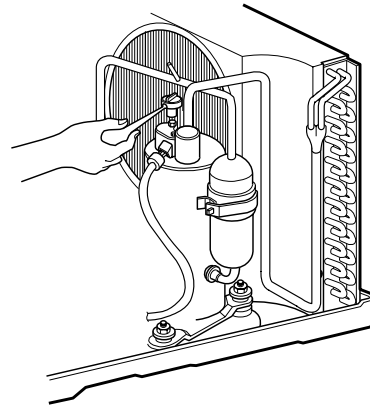

Figure 9

2.3.2 COMPRESSOR

1. Remove the cabinet. (Refer to section 2.1.2)
2. Discharge the refrigerant system using a Freon™ Recovery System.
If there is no valve to attach the recovery system to, install one (such as a WATCO A-1) before venting the Freon™. Remove the valve when finished
3. Remove the overload protector. (Refer to section 2.3.1)
4. After purging the unit completely, unbraid the suction and discharge tubes at the compressor connections.
5. Remove the 3 nuts and the 3 washers which fasten the compressor.
6. Remove the compressor. (See Figure 10)
7. Re-install the components by referring to the removal procedure, above.

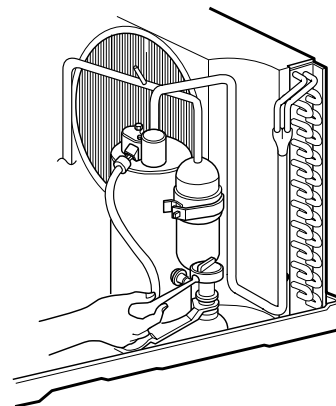

Figure 10

2.3.3 CAPACITOR

1. Remove the control box. (Refer to section 2.1.3)
2. Open the top cover from the control box.
(See Figure 11)
3. Pull out the capacitor from the control box.
4. Disconnect all the leads of capacitor terminals.
5. Re-install the components by referring to the removal procedure, above.

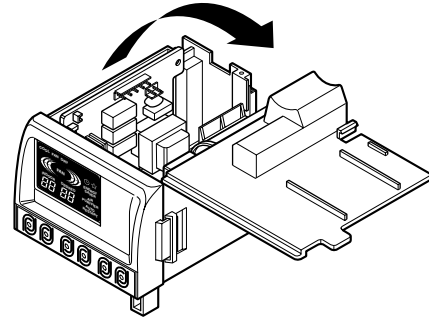

Figure 11

2.3.4 POWER CORD

1. Remove the control box. (Refer to section 2.1.3)
2. Open the top cover from the control box.
(Refer to section 2.3.3)
3. Disconnect the front panel from the control box.
(See Figure 12)
4. Disconnect the 2 receptacles and remove the grounding screw.
5. Pull out the power cord.
6. Re-install the component by referring to the removal procedure, above.
(Use only one ground-marked hole for ground connection.)
7. If the supply cord of this appliance is damaged, it must be replaced by the factory specified cord.

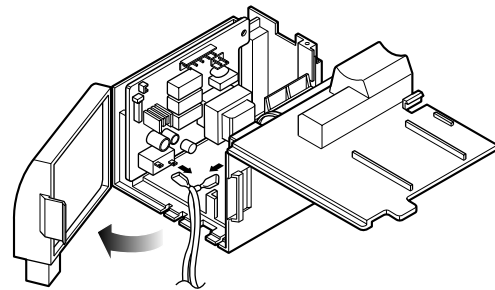
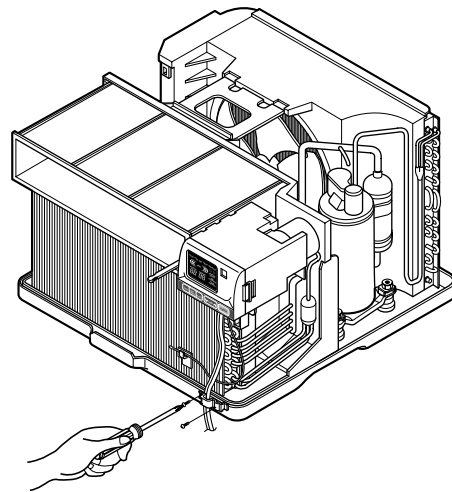

Figure 12

2.3.5 MOTOR

1. Remove the cabinet. (Refer to section 2.1.2)
2. Remove the turbo fan. (Refer to section 2.2.1)
3. Remove the fan. (Refer to section 2.2.2)
4. Remove the 4 screws which fasten the motor to the air guide. (See Figure 13)
5. Remove the motor.
6. Re-install the components by referring to the removal procedure, above.(See Figure 13)

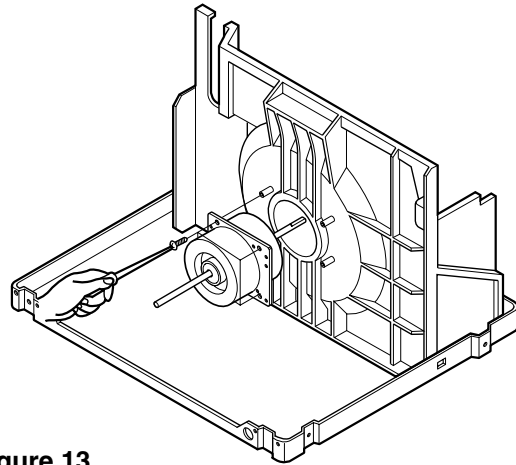

Figure 13

2.4 REFRIGERATING CYCLE

2.4.1 CONDENSER

CAUTION

Discharge the refrigerant system using a Freon™ Recovery System. If there is no valve to attach the recovery system, install one (such as a WATCO A-1) before venting the Freon™. Remove the valve when finished.

1. Remove the cabinet. (Refer to section 2.1.2)
2. Remove the 5 screws which fasten the brace.(Refer to section 2.2.1)
3. Remove the 5 screws which fasten the condenser and shroud.
4. After discharging the refrigerant completely, unbrazed the interconnecting tube at the condenser connections.
5. Remove the condenser.
6. Re-install the components by referring to notes. (See Figure 14)

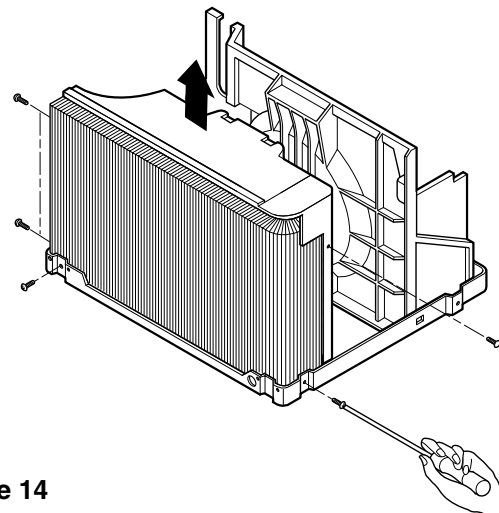

Figure 14

2.4.2 EVAPORATOR

1. Remove the control box.(Refer to section 2.1.3)
2. Remove the air guide upper. (Refer to section 2.2.1)
3. Remove the 2 screws which fasten the evaporator.
4. Move the evaporator sideways carefully. (Refer to section 2.2.1)
5. After discharging the refrigerant completely, unbrazed the interconnecting tube at the evaporator connections.
6. Remove the evaporator.
7. Re-install the components by referring to notes. (See Figure 15)

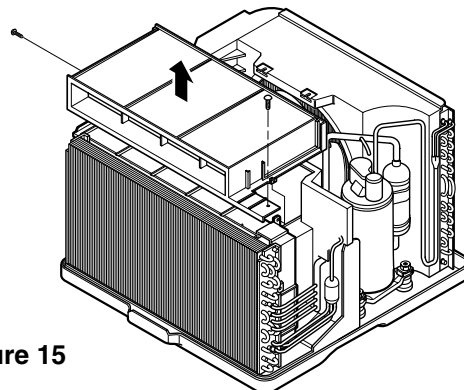

Figure 15

2.4.3 CAPILLARY TUBE

1. Remove the cabinet. (Refer to section 2.1.2)
2. After discharging the refrigerant completely, unbraid the interconnecting tube at the capillary tube. (See caution on previous page)
3. Remove the capillary tube.
4. Re-install the components by referring to notes.

NOTES

— Replacement of the refrigeration cycle.

1. When replacing the refrigeration cycle, be sure to Discharge the refrigerant system using a Freon™ recovery System.
If there is no valve to attach the recovery system, install one (such as a WATCO A-1) before venting the Freon™. Remove the valve when finished.
 2. After discharging the unit completely, remove the desired component, and unbraid the pinch-off tubes.
 3. Solder service valves into the pinch-off tube ports, leaving the valves open.
 4. Solder the pinch-off tubes with Service valves.
 5. Evacuate as follows.
 - 1) Connect the vacuum pump, as illustrated figure 16A.
 - 2) Start the vacuum pump, slowly open manifold valves A and B with two full turns counterclockwise and leave the valves open. The vacuum pump is now pulling through valves A and B up to valve C by means of the manifold and entire system.
 6. Recharge as follows :
 - 1) Refrigeration cycle systems are charged from the High-side. If the total charge cannot be put in the High-side, the balance will be put in the suction line through the access valve which you installed as the system was opened.
 - 2) Connect the charging cylinder as shown in figure 16B.
With valve C open, discharge the hose at the manifold connection.
 - 3) Open valve A and allow the proper charge to enter the system. Valve B is still closed.
 - 4) If more charge is required, the high-side will not take it. Close valve A.
 - 5) With the unit running, open valve B and add the balance of the charge.
 - a. Do not add the liquid refrigerant to the Low-side.
 - b. Watch the Low-side gauge; allow pressure to rise to 30 lbs.
 - c. Turn off valve B and allow pressure to drop.
 - d. Repeat steps b. and c. until the balance of the charge is in the system.
 - 6) When satisfied the unit is operating correctly, use the pinch-off tool with the unit still running and clamp on to the pinch-off tube. Using a tube cutter, cut the pinch-off tube about 2 inches from the pinch-off tool. Use sil-fos solder and solder pinch-off tube closed. Turn off the unit, allow it to set for a while, and then test the leakage of the pinch-off connection.
- 3) Operate the vacuum pump for 20 to 30 minutes, until 600 microns of vacuum is obtained. Close valves A and B, and observe vacuum gauge for a few minutes. A rise in pressure would indicate a possible leak or moisture remaining in the system. With valves A and B closed, stop the vacuum pump.
 - 4) Remove the hose from the vacuum pump and place it on the charging cylinder. See figure 16B.
Open valve C.
Discharge the line at the manifold connection.
 - 5) The system is now ready for final charging.

CAUTION

If high vacuum equipment is used, just crack valves A and B for a few minutes, then open slowly with the two full turns counterclockwise. This will keep oil from foaming and being drawn into the vacuum pump.

Equipment needed: Vacuum pump, Charging cylinder, Manifold gauge, Brazing equipment. Pinch-off tool capable of making a vapor-proof seal, Leak detector, Tubing cutter, Hand Tools to remove components, Service valve.

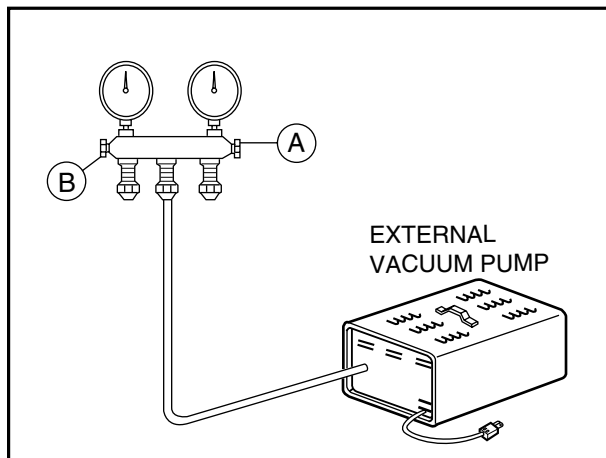
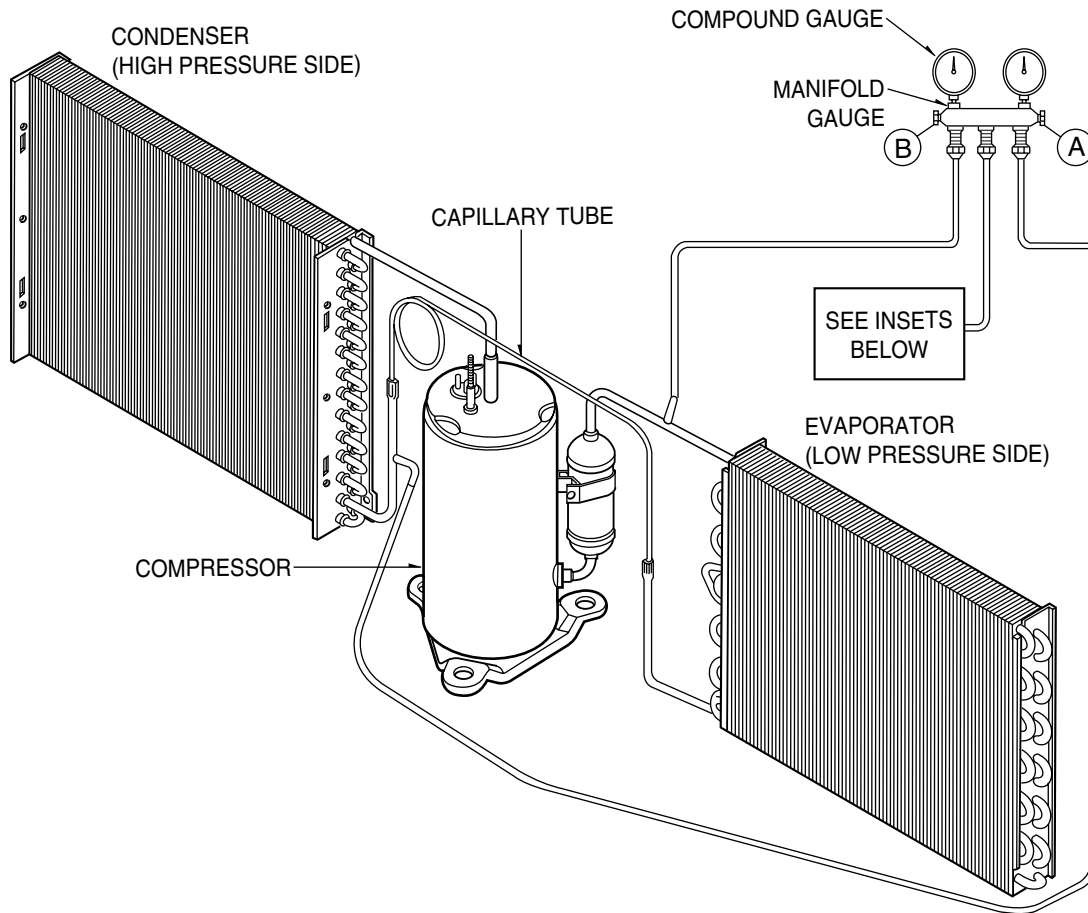

Figure 16A-Pulling Vacuum

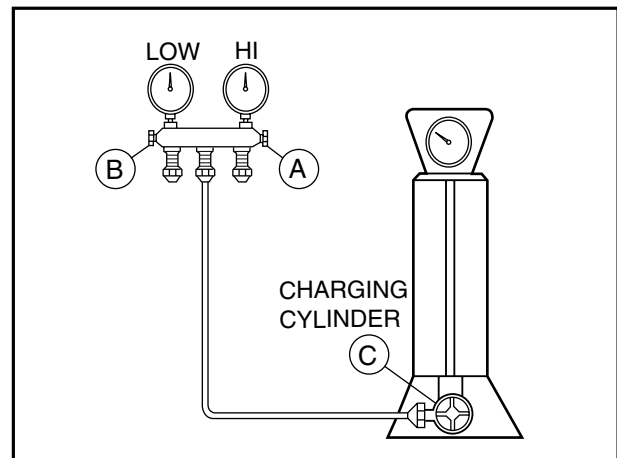

Figure 16B-Charging

3. TROUBLESHOOTING GUIDE

3.1 OUTSIDE DIMENSIONS

unit: mm(inch)

MODEL: ZQ08B10,CP08A10,ZQ10B10

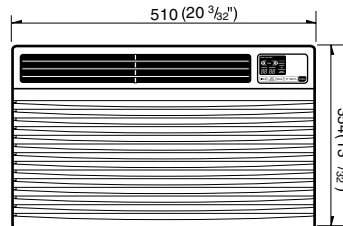
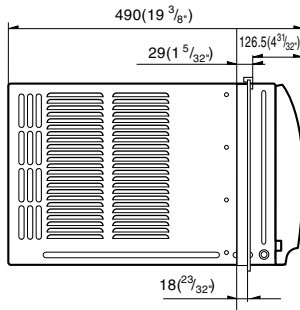

MODEL:CP10A10,CP12A10

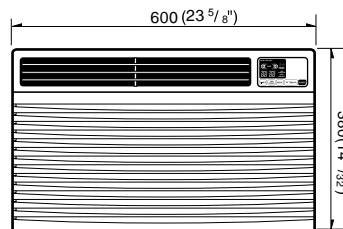
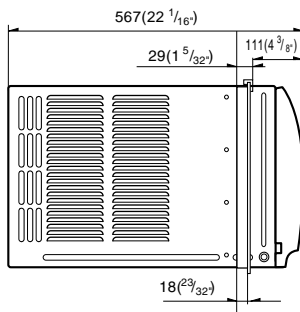

3.2 PIPING SYSTEM

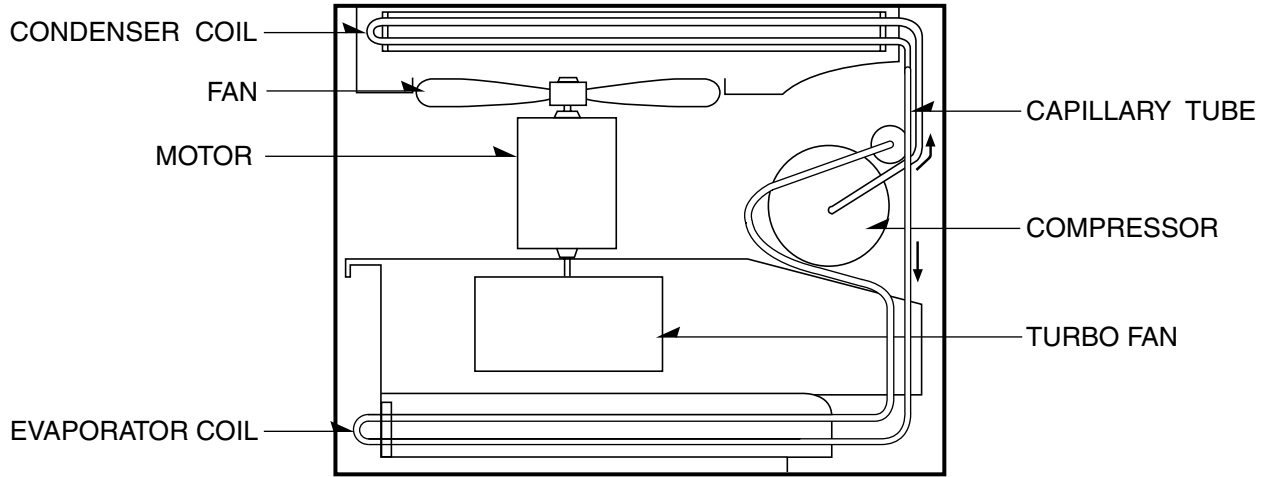
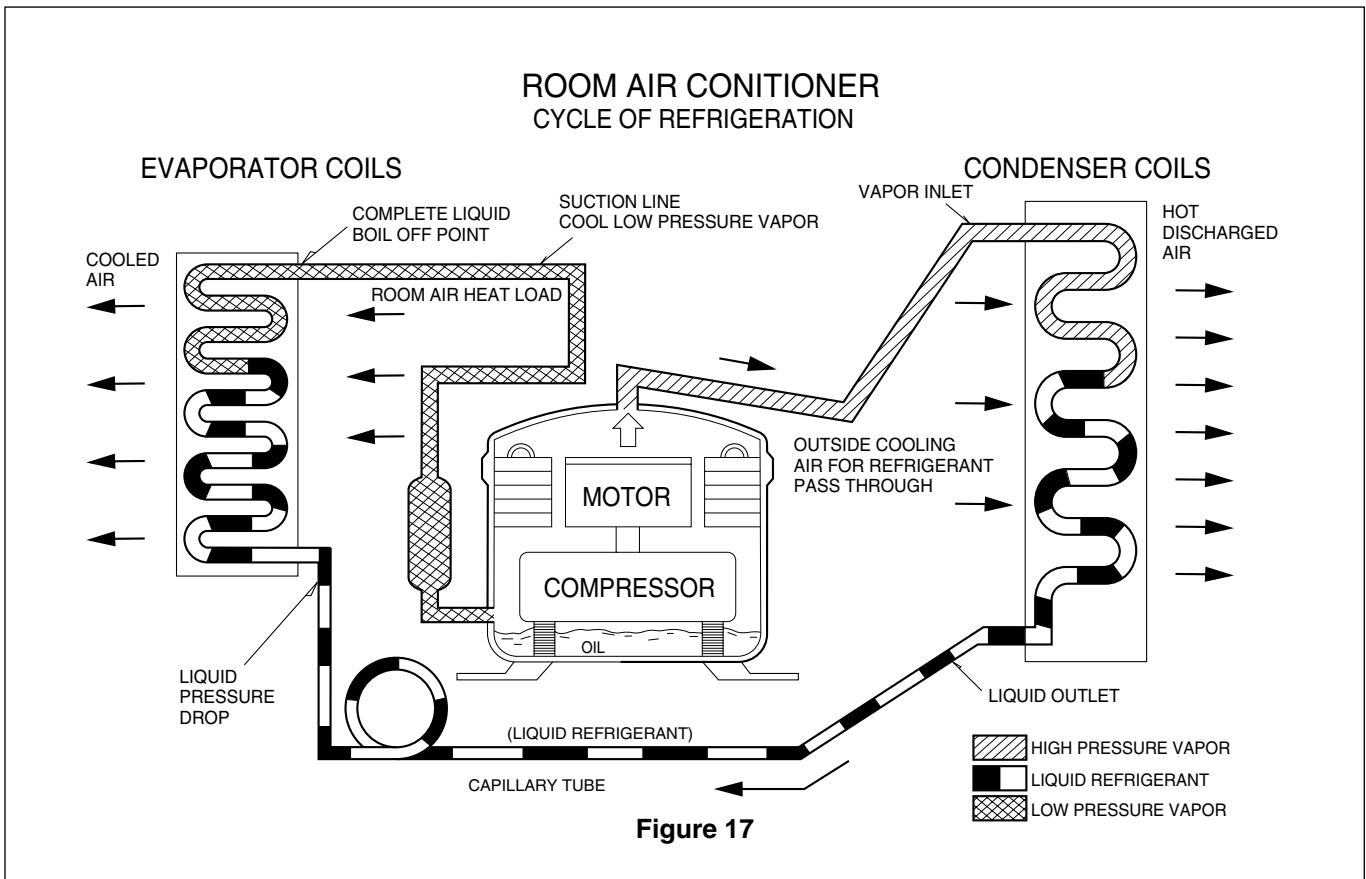

Figure 17 is a brief description of the important components and their function in what is called the refrigeration system. This will help you to understand the refrigeration cycle and the flow of the refrigerant in the cooling cycle.



3.3 TROUBLESHOOTING GUIDE

In general, possible trouble is classified in two kinds.

The one is called Starting Failure which is caused from an electrical defect, and the other is ineffective Air Conditioning caused by a defect in the refrigeration circuit and improper application.

Unit runs but poor cooling.

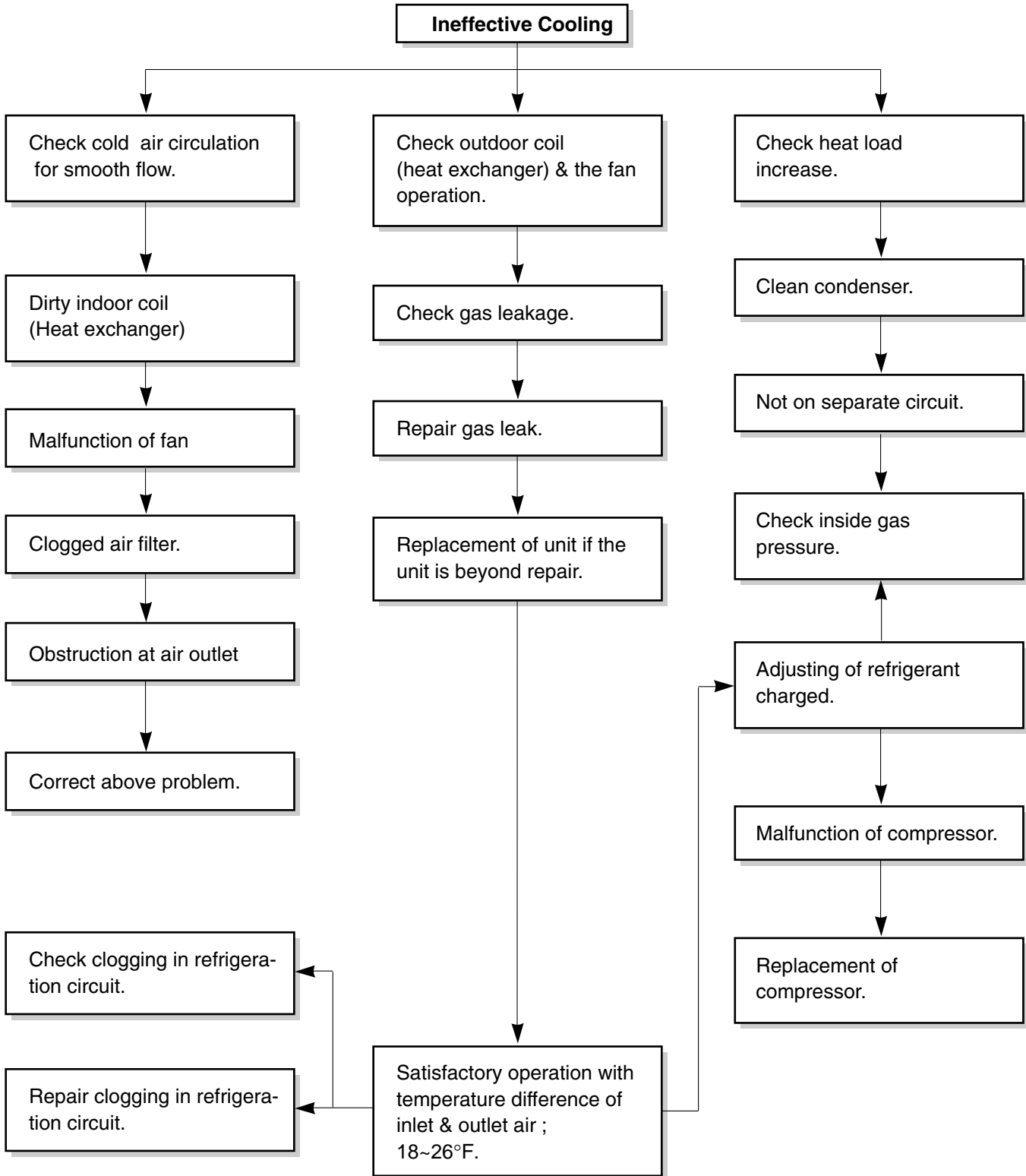

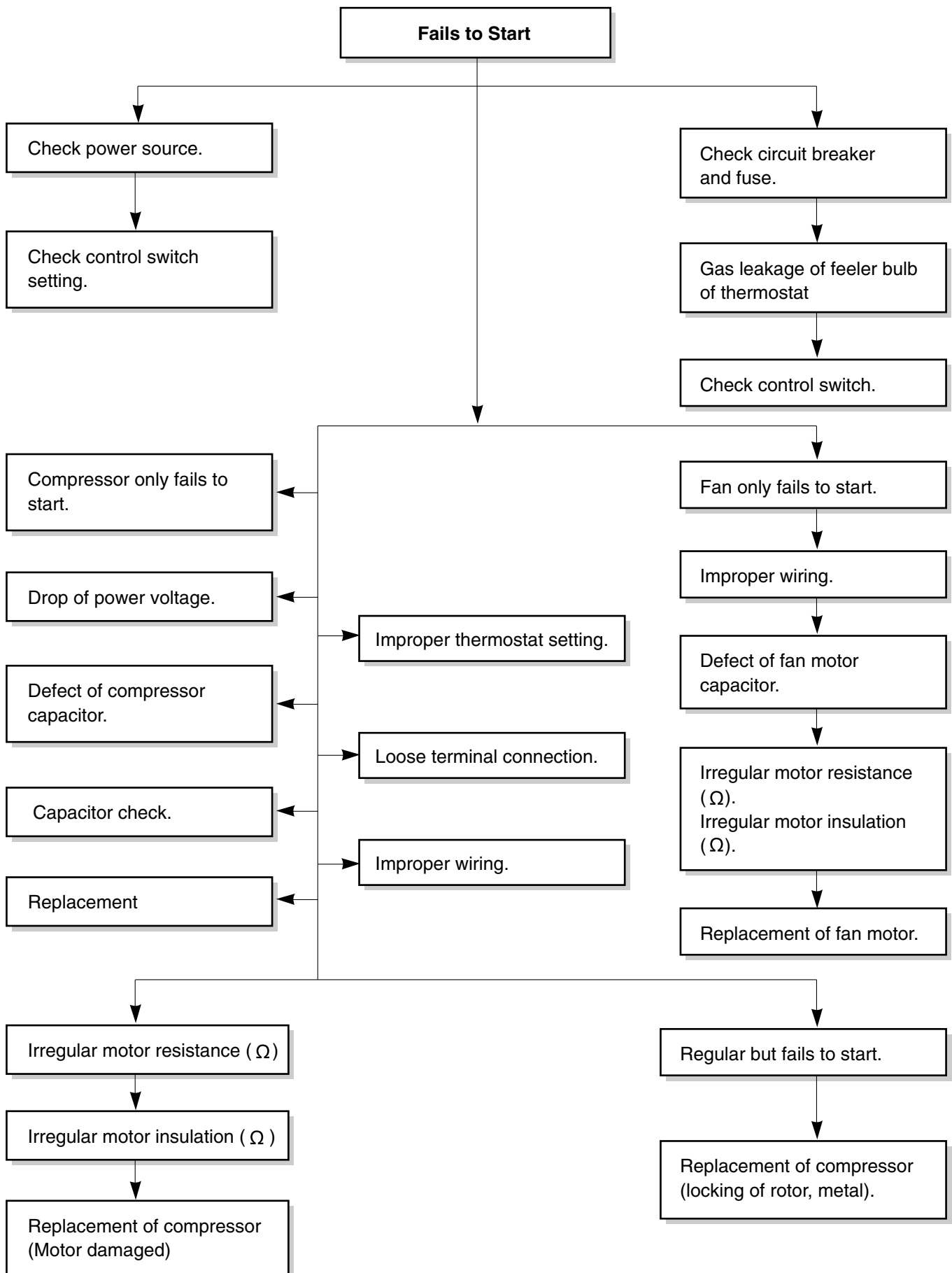

COMPLAINT	CAUSE	REMEDY
Fan motor will not run.	No power	Check voltage at outlet. Correct if none.
	Power supply cord	Check voltage to rotary switch. If none, check power supply cord. Replace cord if circuit is open.
	Rotary switch	Check switch continuity. Refer to wiring diagram for terminal identification. Replace switch if defective.
	Wire disconnected or connection loose	Connect wire. Refer to wiring diagram for terminal identification. Repair or replace loose terminal.
	Capacitor (Discharge capacitor before testing.)	Test capacitor. Replace if not within $\pm 10\%$ of manufacturer's rating. Replace if shorted, open, or damaged.
	Will not rotate	Fan blade hitting shroud or blower wheel hitting scroll. Realign assembly. Units using slinger ring for condenser fan must have $\frac{1}{4}$ to $\frac{5}{16}$ inch clearance to the base. If it hits the base, shim up the bottom of the fan motor with mounting screw(s). Check fan motor bearings; if motor shaft will not rotate, replace the motor.
Fan motor runs intermittently	Revolves on overload.	Check voltage. If not within limits, call an electrician. Test capacitor. Check bearings. Does the fan blade rotate freely? If not, replace fan motor. Pay attention to any change from high speed to low speed. If the speed does not change, replace the motor.
Fan motor noise.	Fan	If cracked, out of balance, or partially missing, replace it.
	Blower	If cracked, out of balance, or partially missing, replace it.
	Loose clamper	Tighten it.
	Worn bearings	If knocking sounds continue when running or loose, replace the motor. If the motor hums or noise appears to be internal while running, replace motor.
Compressor will not run, but fan motor runs.	Voltage	Check voltage. If not within limits, call an electrician.
	Wiring	Check the wire connections, if loose, repair or replace the terminal. If wires are off, refer to wiring diagram for identification, and replace. Check wire locations. If not per wiring diagram, correct.
	Rotary	Check for continuity, refer to the wiring diagram for terminal identification. Replace the switch if circuit is open.

COMPLAINT	CAUSE	REMEDY
Compressor will not run, but fan motor runs.	Thermostat	Check the position of knob. If not at the coldest setting, advance the knob to this setting and restart unit. Check continuity of the thermostat. Replace thermostat if circuit is open.
	Capacitor (Discharge capacitor before servicing.)	Check the capacitor. Replace if not within $\pm 10\%$ of manufacturers rating. Replace if shorted, open, or damaged.
	Compressor	Check the compressor for open circuit or ground. If open or grounded, replace the compressor.
	Overload	Check the compressor overload, if externally mounted. Replace if open. (If the compressor temperature is high, remove the overload, cool it, and retest.)
Compressor cycles on overload.	Voltage	Check the voltage. If not within limits, call an electrician.
	Overload	Check overload, if externally mounted. Replace if open. (If the compressor temperature is high, remove the overload, cool, and retest.)
Compressor cycles on overload.	Fan motor	If not running, determine the cause. Replace if required.
	Condenser air flow restriction	Remove the cabinet. inspect the interior surface of the condenser; if restricted, clean carefully with a vacuum cleaner (do not damage fins) or brush. Clean the interior base before reassembling.
	Condenser fins (damaged)	If condenser fins are closed over a large area on the coil surface, head pressures will increase, causing the compressor to overload. Straighten the fins or replace the coil.
Compressor cycles on overload.	Capacitor	Test capacitor.
	Wiring	Check the terminals. If loose, repair or replace.
	Refrigerating system	Check the system for a restriction.
Insufficient cooling or heating	Air filter	If restricted, clean or replace.
	Exhaust damper door	Close if open.
	Unit undersized	Determine if the unit is properly sized for the area to be cooled.
Excessive noise	Blower or fan	Check the set screw or clamp. If loose or missing, correct. If the blower or fan is hitting air guide, rearrange the air handling parts.
	Copper tubing	Remove the cabinet carefully and rearrange tubing not to contact cabinet, compressor, shroud, and barrier.

4. SCHEMATIC DIAGRAM

MODEL: CP08A10, CP10A10, CP12A10

MODEL: ZQ08B10,ZQ10B10

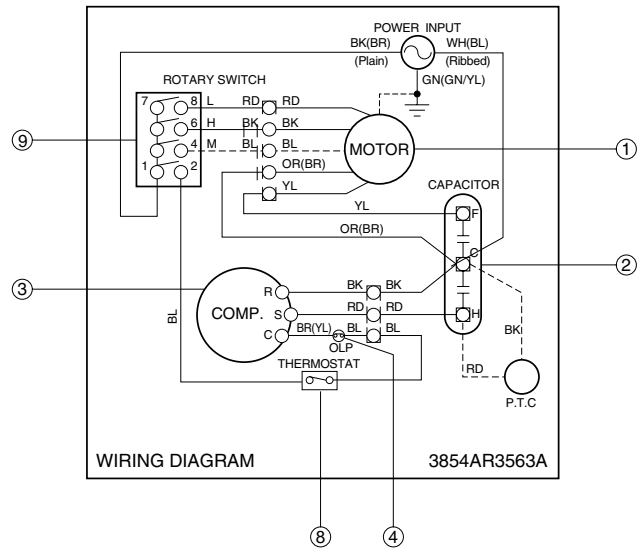
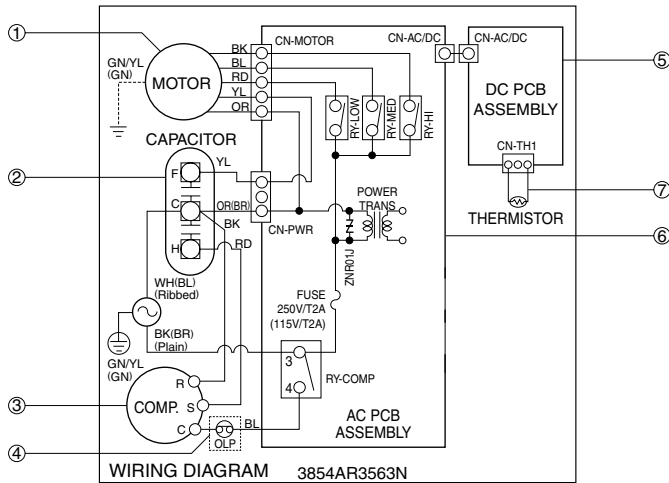

S: Service Parts
N: Non Service Parts

LOCATION NO.	DESCRIPTION	Q'TY PER SET	RE-MARKS
1	MOTOR ASSY	1	S
2	CAPACITOR	1	S
3	COMPRESSOR	1	S
4	OVERLOAD PROTECTOR	1	S
5	DC PCB ASSEMBLY	1	S
6	AC PCB ASSEMBLY	1	S
7	THERMISTOR	1	S
8	THERMOSTAT	1	S
9	ROTARY SWITCH	1	S

6. REPLACEMENT PARTS LIST

R: Service Parts
N: Non Service Parts

• ZQ08B10 • ZQ10B10 • CP08A10 • CP10A10 • CP12A10

ZQ08B10		
Loc No	FRIEDRICH	Description
130410	67302924	BASE ASSEMBLY,SINGLE
130910	67303711	CABINET ASSEMBLY,SINGLE
135312	67306014	GRILLE ASSEMBLY,FRONT(SINGLE)
135313	67306109	GRILLE,INLET
135500	67300311	COVER
147581	67306207	LOUVER,HORIZONTAL
147582-1	67306260	LOUVER,VERTICAL
147582-2	67306261	LOUVER,VERTICAL
148000	67303909	BRACE
149410	67304105	KNOB ASSEMBLY
149980	67303114	SHROUD
152302	67304306	FILTER ASSEMBLY,AIR CLEANER
237200	67305509	PANEL ASSEMBLY,CONTROL
264110	67300017	POWER CORD ASSEMBLY
266003	67300501	SWITCH,ROTARY
269310	67300402	THERMOSTAT ASSEMBLY
346811	67303031	MOTOR ASSEMBLY,SINGLE
349001	67303507	DAMPER,VENTILATION
349480	67303408	ORIFICE
352390-1	67302718	AIR GUIDE ASSEMBLY
352390-2	67302731	AIR GUIDE ASSEMBLY
354210	67302427	EVAPORATOR ASSEMBLY,FIRST
359012	67302611	FAN,TURBO
550140	67301901	ISOLATOR,COMP
552111	67302124	TUBE ASSEMBLY,CAPILLARY
554030	67303324	CONDENSER ASSEMBLY,FIRST
554160	67500121	COMPRESSOR SET,CHINA
559011	67303201	FAN ASSEMBLY,AXIAL
567502	67301417	O.L.P
731373	67306309	INSTALL PART ASSEMBLY,SINGLE
W0CZZ	67300718	CAPACITOR,DRAWING
W48602	67302500	CLAMP,SPRING

ZQ10B10

Loc No	FRIEDRICH	Description
130410	67302913	BASE ASSEMBLY,SINGLE
130910	67303711	CABINET ASSEMBLY,SINGLE
135312	67306014	GRILLE ASSEMBLY,FRONT(SINGLE)
135313	67306109	GRILLE,INLET
135500	67300311	COVER
147581	67306207	LOUVER,HORIZONTAL
147582-1	67306260	LOUVER,VERTICAL
147582-2	67306261	LOUVER,VERTICAL
148000	67303909	BRACE
149410	67304105	KNOB ASSEMBLY
149980	67303110	SHROUD
152302	67304306	FILTER ASSEMBLY,AIR CLEANER
237200	67305509	PANEL ASSEMBLY,CONTROL
249950	67305322	CONTROL BOX ASSEMBLY,SINGLE
264110	67300019	POWER CORD ASSEMBLY
266003	67300501	SWITCH,ROTARY
269310	67300402	THERMOSTAT ASSEMBLY
346811	67303032	MOTOR ASSEMBLY,SINGLE
349001	67303507	DAMPER,VENTILATION
349480	67303408	ORIFICE
352113	67302309	TUBE ASSEMBLY,DISCHARGE SINGLE
352115	67302019	TUBE ASSEMBLY,EVAPORATOR IN
35211A	67302220	TUBE ASSEMBLY,SUCTION SINGLE
352390-1	67302718	AIR GUIDE ASSEMBLY
352390-2	67302731	AIR GUIDE ASSEMBLY
354210	67302428	EVAPORATOR ASSEMBLY,FIRST
359012	67302611	FAN,TURBO
550140	67301901	ISOLATOR,COMP
552111	67302125	TUBE ASSEMBLY,CAPILLARY
554031	67303315	CONDENSER ASSEMBLY,BENT
554160	67500122	COMPRESSOR SET,CHINA
559011	67303201	FAN ASSEMBLY,AXIAL
567502	67301409	O.L.P
731373	67306309	INSTALL PART ASSEMBLY,SINGLE
W0CZZ	67300716	CAPACITOR,DRAWING
W48602	67302500	CLAMP,SPRING

CP08A10

Loc No	FRIEDRICH	Description
130410	67302913	BASE ASSEMBLY,SINGLE
130910	67303711	CABINET ASSEMBLY,SINGLE
135312	67306014	GRILLE ASSEMBLY,FRONT(SINGLE)
135313	67306109	GRILLE,INLET
135500	67300310	COVER
147581	67306207	LOUVER,HORIZONTAL
147582-1	67306260	LOUVER,VERTICAL
147582-2	67306261	LOUVER,VERTICAL
148000	67303909	BRACE
149980	67303110	SHROUD
152302	67304306	FILTER ASSEMBLY,AIR CLEANER
237200	67305508	PANEL,CONTROL
238310	67500116	ESCUTCHEON
263230	67307807	THERMISTOR ASSEMBLY
264110	67300017	POWER CORD ASSEMBLY
267110	67307701	REMOTE CONTROLLER ASSEMBLY
268712	67307614	PWB(PCB) ASSEMBLY,MAIN(DC)
268714	67307613	PWB(PCB) ASSEMBLY,MAIN(AC)
346811	67303018	MOTOR ASSEMBLY,SINGLE
349001	67303507	DAMPER,VENTILATION
349480	67303408	ORIFICE
352390-1	67302718	AIR GUIDE ASSEMBLY
352390-2	67302731	AIR GUIDE ASSEMBLY
354210	67302426	EVAPORATOR ASSEMBLY,FIRST
359012	67302611	FAN,TURBO
550140	67301901	ISOLATOR,COMP
552111	67302123	TUBE ASSEMBLY,CAPILLARY
554031	67303315	CONDENSER ASSEMBLY,BENT
554160	67500120	COMPRESSOR SET,CHINA
559011	67303201	FAN ASSEMBLY,AXIAL
567502	67301406	O.L.P
731373	67306309	INSTALL PART ASSEMBLY,SINGLE
W0CZZ	67300718	CAPACITOR,DRAWING
W48602	67302500	CLAMP,SPRING

CP10A10		
Loc No	FRIEDRICH	Description
130410	67302923	BASE ASSEMBLY,SINGLE
130910	67303710	CABINET ASSEMBLY,SINGLE
135312	67306013	GRILLE ASSEMBLY,FRONT(SINGLE)
135313	67306108	GRILLE,INLET
135500	67300310	COVER
147581	67306206	LOUVER,HORIZONTAL
147582-1	67306258	LOUVER,VERTICAL
147582-2	67306259	LOUVER,VERTICAL
148000	67303908	BRACE
149980	67303113	SHROUD
152302	67304307	FILTER ASSEMBLY,AIR CLEANER
237200	67305508	PANEL,CONTROL
238310	67500116	ESCUTCHEON
263230	67307807	THERMISTOR ASSEMBLY
264110	67300019	POWER CORD ASSEMBLY
267110	67307701	REMOTE CONTROLLER ASSEMBLY
268712	67307613	PWB(PCB) ASSEMBLY,MAIN(AC)
268714	67307614	PWB(PCB) ASSEMBLY,MAIN(DC)
346811	67303030	MOTOR ASSEMBLY,SINGLE
349001	67303506	DAMPER,VENTILATION
349480	67303411	ORIFICE
352390-1	67302729	AIR GUIDE ASSEMBLY
352390-2	67302730	AIR GUIDE
354210	67302425	EVAPORATOR ASSEMBLY,FIRST
359012	67302615	FAN,TURBO
550140	67301901	ISOLATOR,COMP
552111	67302122	TUBE ASSEMBLY,CAPILLARY
554030	67303323	CONDENSER ASSEMBLY,FIRST
554160	67500119	COMPRESSOR SET,CHINA
559011	67302614	FAN,AXIAL
567502	67301409	O.L.P
731373	67306308	INSTALL PART ASSEMBLY,SINGLE
W0CZZ	67300716	CAPACITOR,DRAWING
W48602	67302500	CLAMP,SPRING

CP12A10		
Loc No	FRIEDRICH	Description
130410	67302922	BASE ASSEMBLY,SINGLE
130910	67303710	CABINET ASSEMBLY,SINGLE
135312	67306013	GRILLE ASSEMBLY,FRONT(SINGLE)
135313	67306108	GRILLE,INLET
135500	67300310	COVER
147581	67306206	LOUVER,HORIZONTAL
147582-1	67306258	LOUVER,VERTICAL
147582-2	67306259	LOUVER,VERTICAL
148000	67303908	BRACE
149980	67303112	SHROUD ASSEMBLY
152302	67304307	FILTER ASSEMBLY,AIR CLEANER
237200	67305508	PANEL,CONTROL
238310	67500116	ESCUTCHEON
263230	67307807	THERMISTOR ASSEMBLY
264110	67300018	POWER CORD ASSEMBLY
267110	67307701	REMOTE CONTROLLER ASSEMBLY
268712	67307613	PWB(PCB) ASSEMBLY,MAIN(AC)
268714	67307614	PWB(PCB) ASSEMBLY,MAIN(DC)
346811	67303029	MOTOR ASSEMBLY,SINGLE
349001	67303506	DAMPER,VENTILATION
349480	67303411	ORIFICE
352390-1	67302729	AIR GUIDE ASSEMBLY
352390-2	67302730	AIR GUIDE
354210	67302424	EVAPORATOR ASSEMBLY,FIRST
359011	67302614	FAN,AXIAL
359012	67302615	FAN,TURBO
550140	67301901	ISOLATOR,COMP
552111	67302121	TUBE ASSEMBLY,CAPILLARY
554031	67303322	CONDENSER ASSEMBLY,BENT
554160	67500118	COMPRESSOR SET,CHINA
567502	67301416	O.L.P
731373	67306308	INSTALL PART ASSEMBLY,SINGLE
W0CZZ	67300716	CAPACITOR,DRAWING

MEMO

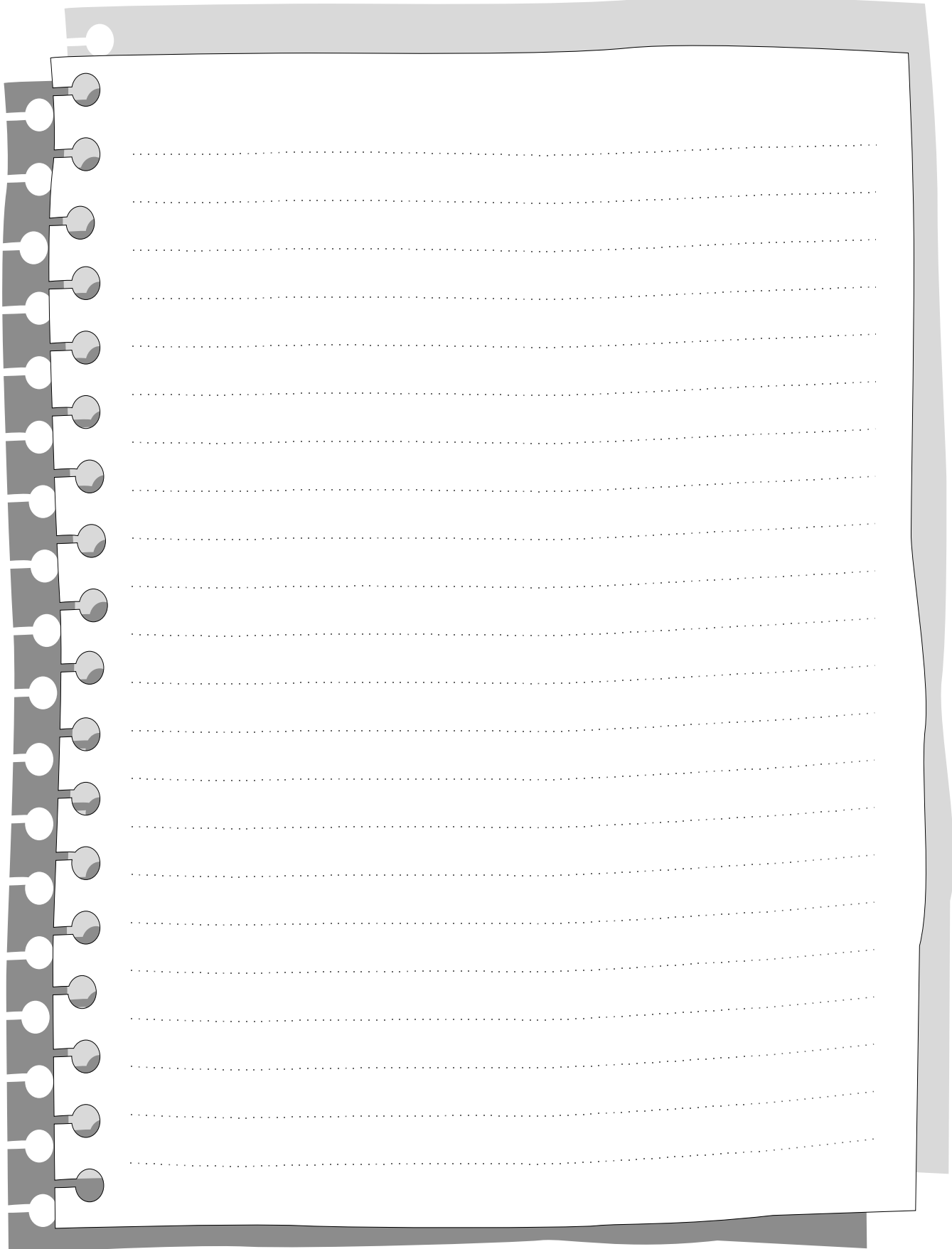

MEMO

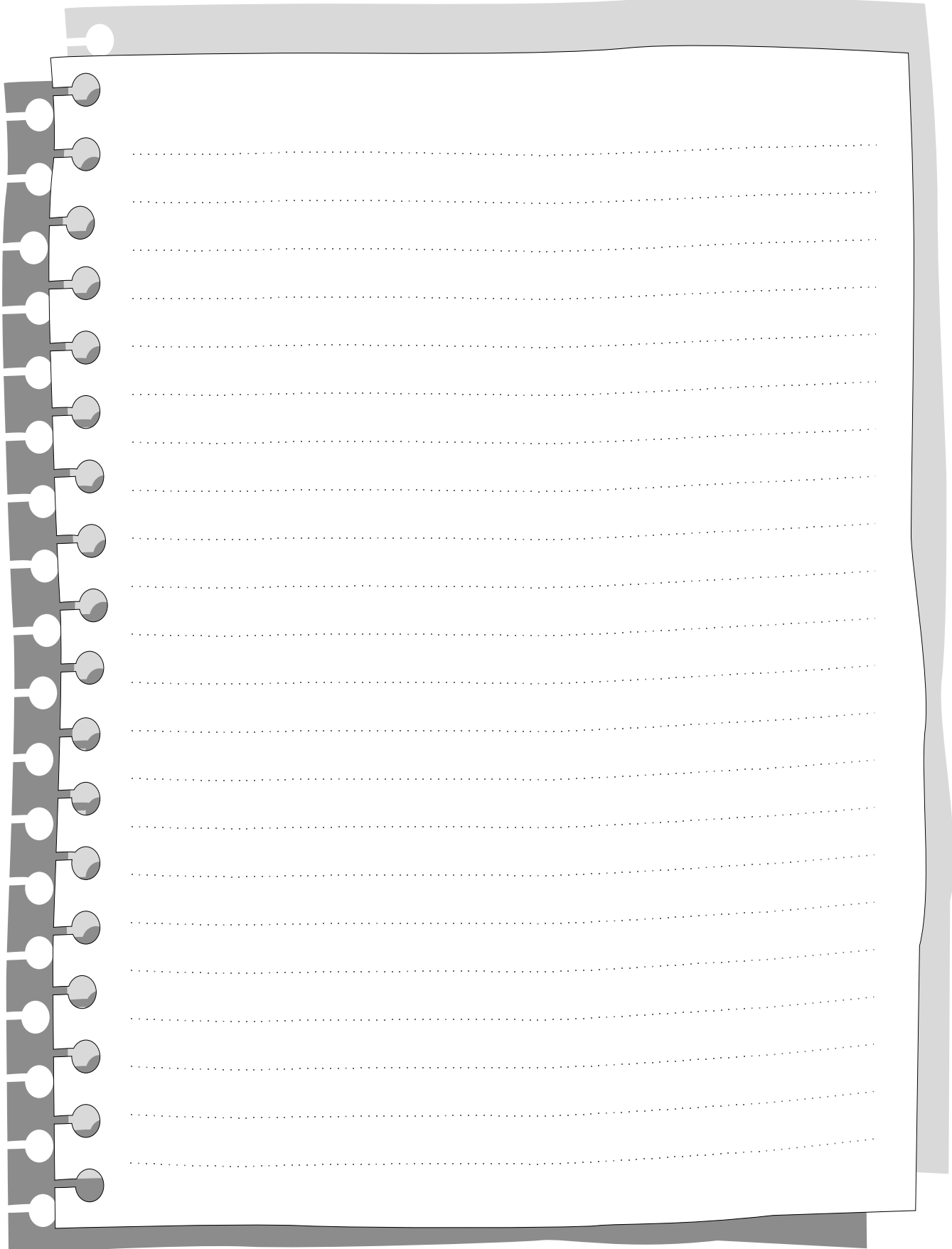

Use Factory Certified Parts...

Friedrich[®]

FRIEDRICH AIR CONDITIONING CO.

Visit our web site at www.friedrich.com

Post Office Box 1540 • 4200 N. Pan Am Expressway • San Antonio, Texas 78295-1540
• (210) 357-4400 • FAX (210) 357-4490

Free Manuals Download Website

<http://myh66.com>

<http://usermanuals.us>

<http://www.somanuals.com>

<http://www.4manuals.cc>

<http://www.manual-lib.com>

<http://www.404manual.com>

<http://www.luxmanual.com>

<http://aubethermostatmanual.com>

Golf course search by state

<http://golfingnear.com>

Email search by domain

<http://emailbydomain.com>

Auto manuals search

<http://auto.somanuals.com>

TV manuals search

<http://tv.somanuals.com>