

Friedrich®

1998 QuietMaster® J Series

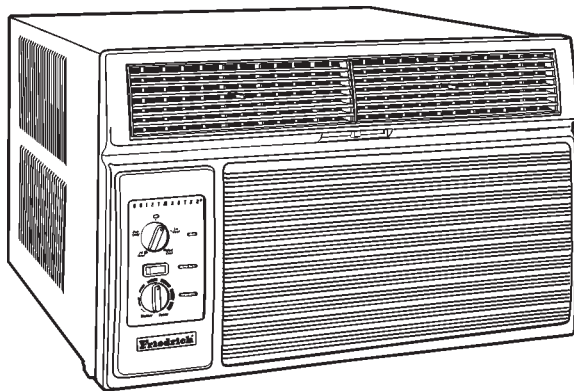

**KS10J10
KS12J10
KS12J30A
KM18J30A
KM21J30
KL25J30**

Service & Parts Manual

AMERICA'S BEST AIR CONDITIONER

TABLE OF CONTENTS

PAGE

GENERAL

Friedrich Room Model Number Code	3
Application and Sizing	4
Instructions for using Cooling Load Estimate Form	5
Cooling Load Estimate Form	6

SPECIFICATIONS/PERFORMANCE DATA

Specifications "KS" - "KM" - "KL" Models	7
Performance Data "KS" - "KM" - "KL" Models	7

COMPONENTS OPERATION/TESTING

Compressors	8
Thermal Overload (External)	8
Thermal Overload (Internal)	9
Fan Motor	9
Run Capacitor	10
System Control Switch ("KS", "KM", & "KL" Models)	10
Thermostat ("KS", "KM", & "KL" Models)	11
Thermostat Adjustment	11
Resistor	12
MoneySaver Switch (Rocker Switch)	12
Sealed Refrigeration System Repairs	12
Hermetic Component Replacement	13
Special Procedure in the case of Motor Compressor Burn-Out	13
Rotary Compressor Special Troubleshooting & Service	14
Refrigerant Charge	14

TROUBLESHOOTING

Troubleshooting Cooling	15
-------------------------------	----

WIRING DIAGRAMS

KS10J10	618-200-00	19
KS12J10	618-200-00	19
KS12J30A	618-200-00	19
KM18J30A	618-200-00	19
KM21J30	618-200-00	19
KL25J30A	618-200-00	19

PARTS LIST

"KS" - "KM" Series Chassis Parts	20
"KS" - "KM" Series Cabinet Parts	21
"KS" - "KM" Series Parts List	20
"KL" Series Chassis Parts	25
"KL" Series Cabinet Parts	26
"KL" Series Parts List	25

FRIEDRICH ROOM MODEL NUMBER CODE

K S 10 G 1 0 D

1st DIGIT - FUNCTION

- S = Straight Cool, Value Series
- C = Straight Cool, Budget Series
- Y = Heat Pump
- E = Electric Strip
- K = Straight Cool, Challenger or QuietMaster Series
- W = Thru-The-Wall, WallMaster Series

2nd DIGIT - TYPE

- C = Casement
- P = PowerMiser "Portable"
- Q = QStar, KStar or YQ TwinTemp
- S = Small Chassis
- M = Medium Chassis
- L = Large Chassis
- W = Built-In
- H = Hazardgard

3rd & 4th DIGITS - APPROXIMATE BTU/HR (Cooling)

Heating BTU/HR capacity listed in Specifications/Performance Data Section

5th DIGIT - ALPHABETICAL MODIFIER

6th DIGIT - VOLTAGE

- 1 = 115 Volts
- 2 = 230 Volts
- 3 = 230-208 Volts

7th DIGIT

- 0 = Straight Cool & Heat Pump Models
- ELECTRIC HEAT MODELS**
- 1 = 1 KW Heat Strip, Nominal
- 3 = 3 KW Heat Strip, Nominal
- 4 = 4 KW Heat Strip, Nominal
- 5 = 5 KW Heat Strip, Nominal
- 8 = 8 KW Heat Strip, Nominal

8th DIGIT

Major Change

APPLICATION AND SIZING

In the application and sizing of room air conditioners for cooling, it is most important to give full consideration to all factors which may contribute to the heat loss or gain of the space to be conditioned. It is therefore necessary to make a survey of the space to be conditioned and calculate the load requirements before a selection of the size of the equipment needed can be made.

The load requirement may be determined very easily by simply using the standard "AHAM" Load Calculating Form, on Page 6. This form is very easy to use and is self explanatory throughout. It is necessary only to insert the proper measurements on the lines provided and multiply by the given factors, then add the result for the total load requirements.

Cooling load requirements are generally based on the cooling load for comfortable air conditioning which does not require specific conditions of inside temperature and humidity. The load calculation form is based on outside design temperature of 95° FDB and 75° FWB. It can be used for areas in the Continental United States having other outside design temperatures by applying a correction factor for the particular locality as determined from the map shown on Page 6.

When sizing a TwinTemp unit for cooling and heating, we must remember that the heating capacity of any given unit varies directly with the outdoor ambient temperature. Also, we must keep in mind the average low temperatures which might be experienced in the locality where the unit is to be installed. Therefore, when sizing a TwinTemp unit, both cooling and heating requirements must be calculated. Do not oversize, or undersize, one phase of the unit's capacity at the expense of the other. In those cases where the unit will provide satisfactory cooling at all times but will be inadequate for those few times that the outdoor temperature is below the maximum low for the unit, additional auxiliary heating facilities must be provided to insure that adequate heat is available at all times.

**INSTRUCTIONS FOR USING COOLING LOAD ESTIMATE
FORM FOR ROOM AIR CONDITIONERS
(AHAM PUB. NO. RAC-1)**

- A. This cooling load estimate form is suitable for estimating the cooling load for comfort air conditioning installations which do not require specific conditions of inside temperature and humidity.
- B. The form is based on an outside design temperature of 95°F dry bulb and 75°F wet bulb. It can be used for areas in the continental United States having other outside design temperatures by applying a correction factor for the particular locality as determined from the map.
- C. The form includes "day" factors for calculating cooling loads in rooms where daytime comfort is desired (such as living rooms, offices, etc.)
- D. The numbers of the following paragraphs refer to the corresponding numbered item on the form:
1. Multiply the square feet of window area for each exposure by the applicable factor. The window area is the area of the wall opening in which the window is installed. For windows shaded by inside shades or venetian blinds, use the factor for "Inside Shades." For windows shaded by outside awnings or by both outside awnings and inside shades (or venetian blinds), use the factor for "Outside Awnings." "Single Glass" includes all types of single thickness windows, and "Double Glass" includes sealed airspace types, storm windows, and glass block. Only one number should be entered in the right hand column for Item 1, and this number should represent **only the exposure with the largest load.**
 2. Multiply the total square feet of **all** windows in the room by the applicable factor.
 - 3a. Multiply the total length (linear feet) of all walls exposed to the outside by the applicable factor. Doors should be considered as being part of the wall. Outside walls facing due north should be calculated separately from outside walls facing other directions. Walls which are permanently shaded by adjacent structures should be considered "North Exposure." Do not consider trees and shrubbery as providing permanent shading. An uninsulated frame wall or a masonry wall 8 inches or less in thickness is considered "Light Construction." An insulated wall or masonry wall over 8 inches in thickness is considered "Heavy Construction."
 - 3b. Multiply the total length (linear feet) of all inside walls between the space to be conditioned and any unconditioned spaces by the given factor. Do not include inside walls which separate other air conditioned rooms.
 4. Multiply the total square feet of roof or ceiling area by the factor given for the type of construction most nearly describing the particular application (use one line only.)
 5. Multiply the total square feet of floor area by the factor given. Disregard this item if the floor is directly on the ground or over a basement.
 6. Multiply the number of people who normally occupy the space to be air conditioned by the factor given. Use a minimum of 2 people.
 7. Determine the total number of watts for light and electrical equipment, except the air conditioner itself, that will be **in use** when the room air conditioning is operating. Multiply the total wattage by the factor given.
 8. Multiply the total width (linear feet) of any doors or arches which are continually open to an unconditioned space by the applicable factor.
NOTE: Where the width of the doors or arches is more than 5 feet, the actual load may exceed the calculated value. In such cases, both adjoining rooms should be considered as a single large room, and the room air conditioner unit or units should be selected according to a calculation made on this new basis.
 9. Total the loads estimated for the foregoing 8 items.
 10. Multiply the subtotal obtained in item 9 by the proper correction factor, selected from the map, for the particular locality. The result is the total estimated design cooling load in BTU per hour.
- E. For best results, a room air conditioner unit or units having a cooling capacity rating (determined in accordance with the NEMA Standards Publication for Room Air Conditioners, CN 1-1960) as close as possible to the estimated load should be selected. In general, a greatly oversized unit which would operate intermittently will be much less satisfactory than one which is slightly undersized and which would operate more nearly continuously.
- F. Intermittent loads such as kitchen and laundry equipment are not included in this form.

SPECIFICATIONS	KS10J10	KS12J10	KS12J30A	KM18J30A	KM21J30	KL25J30A
BTUH	10000	12000	12500 12500	18000 18000	21000 20500	25000 24700
E.E.R.	10.3	9.5	10.0 10.0	9.6 9.6	9.0 9.0	8.3 8.2
Volts	115	115	230 208	230 208	230 208	230 208
Amperes	9.1	10.8	5.8 6.2	8.3 9.1	10.5 11.3	13.5 15.0
Total Watts	970	1265	1250 1250	1875 1875	2335 2280	3010 3010
Hertz	60	60	60	60	60	60
Fuse/Breaker Size	15	15	15	15	15	20
Fan RPM	1115	1080	1180	1120	1120	1120
Evaporator Air CFM	325	325	325	440	535	610
Fresh Air CFM	Yes	Yes	Yes	Yes	Yes	Yes
Exhaust Air CFM	Yes	Yes	Yes	Yes	Yes	Yes
Dehumidification Pts/HR	2.8	3.5	3.5	5.5	6.3	7.6
Width	25-15/16"	25-15/16"	25-15/16"	25-15/16"	25-15/16"	28"
Height	15-15/16"	15-15/16"	15-15/16"	17-15/16"	17-15/16"	20-3/16"
Depth	27-3/8"	27-3/8"	27-3/8"	27-3/8"	27-3/8"	33-5/8"
Minimum Ext. Into Room	3-1/16"	3-1/16"	3-1/16"	3-1/16"	3-3/16"	3-3/16"
Minimum Ext. to Outside	16-15/16"	16-15/16"	16-15/16"	16-15/16"	16-15/16"	18-15/16"
Net Weight	108	111	111	136	183	190
Shipping Weight	118	121	121	148	203	210

PERFORMANCE DATA* Cooling	EVAPORATOR AIR TEMP. °F.		OPERATING PRESSURES		ELECTRICAL RATINGS		R-22 REFRIG.	COMP. OIL
	DISCHARGE AIR	TEMP. DROP °F	SUCTION	DISCHARGE	AMPS	LOCKED ROTOR AMPS	CHARGE IN OZ.	CHARGE IN FLUID OZ.
KS10J10	61.0	19.0	79.0	269	9.1	48.3	21.0	11.8
KS12J10	57.0	23.0	78.0	288	10.8	54.0	25.0	11.8
KS12J30A	57.0	23.0	79.0	293	5.8 6.2	26.3	26.0	11.8
KM18J30A	56.0	24.0	73.0	262	8.3 9.1	42.0	46.0	13.9
KM21J30	56.0	24.0	75.0	260	10.5 11.3	56.0	46.0	32.0
KL25J30A	55.0	25.0	68.5	300	13.5 15.0	71.0	34.0	32.0

* Rating Conditions: 80°F. Room Air Temperature and 50% Relative Humidity with
95°F. Outside Air Temperature at 40% Relative Humidity.

COMPONENTS OPERATION & TESTING

WARNING

DISCONNECT ELECTRICAL POWER TO UNIT BEFORE SERVICING OR TESTING

COMPRESSORS

Compressors are single phase, 15 or 230/208 volt, depending on the model unit. All compressor motors are permanent split capacitor type using only a running capacitor across the start and run terminal.

All compressors are internally spring mounted and externally mounted on rubber isolators.

COMPRESSOR WINDING TEST (See Figure 1)

Remove compressor terminal box cover and disconnect wires from terminals. Using an ohmmeter, check continuity across the following:

1. Terminal "C" and "S" - no continuity - open winding - replace compressor.
2. Terminal "C" and "R" - no continuity - open winding - replace compressor.
3. Terminal "R" and "S" - no continuity - open winding - replace compressor.

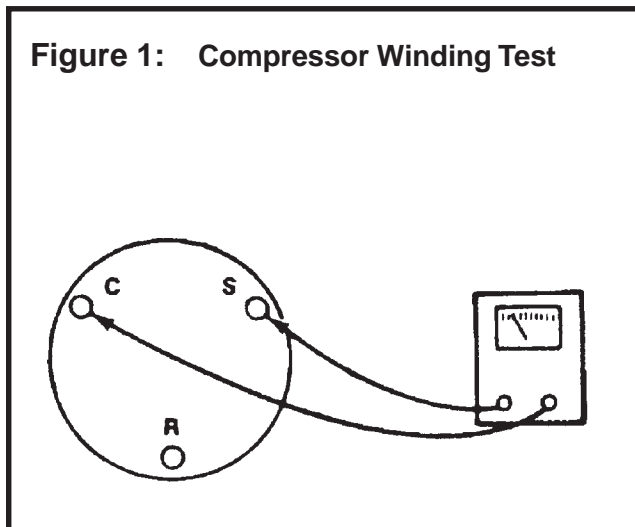

Figure 1: Compressor Winding Test

GROUND TEST

Use an ohmmeter set on its highest scale. Touch one lead to the compressor body (clean point of contact as a good connection is a must) and the other probe in turn to each compressor terminal (see Figure 2.) If a reading is obtained, the compressor is grounded and must be replaced.

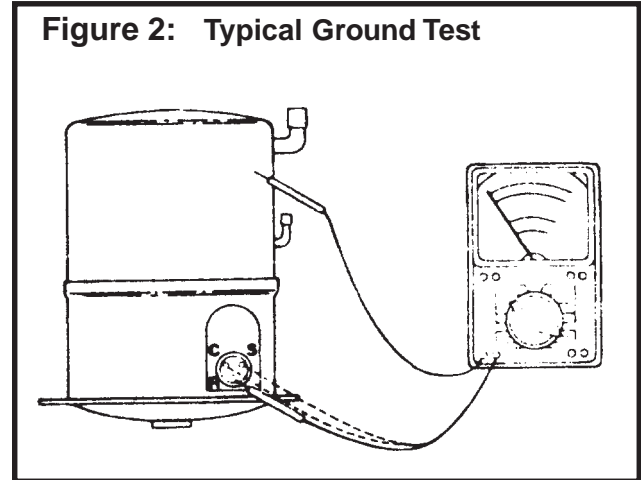

Figure 2: Typical Ground Test

CHECKING COMPRESSOR EFFICIENCY

The reason for compressor inefficiency is normally due to broken or damaged suction and/or discharge valves, reducing the ability of the compressor to pump refrigerant gas.

This condition can be checked as follows:

1. Install a piercing valve on the suction and discharge or liquid process tube.
2. Attach gauges to the high and low sides of the system.
3. Start the system and run a "cooling or heating performance test."

If test shows:

- A. **Below** normal high side pressure.
- B. **Above** normal low side pressure.
- C. **Low** temperature difference across coil.

The compressor valves are faulty - replace the compressor.

THERMAL OVERLOAD (External)

Some compressors are equipped with an external overload which is located in the compressor terminal box adjacent to the compressor body (see Figure 3.)

The overload is wired in series with the common motor terminal. The overload senses both major amperage and compressor temperature. High motor temperature or amperage heats the disc causing it to open and break the circuit to the common motor terminal.

Figure 3: External Overload

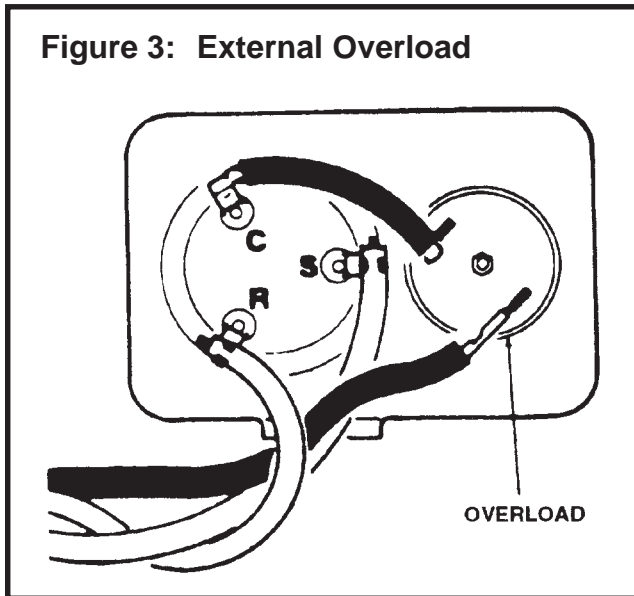

Heat generated within the compressor shell is usually due to:

1. High amperage.
2. Low refrigerant charge.
3. Frequent recycling.
4. Dirty condenser.

THERMAL OVERLOAD - TEST
(Compressor - External Type)

1. Remove overload.
2. Allow time for overload to reset before attempting to test.
3. Apply ohmmeter probes to terminals on overload wires. There should be continuity through the overload.

TERMINAL OVERLOAD (Internal)

Some model compressors are equipped with an internal overload. The overload is embedded in the motor windings to sense the winding temperature and/or current draw. The overload is connected in series with the common motor terminal.

Should the internal temperature and/or current draw become excessive, the contacts in the overload will open, turning off the compressor. The overload will automatically reset, but may require several hours before the heat is dissipated.

CHECKING THE INTERNAL OVERLOAD
(see Figure 4.)

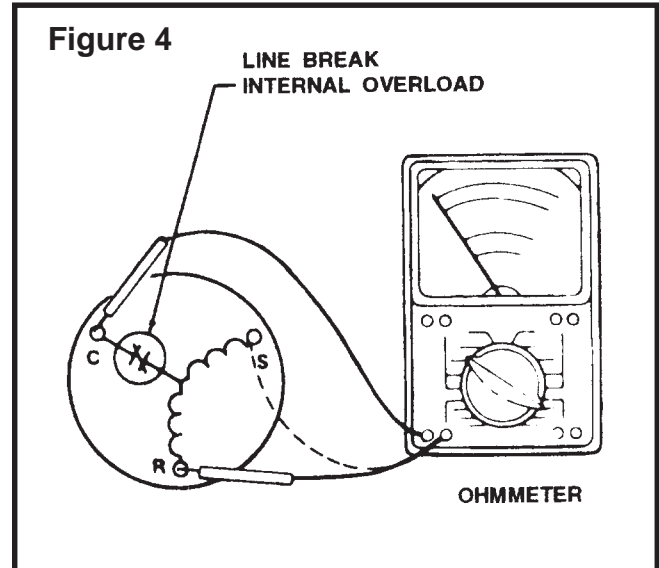

1. With no power to unit, remove the leads from the compressor terminals.
2. Using an ohmmeter, test continuity between terminals C-S and C-R. If not continuous, the compressor overload is open and the compressor must be replaced.

FAN MOTOR

A single phase permanent split capacitor motor is used to drive the evaporator blower and condenser fan. A self-resetting overload is located inside the motor to protect against high temperature and high amperage conditions.

FAN MOTOR - TEST

1. Determine that capacitor is serviceable.
2. Disconnect fan motor wires from fan speed switch or system switch.
3. Apply "live" test cord probes on black wire and common terminal of capacitor. Motor should run at high speed.
4. Apply "live" test cord probes on red wire and common terminal of capacitor. Motor should run at low speed.

Figure 5: Fan Motor

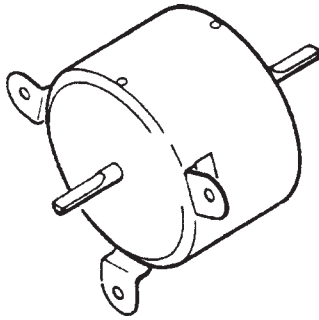

5. Apply "live" test cord probes on each of the remaining wires from the speed switch or system switch to test intermediate speeds.

CAPACITOR, RUN

A run capacitor is wired across the auxiliary and main winding of a single phase permanent split capacitor motor such as the compressor and fan motor. A single capacitor can be used for each motor or a dual rated capacitor can be used for both.

The capacitor's primary function is to reduce the line current while greatly improving the torque characteristics of a motor. The capacitor also reduces the line current to the motor by improving the power factor of the load. The line side of the capacitor is marked with a red dot and is wired to the line side of the circuit (see Figure 6.)

Figure 6: Run Capacitor Hook-Up

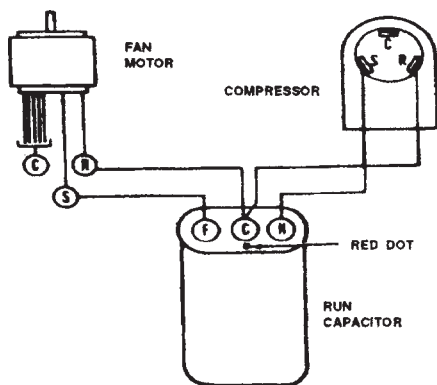

CAPACITOR - TEST

1. Remove capacitor from unit.
2. Check for visual damage such as bulges, cracks, or leaks.
3. For dual rated, apply an ohmmeter lead to common (C) terminal and the other probe to the compressor (HERM) terminal. A satisfactory capacitor will cause a deflection on the pointer, then gradually move back to infinity.
4. Reverse the leads of the probe and momentarily touch the capacitor terminals. The deflection of the pointer should be two times that of the first check if the capacitor is good.
5. Repeat steps 3 and 4 to check fan motor capacitor.

NOTE: A shorted capacitor will indicate a low resistance and the pointer will move to the "0" end of the scale and remain there as long as the probes are connected.

An open capacitor will show no movement of the pointer when placed across the terminals of the capacitor.

SYSTEM CONTROL SWITCH

A five position control switch is used to regulate the operation of the fan motor and compressor. The compressor can be operated with the fan operating at low, medium or high speed. The fan motor can also be operated independently on medium speed. See switch section as indicated on decorative control panel (see Figure 7.)

SYSTEM CONTROL SWITCH - TEST

Disconnect leads from control switch (see Figure 8.) There must be continuity as follows:

1. "Off" Position - no continuity between terminals.
2. "Lo Cool" Position - between terminals "L1" and "C", "LO" and "MS".
3. "Med Cool" Position - between terminals "L1" and "C", "M" and "MS".
4. "Hi Cool" Position - between terminals "L1" and "C", "H" and "MS".
5. "Fan Only" Position - between terminals "L1" and "2".

Figure 7: System Control Panel

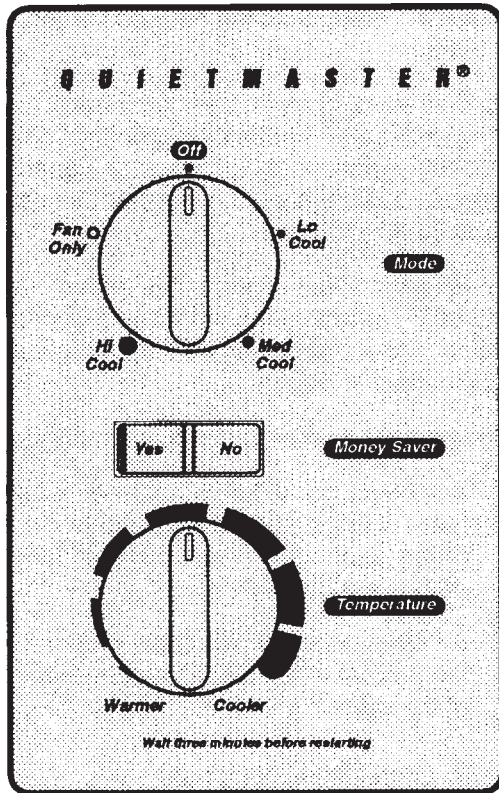

to supply a small amount of heat to the bulb area to prevent long "off cycles" in the "Cool-Fan Auto" (Money-Saver) position (see Figure 10.) A current feedback through the fan motor windings during "off cycle" completes the circuit to the resistor.

RANGE: Cooling Model Thermostat
(Part No. 618-225-00)

60°F (± 2°) to 92°F (± 4°),

TEST:

Remove wires from thermostat. Turn the thermostat to its coldest position. Check to see if there is continuity between the two terminals. Turn the thermostat to its warmest position. Check continuity to see if thermostat contacts open. NOTE: Temperature must be within range listed to check thermostat. Refer to the troubleshooting section in this manual for additional information on thermostat testing.

Figure 8: System Control Switch

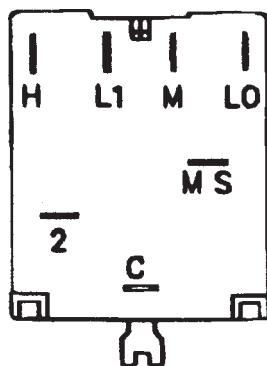
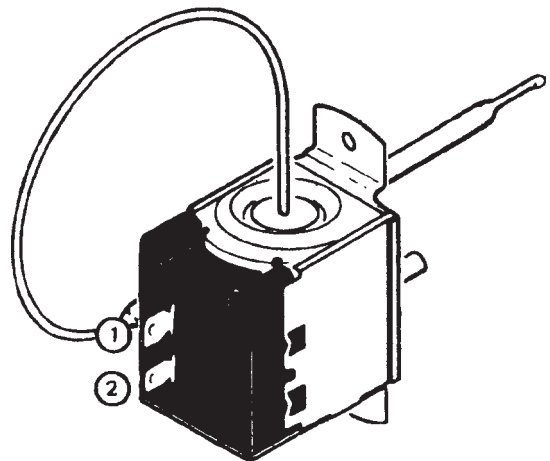

Figure 9: Thermostat



THERMOSTAT (Figure 9)

A cross ambient thermostat is used on all standard chassis units. In addition to cycling the unit in a heating or cooling operation, the thermostat will terminate the cooling cycle in the event ice forms on the evaporator coil, in this case the thermostat functions as a de-ice control. A resistor (anticipator) is positioned within a plastic block

THERMOSTAT ADJUSTMENT

No attempt should be made to adjust thermostat. Due to the sensitivity of the internal mechanism and the sophisticated equipment required to check the calibration, it is suggested that the thermostat be replaced rather than calibrated.

RESISTOR (Heat Anticipator)

Failure of the resistor will cause prolonged "off" and "on" cycles of the unit. When replacing a resistor, be sure and use the exact replacement. Resistor ratings are as follows:

115 Volt - 5,000 ohms 3 watt
230 Volt - 20,000 ohms 3 watt

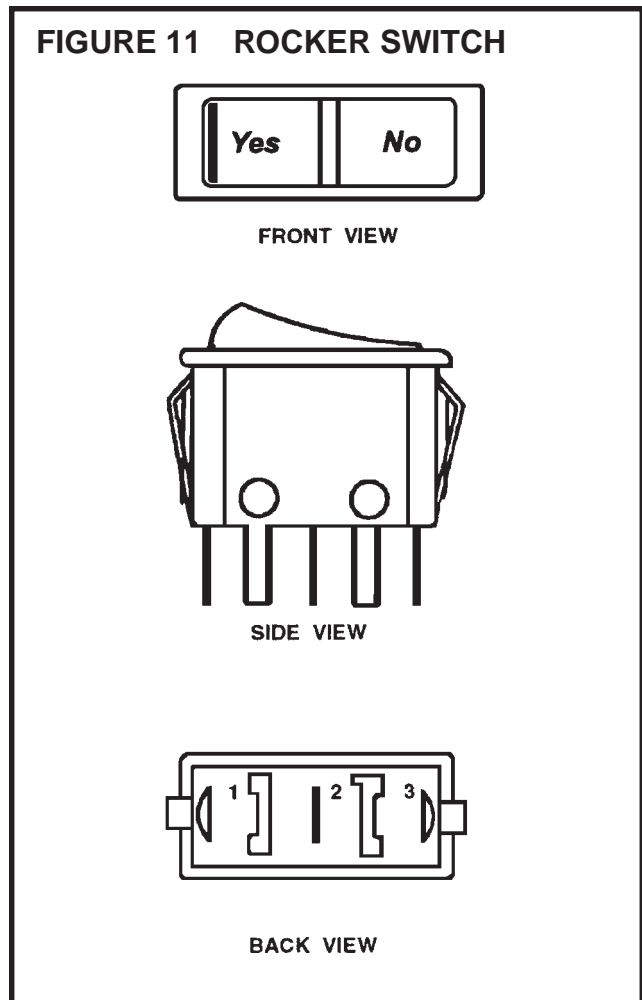
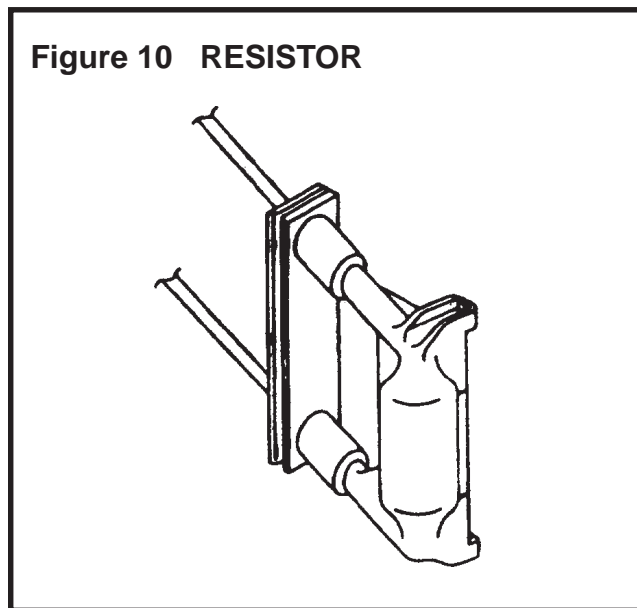

MONEYSAVER® SWITCH (Rocker Switch) - (See Figure 11)

This rocker switch can be depressed to either **YES** or **NO**. In the **YES** position you will get the most economical operation. Both the fan and compressor will cycle on and off together, maintaining the selected temperature at a more constant level and reducing the humidity more efficiently. This control will only operate when the unit is in a cooling mode. In the **NO** position, the fan will run constantly as long as the unit is in the cooling mode.

TEST:

Disconnect leads from switch. Depress switch to function being tested.

1. When **YES** is depressed, there should be continuity between terminals "1" and "2".
2. When **NO** is depressed, there should be continuity between terminals "2" and "3".

SEALED REFRIGERATION SYSTEM REPAIRS

EQUIPMENT REQUIRED

1. Voltmeter
2. Ammeter
3. Ohmmeter
4. E.P.A. Approved Refrigerant Recovery System.
5. Vacuum Pump (capable of 200 microns or less vacuum.)
6. Acetylene Welder
7. Electronic Halogen Leak Detector (G.E. Type H-6 or equivalent.)
8. Accurate refrigerant charge measuring device such as:

- a. Balance Scales - 1/2 oz. accuracy
- b. Charging Board - 1/2 oz. accuracy
- 9. High Pressure Gauge - (0 - 400 lbs.)
- 10. Low Pressure Gauge - (30 - 150 lbs.)
- 11. Vacuum Gauge - (0 - 1000 microns)

EQUIPMENT MUST BE CAPABLE OF:

- 1. Recovering CFCs as low as 5%.
- 2. Evacuation from both the high side and low side of the system simultaneously.
- 3. Introducing refrigerant charge into high side of the system.
- 4. Accurately weighing the refrigerant charge actually introduced into the system.
- 5. Facilities for flowing nitrogen through refrigeration tubing during all brazing processes.

HERMETIC COMPONENT REPLACEMENT

The following procedure applies when replacing components in the sealed refrigeration circuit or repairing refrigerant leaks. (Compressor, condenser, evaporator, capillary tube, refrigerant leaks, etc.)

- 1. Recover the refrigerant from the system at the process tube located on the high side of the system by installing a line tap on the process tube. Apply gauge from process tube to EPA approved gauges from process tube to EPA approved recovery system. Recover CFCs in system to at least 5%.
- 2. Cut the process tube below pinch off on the suction side of the compressor.
- 3. Connect the line from the nitrogen tank to the suction process tube.
- 4. Drift dry nitrogen through the system and unsolder the more distant connection first. (Filter drier, high side process tube, etc.)
- 5. Replace inoperative component, and always install a new filter drier. Drift dry nitrogen through the system when making these connections.
- 6. Pressurize system to 30 PSIG with proper refrigerant and boost refrigerant pressure to 150 PSIG with dry nitrogen.

- 7. Leak test complete system with electric halogen leak detector, correcting any leaks found.
- 8. Reduce the system to zero gauge pressure.
- 9. Connect vacuum pump to high side and low side of system with deep vacuum hoses, or copper tubing. (Do not use regular hoses.)
- 10. Evacuate system to maximum absolute holding pressure of 200 microns or less. NOTE: This process can be speeded up by use of heat lamps, or by breaking the vacuum with refrigerant or dry nitrogen at 5,000 microns. Pressure system to 5 PSIG and leave in system a minimum of 10 minutes. Recover refrigerant, and proceed with evacuation of a pressure of 200 microns or a minimum of 10 %.
- 11. Break vacuum by charging system from the high side with the correct amount of refrigerant specified. This will prevent boiling the oil out of the crankcase.

NOTE: If the entire charge will not enter the high side, allow the remainder to enter the low side in small increments while operating the unit.

- 12. Restart unit several times after allowing pressures to stabilize. Pinch off process tubes, cut and solder the ends. Remove pinch off tool, and leak check the process tube ends.

SPECIAL PROCEDURE IN THE CASE OF MOTOR COMPRESSOR BURNOUT

- 1. Recover all refrigerant and oil from the system.
- 2. Remove compressor, capillary tube and filter drier from the system.
- 3. Flush evaporator condenser and all connecting tubing with dry nitrogen or equivalent, to remove all contamination from system. Inspect suction and discharge line for carbon deposits. Remove and clean if necessary.
- 4. Reassemble the system, including new drier strainer and capillary tube.
- 5. Proceed with processing as outlined under hermetic component replacement.

ROTARY COMPRESSOR SPECIAL TROUBLESHOOTING AND SERVICE

Basically, troubleshooting and servicing rotary compressors is the same as on the reciprocating compressor with only a few exceptions.

1. Because of the spinning motion of the rotary, the mounts are critical. If vibration is present, check the mounts carefully.
2. The electrical terminals on the rotary are in a different order than the reciprocating compressors. The terminal markings are on the cover gasket. Use your wiring diagram to insure correct connections.

REFRIGERANT CHARGE

1. The refrigerant charge is extremely critical. Measure charge carefully - as exact as possible to the nameplate charge.
2. The correct method for charging the rotary is to introduce liquid refrigerant into the high side of the system with the unit off. Then start compressor and enter the balance of the charge, gas only, into the low side.

The introduction of liquid into the low side, without the use of a capillary tube, will cause damage to the discharge valve of the rotary compressor.

NOTE: All inoperative compressors returned to Friedrich must have all lines properly plugged with the plugs from the replacement compressor.

Troubleshooting Cooling

PROBLEM	POSSIBLE CAUSE	TO CORRECT
Compressor does not run.	Low voltage.	Check for voltage at compressor. 115 volt and 230 volt units will operate at 10% voltage variance.
	Thermostat not set cold enough or inoperative.	Set thermostat to coldest position. Test thermostat and replace if inoperative.
	Compressor hums but cuts off on overload.	Hard start compressor. Direct test compressor. If compressor starts, add starting components.
	Open or shorted compressor windings.	Check for continuity and resistance.
	Open overload.	Test overload protector and replace if inoperative.
	Open capacitor.	Test capacitor and replace if inoperative.
	Inoperative system switch.	Test for continuity in all positions. Replace if inoperative.
	Broken, loose or incorrect wiring.	Refer to appropriate wiring diagram to check wiring.

PROBLEM	POSSIBLE CAUSE	TO CORRECT
Fan motor does not run.	Inoperative system switch.	Test switch and replace if inoperative.
	Broken, loose or incorrect wiring.	Refer to applicable wiring diagram.
	Open capacitor.	Test capacitor and replace if inoperative.
	Fan speed switch open.	Test switch and replace if inoperative.
	Inoperative fan motor.	Test fan motor and replace if inoperative (be sure internal overload has had time to reset).

PROBLEM	POSSIBLE CAUSE	TO CORRECT
Does not cool, or cools only slightly.	Undersized unit.	Refer to Sizing Charts.
	Thermostat open or inoperative.	Set to coldest position. Test thermostat and replace if necessary.
	Dirty filter	Clean as recommended in the Owner's Manual.
	Dirty or plugged condenser or evaporator coil.	Use steam or detergents to clean.
	Pool air circulation in area being cooled.	Adjust discharge air louvers. Use high fan speed.
	Fresh air or exhaust air door open on applicable models.	Close doors. Instruct customer on use of this feature.
	Low capacity - undercharge.	Clean for leak and make repair.
	Compressor not pumping properly.	Check amperage draw against nameplate. If not conclusive, make pressure test.

PROBLEM	POSSIBLE CAUSE	TO CORRECT
Unit does not run.	Fuse blown or circuit tripped.	Replace fuse, reset breaker. If repeats, check fuse or breaker size. Check for shorts in unit wiring and components
	Power cord not plugged in.	Plug in power cord
	System switch in "Off" position.	Set switch correctly.
	Inoperative system switch.	Test for continuity in each switch position.
	Loose or disconnected wiring at switch or other components	Check wiring and connections. Reconnect per wiring diagram.

PROBLEM	POSSIBLE CAUSE	TO CORRECT
Evaporator coil freezes up.	Dirty filter.	Clean as recommended in Owner's Manual.
	Restricted air flow.	Check for dirty or obstructed coil - clean as required.
	Inoperative thermostat.	Test for shorted thermostat or stuck contacts.
	Short of refrigerant.	De-ice coil and check for leak.
	Inoperative fan motor.	Test fan motor and replace if inoperative.
	Partially restricted capillary.	De-ice coil. Check temperature differential across coil. Touch test coil return bends for same temperature. Test for low running current.

PROBLEM	POSSIBLE CAUSE	TO CORRECT
Compressor runs continually. Does not cycle off.	Excessive heat load.	Unit undersized. Test cooling performance of unit. Replace with larger unit.
	Restriction in line.	Check for partially iced coil. Check temperature split across coil.
	Refrigerant leak.	Check for oil at silver soldered connections. Check for partially iced coil. Check split across coil. Check for low running amperage.
	Thermostat contacts stuck.	Check operation of thermostat. Replace if contacts remain closed.
	Thermostat incorrectly wired.	Refer to appropriate wiring diagram.

PROBLEM	POSSIBLE CAUSE	TO CORRECT
Thermostat does not turn unit off.	Thermostat contacts stuck.	Replace thermostat.
	Thermostat set at coldest point.	Turn to higher temperature setting to see if unit cycles off.
	Incorrect wiring.	Refer to appropriate wiring diagram.
	Unit undersized for area to be cooled.	Refer to Sizing Chart.

PROBLEM	POSSIBLE CAUSE	TO CORRECT
Compressor attempts to start, or runs for short periods only. Cycles on overload.	Overload inoperative. Opens too soon.	Check operation of unit. Replace overload if system operation is satisfactory.
	Compressor attempts to start before system pressures are equalized.	Allow a minimum of two (2) minutes for pressures to equalize before attempting to restart. Instruct customer of waiting period.
	Low or fluctuating voltage.	Check voltage with unit operating. Check for other appliances on the circuit. The air conditioner should be on a separate circuit for proper voltage, and be fused separately.
	Incorrect wiring.	Refer to appropriate wiring diagram.
	Shorted or incorrect capacitor.	Check by substituting a known good capacitor of correct rating.
	Restricted or low air flow through condenser coil.	Check for proper fan speed or blocked condenser.
	Compressor running abnormally hot.	Check for kinked discharge line or restricted condenser. Check amperage.

PROBLEM	POSSIBLE CAUSE	TO CORRECT
Thermostat does not turn unit on.	Loss of charge in thermostat bulb.	Place jumper across thermostat terminals to check if unit operates. If unit operates, replace the thermostat.
	Loose or broken parts in thermostat.	Check as above.
	Incorrect wiring.	Refer to appropriate wiring diagram.

PROBLEM	POSSIBLE CAUSE	TO CORRECT
Noisy operation.	Poorly installed unit.	Refer to Installation Instructions for proper installation.
	Fan blade striking chassis.	Reposition - adjust motor mount.
	Compressor vibrating.	Check that compressor grommets have not deteriorated.
	Improperly mounted or loose cabinet parts.	Check that compressor mounting parts are not missing.

PROBLEM	POSSIBLE CAUSE	TO CORRECT
Water leaks into room.	Evaporator drain pan overflowing.	Clean obstructed drain trough.
	Condensation forming on base pan.	Evaporator drain pan broken or cracked. Reseal or replace.
	Poor installation resulting in rain entering room.	Check installation instructions. Reseal as required.
	Condensation on discharge grilles.	Dirty evaporator coil - clean. Very high humidity level.

PROBLEM	POSSIBLE CAUSE	TO CORRECT
Thermostat short cycles.	Thermostat differential too narrow.	Replace thermostat.
	Plenum gasket not sealing, allowing discharge air to short cycle the thermostat.	Check gasket, reposition or replace.
	Restricted coil or dirty filter.	Clean and advise customer of periodic cleaning of filter.
	Thermostat bulb touching thermostat bulb support bracket.	Adjust bulb bracket. (Applicable models.)

PROBLEM	POSSIBLE CAUSE	TO CORRECT
Prolonged off cycles (automatic operation).	Anticipator (resistor) wire disconnected at thermostat or system switch.	Refer to appropriate wiring diagram.
	Anticipator (resistor shorted or open). (Applicable models.)	Replace thermostat block and resistor.
	Partial loss of charge in thermostat bulb causing a wide differential.	Replace thermostat.

PROBLEM	POSSIBLE CAUSE	TO CORRECT
Switches from cooling to heating.	Thermostat sticking.	Change room thermostat.
	Incorrect wiring.	Refer to appropriate wiring diagram.

PROBLEM	POSSIBLE CAUSE	TO CORRECT
Outside water leaks.	Evaporator drain pan cracked or obstructed.	Repair, clean or replace as required.
	Water in compressor area.	Detach shroud from pan and coil. Clean and remove old sealer. Reseal, reinstall and check.
	Obstructed condenser coil.	Steam clean.
	Fan blade and slinger ring improperly positioned.	Adjust fan blade 3/16 to 1/4" from condenser shroud. Adjust fan motor mount to allow 3/16 to 1/4" clearance between condenser fan blade and base pan.

PROBLEM	POSSIBLE CAUSE	TO CORRECT
High indoor humidity.	Insufficient air circulation in air conditioned area.	Adjust louvers for best possible air circulation.
	Oversized unit.	Operate in "Fan-Auto (Moneysaver)" position.
	Inadequate vapor barrier in building structure, particularly floors.	Advise customer.

WIRING DIAGRAM

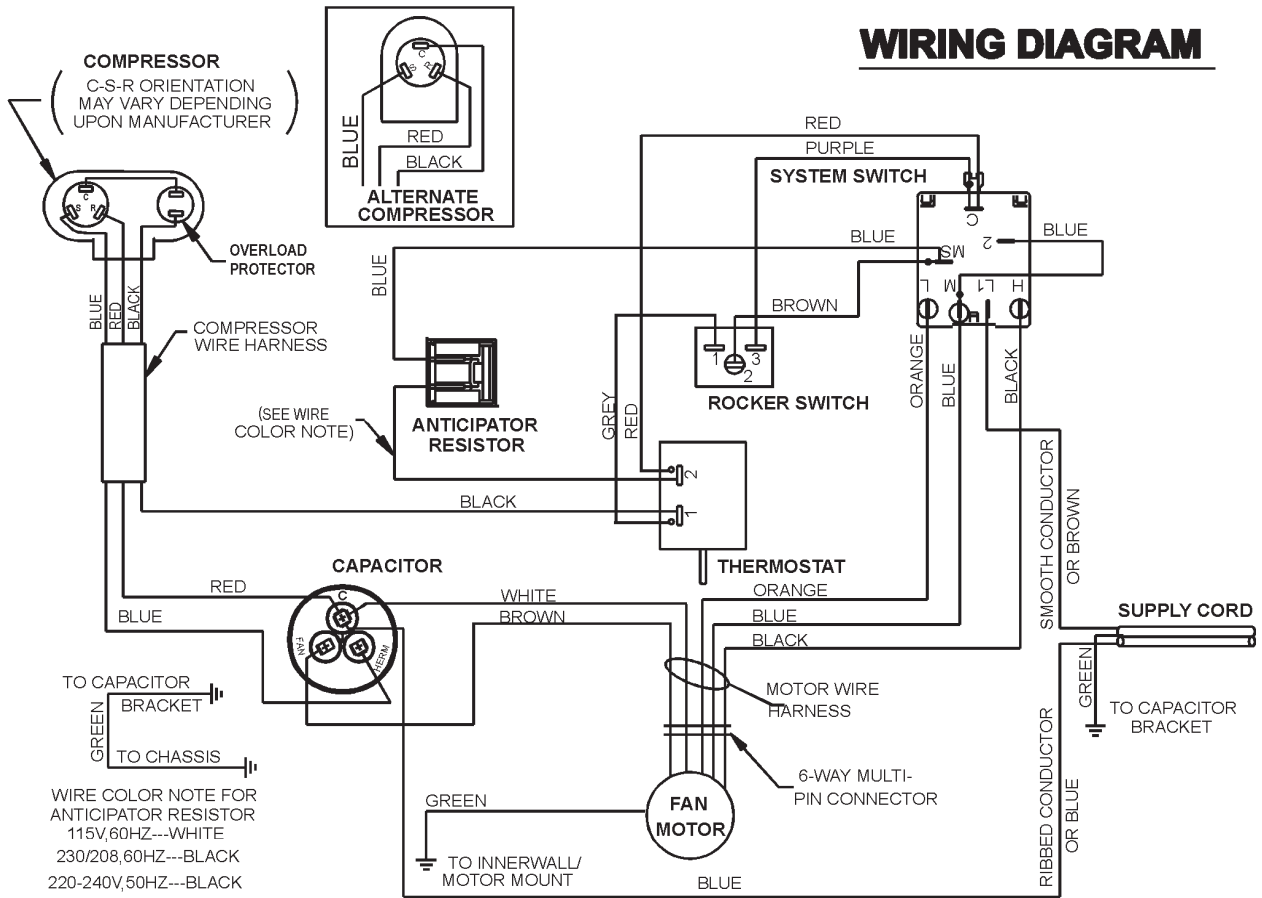

SCHEMATIC

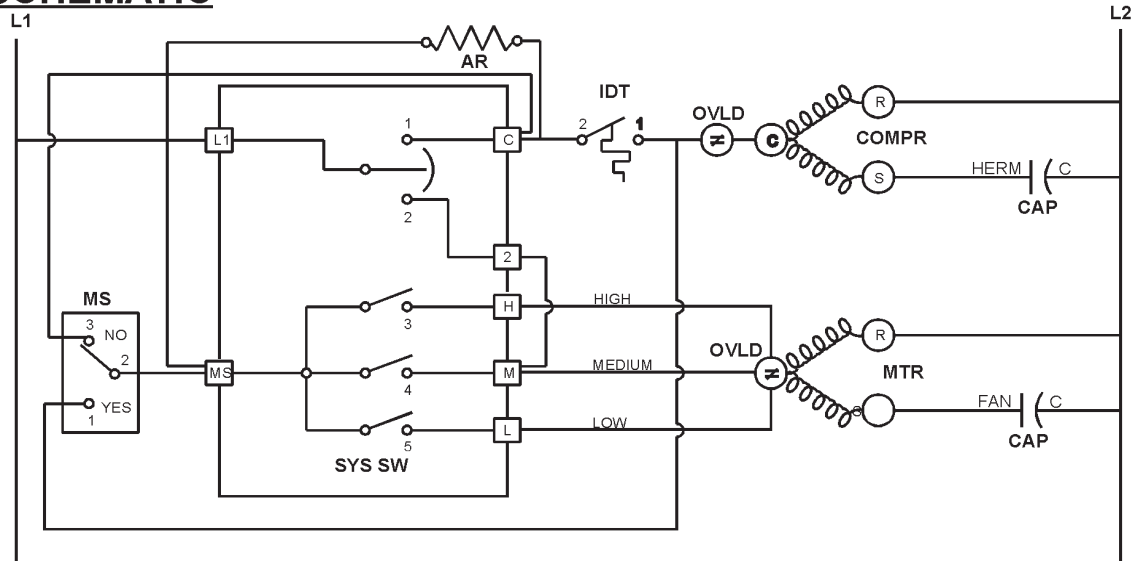

SWITCH LOGIC

X = CLOSED
0 = OPEN

SWITCH POSITION	1	2	3	4	5
OFF	0	0	0	0	0
LOW COOL	X	0	0	0	X
MED COOL	X	0	0	X	0
HI COOL	X	0	X	0	0
FAN ONLY	0	X	0	0	0

LEGEND

- AR - ANTICIPATOR RESISTOR
- MS - MONEY SAVER/ROCKER SWITCH
- CAP - CAPACITOR
- COMPR - COMPRESSOR
- MTR - FAN MOTOR
- OVLD - OVERLOAD PROTECTOR
- SYS SW - SYSTEM SWITCH
- IDT - INDOOR THERMOSTAT

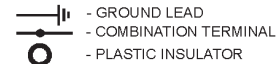

PART NO. 618-200-00
REV. 02

QUIETMASTER "KS" — "KM" SERIES CHASSIS PARTS

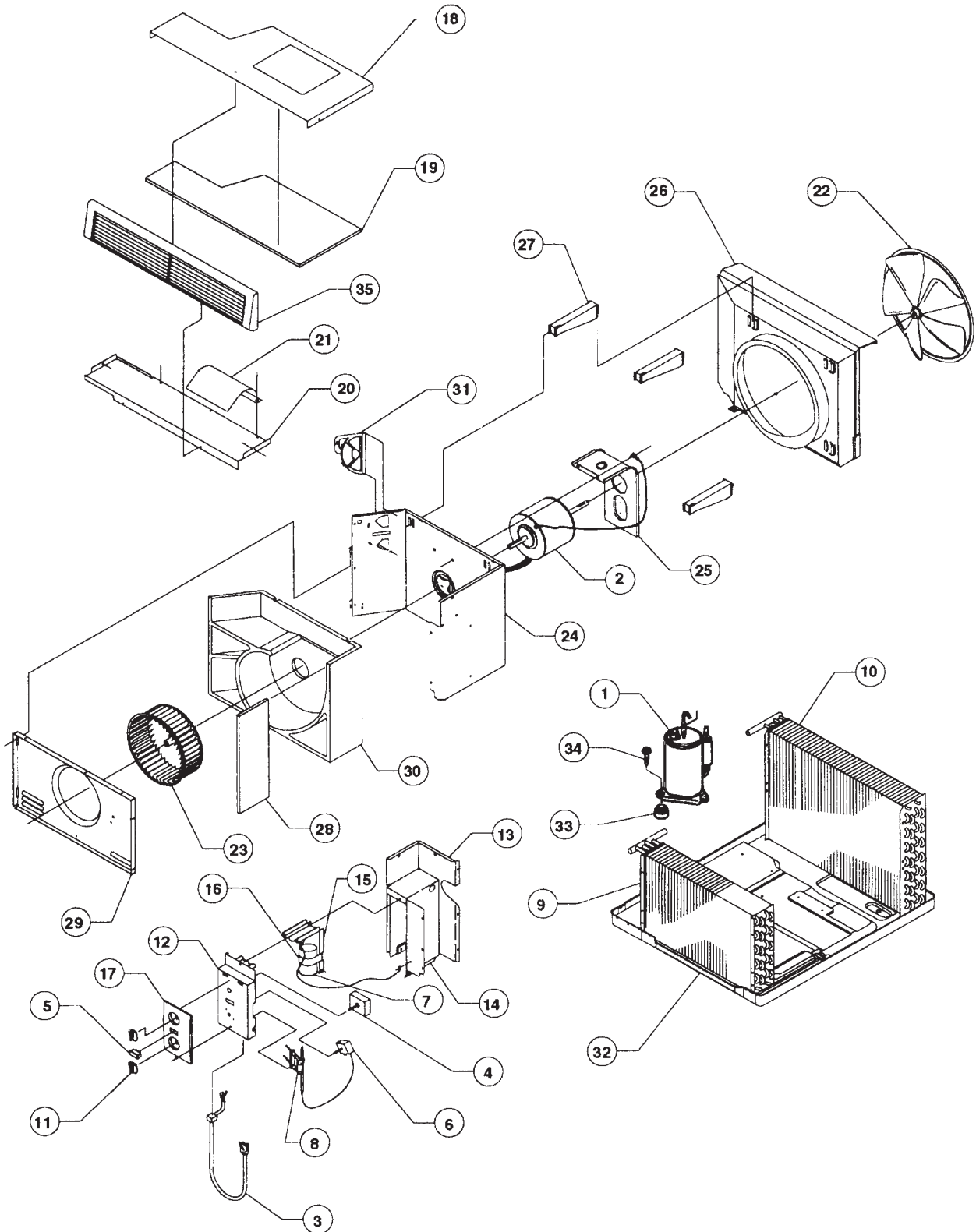

QUIETMASTER "KS" — "KM" SERIES CABINET PARTS

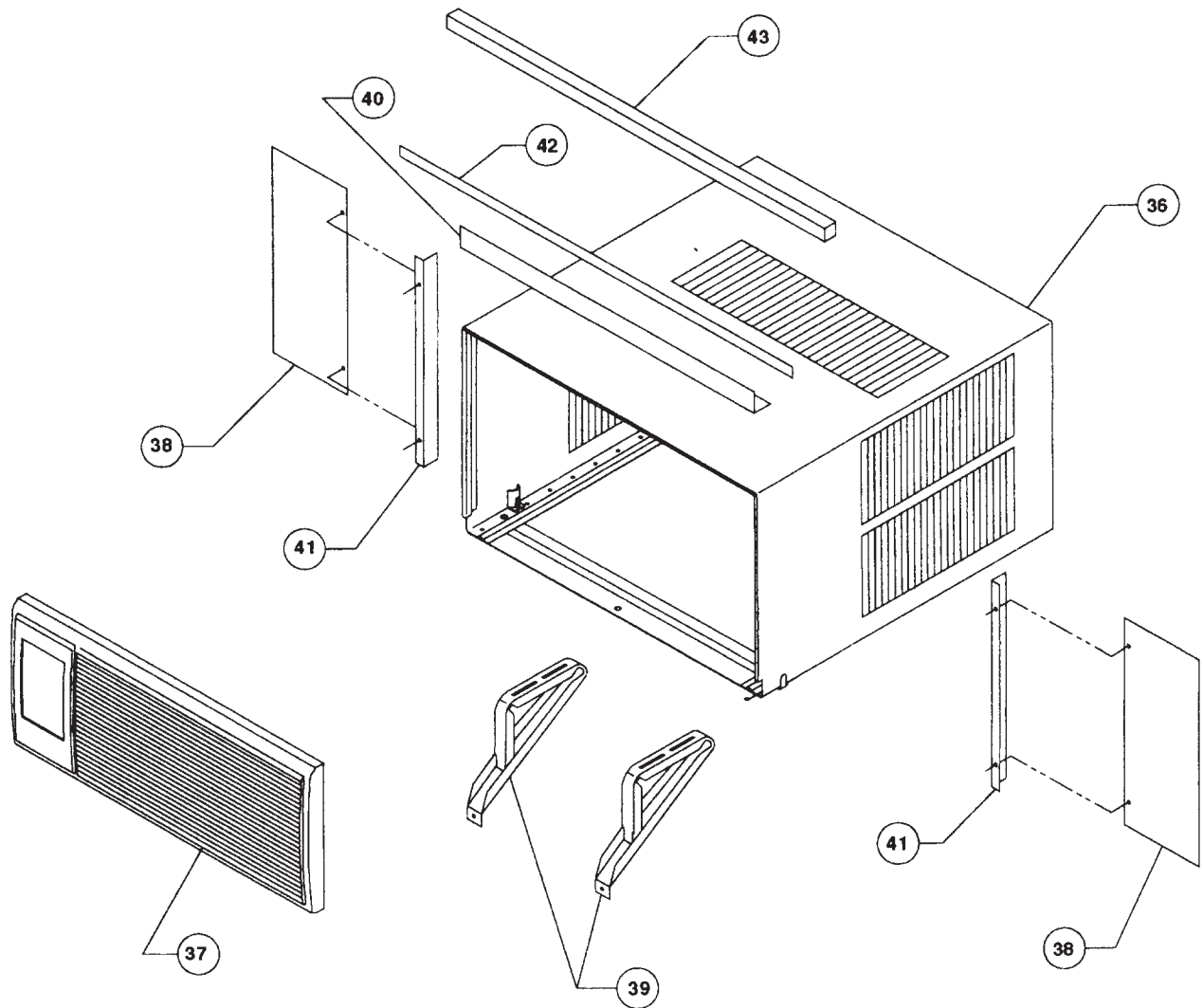

QUIETMASTER "KS" - "KM" SERIES PARTS LIST

REF.	PART NO.	DESCRIPTION	APPLICATION							
			K S	K S	K S	K M	K M			
		ELECTRICAL PARTS								
1	615-628-09	Compressor, Tecumseh, 115 V., 60 Hz., 1 Ph., Model RK5510E	1							
1	615-628-00	Compressor, Tecumseh, 115 V., 60 Hz., 1 Ph., Model RK5512E		1						
1	615-628-04	Compressor, Tecumseh, 115 V., 60 Hz., 1 Ph., Model RK5512EXD			1					
1	617-187-01	Compressor, Bristol, 230/208 V., 60 Hz., 1 Ph., Model H23B175ABCC				1				
1	611-935-46	Compressor, Tecumseh, 230/208 V., 60 Hz., 1 Ph., Model AWF5522EXN						1		
*	603-645-98	Overload, Compressor - MRA3790-114	1							
*	603-645-90	Overload, Compressor - MRA4703-117		1						
*	603-645-96	Overload, Compressor - MRA3794-114			1					
*	615-780-10	Overload, Compressor - MRA98982-117				1				
2	610-714-80	Motor, Fan	1							
2	610-714-93	Motor, Fan		1						
2	610-714-94	Motor, Fan			1					
2	610-714-96	Motor, Fan				1	1			
3	605-000-54	Cord, Electric Supply - 15 Amp., 125 Volt	1							
3	605-000-53	Cord, Electric Supply - 15 Amp., 125 Volt		1						
3	605-000-51	Cord, Electric Supply - 15 Amp., 250 Volt			1	1				
3	605-000-49	Cord, Electric Supply - 20 Amp., 250 Volt						1		
4	606-072-03	System Switch	1	1	1	1	1	1		
5	618-061-00	Rocker Switch	1	1	1	1	1	1		
6	618-225-00	Thermostat	1	1	1	1	1	1		
7	610-803-38	Capacitor, Run - 25/10 MFD, 370 V	1	1						
7	610-803-37	Capacitor, Run - 25/7.5 MFD, 370 V			1					
7	610-803-34	Capacitor, Run - 35/7.5 MFD, 370 V				1	1			
*	618-213-00	Harness Wire, Compressor	1	1	1					
*	618-214-00	Harness Wire, Compressor				1				
*	618-212-00	Harness Wire, Compressor						1		
*	618-208-00	Harness Wire, Fan Motor	1	1	1	1	1	1		
8	618-080-00	Resistor Block - 115 V	1	1						
8	618-080-01	Resistor Block - 230 V			1	1	1			
		REFRIGERATION SYSTEM COMPONENTS								
9	618-501-01	Coil, Evaporator	1							
9	618-501-00	Coil, Evaporator		1						
9	618-500-05	Coil, Evaporator			1					
9	618-500-02	Coil, Evaporator				1	1			
10	618-503-03	Coil, Condenser	1	1	1					
10	618-502-00	Coil, Condenser				1	1			
*	01390212	† Capillary Tube - .059 I.D. x 34" - 39" Long	1		1					
*	03760520	† Capillary Tube - .059 I.D. x 31 5/8" - 35" Long		1						
*	03760545	Capillary Tube - .042 I.D. x 20" Long				3				
*	03760479	Capillary Tube - .049 I.D. x 44" Long						3		
*	603-081-01	Filter - Drier (use when repairing sealed system)	1	1	1	1	1	1		
		CHASSIS PARTS								
11	614-939-05	Knob, Control	2	2	2	2	2	2		
12	618-072-00	Panel, Control	1	1	1					
12	618-110-00	Panel, Control				1	1			
*	600-713-12	Bushing, Snap	1	1	1	1	1	1		

* Not Shown

QUIETMASTER "KS" - "KM" SERIES PARTS LIST

REF.	PART NO.	DESCRIPTION	APPLICATION				
			K S 1 0 J 1 0	K S 1 2 J 1 0	K S 1 2 J 3 0 A	K M 1 8 J 3 0 A	K M 2 1 J 3 0
REFRIGERATION SYSTEM COMPONENTS (Cont.)							
13	618-027-00	Panel Assembly, Left Side	1	1	1		
13	618-042-00	Panel Assembly, Left Side				1	1
14	618-028-00	Partition, Control Box	1	1	1		
14	618-043-00	Partition, Control Box				1	1
15	618-204-00	Bracket, Capacitor Mounting	1	1	1	1	1
16	618-207-00	Strap, Capacitor	1	1	1	1	1
17	618-226-00	Decorative Panel	1	1	1	1	1
*	618-076-00	Grommet, Suction Line	1	1	1	1	1
*	618--148-00	Connector, Fresh Air & Exhaust	1	1	1	1	1
18	618-172-00	Cover, Top	1	1	1	1	1
19	618-167-00	Insulation, Top Cover	1	1	1	1	1
*	618-168-00	Insulation, Left Side Deck	1	1	1	1	1
20	618-171-00	Deck	1	1	1	1	1
*	608-658-08	Filter, Air	1	1	1		
*	608-658-09	Filter, Air				1	1
*	618-230-00	Holder, Filter	2	2	2	2	2
21	618-202-00	Air Foil	1	1	1	1	1
*	618-206-00	Bracket, Resistor Block	1	1	1	1	1
*	915-003-01	Clamp, Supply Cord	1	1	1	1	1
22	605-420-03	Fan Blade	1	1	1		
22	605-420-04	Fan Blade				1	1
23	606-106-03	Blower Wheel	1				
23	606-106-01	Blower Wheel		1	1	1	
23	606-106-05	Blower Wheel					1
24	618-033-00	Inner Wall	1	1	1		
24	618-047-00	Inner Wall				1	1
25	618-025-00	Mount, Motor	1	1	1		
25	618-041-00	Mount, Motor				1	1
26	618-036-00	Shroud	1	1	1		
26	618-049-00	Shroud				1	1
27	618-026-00	Brace, Shroud	3	3	3	3	3
28	618-169-00	Insulation, Inner Wall	1	1	1		
28	618-169-01	Insulation, Inner Wall				1	1
29	618-173-00	Blower Front	1	1	1		
29	618-174-00	Blower Front				1	1
30	618-149-00	Scroll	1	1	1		
30	618-175-00	Scroll				1	1
31	618-215-00	Door Slide Assembly	1	1	1	1	1
32	618-034-05	Base Pan	1	1	1		
32	618-034-18	Base Pan				1	1
32	618-034-01	Base Pan					1
*	618-038-00	Drain Pan	1	1	1	1	
*	618-188-00	Rear Grille	1	1	1		
*	618-188-01	Rear Grille				1	1
33	610-289-00	Grommet, Compressor	3	3	3	3	
33	01150934	Grommet, Compressor					3

* Not Shown

† Capillary length may vary, flow rate is the same.

QUIETMASTER "KS" - "KM" SERIES PARTS LIST

REF.	PART NO.	DESCRIPTION	APPLICATION				
			K S 1 0 J 1 0	K S 1 2 J 1 0	K S 1 2 J 3 0 A	K M 1 8 J 3 0 A	K M 2 1 J 3 0
CHASSIS PARTS (Cont.)							
34	914-004-00	Bolt, Compressor Mounting	3	3	3	3	3
35	618-102-00	Plenum Assembly	1	1	1	1	1
*	618-093-00	Knob, Fresh Air & Exhaust	1	1	1	1	1
*	618-092-00	Lever, Fresh Air & Exhaust	1	1	1	1	1
*	618-062-00	Connector, Louver	2	2	2	2	1
*	618-063-00	Louver, Grille	20	20	20	20	20
*	618-063-01	Louver, with Handle	2	2	2	2	2
36	618-257-00	Outer Shell (with Sill Plate)	1	1	1		
36	618-257-01	Outer Shell (with Sill Plate)				1	1
37	618-089-00	Grille, Intake	1	1	1		
37	618-111-00	Grille, Intake				1	1
*	618-196-00	Guide, Shell	2	2	2	2	
*	618-199-00	Latch, Intake Grille	2	2	2	2	2
38	602-944-08	Wingboard	1	1	1		
38	602-944-09	Wingboard				1	1
*	611-050-04	Accessory Package	1	1	1		
*	611-050-05	Accessory Package				1	1
39	611-095-03	Bracket, Support	2	2	2	2	2
40	618-197-01	Angle, Wingboard (Top)	1	1	1	1	1
41	618-198-01	Angle, Wingboard (Side)	2	2	2		
41	618-198-03	Angle, Wingboard (Side)				2	2
42	606-103-03	Gasket (Vinyl)	1	1	1	1	1
*	608-460-16	Plastic Bag (Hardware)	1	1	1	1	1
*	617-173-01	Gasket, Chassis (Foam)	1	1	1	1	1
*	618-116-03	Carton, Shipping	1	1	1	1	
*	618-116-04	Carton, Shipping				1	1
*	618-139-00	Pad, Shipping	1	1	1	1	1
*	618-118-00	Pad, Shipping	2	2	2		
*	618-118-01	Pad, Shipping				2	2
*	618-141-01	Pad, Shipping (Top)	1	1	1	1	1
43	600-733-00	Gasket, Window (Foam)	1	1	1	1	1
OPTIONAL ACCESSORIES							
*	01900-235	Drain - Condensate Connection Kit, DC-2	x	x	x	x	x
*	01900-312	Start Kit, Capacitor/Relay (Pow-R-Pak)	x	x	x	x	x

* Not Shown

QUIETMASTER "KL" SERIES CHASSIS PARTS

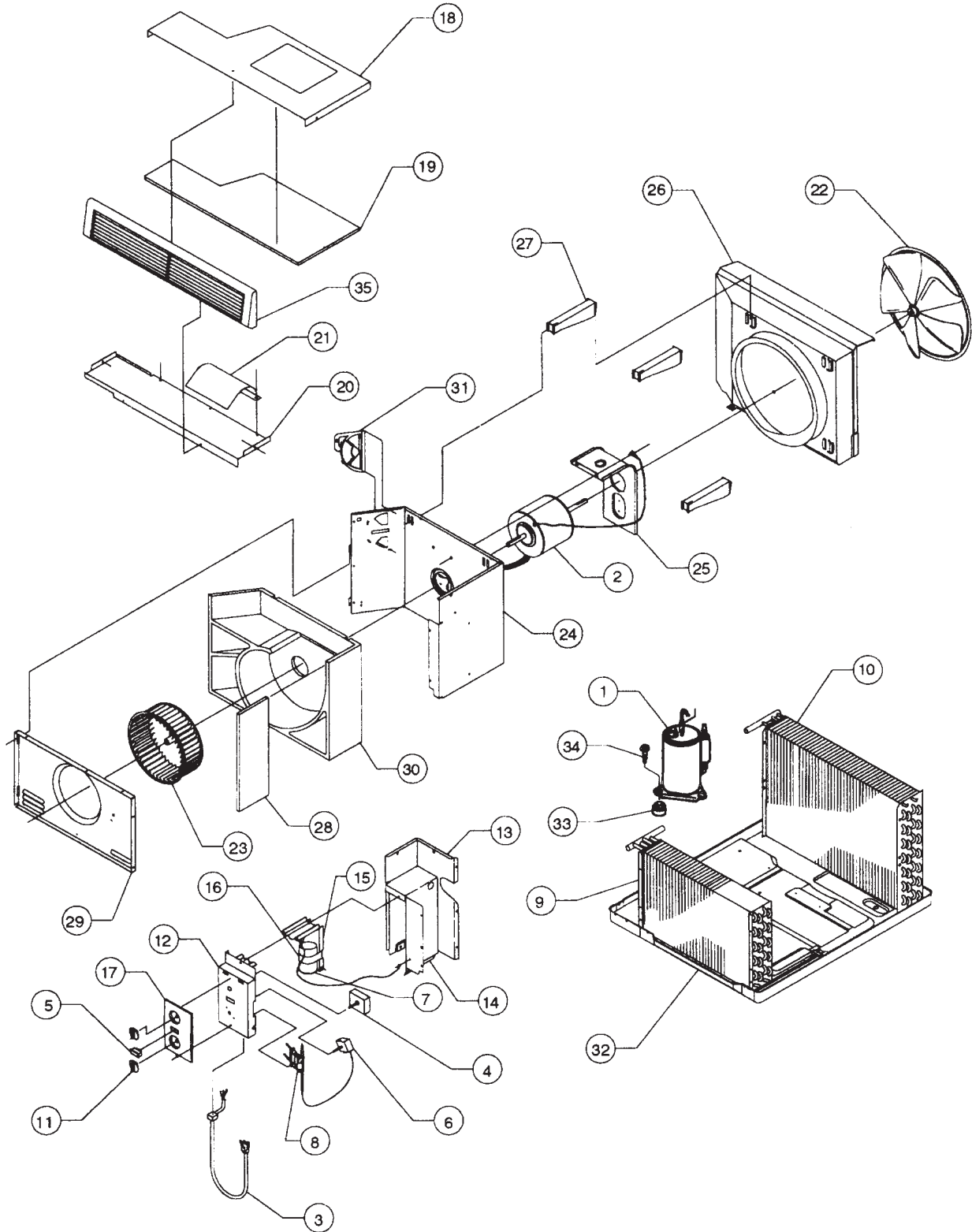

QUIETMASTER "KL" SERIES CABINET PARTS

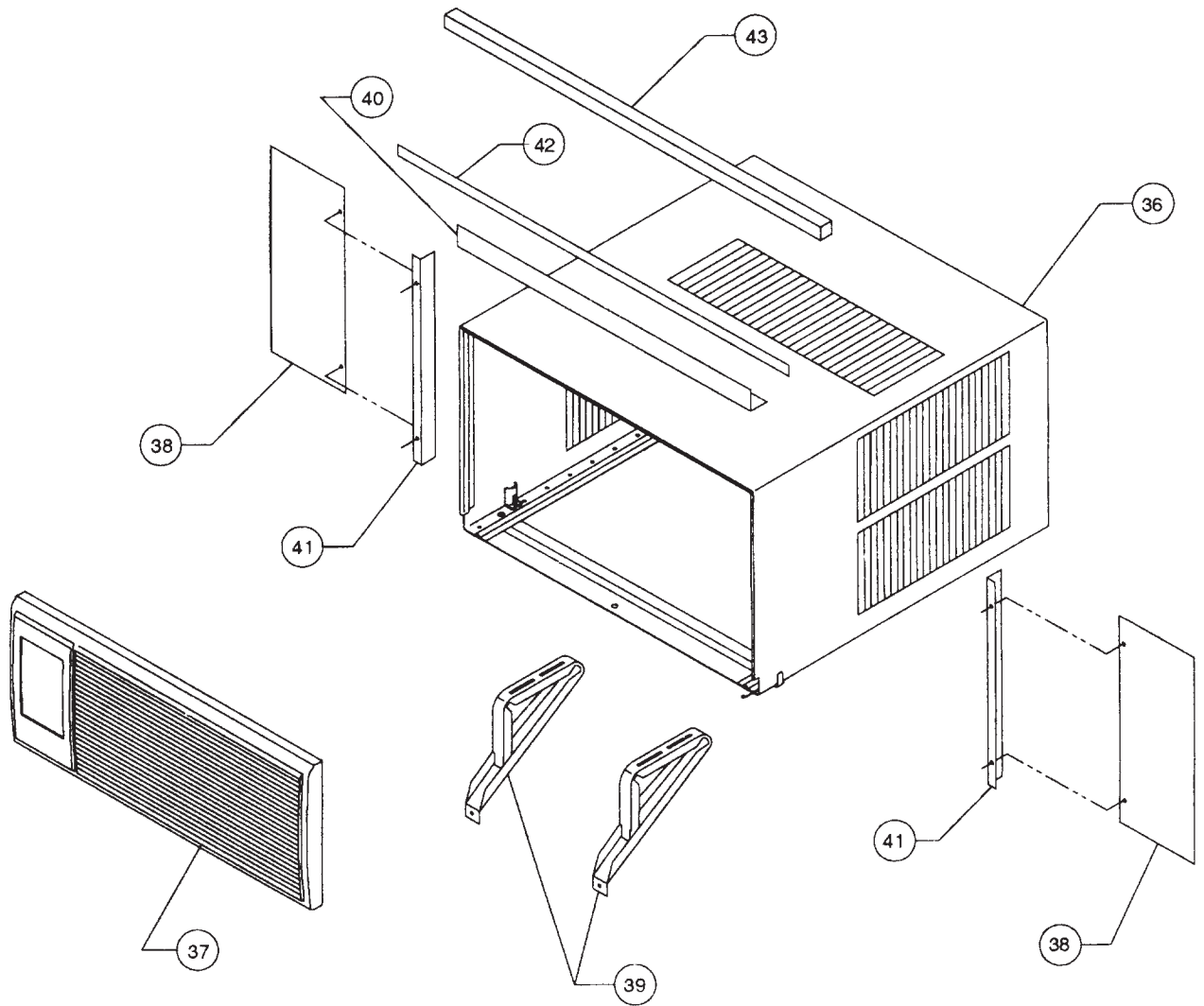

QUIETMASTER "KL" SERIES PARTS LIST

REF.	PART NO.	DESCRIPTION	APPLICATION
<u>ELECTRICAL PARTS</u>			K L 2 5 J 3 0 A
1	615-935-47	Compressor, Tecumseh, 230/208 V., 60 Hz., 1 Ph., Model AWR5524EXN	1
2	610-714-85	Motor, Fan	1
3	605-000-49	Cord, Electric Supply - 20 Amp., 250 Volt	1
4	606-072-03	System Switch	1
5	618-061-00	Rocker Switch	1
6	618-225-00	Thermostat	1
7	610-803-34	Capacitor, Run - 35/7.5 MFD, 370 V	1
*	618-211-00	Harness Wire, Compressor	1
*	618-208-00	Harness Wire, Fan Motor	1
8	618-080-01	Resistor Block - 230 V	1
<u>REFRIGERATION SYSTEM COMPONENTS</u>			
9	618-501-02	Coil, Evaporator	1
10	618-503-07	Coil, Condenser	1
*	03760548	† Capillary Tube - .054 I.D. X 37 1/4" - 40" Long	3
*	614-831-00	Filter Drier (use when repairing sealed system)	1
<u>CHASSIS PARTS</u>			
11	614-939-05	Knob, Control	2
12	618-069-00	Panel, Control	1
*	600-713-12	Bushing, Snap	1
13	618-068-00	Panel, Left Side	1
*	618-176-00	Insulation, Left Side	1
14	618-070-00	Partition, Control Box	1
15	618-204-00	Bracket, Capacitor Mounting	1
16	618-207-00	Strap, Capacitor	1
17	618-226-00	Decorative Panel	1
*	618-076-01	Grommet, Suction Line	1
*	618-148-01	Connector, Fresh Air & Exhaust	1
18	618-179-00	Cover, Top	1
19	618-182-00	Insulation, Top Cover	1
*	618-183-00	Insulation, Left Side Deck	1
20	618-180-00	Deck	1
*	608-658-10	Filter, Air	1
*	618-230-00	Holder, Filter	2
21	618-202-01	Air Foil	1
*	618-206-00	Bracket, Resistor Block	1
*	915-003-01	Clamp, Supply Cord	1
22	605-420-01	Fan, Blade	1
*	Not Shown	† Capillary length may vary, flow rate is the same.	

QUIETMASTER "KL" SERIES PARTS LIST

REF.	PART NO.	DESCRIPTION	APPLICATION
<u>CHASSIS PARTS (Cont.)</u>			K L 2 5 J 3 0 A
23	606-106-02	Blower Wheel	1
24	618-066-00	Inner Wall	1
25	618-067-00	Mount, Motor	1
26	618-077-00	Shroud	1
27	618-100-00	Brace, Shroud	3
28	618-169-02	Insulation, Inner Wall	1
29	618-178-00	Blower Front	1
30	618-181-00	Scroll	1
31	618-215-00	Door, Slide Assembly	1
32	318-071-01	Base Pan	1
*	618-074-00	Drain Pan	1
*	618-188-02	Grille, Rear	1
33	01150934	Grommet, Compressor	3
34	914-004-00	Bolt, Compressor Mounting	3
35	618-105-00	Plenum Assembly	1
*	618-093-00	Knob, Fresh Air & Exhaust	1
*	618-096-00	Connector, Louver	2
*	618-097-00	Louver, Grille	20
*	618-097-01	Louver, with Handle	2
*	618-092-00	Lever, Fresh Air & Exhaust	1
36	618-257-02	Outer Shell (with Sill Plate)	1
*	618-084-01	Sill Plate	1
37	618-104-00	Grille, Intake	1
*	618-199-00	Latch, Intake Grille	2
38	602-944-10	Wingboard	1
*	611-050-03	Accessory Package	1
39	611-095-03	Bracket, Support	2
40	618-197-03	Angle, Wingboard (Top)	1
41	618-198-05	Angle, Wingboard (Side)	2
42	606-103-03	Gasket (Vinyl)	1
*	608-460-16	Plastic Bag (Hardware)	1
*	617-173-01	Gasket, Chassis (Foam)	1
*	618-116-05	Carton, Shipping	1
*	618-140-00	Pad, Shipping (Bottom)	1
*	618-141-00	Pad, Shipping (Top)	1
*	618-118-02	Pad, Shipping (Front & Rear)	2
*	618-196-00	Guide, Shell	2
43	600-733-00	Gasket, Window (Foam)	1
<u>OPTIONAL ACCESSORIES</u>			
*	01900-235	Drain - Condensate Connection Kit, DC-2	x
*	01900-312	Start Kit, Capacitor/Relay (Pow-R-Pak)	x

Use Factory Certified Parts . . .

Friedrich[®]

Friedrich Air Conditioning Co.

4200 North Pan Am Expressway • P.O. Box 1540

San Antonio, Texas 78295-1540 • U.S.A.

Phone: (210) 357-4400

Fax: (210) 357-4480

Free Manuals Download Website

<http://myh66.com>

<http://usermanuals.us>

<http://www.somanuals.com>

<http://www.4manuals.cc>

<http://www.manual-lib.com>

<http://www.404manual.com>

<http://www.luxmanual.com>

<http://aubethermostatmanual.com>

Golf course search by state

<http://golfingnear.com>

Email search by domain

<http://emailbydomain.com>

Auto manuals search

<http://auto.somanuals.com>

TV manuals search

<http://tv.somanuals.com>