

INSTRUCTIONS-PARTS LIST



307741

Rev. R



This manual contains important warnings and information.
READ AND KEEP FOR REFERENCE.

INSTRUCTIONS

First choice when quality counts.™

255 mm (10 in.) DIAMETER

Quiet King[®] Air Motor

0.6 MPa, 6.2 bar (90 psi) Maximum Working Pressure

Part No. 220106, Series A

Standard Quiet Air Motor

Part No. 235525, Series B

Quiet Air Motor

Part No. 237000, Series A

Reduced Icing Quiet Air Motor

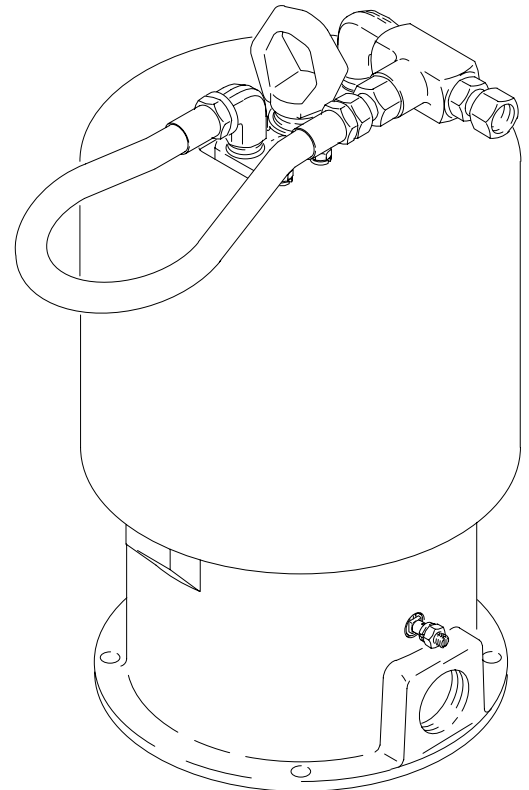

03695A



Model 220106 Shown

GRACO INC. P.O. BOX 1441 MINNEAPOLIS, MN 55440-1441

©COPYRIGHT 1985, GRACO INC.

Graco Inc. is registered to I.S. EN ISO 9001

Table of Contents

Warnings	2
Installation	5
Troubleshooting	7
Service	10
Parts	18
Dimensions	24
Technical Data	25
Warranty	28
Graco Phone Number	28

Symbols

Warning Symbol



This symbol alerts you to the possibility of serious injury or death if you do not follow the instructions.

Caution Symbol



This symbol alerts you to the possibility of damage to or destruction of equipment if you do not follow the instructions.

! WARNING



INSTRUCTIONS

EQUIPMENT MISUSE HAZARD

Equipment misuse can cause the equipment to rupture or malfunction and result in serious injury.

- This equipment is for professional use only.
- Read all instruction manuals, tags, and labels before operating the equipment.
- Use the equipment only for its intended purpose. If you are uncertain about usage, call your Graco distributor.
- Do not alter or modify this equipment. Use only genuine Graco parts and accessories.
- Check equipment daily. Repair or replace worn or damaged parts immediately.
- Do not exceed the maximum working pressure stated on the equipment or in the **Technical Data** for your equipment. Do not exceed the maximum working pressure of the lowest rated component in your system.
- Use fluids and solvents which are compatible with the equipment wetted parts. Refer to the **Technical Data** section of all equipment manuals. Read the fluid and solvent manufacturer's warnings.
- Do not use hoses to pull equipment.
- Route hoses away from traffic areas, sharp edges, moving parts, and hot surfaces. Do not expose Graco hoses to temperatures above 82°C (180°F) or below -40°C (-40°F).
- Wear hearing protection when operating this equipment.
- Do not lift pressurized equipment.
- Do not lift the equipment by the air motor lift ring if the total weight of the equipment exceeds 550 lb (250 kg).
- Comply with all applicable local, state, and national fire, electrical, and safety regulations.

! WARNING



INJECTION HAZARD

Spray from the gun/valve, hose leaks, or ruptured components can inject fluid into your body and cause extremely serious injury, including the need for amputation. Fluid splashed in the eyes or on the skin can also cause serious injury.



- Fluid injected into the skin might look like just a cut, but it is a serious injury. **Get immediate medical attention.**
- Do not point the gun/valve at anyone or at any part of the body.
- Do not put your hand or fingers over the spray tip/nozzle.
- Do not stop or deflect leaks with your hand, body, glove or rag.
- Do not “blow back” fluid; this is not an air spray system.
- Always have the tip guard and the trigger guard on the gun when spraying.
- Check the spray gun diffuser operation weekly. Refer to the gun manual.
- Be sure the gun/valve trigger safety operates before spraying/dispersing.
- Lock the gun/valve trigger safety when you stop spraying/dispersing.
- Follow the **Pressure Relief Procedure** on page 7 whenever you: are instructed to relieve pressure; stop spraying/dispersing; clean, check, or service the equipment; and install or clean the spray tip/nozzle.
- Tighten all fluid connections before operating the equipment.
- Check the hoses, tubes, and couplings daily. Replace worn, damaged, or loose parts immediately. Permanently coupled hoses cannot be repaired; replace the entire hose.
- Use only Graco approved hoses. Do not remove any spring guard that is used to help protect the hose from rupture caused by kinks or bends near the couplings.



MOVING PARTS HAZARD

Moving parts, such as the air motor piston, can pinch or amputate your fingers.

- Keep clear of all moving parts when starting or operating the pump.
- Before servicing the equipment, follow the **Pressure Relief Procedure** on page 7 to prevent the equipment from starting unexpectedly.

WARNING



FIRE AND EXPLOSION HAZARD

Improper grounding, poor ventilation, open flames or sparks can cause a hazardous condition and result in a fire or explosion and serious injury.

- Ground the equipment and the object being sprayed. Refer to **Grounding** on page 5.
- If there is any static sparking or you feel an electric shock while using this equipment, **stop spraying/dispensing immediately**. Do not use the equipment until you identify and correct the problem.
- Provide fresh air ventilation to avoid the buildup of flammable fumes from solvents or the fluid being sprayed/dispensed.
- Keep the spray/dispense area free of debris, including solvent, rags, and gasoline.
- Electrically disconnect all equipment in the spray/dispense area.
- Extinguish all open flames or pilot lights in the spray/dispense area.
- Do not smoke in the spray/dispense area.
- Do not turn on or off any light switch in the spray/dispense area while operating or if fumes are present.
- Do not operate a gasoline engine in the spray/dispense area.



TOXIC FLUID HAZARD

Hazardous fluid or toxic fumes can cause serious injury or death if splashed in the eyes or on the skin, inhaled, or swallowed.

- Know the specific hazards of the fluid you are using.
- Store hazardous fluid in an approved container. Dispose of hazardous fluid according to all local, state and national guidelines.
- Always wear protective eyewear, gloves, clothing and respirator as recommended by the fluid and solvent manufacturer.

Installation

General Information

NOTE: Reference numbers and letters in parentheses in the text refer to the callouts in the figures and the parts drawing.

NOTE: Always use Genuine Graco Parts and Accessories, available from your Graco distributor.

Grounding

⚠ WARNING

FIRE AND EXPLOSION HAZARD
Before operating the pump, ground the system as explained below. Also read the section **FIRE AND EXPLOSION HAZARD** on page 4.

1. *Pump:* Use a ground wire and clamp as shown in Fig. 1. Loosen the grounding lug locknut (W) and washer (X). Insert one end of a 12 ga (1.5 mm²) minimum ground wire (Y) into the slot in lug (Z) and tighten the locknut securely. Connect the other end of the wire to a true earth ground.
2. *Air and fluid hoses:* Use only electrically conductive hoses.
3. *Air compressor:* Follow manufacturer's recommendations.
4. *Spray gun or dispensing valve:* Ground through connection to a properly grounded fluid hose and pump.
5. *Object being sprayed:* Follow your local code.
6. *Fluid supply container:* Follow your local code.
7. *Solvent pails used when flushing:* Follow your local code. Use only metal pails, which are conductive, placed on a grounded surface. Do not place the pail on a nonconductive surface, such as paper or cardboard, which interrupts the grounding continuity.
8. *To maintain grounding continuity when flushing or relieving pressure,* hold a metal part of the spray gun/dispense valve firmly to the side of a grounded metal pail, then trigger the gun/valve.

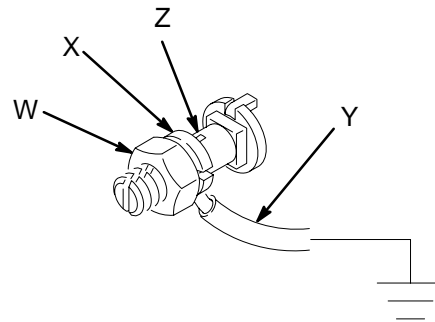

Fig. 1

Installation

Noise Reduction

Instruction Manual 307375 is supplied with this motor. It provides information on noise reduction.

The following are additional recommendations for Maximum Noise Reduction:

- The air line should be connected to the air motor inlet with an electrically conductive flexible hose. Also, use flexible fluid outlet and suction hoses. Where possible, avoid using solid plumbing, which carries noise vibrations.
- Mount the air motor on resilient rubber pads, rather than sheet metal.
- Determine minimum air inlet pressure and pump cycle rate to achieve desired spray/dispensing results or minimum fluid pressure and flow. This will result in less system wear and less overall noise.

Air Motor Icing

Moisture in the compressed air can collect in the air motor and freeze, causing the motor to stall. This is called icing. If icing occurs, shut off the air supply and allow the ice to thaw.

To minimize icing, reduce the moisture in your compressed air supply by using an air dryer or a filter which traps water.

Slope the main air line slightly downward so water will collect at the end of the line, where it can be drained. Additionally, plumb each drop line from the top of the main air line. Install an automatic drain or a drain valve at the bottom of each drop.

Model 237000 Reduced Icing Air Motor allows you to divert a stream of air over the air valves. This flow of warm air prevents water from collecting and freezing. The amount of air is adjustable with a needle valve (88, see the parts drawing on page 22).

For additional help in designing your system, contact your Graco distributor.

Troubleshooting

Pressure Relief Procedure

WARNING



INJECTION HAZARD

To reduce the risk of serious injury, including fluid injection, splashing in the eyes or on the skin, or moving parts, always follow the **Pressure Relief Procedure** whenever you

- are instructed to relieve the pressure
- shut off the pump
- stop spraying/dispersing
- check or service any of the system equipment
- install or clean the spray tips/nozzles

1. Lock the gun/valve trigger safety.
2. Turn off the air to the motor.
3. Close the bleed-type master air valve (required in your system).
4. Unlock the gun/valve trigger safety. Hold a metal part of the gun/valve firmly to a grounded metal pail. Trigger the gun/valve to relieve pressure.
5. Lock the gun/valve trigger safety.
6. Open the fluid drain valve. Leave the fluid drain valve open until you are ready to spray/disperse again.

*If you suspect that the spray tip/nozzle or hose is completely clogged, or that pressure has not been fully relieved after following the steps above, **very slowly** loosen the tip guard retaining nut or hose end coupling to relieve pressure gradually, then loosen completely. Now clear the tip/nozzle or hose obstruction.*

Stalled Motor

To restart a stalled motor, close the bleed-type master air valve to bleed off all trapped air pressure. Turn the air back on. This will trip the air valve of the air motor, causing the piston to go to the top or bottom of its stroke.

WARNING



MOVING PARTS HAZARD

The piston in the air motor moves when air is supplied to the motor. Moving parts can pinch or amputate your fingers or other body parts. Relieve the pressure before servicing the motor.

If Motor Will Not Operate

Check the following areas for damage or wear and replace parts as needed.

Air valving mechanism: director valve (3), spring (4), air valve housing (5), valve plate (2), valve plate seal (1).

Trip rod: check for broken spring or bent rod (40). Do not attempt to repair the trip rod.

Damaged toggle mechanism: guide (16), spring (17), housing (18), pin (19).

Troubleshooting

Air Leaks

Air leaks are caused by worn or damaged gaskets or seals. To locate the leaks, first shut off the air supply to the pump and open the bleed-type master air valve to relieve air pressure. Disconnect the main air supply line from the air inlet. Remove the shield (27) as explained on page 10, then reinstall the other parts and connect the main air line to the inlet.

Open the bleed-type master air valve and adjust the air pressure to .07–0.1 MPa, 0.7–1.0 bar (10–15 psi). Stall the pump on both the up and down stroke as indicated in the **Check Chart** below. Use the methods listed in the **Check Chart** to find where air is leaking. See Fig. 2.

 **WARNING**



MOVING PARTS HAZARD
Keep your fingers away from all moving parts while performing this test, to reduce the risk of pinching or amputating your fingers. Reinstall the air motor shield before resuming normal operation of the pump.

Check for air leaks by feeling, listening, or squirting oil around the suspected area. The oil will bubble if there is a leak.

CHECK CHART

Stroke Position	Letter Ref. Points	Check Method	Cause of Leakage
UP stroke only	F	By listening for air leak at exhaust outlets	Worn trip rod packing (65).
	B	By feel	Blown air cylinder gasket (35).
	C	Squirt oil around wiper (44)	Worn throat packing (46).
	G	By feel	Damaged cylinder gasket (38).
DOWN stroke only	D	By feel.	Damaged air manifold gasket (30).
BOTH strokes	E	By feeling exhaust, or hearing a high-pitched sound	Worn director valve (3). Replace, or lap faces with no. 500 grit sandpaper.
	F	By feel, or hearing a high-pitched sound	Worn piston o-ring (33).
	D or G	By feel	Blown manifold gaskets (38 and 30).
	H	Squirt oil around o-ring (15)	Damaged housing o-ring (15).
	K	By feel	Damaged o-ring (26).

Troubleshooting

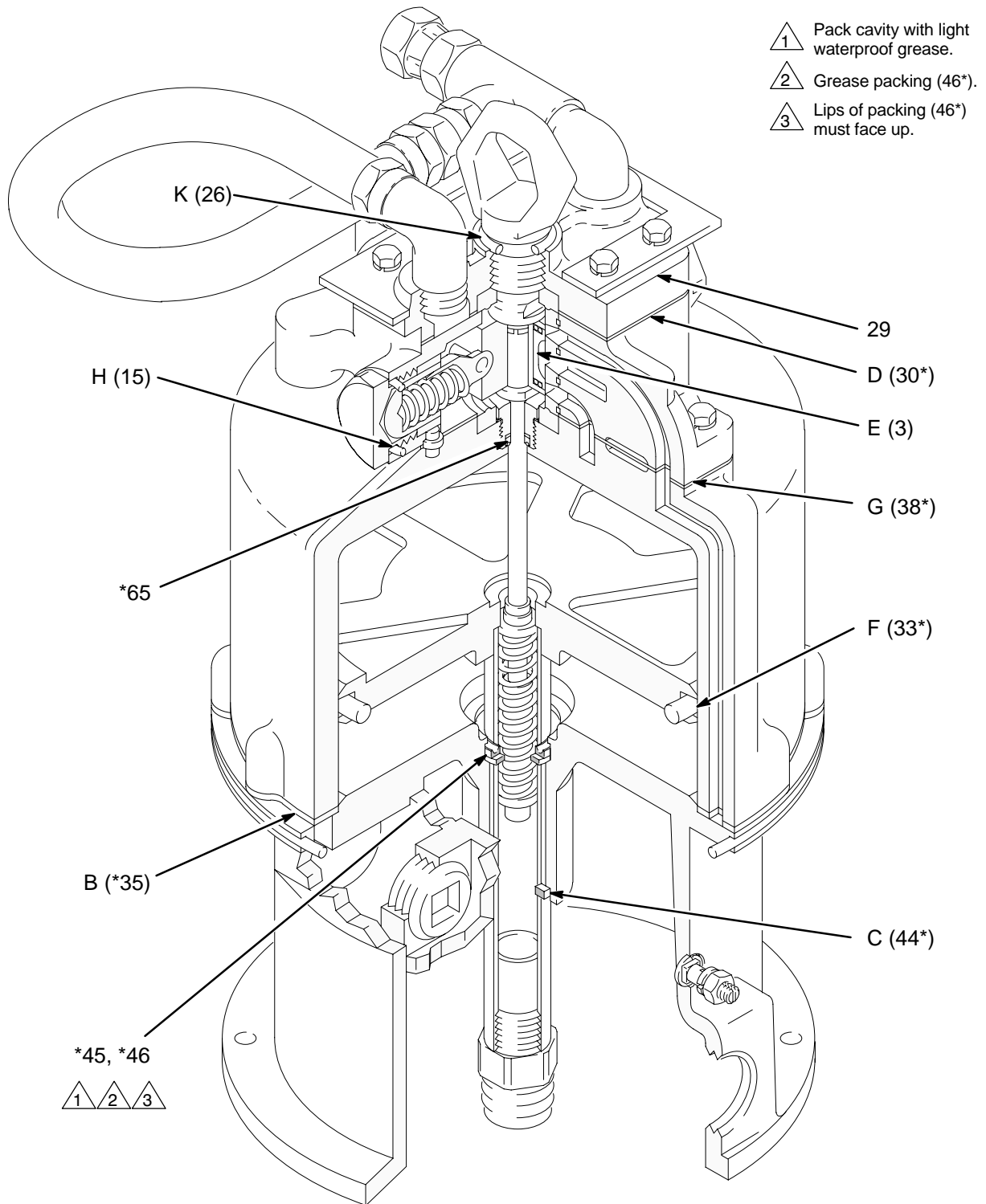

Model 220106 Shown

03705A

Fig. 2

Service

⚠ WARNING



To avoid serious injury and equipment damage, do not lift the equipment by the air motor lift ring if the total weight of the equipment exceeds 550 lb (250 kg). The lift ring cannot support that weight.

Tools Required

- Padded pliers, Part No. 207579 (for use on trip rod).
- Torque wrench
- 1 in. deep well socket wrench
- Set of socket or box wrenches
- Adjustable wrench
- O-ring pick
- Light waterproof grease
- Loctite® 242 or equivalent

Disassembly

NOTE: Repair Kit 220153 is available. Parts included are marked with an asterisk, for example (30*). For the best results, use all the new parts in the kit.

NOTE: Inspect all parts as they are disassembled and replace worn or damaged parts.

⚠ WARNING

To reduce the risk of serious injury whenever you are instructed to relieve pressure, always follow the **Pressure Relief Procedure** on page 7.

1. Relieve the pressure.
2. Disconnect the air hose from the air inlet swivel (68). Disconnect the displacement pump from the motor.

NOTE: Refer to Fig. 3 for steps 3 to 5.

3. To remove the shield, perform step a or b, as applicable.
 - a. *For Models 220106 and 235525:* Remove the lift ring (25), o-ring (26), screws (24), lock-washers (23), air inlet assembly, and shield (27). See Fig. 3.

- b. *For Model 237000:* See page 22. Remove the lift ring (25), o-ring (26), screws (24), lock-washers (23), air inlet fitting (68), and mufflers (76). Remove the air tube (83) from the fitting (87) and push it down through the grommet (81). Remove the shield (27).

4. Remove the gasket (53). Lift off the manifold cap (29). Remove the gasket (30).
5. Unscrew the toggle retainers (14), and remove the o-rings (15), housing guides (16), springs (17), housings (18), and pins (19) from each side of the manifold (20).

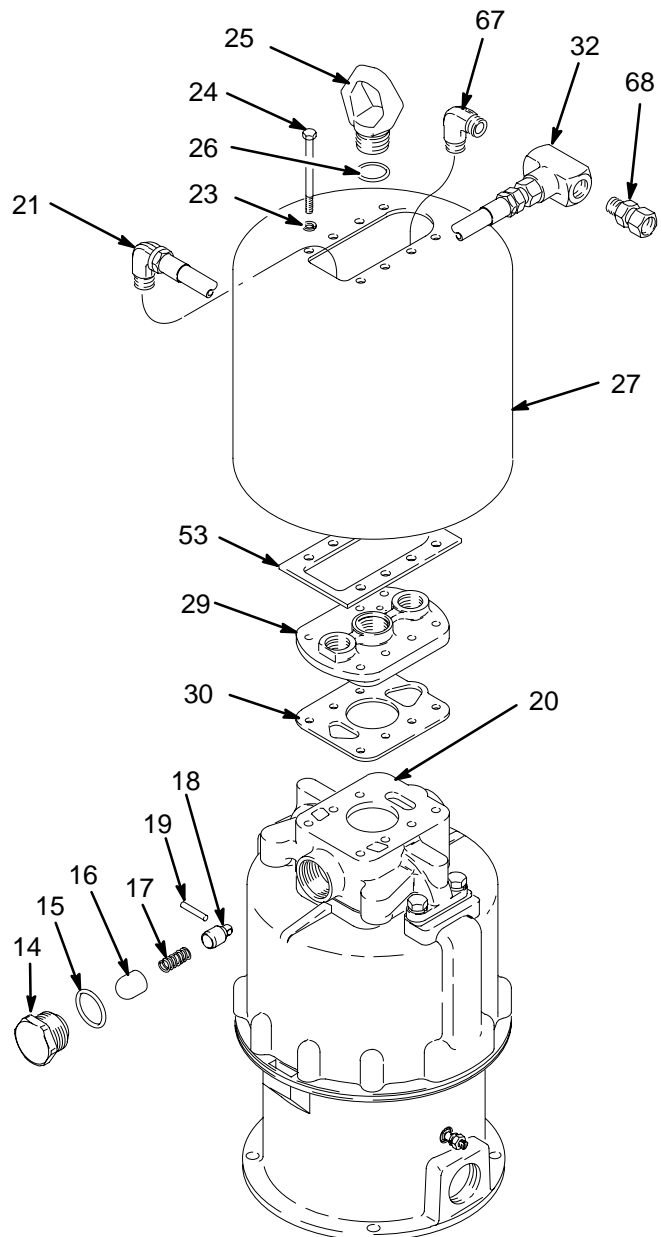

Model 220106 Shown

07281A

Fig. 3

Service

NOTE: Refer to Fig. 4 for steps 6 to 11.

6. Remove the screws (31) and lockwashers (13) from the manifold (20).
7. **To prevent the spring-loaded director valves (3) from popping out**, carefully lift the manifold (20) up about 51 mm (2 in.) from the cylinder (36). Place one hand under the manifold to hold the director valves in the valve housing (5), then continue lifting the manifold. Remove your hand slowly, allowing the valve springs to release gently. Inspect the director valves (3) and compression springs (4).
8. Turn the manifold (20) over. Place wrenches on the flats of the adjusting screw (11) and nut (12) and turn the screw further into the nut until you can remove it. Do this in all four positions.

⚠ WARNING

The openings in the valve plates (2) are very sharp. Be careful not to cut yourself.

9. Remove and check the valve plates (2), handling them carefully. Clean the plates and mating surfaces of the manifold (20). Remove the rubber pad (8).

NOTE: If you replace the valve plates, also replace the seals (1).

⚠ CAUTION

Be careful not to damage the surface of the trip rod (40), which would restrict its free movement. Special padded pliers, 207579, are available.

10. Pull the trip rod (40) up and grasp it with the padded locking pliers (order 207579). Hold the flats of the valve housing hub (10) with a wrench, screw off the trip rod nut (7) and remove the air valve housing (5). Remove the lockwasher (6) and screw off the hub (10). Now release the pliers.

11. Remove the gasket (38) from the air cylinder (36).

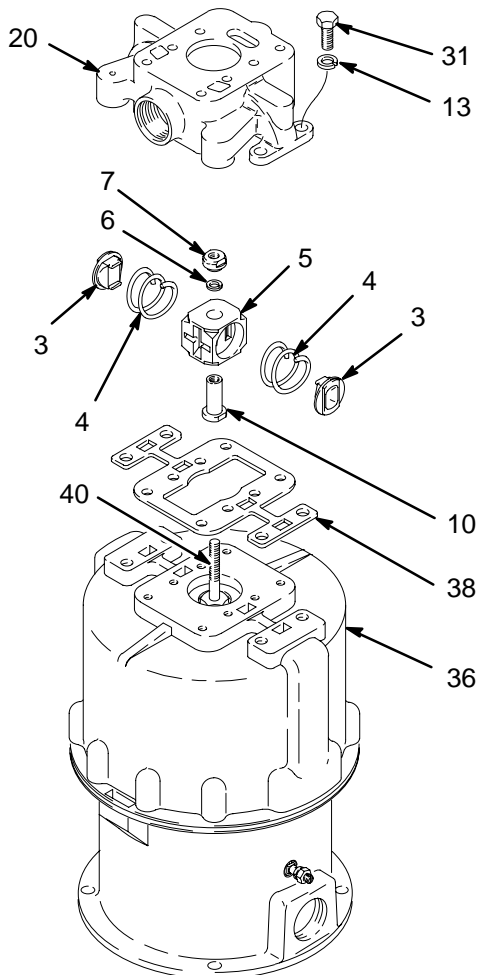

Detail of Air Manifold and Valve Plates

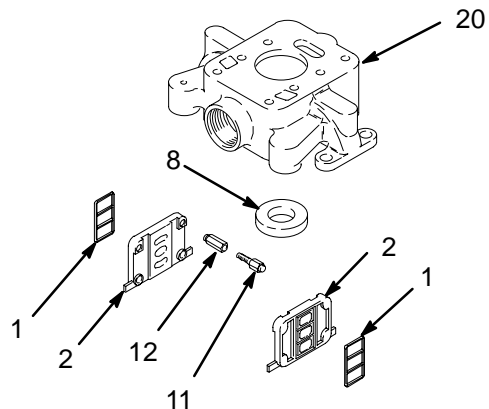

Fig. 4

07282A

Service

NOTE: Refer to Fig. 5 for steps 12 to 18.

12. Remove the rubber pad (8) from the cylinder (36). Remove the trip rod bearing (37), using a 1 in. deep-well socket wrench. Remove the gasket (66), v-block packing (65), and backup washer (64) from the bearing.

CAUTION

Be careful not to tilt the cylinder when removing it from the piston to avoid damaging the smooth inner surface of the cylinder.

13. Remove the screws (31) and lockwashers (13) and carefully pull the cylinder straight up off the piston (34).
14. Pull the piston (34) and trip rod (40) up out of the base (47). Remove the o-ring (33) from the piston.

NOTE: The connecting rod stud (39) is fastened to the piston shaft (34) with anaerobic sealant, and may be difficult to remove.

CAUTION

Be careful not to damage the polished surface of the piston shaft.

15. Lock the hex of the piston shaft (34) in a vise and unscrew the connecting rod stud (39) from the piston shaft.

CAUTION

Handle the trip rod assembly (40) carefully. Nicks and scratches cause premature spring failure.

NOTE: A damaged trip rod cannot be repaired; use a new one.

16. Remove the trip rod (40) from the piston (34).
17. Remove the v-block packing (46), backup washer (45), o-ring (41), and gasket (35) from the base (47).
18. Turn the base over and remove the wiper seal (44). Inspect the bearing (70) in place. Remove only if damaged.

Service

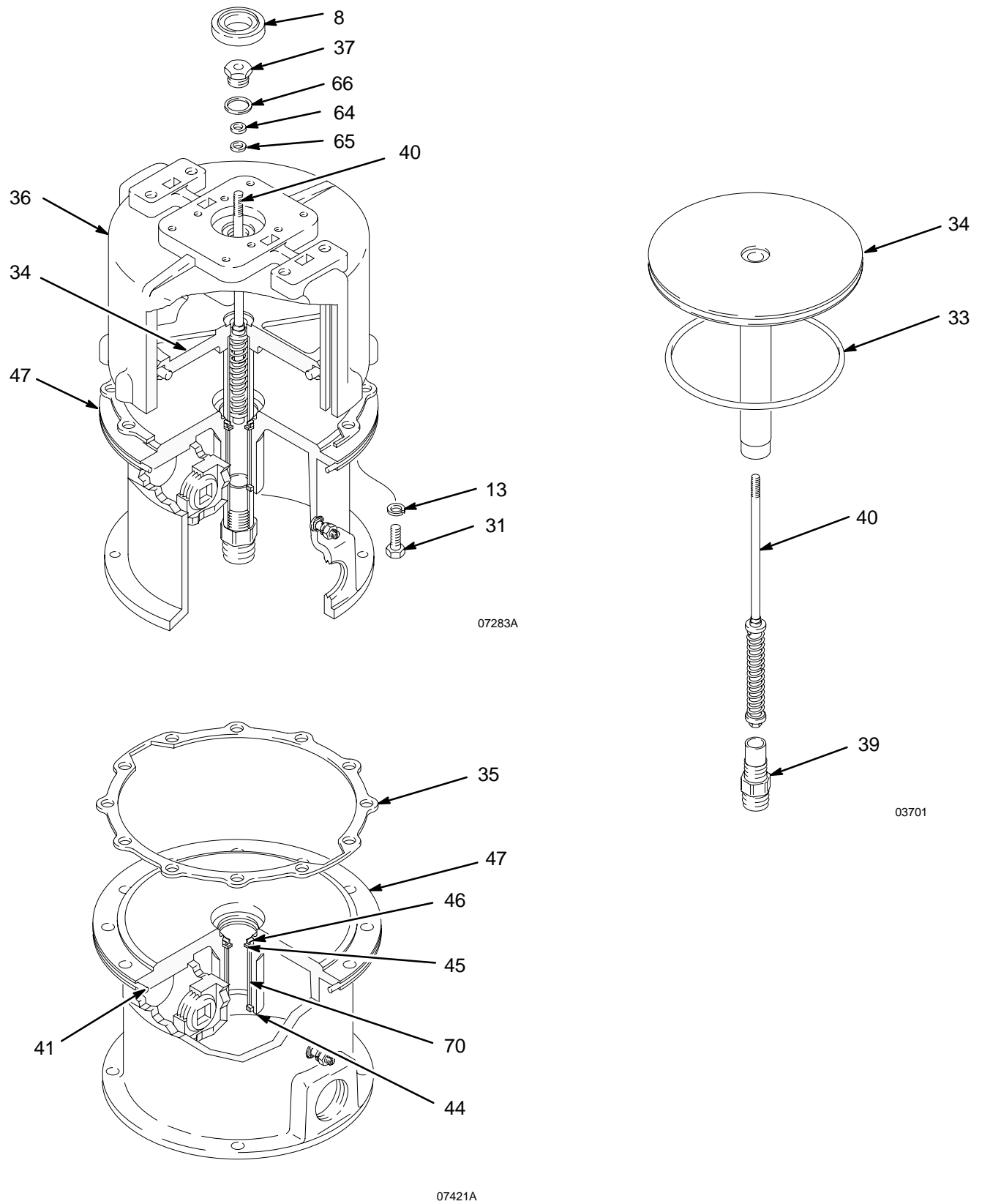

Fig. 5

Service





Reassembly

1. Clean all parts thoroughly and inspect for wear or damage. Replace parts as necessary.

NOTE: Refer to Fig. 6 for steps 2 to 5.

2. Turn the base (47) upside down. If the bearing (70) was removed, press-fit the new bearing so its top edge is flush with the shoulder (S) of the packing cavity. After installation, measure the inner diameter of the bearing. It must be uniformly 35 mm (1.375 in.) to ensure that the piston shaft does not bind. If incorrect, size the bearing while in place; this can be done with a 35 mm (1.375 in.) diameter steel ball.

3. Grease the wiper seal (44*) and press-fit in the base (47).
4. Turn the base upright. Install the backup washer (45*) in the base (47). Grease the v-block packing (46*) and install it in the base so the lips face up.
5. Place the o-ring (41) onto the air motor base (47). Place the gasket (35*) on the base so one of its notches (K) aligns with the optional fluid outlet (L).

- 1  Inner diameter of the bearing must be uniformly 35 mm (1.375 in.).
- 2  Grease.
- 3  Lips of packing must face up.
- 4  Align notch (K) in gasket (35) with the optional fluid outlet (L) in the base (47).

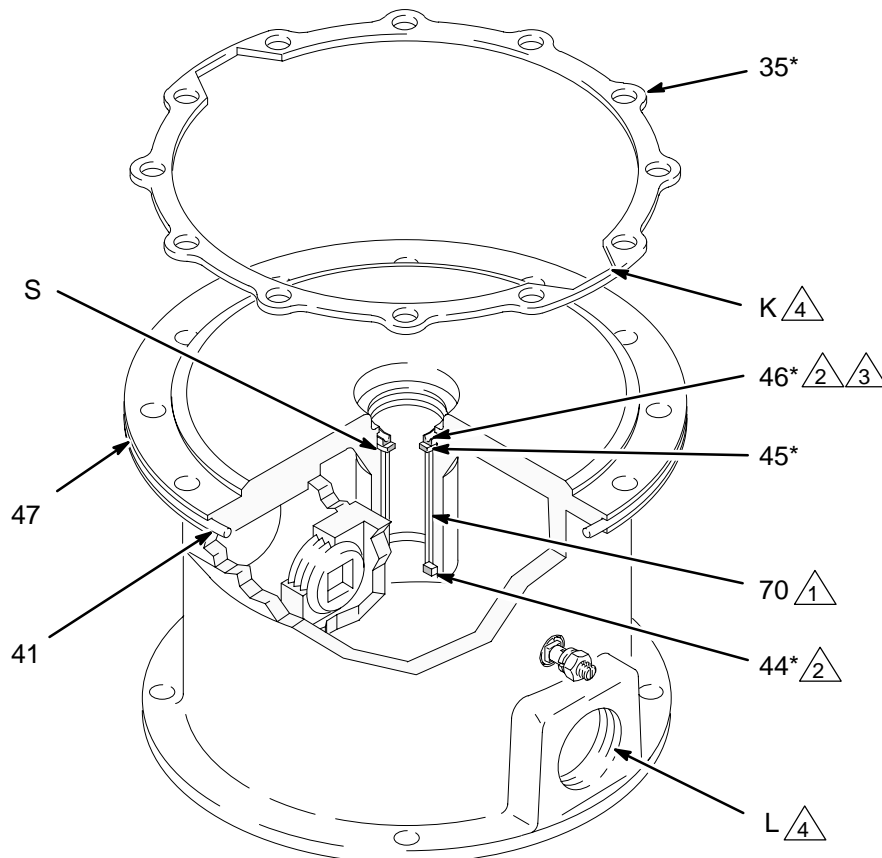

Fig. 6

07421A

Service

NOTE: Refer to Fig. 7 for steps 6 to 10.

6. Grease the trip rod (40) with light, water-proof grease and slide it into the piston (34) shaft. Clean the threads of the piston and the connecting rod stud (39). Apply Loctite® 242 or the equivalent to both. Screw the stud into the piston and torque it to 200–220 N•m (148–162 ft-lb).
7. Place the cylinder (36) upside down on the base (47). Grease the piston (34), o-ring (33*), and inside of the cylinder. Place the o-ring around the piston; the o-ring is larger than the piston groove. Install the piston in the cylinder so the excess of the o-ring fits into one of the air channels (M) of the cylinder. Use your fingers to push the o-ring out of the channel and seat it in the piston groove. Very carefully lower the piston into the cylinder.
8. Regrease the inside of the cylinder (36). Carefully turn the piston assembly and cylinder over and guide it into the base (47). Align one of the cylinder's air channels (M) with the notch (K) in the gasket (35) and with the optional fluid outlet (L) of the base. Install the lockwashers (13) and screws (31) and torque to 34 N•m (25 ft-lb).
9. Install the backup washer (64*) and v-block packing (65*) in the bearing (37) so the lips of the packing face *out* of the bearing. Install the gasket (66) on the bearing. Grease the trip rod (40) and thread the bearing onto the trip rod and into the cylinder (36). Use a 1 in. deep-well socket wrench to tighten the bearing.
10. Install the rubber pad (8) in the cylinder (36).

1 Grease with light, waterproof grease.

2 Apply Loctite® 242 or equivalent to threads.

3 Torque to 200–220 N•m (148–162 ft-lb).

4 Grease inside wall of cylinder.

5 Torque to 34 N•m (25 ft-lb).

6 Lips must face down, out of bearing (37).

7 Align air channel (M) and notch (K) in gasket (35) with the optional fluid outlet (L) in the base (47).

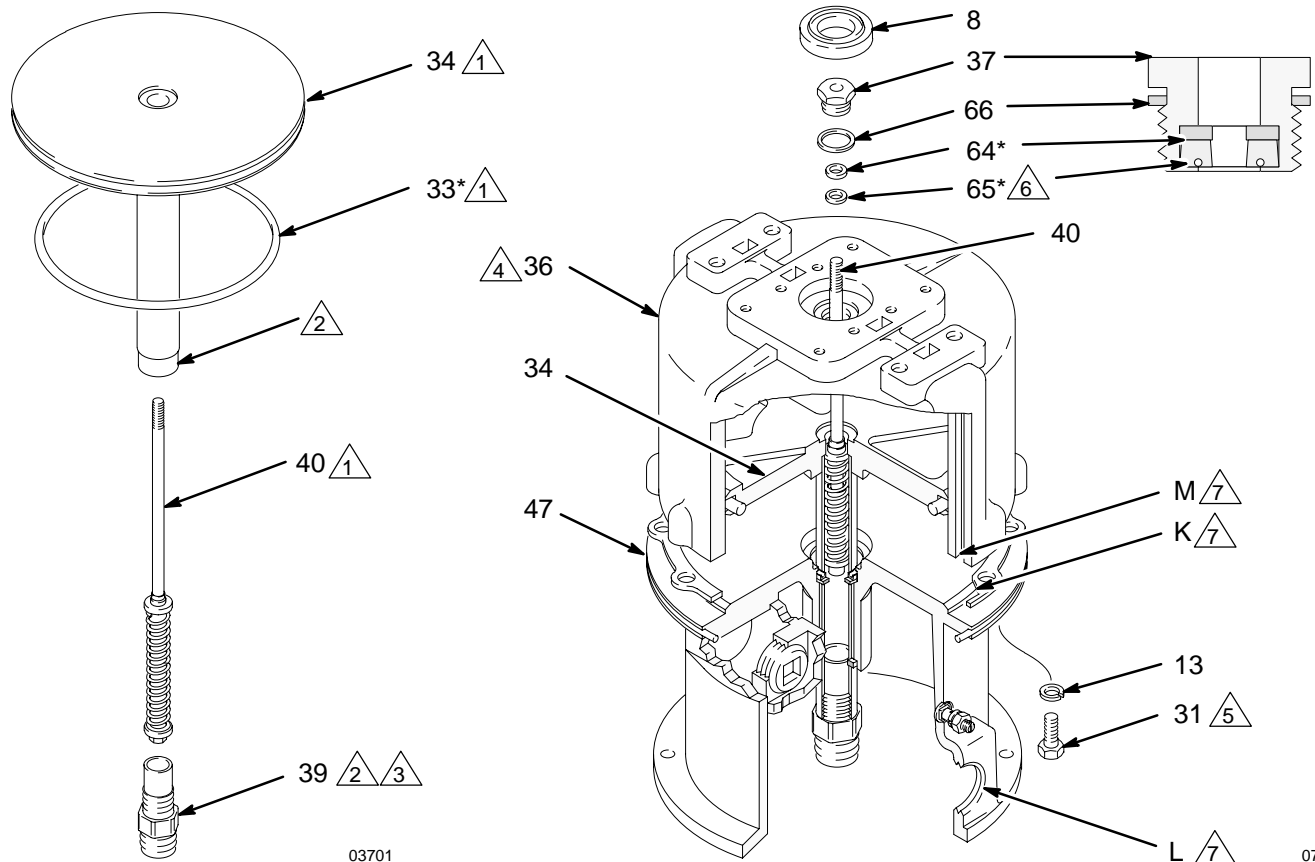

03701

07283A

Fig. 7

Service

NOTE: Refer to Fig. 8 for steps 11 to 16.

11. Place the gasket (38*) on top of the cylinder (36).
12. Thread the hub (10) onto the trip rod (40). Lift the rod and grasp it with the padded locking pliers. Screw the hub down as far as possible by hand.
13. Install the air valve housing (5), lockwasher (6), and trip rod nut (7) so the nut is flush with the top of the trip rod (40). Tighten the nut 2 turns more, so there is 1 mm (0.04 in.) clearance between the top of the rod and the top of the nut. Hold the flats of the trip rod nut with a wrench. With another wrench, tighten the hub (10) to 28–34 N•m (21–25 ft-lb). Release the pliers.
14. Place the plate seals (1) on the valve plates (2). Place the plates in the air manifold (20). Install the adjusting screw (11) and nut (12) assemblies in all four corners of the plates. **Important:** Adjust the screws and nuts evenly so they snugly hold the plates. Do not exceed 4 N•m (35 in-lb).

15. Install the rubber pad (8) in the air manifold (20).

NOTE: On Model 235525, check that the plugs (9) are in place in the air manifold exhaust ports (E).

On Model 237000, check that the tubing (82) is securely attached to the air manifold (20). See page 22.

16. Place the springs (4) and air director valves (3) into the valve housing (5). Hold the springs and valves in place and install the air manifold (20) over the housing, making sure it is properly oriented. The exhaust ports (E) must be oriented to the optional outlet (L) of the base as shown. Be sure the valve housing (5) moves up and down freely, and then install and tighten the screws (31) and lockwashers (13) holding the manifold (20) to the cylinder (36).

Detail of Air Manifold and Valve Plates

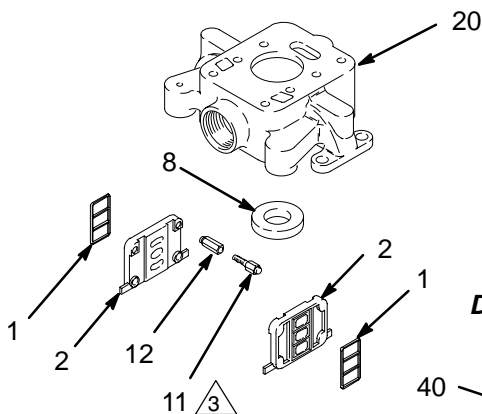

Detail of Valve Housing

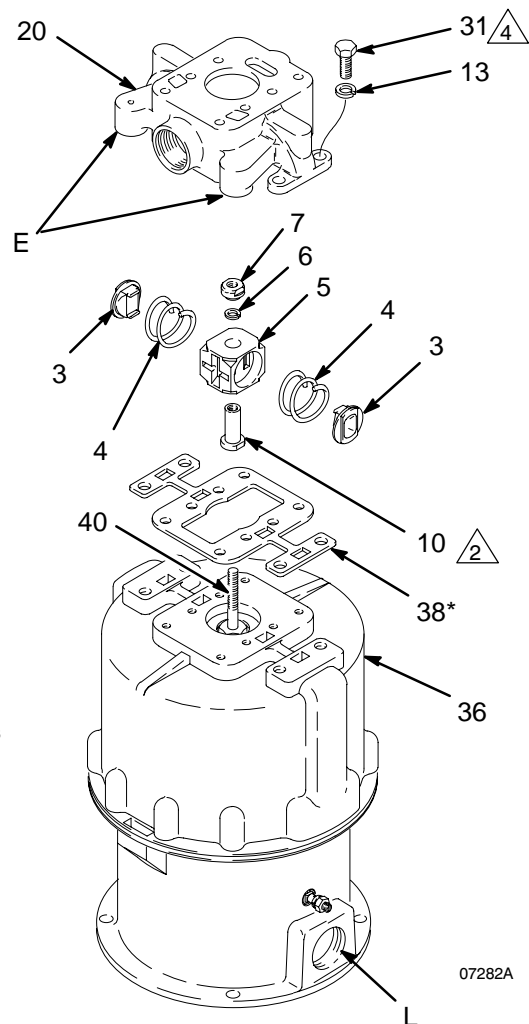
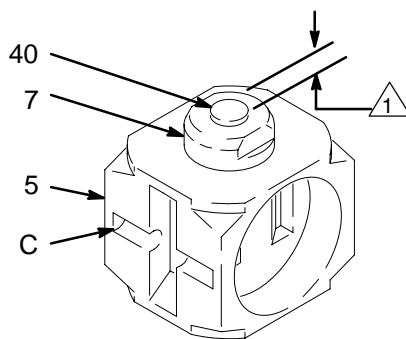

02963

07282A

1 Make top of nut flush with top of trip rod, then tighten 2 turns more. Top of nut (7) must be 1 mm (0.04") from end of rod (40).

2 Torque to 28–34 N•m (21–25 ft-lb)

3 Tighten snugly. Do not exceed 4 N•m (35 in-lb).

4 Torque to 34 N•m (25 ft-lb).

Fig. 8

Service

NOTE: Refer to Fig. 9 for steps 17 to 22.

17. Lubricate the housing (18), spring (17), and guide (16) with light, water-proof grease. Assemble the housing and spring into the guide. Lubricate the pin (19) and slide it into the housing. Slide these assembled parts into the air manifold (20). Be sure the pin (19) is aligned with the slot (C, Fig. 8) of the air valve housing (5) before assembling the rest of the air valve. Repeat for the other side.
18. Install the o-ring (15) on the retainer (14). Screw the retainers into both sides of the manifold (20); they should readily screw all the way into the manifold by hand. If they do not, the parts are not assembled correctly; inspect, and correct any misalignment. Now firmly tighten the retainers (14).
19. Place the gasket (30*), cap (29), and gasket (53) on the air manifold (20). Check the parts list for your model for the correct gasket (30*) to use. Be sure these parts are oriented as shown in the parts drawing for your model.

⚠ WARNING



MOVING PARTS HAZARD
Do not operate without the air motor shield in place. Pinching or amputation of fingers or hands may occur. See **MOVING PARTS HAZARD** on page 3.

20. To install the shield (27), perform step a or b, as applicable.
 - a. *For Models 220106 and 235525:* Install the o-ring (26), lift ring (25), screws (24), lock-washers (23), air inlet assembly, and shield (27). Torque the screws to 12–16 N•m (9–12 ft-lb).
 - b. *For Model 237000:* See page 22. Thread the tube (83) through the grommet (81) in the shield (27) as much as possible. Install the shield. Install the o-ring (26), lift ring (25), screws (24), lockwashers (23), air inlet fitting (68), and mufflers (76). Torque the screws to 12–16 N•m (9–12 ft-lb). Connect the tube (83) to the fitting (87).
21. Test the motor at 0.1–0.2 MPa, 1–2 bar (15–30 psi) before reconnecting to the pump, to be sure it operates properly.

22. Reconnect the motor to the displacement pump, remount the pump and connect the air and fluid lines. Reconnect the ground wire before operating the pump.

- 1 Grease with light, waterproof grease.
- 2 Torque to 12–16 N•m (9–12 ft-lb).

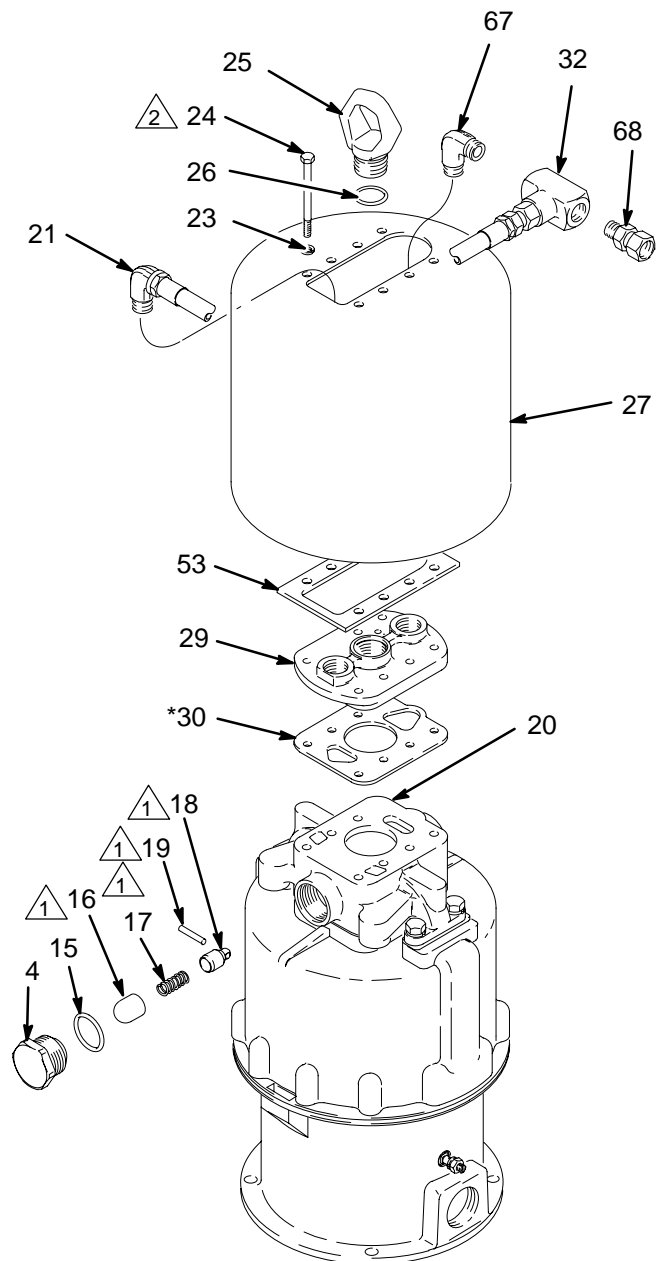

Model 220106 Shown

07281A

Fig. 9

Parts

Model 220106, Series A
Standard Quiet Air Motor

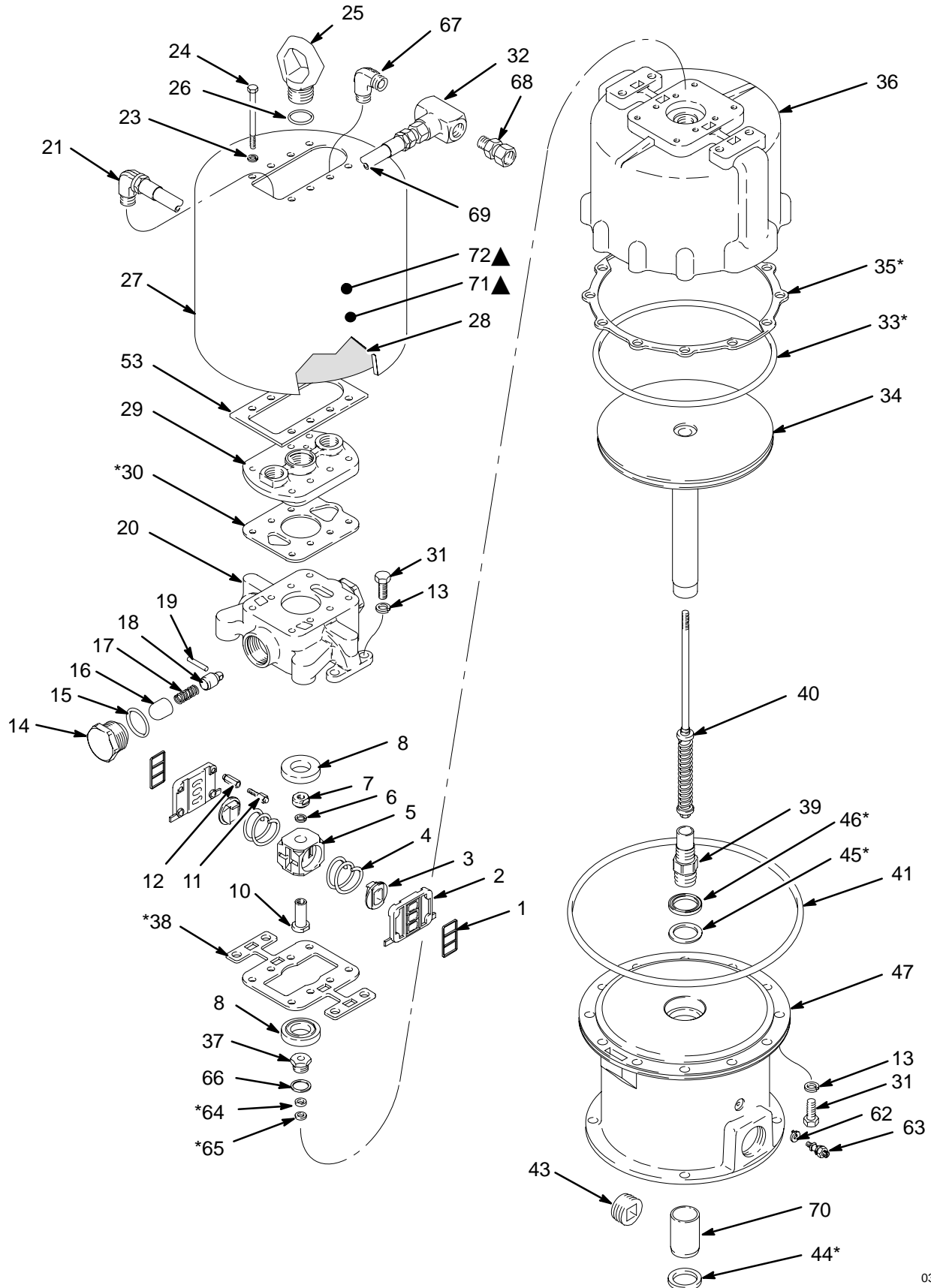

Parts

Model 220106, Series A Standard Quiet Air Motor

Ref No.	Part No.	Description	Qty	Ref No.	Part No.	Description	Qty
1	168184	SEAL, plate	2	37✓	215933	BEARING, trip rod	1
2	176536	PLATE, valve	2	38*	176575	GASKET; cellulose fibre	1
3✓	176518	VALVE, director	2	39	176564	STUD, connecting rod	1
4	176543	SPRING, compression	2	40✓	218597	TRIP ROD ASSY	1
5✓	176519	HOUSING, air valve	1	41✓	102737	O-RING; buna-N	1
6	105319	LOCKWASHER; 10 mm	1	43	102725	PLUG, pipe	1
7	176569	NUT, trip rod	1	44*	161569	SEAL, wiper	1
8✓	176549	PAD, rubber	2	45*	161563	WASHER, backup	1
10	176568	HUB, valve housing	1	46*	161562	V-PACKING; nitrile rubber	1
11	176550	SCREW, adjusting	4	47	235844	AIR MOTOR BASE ASSY	
12	176548	NUT, adjusting	4			includes item 70	1
13	100018	LOCKWASHER	4	53✓	177081	GASKET; neoprene	1
14	178428	RETAINER, toggle	2	62	104582	WASHER, tab	1
15✓	105318	O-RING; nitrile rubber	2	63	104029	CLAMP, grounding	1
16✓	178427	GUIDE, housing	2	64*	161559	WASHER, backup	1
17✓	178429	SPRING, compression	2	65*	161560	V-PACKING; polyurethane	1
18✓	178426	HOUSING, spring	2	66✓	150647	GASKET; copper	1
19✓	105321	PIN, dowel	2	67	108307	ELBOW, pipe, 90°; 3/4 npt(mbe)	1
20	181322	MANIFOLD, air	1	68	157785	UNION, swivel; 3/4 nps(f) swivel x 3/4 npt(m)	2
21	100549	ELBOW, pipe, 90° street; 3/4 npt (m x f)	1	69	214953	HOSE, air; buna-N; 3/4" ID; cpld 3/4 npt(mbe); 1.25' (381 mm)	1
23	104572	LOCKWASHER; 8 mm	8	70	189059	BEARING	1
24	105322	CAPSCREW, hex hd; M8 x 1.5 x 100	8	71▲	290331	LABEL, warning; English	1
25	176537	RING, lift	1	72▲	189991	LABEL, warning	1
26✓	166221	O-RING; nitrile rubber	1				
27	181276	SHIELD	1				
28	181308	INSULATION	2				
29	181321	CAP, manifold	1				
30*	181323	GASKET; cellulose fibre	1				
31	105324	CAPSCREW, hex hd; M12 x 1.75 x 30	16				
32	166466	TEE, pipe; 3/4 npt(f)	1				
33*	102727	O-RING; nitrile rubber	1				
34	220105	PISTON ASSEMBLY	1				
35*	168189	GASKET; buna-N/cellulose	1				
36	181297	CYLINDER	1				

* These parts are included in Repair Kit 220153, which may be purchased separately.

✓ Keep these spare parts on hand to reduce down time.

▲ Replacement Danger and Warning labels, tags and cards are available at no cost. The 290331 label is also available in the following languages:
German (Part No. 290396)
French (Part No. 290397)
Spanish (Part No. 290398).

Parts

Model 235525, Series B Quiet Air Motor

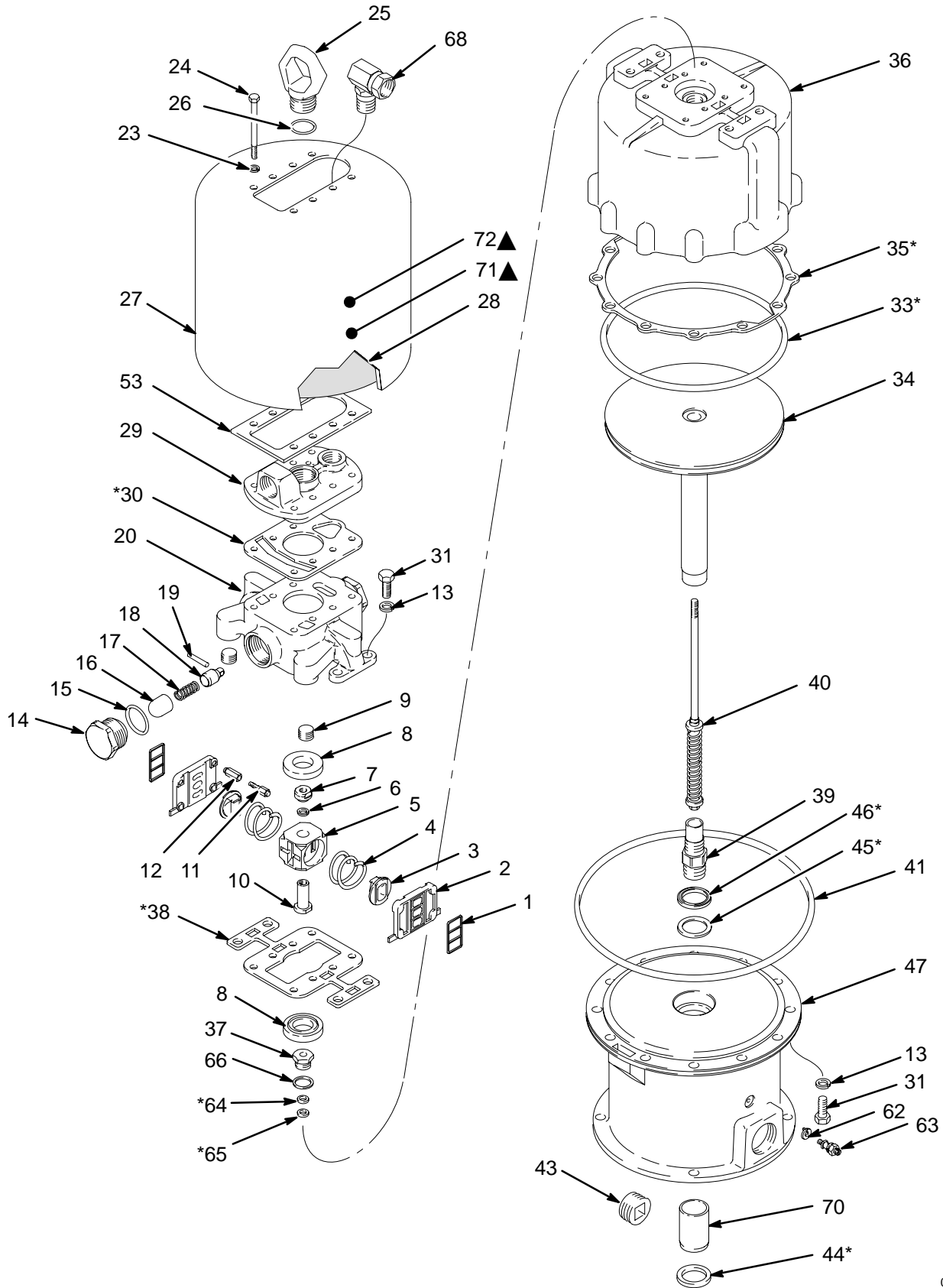

Parts

Model 235525, Series B

Quiet Air Motor

Ref No.	Part No.	Description	Qty	Ref No.	Part No.	Description	Qty
1	168184	SEAL, plate	2	37✓	215933	BEARING, trip rod	1
2	176536	PLATE, valve	2	38*	176575	GASKET; cellulose fibre	1
3✓	176518	VALVE, director	2	39	176564	STUD, connecting rod	1
4	176543	SPRING, compression	2	40✓	218597	TRIP ROD ASSY	1
5✓	176519	HOUSING, air valve	1	41✓	102737	O-RING; buna-N	1
6	105319	LOCKWASHER; 10 mm	1	43	102725	PLUG, pipe	1
7	176569	NUT, trip rod	1	44*	161569	SEAL, wiper	1
8✓	176549	PAD, rubber	2	45*	161563	WASHER, backup	1
9	100361	PLUG, pipe	2	46*	161562	V-PACKING; nitrile rubber	1
10	176568	HUB, valve housing	1	47	235844	AIR MOTOR BASE ASSY	
11	176550	SCREW, adjusting	4			includes item 70	1
12	176548	NUT, adjusting	4	53✓	177081	GASKET; neoprene	1
13	100018	LOCKWASHER	4	62	104582	WASHER, tab	1
14	178428	RETAINER, toggle	2	63	104029	CLAMP, grounding	1
15✓	105318	O-RING; nitrile rubber	2	64*	161559	WASHER, backup	1
16✓	178427	GUIDE, housing	2	65*	161560	V-PACKING; polyurethane	1
17✓	178429	SPRING, compression	2	66✓	150647	GASKET; copper	1
18✓	178426	HOUSING, spring	2	68	207648	ADAPTER, swivel; 3/4 npt(m) x 3/4 npsm(f)	1
19✓	105321	PIN, dowel	2				
20	176540	MANIFOLD, air	1	70	189059	BEARING	1
23	104572	LOCKWASHER; 8 mm	8	71▲	290331	LABEL, warning; English	1
24	105322	CAPSCREW, hex hd; M8 x 1.5 x 100	8	72▲	189991	LABEL, warning	1
25	176537	RING, lift	1				
26✓	166221	O-RING; nitrile rubber	1				
27	181276	SHIELD	1				
28	181308	INSULATION	2				
29	176539	CAP, manifold	1				
30*	176580	GASKET; cellulose fibre	1				
31	105324	CAPSCREW, hex hd; M12 x 1.75 x 30	16				
33*	102727	O-RING; nitrile rubber	1				
34	220105	PISTON ASSEMBLY	1				
35*	168189	GASKET; buna-N/cellulose	1				
36	181297	CYLINDER	1				

* These parts are included in Repair Kit 220153, which may be purchased separately.

✓ Keep these spare parts on hand to reduce down time.

▲ Replacement Danger and Warning labels, tags and cards are available at no cost. The 290331 label is also available in the following languages:
 German (Part No. 290396)
 French (Part No. 290397)
 Spanish (Part No. 290398).

Parts

Model 237000, Series A Reduced Icing Quiet Air Motor

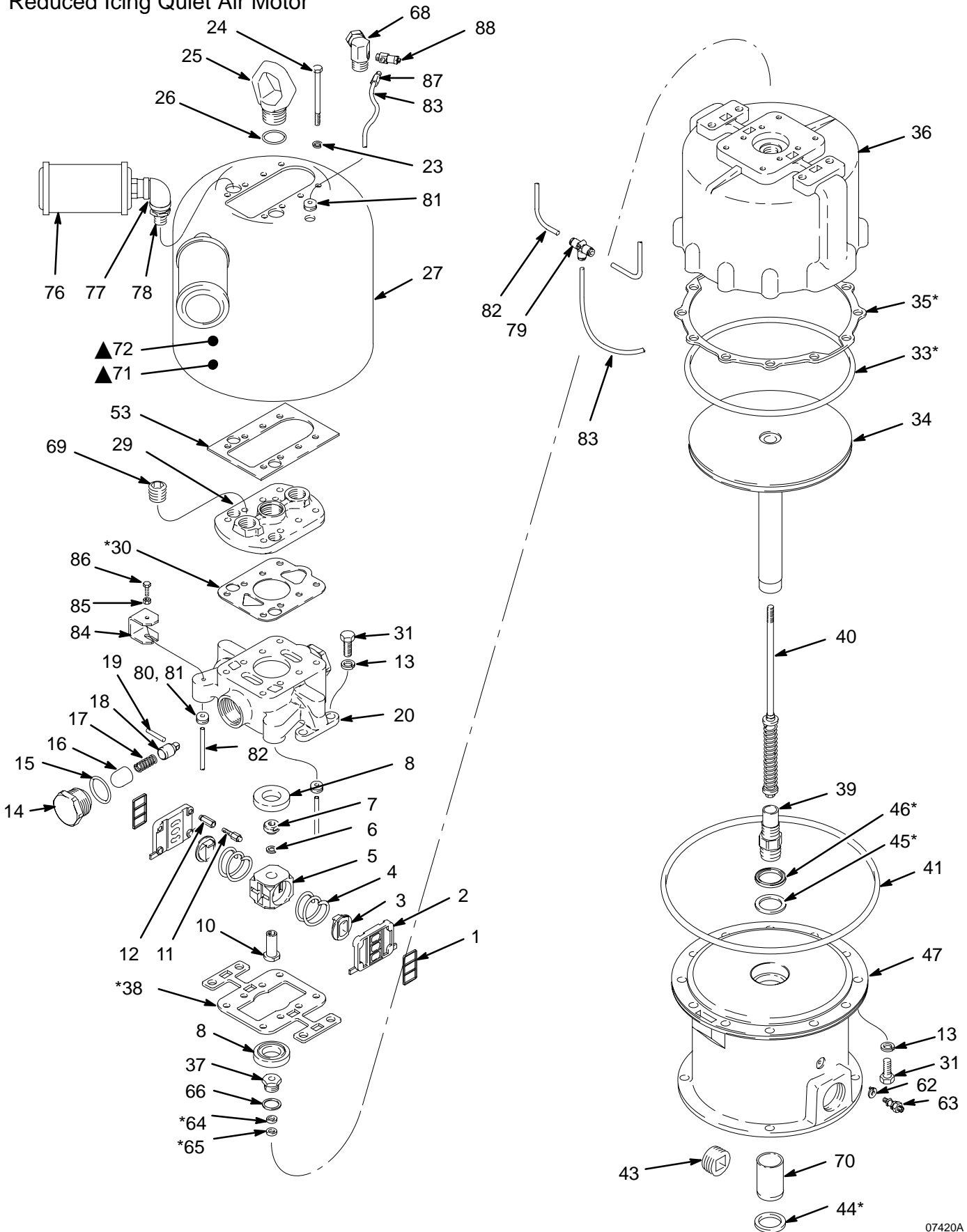

Parts

Model 237000, Series A Reduced Icing Quiet Air Motor

Ref No.	Part No.	Description	Qty	Ref No.	Part No.	Description	Qty
1	168184	SEAL, plate	2	47	235844	AIR MOTOR BASE ASSY	
2	176536	PLATE, valve	2			includes item 70	1
3✓	176518	VALVE, director	2	53✓	112740	GASKET; neoprene	1
4	176543	SPRING, compression	2	62	104582	WASHER, tab	1
5✓	176519	HOUSING, air valve	1	63	104029	CLAMP, grounding	1
6	105319	LOCKWASHER; 10 mm	1	64*	161559	WASHER, backup	1
7	176569	NUT, trip rod	1	65*	161560	V-PACKING; polyurethane	1
8✓	176549	PAD, rubber	2	66✓	150647	GASKET; copper	1
10	176568	HUB, valve housing	1	68	189986	AIR INLET FITTING; 3/4 npt(m) x 3/4 npt(f) swivel x 1/8 npt(f)	1
11	176550	SCREW, adjusting	4	69	102726	PLUG, pipe; 1" npt	1
12	176548	NUT, adjusting	4	70	189059	BEARING	1
13	100018	LOCKWASHER	4	71▲	290331	LABEL, warning; English	1
14	178428	RETAINER, toggle	2	72▲	189991	LABEL, warning	1
15✓	105318	O-RING; nitrile rubber	2	76	111897	MUFFLER	2
16✓	178427	GUIDE, housing	2	77	112885	ELBOW; 1" x 1/2 npt (fbe)	2
17✓	178429	SPRING, compression	2	78	801523	ADAPTER; 1/2 npt x 1/2 btp (mbe)	2
18✓	178426	HOUSING, spring	2	79	112739	TEE; 1/4" (6 mm) OD tube	1
19✓	105321	PIN, dowel	2	80	109018	O-RING; nitrile	2
20	181322	MANIFOLD, air	1	81	112738	GROMMET	3
23	104572	LOCKWASHER; 8 mm	8	82	190009	TUBE; nylon; 1/4" (6 mm) OD; 8" (203 mm) long	2
24	105322	CAPSCREW, hex hd; M8 x 1.5 x 100	8	83	190010	TUBE; nylon; 1/4" (6 mm) OD; 21" (533 mm) long	1
25	176537	RING, lift	1	84	112735	BRACKET	2
26✓	166221	O-RING; nitrile rubber	1	85	105912	NUT, hex; M6 x 1	2
27	112736	SHIELD	1	86	112117	SCREW, cap, hex hd; M6 x 1.0; 16 mm (5/8") long	2
29	189985	CAP, manifold	1	87	104172	FITTING, tube; 1/8 npt(m)	1
30*	112741	GASKET; cellulose fibre	1	88	203743	VALVE, needle	1
31	105324	CAPSCREW, hex hd; M12 x 1.75 x 30	16				
33*	102727	O-RING; nitrile rubber	1				
34	220105	PISTON ASSEMBLY	1				
35*	168189	GASKET; buna-N/cellulose	1				
36	181297	CYLINDER	1				
37✓	215933	BEARING, trip rod	1				
38*	176575	GASKET; cellulose fibre	1				
39	176564	STUD, connecting rod	1				
40✓	218597	TRIP ROD ASSY	1				
41✓	102737	O-RING; buna-N	1				
43	102725	PLUG, pipe	1				
44*	161569	SEAL, wiper	1				
45*	161563	WASHER, backup	1				
46*	161562	V-PACKING; nitrile rubber	1				

* These parts are included in Repair Kit 220153, which may be purchased separately.

✓ Keep these spare parts on hand to reduce down time.

▲ Replacement Danger and Warning labels, tags and cards are available at no cost. The 290331 label is also available in the following languages:
German (Part No. 290396)
French (Part No. 290397)
Spanish (Part No. 290398).

Dimensions

Models 220106 (shown) and 235525

3/4 npt(f) Swivel
Air Inlet

Model 237000

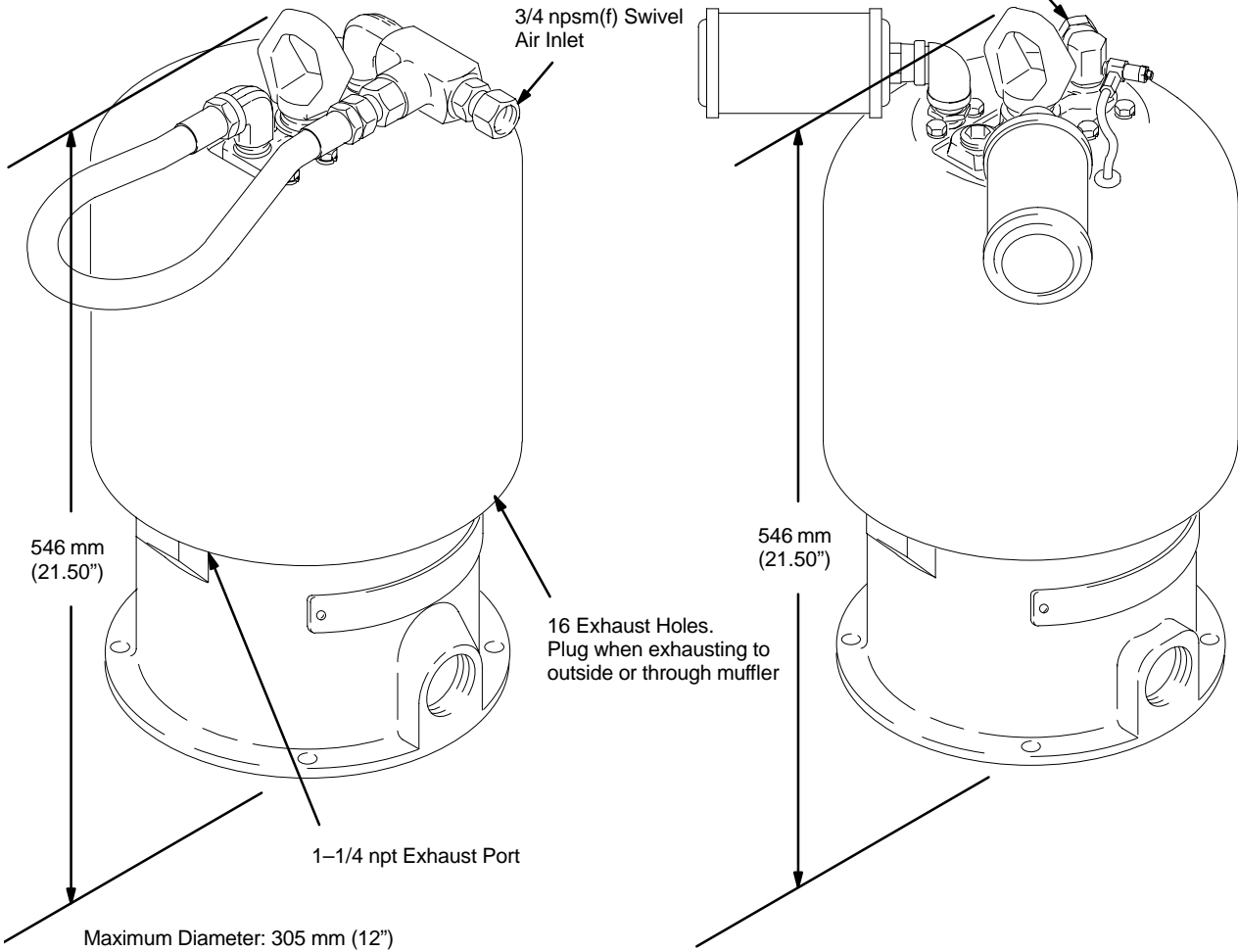

03695

03697

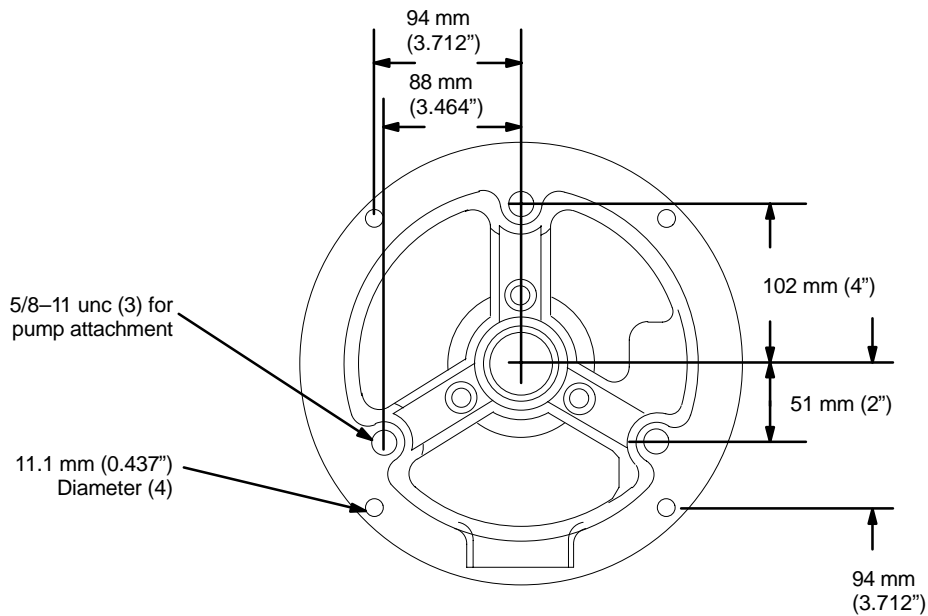

BOTTOM VIEW

03702

Technical Data

Category	Data
Maximum Incoming Air Pressure	0.6 MPa, 6.2 bar (90 psi)
Effective Piston Area	506 cm ² (78.5 sq. in.)
Piston Diameter	255 mm (10 in.)
Stroke Length	121 mm (4.75 in.)
Air Valves	stainless steel plate; sliding acetal ring
Recommended maximum speed	50 cycles per minute
Weight	34 kg (75 lb)
Air inlet	3/4 npsm

Loctite® is a registered trademark of the Loctite Corporation.

Manual Change Summary

Correction to Model 237000: Part number 190010 (83) was 109010.

The Graco Standard Warranty

Graco warrants all equipment manufactured by Graco and bearing its name to be free from defects in material and workmanship on the date of sale by an authorized Graco distributor to the original purchaser for use. With the exception of any special, extended, or limited warranty published by Graco, Graco will, for a period of twelve months from the date of sale, repair or replace any part of the equipment determined by Graco to be defective. This warranty applies only when the equipment is installed, operated and maintained in accordance with Graco's written recommendations.

This warranty does not cover, and Graco shall not be liable for general wear and tear, or any malfunction, damage or wear caused by faulty installation, misapplication, abrasion, corrosion, inadequate or improper maintenance, negligence, accident, tampering, or substitution of non-Graco component parts. Nor shall Graco be liable for malfunction, damage or wear caused by the incompatibility of Graco equipment with structures, accessories, equipment or materials not supplied by Graco, or the improper design, manufacture, installation, operation or maintenance of structures, accessories, equipment or materials not supplied by Graco.

This warranty is conditioned upon the prepaid return of the equipment claimed to be defective to an authorized Graco distributor for verification of the claimed defect. If the claimed defect is verified, Graco will repair or replace free of charge any defective parts. The equipment will be returned to the original purchaser transportation prepaid. If inspection of the equipment does not disclose any defect in material or workmanship, repairs will be made at a reasonable charge, which charges may include the costs of parts, labor, and transportation.

THIS WARRANTY IS EXCLUSIVE, AND IS IN LIEU OF ANY OTHER WARRANTIES, EXPRESS OR IMPLIED, INCLUDING BUT NOT LIMITED TO WARRANTY OF MERCHANTABILITY OR WARRANTY OF FITNESS FOR A PARTICULAR PURPOSE.

Graco's sole obligation and buyer's sole remedy for any breach of warranty shall be as set forth above. The buyer agrees that no other remedy (including, but not limited to, incidental or consequential damages for lost profits, lost sales, injury to person or property, or any other incidental or consequential loss) shall be available. Any action for breach of warranty must be brought within two (2) years of the date of sale.

Graco makes no warranty, and disclaims all implied warranties of merchantability and fitness for a particular purpose in connection with accessories, equipment, materials or components sold but not manufactured by Graco. These items sold, but not manufactured by Graco (such as electric motors, switches, hose, etc.), are subject to the warranty, if any, of their manufacturer. Graco will provide purchaser with reasonable assistance in making any claim for breach of these warranties.

In no event will Graco be liable for indirect, incidental, special or consequential damages resulting from Graco supplying equipment hereunder, or the furnishing, performance, or use of any products or other goods sold hereto, whether due to a breach of contract, breach of warranty, the negligence of Graco, or otherwise.

FOR GRACO CANADA CUSTOMERS

The parties acknowledge that they have required that the present document, as well as all documents, notices and legal proceedings entered into, given or instituted pursuant hereto or relating directly or indirectly hereto, be drawn up in English. Les parties reconnaissent avoir convenu que la rédaction du présente document sera en Anglais, ainsi que tous documents, avis et procédures judiciaires exécutés, donnés ou intentés à la suite de ou en rapport, directement ou indirectement, avec les procédures concernées.

Graco Phone Number

TO PLACE AN ORDER, contact your Graco distributor, or call this number to identify the distributor closest to you:
1-800-367-4023 Toll Free.

*All written and visual data contained in this document reflects the latest product information available at the time of publication.
Graco reserves the right to make changes at any time without notice.*

Sales Offices: Minneapolis, Detroit

Foreign Offices: Belgium, Korea, Hong Kong, Japan

GRACO INC. P.O. BOX 1441 MINNEAPOLIS, MN 55440-1441

www.graco.com

PRINTED IN USA 307741 July 1985, Revised November 1999

Free Manuals Download Website

<http://myh66.com>

<http://usermanuals.us>

<http://www.somanuals.com>

<http://www.4manuals.cc>

<http://www.manual-lib.com>

<http://www.404manual.com>

<http://www.luxmanual.com>

<http://aubethermostatmanual.com>

Golf course search by state

<http://golfingnear.com>

Email search by domain

<http://emailbydomain.com>

Auto manuals search

<http://auto.somanuals.com>

TV manuals search

<http://tv.somanuals.com>