

# Mini Fire-Ball<sup>®</sup> 225, 50:1 Grease Pump Packages

309967C  
EN

## Portable units for dispensing heavy grease.

See page 2 for model numbers.

*5000 psi (34 MPa, 345 bar) Maximum Working Pressure*  
*100 psi (0.7 MPa, 7 bar) Maximum Air Working Pressure*



**Important Safety Instructions**  
Read all warnings and instructions in this manual.  
Save these instructions.

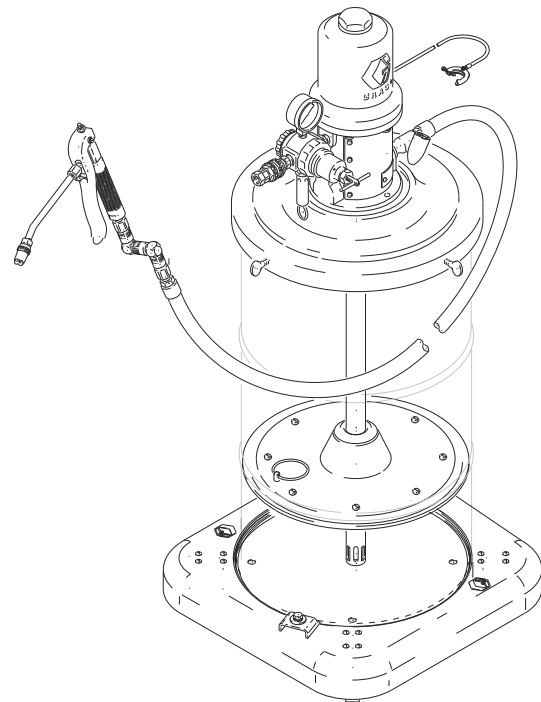

Model 253388 shown



PROVEN QUALITY. LEADING TECHNOLOGY.





# Models





Model No.	Size	Dispense Kit 236058	Hose/Fitting Kit 222072	Base Type	Cover	Follow Plate	Handle	Pail	CE Kit 240979
246910	35-50 lb (16-23 kg)	✓			222059	24F901	✓		
253384†	35-50 lb (16-23 kg)	✓			222059	220653	✓		✓
253362	35-50 lb (16-23 kg)	✓			222059	24F901			
246911	35-50 lb (16-23 kg)	✓			24R350		✓	✓	
253385†	35-50 lb (16-23 kg)	✓			204574		✓	✓	✓
246913	35-50 lb (16-23 kg)	✓		2-wheel truck	24R350		✓	✓	
253386†	35-50 lb (16-23 kg)	✓		2-wheel truck	204574		✓	✓	✓
246914	120 lb (55 kg)		✓		24R350	24F902			
253387†	120 lb (55 kg)		✓		204574	220654			✓
246915	120 lb (55 kg)	✓		portable	24R350	24F902			
253388†	120 lb (55 kg)	✓		portable	204574	220654			✓
246916	120 lb (55 kg)	✓		2-wheel truck	24R350	24F902			
253389†	120 lb (55 kg)	✓		2-wheel truck	204574	220654			✓
246917	400 lb (180 kg)		✓		200326	24F903			
253390†	400 lb (180 kg)		✓		200326	223845			✓

† These models are CE certified.

# Warnings

The following general warnings are for the setup, use, grounding, maintenance, and repair of this equipment. Additional, more specific warnings may be found throughout the body of this manual where applicable. *Symbols appearing in the body of the manual refer to these general warnings. When these symbols appear throughout the manual, refer back to these pages for a description of the specific hazard.*

 <b>WARNING</b>	
	<p><b>EQUIPMENT MISUSE HAZARD</b></p> <p>Misuse can cause death or serious injury.</p> <ul style="list-style-type: none"> <li>• Do not operate the unit when fatigued or under the influence of drugs or alcohol.</li> <li>• Do not exceed the maximum working pressure or temperature rating of the lowest rated system component. See <b>Technical Data</b> in all equipment manuals.</li> <li>• Use fluids and solvents that are compatible with equipment wetted parts. See <b>Technical Data</b> in all equipment manuals. Read fluid and solvent manufacturer's warnings. For complete information about your material, request MSDS forms from distributor or retailer.</li> <li>• Check equipment daily. Repair or replace worn or damaged parts immediately with genuine Graco replacement parts only.</li> <li>• Do not alter or modify equipment.</li> <li>• Use equipment only for its intended purpose. Call your Graco distributor for information.</li> <li>• Route hoses and cables away from traffic areas, sharp edges, moving parts, and hot surfaces.</li> <li>• Do not kink or over bend hoses or use hoses to pull equipment.</li> <li>• Keep children and animals away from work area.</li> <li>• Comply with all applicable safety regulations.</li> </ul>
	<p><b>SKIN INJECTION HAZARD</b></p> <p>High-pressure fluid from dispense valve, hose leaks, or ruptured components will pierce skin. This may look like just a cut, but it is a serious injury that can result in amputation. <b>Get immediate surgical treatment.</b></p> <ul style="list-style-type: none"> <li>• Do not point dispense valve at anyone or at any part of the body.</li> <li>• Do not put your hand over the end of the dispense nozzle.</li> <li>• Do not stop or deflect leaks with your hand, body, glove, or rag.</li> <li>• Follow <b>Pressure Relief Procedure</b> in this manual, when you stop dispensing and before cleaning, checking, or servicing equipment.</li> </ul>
	<p><b>MOVING PARTS HAZARD</b></p> <p>Moving parts can pinch or amputate fingers and other body parts.</p> <ul style="list-style-type: none"> <li>• Keep clear of moving parts.</li> <li>• Do not operate equipment with protective guards or covers removed.</li> <li>• Pressurized equipment can start without warning. Before checking, moving, or servicing equipment, follow the <b>Pressure Relief Procedure</b> in this manual. Disconnect power or air supply.</li> </ul>

 <b>WARNING</b>	
	<p><b>FIRE AND EXPLOSION HAZARD</b></p> <p>When flammable fluids are present in the work area, such as gasoline and windshield wiper fluid, be aware that flammable fumes can ignite or explode. To help prevent fire and explosion:</p> <ul style="list-style-type: none"> <li>• Use equipment only in well ventilated area.</li> <li>• Eliminate all ignition sources, such as cigarettes and portable electric lamps.</li> <li>• Keep work area free of debris, including rags and spilled or open containers of solvent and gasoline.</li> <li>• Do not plug or unplug power cords or turn lights on or off when flammable fumes are present.</li> <li>• Ground all equipment in the work area.</li> <li>• Use only grounded hoses.</li> <li>• If there is static sparking or you feel a shock, <b>stop operation immediately</b>. Do not use equipment until you identify and correct the problem.</li> <li>• Keep a working fire extinguisher in the work area.</li> </ul>
	<p><b>TOXIC FLUID OR FUMES HAZARD</b></p> <p>Toxic fluids or fumes can cause serious injury or death if splashed in the eyes or on skin, inhaled, or swallowed.</p> <ul style="list-style-type: none"> <li>• Read SDS's to know the specific hazards of the fluids you are using.</li> <li>• Store hazardous fluid in approved containers, and dispose of it according to applicable guidelines.</li> </ul>
	<p><b>PERSONAL PROTECTIVE EQUIPMENT</b></p> <p>You must wear appropriate protective equipment when operating, servicing, or when in the operating area of the equipment to help protect you from serious injury, including eye injury, inhalation of toxic fumes, burns, and hearing loss. This equipment includes but is not limited to:</p> <ul style="list-style-type: none"> <li>• Protective eyewear</li> <li>• Clothing and respirator as recommended by the fluid and solvent manufacturer</li> <li>• Gloves</li> <li>• Hearing protection</li> </ul>

## Operation/Service

Refer to pump manual 309966 (supplied) for operating and service instructions.

# Installation

## General Information



**NOTE:** Reference numbers and letters in parentheses in the text refer to the callouts in the figures and parts drawing.

**NOTE:** Always use genuine Graco parts and accessories, available from your Graco distributor.

### Air Line Accessories

See page 6 for recommended air accessories and installation.

## Grounding

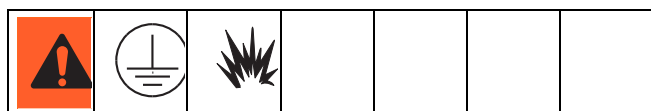

To reduce the risk of static sparking, ground the pump and all other components used or located in the dispensing area. Check your local electrical code for detailed instructions for your area and type of equipment.

### Ground this equipment:

**Pump:** remove the ground screw (Z) and insert through the eye of the ring terminal at end of ground wire (Y). Fasten the ground screw back onto the pump and tighten securely. Connect the other end of the ground wire to a true earth ground. See FIG. 1. *To order a ground wire and clamp, order Part No. 222011.*

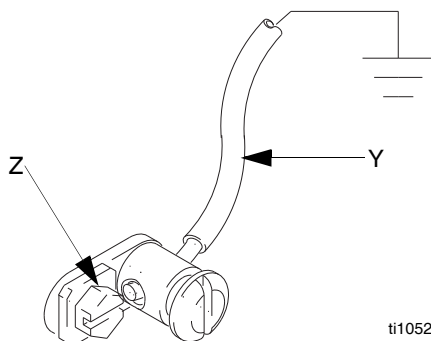

FIG. 1

**Air and fluid hoses:** use only grounded hoses.

**Air compressor:** follow manufacturer's recommendations.

**Dispense valve:** ground through connection to a properly grounded fluid hose and pump.

**Fluid supply container:** follow local code.

**To maintain grounding continuity when flushing or relieving pressure:** hold metal part of the dispense valve firmly to the side of a grounded metal pail, then trigger the valve.

## Typical Installation

The installation shown below is only a guide for selecting and installing system components and accessories. Contact your Graco distributor for assistance in designing a system to suit your particular needs.

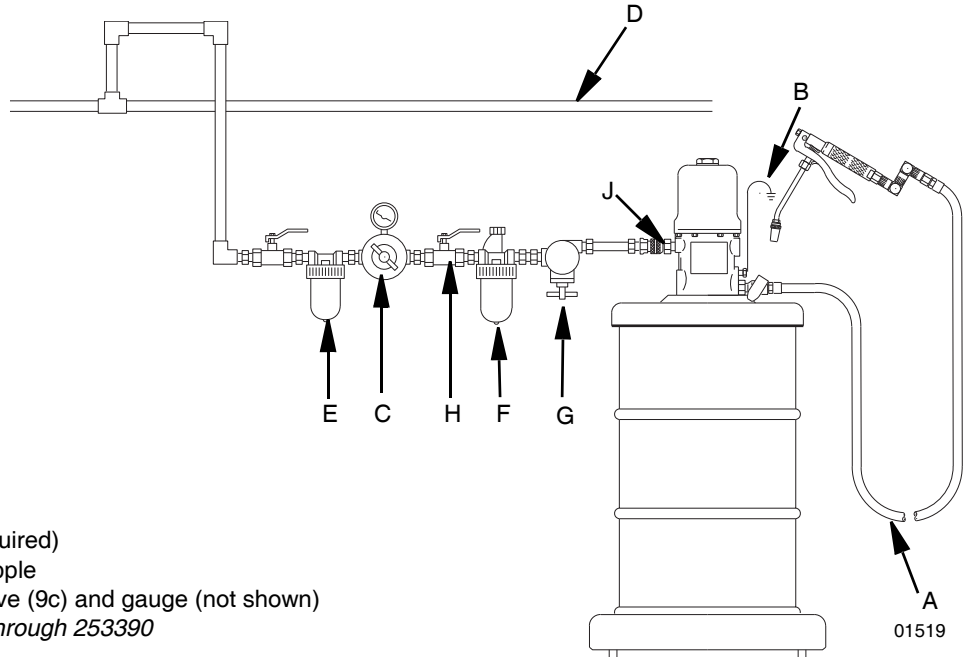

### Key:

- A Fluid dispense line
- B Pump ground wire (required)
- C Air regulator
- D Main air supply line
- E Air filter
- F Pump lubricator
- G Pump runaway valve
- H Bleed-type master air valve (required)
- J Quick-disconnect couple and nipple
- K Air regulator (9b) with safety valve (9c) and gauge (not shown)  
*Included with models 253384 through 253390*

## Air Line and Accessories

**NOTE:** Install air line accessories in the order shown in the Typical Installation illustration.



<p>Trapped air can cause the air motor to cycle unexpectedly, causing serious injury if you are adjusting or repairing the pump. Be sure to follow the <b>Pressure Relief Procedure</b> on page 11.</p>						

- Install a pump runaway valve (G) to shut off the air to the pump if the pump accelerates beyond the pre-adjusted setting. A pump that runs too fast can be seriously damaged.
- Install an air line lubricator (F) for automatic air motor lubrication.
- Install a bleed-type master air valve (H) to relieve air trapped between the valve and the motor when the valve is closed.

- Install the air regulator (C) to control pump speed and pressure.
- On the main air supply line from the compressor, install an air line filter (E) to remove harmful dirt and contaminants from the compressed air supply.
- For models 253384 through 253390, install the provided air regulator/safety valve (K) at the pump air inlet with the nipple (9a, also included).

Avoid hanging air accessories directly on the pump air inlet. The fittings are not strong enough to support the accessories and may cause one or more to break. If accessories must be installed directly on the pump, provide a bracket on which to mount them.

**Models 246910, 253362, and 253384 (FIG. 2)**

1. Remove the cover from the pail, and scoop the lubricant from the center to the sides of the pail to make its surface concave.
2. Center the follow plate (5) in the pail opening. Press the plate firmly downward and rotate it over the lubricant surface to eliminate air pockets and prevent channeling.
3. Insert the pump through the cover (4a) and slide the cover up far enough to let the pump pass easily through the follow plate grommet. The pump stop plate(4b) will secure the pump in place.
4. Place the cover (4a) on the pail, and tighten the thumbscrews (4f).
5. Assemble the gun (2b) and hose (2a), and connect the hose to the pump fluid outlet.
6. Connect the nipple (2d) to the pump air inlet or air regulator (9b) inlet, whichever is applicable. Connect the quick-disconnect coupler (2c) to the air supply hose.

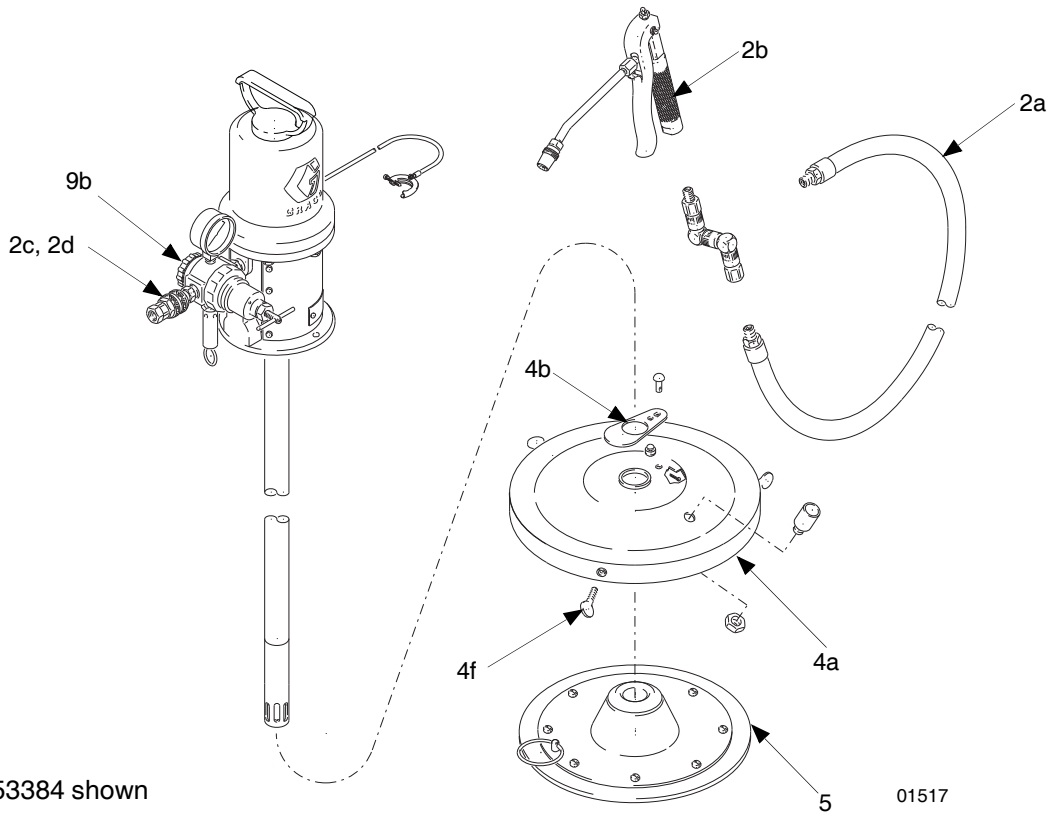

Model 253384 shown

01517

**FIG. 2**

**Models 246911, 246913, 253385 and 253386 (FIG. 3)**

1. Remove the fluid outlet adapter included with the pump, and screw the holster (6) into the pump outlet using thread sealant.
2. *Models 246913 and 253386:* Assemble the truck (7) as shown in the parts drawing on page 13. Secure the truck pail (10) to the truck base with the pointed clamps (7d) and thumbnuts (7c).
3. Remove the cover from the pail of lubricant. Place the pail of lubricant into the truck pail.
4. Secure the cover (4) on the pail with the three thumbscrews (A).
5. Install shim (11) on top of drum. Align holes in shim with holes in cover (4).
6. Insert the pump riser tube through the top of the shim (11) and cover (4). Lower the pump until it rests on the shim and cover.
7. Assemble the gun (2b) and hose (2a), and connect the hose to the pump fluid outlet.
8. Connect the nipple (2d) to the pump air inlet or air regulator (9b) inlet, whichever is applicable. Connect the quick-disconnect coupler (2c) to the air supply hose.

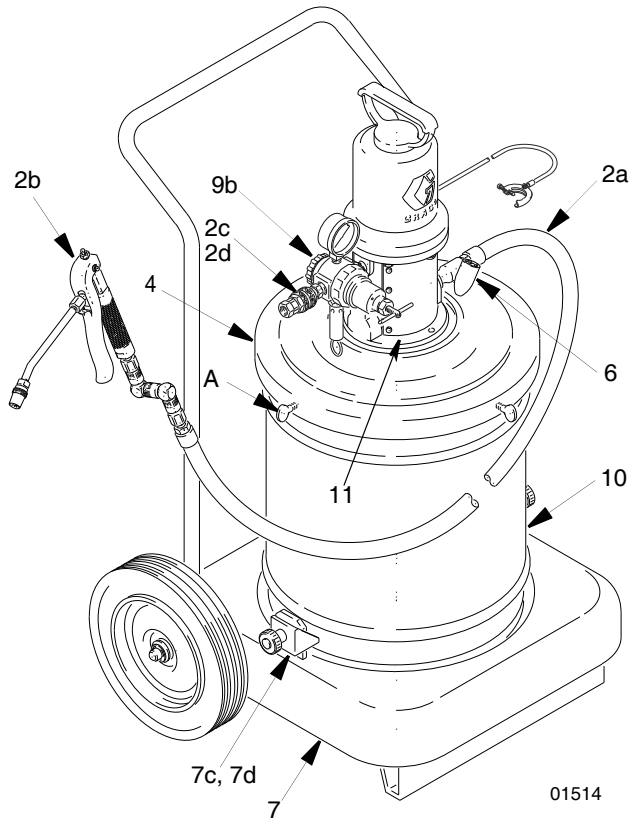

Model 253386 shown

**FIG. 3**



**Models 246914, 246917, 253387 and 253390**  
(FIG. 5 and FIG. 4)

1. Remove the cover from the pail, and scoop the lubricant from the center to the sides of the pail to make its surface concave.
2. Center the follow plate (5) in the pail opening. Press the follow plate firmly downward and rotate it over the lubricant surface to eliminate air pockets and prevent channeling.
3. Place the cover (4) on the pail and tighten the thumbscrews (A).
4. Install shim (11) on top of cover. Insert the pump riser tube through the top of the shim (11) and cover (4). Lower the pump until it rests on the shim and cover.
5. Connect the swivel adapter to the pump fluid outlet. Connect fluid hose (3c) to the swivel adapter. Connect a suitable dispense valve.
6. Connect the swivel adapter to the pump air inlet or air regulator (9b), whichever is applicable. Connect the air hose (3a) to the swivel. Connect the air hose to the air accessories.

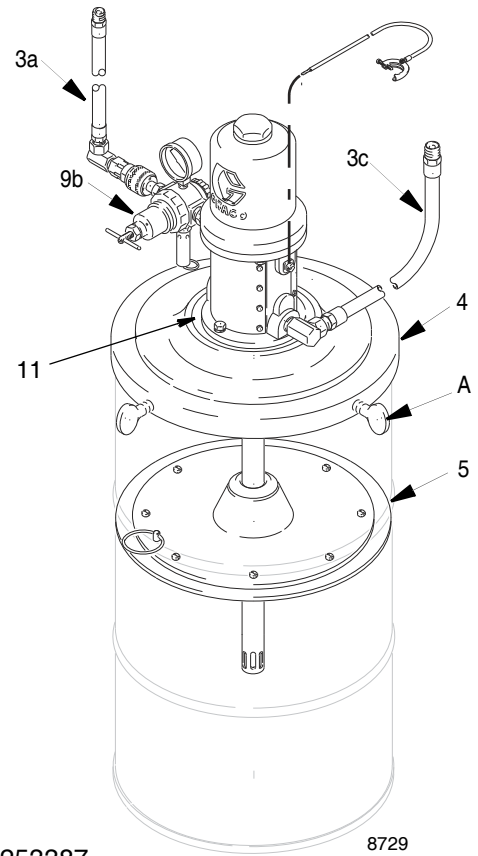

Model 253387

8729

**FIG. 5**

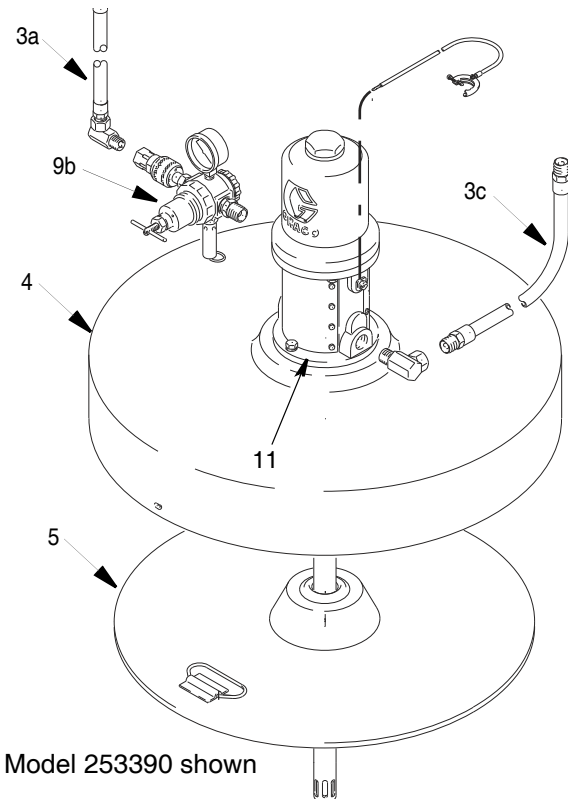

Model 253390 shown

**FIG. 4**

**Models 246915, 246916, 253388 and 253389**

(FIG. 6)

1. For Models 246915 and 253388: Assemble the portable base (8) as shown in the parts drawing on page 15

For Models 246916 and 253389: Assemble the truck (7) as shown in the parts drawing on page 15.

2. Remove the fluid outlet adapter included with the pump, and screw the holster (6) into the pump outlet, using thread sealant.
3. Place an open 120-lb drum of grease on the mounting base or truck, and secure it with hold-down clamps (7d or 8d).

For Models 246915 and 253388: Use pointed end of clamps (8d) for steel drums only. Position the clamp above the drum bead. Tighten bolts (8b). Reverse clamps (8d) to use the flat end for fiber drums.

For Models 246916 and 253389: Use pointed end of clamps (7d) for steel drums only. Position the clamp above the drum bead. Tighten the thumbnuts (7c).

4. Press the follow plate (5) down firmly onto the grease, and rotate it to eliminate air pockets and reduce channeling. Insert the pump through the cover (4). Slide the cover up far enough to let the pump pass easily through the follow plate grommet.
5. Secure the cover on the drum with the thumbscrews (A).
6. Place shim (11) on top of cover. Install pump. Insert the pump riser tube through the top of the shim (11) and cover (4). Lower the pump until it rests on the shim and cover.
7. Assemble the gun (2b) and hose (2a), and connect the hose to the pump fluid outlet.
8. Connect the nipple (2d) to the pump air inlet or air regulator (9b) inlet, whichever is applicable. Connect the quick-disconnect coupler (2c) to the air supply hose.

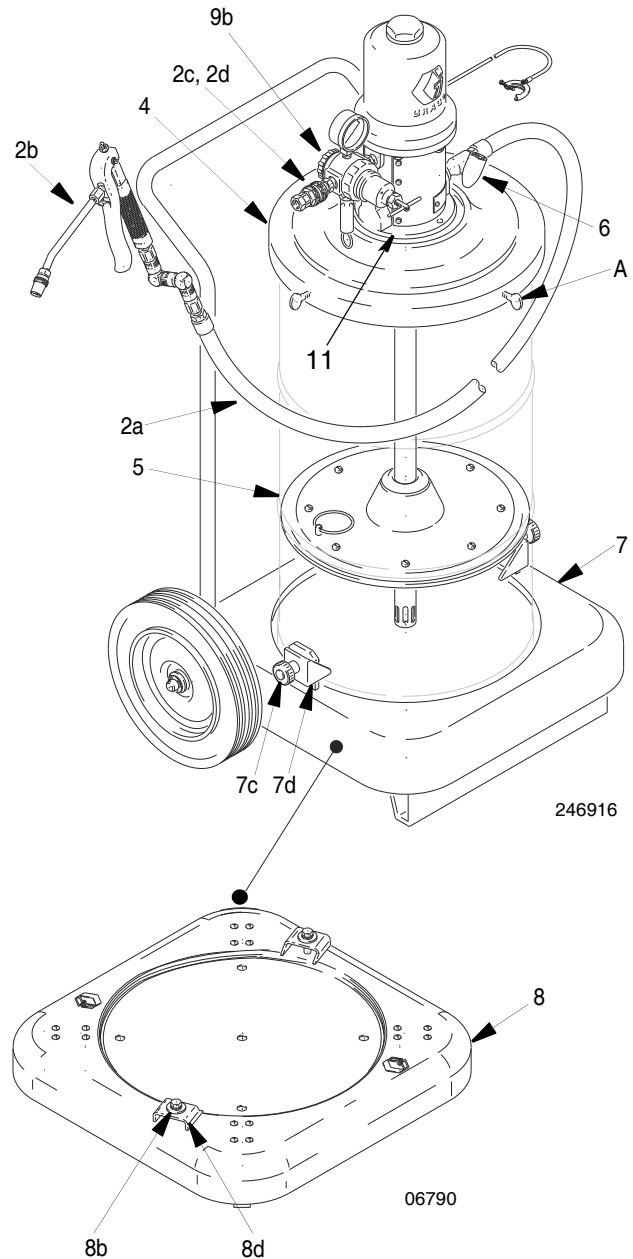

Model 253389 shown

**FIG. 6**

# Operation

## Pressure Relief Procedure



1. Shut off the air to the pump.
2. Bleed off the air pressure by closing the air regulator (self-relieving type), or closing the bleed-type master air valve installed upstream of the air regulator, or disconnecting the air supply hose at the quick-disconnect.
3. Hold a metal part of the gun or valve firmly to the side of a grounded metal waste container and trigger to relieve fluid pressure.

### Start-up: Single or Multiple Pump Systems

1. Close the air regulators and bleed-type master air valves to all but one pump.
2. Open the master air valve from the compressor.
3. For the pump which is connected, trigger the dispensing valve into a grounded metal waste container, making firm metal-to-metal contact between the container and valve. Open the bleed-type master air valve, and open the pump air regulator slowly until the pump is running. When the pump is primed and all air has been pushed out of the lines, release the trigger.
4. If you have more than one pump, repeat this procedure for each pump.

 **NOTE:** When the pump is primed, and with sufficient air supplied, the pump starts when the dispensing valve is opened and shuts off when it is closed.

5. Set the air pressure to each pump at the lowest pressure needed to get the desired results.



**NOTE:** A pump runaway valve can be installed on the air line to automatically shut off the pump if it starts to run too fast.

**NOTE:** Never allow the pump to run dry of the fluid being pumped. A dry pump will quickly accelerate to a high speed, possibly damaging itself. If the pump accelerates quickly or is running too fast, stop it immediately and check the fluid supply. If the supply container is empty and air has been pumped into the lines, prime the pump and lines with fluid, or flush it and leave it filled with a compatible solvent. Be sure to eliminate all air from the fluid system

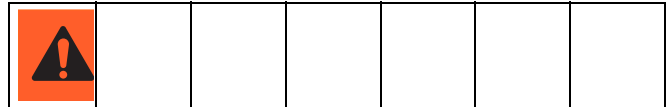

The maximum working pressure of each pump in your system may not be the same. To reduce the risk of over-pressurizing any part of your system, be sure you know the maximum working pressure rating of each pump and its connected components. Never exceed the maximum working pressure of the lowest rated component connected to a particular pump.

To determine the fluid output pressure using the air regulator reading, multiply the ratio of the pump by the air pressure shown on the regulator gauge. For example:

$$50:(1) \text{ ratio} \times 100 \text{ psi air} = 5000 \text{ psi fluid output}$$

$$50:(1) \text{ ratio} \times 0.7 \text{ MPa air} = 35 \text{ MPa fluid output}$$

$$50:(1) \text{ ratio} \times 7 \text{ bar air} = 350 \text{ bar fluid output}$$

Limit the air to the pump so that no air line or fluid line component or accessory is overpressurized.

6. Read and follow the instructions supplied with each component in the system.
7. When shutting off the system, always follow the **Pressure Relief Procedure**.

# Parts

**Models: 246910, 253362, 253384**  
**35-50 lb (16-23 kg) pail size**

Ref.	Part	Description	Qty
1	246909	PUMP, Mini Fire-Ball 225 50:1 (with handle) See manual 309966 for parts.	1
	253361	PUMP, Mini Fire-Ball 225 50:1 (without handle) Model 253362 See manual 309966 for parts.	1
2	236058	DISPENSE KIT; 12 ft (3.7 m) hose; See parts list on page 17.	1
4	222059	COVER; includes items 4a-4h	1
4a	207617	• COVER, pail	1
4b	168102	• PLATE, stop, pump	
4c	158048	• BUMPER, button, rubber	1
4d	159608	• RIVET	1
4e	150868	• HOLDER, gun	1
4f	100220	• SCREW, thumb	3
4g	100025	• NUT, 1/4 npsm thd	1
4h	100579	• PIN, cotter; 1/8" x 1"	1
5	220653	FOLLOW PLATE, model 253384. See manual 306345 for parts.	1
	24F901	FOLLOW PLATE, models 246910, 253362 See manual 306345 for parts.	1
9	240979	CE Kit for 253384 See parts on page 19.	1

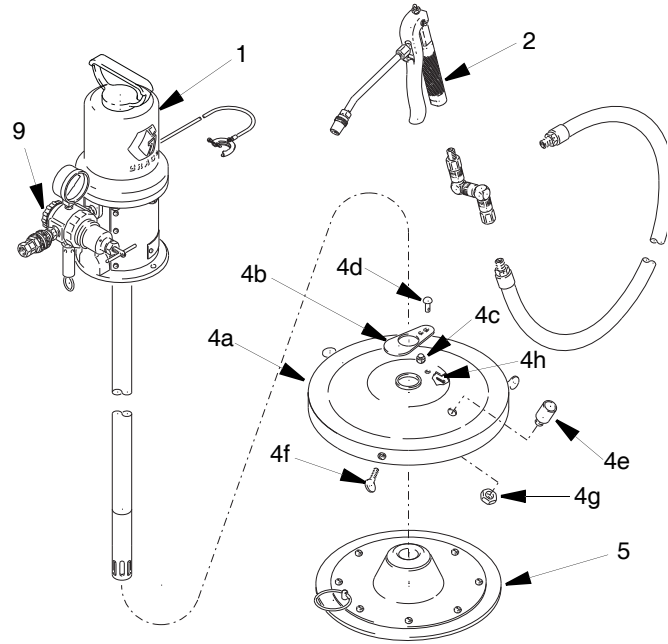

**FIG. 7: Model 253384 shown**

**Models: 246911, 253385**  
**35-50 lb (16-23 kg) pail size**

Ref	Part	Description	Qty
1	246909	PUMP, Mini Fire-Ball 225 50:1 See manual 309966 for parts.	1
2	236058	DISPENSE KIT; 12 ft (3.7 m) hose; See parts list on page 17.	1
4	204574	COVER, model 253385. See manual 306345 for parts.	1
	24R350	COVER, model 245911. See manual 306345 for parts.	1
6	203976	HOLSTER	1
9	240979	CE Kit for 253385 See parts on page 19.	1
10	204134	PAIL	1
11	176270	SHIM	1

**Models: 246913, 253386**  
**35-50 lb (16-23 kg) pail size**

Ref	Part	Description	Qty
1	246909	PUMP, Mini Fire-Ball 225 50:1 See manual 309966 for parts.	1
2	236058	DISPENSE KIT; 12 ft (3.7 m) hose; See parts list on page 17.	1
4	204574	COVER, model 253386. See manual 306345 for parts.	1
	24R350	COVER, model 246913. See manual 306345 for parts.	1
6	203976	HOLSTER	1
7	203650	TRUCK, 2-wheel; See parts list on page 18.	1
9	240979	CE Kit for 253386 See parts on page 19.	1
10	204134	PAIL	1
11	176270	SHIM	1

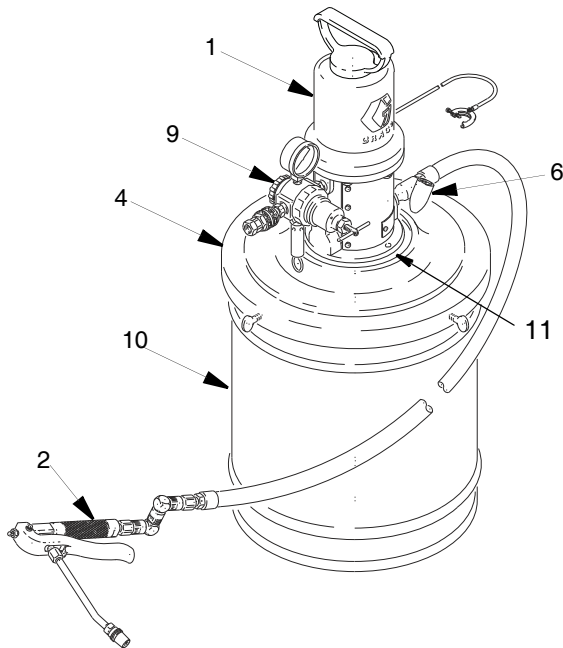

**FIG. 8: Model 253385 shown**

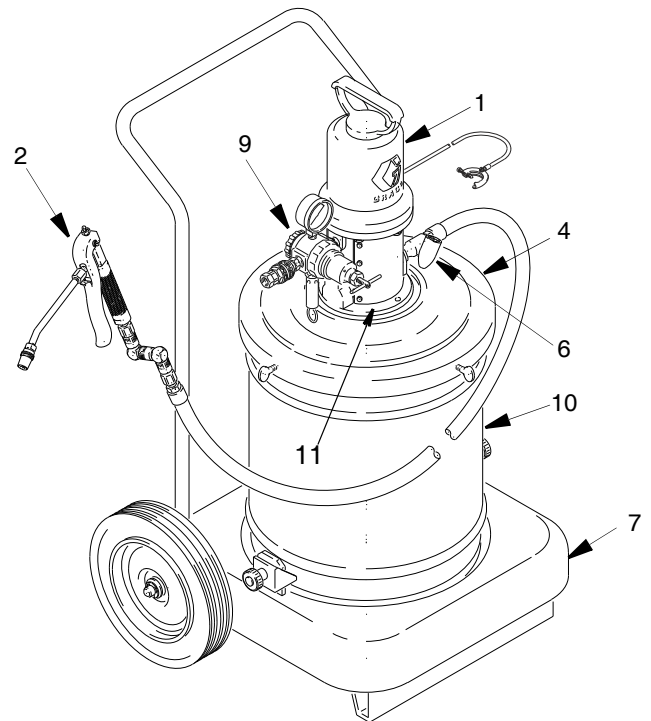

**FIG. 9: Model 253386 shown**

**Models: 246914, 253387**  
**120 lb (55 kg) drum size**

Ref	Part	Description	Qty
1	246780	PUMP, Mini Fire-Ball 225 50:1 See manual 309966 for parts.	1
3	222072	Hose and Fitting Kit; 6 ft (1.8 m) hose; See parts list on page 17.	1
4	204574	COVER, model 253387. See manual 306345 for parts.	1
	24R350	COVER, model 246914. See manual 306345 for parts.	1
5	220654	FOLLOW PLATE, model 253387. See manual 306345 for parts.	1
	24F902	FOLLOW PLATE, model 246914. See manual 306345 for parts.	1
9	240979	CE Kit for 253387 See parts on page 19.	1
11	176270	SHIM	1

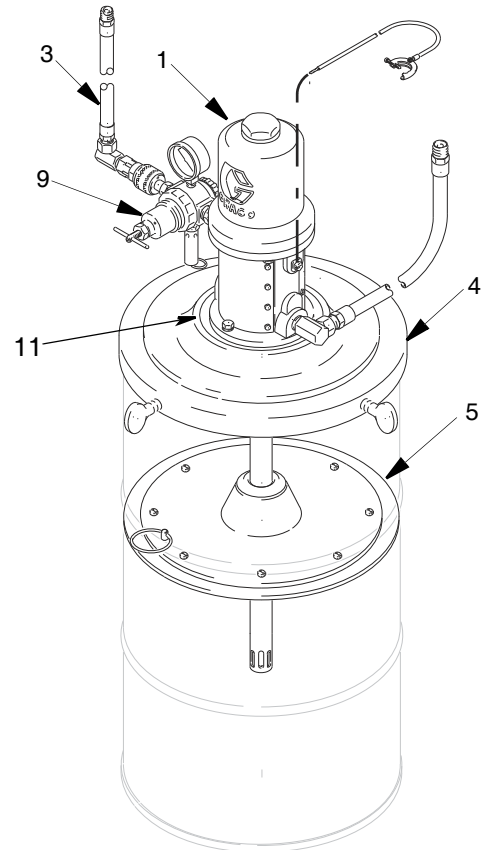

**FIG. 10: Model 253387 shown**

**Models: 246915, 253388**  
**120 lb (55 kg) drum size**

Ref	Part	Description	Qty
1	246780	PUMP, Mini Fire-Ball 225 50:1 See manual 309966 for parts.	1
2	236058	DISPENSE KIT; 12 ft (3.7 m) hose; See parts list on page 17.	1
4	204574	COVER, model 253388. See manual 306345 for parts.	1
	24R350	COVER, model 246915. See manual 306345 for parts.	1
5	220654	FOLLOW PLATE, model 253388. See manual 306345 for parts.	1
	24F902	FOLLOW PLATE, model 246915. See manual 306345 for parts.	1
6	203976	HOLSTER	1
8	203622	PORTABLE BASE; See parts list on page 18.	1
9	240979	CE Kit for 235388 See parts on page 19.	1
11	176270	SHIM	1

**Models: 246916, 253389**  
**120 lb (55 kg) drum size**

Ref	Part	Description	Qty
1	246780	PUMP, Mini Fire-Ball 225 50:1 See manual 309966 for parts.	1
2	236058	DISPENSE KIT; 12 ft (3.7 m) hose; See parts list on page 17.	1
4	204574	COVER, model 253389. See manual 306345 for parts.	1
	24R350	COVER, model 246916. See manual 306345 for parts.	1
5	220654	FOLLOW PLATE, model 253389. See manual 306345 for parts.	1
	24F902	FOLLOW PLATE, model 246916. See manual 306345 for parts.	1
6	203976	HOLSTER	1
7	203650	TRUCK, 2-wheel; See parts list on page 18.	1
9	240979	CE Kit for 235389 See parts on page 19.	1
11	176270	SHIM	1

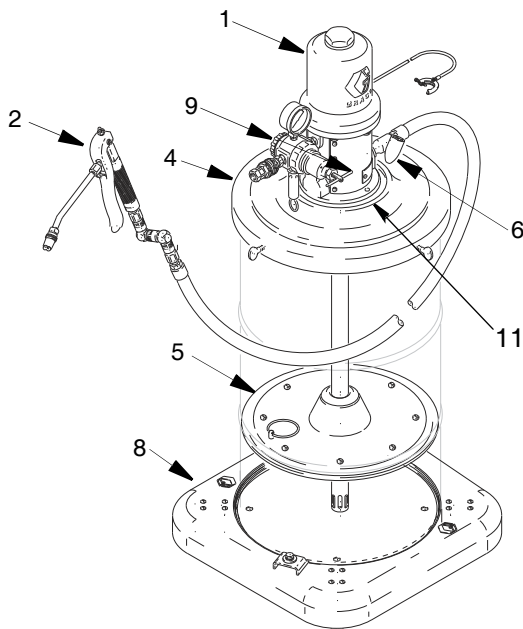

**FIG. 11: Model 253388 shown**

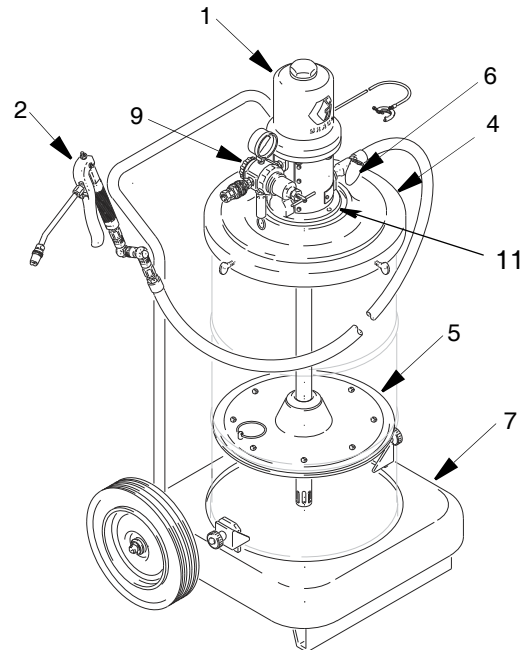

**FIG. 12: Model 253389 shown**

**Models: 246917, 253390**  
**400 lb (180 kg) drum size**

Ref	Part	Description	Qty
1	246781	PUMP, Mini Fire-Ball 225 50:1 See manual 309966 for parts.	1
3	222072	Hose and Fitting Kit; 6 ft (1.8 m) hose; See parts list on page 17.	1
4	200326	COVER See manual 306345 for parts.	1
5	223845	FOLLOW PLATE, model 253390. See manual 306345 for parts.	1
	24F903	FOLLOW PLATE, model 246917. See manual 306345 for parts.	1
9	240979	CE Kit for 253389 See parts on page 19.	1
11	176270	SHIM	1

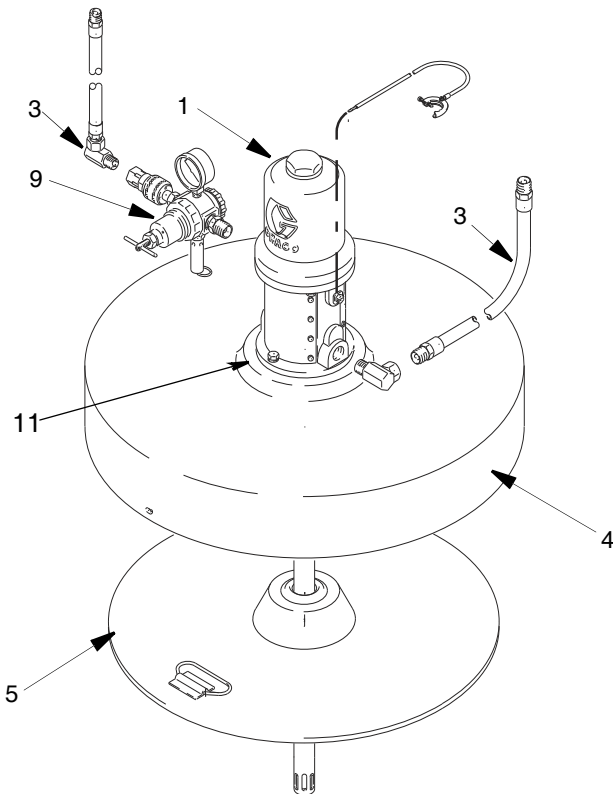

**FIG. 13: Model 253390 shown**



# Components and Kits

## Ref No. 2: Dispense Kit 236058

Ref	Part	Description	Qty
2a	109151	HOSE; 1/4 npt(mbe) x 12 ft (3.7 m)	1
2b	242056	VALVE, grease dispense See manual 309032	1
2c	114558	COUPLER, quick-disconnect	1
2d	169971	NIPPLE, quick-disconnect	1
2e	202577	Z-SWIVEL	1

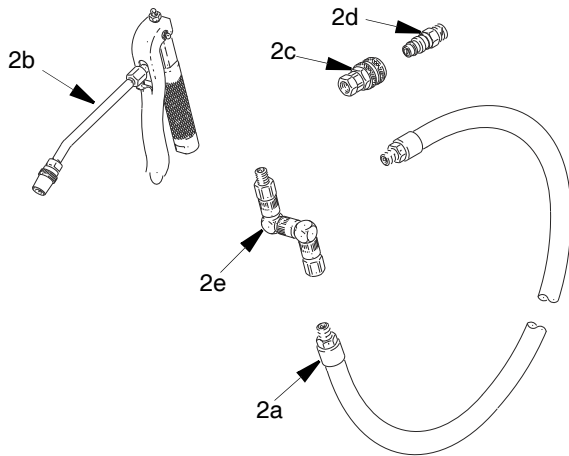

FIG. 14

## Ref No. 3: Hose and Fitting Kit 222072

Ref	Part	Description	Qty
3a	203320	HOSE; air, buna-N; 3/8 npt(mbe) x 6 ft (1.8 m)	1
3b	155494	UNION, 90°; 3/8 npt(m) x 3/8 npsm(f) swivel	1
3c	109150	HOSE; fluid, buna-N; 1/4 npt(mbe) x 6 ft (1.8 m)	1
3d	155541	UNION, 90°; 1/4 npt(m) x 1/4 npsm(f) swivel	1

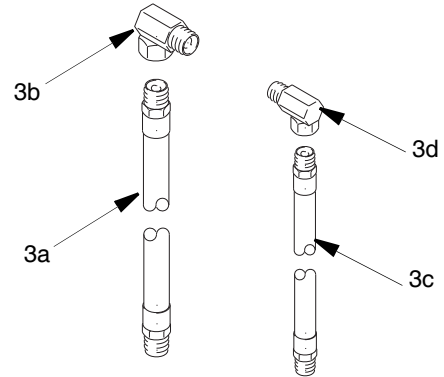
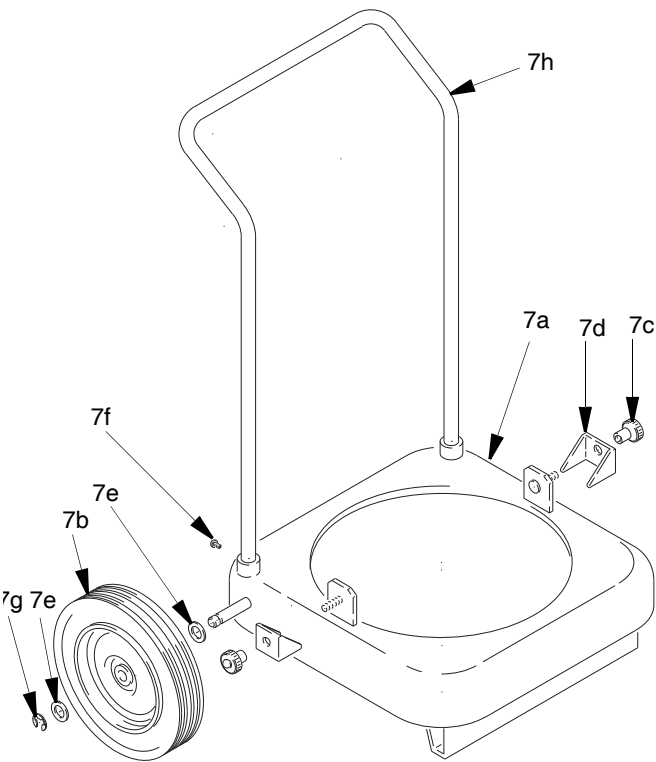

FIG. 15

**Ref No. 7: Truck 203650**

Ref	Part	Description	Qty
7a	203651	BASE, truck; bare	1
7b	101251	WHEEL	2
7c	159912	NUT, thumb, 5/16-18	2
7d	159913	CLAMP, hold down; <i>(for steel drums only)</i>	2
7e	154636	WASHER, 5/8", 16 GA	4
7f	100609	SCREW, machine, panhead; 1/4-20 x 0.375"	2
7g	101242	RING, retaining	2
7h	159924	HANDLE, truck	1



**FIG. 16**

**Ref No. 8: Portable Base 203622**

Ref	Part	Description	Qty
8a	191750	BASE, drum	1
8b	102547	BOLT, hex head; 5/16"-18 x 1.5"	2
8c	100214	WASHER, lock	2
8d	191747	BRACKET	2
8e	100132	WASHER, flat	2
8f	113660	RIVET	16
8g	113646	CASTER; polyurethane	4

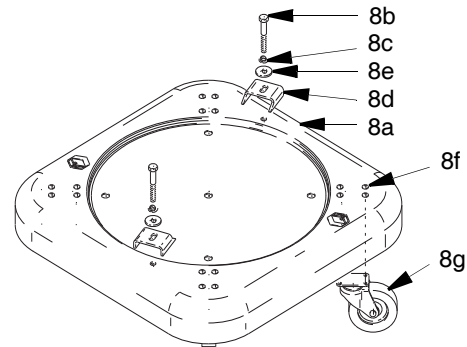

**FIG. 17**

## Ref No.9: CE Kit 240979

Ref	Part	Description	Qty
9a	156849	NIPPLE	1
9b	109075	REGULATOR, air, with gauge	1
9c	103347	VALVE, safety	1
9d	222011	CLAMP, grounding	1
9e	†	CE Label (not shown)	1

† **Attention:** To comply with CE directives, the CE identification label must be affixed to the back of the cart or to the top of the drum cover. Permanently mark the date of assembly on the label.

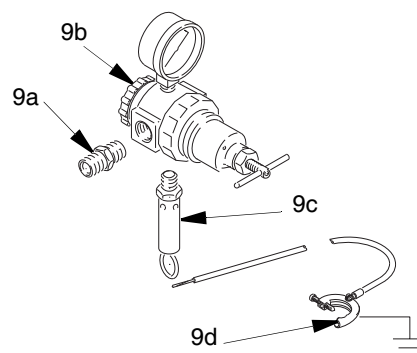

FIG. 18

## Sound Data

See the pump instruction manual for technical data including wetted parts, port sizes, maximum air consumption, maximum delivery, and so on. Sound data for the air motors of the pumps on these portable units is as follows:

Tested at 140 psi (1.0 MPa, 10 bar) at 100 cycles per minute	
Sound Pressure Level, measured at 1 meter from unit	77.8 dB(A)
Sound Power Level, tested in accordance with ISO 9614-2	85.6 dB(A)

# Graco Information

For the latest information about Graco products, visit [www.graco.com](http://www.graco.com).

For patent information, see [www.graco.com/patents](http://www.graco.com/patents).

**TO PLACE AN ORDER**, contact your Graco distributor or call to identify the nearest distributor.

**Phone:** 612-623-6928 **or Toll Free:** 1-800-533-9655, **Fax:** 612-378-3590

*All written and visual data contained in this document reflects the latest product information available at the time of publication.  
Graco reserves the right to make changes at any time without notice.*

Original instructions. This manual contains English. MM 309678

**Graco Headquarters:** Minneapolis

**International Offices:** Belgium, China, Japan, Korea

**GRACO INC. AND SUBSIDIARIES • P.O. BOX 1441 • MINNEAPOLIS MN 55440-1441 • USA**

**Copyright 2007, Graco Inc. All Graco manufacturing locations are registered to ISO 9001.**

[www.graco.com](http://www.graco.com)

revised January 2015

## Free Manuals Download Website

<http://myh66.com>

<http://usermanuals.us>

<http://www.somanuals.com>

<http://www.4manuals.cc>

<http://www.manual-lib.com>

<http://www.404manual.com>

<http://www.luxmanual.com>

<http://aubethermostatmanual.com>

Golf course search by state

<http://golfingnear.com>

Email search by domain

<http://emailbydomain.com>

Auto manuals search

<http://auto.somanuals.com>

TV manuals search

<http://tv.somanuals.com>