

NOTE:
Please read all instructions
carefully before using this
product

Table of Contents

Safety Notice

Hardware Identifier

Assembly Instruction

Parts List

Warranty

Ordering Parts

Model
WMGG-368

Retain This
Manual for
Reference

08-04-08

OWNER'S
MANUAL



GOLD'S GYM WEIGHT BENCH WMGG-368

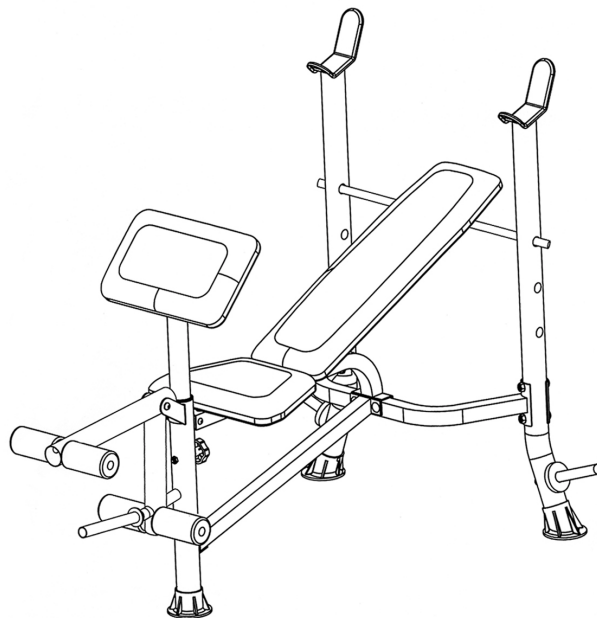

IMPEX[®] INC.

14777 DON JULIAN RD., CITY OF INDUSTRY, CA 91746

Tel: (800) 999-8899 Fax: (626) 961-9966

www.impex-fitness.com

info@impex-fitness.com

TABLE OF CONTENTS

BEFORE YOU BEGIN.....	1
IMPORTANT SAFETY NOTICES.....	2
HARDWARE IDENTIFIER.....	4
ASSEMBLY INSTRUCTIONS.....	5
EXPLODED DIAGRAM.....	10
PARTS LIST.....	11
WARRANTY.....	12
ORDERING PARTS.....	12

BEFORE YOU BEGIN

Thank you for selecting the GOLD'S GYM WMGG-368 Weight Bench by IMPEX[®] INC. For your safety and benefit, read this manual carefully before using the machine. As a manufacturer, we are committed to provide you complete customer satisfaction. If you have any questions, or find there are missing or damaged parts, we guarantee you complete satisfaction through direct assistance from our factory. To avoid unnecessary delays, *please call our TOLL-FREE customer service number*. Our Customer Service Agents will provide immediate assistance to you.

Toll-Free Customer Service Number

1-800-999-8899

Mon. - Fri. 9 a.m. - 5 p.m. PST

www.impex-fitness.com

info@impex-fitness.com

IMPORTANT SAFETY NOTICE

PRECAUTIONS

This exercise machine is built for optimum safety. However, certain precautions apply whenever you operate a piece of exercise equipment. Be sure to read the entire manual before you assemble or operate your machine. In particular, note the following safety precautions:

1. **Keep children and pets away from the machine at all times. DO NOT leave children unattended in the same room with the machine.**
2. Only one person at a time should use the machine.
3. If the user experiences dizziness, nausea, chest pain, or any other abnormal symptoms, STOP the workout at once. CONSULT A PHYSICIAN IMMEDIATELY.
4. Position the machine on a clear, leveled surface. DO NOT use the machine near water or outdoors.
5. Keep hands and feet away from all moving parts.
6. Always wear appropriate workout clothing when exercising. DO NOT wear robes or other clothing that could become caught in the machine. Running or aerobic shoes are also required when using the machine.
7. Use the machine only for its intended use as described in this manual. DO NOT use attachments not recommended by the manufacturer.
8. Do not place any sharp object around the machine.
9. Disabled person should not use the machine without a qualified person or physician in attendance.
10. Before using the machine to exercise, always do stretching exercises to properly warm up.
11. Never operate the machine if the machine is not functioning properly.
12. A spotter is recommended during exercise.

CARE AND MAINTENANCE

1. Lubricate moving parts with WD-40 or light oil periodically.
2. Inspect and tighten all parts before using the machine.
3. The machine can be cleaned using a damp cloth and mild non-abrasive detergent. DO NOT use solvents.
4. Maximum weight capacity on the uprights: 200 lbs.
5. Maximum user's weight: 250 lbs.
6. Maximum weight capacity on the leg developer: 100 lbs.

WARNING: BEFORE BEGINNING ANY EXERCISE PROGRAM, CONSULT YOUR PHYSICIAN. THIS IS ESPECIALLY IMPORTANT FOR INDIVIDUALS OVER THE AGE OF 35 OR PERSONS WITH PRE-EXISTING HEALTH PROBLEMS. READ ALL INSTRUCTIONS BEFORE USING ANY FITNESS EQUIPMENT. IMPEX INC. ASSUMES NO RESPONSIBILITY FOR PERSONAL INJURY OR PROPERTY DAMAGE SUSTAINED BY OR THROUGH THE USE OF THIS PRODUCT. SAVE THESE INSTRUCTIONS.

WARNING LABEL REPLACEMENT

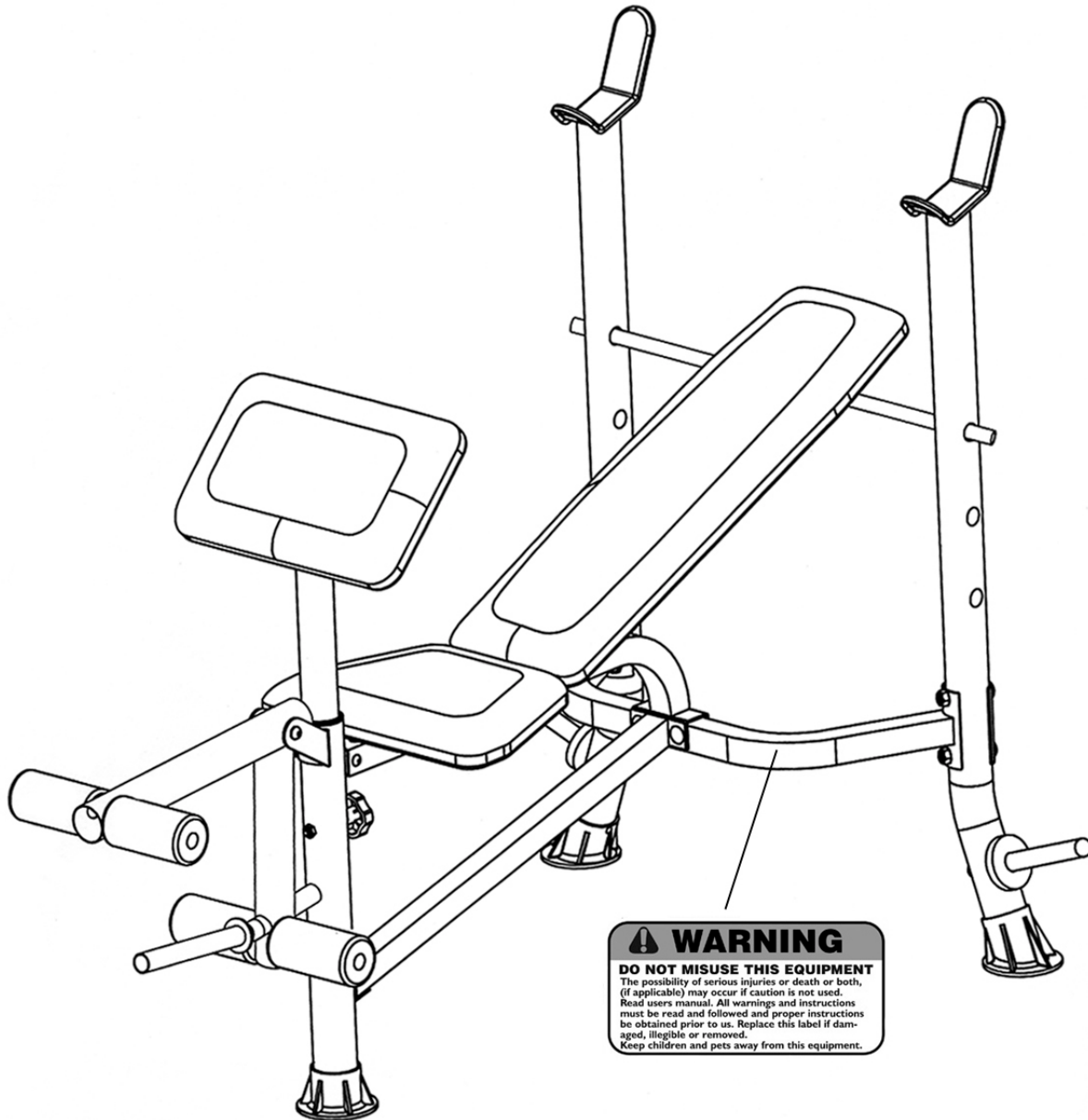

The Warning Label shown here has been placed on the Cross Brace. If the label is missing or illegible, please call customer service at 1-800-999-8899 for replacement. Apply the label in location shown.

HARDWARE IDENTIFIER

NOTE: The following parts are not drawn to scale. Please use your own ruler to measure the size.

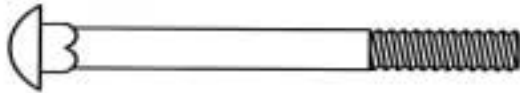

#29 M10 x 3 1/2" Carriage Bolt (Qty 4)

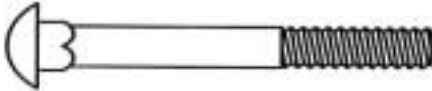

#30 M10 x 2 1/2" Carriage Bolt (Qty 2)



#32 M8 x 3 1/2" Allen Bolt (Qty 1)



#34 M6 x 1 1/2" Hex Bolt (Qty 4)



#41 M6 x 1 1/2" Hex Bolt (Qty 4)

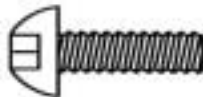

#33 M10 x 1" Allen Bolt (Qty 2)



#31 M8 x 3/4" Allen Bolt (Qty 6)



#39 ST5 Screw (Qty 2)



#38 Curved Washer (Qty 2)



#37 Ø 1/2" Washer (Qty 8)



#36 Ø 3/4" Washer (Qty 8)



#35 Ø 1" Washer (Qty 6)



#40 M10 Aircraft Nut (Qty 6)



#28 M8 Aircraft Nut (Qty 1)



ASSEMBLY INSTRUCTION

Tools Required for Assembling the Machine: Two Adjustable Wrenches and Allen Wrenches

NOTE: It is strongly recommended that two or more people assemble this machine to avoid possible injury.

STEP 1 (See Diagram 1)

- A.) Plug the two Upright End Caps (#17) onto the bottom of the Right & Left Upright Beams (#1 & #2). Secure each Cap with a ST5 Screw (#39).
- B.) Connect the two Upright Beams by a Cross Brace (#4) in the Mid-span. Secure them with two M10 x 3 1/8" Carriage Bolts (#29), one Curved Bracket (#12), two $\text{\O} \frac{3}{4}$ " Washers (#35), and two M10 Aircraft Nuts (#40) on each end of the Cross Brace. **DO NOT tighten the bolts and nuts.**
- C.) Attach a Weight Post (#8) to the Right Upright Beam. Secure it with one M10 x 1" Allen Bolt (#33) and Curved Washer (#38). Slide a 2 3/8" Rubber Bumper (#14) onto the Weight Post.
- D.) Insert the Backrest Adjustment Bar (#19) through the selected holes on the Upright Beams to obtain desired incline of Backrest. **Ensure that the Backrest Adjustment Bar can be easily removed and re-inserted before you tighten the nuts and bolts installed in STEP 1-B to achieve maximum alignment.**

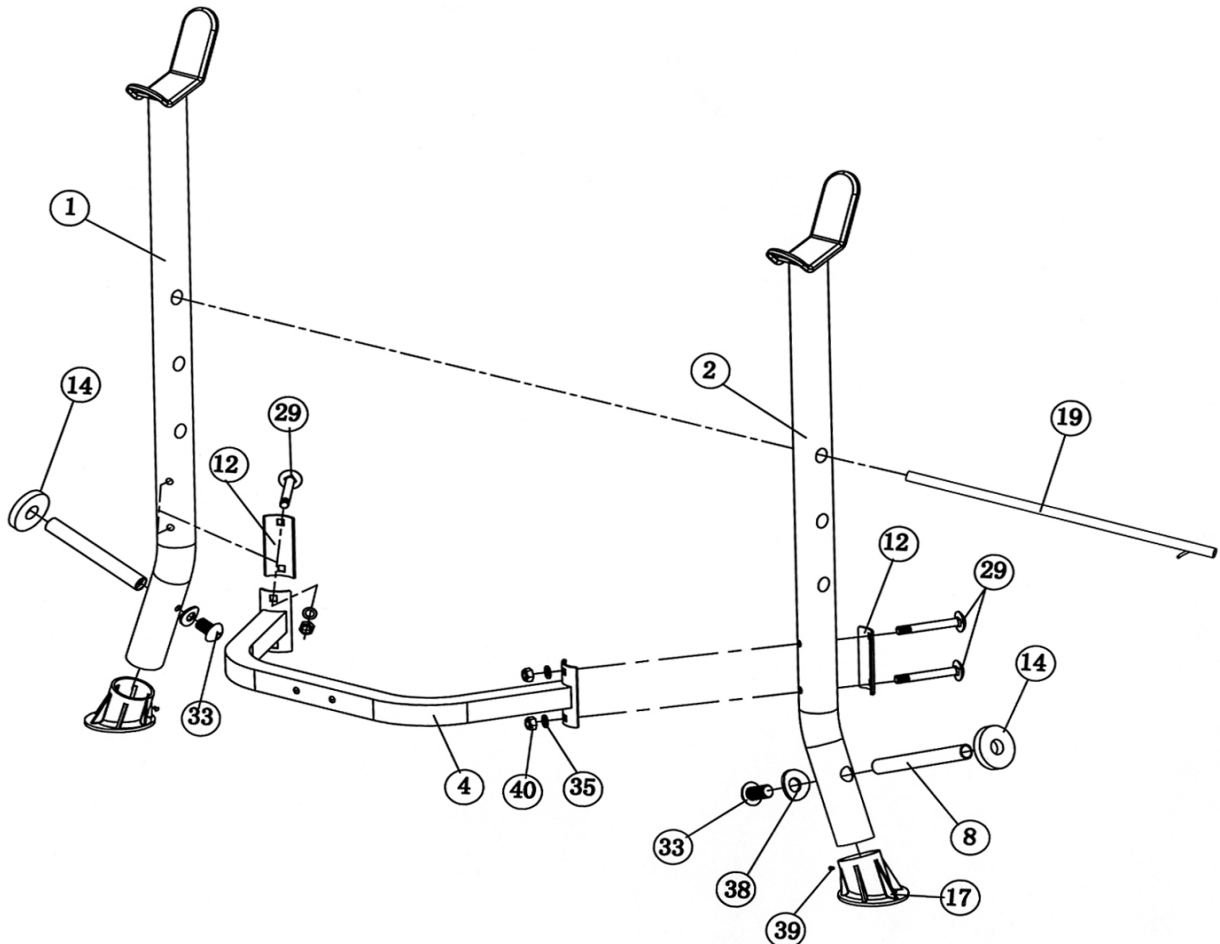

STEP 2 (See Diagram 2)

- A.) Plug a Front Leg End Cap (#20) onto the bottom of Front Leg (#5). Attach the Front Leg to the Main Seat Support (#3). Secure it with three M8 x 5/8" Allen Bolts (#31) and \varnothing 5/8" Washers (#36). **DO NOT tighten the Bolts yet.**
- B.) Attach the Main Seat Support to the Cross Brace (#4). Attach the Main Seat Stabilizer (#9) to the Main Seat Support. Align the holes. Secure the Main Seat Support, Main Stabilizer, and Cross Brace together with two M10 x 2 1/2" Carriage Bolts (#30), \varnothing 3/4" Washers (#35), and M10 Aircraft Nuts (#40). **DO NOT tighten the Bolts yet.**
- C.) Attach the other end of Main Seat Stabilizer (#9) to the Front Leg (#5). Secure it with one M8 x 5/8" Allen Bolt (#31) and \varnothing 5/8" Washer (#36).
- D.) **Securely tighten all Nuts and Bolts previously installed.**

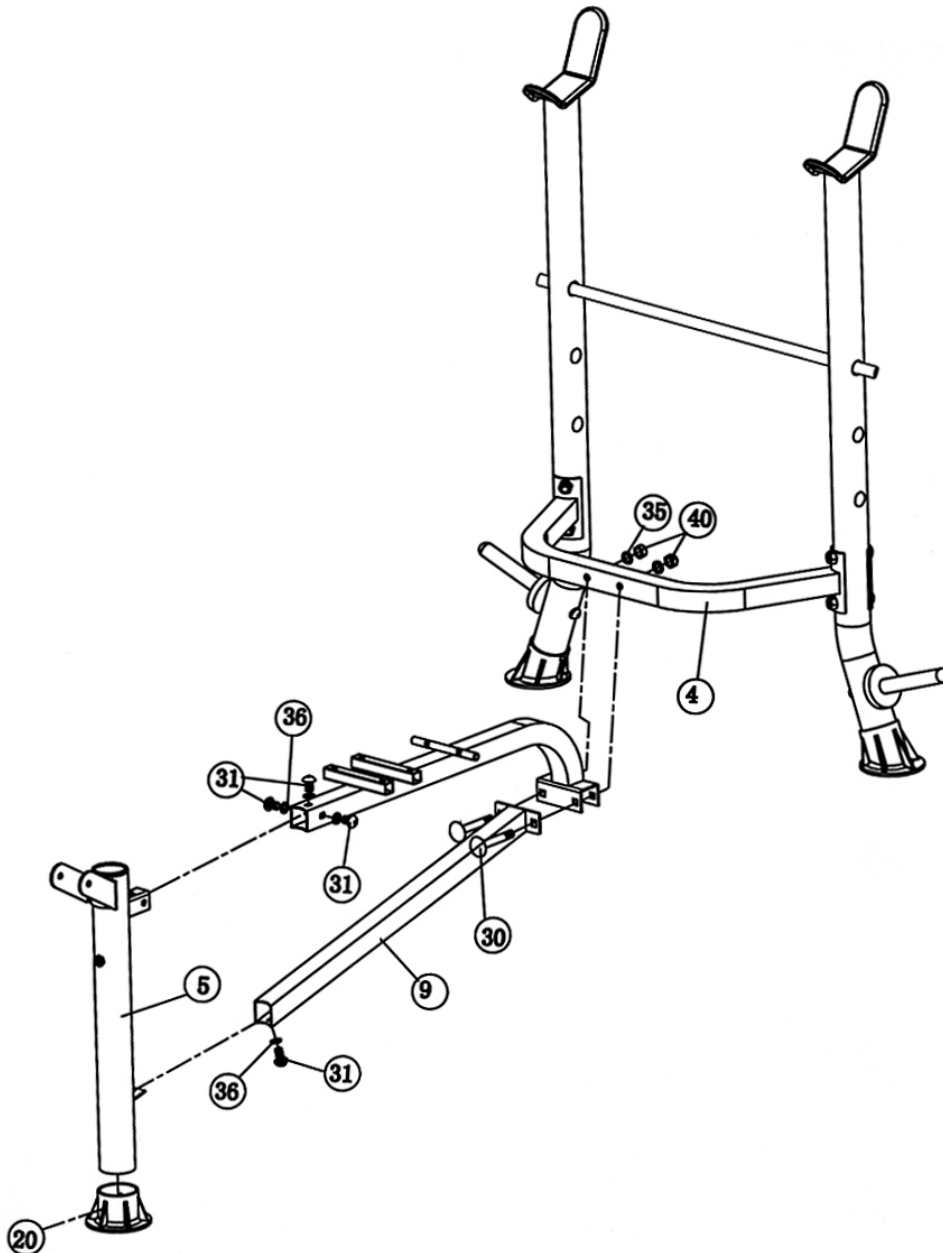

STEP 3 (See Diagram 3)

- A.) Attach the Leg Developer (#7) to the Front Leg (#5). Secure it with one M8 x 3 1/8" Allen Bolt (#32), two Ø 5/8" Washers (#36), and one M8 Aircraft Nut (#28).
- B.) Insert two Foam Tubes (#11) halfway through the holes on the Leg Developer. Push four Foam Rolls (#24) onto the Tubes from both sides.

DIAGRAM 3

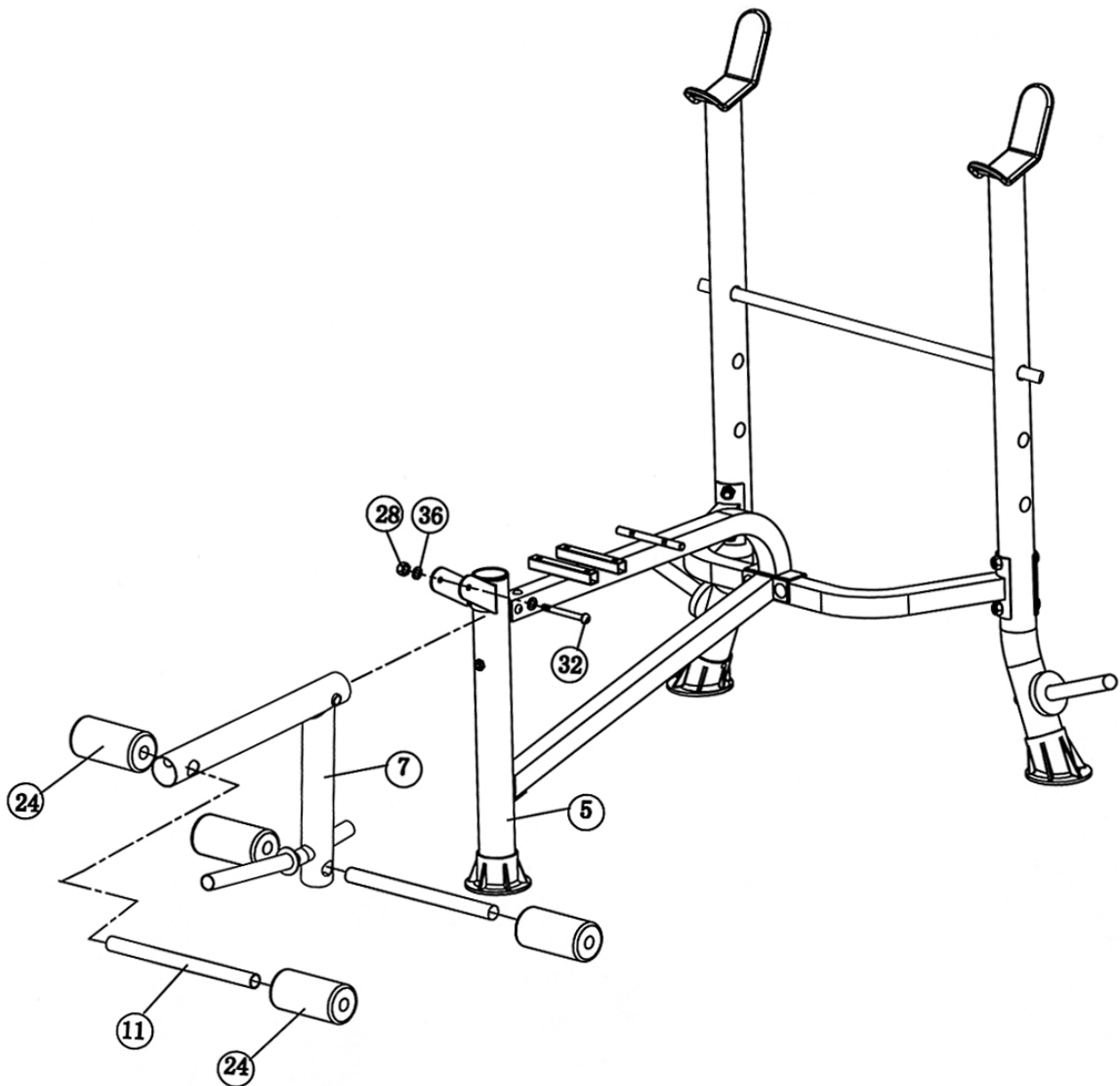

STEP 4 (See Diagram 4)

- A.) Attach the Backrest Supports (#10) onto both ends of the pivot on the Main Seat Support (#3). Place the other end rest against the Backrest Adjustment Bar (#28).
- B.) Place the Backrest Board (#27) onto the Backrest Supports. Secure it with four M6 x 1 1/2" Hex Bolts (#34) and Ø 1/2" Washers (#37).
- C.) Place the Seat Pad (#26) onto the Main Seat Support. Secure it with four M6 x 1 1/2" Hex Bolts (#41) and Ø 1/2" Washers (#37).

DIAGRAM 4

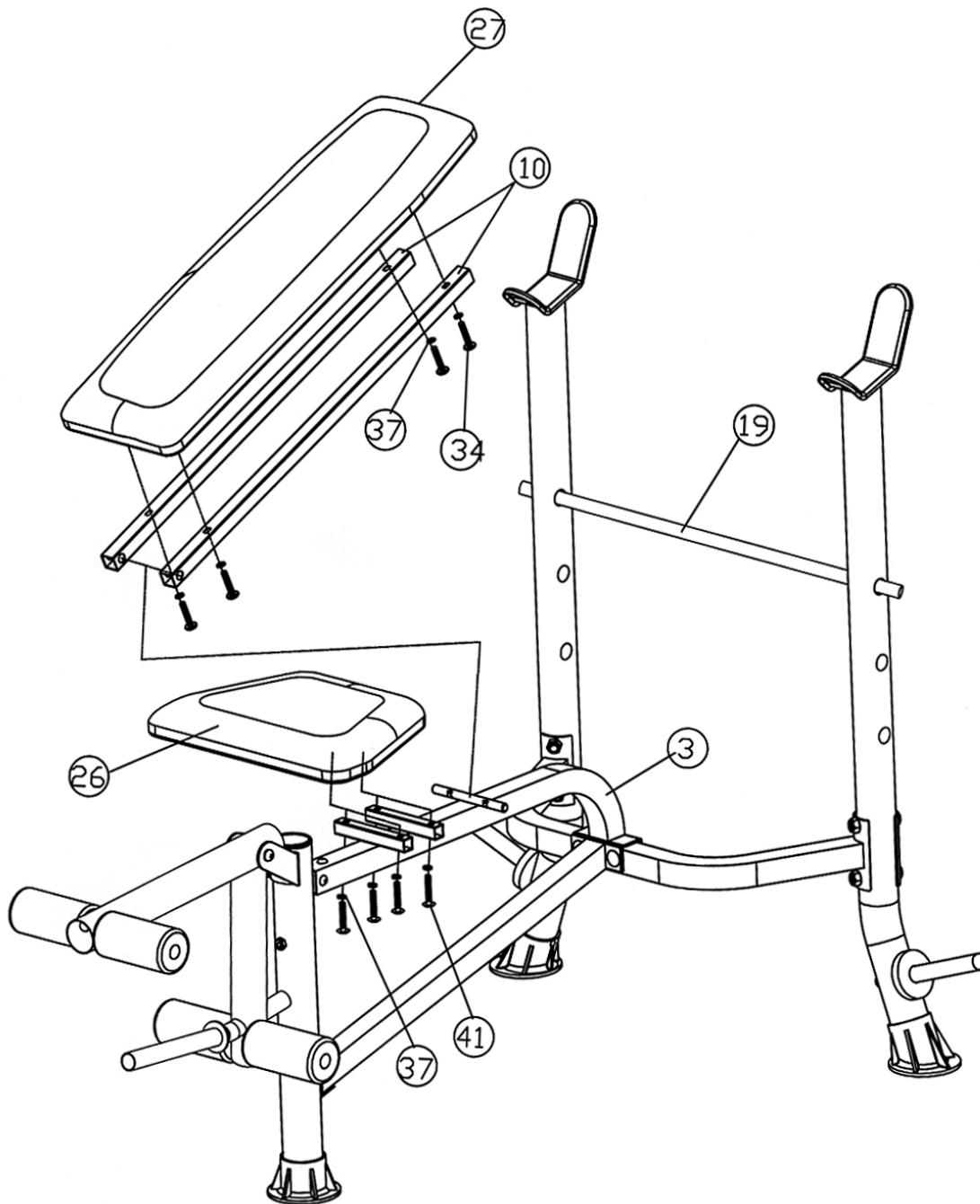

STEP 5 (See Diagram 5)

- A.) Attach the Arm Curl Pad (#25) to the Arm Curl Stand (#6). Secure it with two M8 x 5/8" Allen Bolts (#31) and Ø 5/8" Washers (#36).
- B.) Insert the Arm Curl Stand into the top opening on the Front Leg. Secure it with a Lock Knob (#13).
- C.) When using Leg Developer, remove the Arm Curl Stand from the Front Leg.

DIAGRAM 5

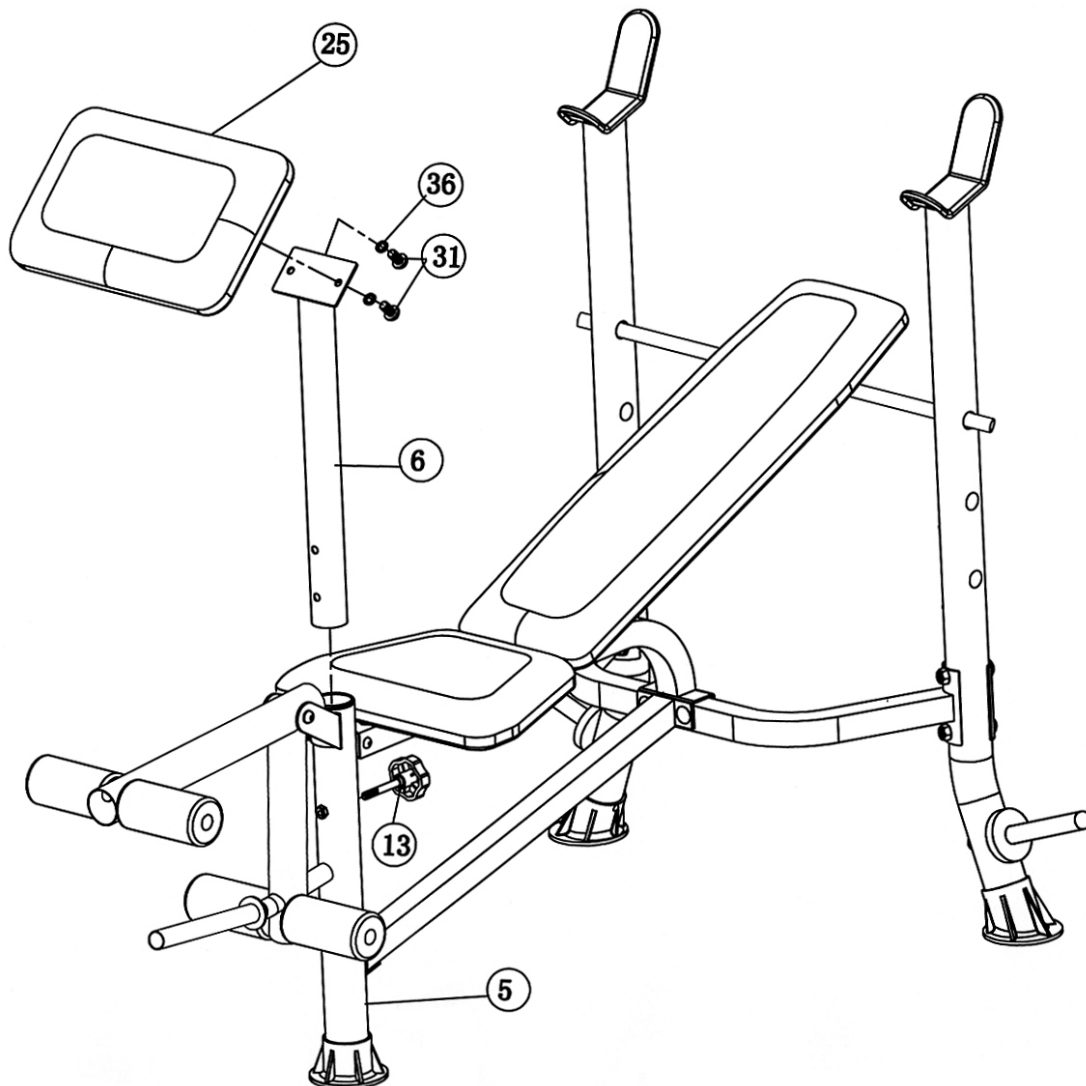

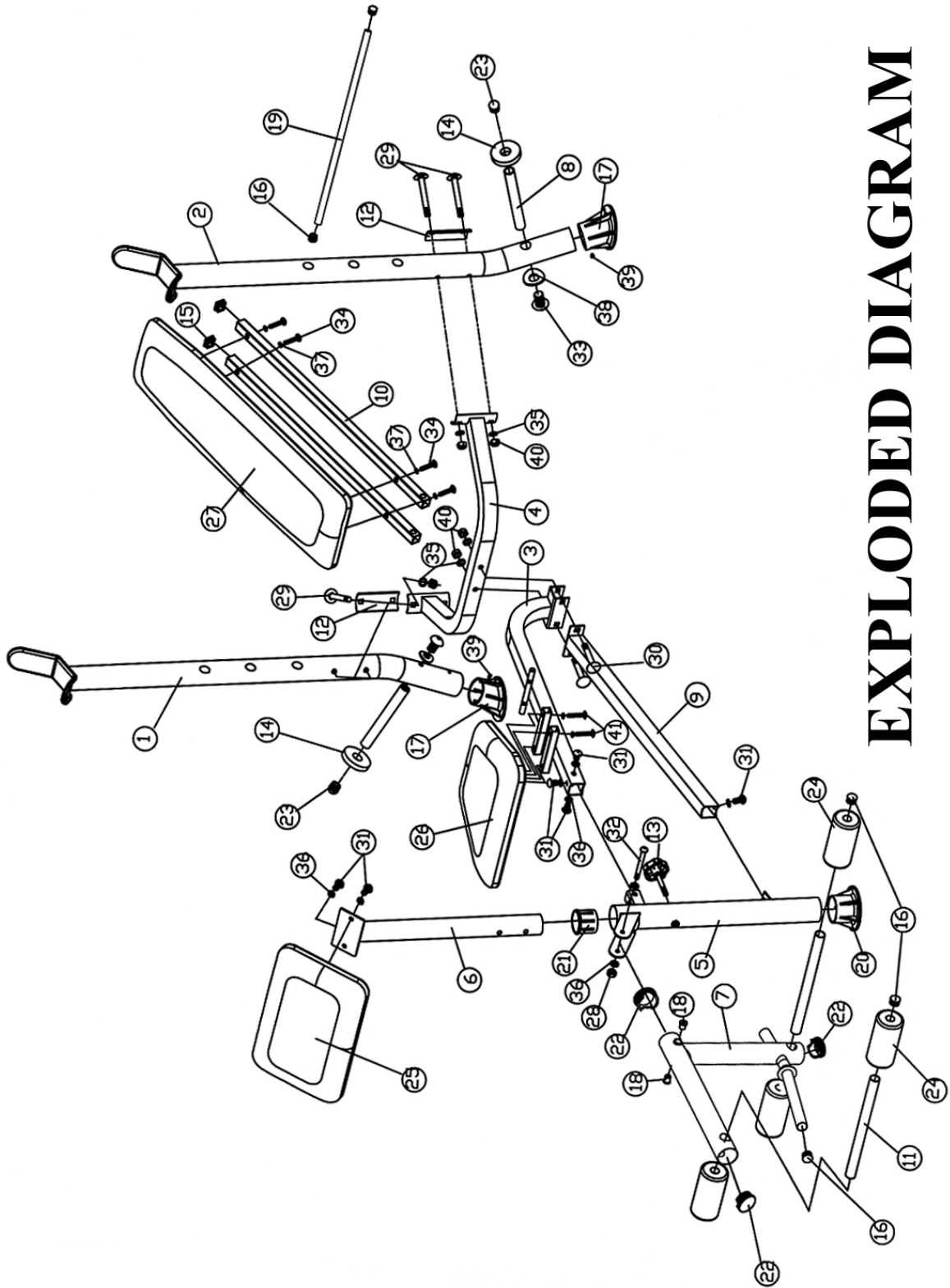

EXPLODED DIAGRAM

PARTS LIST

KEY NO.	DESCRIPTION	QUANTITY
1	Right Upright Beam	1
2	Left Upright Beam	1
3	Main Seat Support	1
4	Cross Brace	1
5	Front Leg	1
6	Arm Curl Stand	1
7	Leg Developer	1
8	Weight Post	2
9	Main Seat Stabilizer	1
10	Backrest Support	2
11	Foam Tube	2
12	Curved Bracket	2
13	Lock Knob	1
14	2 3/8" Rubber Bumper	2
15	1" Square End Cap	2
16	Ø 1" End Cap	8
17	Upright End Cap	2
18	Ø 3/4" Bushing	2
19	Backrest Adjustment Bar	1
20	Front Leg End Cap	1
21	Ø 2 3/8" x Ø 2" Sleeve	1
22	Ø 2" End Cap	3
23	Ø 1" Con-shaped End Cap	2
24	Foam Roll	4
25	Arm Curl Pad	1
26	Seat Pad	1
27	Backrest Board	1
28	M8 Aircraft Nut	1
29	M10 x 3 1/8" Carriage Bolt	4
30	M10 x 2 1/2" Carriage Bolt	2
31	M8 x 5/8" Allen Bolt	6
32	M8 x 3 1/8" Allen Bolt	1
33	M10 x 1" Allen Bolt	2
34	M6 x 1 1/2" Hex Bolt	4
35	Ø 3/4" Washer	6
36	Ø 5/8" Washer	8
37	Ø 1/2" Washer	8
38	Curved Washer	2
39	ST5 Screw	2
40	M10 Aircraft Nut	6
41	M6 x 1 1/4" Hex Bolt	4

IMPEX[®] INC.

LIMITED WARRANTY

IMPEX Inc. ("IMPEX[®]") warrants this product to be free from defects in workmanship and material, under normal use and service conditions, for a period of two years on the Frame from the date of purchase. This warranty extends only to the original purchaser. IMPEX's obligation under this Warranty is limited to replacing or repairing, at IMPEX's option.

All returns must be pre-authorized by IMPEX. Pre-authorization may be obtained by calling IMPEX Customer Service Department at 1-800-999-8899. All freights for products return to IMPEX must be prepaid by the customer. This warranty does not extend to any product or damage to a product caused by or attributable to freight damage, abuse, misuse, improper or abnormal usage or repairs not provided by an IMPEX authorized service center or for products used for commercial or rental purposes. No other warranty beyond that specifically set forth above is authorized by IMPEX.

IMPEX is not responsible or liable for indirect, special or consequential damages arising out of or in connection with the use or performance of the product or other damages with respect to any economic loss, loss of property, loss of revenues or profits, loss of enjoyments or use, costs of removal, installation or other consequential damages or whatsoever natures. Some states do not allow the exclusion or limitation of incidental or consequential damages. Accordingly, the above limitation may not apply to you.

The warranty extended hereunder is in lieu of any and all other warranties and any implied warranties of merchantability or fitness for a particular purpose is limited in its scope and duration to the terms set forth herein. Some states do not allow limitations on how long an implied warranty lasts. Accordingly, the above limitation may not apply to you.

This warranty gives you specific legal right. You may also have other rights which vary from state to state. Register on-line www.impex-fitness.com

IMPEX[®] INC.
14777 Don Julian
City of Industry, CA 91746

ORDERING REPLACEMENT PARTS

Replacement parts can be ordered by calling our Customer Service Department toll-free at **1-800-999-8899** during our regular business hours: Monday through Friday, 9 am until 5 pm Pacific standard time.
info@impex-fitness.com

When ordering replacement parts, always give the following information.

1. Model
2. Description of Parts
3. Part Number
4. Date of Purchase

Free Manuals Download Website

<http://myh66.com>

<http://usermanuals.us>

<http://www.somanuals.com>

<http://www.4manuals.cc>

<http://www.manual-lib.com>

<http://www.404manual.com>

<http://www.luxmanual.com>

<http://aubethermostatmanual.com>

Golf course search by state

<http://golfingnear.com>

Email search by domain

<http://emailbydomain.com>

Auto manuals search

<http://auto.somanuals.com>

TV manuals search

<http://tv.somanuals.com>